



# Guide to Operations

115000-0



**IBM**·JX  
*personal computer*

## **LIMITED WARRANTY — IBM Personal Computer JX**

The International Business Machines Corporation warrants this IBM Personal Computer Product to be in good working order for a period of one year from the date of purchase from IBM or an authorized IBM Personal Computer dealer. Should this Product fail to be in good working order at any time during this one-year warranty period, IBM will, at its option, repair or replace this Product at no additional charge except as set forth below. Repair parts and replacement Products will be furnished on an exchange basis and will be either new or used. All replaced parts and Products become the property of IBM. This limited warranty does not include service to repair damage to the Product resulting from accident, disaster, transportation, misuse, abuse, or non-IBM alteration of or attachment to the Product.

Limited Warranty service may be obtained by delivering the Product during the one-year warranty period to an authorized IBM Personal Computer dealer providing proof of purchase date. If the Product is mailed or shipped, you are responsible to assume the risk of loss or damage in transit, to prepay mailing or shipping charges to the warranty service location and to use the original shipping container or equivalent. Contact an authorized IBM Personal Computer dealer or IBM for further information.

**THE FOREGOING WARRANTIES ARE IN LIEU OF ALL OTHER WARRANTIES, EXPRESS OR IMPLIED, INCLUDING, BUT NOT LIMITED TO, THE IMPLIED WARRANTIES OF MERCHANTABILITY AND FITNESS FOR A PARTICULAR PURPOSE.**

**IF THIS PRODUCT IS NOT IN GOOD WORKING ORDER, YOUR SOLE REMEDY SHALL BE REPAIR OR REPLACEMENT. IN NO EVENT WILL IBM BE LIABLE TO YOU FOR ANY DAMAGES, INCLUDING ANY LOST PROFITS, LOST SAVINGS OR OTHER INCIDENTAL OR CONSEQUENTIAL DAMAGES ARISING OUT OF THE USE OF OR INABILITY TO USE SUCH PRODUCT, EVEN IF IBM OR AN AUTHORIZED IBM PERSONAL COMPUTER DEALER HAS BEEN ADVISED OF THE POSSIBILITY OF SUCH DAMAGES, OR FOR ANY CLAIM BY ANY OTHER PARTY.**

**THIS LIMITED WARRANTY AND LIMITATION OF LIABILITY VOIDS AND SUPERSEDES ANY OTHER WRITTEN LIMITED WARRANTY BY INTERNATIONAL BUSINESS MACHINES CORPORATION WHICH IS INCLUDED WITH THE PRODUCT.**



# Guide to Operations

---

115000-0



**First Edition (August 1985)**

Changes are periodically made to the information herein; these changes will be incorporated in new editions of the publication.

It is possible that this material may contain references to, or information about, IBM products (machines and programs), programming, or services that are not announced in your country. Such references or information must not be construed to mean that IBM intends to announce such IBM products, programming, or services in your country.

© Copyright International Business Machines Corp. 1984, 1985

# Preface

This manual is written for those who are using a personal computer for the first time. The following are explained in easy-to-understand terms.

- **JX** Installation Procedures
- Keyboard Operations
- Starting a Program
- Characteristics of **JX**
- Problem Delermination Procedures

# How to Use this Manual

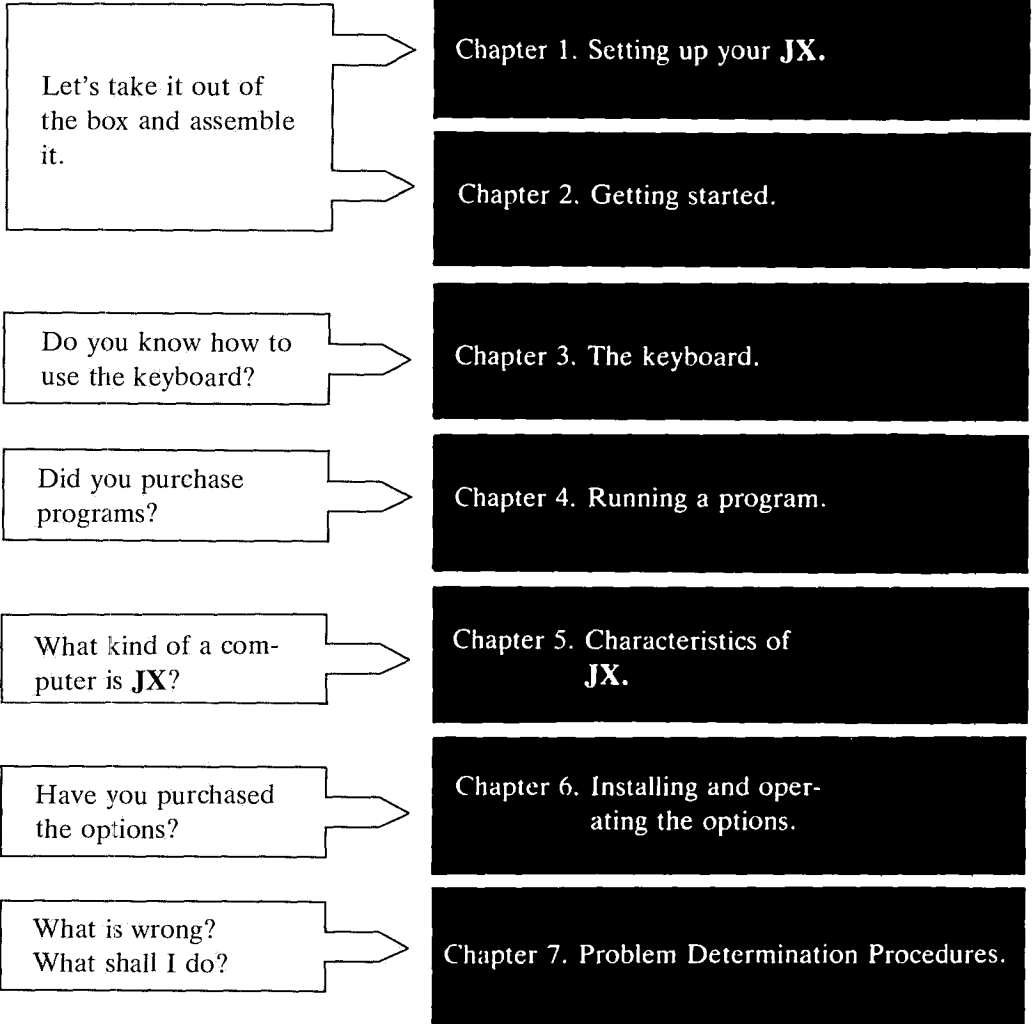

# Contents

## Well, let's start

<b>Chapter 1. Setting up Your JX</b> .....	1-1
Setup Instructions .....	1-3
Be Careful of the Following .....	1-9

## Turn ON the JX

<b>Chapter 2. Getting Started</b> .....	2-1
<b>Chapter 3. The Keyboard</b> .....	3-1
Introduction .....	3-4
Using the Keyboard .....	3-5
Centering the Information on the Screen .....	3-8
Keyboard Modes .....	3-11
System Reset .....	3-21
Additional Keyboard Features .....	3-22
<b>Chapter 4. Running a Program</b> .....	4-1
How to Start a Program .....	4-3
A Program on a Cartridge .....	4-4
What You Need .....	4-4
How to Insert and Remove a Cartridge .....	4-4
A Program on a Cassette Tape .....	4-5
What You Need .....	4-5
How to Start a Program in a Cassette Tape .....	4-5
A Program on a Diskette .....	4-8
What You Need .....	4-8
How to Start a Program on a Diskette .....	4-8
If the JX Power is ON .....	4-8
If the JX Power is OFF .....	4-9

## Let me Introduce You to the JX

<b>Chapter 5. Characteristics of JX</b> .....	5-1
System Unit .....	5-3
Keyboard .....	5-4
Display .....	5-5
<b>Chapter 6. Installing and Operating the Options</b> ..	6-1
System Extension .....	6-3
How to Connect a Joystick .....	6-4
Operation of Diskette Drive .....	6-5
Functions of 3.5 inch Diskette .....	6-5
Write-Protect Switch .....	6-6
Precautions in Use .....	6-6
Storing the 3.5-inch Diskette .....	6-6
What You Shouldn't Do .....	6-7

## What's the Matter?

<b>Chapter 7. Problem Determination Procedures</b> .....	7-1
--	-----



**Well, let's start!**





# Chapter 1. Setting up Your JX





# Setup Instructions

After completing the setup, insert this manual in Chapter 1, “Setting up your **JX**” in the *Guide to Operations*.

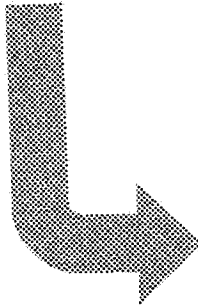

115001-0

## Let's get ready!

Three models are available.

Which is your model?

	Model 1	Model 2	Model 3
System Unit	○	○	○
3.5 inch Diskette Drive	—	1	2
Keyboard	△	△	△
64KB RAM Card	△	○	○
128KB RAM Card	△	△	○
Memory Capacity	64KB	128KB	256KB

○ : Standard

△ : Option

**Note:** all models can be purchased with either the compact or full keyboard.

1 Make sure that you have the following items.

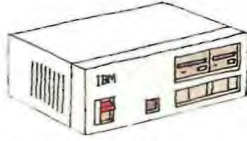

System Unit

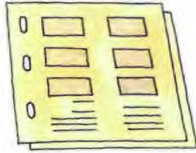

This Book



*Guide to Operations  
BASIC*



- 2** Open the battery compartment cover located on the bottom of the keyboard, by moving the cover in the direction indicated by the arrow.  
Insert the batteries in the direction indicated

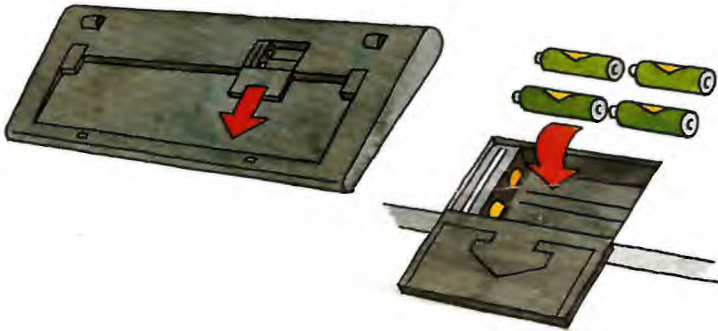

- 3** Make sure that the system unit power switch is OFF.

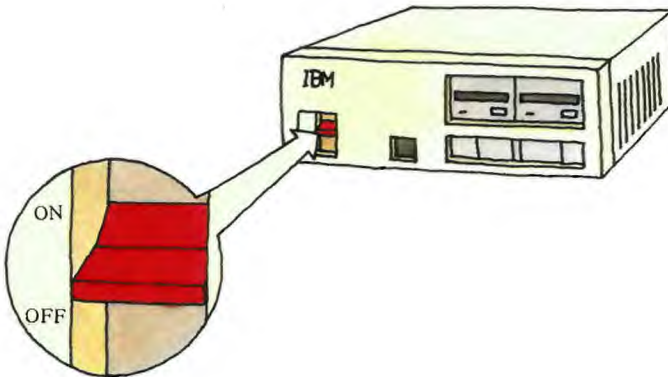



- 4** Connect the display to the system unit.

Connect the display according to the installation procedures in the *Display Operator's Guide*. Then, go to Step 5.

- 5** Connect the power cords to the system unit and the display.

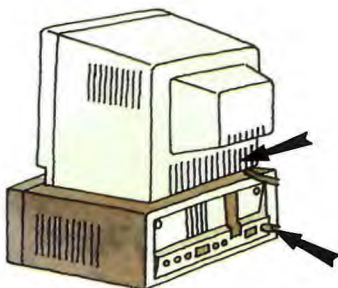

- 6** Insert the other end of the power cords into the receptacles.

Setup is now completed. Do not turn on the **JX** power switch yet.

Read, "Be Careful of the Following!", before proceeding to Chapter 2.



## Be Careful of the Following

When you use the **JX**, make sure:

1. That you use a 200~240V, 50/60Hz power outlet.

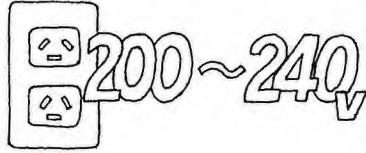

2. That you do not install the system upside down or on its side.



3. That you do not use it in a hot place.

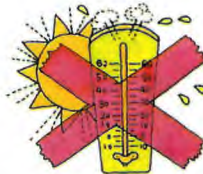

4. That you avoid high humidity and choose a well-ventilated area.



# Turn ON the JX

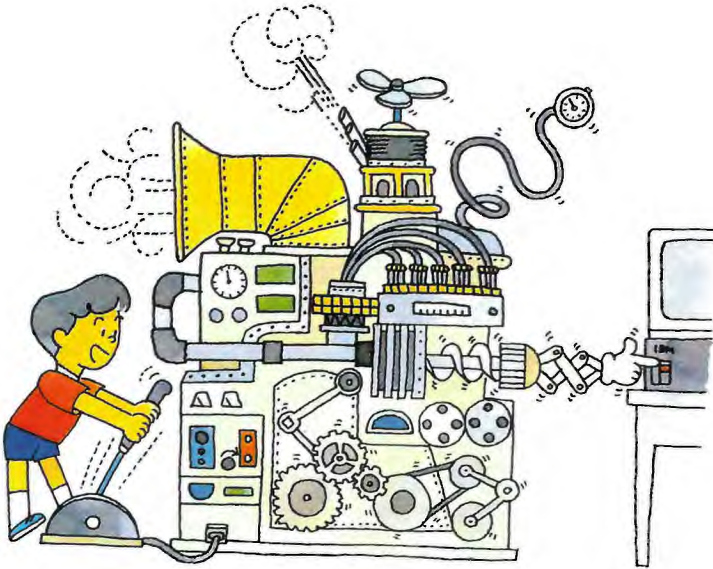

## Chapter 2. Getting Started



The distance between the keyboard and the system unit should be less than five meters when not using the keyboard cable. The **JX** may not operate if the infrared rays are obstructed.

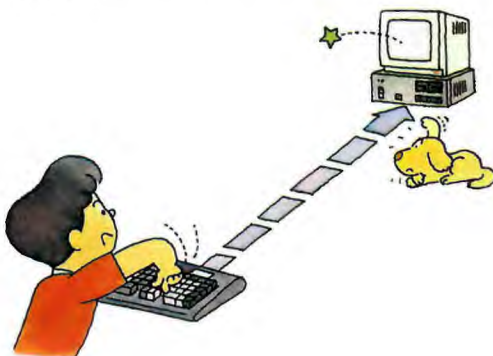

Well let's start the **JX**.

1. First, turn on the display power switch.

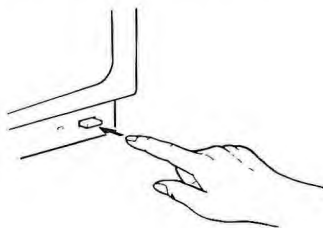

2. Then, turn on the system unit power switch.

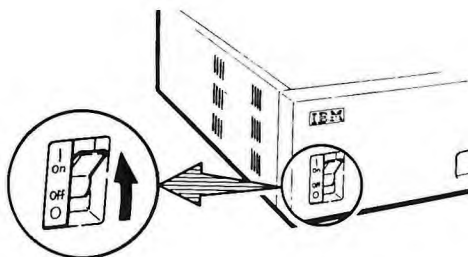

The following screen will appear.

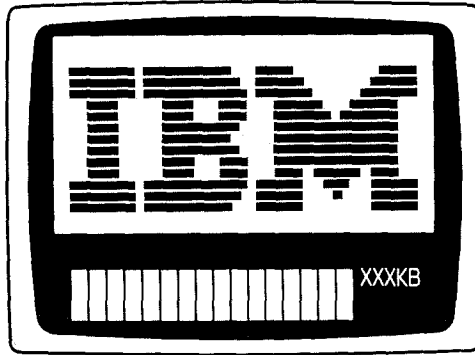

This screen is called the Test Screen. This screen is displayed for approximately 10 seconds, while the **JX** checks the system unit using the built-in self-diagnostics. If it finds nothing wrong, it makes a beep sound to let you know that everything is normal and the test screen changes to the initial BASIC screen.

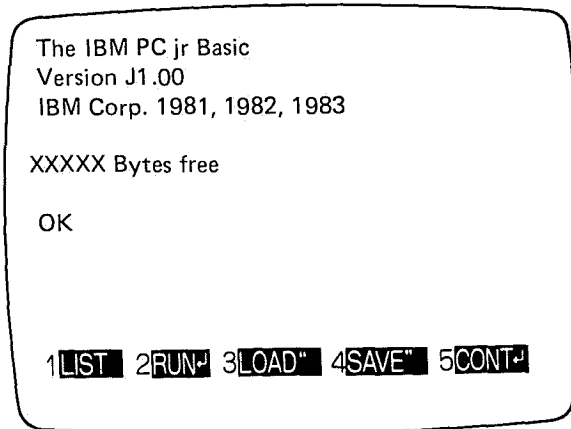

If the initial BASIC screen is not displayed, or if ERROR is displayed on the test screen, refer to Chapter 7, "Problem Determination Procedures".

3. Adjust the contrast and the brightness of the display to your liking.



4. If you want to tilt your keyboard, set up the legs on the bottom.

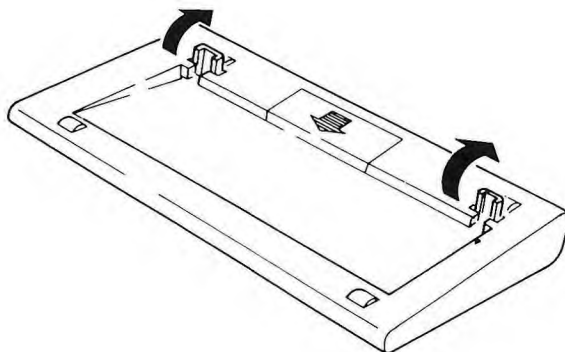



# Chapter 3. The Keyboard

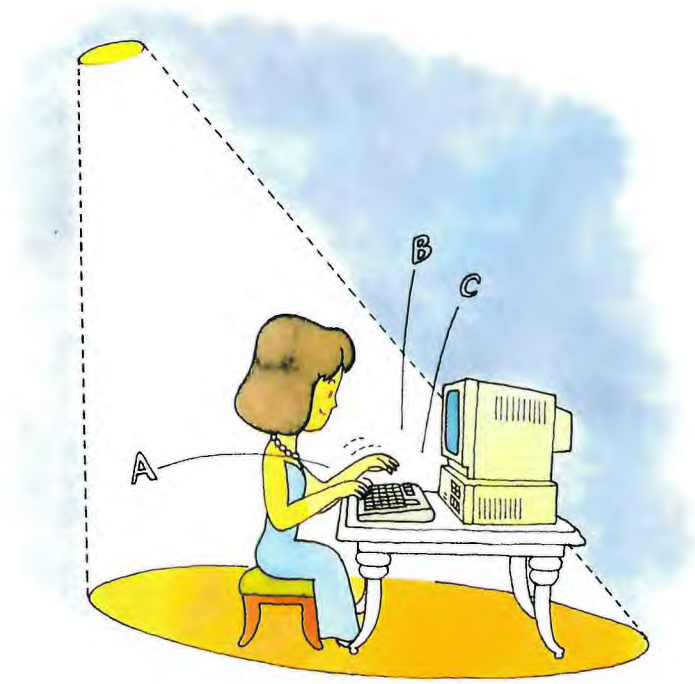



# Contents of Chapter 3

Introduction .....	3-4
Using the Keyboard .....	3-5
Centering the Information on the Screen .....	3-8
Keyboard Modes .....	3-11
System Reset .....	3-21
Additional Keyboard Features .....	3-22

## Introduction

This section shows you how to use your **JX** keyboard to operate your **JX**.

When you press a key, your keyboard sends a message to your **JX**. The program you use tells your **JX** what to do with that message. For instance, when you are playing a game, your “J” key may make a frog jump. But when you are using a program to write a letter to your friend, that same key simply types the letter “J”.

# Using the Keyboard

All keys on the keyboard except some control keys, are **typematic**. This means that each key repeats as long as you hold the key down.

You can select one of these keyboards:

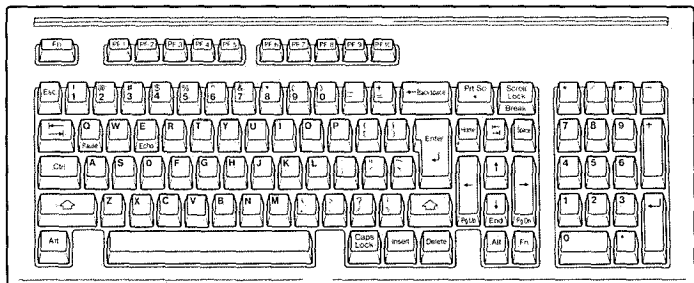
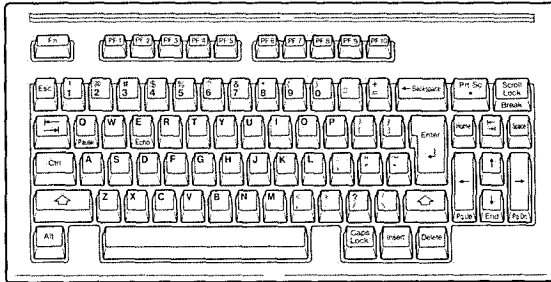

The positions of the keys are much like those of a standard typewriter. Most keys on the keyboard have an uppercase (capital) letter and a lowercase (small) letter.

Your keyboard has some extra keys that a typewriter doesn't have.

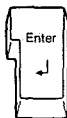

This is the Enter key.



This is the Print Screen (Prt Sc) Key. If you have a printer and you press and hold the Shift key and then press the Prt Sc key, the printer prints a copy of the information that is on the screen.

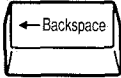

This is the Backspace key. When pressed, it erases the character to the left of the cursor and moves the cursor one position to the left.

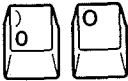

The zero “0” and the letter “O” are seen as two different characters by your **JX**. Do not use the zero when you want the letter “O” to appear.



The number one “1” and the letter “l” are also seen as two different characters by your **JX**. Do not use the number one (1) key when you want the letter “l” to appear.

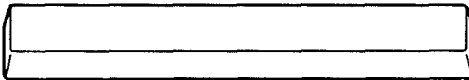

When pressed, the Space bar creates a blank on the screen and moves the cursor to the right.



This is the Escape (Esc) key.



This is the Tab key.

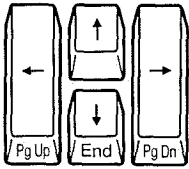

These are the cursor control keys.



In most programs, the Cursor Up key moves the cursor one line up.



In most programs, the Cursor Down key moves the cursor one line down.

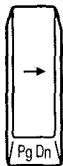

In most programs, the Cursor Right key moves the cursor one position to the right.

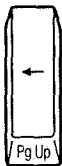

In most programs, the Cursor Left key moves the cursor one position to the left.

## Centering the Information on the Screen

If the writing on your screen is not centered, you can move it.

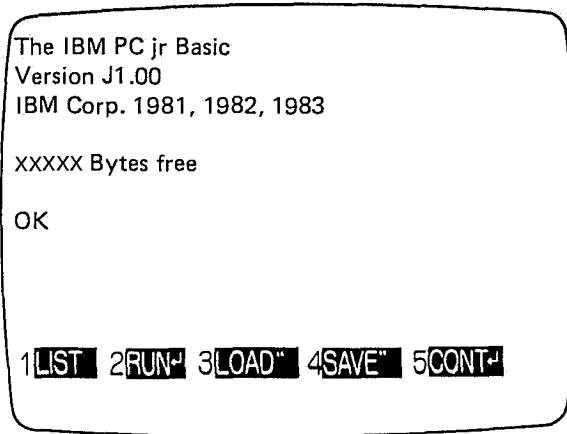

The writing on this screen needs to be moved to the right.



If the writing on your display's screen needs to be moved to the right, you can do this by pressing and holding

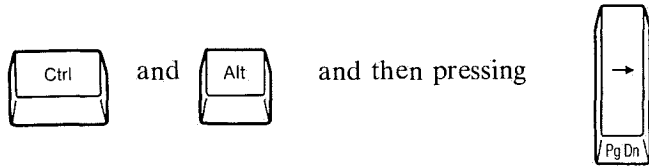

Each time you press the cursor right key while holding Ctrl and Alt, the writing on the screen moves one space to the right.

When the writing on the screen is centered, release all three keys.

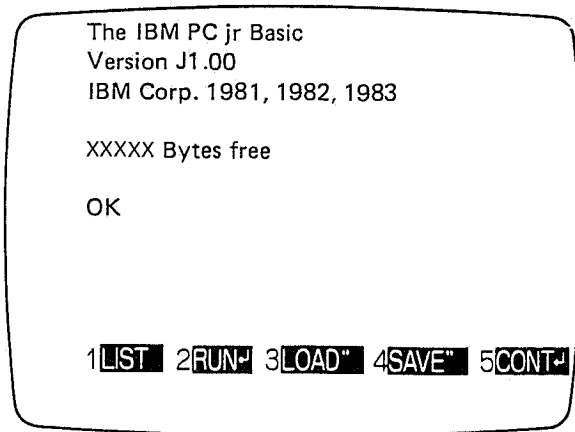

The writing on this screen needs to be moved to the left. You can do this by pressing and holding

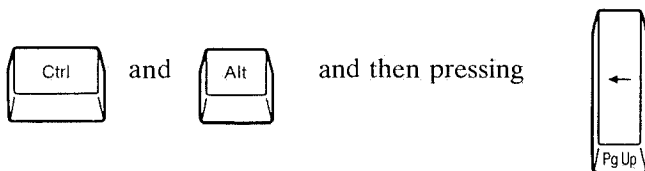

Each time you press the cursor left key while holding Ctrl and Alt, the writing on the screen moves one space to the left.

# Keyboard Modes

The keyboard can be placed into these modes:

- Regular mode
- Shift mode
- Caps Lock mode
- Alternate mode
- Control mode
- Function mode
- Numeric Lock mode

Let's see how the keys change for each of these modes.

## Regular Mode

When you turn your **JX** on, the keyboard is in the Regular mode. The keyboard remains in the Regular mode until you change the mode. Regular mode means that all alphabetic keys are in lowercase.

## Shift Mode

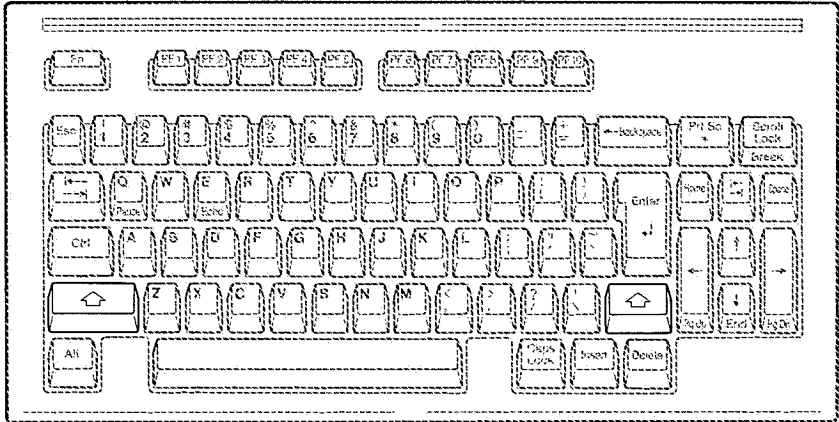

There are two shift keys on your keyboard. In the Shift mode, all keys type in uppercase.

To put the keyboard into the Shift mode, press and hold either Shift key and then press the key you have chosen to work with it.

The key you have chosen must be pressed while the Shift key is held down.

Shift mode ends and Regular mode returns when you remove your finger from the Shift key.

When you first turn your **JX** power on, the IBM Personal Computer BASIC Message Screen appears. Using this screen and the following instructions, try your keyboard.

Remember, when you first turn your **JX** power on, your keyboard is in lowercase.

The lower character on the key top shows the lowercase numbers and symbols.

The upper character on the key top shows the uppercase symbols.

For instance, look at the key in the top row marked



Press it.

The number 4 appears on the screen.

Now press and hold down the Shift key.

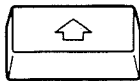

Then press



A \$ now appears.

## Caps Lock Mode

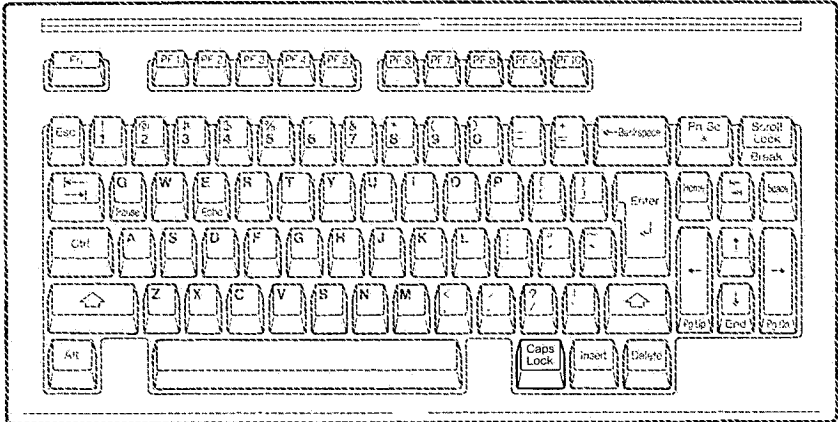

To put the keyboard into the Caps Lock mode, press the Caps Lock key once and release it.

In the Caps Lock mode, the letters A through Z appear in uppercase.

The keyboard stays in the Caps Lock mode until you press Caps Lock again.

If you want to type a lowercase letter or a symbol, while the keyboard is in the Caps Lock mode, you have to press the Shift key.

You can type lowercase characters while in the Caps Lock mode by pressing and holding the Shift key and then pressing the key for the character you have chosen to appear in lowercase.

To cancel the Caps Lock mode, press Caps Lock again and release it. Your keyboard then returns to the Regular mode.

## Alternate Mode

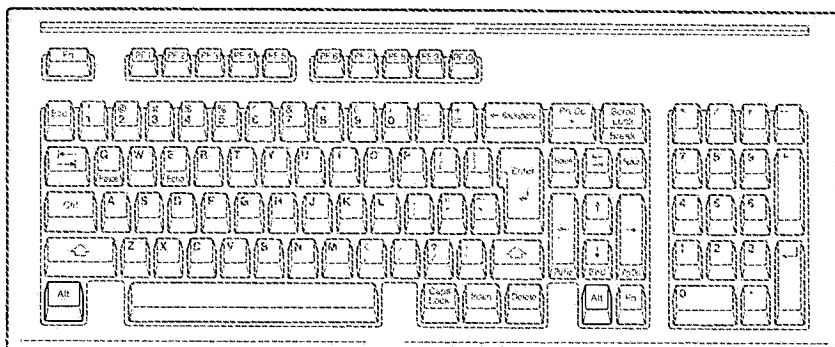

Some keys will display different symbols when used in combination with the Alternate (Alt) key (Alternate mode), depending on functions that are determined by the program you use.

The key you have chosen to use with Alt must be pressed while the Alt key is held down.

Alternate mode ends when you stop pressing the Alt key. Your keyboard then returns to the Regular mode.



## Control Mode

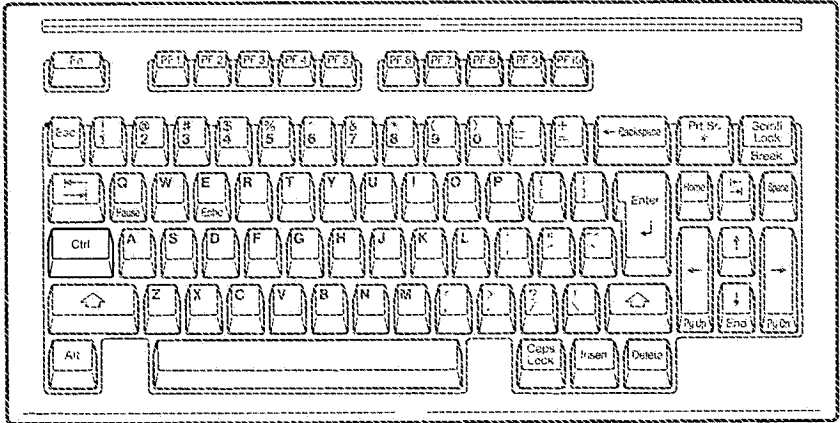

The Control key (Ctrl) on the left side of your keyboard performs functions that are determined by the program you use. To put the keyboard in Control Mode, press and hold the Control key and then press the key you have chosen to work with it. Control Mode ends when you stop pressing the Ctrl key.

# Function Mode

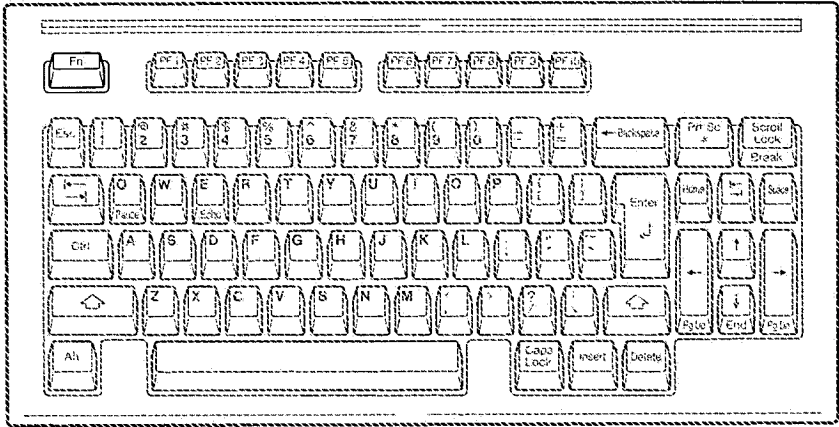

To use the Function mode, first press and release the Fn key. Then press the key you desire. After you press the key, the Function mode is canceled.

If you have more than one function to perform, you may press and hold the Fn key while pressing the other keys.

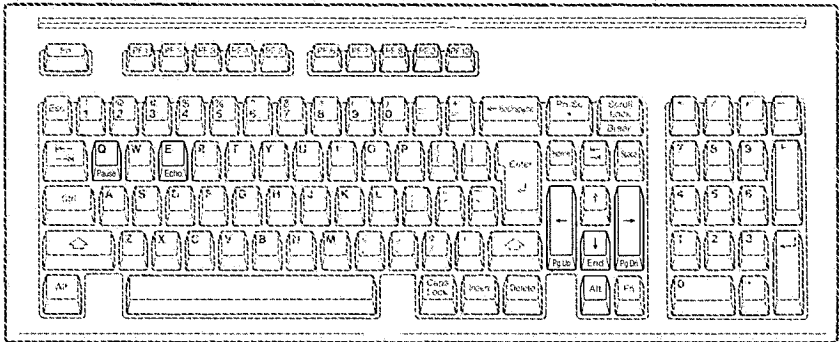





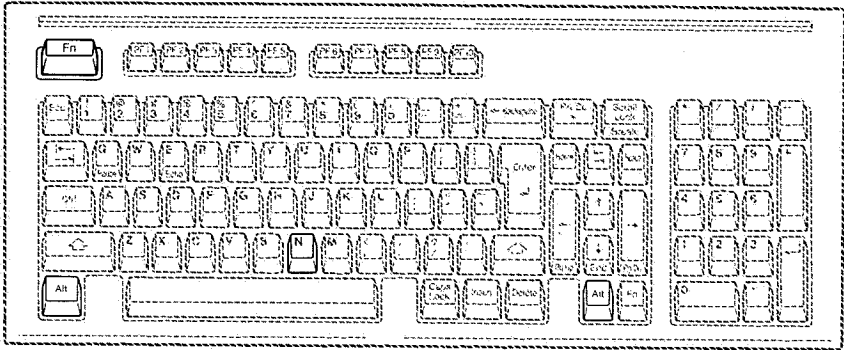

If you press the Fn key by accident, press the Shift key to cancel the Function mode.

You can lock your keyboard in the Function mode by pressing and holding the Shift and Fn keys and then pressing the Esc key. When locked in the Function mode, all keys perform their functions without needing the Fn key pressed first. To unlock the Function mode, press and hold Shift and Fn and then press Esc.

## Numeric Lock Mode



To put the keyboard into Numeric Lock mode, press and hold  then press  and .

The keyboard stays in Numeric Lock mode until  --  --  is pressed again.

This mode is not required to enter numbers on the **JX** keyboard. Both the numeric keys on the top row of the keyboard, and the numeric keys on the numeric keypad can be used to enter numbers while in Regular mode.

Numeric Lock mode should be used when you want to enter ASCII codes. When in Numeric Lock mode, press  followed by three numeric characters to enter each ASCII code. The numeric keys on the top row must be used to enter the numeric characters. The numeric keys on the numeric keypad can not be used.

# System Reset

While using your **JX** there will be many times that you will want to perform a system reset or reset, (reset and system reset mean the same thing).

There are two ways to reset your **JX** while you are using it. The first way is to turn your **JX** power off, wait five seconds, then turn power on. The second way is to use your keyboard as follows:

Press and hold

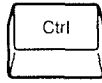

and



Then press



Release all three keys.

Some things that you might use a reset for are:







- Starting a program over again.
- Loading a program from a diskette.

# Additional Keyboard Features

## Keyboard Legs

Your **JX** keyboard is equipped with adjustable legs. You can find the position that is comfortable to you, by typing on the keyboard with the legs up and then down.

## Keyboard Clicker

Your **JX** has a feature called the Keyboard Clicker. When this feature is turned on, every time you press a key you will hear a clicking sound. To turn the Keyboard Clicker on, press and hold  and , and then press . To turn the clicker off, press and hold  and  and then press .

---

# Keyboard Cable Option Guide

---

Connect the Keyboard cable to the back of the system unit.

Position the keyboard cable as indicated in the drawing.

Connect the other end of the keyboard cable to the back of the keyboard.

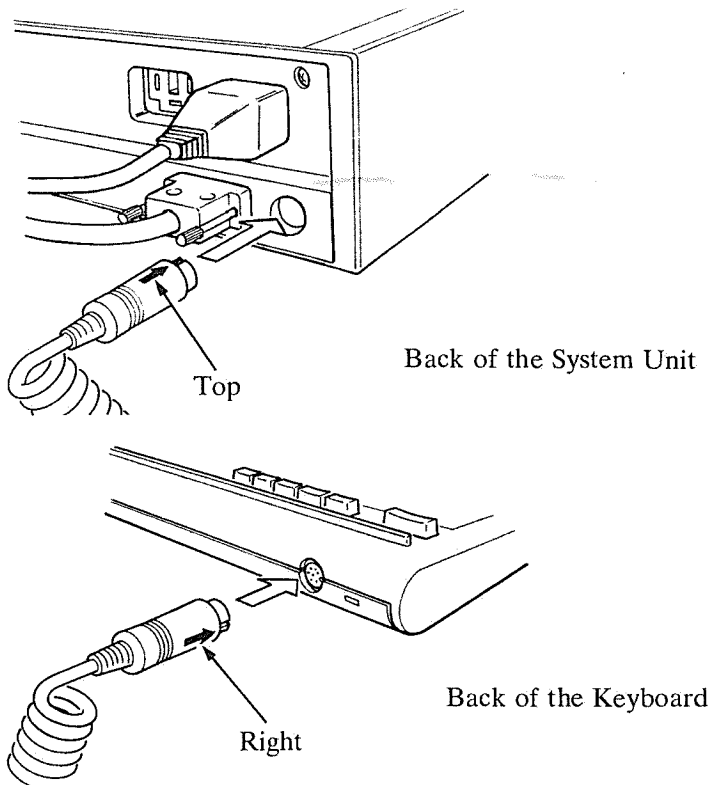



First Edition (August 1985)

© Copyright International Business Machines Corporation 1984, 1985

Keyboard Cable Option Guide 115014-0 Printed in Japan



# Chapter 4. Running a Program

You have mastered the keyboard operations, so now you can communicate with the computer.

This chapter explains how to start various programs.

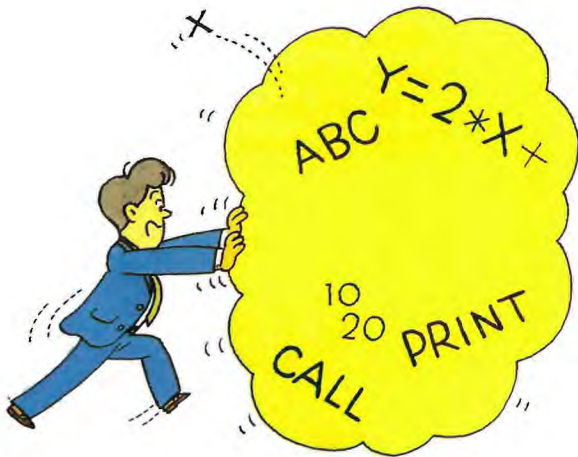

# Contents of Chapter 4

How to Start a Program .....	4-3
A Program on a Cartridge .....	4-4
What You Need .....	4-4
How to Insert or Remove a Cartridge .....	4-4
A Program on a Cassette Tape .....	4-5
What You Need .....	4-5
How to Start a Program on a Cassette Tape .....	4-5
A Program on a Diskette .....	4-8
What You Need .....	4-8
How to Start a Program on a Diskette .....	4-8
If the <b>JX</b> Power is ON .....	4-8
If the <b>JX</b> Power is OFF .....	4-9

# How to Start a Program

Most programs are sold on cartridges, cassette tapes, or diskettes.

Some **JX** programs require options. Ask the dealer when buying a program if any options are required.

The following section describes:

1. How to start a program on a cartridge.
2. How to start a program on a cassette tape.
3. How to start a program on a diskette.

Refer to the users manual which comes with your program for instructions on starting it.



# A Program on a Cartridge

## What You Need

- A cartridge containing a program

## How to Insert and Remove a Cartridge.

- A cartridge can be inserted and removed at anytime. When a cartridge is inserted or removed, **JX** will be reset automatically.
- **JX** has two cartridge slots as illustrated.

Insert a cartridge in either of the slots, making sure that the label on the cartridge faces up. Push in the cartridge until you hear a clicking sound.

- The cartridge program will start automatically.

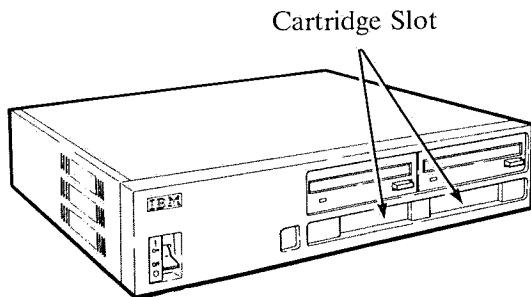

# A Program on a Cassette Tape

## What You Need

- A cassette tape containing a program.
- A cable (option) for the cassette tape recorder.
- A cassette tape recorder or a data recorder.

**Note:** We recommend the use of a cassette tape recorder that meets the following conditions:

- a. It can be started and stopped remotely by the computer.
- b. It has a tape counter.

## How to Start a Program in a Cassette Tape

1. Insert one end of the Cassette-tape cable into the connector which is labelled “Cassette”.

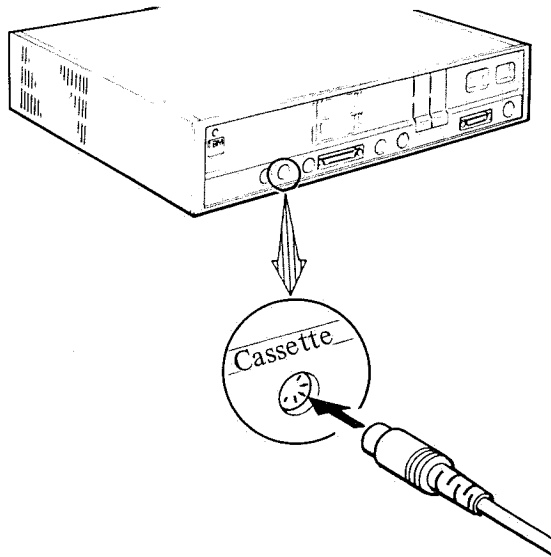

2. Insert the other end of the cassette-tape cable into the cassette tape recorder as shown below.

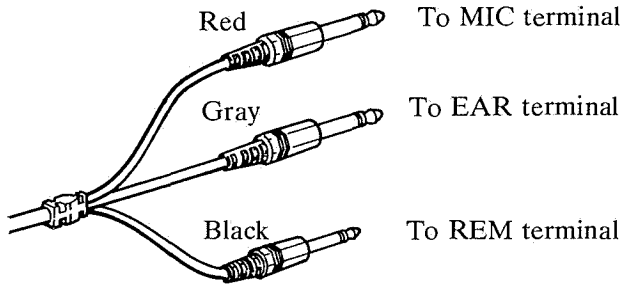

3. Insert the cassette tape containing the program in the cassette tape recorder. Adjust the volume control to a relatively high position in order to prevent sound distortion.

**Note:** Make sure that the cassette tape has been re-wound.

4. Make sure that **OK** is displayed on the screen.

If the cassette recorder has a remote terminal feature, go to step 6.

5. Press the **PLAY ▶** Button.

If a remote terminal is connected, the computer will start or stop the cassette tape recorder. It cannot be operated by pressing the **PLAY ▶** Button.

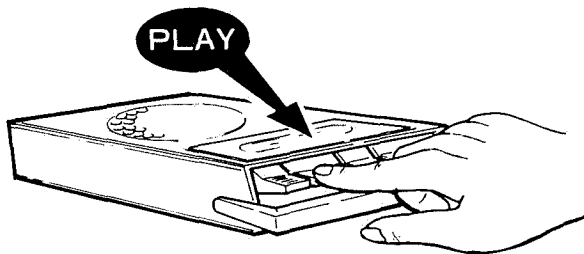

6. Type the following:

### **RUN "CAS1: Program Name"**

The program name is written on the cassette tape or in the program user's manual.

Example: To start a program with the name "DEMO", type the following.

### **RUN "CAS1: DEMO"**

7. Press  key

When a remote control feature is not connected, press PLAY ►.

Soon, the program will begin to run.

To terminate the program, press and hold  and , and then press .

The contents of each program is described in detail in the user's manual.



# A Program on a Diskette

## What You Need

- A diskette containing a program

## How to Start a Program on a Diskette.

**Note:** When the red light on the front of the diskette drive is ON, **JX** is reading data from the diskette or writing data onto it. **DO NOT** remove the diskette from the diskette drive at this time.

### If the JX Power is ON:

1. Insert the diskette into the diskette drive until it clicks.

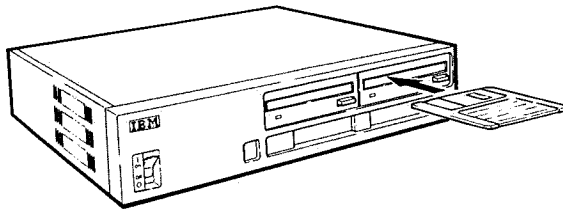

2. Press and hold  and , and then press .



**If the JX Power is OFF:**

1. Insert the diskette into the diskette drive until it clicks.

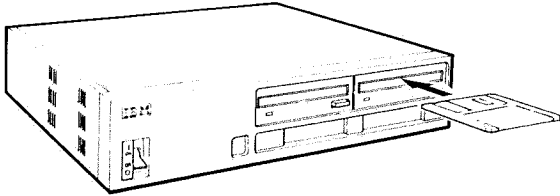

2. Turn the **JX** power ON.

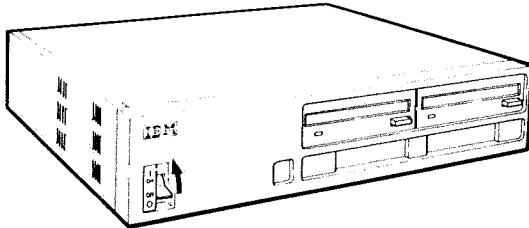

# Let me Introduce you to JX

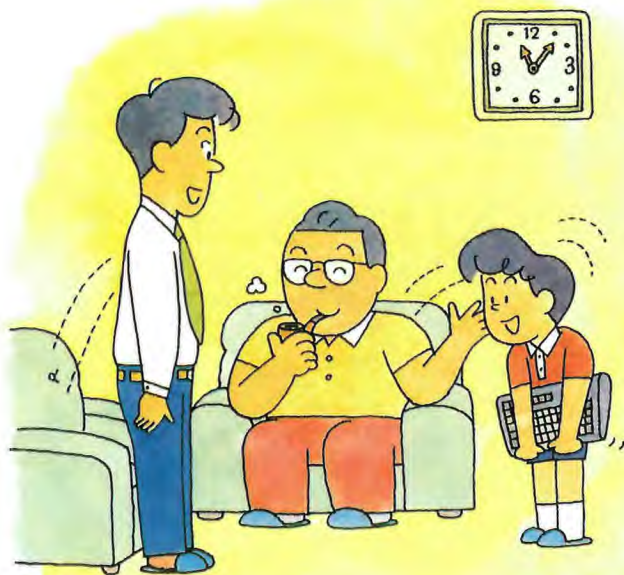

# Chapter 5. Characteristics of JX



# Contents of Chapter 5

System Unit .....	5-3
Keyboard .....	5-4
Display .....	5-5

# System Unit

The system unit has a 16-bit microprocessor. The memory capacity can be expanded from 64 KB to 512 KB.

It has a large variety of standard functions, such as an eight-octave, triple-chord sound generator.

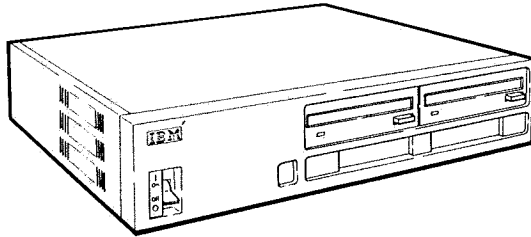

CPU: 8088 (4.77 MHz)

System ROM: 96KB

Standard memory capacity: 64KB (Max. 512 KB)

Keyboard Interface

Display Interface

Joystick Interface

Audio Interface

Parallel Interface

Cassette Interface

Light-pen Interface

# Keyboard

The **JX** supports two keyboards: a compact keyboard which has 79 keys and a full keyboard which has 98 keys, the keyboard can be used either with or without a keyboard cable.

## Compact Keyboard

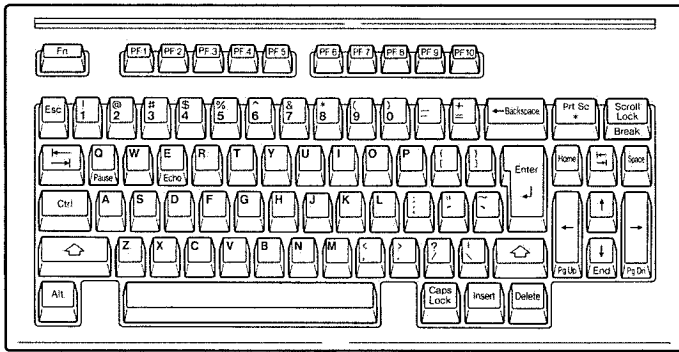

## Full keyboard

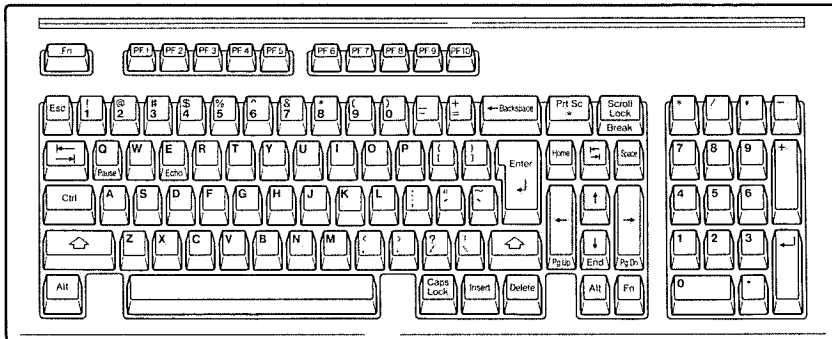

# Display

The IBM 5515 display supports 16 colors. The display is of medium resolution and has a speaker for audio output.

The resolution specifications of the display are given below.

<b>Re- solu- tion</b>	<b>Text Mode</b>	<b>Normal-width Character</b>	80 x 25
		<b>Double-width Character</b>	40 x 25
	<b>Graphic Mode</b>		640 x 200 320 x 200 160 x 200

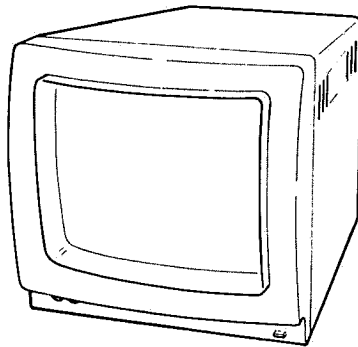





---

# Display Operator's Guide

---

This manual describes the procedures for installing and operating the display.

This manual consists of the following.

Parts List .....	1
Installation Instructions .....	2
Testing after Installation .....	5
Operating Procedures .....	9
Precautions .....	11
Specifications of the Display .....	12

After completing the installation, insert this manual in the Chapter 6, "Installing and Operating the Options," of the *Guide to Operations*.

**First Edition** (August 1985)

Changes are periodically made to the information herein; these changes will be incorporated in new editions of the publication.

It is possible that this material may contain references to, or information about, IBM products (machines and programs), programming, or services that are not announced in your country.

Such references or information must not be construed to mean that IBM intends to announce such IBM products, programming, or services in your country.

# Parts List

---

- IBM5515 12-inch Color Display.

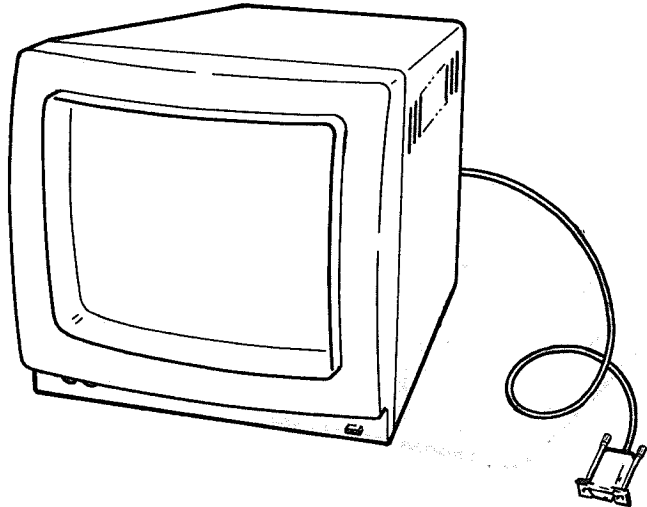

**If the display was damaged during shipment, please contact your dealer.**

# Installation Instructions

---

- 1 Before connecting the display to the system unit, turn the system unit power off. Then, turn the other device power off and remove the power cord from the power outlet.

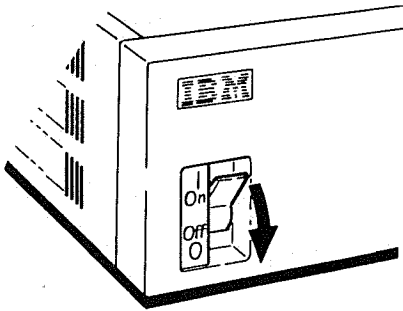

- 2 After connecting the display cable connector to the socket labeled “Display” on the back of the system unit, tighten the screws on both sides of the connector.

**Note:** The connector cannot be inserted unless it is positioned correctly.

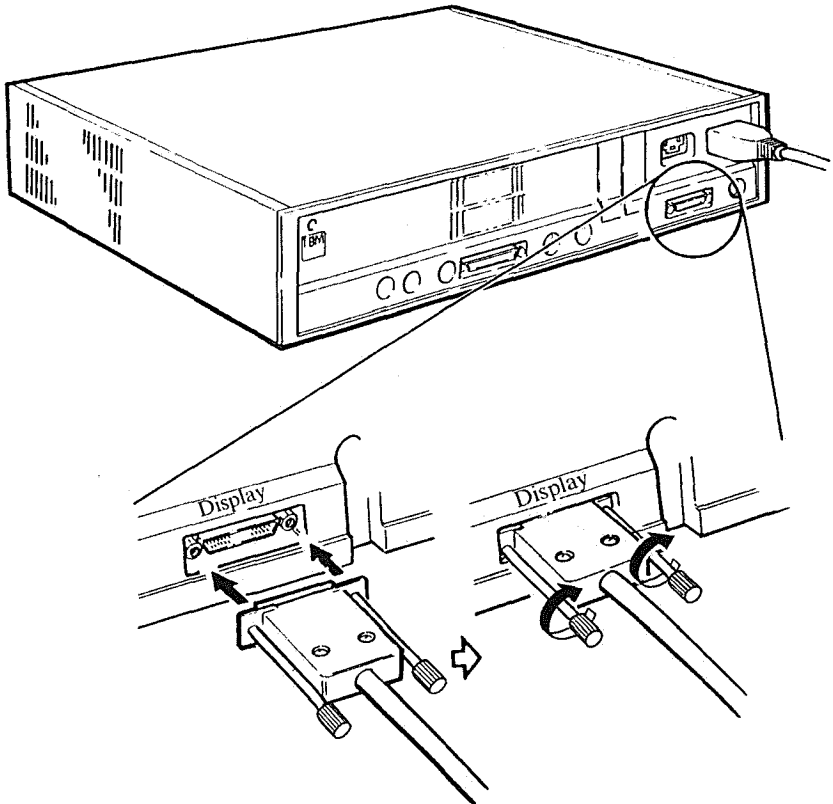

- 3 Insert one end of the display power cord into the connector on the back of the display, and the other end into a power outlet.

Your display is now installed.

### Power Switch and Power Light

Press the power switch to turn the power ON; press it again to turn the power OFF. The power light remains ON while the switch is ON.

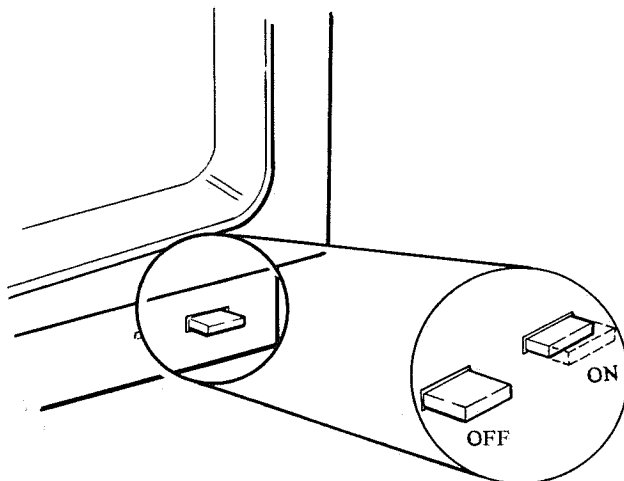

## Testing after Installation

Generally, after installing parts, they must be tested to ensure that they have been installed correctly.

**JX** executes a self-diagnostic test automatically when the system unit is turned ON. Therefore, no special operation is necessary for post-installation testing.

- 1 Take out any cartridges and diskettes inserted.

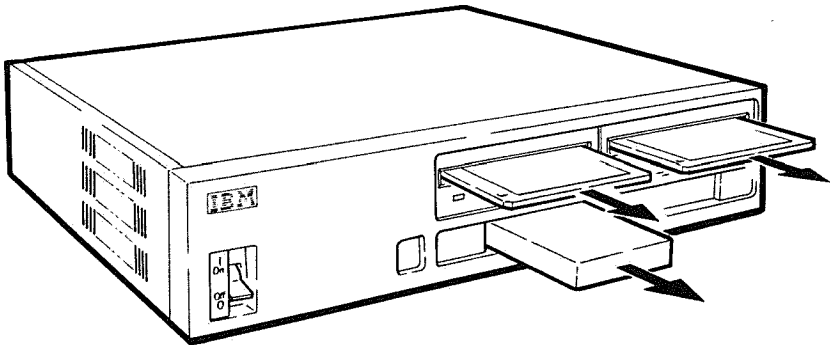

- 2 Turn the display power on.  
Then turn the system unit power on.

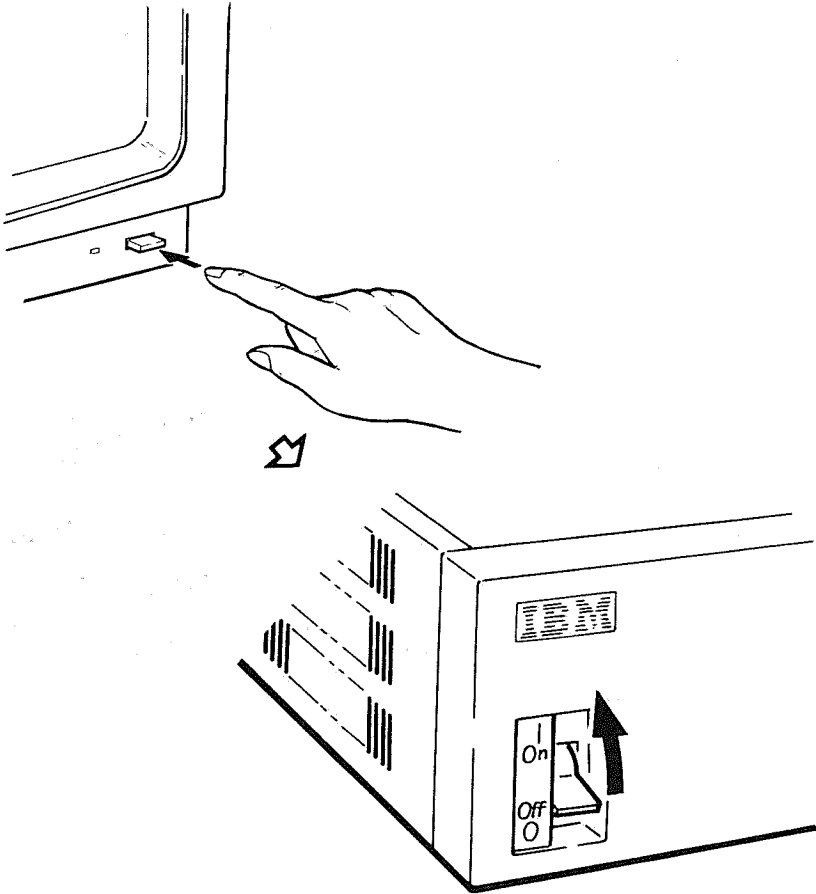

The self-diagnostic test starts automatically. When the display is installed correctly, the following operations will take place.



The test screen appears.

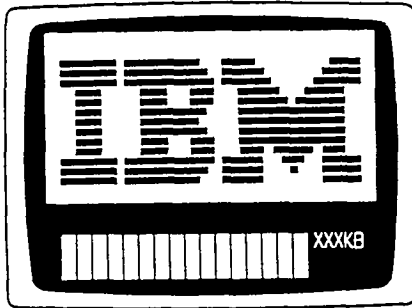

A single beep sounds.

"Beep"

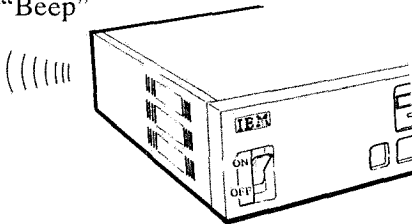

The BASIC initial screen is displayed.

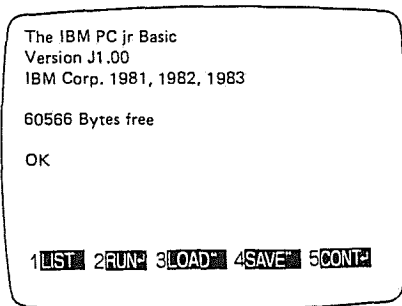

If the following error screen is displayed, refer to “Chapter 7, Problem Determination Procedures” in the *Guide to Operations*.

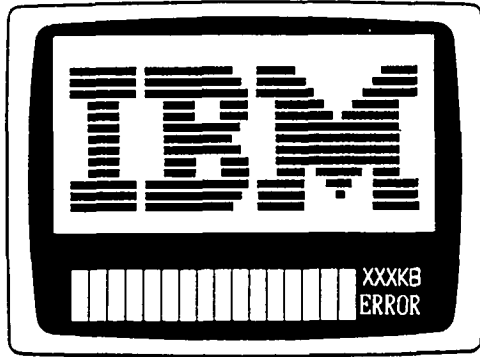

Adjust the brightness and the volume on the display according to the operating instructions on the following page.

# Operating Procedure

---

Name of Knob	Purpose	Operation	Remark
Brightness	Adjust the brightness of the characters symbols, and graphics displayed on the screen.	Turn the knob clockwise to obtain a brighter screen. Turn it counterclockwise to obtain a darker screen. Adjust the screen to the desired brightness.	Note 1
Volume	Adjust the volume of the sound from the built-in display speaker.	Turn the knob clockwise to increase the volume. Turn it counterclockwise to decrease the volume.	Note 2

## Notes:

1. If the screen is too bright, the characters may look blurred. In this case, darken the screen slightly.
2. If the sound is too loud, it may become distorted.

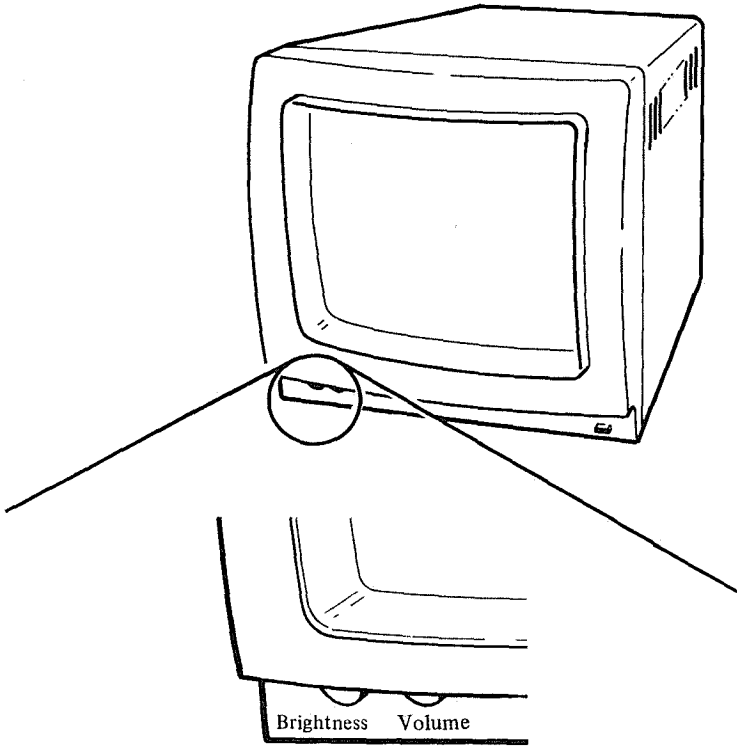

## Precautions

---

1. To turn the power switch on after turning it off, wait at least three to four seconds before turning it ON again.
2. If the surface of the display screen is dirty, clean it with a soft cloth. If required, moisten the cloth with water or a mild detergent. Never use organic solvents, such as alcohol or benzene.
3. Never put anything on top of the display.

# Specifications of the Display

---

Model		2E1	HE1
Resolution (dots)		640 × 200	
Dot pitch (mm)		0.45	
Input terminal		15 pins (D-SUB male)	
Maximum Display Capacity	Alphanumerics	80 characters × 25 lines	
Number of Displayable Colors		16 colors	
Operating Environment	Temperature	5 ~ 35°C	
	Humidity	20 ~ 80%	
Power		230-240V (50Hz)	200-220V (50Hz)
Rated Power Consumption		50W	
Dimensions (mm)		312 × 322 × 377 (H) (W) (D)	
Weight		Appr. 9.5kg	





Display Operator's Guide 115002-0 Printed in Japan



# Chapter 6. Installing and Operating the Options



## Contents of Chapter 6

System Extension .....	6-3
How to Connect a Joystick .....	6-4
Operation of Diskette Drive .....	6-5
3.5-inch Diskette .....	6-5
Write-Protect Switch .....	6-6
Precautions in Use .....	6-6
Storing the 3.5-inch Diskette .....	6-6
What You Shouldn't Do .....	6-7

## **System Extension**

If you have bought options, follow the instructions in manual of each option to install options.

Insert the each option manual at the end of this chapter.

# How to Connect a Joystick

- 1 Turn off the system unit power.

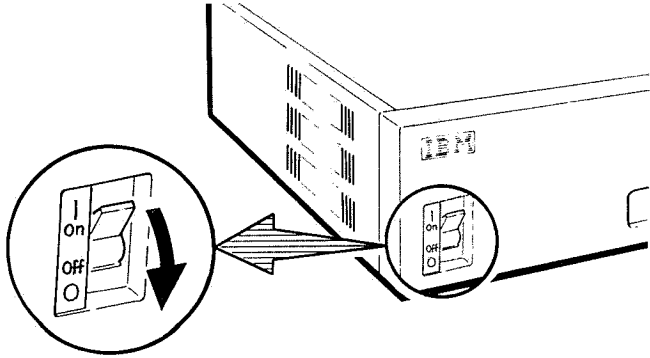

- 2 Connect the joystick cable to one of the joystick connectors on the back of the system unit.

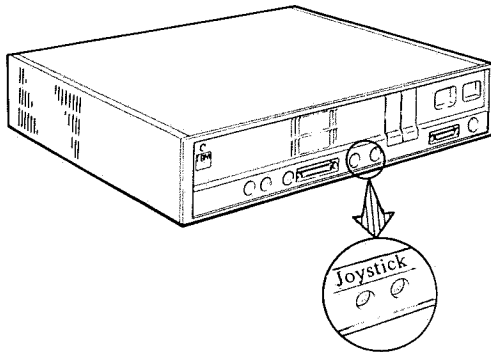

The joystick has been connected.

# Operation of Diskette Drive

Both the 3.5-inch and 5.25-inch diskettes can be used on **JX**.

To use a 5.25-inch diskette, the expansion unit and the 5.25-inch diskette drive are necessary.

The operations of a 5.25-inch diskette are described in “5.25-inch Diskette Drive Option Guide.”

## 3.5-inch Diskette

**Note:** Before using a diskette, be sure to read and observe the instructions given below.

A diskette is a thin disk (magnetic storage medium) in a protection jacket. It stores data and programs.

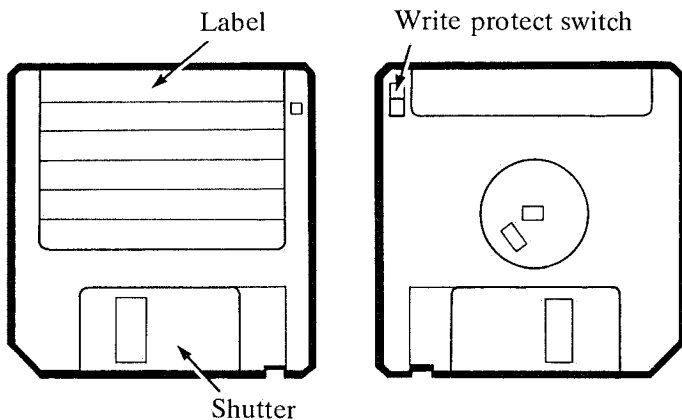

## Write-Protect Switch

This switch enables or disables writing on a diskette depending on its position.

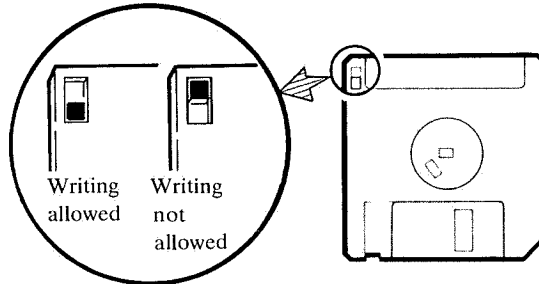

## Precautions in Use

The diskettes must be handled carefully because they can be easily damaged. Careless handling may lead to loss of information that is recorded on the diskette or prevent the recording of new information.

While the diskette drive light is ON, do not remove the diskette or turn the power switch on the system unit off. The file being used may be destroyed.

## Storing the 3.5-inch Diskette

If diskettes are stored horizontally, do not stack more than 11 diskettes in one container. If diskettes are stored vertically, support them to prevent them from slanting or bending. Protect the diskettes from dust and lint.

## What You Should Not Do

Do not place a magnetized object near a diskette. If a diskette is placed in a magnetic field, the data may be lost. A magnetic field can exist near a fluorescent lamp, a desk calculator, a tape recorder, a speaker, a driver, a copy machine, a telephone, etc.

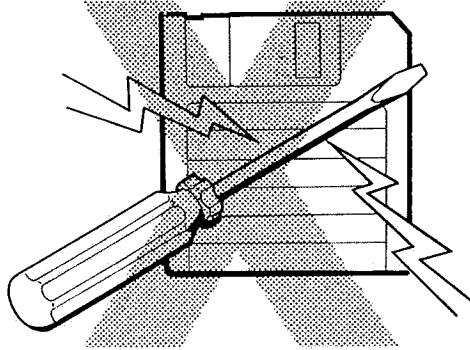

Write on the label before sticking it on the diskette. If the label is already on the diskette, use only a felt tip marker.

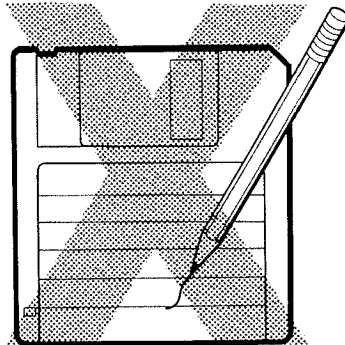

Do not erase on the label of a diskette. Do not use an eraser on or near the diskette. It's residue may damage the diskette.

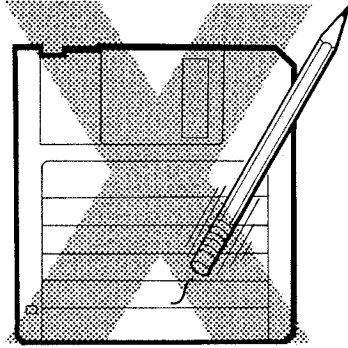

Do not open the diskette shutter and touch the recording surface directly with your hand. Perspiration can damage the diskette.

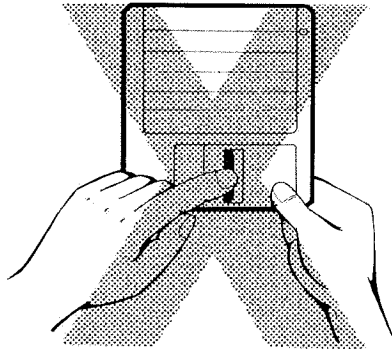



Do not place anything heavy on the diskette.  
It can damage the diskette surface.

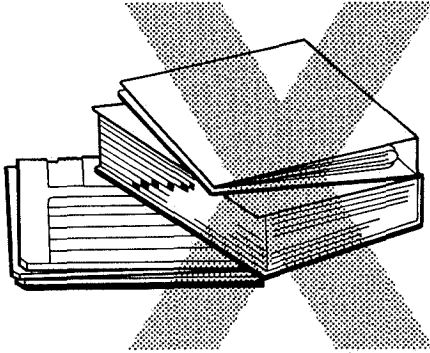

Do not use clips or rubber bands on a diskette.

Do not bend a diskette.

Place a diskette on a flat surface and make sure that it does not bend.

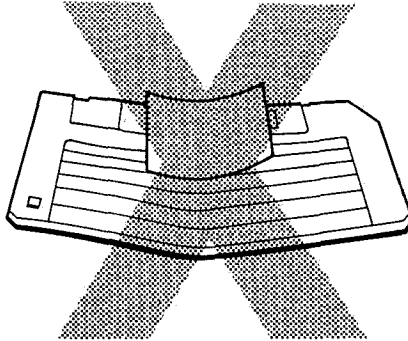

Do not try to rub the diskette surface to clean it. Do not use a dirty diskette.

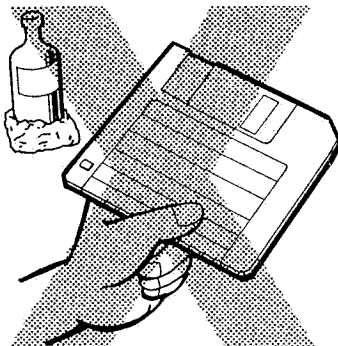

Do not put a diskette near an ash tray or near foods; they can damage the diskette.

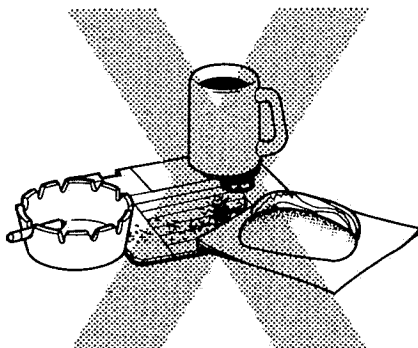

Do not put a diskette in a hot place over 51°C. Do not expose it to direct sunlight.

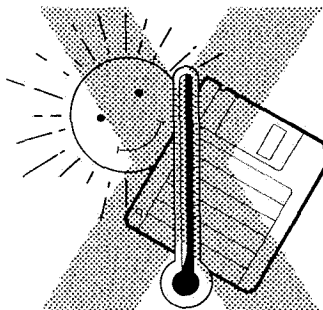

---

---

Warning

---

---

If a diskette has been left in a temperature outside the range of 10°C~51°C, leave the diskette at room temperature for about 5 minutes before inserting it into the diskette drive.

---

---



# What's the Matter?





---

# RS-232C Card Option Guide

---

This manual explains the procedures for installing the RS-232C card and the method for diagnosing whether it is functioning correctly.

The JX System has been designed so that the RS-232C card can be easily installed. You need no special knowledge, you need only to follow the instructions in this manual.

This manual consists of the following:

Parts List .....	1
Tools Required .....	2
Installation Instructions .....	3
Testing after Installation .....	10
Appendix .....	16

After completing the installation, insert this manual in Chapter 6, "Installing and Operating the Options" in the *Guide to Operations*.

**First Edition** (August 1985)

Changes are periodically made to the information herein; these changes will be incorporated in new editions of the publication.

It is possible that this material may contain references to, or information about, IBM products (machines and programs), programming, or services that are not announced in your country.

Such references or information must not be construed to mean that IBM intends to announce such IBM products, programming, or services in your country.



# Parts List

---

Before starting to install the RS-232C card, make sure that you have all the following parts.

RS-232C Card

Screw

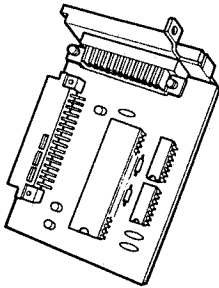

**If any of the parts are missing or have been damaged during shipment, please contact your dealer.**

For connection to a communication line, the following parts are available.

Wrap Connector

RS-232C Cable

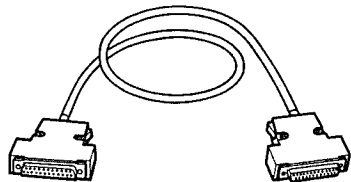
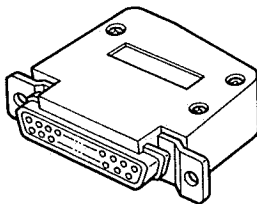

## **Tools Required**

---

- Medium-size Phillips screwdriver

# Installation Procedure

---

- 1 Turn the system unit power off and remove the power plug from the power outlet.

Turn the other peripheral devices power off (display, printer, etc.) and remove their power plugs from the power outlets.

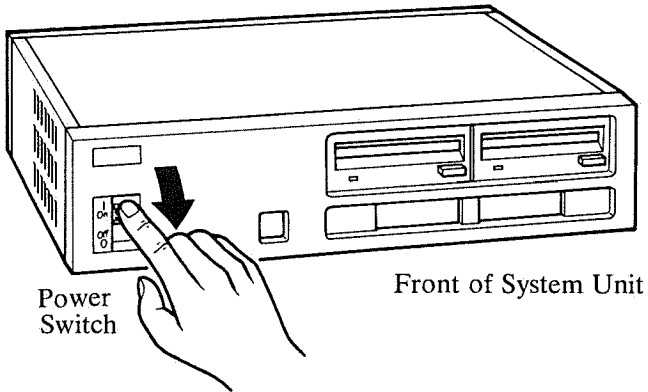

**2** Remove the top cover from the top unit (system unit or expansion unit).

- (1) Loosen the two screws on the back of the unit by turning them to the left with a screw driver. The screws cannot be removed, but they must be loosened completely.

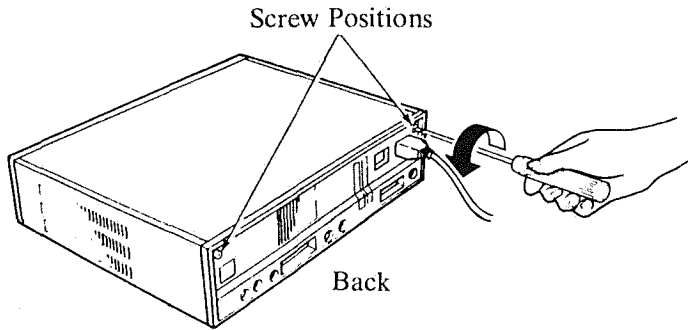

- (2) Insert a coin into the groove on the back of the cover and lift it using a coin as a lever. Remove it by pulling it towards the back.

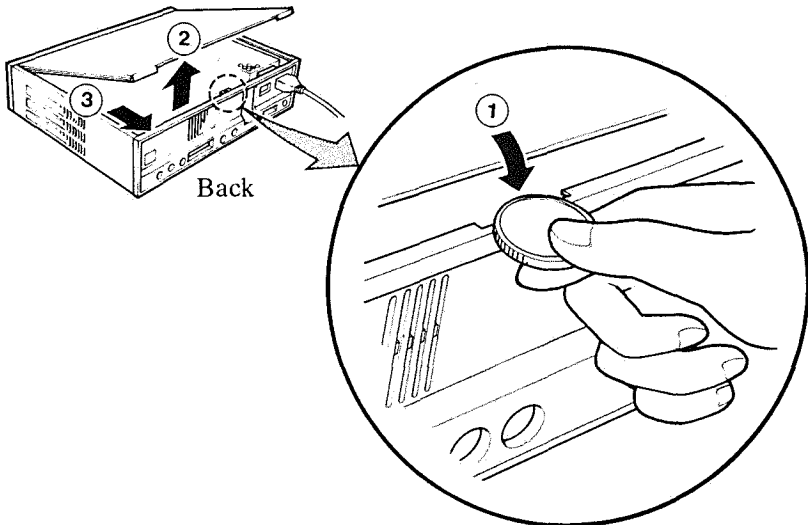

**3** If the expansion unit is installed, disconnect it.

If the expansion unit has an expansion board, disconnect it by referring to the *Expansion Board Option Guide* before performing the following procedures.

- (1) Remove the expansion unit power plug from the system unit. Then, loosen the two screws on the back by turning them to the left with a screw driver. The screws cannot be removed, but they must be loosened completely.

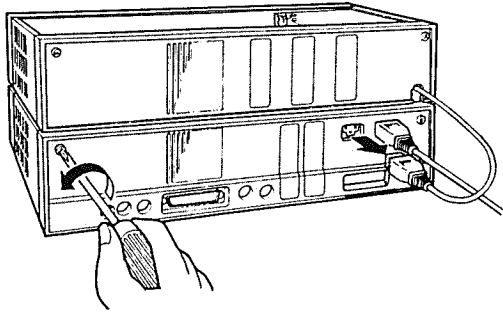

- (2) Carefully lift the expansion unit and remove it by pulling it towards the back.

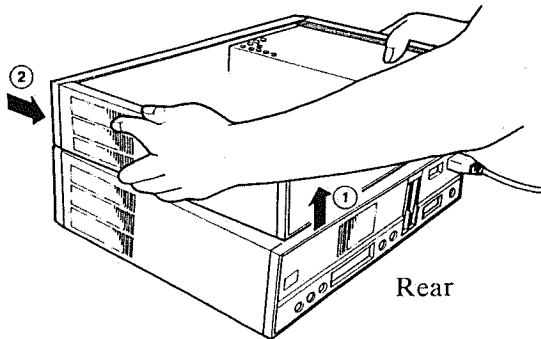

- 4** Remove the right cover plate on the back of the system unit by pushing it from the inside.

**Note:** If another option card is already installed and obstructs your work, remove that card, but be sure to reinstall it in its original position after installing the RS-232C card.

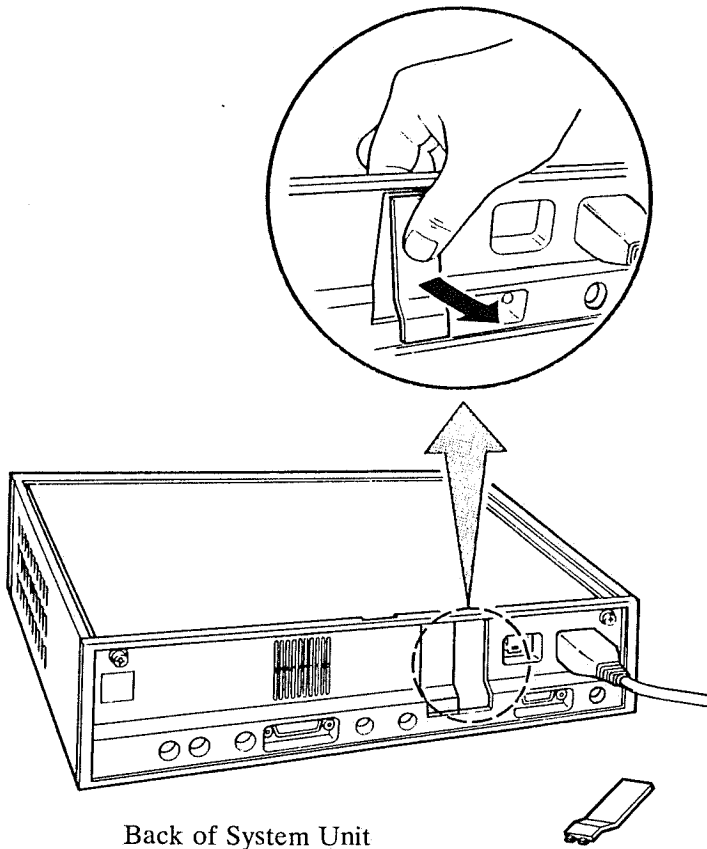

- 5** Insert the RS-232C card firmly in the system unit, passing the connector on the card through the opening from which the cover plate (window for the cable) was removed.
- ① Align the metal fitting on the top of the opening to the metal fitting on the top of the RS-232C card.
  - ② Push the connector on the bottom of the card down into the connector on the system unit.
  - ③ Fasten the card to the system unit with the screw provided.

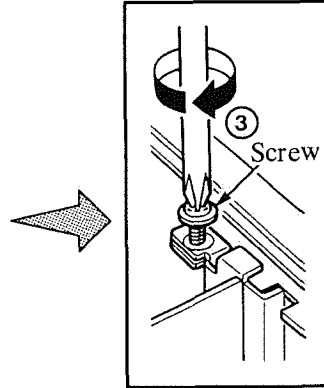
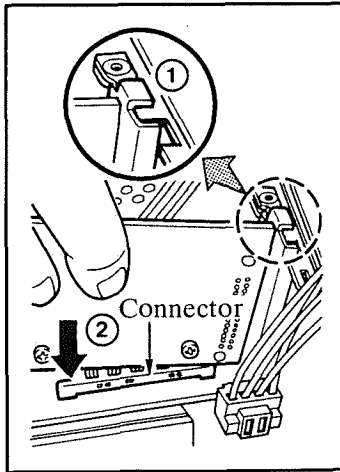

Connector positions  
of System Unit

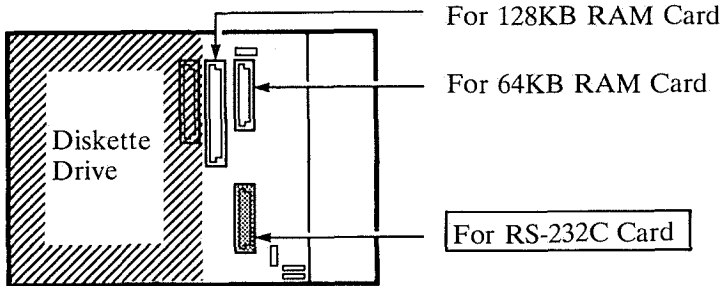

Back of System Unit

If the system had the expansion unit, reinstall it by referring to the *Expansion Unit Option Guide*.

If the system has the expansion board, reinstall it by referring to the *Expansion Board Option Guide*.

- 6** Close the top cover. First, press the top cover against the front of the unit and lower it. Then, tighten the screws on the back of the unit.

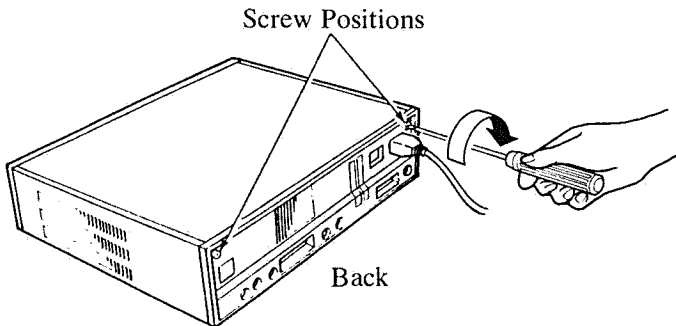
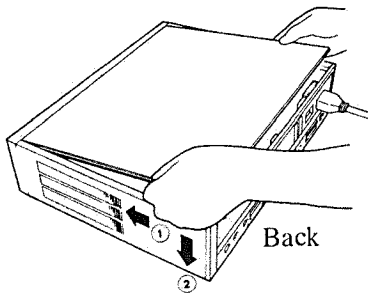

The RS-232C card is now installed.



- 7** If you have an RS-232C cable, connect one end of it to the cable connector on the RS-232C card as shown.

Fasten the cable connector by turning the upper and lower screws clockwise.

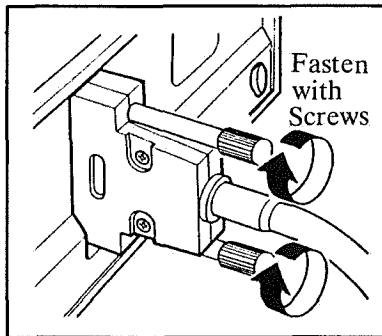
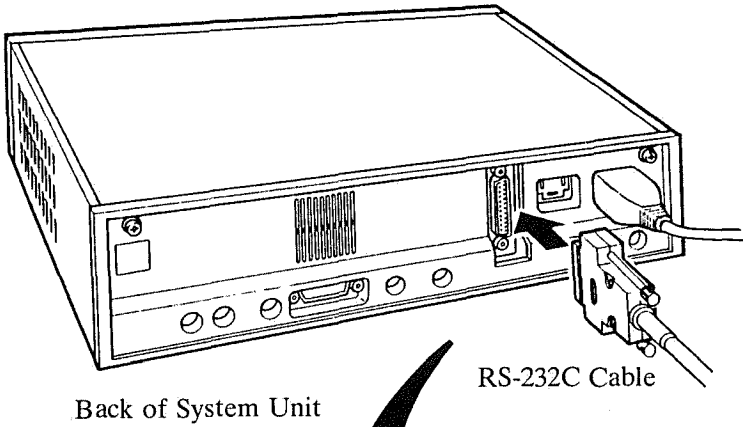

## Testing after Installation

---

This section describes how to verify the RS-232C card is installed correctly and operates normally. The same procedures can be used when a problem occurs when using the RS-232C card.

The **JX** System executes a self-diagnostic test automatically.

- 1 After installing the RS-232C card, connect the display to the system unit, insert the power plugs into a power outlet, turn the power on.

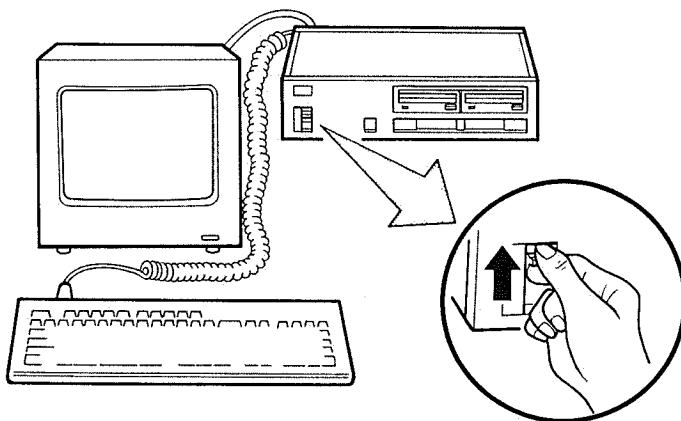

**2** Look at the screen that is displayed.

If the following error message is displayed at the bottom of the screen, the RS-232C card is not installed correctly. In this case, reinstall the card, following the installation instructions.

If the problem remains, it may be a problem with the card. Refer to Chapter 7, "Problem Determination Procedures" in the *Guide to Operations*.

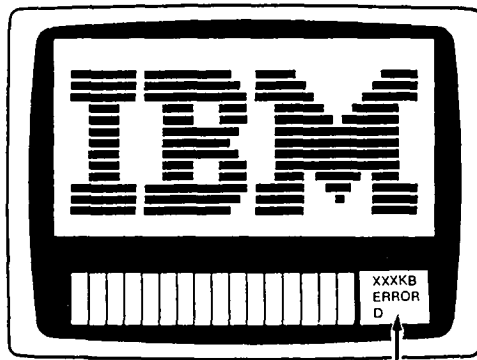

Error Message

If no error message is displayed, the RS-232C card has been installed correctly.

Perform the wrap test on the next page for a more complete test of the RS-232C card.

## Wrap Test

If you have the wrap connector, you can test the communication functions of the RS-232C card, including the cable connector, more thoroughly.

- 1 Turn the system unit power off and remove the power plug. If the RS-232C cable is not connected to the RS-232C card, refer to Step 7 of "Installation Instructions."

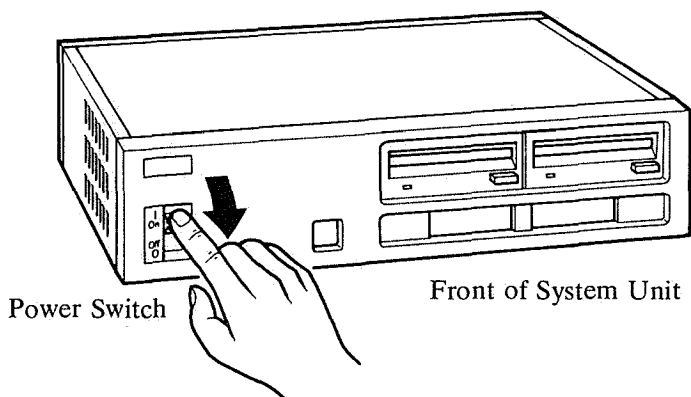

- 2 Connect the wrap connector to the other end of the RS-232C cable.

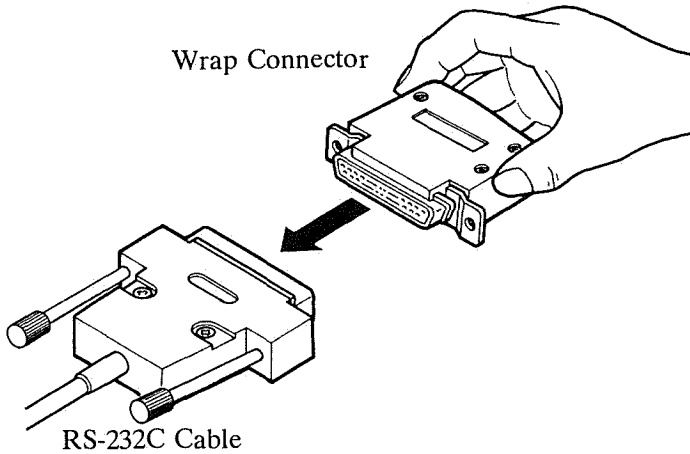

- 3 Remove any cartridges and diskettes from the system unit. Insert the system unit power plug into a power outlet and turn the power on.

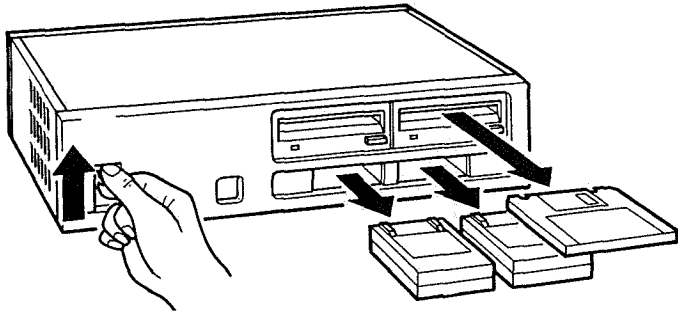

- 4** When the initial BASIC screen (shown below) is displayed, press and hold the **Ctrl** key and the **Alt** key at the same time, and then press the **Insert** key. The screen will be erased and the wrap test is now running.

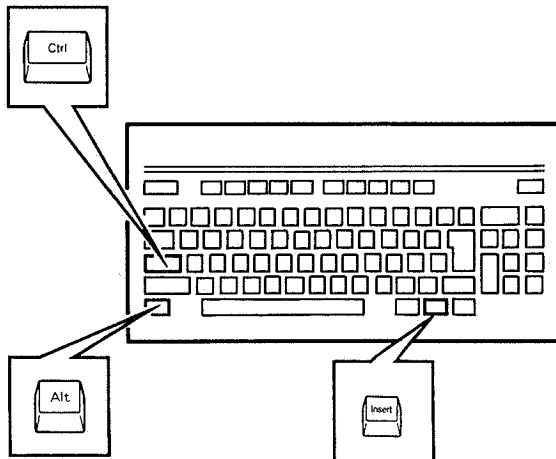
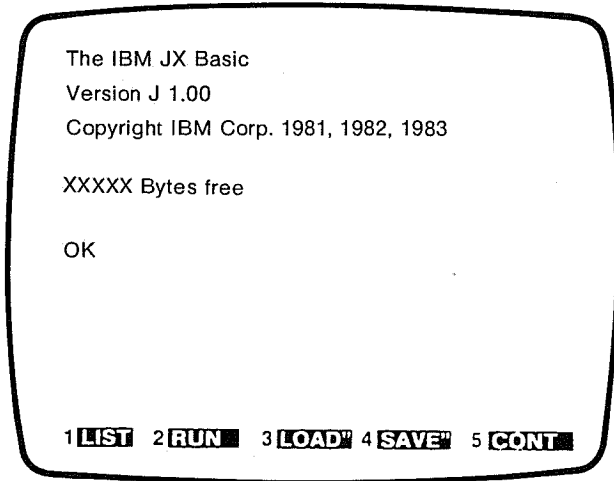

**5** If the test ends normally, the initial BASIC screen will be displayed again.

If any problem is detected by the test, the following error message will be displayed and a beep will sound twice.

If any Problem is detected, make sure that the cable is firmly connected and repeat the test. If the problem recurs, refer to Chapter 7, “Problem Determination Procedures” in *Guide to Operations*.

**Note:** If “ERROR J” is displayed, instead of “ERROR D”, ignore it.

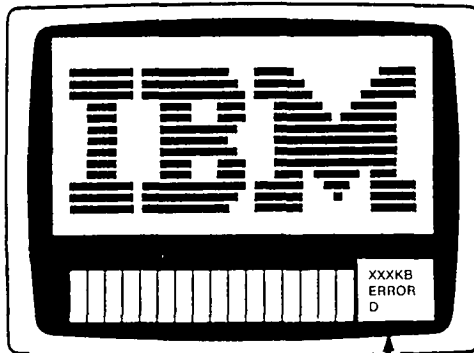

Error Message

If the initial BASIC screen is displayed, the wrap test was successful and the RS-232C card can be used for communications.

**Note:** Make sure that you conform to any laws or regulations required before using your RS-232C card for communications over public networks.

# Appendix A Connections of Pins-Wrap Test

The following drawing shows the connections of the pins when the RS-232C cable and the wrap connector are connected to the RS-232C card.

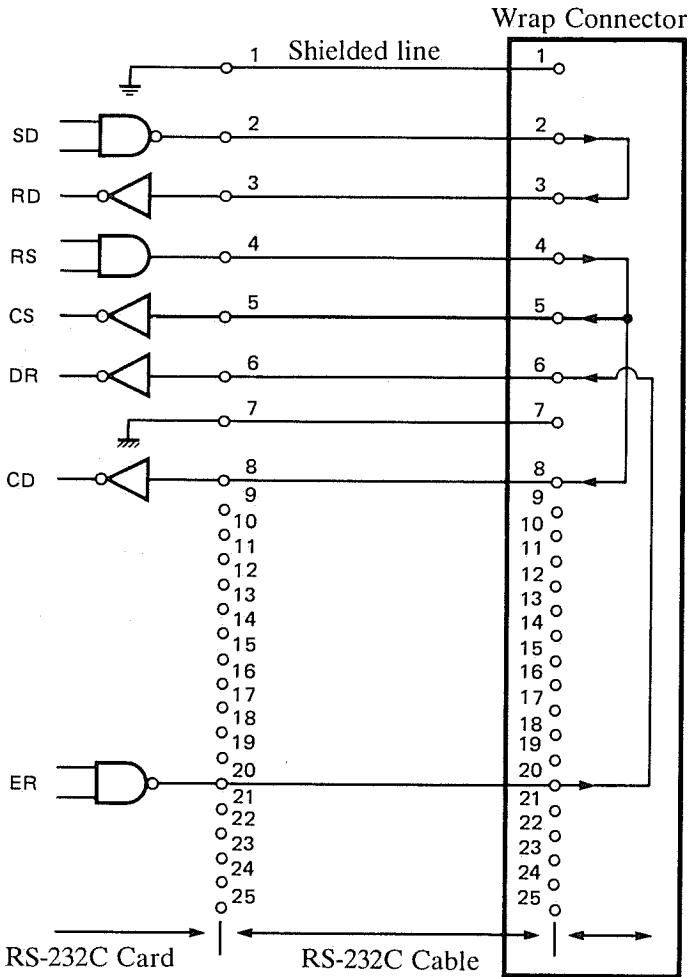



# Appendix B RS-232C Card Problem Determination

---

This section describes the actions to be taken when a problem occurs during actual communications.

If a problem occurs during communication, perform the installation test and the wrap test (if the wrap connector is provided) described in “Testing after Installation.”

If the problem still remains unsolved, perform the following procedures depending on the symptoms. If the problem still remains unsolved, refer to Chapter 7, “Problem Determination Procedures” in the *Guide to Operations*.

Symptom 1: A communication error message is displayed.

Communication parameters (baud rate, stop bit, parity, modem control, etc.) are invalid or the RS-232C card or cable has some problem. Take the following actions.

- Confirm the connection between the card and the cable.
- Confirm the parameters with the destination of communications.

Symptom 2: Data can neither be sent nor received

The RS-232C card or the cable has some problem. Take the following actions.

- Confirm the connection between the card and the cable.

Symptom 3: ERROR D is displayed as the result of the self-diagnostic test.

This error message does not imply a problem if the test was started using the , , and the  keys without attaching the wrap connector.









---

RS-232C Card Option Guide 115010-0 Printed in Japan

# Chapter 7. Problem Determination Procedures



# Before You Call for Help .....

☞ Are the Power switches ON?

☞ Are the Power plugs and the connectors firmly inserted?

If you have a suspected problem with your JX, check the following charts before proceeding.

Symptom	What to check	Remarks
<b>Display</b> <ul style="list-style-type: none"> <li>• Nothing appears.</li> <li>• No color is displayed.</li> <li>• The screen is dark.</li> </ul>	<ul style="list-style-type: none"> <li>• Brightness knob</li> </ul>	<ul style="list-style-type: none"> <li>• Turn the knob clockwise and the screen will get brighter.</li> </ul>
<b>Keyboard</b> <ul style="list-style-type: none"> <li>• No character is displayed.</li> <li>• Wrong characters are displayed.</li> <li>• Characters were displayed, but the command is not executed.</li> <li>• It occasionally makes "beep" sound.</li> </ul>	<ul style="list-style-type: none"> <li>• Battery</li> <li>• Distance from and direction to the system unit</li> <li>• Mode</li> </ul>	<ul style="list-style-type: none"> <li>• When the battery becomes low, characters will not be input correctly.</li> <li>• Operate in the correct input mode. (See Chapter 3.) Full-width alphanumerics cannot be used for a command.</li> </ul>
<b>No sound</b>	<ul style="list-style-type: none"> <li>• Volume knob</li> </ul>	<ul style="list-style-type: none"> <li>• Turn the knob clockwise to increase volume.</li> </ul>
<b>Diskette</b> <ul style="list-style-type: none"> <li>• It cannot be read.</li> <li>• It cannot be written.</li> </ul>	<ul style="list-style-type: none"> <li>• Diskette direction</li> <li>• Write-protect switch</li> <li>• Is it the correct diskette?</li> </ul>	<ul style="list-style-type: none"> <li>• Correct operations are described in Chapter 7.</li> <li>• <b>Diskettes are easily damaged. Try another diskette.</b></li> </ul>



**If you have a suspected problem with your JX, check the following charts before proceeding.**

Symptom	What to check	Remarks
<b>Joystick</b> • It does not work.	• Connector No. • Connected connector	• Two connectors (1 and 2) are provided.
<b>Cassette Tape</b> • It does not read. • It does not write.	• Adjust the volume and the tone • Tape position • Connected plug • Dirty head	• Is it connected correctly? • <b>Some types of tape recorder cannot read/write well.</b>
<b>Cartridge</b> • The program is not read.	• Insertion	• Is it completely inserted?
<b>RS-232C</b> • It cannot communicate.	• Connector • Destination • Modem	• Are the modem and the destination of communication normal?
<b>Cluster</b> • It cannot communicate.	• Connector • Address switches • Cable	• Is it connected correctly? • Are the switches set correctly? • Is the cable connected correctly?
<b>Printer</b> • It dose not print.	• Indicator Lights • Paper	• Any lights on? • Is the paper installed?
• If none of the above is applicable, • If you have checked, but are unsuccessful,		 Go to the subsequent pages.

# Any Problem? ..... When and what happened?

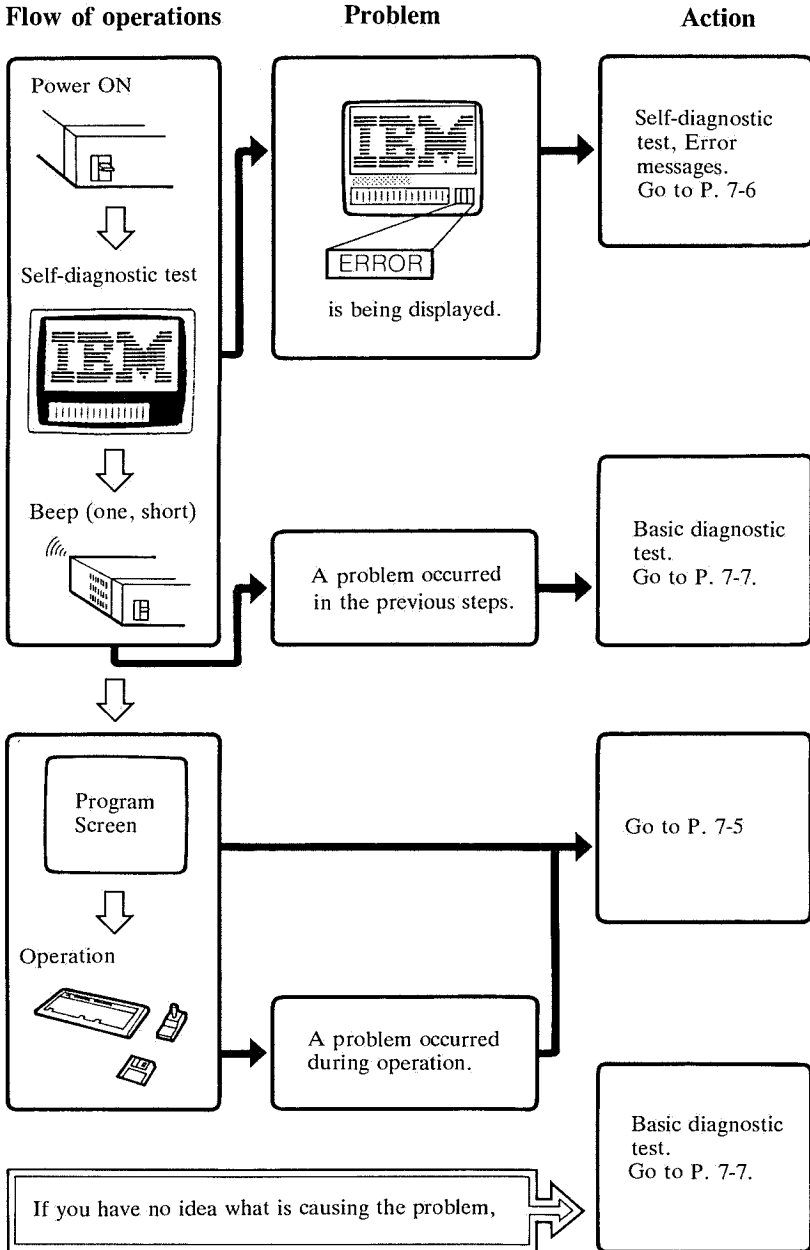

Any Problem? ..... This must be the source of the problem.

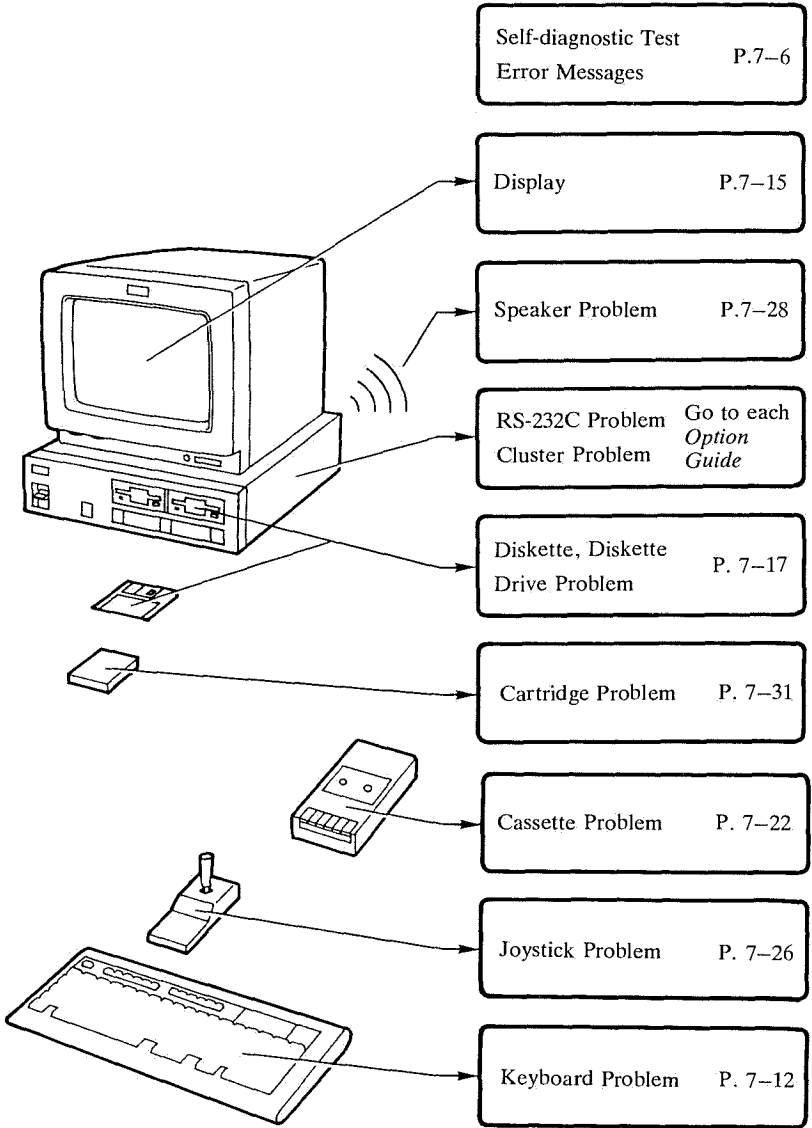

# Self-diagnostic Test Error Messages

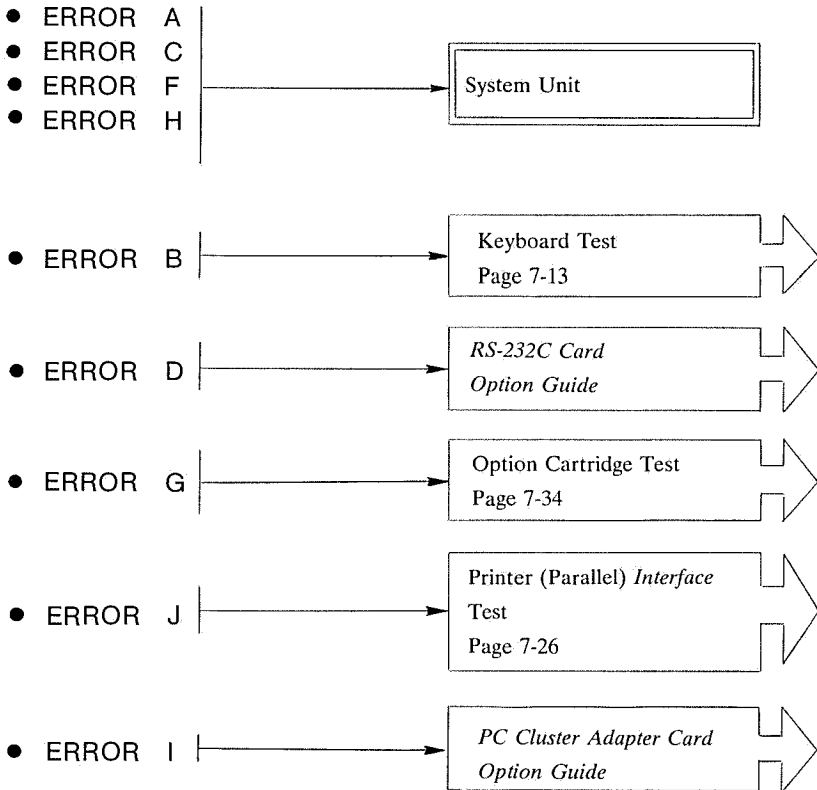
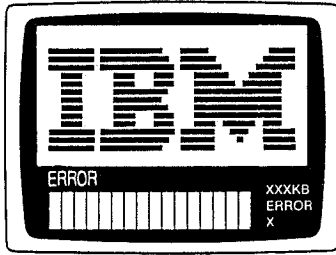

The device in  seems to have a problem.  
To request repair from the dealer, go to Page 7-37.

# Basic Diagnostic Test

- 1 Turn the Power switch on the system unit and all the options off. Disconnect the power plugs from the receptacles.

**Note:** Disconnect all non-IBM products. Also, remove the cartridge and the diskette.

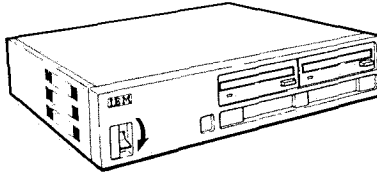

- 2 Make sure that the cables of the IBM products are connected correctly to the system unit.

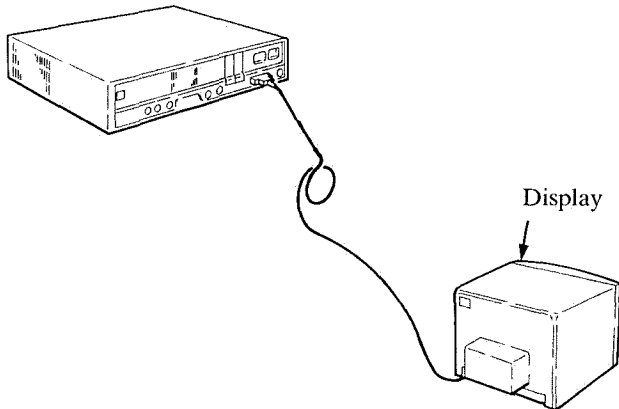

- 3** Using a lamp, etc., make sure that power is being supplied to the receptacle.

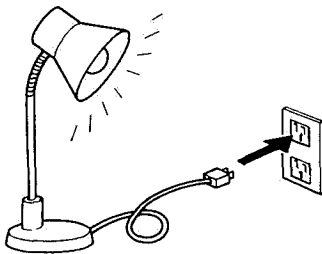

- 4** Turn the Brightness knob on the display clockwise. Turn the display on.

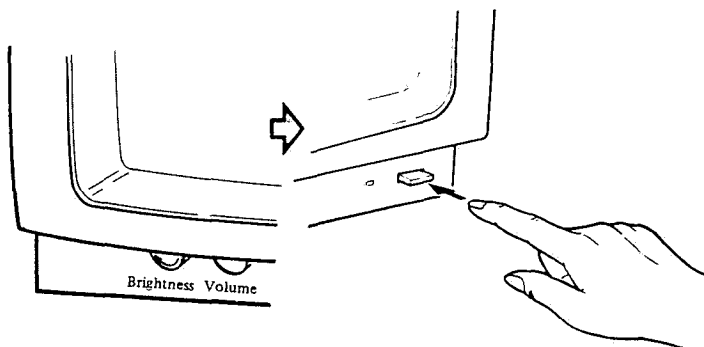

- 5 Insert the system unit power plug into the receptacle (checked in step 3) and turn the power on.

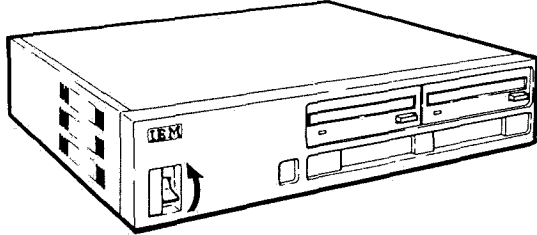

If the system is working correctly, the following will occur.

The test screen is displayed.

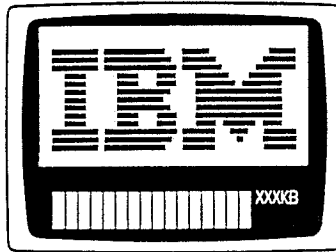

A beep sounds once.

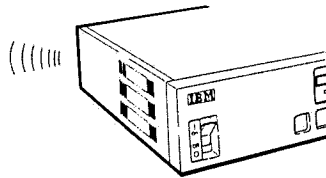

The initial BASIC screen is displayed.

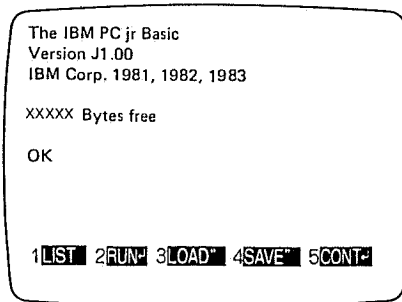

The basic diagnostic test is completed. If no error is detected during the test, the system is working correctly.



## Basic Diagnostic Test Problem Determination Table

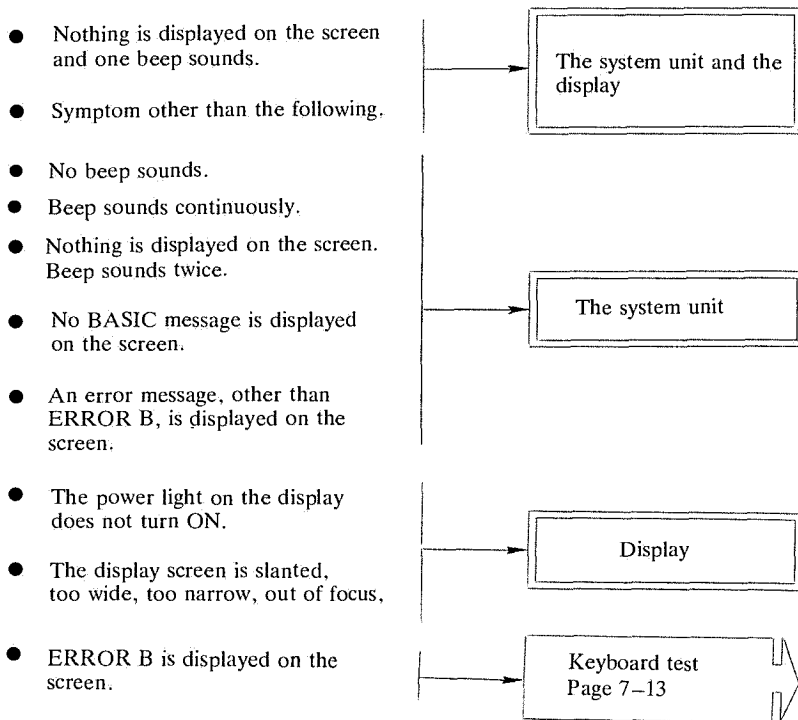

The problem seems attributable to the device shown in . To request repair by the dealer, go to Page 7-37.

## Keyboard Problem

If any of the following occurs, test the keyboard.

Example of Symptom
<ul style="list-style-type: none"><li>● Nothing can be input from the keyboard.</li><li>● Data can sometimes be input from the keyboard.</li><li>● Input code from the keyboard is changed.</li><li>● Data is input from the keyboard only once, but the data is displayed more than once.</li><li>● When the keyboard cable is connected, the keyboard malfunctions.</li><li>● When a key is pressed, it makes a “beep, beep” sound.</li></ul>

## Keyboard Test

- 1 Turn the system unit power switch off. Take out the cartridge and diskette from the system unit. Turn the system unit power switch on.

**Note:** If ERROR B is displayed, press   
If operation cannot be continued, refer to  
“Keyboard Problem Determination Table” (page  
7-14).

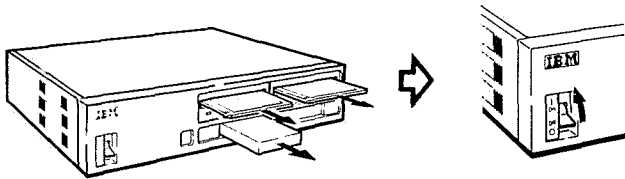

- 2** Press the key you want to test. Make sure that the character or the symbol written on the key is displayed correctly on the screen.

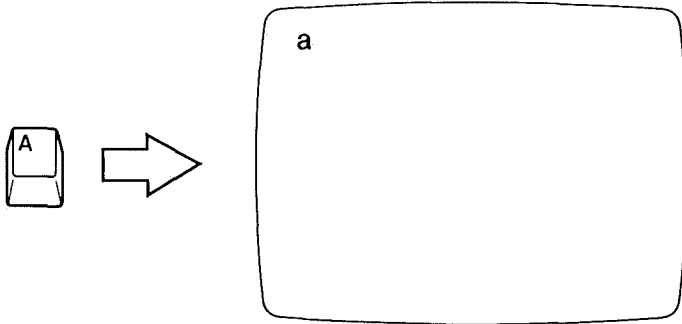

The keyboard test is completed. If no problem has been found during this test, the keyboard is working correctly.

### Keyboard Problem Determination Table

<ul style="list-style-type: none"> <li>● ERROR B is displayed by the Self-diagnostic Test.</li> </ul>	→	System unit
<ul style="list-style-type: none"> <li>● Data from the keyboard is changed.</li> <li>● When a key is pressed, it makes a sound like “beep, beep.” No data can be input from the keyboard.</li> <li>● Data is input when no key is pressed.</li> <li>● Symptoms other than the above.</li> </ul>	→	System unit and keyboard (keyboard cable)

The problem seems attributable to the device shown in . To request repair by the dealer, go to Page 7-37.

# Display Problem

If any of the following occurs, refer to the Display Problem Determination Table on the next page.

Examples of Symptom	
● The screen is too dim.	● The screen is monochromatic when the mode is color.
● The screen is too wide or too narrow.	● Some specific color cannot be displayed.
● The screen is out of focus.	● Vertical patterns appear on the screen.
● The screen is shrunken or elongated.	● The screen is tilted.

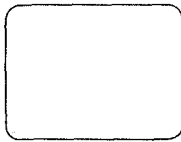

Too Dim

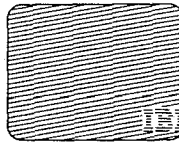

Too Wide

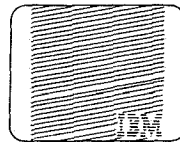

Too Narrow



Out of Focus

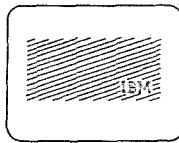

Shrunken

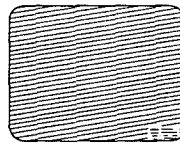

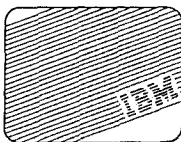

Characters shifted left or right or up and down off the display area

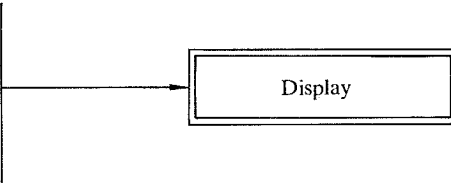
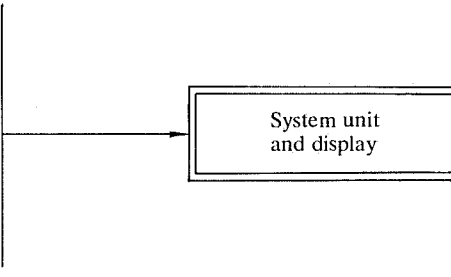

Tilted

## Display Problem Determination Table

<ul style="list-style-type: none"><li>● The screen is out of focus.</li><li>● The screen is too dim, too wide, or too narrow.</li><li>● The screen is tilted, shrunken, or elongated.</li></ul>	
<ul style="list-style-type: none"><li>● The screen remains completely dark.</li><li>● Scan lines appear, but nothing is displayed on the screen.</li><li>● The screen keeps rolling.</li><li>● The screen displays unexpected data.</li><li>● Symptoms other than the above.</li></ul>	

The Problem seems attributable to the device shown in . To request repair by the reader, go to page 7–37.

## Diskette Drive Problem

If any of the following occurs, test the diskette drive.

### Examples of Symptom

- An error message indicating diskette read error occurs when DOS is started.
- An error message is displayed when attempting to write or read the diskette.
- A file which was created on a different diskette drive cannot be used.
- An error message is displayed when writing or reading a specific file.

## Diskette Drive Test

- 1 Turn the system unit power switch off. Remove any cartridges and diskettes from the system unit.

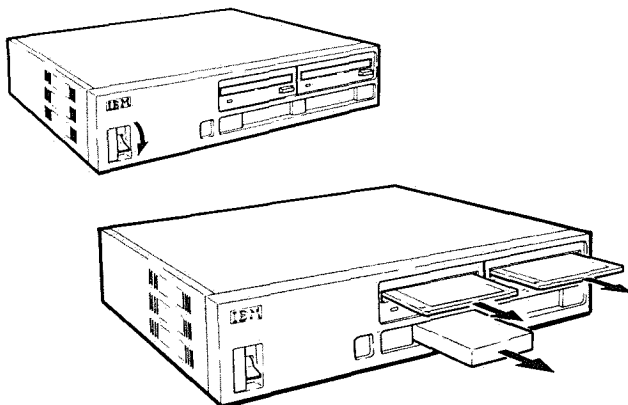

- 2 Insert the DOS diskette in diskette drive A until it clicks. Turn the system unit power switch on.

**Note:** Do not use a master DOS diskette for this test. It is recommended to set the DOS diskette “write protected.”

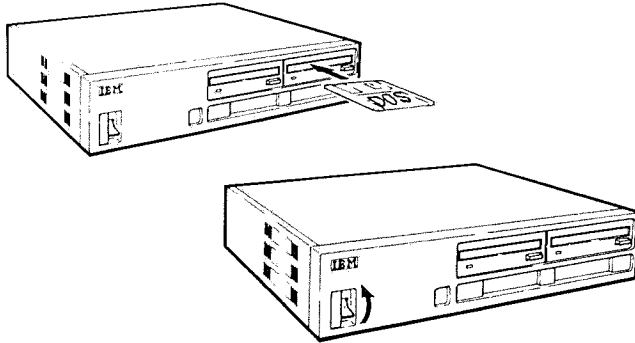

- 3 DOS will start. The following message will be displayed after the test screen. Input the date and the time according to the message on the screen.

```
Current date is Tue 1-01-1980
Enter new date:
Current time is 0:00:47.62
Enter new time:
```



- 4** Type **DIR** and make sure that the diskette directory can be read.

```
MORE      COM      384    10-20-83  12:00P
BASIC     COM     16256   10-20-83  12:00P
BASICA    COM     26112   10-20-83  12:00P
DEBUG     COM     11904   10-20-83  12:00P
SAMPLES   BAS      3067    10-20-83  12:00P
ART       BAS      1920    10-20-83  12:00P
MUSIC     BAS     10291   10-20-83  12:00P
MUSICA    BAS     13292   12-12-84  12:00P
MDRTGAGE  BAS      6272    10-20-83  12:00P
CDLORBAR  BAS      1536    10-20-83  12:00P
DONKEY    BAS      3584    10-20-83  12:00P
CIRCLE    BAS      1664    10-20-83  12:00P
PIECHART  BAS      2304    10-20-83  12:00P
SPACE     BAS      1920    10-20-83  12:00P
BALL      BAS      2048    10-20-83  12:00P
COMM      BAS      4352    10-20-83  12:00P
GRAPHICX  COM       884    12-05-84  12:00A
SWAP_AC   EXE       627    12-10-84   2:48P
INSTALL   COM     6779    6-03-84   12:00P
PCJRMEM   COM     1199    6-11-84  11:04A
PCJRMEM   DOC    19055    6-03-84  12:00P
RAMDISK   COM       816    6-03-84  12:00P
41 File(s)  75776 bytes free
```

A>

- 5** Get a diskette for copying and make sure that it is enabled to write.

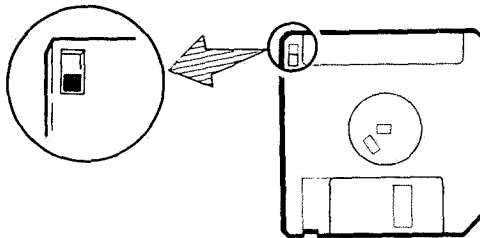

**6** Type in the appropriate command for the diskette drive to be tested. Follow the prompts that are displayed.

Diskette drive to be tested	Command to be Typed
A	DISKCOPY
B	DISKCOPY A: B:
C	DISKCOPY A: C:

**7** If the following prompt is displayed, type **N**.

Copy complete  
Copy another <Y/N> ?

The diskette drive test is completed. If no problem is found during this test, the diskette drive is working correctly.

## Diskette Drive Problem Determination Table

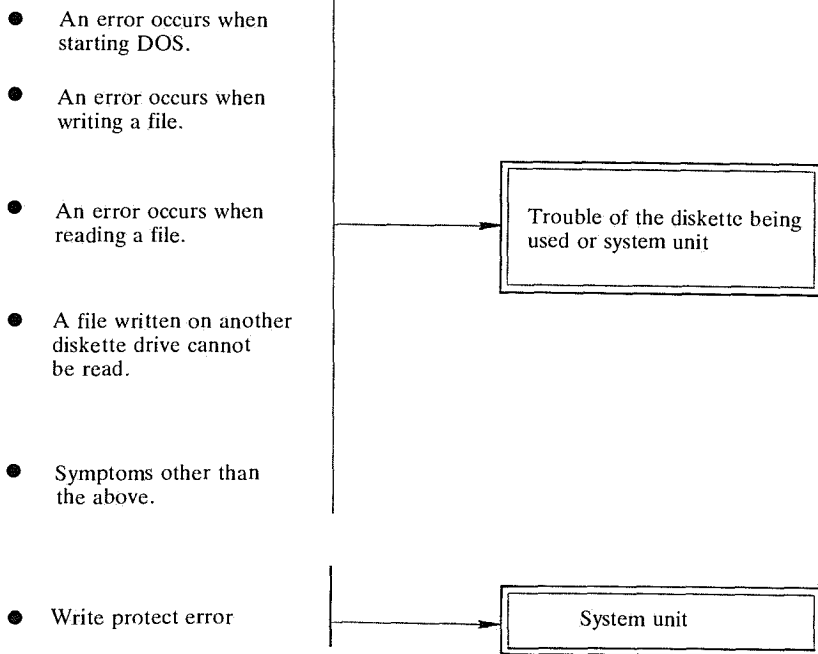

The problem seems attributable to the device shown in . To request repair by the dealer, go to Page 7-37.

## Cassette Interface Problem

If any of the following occurs, test the cassette interface.

### Examples of Symptom

- An error message is displayed when trying to read or write a file from the cassette tape recorder.
- The cassette tape recorder cannot be remotely controlled.
- Writing to or reading from the cassette tape recorder is not possible.

## Cassette Interface Test

- 1 Turn off the system unit power. Remove any cartridges and diskettes from the system unit. Turn on the system unit power.

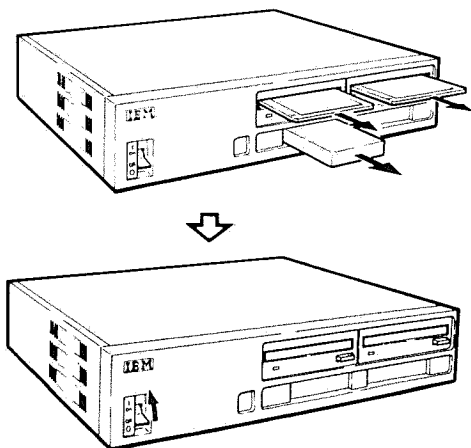

- 2** Make sure that the cassette tape recorder is connected to the system unit. Set the cassette tape recorder, so it is ready to record.

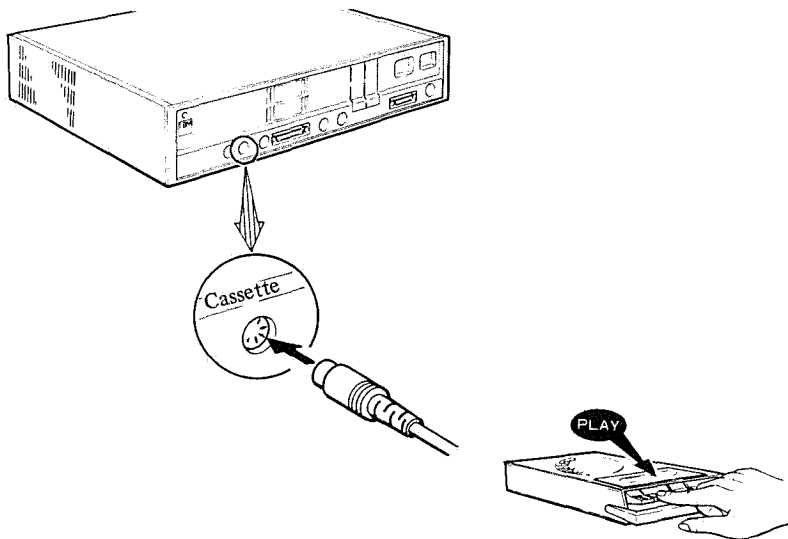

- 3** Type in the following sample program from the keyboard.

### Sample program

```
10 CLS
20 FOR I = 1 TO 500
30 PRINT "H";
40 NEXT I
50 END
```



## Cassette Interface Problem Determination Table

- SAVE cannot be executed.
- As error message is displayed when trying to LOAD a file.
- LOAD cannot be executed.

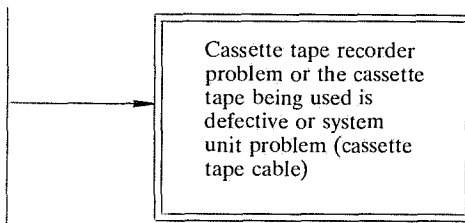

The problem seems to be attributable to the device shown in . To request repair by the dealer, go to Page 7-37.

# Joystick Problem

## Joystick Test

- 1 Turn off the system unit power. Disconnect the joystick from the current connector and connect it to the other connector.

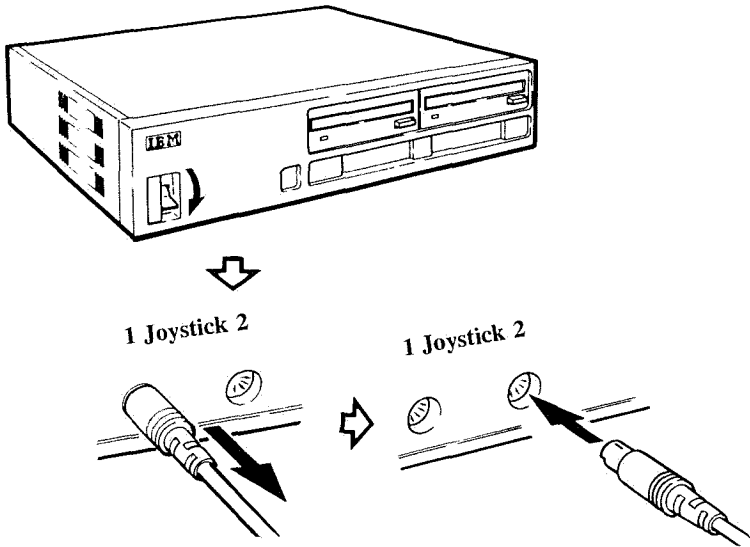



- 2 Turn on the system unit power. Execute the program which had the problem to check the operation of the joystick.

The joystick test is completed. If no problem is found during this test, the joystick is working correctly.

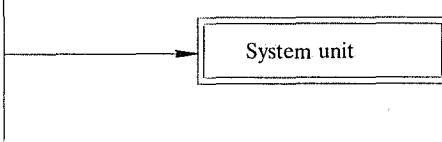
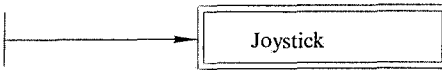

## Joystick Problem Determination Table

- A problem occurs when the joystick is connected to either one of the joystick connector. 
- Symptoms other than the above 

The problem seems attributable to the device shown in . To request repair by the dealer, go to Page 7-37.

## Speaker Problem

If any of the following occurs, perform a sound test.

### Examples of Symptom

- SOUND or PLAY command cannot be executed correctly in BASIC.
- The display, the external speaker, or the built-in system unit speaker makes no sound.
- The display, the external speaker, or the built-in system unit speaker makes noise

## Sound Test

- 1 Turn off the system unit power. Remove any cartridges and diskettes from the system unit. Turn the system unit power on.

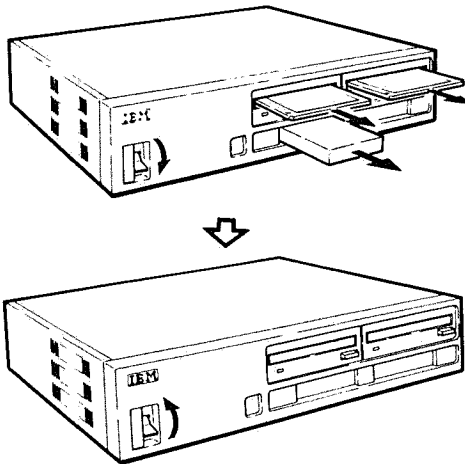

- 2** Type in either of the following sample programs, depending on whether the built-in system unit speaker or the built-in display speaker is to be tested.

Sample program for testing the built-in system unit speaker:

```
10 SOUND OFF:BEEP ON
20 A$="<CDEFGAB>C"
30 PLAY A$
```

Sample program for testing the display or the external speaker:

```
10 SOUND ON:BEEP OFF
20 A$="<CDEFGAB>C"
30 PLAY A$
```

- 3** Set the volume knob to the medium position and press PF2 key to execute the program. The built-in system unit speaker has no volume control.

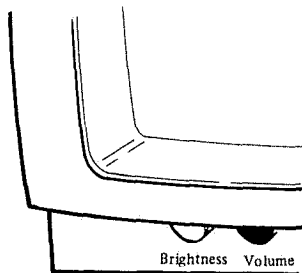

The sound test is completed. If no problem is found during this test, the speaker is working correctly.

## Sound Test Problem Determination Table

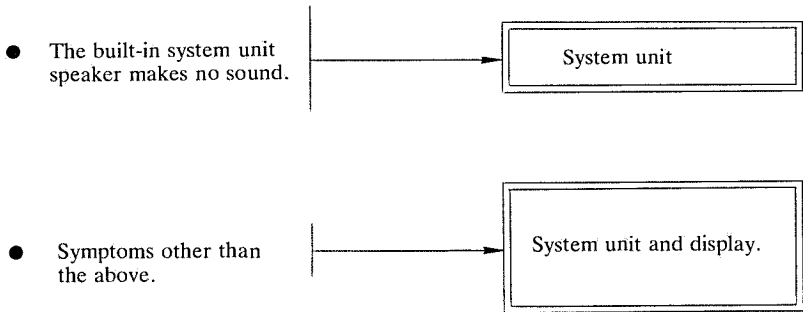

The problem seems attributable to the device shown in . To request repair by the dealer, go to Page 7-37.

## Option Cartridge Problem

If any of the following occurs, perform the option cartridge test.

### Examples of symptom

- The cartridge does not operate correctly.
- "ERROR" is displayed as the result of the self-diagnostic test.

## Option Cartridge Test

- 1 Remove any diskettes from the system unit and insert a cartridge in either of the cartridge slots.

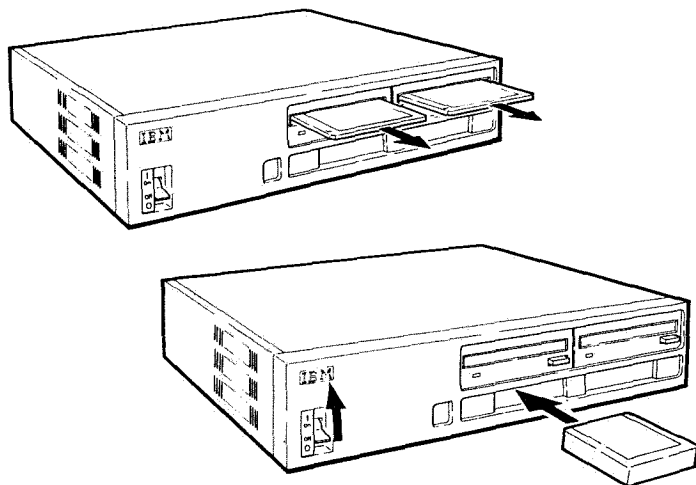

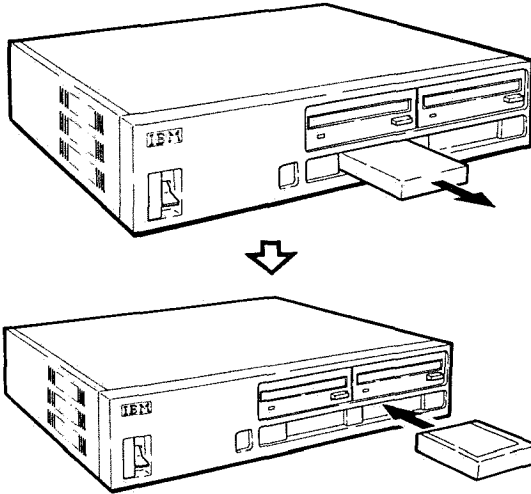

- 2 If control is not transferred to the cartridge, or if “ERROR” is displayed, insert the cartridge in the other slot and check whether it operates correctly.

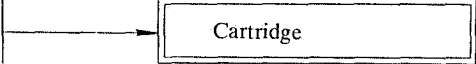
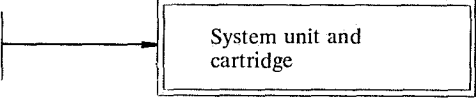

The option cartridge test is completed. If no problem is found during this test, the option cartridge is working correctly.

# Option Cartridge Trouble-Shooting Table

- A problem occurs in only one of the cartridge slots. 
- A problem occurs in both cartridge slots. 

The problem seems attributable to the device shown in  . To request repair by the dealer, go to Page 7-37.

## Printer (Parallel) Interface Problem

If any of the following occurs, test the printer (parallel) interface.

### Examples of Symptom

- The printer does not print.
- It does not print correct characters.
- Printer Ready light, if any, does not light up.

## Printer (Parallel) Interface Problem Test

- 1 Turn off the system unit power and disconnect the printer cable.

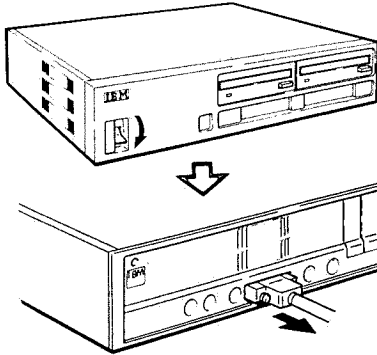



- 2 Remove any cartridges and diskettes from the system unit. Turn the system unit power switch on.

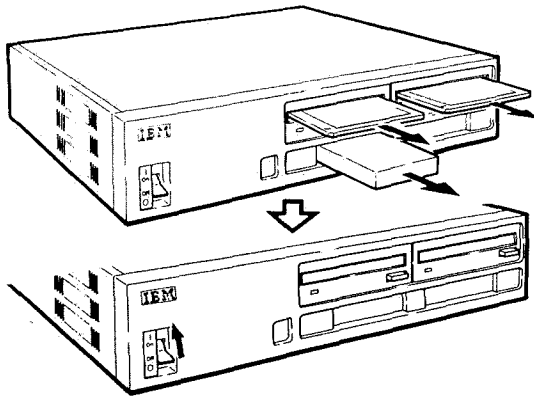

- 3 When the initial screen of BASIC appears, press and hold **Ctrl** and **Alt** , and then press **Insert** . The test screen will appear.

**Note:** If RS-232C card is installed, “ERROR D” will be displayed. This does not indicate a problem.

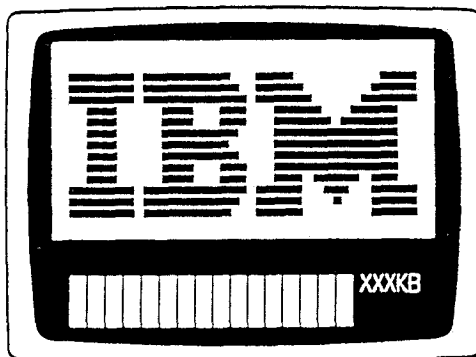

The parallel interface test is completed. If “ERROR J” is not displayed, refer to your printer’s Operation Guide.

## Printer (Parallel) Interface Problem Determination Table

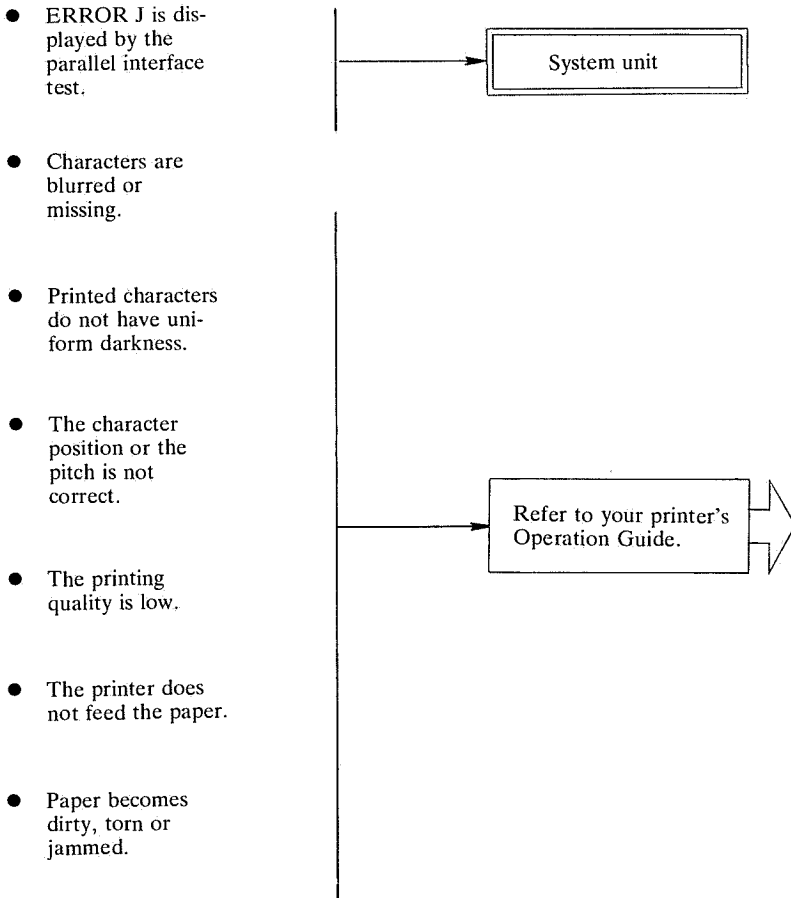

The problem seems attributable to the device shown in . To request repair by the dealer, go to page 7-37.

# To Request Service by the Dealer

---

If your **JX** system has a problem and must be repaired by the dealer, perform the following steps.

1. Complete the “Problem Report Form” which is found at the end of this chapter.
2. Turn off the power of all the devices that are connected to the **JX** system unit. Remove all power plugs.
3. Request repair of the device that seems to have a problem.



# Problem Report Form

1. Which device has a problem?

- |                                      |   |
|--------------------------------------|---|
| <input type="checkbox"/> System unit | <input type="checkbox"/> Display            |
| <input type="checkbox"/> Keyboard    | <input type="checkbox"/> Other IBM products |

2. Software being used?

- |  |                                    |
|--|------------------------------------|
| <input type="checkbox"/> DOS             | <input type="checkbox"/> Multiplan |
| <input type="checkbox"/> Pascal          | <input type="checkbox"/> FORTRAN   |
| <input type="checkbox"/> Macro Assembler | <input type="checkbox"/> Others    |

3. Enter the operational environment

- Did the trouble occur during system installation?  
(During installation/normal operation)

- Time that passed between power ON and problem occurrence:

About \_\_\_\_\_ hours

- Average daily operations:

About \_\_\_\_\_ hours

- Place of operation \_\_\_\_\_

- Room temperature at the time of problem occurrence:

About \_\_\_\_\_ °C



---

# Expansion RAM Card Option Guide

---

This manual explains the procedures for installing the 128KB, 256KB and 384KB RAM cards.

---

## Warning

---

The IC may be damaged if you touch it when you are electrostatically charged. Before touching an IC, be sure to always discharge any static electricity on you by touching a steel cabinet, etc., with your hand. For safety, do not do anything that is not written in this manual.

---

This manual consists of the following:

Before the Installation .....	1
Parts List .....	3
Tools Required .....	4
Installation of the 128KB RAM Card .....	5
Installation of the 256KB RAM Card .....	10
Installation of the 384KB RAM Card .....	13
Testing after Installation .....	14
Supplementary Information .....	16

**First Edition** (August 1985)

Changes are periodically made to the information herein; these changes will be incorporated in new editions of the publication. It is possible that this material may contain references to, or information about, IBM products (machines and programs), programming, or services that are not announced in your country. Such references or information must not be construed to mean that IBM intends to announce such IBM products, programming, or services in your country.



# Before the Installation

---

This manual explains the procedures for installing the following three RAM cards:

- 128KB RAM card
- 256KB RAM card
- 384KB RAM card

The installation method will depend on the memory structure and the hardware configuration of the **JX**.

This manual uses a flow chart to explain the procedures for installing each card. Follow the applicable flow chart. The terms used in the flow charts are explained below.

**Configuration:** Memory configuration of your system

**Jumper:** To install the 128KB RAM card, the jumper must be connected on the card. Their positions are explained wherever necessary.

**Expansion Unit:** The Expansion Unit is installed on top of the System Unit and required for two or more expansion RAM cards.

**Expansion Board:** The Expansion Board is necessary for installing two or more expansion RAM cards. It has four connectors.

**System Board:** The System Board is a circuit board installed in the System Unit. It also has the connectors for the RAM cards.

After reading this section, confirm the parts that you received by referring to “Parts List” and install the cards.

The installation procedures are explained in the following sequence.

128KB RAM card .....	p. 5
256KB RAM card .....	p. 10
384KB RAM card .....	p. 15

If you have purchased the Expansion Board with the expansion RAM cards, install the Expansion Board first.

# Parts List

---

## RAM Cards

128KB RAM card: ID 6454427

256KB RAM card: ID 6454428

384KB RAM card: ID 6454429

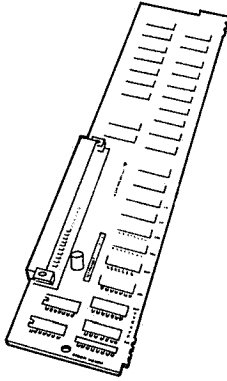

**If the card has been damaged during shipment, please contact your dealer.**

## Tools Required

---

- Medium-size Phillips screwdriver

# Installation of the 128KB RAM Card

---

The 128KB RAM card can be installed in four ways. Compare the memory configuration of your system with the following illustration and proceed to the applicable procedure.

Memory Configuration	Installation Procedures	Remarks								
<b>1</b> <table border="1" style="margin-left: 20px;"> <tr> <td colspan="2" style="background-color: #cccccc;">128KB</td> </tr> <tr> <td>Base 64KB</td> <td>Add'l 64KB</td> </tr> </table>	128KB		Base 64KB	Add'l 64KB	See Page 6.					
128KB										
Base 64KB	Add'l 64KB									
<b>2</b> <table border="1" style="margin-left: 20px;"> <tr> <td colspan="2" style="background-color: #cccccc;">128KB</td> </tr> <tr> <td colspan="2">128KB</td> </tr> <tr> <td>Base 64KB</td> <td>Add'l 64KB</td> </tr> </table>	128KB		128KB		Base 64KB	Add'l 64KB	See Page 7.	The expansion board is necessary.		
128KB										
128KB										
Base 64KB	Add'l 64KB									
<b>3</b> <table border="1" style="margin-left: 20px;"> <tr> <td colspan="2" style="background-color: #cccccc;">128KB</td> </tr> <tr> <td colspan="2">128KB</td> </tr> <tr> <td colspan="2">128KB</td> </tr> <tr> <td>Base 64KB</td> <td>Add'l 64KB</td> </tr> </table>	128KB		128KB		128KB		Base 64KB	Add'l 64KB	See Page 8.	The expansion board is necessary.
128KB										
128KB										
128KB										
Base 64KB	Add'l 64KB									
<b>4</b> <table border="1" style="margin-left: 20px;"> <tr> <td colspan="2" style="background-color: #cccccc;">128KB</td> </tr> <tr> <td colspan="2">256KB</td> </tr> <tr> <td>Base 64KB</td> <td>Add'l 64KB</td> </tr> </table>	128KB		256KB		Base 64KB	Add'l 64KB	See Page 9.	The expansion board is necessary.		
128KB										
256KB										
Base 64KB	Add'l 64KB									

- Notes:**
1.  indicates the RAM card to be installed.
  2. "Base 64KB" means the 64KB memory that comes with the system.
  3. "Add'l 64KB" means 64KB RAM card (already mounted).

# Installation Procedure for Memory Configuration 1

Proceed according to the flow chart.  
The figures in parentheses indicate the pages to be referred to.

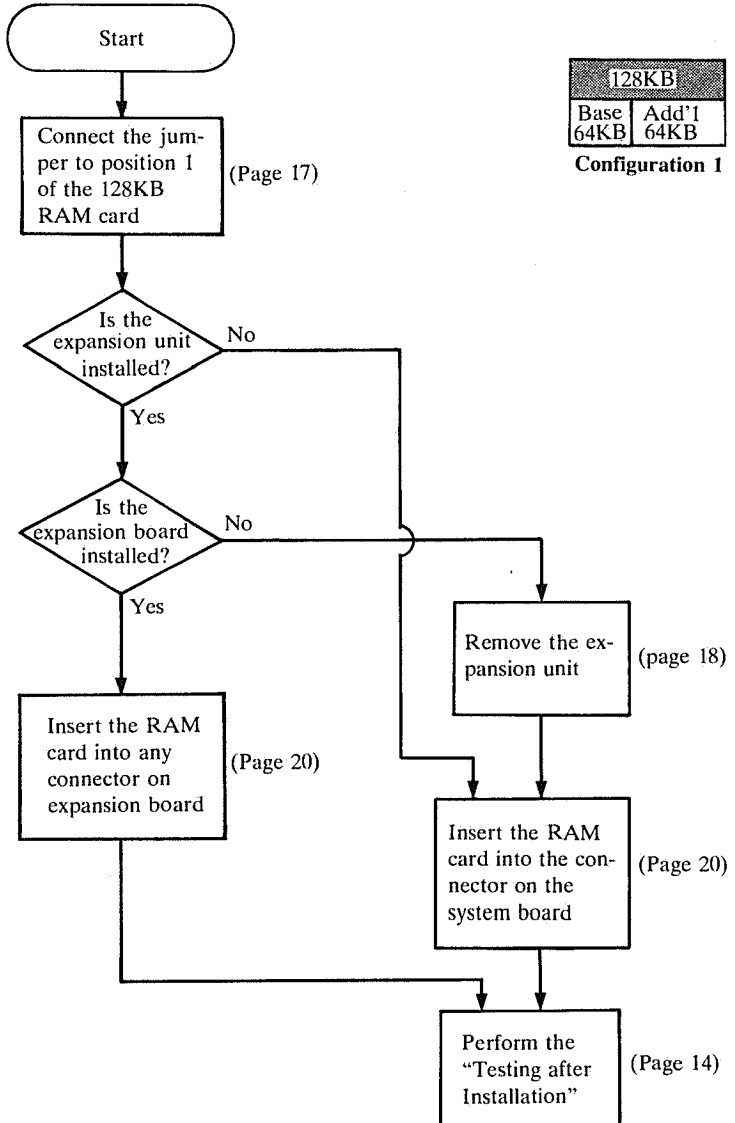

# Installation Procedure for Memory Configuration 2

---

Proceed according to the flow chart.

The figures in parentheses indicate the pages to be referred to.

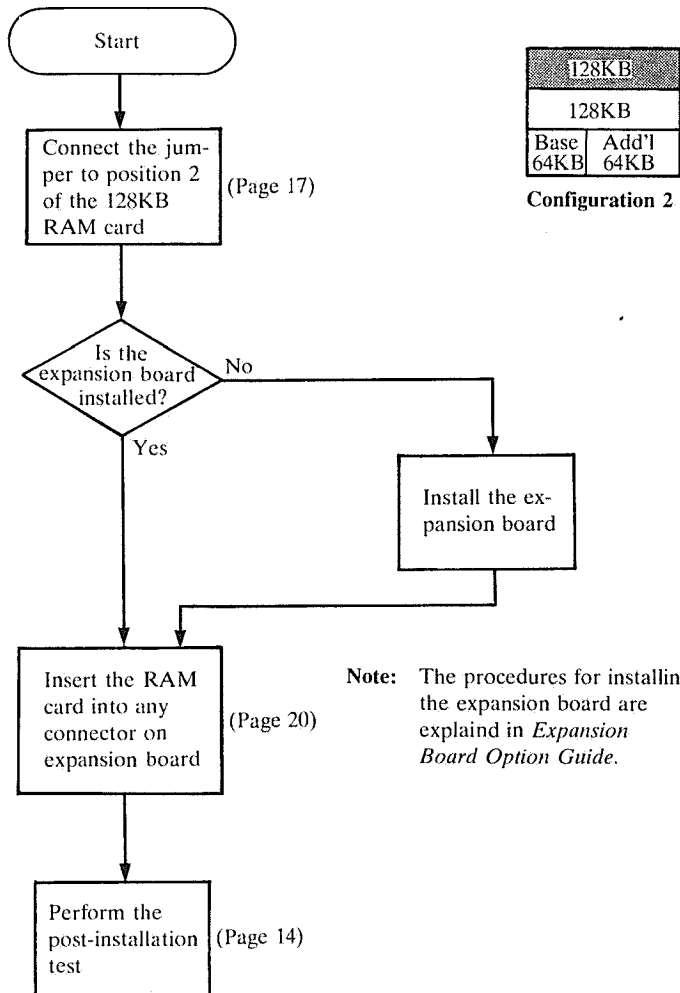

# Installation Procedure for Memory Configuration 3

---

Proceed according to the flow chart.  
The figures in parentheses indicate the pages to be referred to.

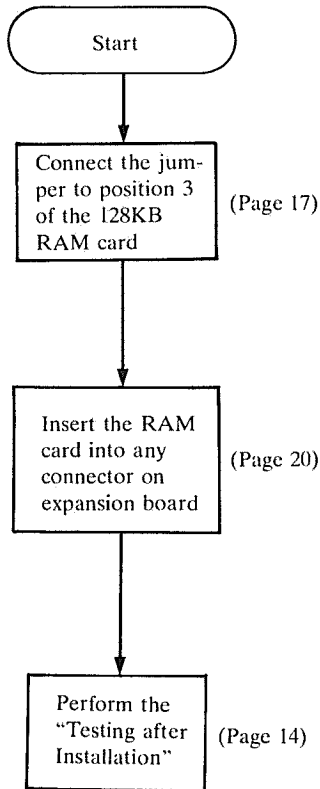

128KB	
128KB	
128KB	
Base 64KB	Add'l 64KB

Configuration 3



# Installation Procedure for Memory Configuration 4

---

Proceed according to the flow chart.  
The figures in parentheses indicate the pages to be referred to.

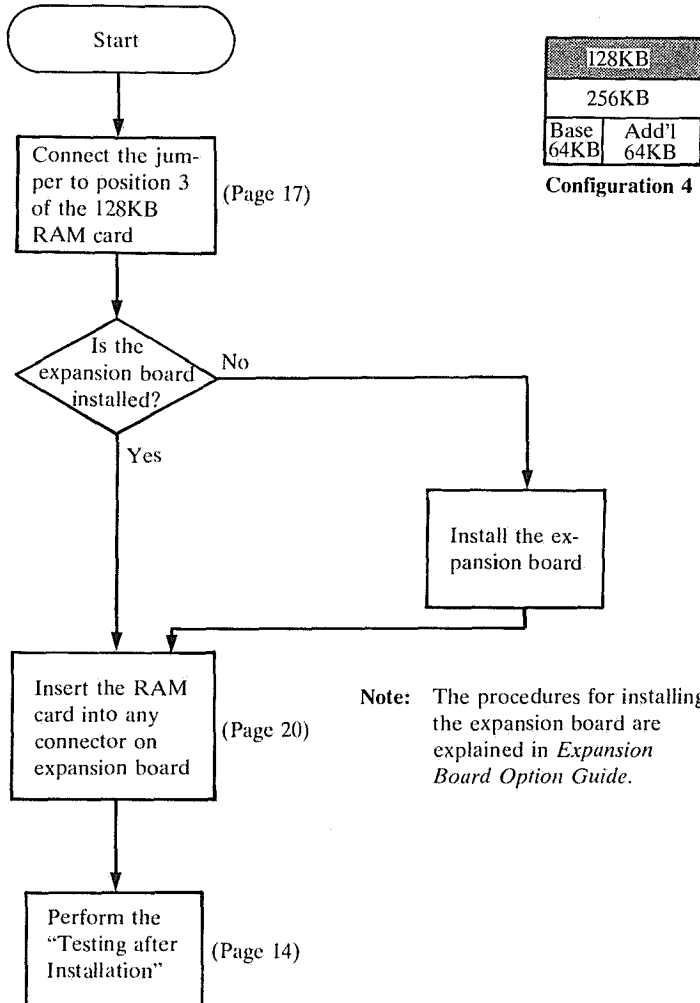

# Installation of the 256KB RAM Card

---

The 256KB RAM card can be installed in two ways. Compare the memory configuration of your system with the following illustration and proceed to the applicable procedure.

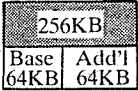
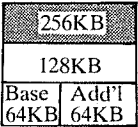
Memory Configuration	Installation Procedures	Remarks
<b>1</b> 	See Page 11	
<b>2</b> 	See Page 12	The expansion board is necessary.

- Notes:**
1.  indicates the RAM card to be installed.
  2. “Base 64KB” means the 64KB memory that comes with the system.
  3. “Add’l 64KB” means 64KB RAM card (already mounted).

# Installation Procedure for Memory Configuration 1

---

Proceed according to the flow chart.

The figures in parentheses indicate the pages to be referred to.

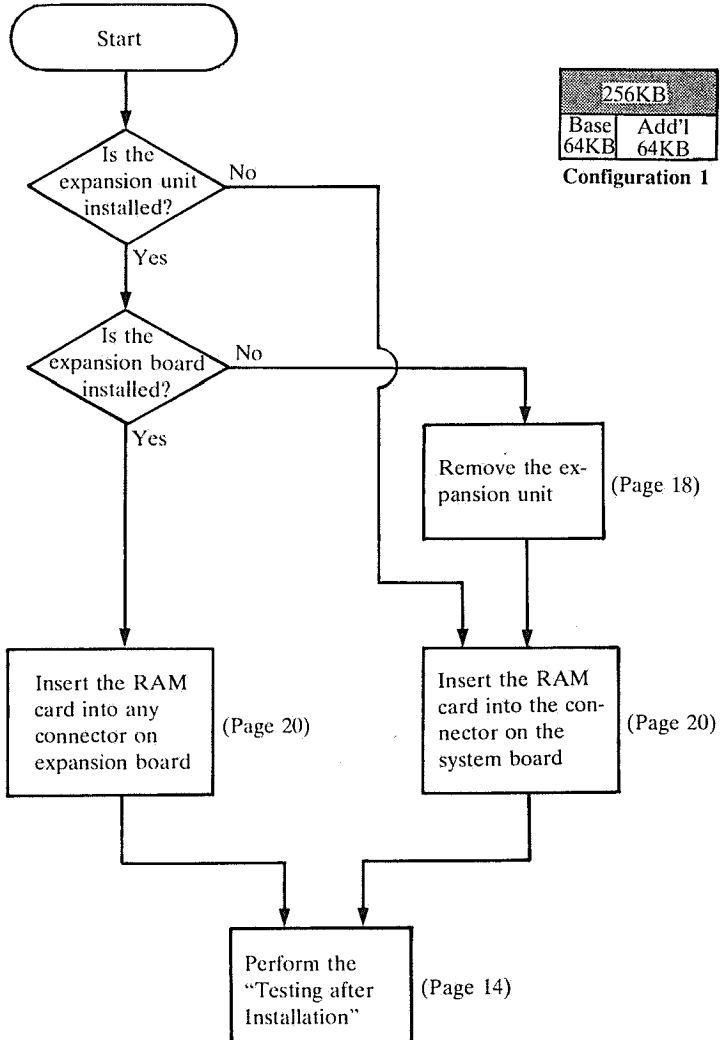

# Installation Procedure for Memory Configuration 2

Proceed according to the flow chart.  
The figures in parentheses indicate the pages to be referred to.

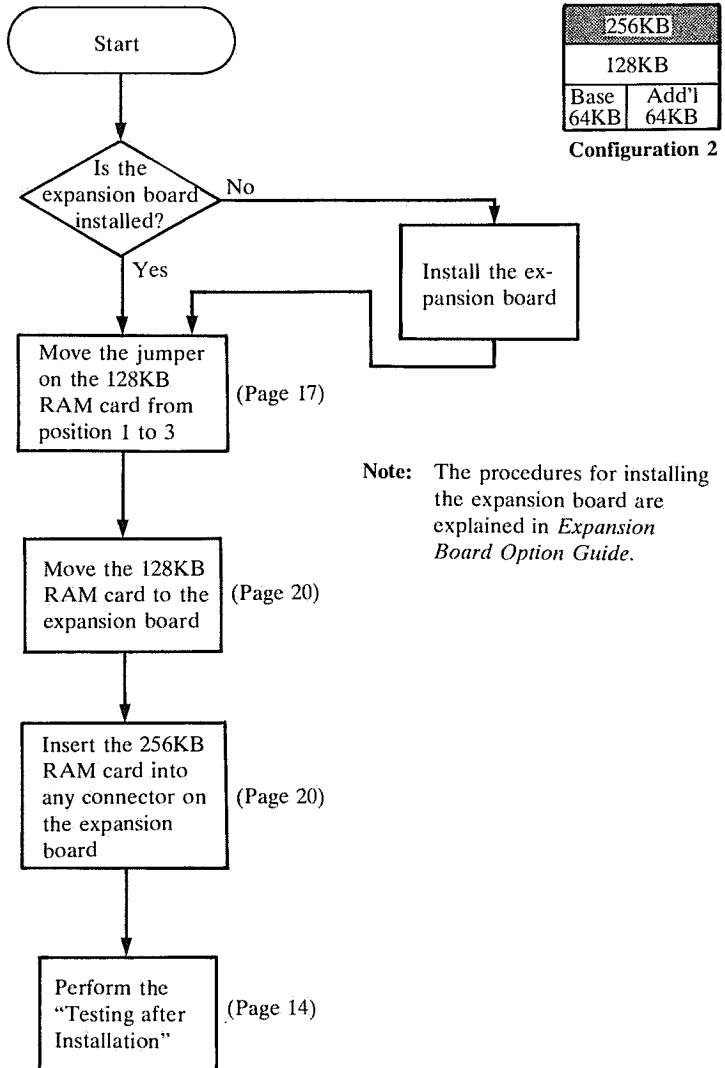

# Installation of the 384KB RAM Card

---

Proceed according to the flow chart.  
The figures in parentheses indicate the page to be referred to.

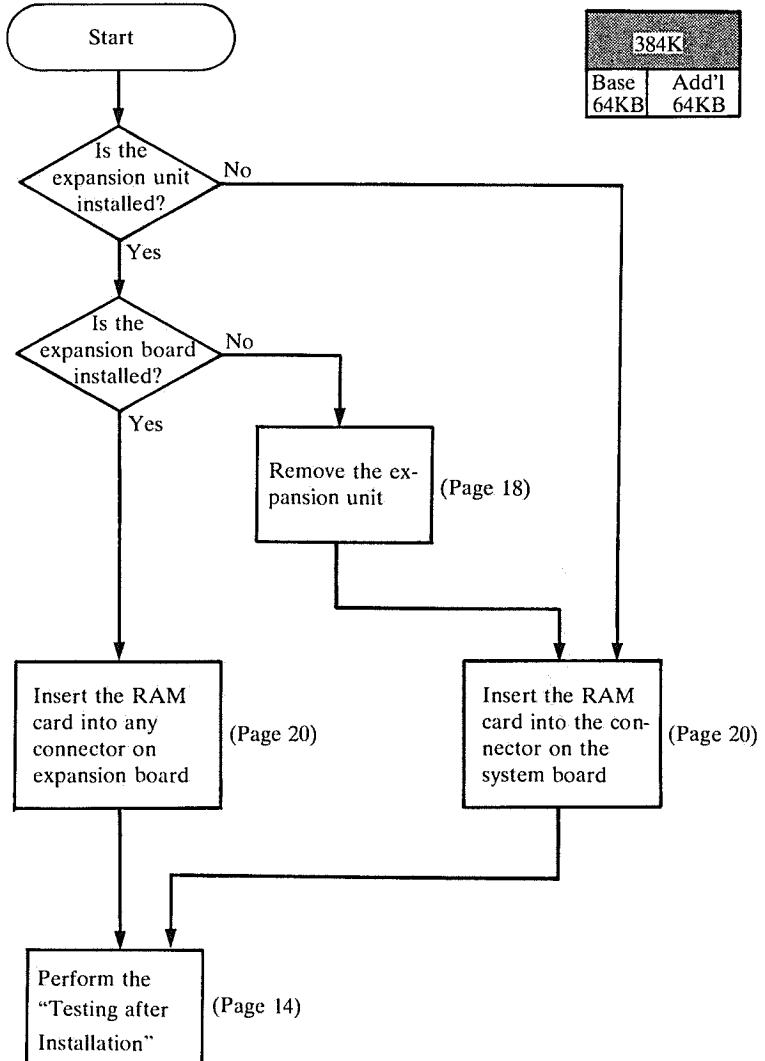

# Testing after Installation

---

After installation of the RAM card, perform the following test to ensure that you have installed it correctly.

When the system unit power is turned on, the JX system performs a self-diagnostic test automatically.

- 1 Make sure that the system unit power plug is inserted in power outlet, then turn the Power on. After a short time, the screen is displayed. Check the display of the available memory.

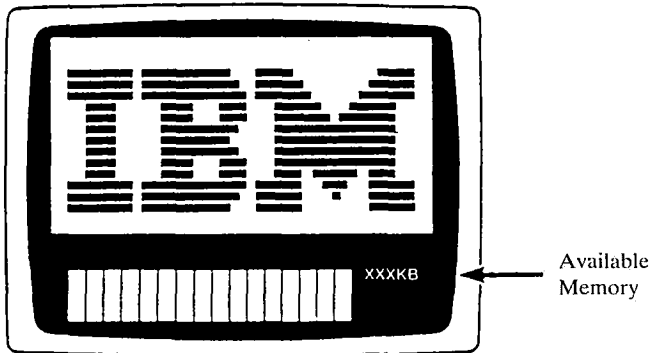

Example of Test Screen

If the value of the available memory is increased by the amount of the installed memory card, the card has been installed correctly.

If the display of the available memory does not increase, or if entirely different characters are displayed, the RAM card or other parts have not been installed correctly. Check the installation procedures again and, if the problem persists, refer to Chapter 7, “Problem Determination Guide,” in *Guide to Operations*.

**Note:** To use memory greater than 128KB with DOS, you must install the memory device driver. Refer to the DOS Reference Manual for instructions.

## Supplementary Information

---

Refer to the following supplementary information, when necessary, during the installation of a RAM card.

Jumper Setting .....	17
How to Remove the Expansion Unit .....	18
How to Install the RAM Card .....	20
Memory Map .....	24
Related Manuals .....	25



# Jumper Setting

---

The 128KB RAM card has a jumper that determines the memory address.

Connect the jumper as specified in the flow chart of the RAM card being installed.

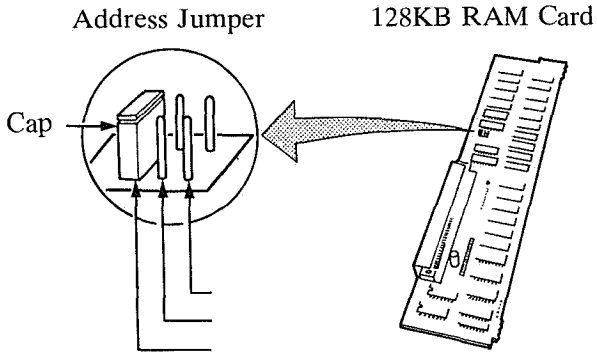

Jumper Position 1

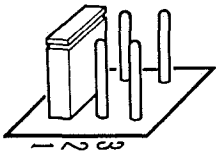

20000H-3FFFFH

Jumper Position 2

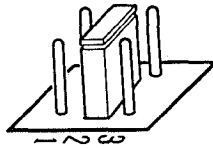

40000H-5FFFFH

Jumper Position 3

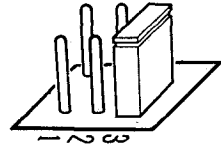

60000H-7FFFFH

# How to Remove the Expansion Unit

---

- 1 Turn the system unit power off and remove the power plug from the power outlet.

Turn the other peripheral devices power off (display, printer, etc.) and remove their power plugs from the power outlets.

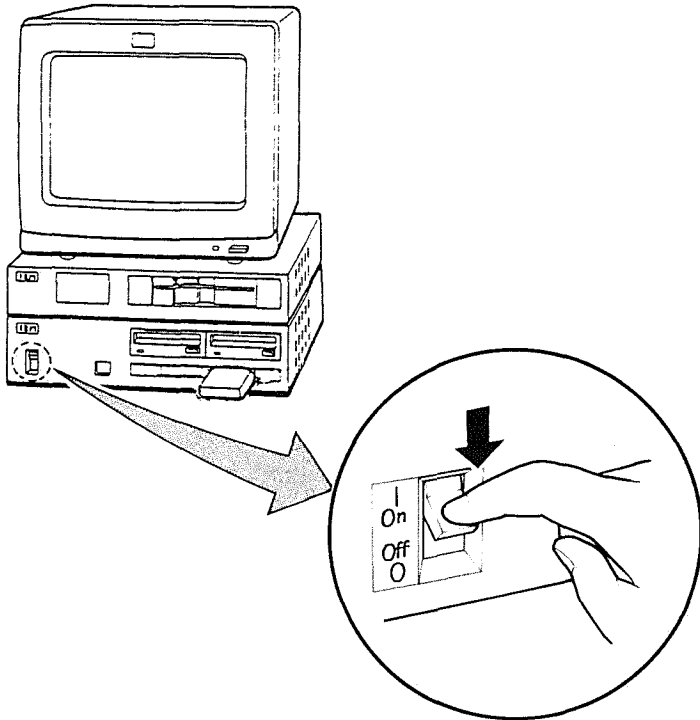

If the expansion unit has a diskette drive, disconnect the signal cable (which comes from the system unit) from the diskette drive and proceed to the next step.

**3** If the expansion unit is installed, disconnect it.

If the expansion unit has an expansion board, disconnect it by referring to the *Expansion Board Option Guide* before performing the following procedures.

- (1) Remove the expansion unit power plug from the system unit. Then, loosen the two screws on the back by turning them to the left with a screw driver. The screws cannot be removed, but they must be loosened completely.

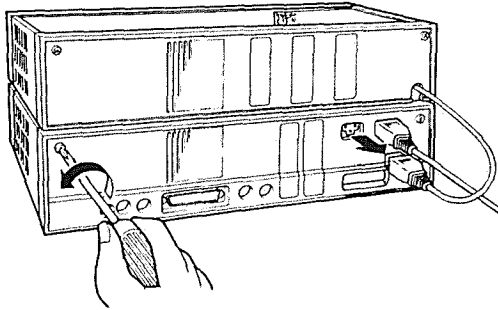

- (2) Carefully lift the expansion unit and remove it by pulling it towards the back.

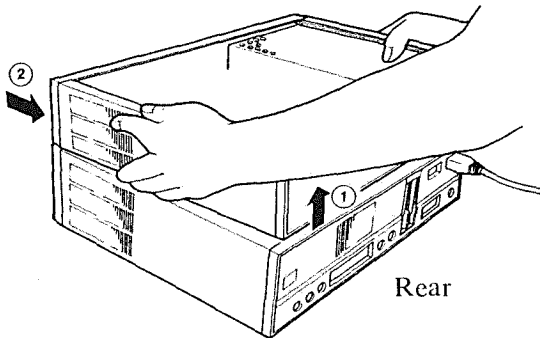

# How to Install the RAM Card

---

The RAM card is installed on the system board or on the expansion board.

- 1 Turn the system unit power off and remove the power plug from the power outlet.

Turn the other peripheral devices power off (display, printer, etc.) and remove their power plugs from the power outlets.

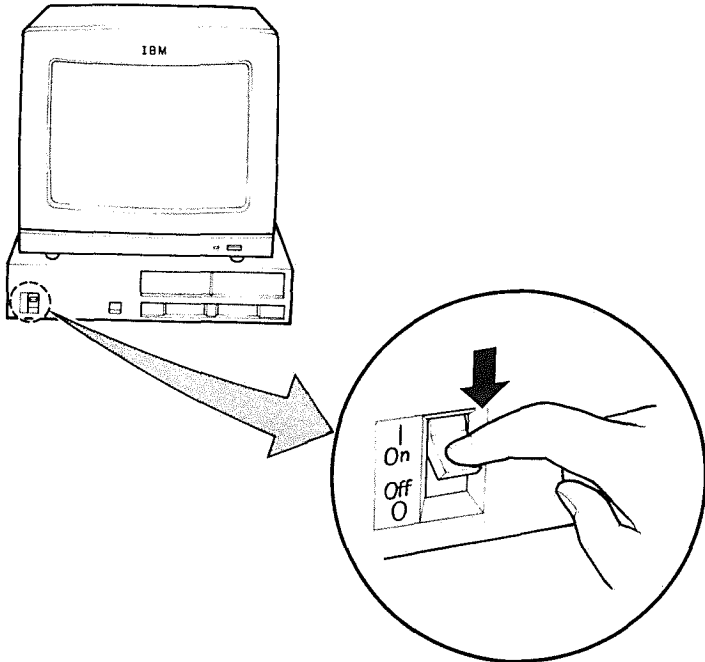

**2** Remove the top cover from the top unit (system unit or expansion unit).

- (1) Loosen the two screws on the back of the unit by turning them to the left with a screw driver. The screws cannot be removed, but they must be loosened completely.

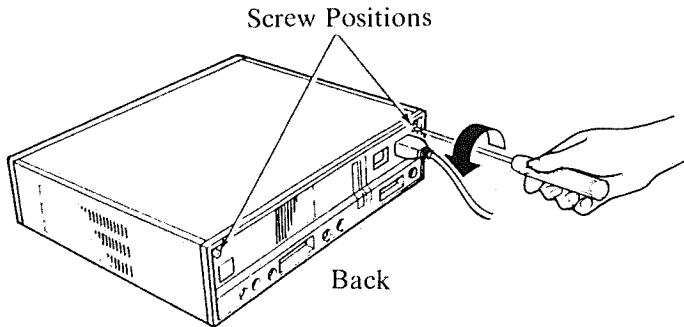

- (2) Insert a coin into the groove on the back of the cover and lift it using a coin as a lever. Remove it by pulling it towards the back.

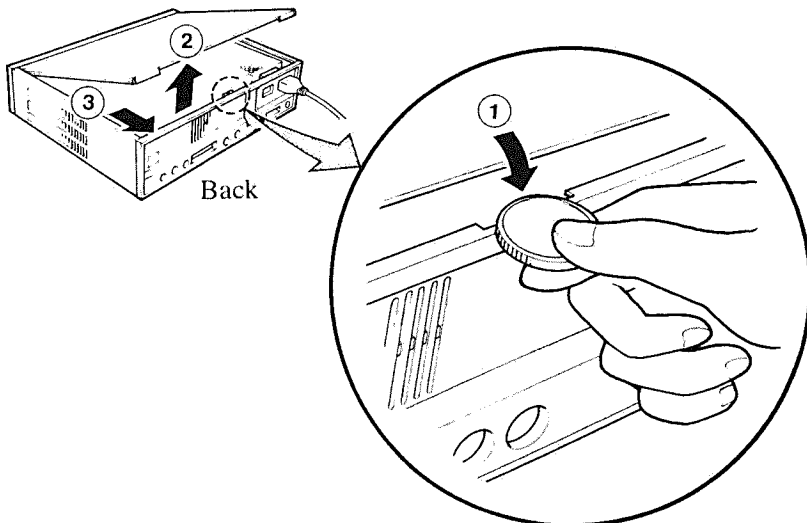

Perform Step 3 to install the RAM card on the system board. Perform Step 4 to install the RAM card on the expansion board.

- 3** Insert the RAM card into the RAM card connector on the system unit.

**Note:** Make sure that the jumper is set correctly.  
(Refer to “Jumper Setting.”)

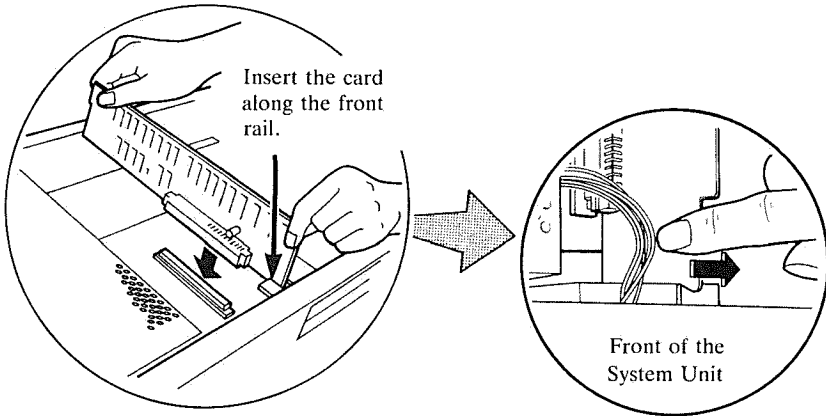

Position the card by pressing it lightly to the right  
(when viewed from the front of the system unit).

Connector Position of the System Unit

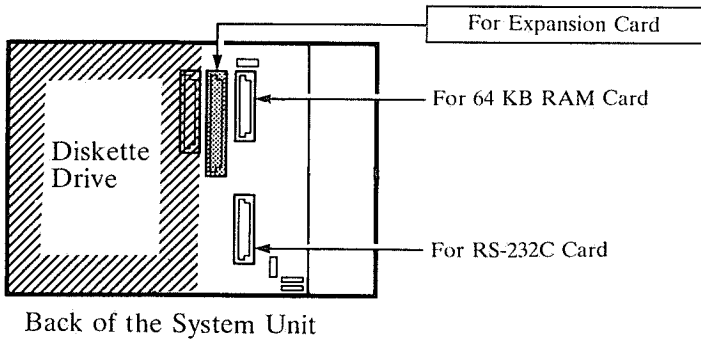

Perform Step 4 to install the RAM card on the expansion board. If you have already installed the RAM card in Step 3, the following operation is unnecessary.

- 4** Attach the RAM card to any connector on the expansion board.

**Note:** Ensure that the jumper is set correctly.  
(Refer to “Jumper Setting.”)

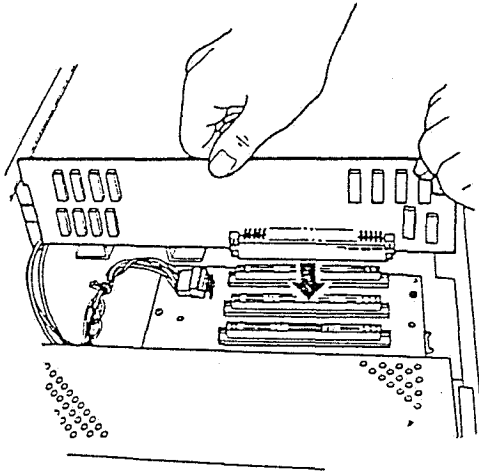

# Memory Map

---

The memory address of the expansion RAM card depends upon the memory configuration of the system.

Memory Configuration	Memory Address								
<table border="1"> <tr><td>128KB</td><td>&gt;</td></tr> <tr><td>Basic + Add'l 64KB</td><td>&gt;</td></tr> </table>	128KB	>	Basic + Add'l 64KB	>	20000-3FFFF 00000-1FFFF				
128KB	>								
Basic + Add'l 64KB	>								
<table border="1"> <tr><td>128KB</td><td>&gt;</td></tr> <tr><td>128KB</td><td>&gt;</td></tr> <tr><td>Basic + Add'l 64KB</td><td>&gt;</td></tr> </table>	128KB	>	128KB	>	Basic + Add'l 64KB	>	40000-5FFFF 20000-3FFFF 00000-1FFFF		
128KB	>								
128KB	>								
Basic + Add'l 64KB	>								
<table border="1"> <tr><td>128KB</td><td>&gt;</td></tr> <tr><td>128KB</td><td>&gt;</td></tr> <tr><td>128KB</td><td>&gt;</td></tr> <tr><td>Basic + Add'l 64KB</td><td>&gt;</td></tr> </table>	128KB	>	128KB	>	128KB	>	Basic + Add'l 64KB	>	60000-7FFFF 40000-5FFFF 20000-3FFFF 00000-1FFFF
128KB	>								
128KB	>								
128KB	>								
Basic + Add'l 64KB	>								
<table border="1"> <tr><td>256KB</td><td>&gt;</td></tr> <tr><td>Basic + Add'l 64KB</td><td>&gt;</td></tr> </table>	256KB	>	Basic + Add'l 64KB	>	20000-5FFFF 00000-1FFFF				
256KB	>								
Basic + Add'l 64KB	>								
<table border="1"> <tr><td>128KB</td><td>&gt;</td></tr> <tr><td>256KB</td><td>&gt;</td></tr> <tr><td>Basic + Add'l 64KB</td><td>&gt;</td></tr> </table>	128KB	>	256KB	>	Basic + Add'l 64KB	>	60000-7FFFF 20000-5FFFF 00000-1FFFF		
128KB	>								
256KB	>								
Basic + Add'l 64KB	>								
<table border="1"> <tr><td>384KB</td><td>&gt;</td></tr> <tr><td>Basic + Add'l 64KB</td><td>&gt;</td></tr> </table>	384KB	>	Basic + Add'l 64KB	>	20000-7FFFF 00000-1FFFF				
384KB	>								
Basic + Add'l 64KB	>								



## Related Manuals

---

- *Guide to Operations*

Basic operations and the problem determination procedures of the IBM-JX.

- *Expansion Board Option Guide*

How to install and remove the expansion unit and how to install the expansion board.











---

Expansion RAM Card Option Guide 115009-0 Printed in Japan





Guide to Operations  
1/5000-0 Printed in Japan

IBM Americans / Far East Corporation