

# DFMS Models S1x, S2x , S4x & S5X

The DFMS models offer exceptional performance and reliability with capacities up to 5.3 GB. The drives spin at 5400 rpm and, with an industry leading areal density, 2.6 GB of storage is packed in a 1 inch high drive and 5.3 GB in a 1.6 inch high drive.

---

## ***APPLICATIONS***

---

- Technical/commercial workstations
- Network servers
- Mass storage arrays
- High end personal computers

---

## ***FEATURES***

---

- 1.32/2.32/2.65/4.32/5.31 GB formatted capacity (at 512 bytes/sector).
- Industry standard interface
  - 50 pin ANSI SCSI-2
  - 68 pin ANSI SCSI-3
  - single ended or differential (50/68 pin)
  - single connector attachment (SCA 80 pin)
- 7.65/12.58 MB/s media data rate. 13 bands.
- Rotational speed 5400 rpm.
- Latency 5.55ms.
- Average read seek time 7.8ms (1.32 and 2.32/2.65 GB)  
8.4ms (4.32/5.31GB)
- Magneto resistive heads.
- PRML data channel (partial response maximum likelihood with digital filter).
- Spindle Synchronization.
- User configurable block sizes.
- 512KB multi-segmented dual port data buffer.
- Drive supported SCSI bus terminator power.
- Industry standard mounting.
- Low command overhead.
- Read ahead caching.
- Write cache support.
- ECC on the fly.
- Predictive failure analysis.

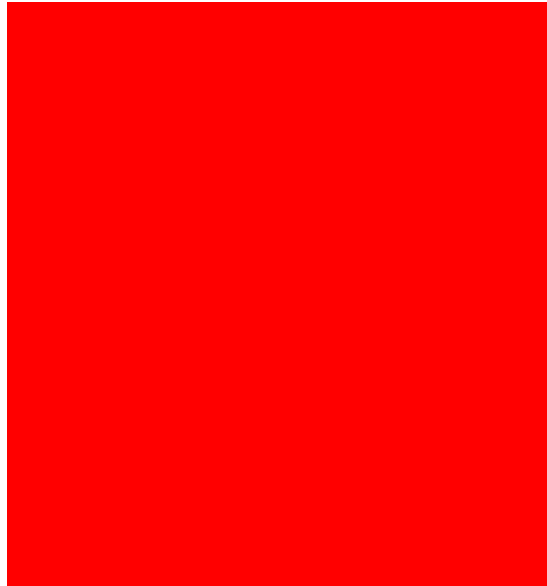

---

## ***BENEFITS***

---

- Popular capacity points.
- Range of SCSI interfaces to suit application
  - High interface data rate
- Exceptionally high data rate across entire disk surface.
- Fast access to data.
- Industry leading areal density 578MB/sq in.
- Robust data channel for improved data integrity.
- Data Server Applications.
- Compatibility with many software systems.
- Fast data retrieval in multi-tasking environments.
- Easy integration across multiple platforms.
- Easy installation.
- Improved data throughput.
- Industry leading reliability.



**WARNING:** This disk drive can be damaged by Electro-Static Discharge. Please follow recommended ESD procedures before unpacking or handling the drive. Ask your IBM marketing representative for details if you need assistance.

## **ELECTRICAL CONNECTOR LOCATIONS**

The electrical connectors are located as shown.

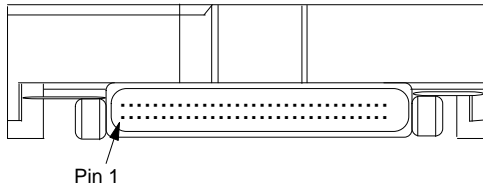

*Electrical Connectors (rear view) 80 Pin SCA models*

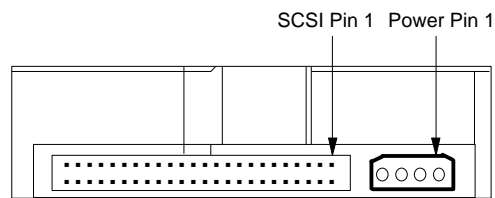
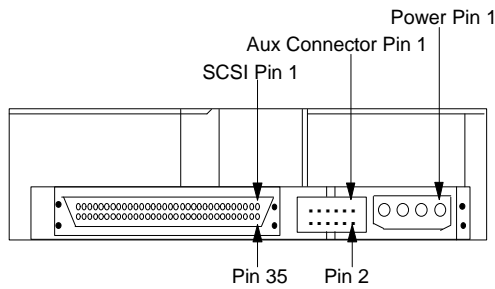

*68 Pin models*

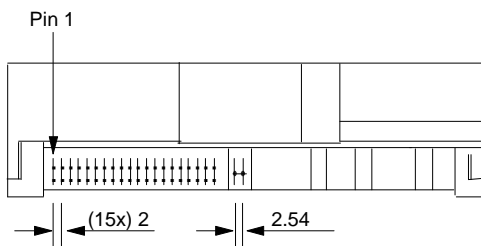

*Connectors (rear view) 50 Pin models*

*Jumper Pin Locations (front view)--all models*

**Note:** See Electrical Interface Specifications section for power pin assignments.

## **OPTION JUMPER BLOCKS**

DFMS models contain a jumper block that can be used to enable certain features and select the SCSI ID of the drive. This jumper block is referred to as the "Front" Option Jumper Block due to its location on the drive (opposite the SCSI connector). This jumper block varies in pin definition based on interface type (50, 68, Differential, SCA).

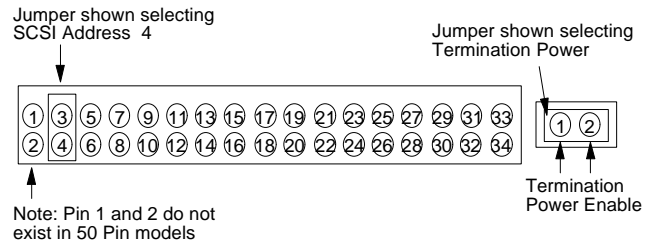

*Electrical Connectors (rear view)*

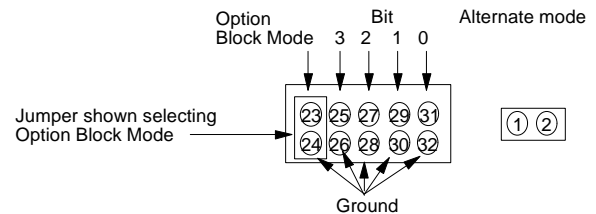

The Option Block connector (2 x 16) used on 50 pin models is an AMP connector (PN 84156-4) having a pin spacing of 2mm.

The Option Block connector (2 x 16) used on the 68 and 80 pin model is an AMP connector (PN 84156-5) having a pin spacing of 2mm.

*Electrical*

### *50/68 Pin Model Single-Ended*

- |                      |                          |
|----------------------|--------------------------|
| 1 SCSI ID 3 (68 pin) | 16 Slave Sync            |
| 3 SCSI ID 2          | 17 External Activity LED |
| 5 SCSI ID 1          | 18 +5V                   |
| 7 SCSI ID 0          | 19 Write Protect         |
| 9 Blank              | 21 Auto Start Delay      |
| 10 Unused            | 23 Optional Block Mode   |

11 Auto Start  
 13 +5V  
 14 Enable Termination  
 15 Master Sync

25 Disable TI Sync  
 27 Disable SCSI Parity  
 29 Disable Unit Attention  
 31 Customizing

*Note:* Pins 2, 4, 6, 8, 12, 20, 22, 24, 26, 28, 30, and 32 are Ground.

*50/68 Pin Model Differential*

1 SCSI ID 3 (68 pin)  
 3 SCSI ID 2  
 5 SCSI ID 1  
 7 SCSI ID 0  
 9 Blank

16 Slave Sync  
 17 External Activity LED  
 18 +5V  
 19 Write Protect  
 21 Auto Start Delay

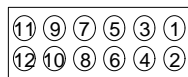
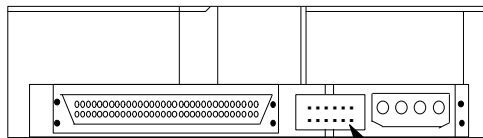

**Optional Block Mode**

11 Auto Start  
 13 +5V  
 14 Unused \*  
 15 Master Sync

25 Disable TI Sync  
 27 Disable SCSI Parity  
 29 Disable Unit Attention  
 31 Customizing

\* Pin 13 is enable narrow mode on 80 pin SCA and 68 pin differential

Pin 14 is ground on 80 pin SCA and 68 pin differential

*Note:* Pins 2, 4, 6, 8, 12, 20, 22, 24, 26, 28, 30, and 32 are Ground.

*68 Pin Auxiliary Connectors*

1 SCSI ID 0  
 2 Unused  
 3 SCSI ID 1  
 4 Auto Spin Start  
 5 SCSI ID 2  
 6 Slave Sync

7 SCSI ID 3  
 8 External Activity LED  
 9 Enable Termination  
 10 Ground  
 11 +5V  
 12 Write Protect

*68 Pin Auxiliary Connector*

The 68 pin models contain an "Auxiliary" connector that replicates some of the functions contained in the Front Option Jumper Block. The Auxiliary connector signal definition conforms to the SCSI document SFF-8009 Rev 2 with the following exceptions:

1  
 0  
 U  
 n  
 u  
 s  
 e  
 d  
 2  
 3

- EXTERNAL FAULT (XTFALT-) is not supported on pin 2.
- AUTO SPIN START was chosen as the "vendor unique" signal assignment (on pin 4). (This signal is an input to the drive. The SCSI spec (SCSI SFF-8009) specifies this pin as an output.) This signal should be useful for those applications that want to "auto-start" the drive based on location dependent SCSI ID.

This pin should be handled in one of the following ways:

- tied to ground (auto spin start enabled)
- allowed to "float" (no connection)
- driven with an open collector driver (> 1 mA sink capability)

Refer to auxiliary connector diagram below.

**SCSI ID (Address) Pins**

*Note:* In the address determination tables "off" means jumper is not in place and "on" means jumper is in place.

Bit3	Bit2	Bit1	Bit0	Address
off	off	off	off	0
off	off	off	on	1
off	off	on	off	2
off	off	on	on	3
off	on	off	off	4
off	on	off	on	5
off	on	on	off	6

off	on	on	on	7	on	off	Yes	10
on	off	off	off	8	on	on	Yes	4
on	off	off	on	9				
on	off	on	off	10				
on	off	on	on	11	<i>Auto-Startup Modes selectable by Auto-Start/Delay Pin Combinations</i>			
on	on	off	off	12				
on	on	off	on	13				
on	on	on	off	14	<i>Pin (80 interface</i>		<i>Drive Behavior</i>	
on	on	on	on	15	<i>pin models)</i>			

*Address Determination--68 and 80 Pin Models*

<i>Auto Start</i>	<i>Auto Start</i>	<i>Auto Startup</i>	<i>Delay(sec)</i>	<i>Delay Multiplier</i>	<i>Mode?</i>
-------------------	-------------------	---------------------	-------------------	-------------------------	--------------

Bit2	Bit1	Bit0	Address				
off	off	off	0	off	off	Yes	0
off	off	on	1	off	on	No	NA
off	on	off	2	on	off	Yes	10
off	on	on	3	on	on	No	NA
on	off	off	4				
on	off	on	5	<i>Auto-Startup Modes selectable by Auto-Start/Delay Pin Combinations.</i>			
on	on	off	6				
on	on	on	7				

*Address Determination of 50 Pin Models*

*Auto Start (& Delay) Pins*

The Auto Start and Auto Start Delay pins control when and how the drive can spin up and come ready. When configured for Auto-Startup, the motor spins up after power is applied without the need of a SCSI Start Unit command. For no Auto-Start, a SCSI Start Unit command is required to make the drive spin and be ready for media access operations. When in Auto-Start mode, the drive will delay its start time by a period of time multiplied by its own SCSI address.

*External Activity (LED) Pins*

The LED pins can be used to drive an external Light Emitting Diode. Please refer to the LED pin section of the DFHS Interface Specification for a detailed functional description of this pin.

Up to 33 mA (plus or minus 5%) of TTL level LED drive capability is provided. Current limiting for the LED is provided on the electronics card. The LED Anode may be tied to the +5V source provided on pin 18 of the Front Option Jumper Block, pin 11 of the Auxiliary connector on the 68 pin Unitized connector or the 5V power source on the 80 pin SCA model. The LED Cathode is then connected to the EXTERNAL ACTIVITY Pin to complete the circuit.

*Pin (50 and 68 interface pin models)*

*Drive Behavior*

<i>Auto Start</i>	<i>Auto Start</i>	<i>Auto Startup</i>	<i>Delay(sec)</i>	<i>Delay Multiplier</i>
off	off	No	NA	
off	on	Yes	0	

**Note:** this set of pins can be used to drive an LED located in a bezel connected to the front end of the drive or to an external LED in systems where the front of the drive cannot be easily seen.

**Note:** 68 pin and 80 pin SCA SCSI models have two sets of pins, a set on the front and a set

on the back, that are connected to the same LED driver circuit. The combined drive capability is stated above.

#### *Write Protect Pin*

If the Write Protect pin is jumpered to ground, the drive will prohibit SCSI commands that alter the customer data area portion of the media from being performed. The state of this pin is monitored on a per command basis. See the DFMS interface specification for functional details.

#### *Option Block Mode Pin*

The Option Block Mode pin is used to modify the function of the Front Option Jumper Block. When the Option Block Mode Pin is not grounded the pin function of the Front Option Jumper Block will be as defined by the upper portion of the referenced figures. When the Option Block Mode Pin is grounded the pins (25, 27, 29, 31) will be redefined to control what is referred to as "Alternate Mode."

"Alternate Mode" allows tailoring of SCSI options such as "boot up" characteristics and other operational features on a per customer basis.

Please contact your IBM Customer Representative for functional details on the customization of function allowed by this mode.

The state of these pins immediately after power is applied to the drive will determine their function.

#### *Disable T.I. Sync Negotiation Pin*

If a Disable Target Initiated Synchronous Negotiation pin is grounded then an Initiator is required to start a negotiation handshake if Synchronous and/or "Wide" (Double Byte) SCSI transfers are desired. Please refer to the DFHS Interface Specification for more details on this feature.

#### *Disable SCSI Parity Pin*

Grounding this pin will disable SCSI Parity checking.

#### *Disable Unit Attention Pin*

Grounding this pin will disable the drive from building Unit Attention Sense information for commands immediately following a Power On Reset (POR) or SCSI Bus Reset. Any pending Unit Attention conditions will also be cleared at POR or SCSI Reset times.

#### *Customizing Pin*

The customizing pin is currently reserved for future use.

#### *Enable Narrow Mode*

Jumpering pin 14 to pin 13 will cause the 68 pin Differential or the 80 pin SCA to operate in a Single Byte mode. The drive will not negotiate for "Wide" (Double Byte) operation. The drive will terminate the unused upper byte and upper byte parity on the SCSI Bus.

#### *Enable Active Termination*

Upon request, Single Ended 50 and 68 pin models are available with on card SCSI bus Active terminators. (Please contact your IBM Customer Representative for the appropriate card PN).

For those cards having the Active Termination feature, this function can be enabled by installing a jumper between pins 13 and 14 of the Front Option Jumper Block or connecting pins 9 and 11 of the Auxiliary Connector on 68 SCSI pin models.

---

## **DATA ORGANIZATION**

---

**Note:** The recording band located nearest the disk outer diameter (OD) is referenced to as "Notch No 1." While the recording band located nearest the inner diameter (ID) is called "Notch No 10." "Average" values are weighted with respect to the number of LBAs per notch when the drive is formatted with 512 byte blocks.

#### *Data Transfer Rates*

Notch	No 1	No 10	Average
-------	------	-------	---------

Buffer to/from media 12.58 7.65 10.87  
 MB/s (instantaneous)  
 Host to/from buffer up to 20.0 MB/s  
 (synchronous) (sustained)  
 Data buffer size (bytes) 512K  
 Rotational speed (RPM) 5402.05  
 Average latency  
 (milliseconds) 5.55  
 Track density (TPI) 4352  
 Min Max

Recording density  
 (BPI) 96,567 124,970  
 Areal density  
 (Megabits/sq in) 420.3 543.9

Model  
 Numbers S5X S4X S3X S2X S1X  
 Disks 8 7 4 4 2  
 User data  
 heads 16 13 8 7 4

(trk/cyl)  
 Seek times  
 (in milliseconds)  
 Single Cylinder  
 (Read) 0.6 0.6 0.6 0.6 0.6  
 (Write) 2.5 2.5 2.5 2.5 2.5

Average (weighted)  
 (Read) 8.4 8.4 7.8 7.8 7.8  
 (Write) 9.9 9.9 9.3 9.3 9.3  
 Full stroke  
 (Read) 16.5 16.5 16.5 16.5 16.5  
 (Write) 19.0 19.0 19.0 19.0 19.0

**Notes:** Times are typical for a drive population under nominal voltages and casting temperature 25 degrees C. Weighted seeks are seeks to the cylinders of random logical block addresses (LBAs).

*Total Cylinders (tcyl) & User Cylinders (ucyl)*

	All models tcyl	S5X ucyl	S4X ucyl	S3X ucyl	S2X ucyl	S1X ucyl
Notch No 1	1183	1170	1169	1168	1167	1165
Notch No 2	200	199	199	199	199	199
Notch No 3	251	250	250	250	250	250
Notch No 4	108	107	107	107	107	107
Notch No 5	373	373	373	373	373	373
Notch No 6	151	150	150	150	150	150
Notch No 7	265	264	264	264	264	264

Notch No 8 228 227 227 227 227 227  
 Notch No 9 176 175 175 175 175 175  
 Notch No 10 246 245 245 245 245 245  
 Notch No 11 52 51 51 51 51 51  
 Notch No 12 929 928 928 928 928 928  
 Notch No 13 253 251 251 251 251 251  
 Sum of all Notches 4416 4392 4389 4388 4387 4385

*Spare Sectors/cylinder*

	S5X	S4X	S3X	S2X	S1X
Notch No 1	53	43	27	23	13
Notch No 2	51	41	25	22	13
Notch No 3	50	40	25	22	12
Notch No 4	49	40	24	21	12
Notch No 5	47	38	24	21	12
Notch No 6	46	37	23	20	11
Notch No 7	44	36	22	19	11
Notch No 8	43	35	21	19	11
Notch No 9	41	34	21	18	10
Notch No 10	40	32	20	17	10
Notch No 11	39	32	20	17	10
Notch No 12	36	29	18	16	9
Notch No 13	31	25	16	14	8

*Last cylinder extra spares ( lcspr)*  
 62 50 32 28 16

*User bytes/sector (ub/sct)*  
 256-744 (even no. of bytes only)

*Sectors/logical block (sct/lba)*  
 1-8

The lowest sct/lba that satisfies the following rules is used...

1. Block length is evenly divisible by a no. 2-8
2. Quotient of previous equation is evenly divisible by 2
3. Quotient must be > or = 256 and < or = 744.

*User bytes/logical block (ub/lba)*  
 256-5952

*Gross sectors per track for several block lengths*  
 Notch Number

User bytes/ logical block	1	2	3	4	5	6	7	8	9	10	11	12	13
256	288	280	270	270	260	240	240	240	240	220	216	180	180
512	180	171	168	165	160	154	150	144	140	135	133	120	105
520	171	168	165	160	154	150	144	140	137	133	132	109	102
522	171	168	163	160	154	150	144	140	137	132	120	108	102
524	171	168	160	160	154	150	144	140	137	132	120	108	102
528	171	168	160	160	154	150	144	140	135	120	120	108	102

688 137 135 130 129 120 120 120 120 109 105 105 87 80  
 744 129 120 120 120 120 120 108 105 102 98 98 80 76

*User capacity for several block lengths*

*S5X Models*

<i>Userbytes/ blocks/ logical bytes</i>	<i>formatted capacity ( bytes)</i>	<i>logical drive</i>
256	4,287,613,696	16,748,491
512	5,318,080,000	10,386,875
520	5,153,496,920	9,910,571
522	5,154,233,742	9,874,011
524	5,167,693,764	9,862,011
528	5,166,743,472	9,785,499
688	5,436,451,472	7,901,819
744	5,484,002,424	7,370,971

*S4X Models*

<i>Userbytes/ blocks/ logical bytes</i>	<i>formatted capacity ( bytes)</i>	<i>logical drive</i>
256	3,484,894,336	13,605,056
512	4,320,075,264	8,437,647
520	4,186,398,840	8,050,767
522	4,186,994,364	8,021,062
524	4,197,927,488	8,011,312
528	4,197,149,088	7,949,146
688	4,416,339,424	6,419,098
744	4,454,988,672	5,987,888

*S3X Models*

<i>Userbytes/ blocks/ logical bytes</i>	<i>formatted capacity ( bytes)</i>	<i>logical drive</i>
256	2,142,450,432	8,368,947
512	2,657,211,904	5,189,867
520	2,574,966,680	4,951,859
522	2,575,328,238	4,933,579
524	2,582,051,396	4,927,579
528	2,581,562,544	4,889,323
688	2,716,242,576	3,948,027
744	2,739,951,864	8,682,731

*S2X Models*

<i>Userbytes/ blocks/ logical bytes</i>	<i>formatted capacity ( bytes)</i>	<i>logical drive</i>
-------------------------------------------------	----------------------------------------	--------------------------

256	1,874,287,104	7,321,434
512	2,324,733,440	4,540,495
520	2,252,796,520	4,332,301
522	2,252,111,732	4,316,306
524	2,258,993,344	4,311,056
528	2,258,563,296	4,277,582
688	2,376,479,968	3,454,186
744	2,396,248,352	3,222,108

*SIX Models*

<i>Userbytes/ blocks/ logical bytes</i>	<i>formatted capacity ( bytes)</i>	<i>logical drive</i>
256	1,070,519,040	4,181,715
512	1,327,857,152	2,593,471
520	1,286,779,000	2,474,575
522	1,286,957,070	2,465,435
524	1,290,315,940	2,462,435
528	1,290,066,096	2,443,307
688	1,357,470,096	1,973,067
744	1,369,343,160	1,840,515

**MODE SELECT OPTIONS**

Certain parameters are alterable using the SCSI "Mode Select" command. This allows certain drive characteristics to be modified to optimize performance on a particular system. Refer to the DFHS SCSI Functional Specification for a detailed definition of Mode Select parameters.

**DC POWER REQUIREMENT LIMITS**

The following voltage specifications apply at the drive power connector. There are no special power on/off sequencing requirements.

+12 Volt Supply

+/- 5.0% (during run)

+5.0% / -7.0% (during spin-up)

+5 Volt Supply

+/- 5.0% (during run and spin-up)

S1x ,S2x, S3x Power Supply Current +5VDC

Notes	Population Mean
Idle average	.690 Amps (* 1)
R/W average	.98 Amps

R/W pulse Base-to-peak .28 Amps  
S4x Power Supply Current +5VDC

S4x Power Supply Current +5VDC

	Notes	Population Mean
Idle average		.720Amps
R/W average		1.01 Amps
R/W pulse	Base-to-peak	.33 Amps

S5x Power Supply Current +5VDC

	Notes	Population Mean
Idle average		.740 Amps
R/W average		.961 Amps(*2)
R/W pulse	Base-to-peak	.392 Amps(*3)

S1x Power Supply Current +12VDC

	Notes	Population Mean
Idle average		0.17 Amps
Seek average	1 op/sec	.0027 Amps
Seek peak		1.2 Amps(*2)
Spin-up	1.5 sec max	1.3 Amps(*3)

S2x and S3x Power Supply Current +12VDC

	Notes	Population Mean
Idle average		.256 Amps
Seek average	1 op/sec	.003 Amps
Seek peak		1.2 Amps(*2)
Spin-up	1.5 sec max	1.8 Amps(*3)

S4x Power Supply Current +12VDC

	Notes	Population Mean
Idle average		0.34 Amps
Seek average	1 op/sec	0.004 Amps
Seek peak		1.2 Amps(*2)
Spin-up	1.5 sec max	1.8 Amps(*3)

S5x Power Supply Current +12VDC

	Notes	Population Mean
Idle average		0.38 Amps
Seek average	1 op/sec	0.051 Amps
Seek peak		1.58 Amps(*2)

Spin-up 1.5 sec max 1.8 Amps(\*3)

*Notes on typical current draws:*

1. 5 Volt current is given with termination power provided by the using system.
2. The idle average and seek peak should be added together to determine the total 12 volt peak current.
3. The current at start is the total 12 volt current required (ie, the motor start current, module current and voice coil retract current).

*Externally generated ripple*

(as seen at drive power connector)

Voltage	Maximum	Notes
+5VDC	150mV peak-to-peak	0-20MHz
+12VDC	150mV peak-to-peak	0-20MHz

During drive start up and seeking, 12 volt ripple is generated by the drive (referred to as dynamic loading). If several drives have their power daisy chained together then the power supply ripple plus other drive's dynamic loading must remain within the regulation tolerance window of +/- 5%. A common drive supply with separate power leads to each drive is a more desirable method of power distribution.

---

**MODELS**

The DFHS disk drive is available in the following capacities:

DFHS-31080	1.0GB
DFHS-32160	2.0GB
DFHS-34320	4.0GB

The DFHS capacities vary as a function of model and user block size. The emerging Industry Standard Capacity points are multiples of 1.08GB (ie, 1.08/2.16/4.32) at a block size of 512 bytes. This and future products will plan to provide capacities that are consistent with this standard.

Users who choose to make full use of the DFHS drive capacity above the standard capacity points may not find equivalent capacity break-points in future products.



<i>SIX</i>	<i>Capacity GB</i>	<i>SCSI Pins/</i>	<i>SCSI Electric</i>
<i>Model #</i>	<i>(at 512 Byte)</i>	<i>Connector Type</i>	<i>Signal</i>
<i>Type S1F</i>		1.32	50
SEF S1W		1.32	68
SEF/W S1E		1.32	68
DF/W S1S		1.32	80
SCA	SEF/W		
<i>S2X</i>			
S2F	2.32	50	SEF
S2W	2.32	68	
SEF/W S2E		2.32	68
DF/W S2S		2.32	80
SCA	SEF/W		
<i>S3X</i>			
S3F	2.65	50	SEF
S3W	2.65	68	
SEF/W S3E		2.65	68
DF/W			
S3S	2.65	80	SCA
SEF/W			
<i>S4X</i>			
S4F	4.32	50	SEF
S4W	4.32	68	
SEF/W			
S4E	4.32	68	DF/W
S4S	4.32	80	SCA
SEF/W			
S5XS5F	5.31	50	SEF
S5W	5.31	68	
SEF/W			
S5E	5.31	68	DF/W
S5S	5.31	80	SCA
SEF/W			

**Note:**

"SEF" stands for Single Ended Fast  
"SEF/W" stands for Single Ended Fast/Wide  
"DF/W" stands for Differential Fast/Wide

**Notes:**

50 pin SCSI connector models offer an 8 bit SCSI bus using the SCSI "A" connector.

68 pin SCSI connector offers an 8/16 bit SCSI bus using the SCSI "P" connector which supports Wide data transfers.

80 pin SCSI connector models offer an 8/16 bit SCSI bus using the SCA connector.

All models support Fast SCSI data transfers.

---

***OPERATING ENVIRONMENT***

---

The drive operates with its performance limits when the following environment is maintained. Product life calculations are based on the nominal environment for a typical application.

*Humidity:*

Operating	5% to 90% noncondensing
Storage	5% to 95% noncondensing
Shipping	5% to 100%

(applies at a packaged level)

*Wet Bulb Temperature:*

Operating / Storage	80 degrees F (26.7 degrees C) maximum
Shipping	85 degrees F (29.4 degrees C) maximum

*Elevation:*

Operating	-1000 to 10,000 feet -304 to 3048 meters)
Shipping/Storage	-1000 to 40,000 feet (-304 to 12,192 meters)

*Temperature:*

Operating ambient	41 to 131 degrees F (5 to 55 degrees C)
Operating casting	41 to 158 degrees F (5 to 60 degrees C)
temperature	
Shipping	-40 to 149 degrees F (-40 to 65 degrees C)
Storage	34 to 149 degrees F (1.1 to 65 degrees C)

*Temperature Gradient:*

Operating	36 degrees F (20 degrees C) per hour
Shipping/Storage	Below condensation

These temperature limits are extremely important and must not be exceeded at the worst case drive and system operating conditions with the drive randomly seeking, reading, and writing.

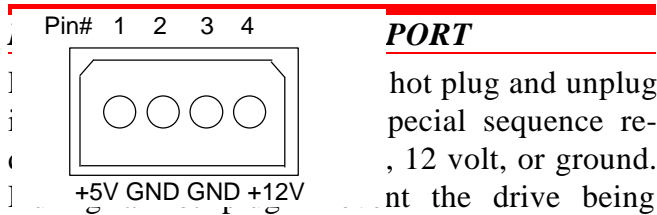

When the drive is plugged in, it will draw a large amount of current at the instant of plug-in. This current spike is due to charging the bypass capacitors on the drive. This current pulse may cause the power supply to go out of regulation. If this supply is shared by other drives then a low voltage power on reset may be initiated on those drives. Therefore the recommendation for hot plugging is to have one supply for each drive. Never daisy chain the power leads if hot plugging is planned. Hot plugging should be minimized to prevent wear on the power connector.

Hot plugging the SCSI bus may cause glitches on the bus. To minimize the chance of glitching, it is recommended to plug in the SCSI bus before the power is applied.

During hot plugging, the supplies must not go over the upper voltage limit. This means that proper ESD protection must be used during the plugging event.

## ***ELECTRICAL INTERFACE SPECIFICATIONS***

### ***Power Connector***

The DC power connector used on all models (50, 68, and 80 pin SCA) are an integral portion of the 50/68 pin SCSI "Unitized" Connectors or the 80 pin "Single Connector Attachment" (SCA) Connector.

### ***Power connector pin assignments***

#### ***SCSI Bus Connector***

DFHS has different model types that support 50 or 68 pin SCSI connectors in either single-ended or differential driver/receiver configurations.

#### ***50 Pin Signal Connector***

50 pin models use an AMP PN 84160-1 connector. The connector is compatible with the ANSI SCSI "A" connector specifications. It is limited to 8 bit data transfers only.

#### ***68 Pin Signal Connector***

58 pin models use an AMP connector (PN 786963-1) that is compatible with the ANSI SCSI "P" connector specifications. It can transfer data in both 8 bit (narrow) and 16 bit (wide) modes.

**Note:** That the "P" connector is not mechanically compatible with the 50-pin "A" connector as defined in the ANSI SCSI-2 standard. Therefore system cables used with 50 pin products cannot be plugged directly into 68 pin models. Despite the difference in connector, the differential 68 pin models are electrically compatible with differential 50 pin models and other 50 pin differential SCSI products and therefore can co-exist on the same bus. In order to do so, the differences in connector types would need to be accounted for in the cable. The same can be said for connecting 68 and 50 pin single-ended models to the same bus. Differential and single-ended models do not work connected to the same bus.

#### ***80 Pin (Single Connector Attachment) Connector***

80 pin SCA models use a Molex connector (PN 87091-0001) that is compatible with the specification of: "Single Connector Attachment for Small SCSI Disk Drives." It can transfer data in both 8 bit (Narrow) and 16 bit (wide) modes.

**Note:** That the "SCA" connector is not mechanically compatible with the 50 pin "A"

connector or the 68 pin "P" connector as defined in the ANSI SCSI standard. This connector is intended for direct backplane attachment and is not intended to be cable attached to the bus.

#### *SCSI Bus Cable*

Single-ended models permit cable lengths of up to 6 meters (19.68 feet). It should be noted however that users who plan to use "Fast" data transfers with single-ended models should follow all of the ANSI SCSI guidelines for single-ended "Fast" operations. This may include a cable length of less than 6 meters.

SCA connector models are not designed for direct cable attachment due to the combination of power and SCSI bus signals. "Fast" data transfers with SCA models should follow all of the ANSI SCSI guidelines for single-ended "Fast" operations.

Differential models permit cable lengths of up to 25 meters (82.02 feet). Cables must meet the requirements for differential cables as set forth in the ANSI SCSI-2 standard under "Cable Requirements--Differential Cable."

The ANSI SCSI standard states that any stub from main cable must not exceed 0.1 meters for single-ended cables and 0.2 meters for differential cables. DFHS has a maximum internal stub length of 0.05 meters on all "single-ended" SCSI signals, and 0.1 meters on all "differential" SCSI signals. To remain compliant with the standard, the SCSI bus cable must not add more than 0.05 meters additional stub length to any of the single-ended SCSI signals or 0.1 meters to any differential SCSI signals.

### **SCSI BUS TERMINATORS (OPTIONAL)**

For those cards having the Active Termination feature, this function can be enabled by installing a jumper between between pins 13 and 14 of the Front Option Jumper Block or connecting pins 9 and 11 of the Auxiliary Connector on 68 SCSI pin models. The using system is

responsible for making sure that all required signals are terminated at both ends of the cable.

80 pin SCA models do not have internal SCSI bus terminators.

Some external terminator possibilities for single-ended cabled systems are listed below:

#### *Single-ended SCSI Terminators*

<i>50 Pin Model Terminators</i>	<i>68 Pin Model Terminators</i>
DM550-06-0	DM5000 68689
DM1050-02-0	DM2050-02-685

Differential models do not have internal SCSI bus terminators. Some terminator possibilities are shown below:

#### *Differential SCSI Terminators*

<i>50 Pin Model Terminators</i>	<i>68 Pin Model Terminators</i>
DM 550-05-0	DM2050-01-68D
DM1050-06-0	
DM5000 686510	

**Note:** A Meritec model 940900-4 or a Data-Mate DM5000-5068-11 can be used to connect the 68 pin connector on a SxW drive for use with a 50 pin connector. The drive will now perform 8 bit transfers.

#### *SCSI Bus Termination Power*

Termination power is optionally provided for systems that desire to use it. In order to use the termination power, the user needs to install a jumper between pins 1 and 2 of the TermPower Block. The jumper should only be installed on one device, which should be the last device on the SCSI bus (ie, the drive that is physically closest to a terminator). 68 pin models can source up to 2.0 Amps of current at 5.0 Volts (plus/minus 5%) for termination power. 50 pin models can source up to 1.5 Amps of current at 5.0 Volts (plus/minus 5%) for termination power.

#### *SCSI Bus Termination Power Short Circuit Protection*

The ANSI SCSI-2 specification recommends for devices that optionally supply TERMPWR, to include current limited protection for accidental short circuits. It also recommends that the maximum current available for TERMPWR should not exceed 5 Amps, UL has a different requirement that they call 8 Amp rule. This rule states that when a power source leaves an enclosure (like SCSI TERMPWR in the SCSI cable), it must trip 8 Amps of current within 1 minute.

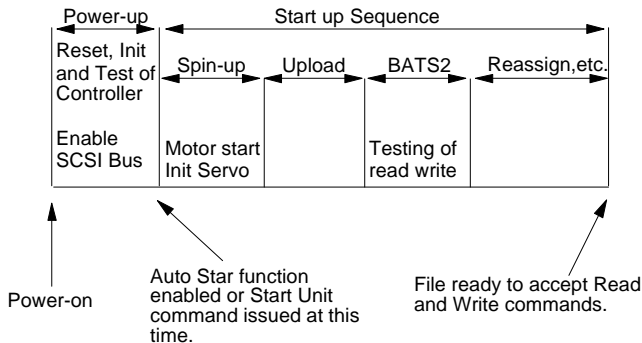

The drive limits current to 5.0 amps through the use of a permanent fuse mounted on the electronics card. Systems may also provide short circuit protection for drive supplied TERMPWR by limiting the current of the 5v power it supplies to the drive.

### **SCSI BUS NOISE REDUCTION RECOMMENDATIONS**

The SCSI committee has spent a large amount of resource looking into what needs to be done to assure SCSI devices will work as specified in the SCSI-2 standard. As a result of this, the committee is recommending the following approach.

- Use regulated 110 ohm termination
- Use AWG 28 polyolefin shielded cables
- Make sure data and parity are on the outer ring of the cable and that REQ and ACK are in the core of the cable

### **START AND STOP TIMES**

<i>Time</i>	<i>Nominal</i>				
Models	S1x	S2x	S3x	S4x	S5x
Power Up	1.5	1.5	1.5	1.5	1.5
Start-up	12.4	14.4	14.4	13.4	13.4
Spin-up	8.2	10.0	10.0	8.7	8.7
Stop Time	4.5	9.0	9.0	6.5	6.5

<i>Time</i>	<i>Maximum</i>				
Models	S1x	S2x	S3x	S4x	S5x
Power Up	2.0	2.0	2.0	2.0	2.0
Start-up	1min	1min	1min	1min	1min
Spin-up	30.8	30.8	30.8	30.8	30.8
Stop Time	12.0	12.0	12.0	12.0	12.0

**Note:** Seconds unless stated.

**Note:** BATS is the abbreviation for Basic Assurance Tests. Start-up sequence spins up the spindle motor, uploads code, performs BATS2 (verifies read/write hardware), resumes "Reassign in Progress" operations, and more. For more information on the start-up sequence, refer to the <O| DFHS |O> Interface Specification.

**Note:** If a RESET is issued before the drive comes ready the power on sequence will start again. In all other cases when a RESET is issued the present state of the motor is not altered.

### **VIBRATION AND SHOCK**

#### *Operating/Nonoperating Vibration*

Due to the complexity of this subject we recommend that users contact the Distributor to discuss how to perform the required measurements if they believe this to be an area which requires evaluation.

**Operating Shock**

The drive will continue to operate, at the stated "Performance" when subjected to a 5G half sine wave shock pulse of 11 milliseconds duration.

No permanent damage will occur to the drive when subjected to a 10G half sine wave shock pulse of 11 milliseconds duration.

The shock pulses are applied in either direction in each of three mutually perpendicular axes, one axis at a time.

**Nonoperating Shock**

No damage will occur if the unpackaged drive is not subjected to a square wave shock greater than a "faired" value of 35 Gs applied for a pe-

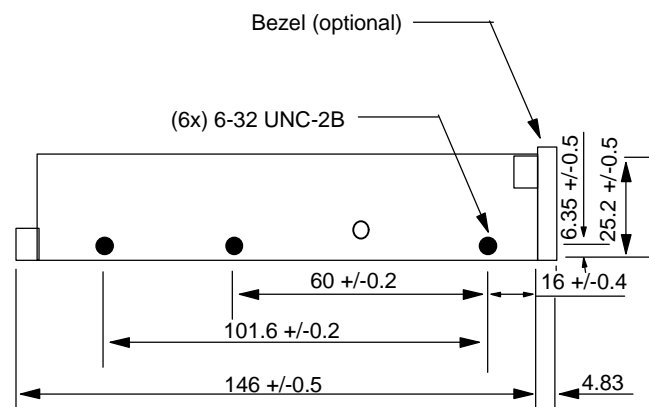

riod of 20 milliseconds, in one direction at a time. Additionally, no damage will occur if the un-

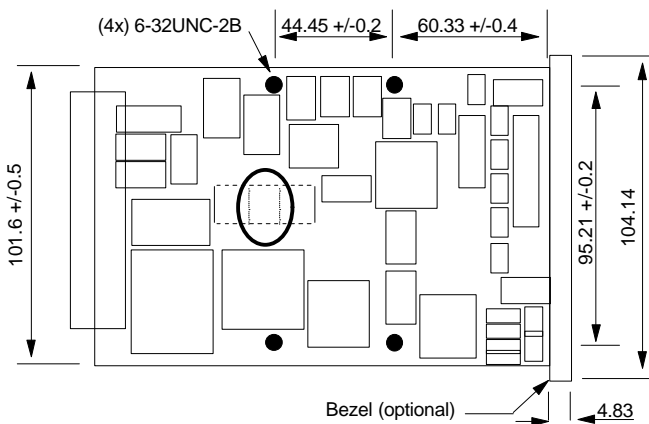

packaged drive is subjected to an 11 millisecond

half-sine wave shock of not greater than 60 Gs applied to all three axes, one axis at a time.

**MECHANICAL SPECIFICATIONS**

This section details the mechanical specifications of the IBM OEM DFHS disk drive. (All versions)

**Weight**

*S1x, S2x, and S3x models*

Approximately 1.0 pounds (0.46 kilograms)

*S4x and S5x models*

Approximately 1.8 pounds (0.82 kilograms)

**Dimensions**

	U.S.	S.I. Metric
Height	1.00 in (S4x 1.63 in)	.4mm(S4x 41.3mm)
Width	4.00 in	101.6mm
Depth	5.75 in	146.0mm

**Clearances**

A minimum of 2mm clearance should be given to the bottom surface except for a 10mm diameter area around the bottom mounting holes. The diagram shows the 2mm clearance requirements (see 1). For proper cooling it is suggested that a clearance of 6mm be provided under the drive and on top of the file.

**Note:** The top of the drive will not exceed the height dimension by more than 2 millimeters during a nonoperating shock.

**Mounting**

The drive can be mounted with any surface facing down.

The drive has both side and bottom mounting holes. Refer to diagrams below for the location of these mounting holes for each configuration.

The maximum allowable penetration of the mounting screws is 3.8mm.

The torque applied to the mounting screws must be 0.8 Newton meters plus/minus 0.1 Newton meters

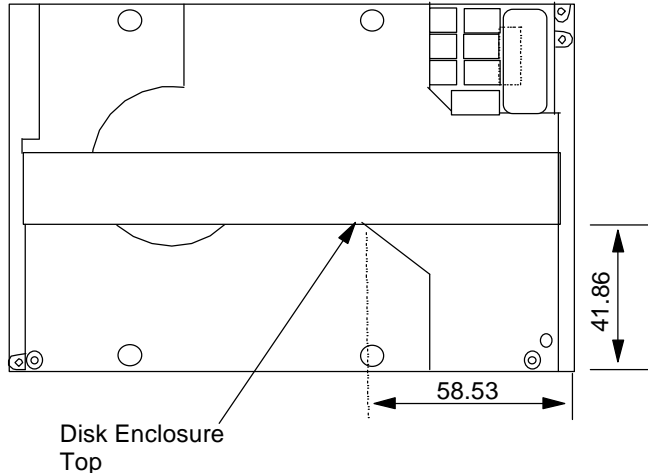

Location of side mounting holes

Bottom View

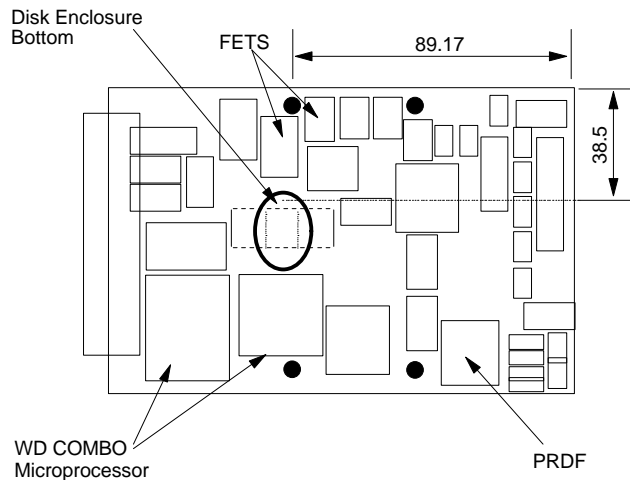

**Grounding Requirements of the Disk Enclosure**

The disk enclosure is at Power Supply ground potential. It is allowable for the user mounting scheme to common the Disk Enclosure to Frame Ground potential or to leave it isolated from Frame Ground.

The drive's mounting frame must be within plus/minus 150 millivolts of the drive's power supply ground. At no time should more than 35 milliamps of current (0 to 100MHz) be injected into the disk enclosure.

The following is a list of measurement points and their temperatures (maximum and reliability). Maximum temperatures must not be exceeded at the worst case drive and system operating conditions with the drive randomly seeking, reading, and writing. Reliability temperatures must not be exceeded at the nominal drive and system operating conditions with the drive randomly seeking, reading, and writing.

	Maximum	Reliability
Disk Enclosure Top	158 F(70 C)	131 F(55 C)
Disk Enclosure Bottom	158 F(70 C)	131 F(55 C)
PRDF Module	203 F(95 C)	176F(80 C)
WD COMBO Module	185 F(86 C)	167F(75 C)
Microprocessor Module	194 F(90 C)	167F(75 C)
VCM FET	194 F(90 C)	167F(75 C)
SMP FET	194 F(90 C)	167F(75 C)

**TEMPERATURE MEASUREMENTS**

Top view

## SPINDLE SYNCHRONIZATION

### Spindle Synchronization Overview

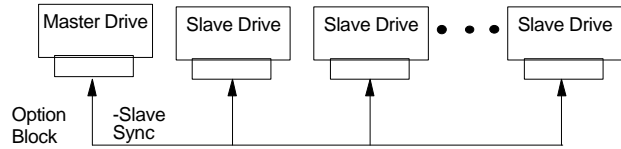

There are four modes of spindle synchronization. See below for a list of how the -MASTER SYNC and -SLAVE SYNC pins on the Option Jumper Block are used for the different modes. The following paragraphs give a short description of each spindle synchronization mode:

-Slave Sync

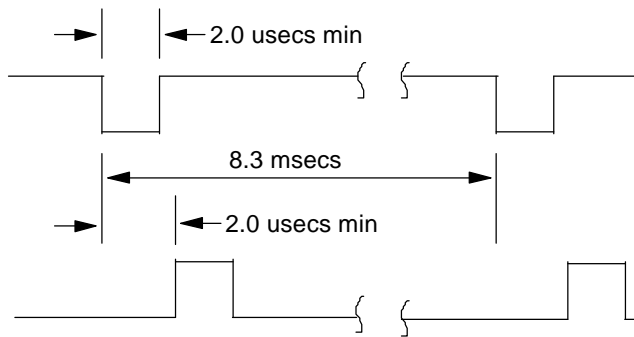

+Slave Index (internal)

*Bottom view*

**Note:** The diagrams above define where measurements should be made to determine the top casting temperature during drive operation and shows the location of the PRDF module. The diagrams above define the modules that are located on the bottom side of the card and the measurement location on the bottom of the casting.

There must be sufficient air flow through the drive so that the casting and module temperature limits defined above are not exceeded.

#### *Module Temperature Measurement Notes*

1. Center on the top surface of the module.
2. If copper tape is used to attach temperature sensors, it should be no larger than 6mm square.

- The Slave drive (Slave Sync mode) receives the index from the Master drive on the -SLAVE SYNC line and synchronizes its INDEX (Slave index) to it.
- Should the drive be the Master drive (Master Sync mode), it outputs its INDEX on the -MASTER SYNC and -SLAVE SYNC lines. The Master drive does not synchronize its Index to any other device. It simply outputs its INDEX.
- In the Master Sync Control mode, a drive will synchronize its spindle to the signal it receives on the -SLAVE SYNC input. It outputs to -MASTER SYNC a pulse that has the same period as the drive INDEX, but is not synchronized to the drive INDEX generated from the disk.
- In the nonsync mode, the drive will receive the -SLAVE SYNC signal, but it is not used by the drive.

## SPINDLE SYNCHRONIZATION CONTROL LINES

MASTER SYNC	SLAVE SYNC	Functional Mode
drive released	drive receive	Slave sync
drive released	drive receive	Master sync
drive released	drive receive	Master sync control
drive released	drive receive	non sync



## *Spindle Synchronization Functional Modes*

ample required the -SLAVE SYNC lines to be daisy chained together.

### *Drive Synchronization with Offset*

The drive electronics receives the Master Index and creates the delayed Slave Index from the drive INDEX. The delay is determined by using the SCSI Mode Select command, Rigid Disk Drive Geometry Parameters. A rotational offset of 0/256 of a revolution up to 255/256 of a revolution may be selected in increments 1/256 of a revolution. Reference the <O> DFHS |O> Interface Specification for further information on the rotational offset of synchronized spindles.



### *SLAVE SYNC*

### *Termination*

Bus termination of the -MASTER SYNC and -SLAVE SYNC signals is internal to the drive. These two signals each have a 2000 ohm pullup to the +5 volt supply. A maximum of 16 drives can have their -MASTER SYNC or -SLAVE SYNC lines daisy chained together. Violating this could damage the Master drive line driver on the MASTER SYNC and/or -SLAVE SYNC line.

It is the using system's responsibility to provide the cable to connect to the -SLAVE SYNC lines, and the -MASTER SYNC lines where needed, of the synchronized drives.

### *Synchronized Time*

The SCSI Mode Select command is used to select the Spindle Sync mode. It could take up to 3.0 seconds (1.5 sec nominally) to synchronize the Slave drive to the Master drive. While the Slave drive is synchronizing to the Master, it will not be able to read and write data. Once synchronized, the drive will maintain plus/minus 20 usec synchronization tolerance.

### *Spindle Synchronization Bus*

The spindle synchronization Bus consists of the two signal lines, MASTER SYNC and -SLAVE SYNC. One potential configuration of this bus for drives that are to be used in a synchronized mode is shown in the following figure. This ex-

### *Bus Characteristics*

- maximum Bus length is 6 meters
- 2 micro-second negative active pulse (when sourced to drive)
- Minimum of 1 micro-second negative active pulse when externally sourced
- 0.8 volts = valid low input
- 2.2 volts = valid high input
- 0.4 volts = low output
- Vcc volts = high output- 60 milli-amps = maximum output low level sink current

The driver used for these two signal lines is a tri-state buffer.



### *SLAVE SYNC Input Timing Requirements*

If the input to -SLAVE SYNC is supplied by an external source other than a <O| DFHS |O> drive, the period of the input signal must be 8.333 msec with a tolerance of +/- .025%.

**PACKAGING:** The drive must be protected against Electro-Static Discharge especially when being handled. The safest way to avoid damage is to put the drive in an anti-static bag before ESD wrist straps etc are removed.

Drives should only be shipped in approved containers, severe damage can be caused to the drive if the packaging does not adequately protect against the shock levels induced when a box is dropped. Consult your IBM marketing representative if you do not have an approved shipping container.

AMP is a trade mark of  
AMP Incorporated.

Molex is a trad mark of  
Molex Incorporated.

DATA MATE is a trade mark of  
Methode Electronics Incorporated.

Western Digital is a trade mark of  
Western Digital Corporation.

NEXT is a trade mark of  
NEXT Corporation.

IBM OEM Europe

PO Box 6

Langstone Road

Havant

Hampshire

PO 9 ISA

United Kingdom

Telephone: (44) 705 486363

This data sheet os mpt a substitute for the full protuct specification, which should be used when detailed information is required.

Product Description data represents IBM's design objectives and is provided for comparative purposes; actual results may vary based on a variety of factors. This product data does not constitute a warrenty. Questions regarding IBM's

warrenty terms or methodology used to derive this data should be referred to your IBM OEM representative. Data subject to change without notice.