



OEM FUNCTIONAL SPECIFICATIONS

for

DVAS-2810 (810MB)

2.5-Inch Hard Disk Drive with SCSI Interface

Rev.(1.0)



OEM FUNCTIONAL SPECIFICATIONS

for

DVAS-2810 (810MB)

2.5-Inch Hard Disk Drive with SCSI Interface

Rev.(1.0)

1st Edition, S85G-6924-00 (SEP 14,1994)

The following paragraph does not apply to the United Kingdom or any country where such provisions are inconsistent with local law: INTERNATIONAL BUSINESS MACHINES CORPORATION PROVIDES THIS PUBLICATION “AS IS” WITHOUT WARRANTY OF ANY KIND, EITHER EXPRESS OR IMPLIED, INCLUDING, BUT NOT LIMITED TO, THE IMPLIED WARRANTIES OF MERCHANTABILITY OR FITNESS FOR A PARTICULAR PURPOSE. Some states do not allow disclaimer or express or implied warranties in certain transactions, therefore, this statement may not apply to You.

This publication could include technical inaccuracies or typographical errors. Changes are periodically made to the information herein; these changes will be incorporated in new editions of the publication. IBM may make improvements and/or changes in the product(s) and/or the program(s) described in this publication at any time.

It is possible that this publication may contain reference to, or information about, IBM products (machines and programs), programming, or services that are not announced in your country. Such references or information must not be construed to mean that IBM intends to announce such IBM products, programming, or services in your country.

Technical information about this product is available from your local IBM representative or at **<http://www.ibm.com/harddrive>**

IBM may have patents or pending patent applications covering subject matter in this document. The furnishing of this document does not give you any license to these patents. You can send license inquiries, in writing, to the IBM Director of Commercial Relations, IBM Corporation, Armonk, NY 10577.

© Copyright International Business Machines Corporation 1994. All rights reserved.

Note to U.S. Government Users —Documentation related to restricted rights —Use, duplication or disclosure is subject to restrictions set forth in GSA ADP Schedule Contract with IBM Corp.

Contents

A. Preface	A-1
A.1 Notices	A-1
A.2 Related Documents	A-1
A.3 Glossary	A-1
1. Product Outline	1-1
2. Drive Characteristics	2-1
2.1 Logical Drive Format	2-1
2.2 Data Sheet	2-1
2.3 Performance Characteristics	2-2
2.3.1 Drive Ready Time	2-2
2.3.2 Command Overhead	2-3
2.3.3 Average Seek Time (Including Settling)	2-4
2.3.4 Single Track Seek Time	2-4
2.3.5 Full Stroke Seek	2-4
2.3.6 Average Latency	2-5
3. Data integrity	3-1
3.1 Equipment Status	3-1
3.2 WRITE Safety	3-1
3.3 Data Buffer Test	3-1
3.4 Error Recovery	3-1
4. Defect Flagging	4-1
4.1 After Erase Unit	4-1
5. Specification	5-1
5.1 Environment	5-1
5.1.1 Temperature and Humidity	5-1
5.2 DC Power Requirements	5-2
5.3 Error Rate	5-3
5.4 Contact Start Stop (CSS)	5-3
5.5 Mean Time To Failure (MTTF)	5-3
5.6 Warranty	5-3
5.7 Useful Life	5-3
5.8 Preventive Maintenance	5-3
5.9 Mechanical Specifications	5-4
5.9.1 Outline	5-4
5.9.2 Mechanical Dimensions	5-5
5.9.3 Hole Locations	5-5
5.9.4 Connector	5-6
5.9.5 Mounting Orientation	5-7
5.9.6 Landing Zone and Lock	5-7
5.10 Vibration and Shock	5-8
5.10.1 Operating Vibration	5-8
5.10.2 Non-Operating Vibrations	5-8
5.10.3 Operating Shock	5-9
5.10.4 Non-Operating Shock	5-9
5.11 Acoustics	5-10
5.11.1 Sound Power Levels	5-10

5.11.2 Sound Power Acceptance Criteria	5-10
5.12 Identification Labels	5-11
5.13 Electromagnetic Compatibility	5-11
5.14 Safety	5-12
5.14.1 Underwriters Lab (UL) Approval	5-12
5.14.2 Canadian Standards Authority (CSA) Approval	5-12
5.14.3 IEC Compliance	5-12
5.14.4 German Safety Mark	5-12
5.14.5 Flammability	5-12
5.14.6 Safe Handling	5-12
5.14.7 Environment	5-12
5.14.8 Secondary Circuit Protection	5-13
5.15 Drive Handling	5-13
6. Electrical Interface Specifications	6-1
6.1 Connector	6-1
6.2 Cabling	6-1
6.3 Signal Termination	6-1
6.4 Driver / Receiver	6-1

Tables

2-1.	Drive Parameter	2-1
2-2.	Data Sheet	2-1
2-3.	Performance Parameter	2-2
2-4.	Drive Ready Time	2-2
2-5.	Operating Modes	2-3
2-6.	Mode Transition Time	2-3
2-7.	Mechanical Positioning Performance	2-4
2-8.	Single Track Seek Time	2-4
2-9.	Full Stroke Seek Time	2-4
2-10.	Latency Time	2-5
5-1.	DC Power Requirement	5-2
5-2.	Physical Dimension	5-5
5-3.	Random Vibration PSD Profile Breakpoints (Operating)	5-8
5-4.	Random Vibration PSD Profile Breakpoints (Non-Operating)	5-8
5-5.	A-weighted Sound Power Levels	5-10

Figures

5-1. Outline of DVAS-2810	5-4
5-2. 40 pin SCSI Connector	5-6

A. Preface

A.1 Notices

This document describes the characteristics of the following IBM 2.5-inch, SCSI interface hard disk drives:

- DVAS-2810 (810MB)

This document defines the hardware functional specifications. For details about the interface specifications, refer to *OEM Interface Specifications for DVAS-2810 (810MB) 2.5-Inch Hard Disk Drive with SCSI Interface*.

A.2 Related Documents

- Interface Specifications
 - *OEM Interface Specifications for DVAS-2810 (810MB) 2.5-Inch Hard Disk Drive with SCSI Interface*. (Document number: S85G-6925)

A.3 Glossary

<i>Word</i>	<i>Meaning</i>
KBPI	1,000 Bit Per Inch
Mbps	1,000,000 Bit per second
MB	1,000,000 bytes
KB	1,000 bytes
Mb/sq.in	1,000,000 bits per square inch
MLC	Machine Level Control
TBD	To be defined

Note:

No-ID, IBM and AT
are trademarks or registered trademarks of International Business Machines Corporation.

1. Product Outline

- 2.5-inch form factor
- 810MB formatted capacity.
- 512 bytes/block
- No-ID physical format
- SCSI-2 Fast interface
- Interface data transfer capability 10MB/sec max
- Interleave factor 1:1
- 64 KB Read Buffer
- Enhanced ECC implementation
 - 128 bit Reed Solomon Code operating 10-bit symbol
 - Multi burst On-The-Fly correction (up to 4 symbols in one block)
- Automatic retry on errors
- Self Diagnostics during Power On
- Power saving modes
- MR (Magneto Resistive) Head technology
- MCC standardized mounting holes and interface connector
- 1.2watt Idle
- 17mm Height
- MTTF 300,000 power on hours
- 1,7 Run Length Limited (RLL) code
- Multi zone recording (8)
- Media data transfer 36 Mb/sec max
- Average seek time 14ms for read
- Closed Loop actuator servo (Embedded)
- Dedicated head landing zone
- Automatic actuator lock
- All axis (6 directions) mounting
- No preventive maintenance

2. Drive Characteristics

This chapter provides the characteristics of the drives.

2.1 Logical Drive Format

The customer usable data capacity is as shown below.

Table 2-1. Drive Parameter	
Descriptions	DVAS-2810
Bytes per Block	512
Total Customer Usable Data Blocks	1,583,568
Total Customer Usable Data Bytes	810 MB

2.2 Data Sheet

Table 2-2. Data Sheet	
Rotational speed [RPM]	3800
Recording density [KBPI]	83(Ave) / 93.1(Max)
Track density [TPI]	5300
Areal density [Mb/sq.in.]	440(Ave) / 493(Max)
Number of zone	8
Number of disks	3
Servo design method	Closed Loop (Embedded)

2.3 Performance Characteristics

The drive performance is characterized by the following parameters:

- Command Overhead
- Mechanical Positioning
 - Seek Time
 - Latency
- Data Transfer Speed
- Buffering Operation

Note: The following specification defines the drive characteristics, not the system throughput which is dependant on the system and the application.

Function	Typical
Power on to ready (Typical)	4.2 [sec]
Command overhead	4 [msec]
Seek time: Read	14 [msec]
Seek time: Write	15 [msec]
Rotational speed	3800 [rpm]
Media transfer rate [Mb/sec]	24.9 - 36.0
Interface transfer rate [MB/sec]	10 max
Read buffer size [KB]	64

The table shows typical values only. The details are as follows.

2.3.1 Drive Ready Time

Condition (Model)	Typical	Max.
Power On to Ready [sec]	4.2	7.5

Ready The condition in which the drive is able to perform a media access command (read, write) immediately.

Power On This includes the time required for the internal self diagnostics.

2.3.1.1 Operating Modes

Table 2-5. Operating Modes	
Operating Mode	Description
Spin-Up	Start up time period from spindle stop or power down.
Seek	Seek operation mode
Write	Write operation mode
Read	Read operation mode
Idle	Spindle motor and servo system are working normally. Other modules except the servo control and the host interface are sleeping. Commands can be received and processed immediately.
Standby	Spindle motor is stopped. All modules except the host interface are sleeping. Commands can be received immediately. Drive is in an interrupt waiting mode with the lowest power dissipation.

Note: After power down or spindle stopped, a head locking mechanism secures the heads in the landing zone.

2.3.1.2 Mode Transition Time

Table 2-6. Mode Transition Time			
From	To	Typical [sec]	Max [sec]
Standby	Idle	4.2	6.2
Idle	Standby	2.2	5.0

2.3.2 Command Overhead

Command overhead is defined as the time required:

- from when the command is received by the drive
- to the start of motion of the actuator.

2.3.3 Average Seek Time (Including Settling)

Table 2-7. Mechanical Positioning Performance		
Command Type	Typical	Max
Read	14 [msec]	16 [msec]
Write	15 [msec]	17 [msec]

The seek time is measured from the start of actuator's motion to the start of a **reliable read or write operation**. Reliable read or write implies that error correction/recovery is not employed to correct for arrival problems. The average seek time is measured as the weighted average of all possible seek combinations.

$$\text{Weighted Average} = \frac{\sum_{n=1}^{\max} (\max + 1 - n) (T_{n.in} + T_{n.out})}{(\max + 1) (\max)}$$

Where:

max = Maximum seek length

n = Seek length (1 to max)

T_{n.in} = Inward measured seek time for an n track seek

T_{n.out} = Outward measured seek time for an n track seek

2.3.4 Single Track Seek Time

Table 2-8. Single Track Seek Time		
Function	Typical	Max.
Read [msec]	4	5.5
Write [msec]	4	6.5

The single track seek time is the average of the 1000 single track seeks.

2.3.5 Full Stroke Seek

Table 2-9. Full Stroke Seek Time		
Function	Typical	Max.
Read [msec]	23	30
Write [msec]	24	31

Full stroke seek is measured as the average of 1000 full stroke seeks.

2.3.6 Average Latency

Table 2-10. Latency Time		
Rotation	Time for a revolution	Average Latency
3800 [RPM]	15.8 [msec]	7.9 [msec]

3. Data integrity

The drive retains recorded information under all non-write operations.

No more than one block is lost by SCSI BUS reset or power down during write operation.

3.1 Equipment Status

Equipment status is available to the host system any time the drive is not ready to read, write, or seek. This status normally exists at power-on time and will be maintained until the following conditions are satisfied.

- Access recalibration/tuning is complete.
- Spindle speed meets requirements for reliable operation.
- Self-check of drive is complete.

Appropriate error status is made available to the host system if any of the following condition occur after the drive has once become ready:

- Spindle speed goes outside of requirements for reliable operation.
- “Write fault” is detected.

3.2 WRITE Safety

The verification of write operation involves a read-back check of the CRC or ECC in conjunction with **write fault** detection circuits. The **write fault** detection circuits reveal conditions where write operation was intended and did not occur properly and the CRC or ECC verification occurred for old information, or cases where data is erroneously erased.

3.3 Data Buffer Test

The data buffer is tested at a power-on-reset and when a drive self-test is requested by the host. The tests consist of write/read hex ‘00’ and hex ‘FF’ pattern for all bit position of the buffers.

3.4 Error Recovery

Errors occurring with the drive are handled by the error recovery procedure.

Errors that are uncorrectable after application of the error recovery procedures are reported to the host system as non-recoverable errors.

4. Defect Flagging

Media defects are remapped to the next available sector during Erase Unit Operation. The mapping from LBA to the physical location is calculated by an internal maintained table.

4.1 After Erase Unit

- Data areas are optimally utilized right after Erase Unit in performance.
- No spare sector is located on each track spread on user data area.

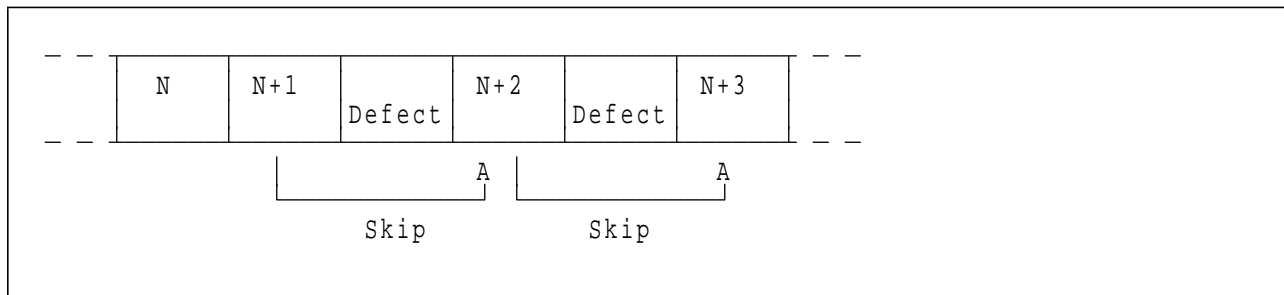

Defects are skipped without any constraint, such as track or cylinder boundary. The calculation from LBA to physical is done by an internal table.

5. Specification

This chapter provides the specifications of the drives.

5.1 Environment

The following table shows the environmental conditions.

5.1.1 Temperature and Humidity

Operating Conditions	
Temperature	5 to 55[°C] (See note)
Relative Humidity	8 to 90 [% RH] non-condensing
Maximum Wet Bulb Temperature	29.4[°C] non-condensing
Maximum Temperature Gradient	20[°C]
Altitude	- 300 to 3000 [m]
Non-Operating Conditions	
Temperature	- 40 to 65[°C]
Relative Humidity	5 to 95 [% RH] non-condensing
Maximum Wet Bulb Temperature	40[°C] non-condensing
Maximum Temperature Gradient	20[°C / Hour]
Altitude	- 300 to 12,000 [m]
Note: The system has to provide sufficient ventilation to maintain a surface temperature below [60°C] at the center of the top cover of the drive.	

5.2 DC Power Requirements

Table 5-1. DC Power Requirement		
Power	Requirement	Note
Nominal supply	+ 5 [V]	
Power supply ripple (0– 20[MHz])	100 [mV p-p max]	1
Tolerance	± 5 %	2
Mode:	Supply Current (Populated Mean) [A RMS]	
Idle (average)	0.24	
Read / write (average)	0.56	
Seek (average)	0.56	
Standby	0.08	
Start up (peak)	0.94	
Start up (average to ready)	0.70	
Supply rise time	7– 100 ms	

Notes:

1. The maximum ripple is measured at input to the drive.
2. The drive does not incur damage by an over-voltage condition of + 25% and the maximum duration is less than 20 [msec].

5.3 Error Rate

- Probability of not recovering data 1 in 10^{13} bits read
- ECC implementation
 - 128-bit Non-interleave Reed Solomon Code operating 10-bit symbol is used to cover the data fields.
 - On-The-Fly correction covers up to four symbols of error in one block.
 - Off-line correction covers up to five symbols of error in one block.

5.4 Contact Start Stop (CSS)

The drive meets the specified error rates after the following start/stop or power on/off cycles in the environment.

- 52,000 cycles under the temperature of 40°C and 15– 20% humidity.
- 10,400 cycles under the temperature of 55°C and 8– 15% humidity.

5.5 Mean Time To Failure (MTTF)

300,000 power-on hours (POH).

Note: Usage assumption for the MTTF is as follows.

- 11 power-on hours per day.
- Drive access rate (seek, write, read) is 20% of power on time.
- Environmental temperature is lower than 40°C.

5.6 Warranty

The warranty will be covered by contracts.

5.7 Useful Life

The useful life of the drive is 5 years minimum.

5.8 Preventive Maintenance

Not required.

5.9 Mechanical Specifications

5.9.1 Outline

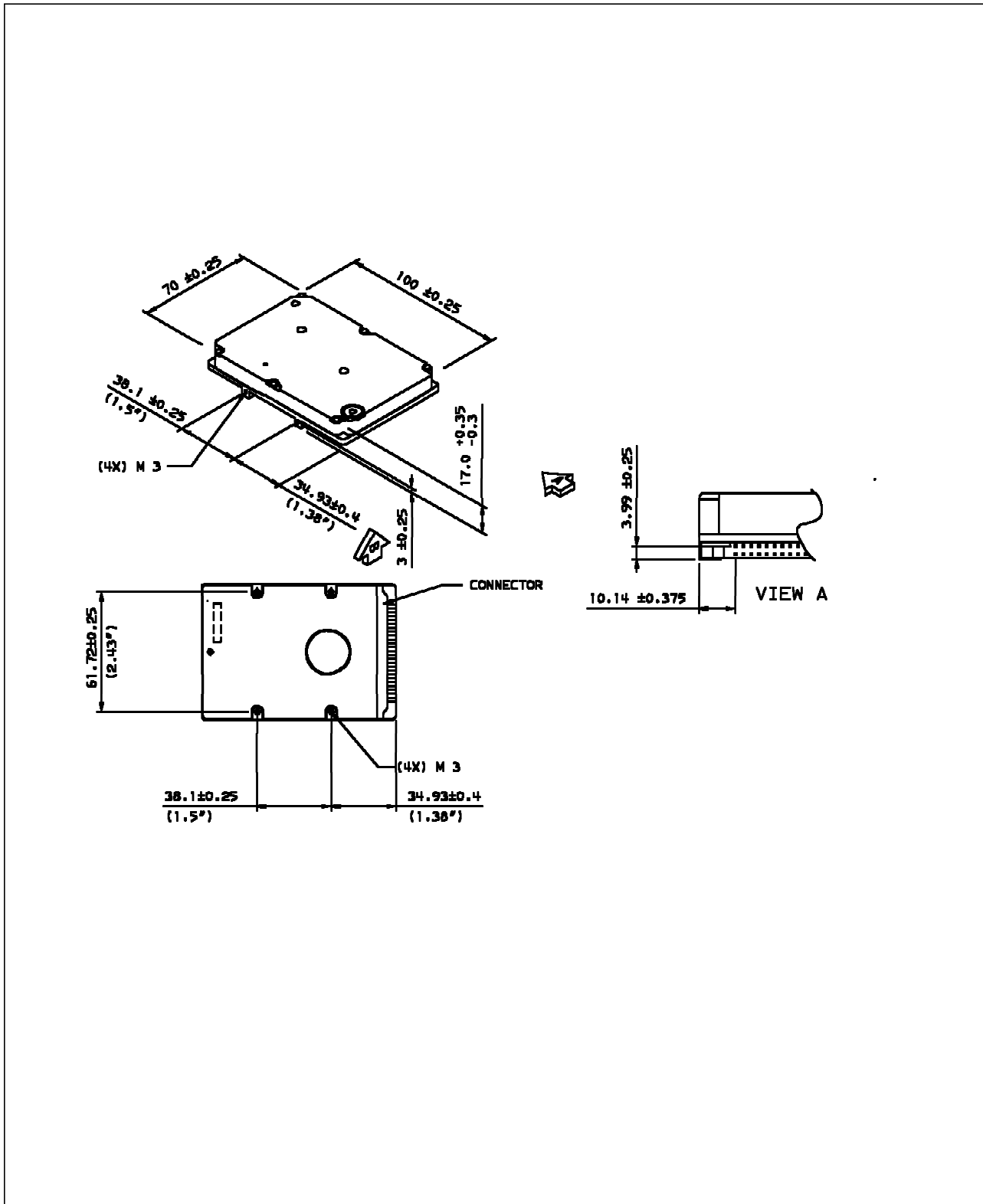

Figure 5-1. Outline of DVAS-2810

5.9.2 Mechanical Dimensions

Table 5-2. Physical Dimension	
Height [mm]	$17.0 + 0.35 - 0.3$
Width [mm]	70.0 ± 0.25
Length [mm]	100.0 ± 0.25
Weight [gram]	180 Max.

5.9.3 Hole Locations

Figure 5-1 on page 5-4 shows the outline of the drive which includes the hole locations. Size and location of the mounting holes comply with MCC.

5.9.4 Connector

The SCSI signal connector is designed to mate with AMP part number 6-176135 or equivalent. Size and location of the mounting holes comply with MCC.

5.9.4.1 Drive Address Setting

The drive recognized its device address with the condition of -ID1, -ID2 and -ID4. The signal condition and the device address are as shown in Figure 5-2.

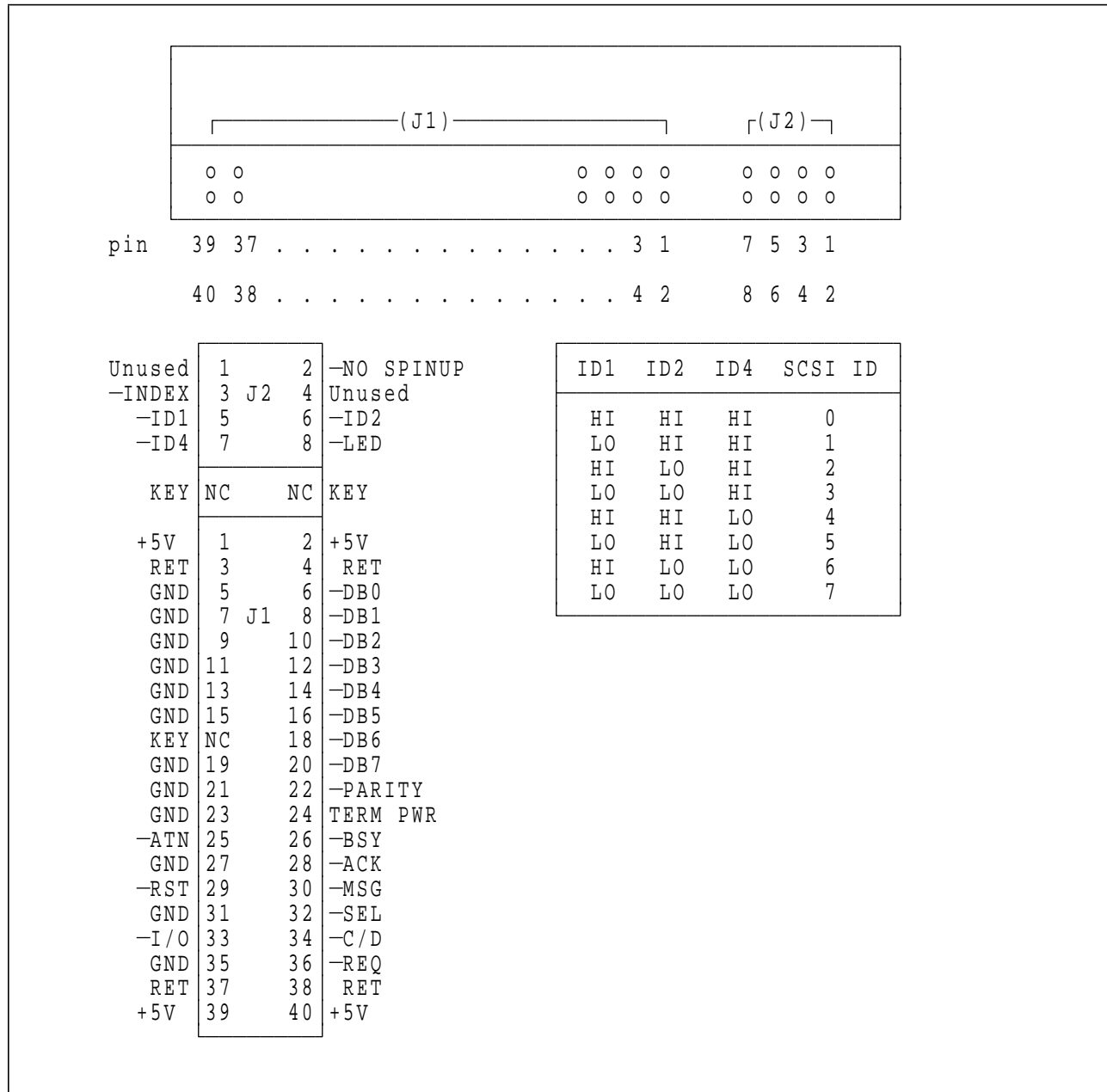

Figure 5-2. 40 pin SCSI Connector

5.9.5 Mounting Orientation

The drive operates in all axes (6 directions). The drive operates within the specified error rates when tilted ± 5 degrees from these positions.

Performance and error rate stay within specification limits even if the drive is operated in other orientations from which it was formatted. Thus a drive formatted in the horizontal orientation operates in the vertical position without any degradation, and vice versa.

The recommended mounting screw torque is 3 ± 0.5 [Kgf.cm].

The recommended mounting screw depth is 3.5 ± 0.5 [mm] for bottom and 5.0 ± 0.5 [mm] for horizontal mounting.

The system is responsible for mounting the drive securely enough to prevent excessive motion or vibration of the drive at seek operation or spindle rotation, using appropriate screws or equivalent mounting hardware.

The vibration test and the shock test are to be conducted with the drive mounted to the table using four bottom screws.

5.9.6 Landing Zone and Lock

A landing zone on the disk, not the data area of the disk, is provided to protect the disk data during shipping, movement, or storage. After power down, a head locking mechanism secures the heads in this zone.

5.10 Vibration and Shock

All vibration and shock measurements in this section are made with the drive that has no mounting attachments for the systems. The input power for the measurements is applied to the normal drive mounting points.

5.10.1 Operating Vibration

The drive operates with no non-recoverable errors while being subjected to the following vibration levels.

The measurements are carried out during 30 minutes of random vibration using the power spectral density (PSD) levels specified in IBM standards as V5L. The vibration test level for V5L is 0.67G (RMS).

Hz	Random Vibration PSD Profile Breakpoints (Operating)								
[Hz]	5	17	45	48	62	65	150	200	500
$\times 10^{-3}$ [G ² /Hz]	0.02	1.1	1.1	8.0	8.0	1.0	1.0	0.5	0.5

Note: The specified levels are measured at the mounting points.

5.10.2 Non-Operating Vibrations

The drive does not sustain permanent damage or loss of recorded data after being subjected to the environment described below.

5.10.2.1 Random Vibration

The test consists of a random vibration applied in each of three mutually perpendicular axes with the time duration of 15 minutes per axis. The PSD levels for the test simulates the shipping and relocation environment which is shown below.

Hz	Random Vibration PSD Profile Breakpoints (Non-Operating)						
Hz	2	4	8	40	55	70	200
[G ² /Hz]	0.001	0.03	0.03	0.003	0.01	0.01	0.001

Overall RMS (Root Mean Square) level of vibration is 1.04G (RMS).

5.10.2.2 Swept Sine Vibration

- 2 G (Zero to peak), 5 to 200 to 5 Hz sine wave
- 0.5 oct/min sweep rate
- 15 minutes dwell at two major resonances

5.10.3 Operating Shock

The drive meets the following criteria.

- No data loss or permanent damages within shock pulses of 20G, 2ms half-sine wave.
- No data loss or permanent damages at Idle, Seek and Read modes within shock pulses of 60G 3.5ms half-sine wave.

The shock pulses of each level are applied to the drive, 10 pulses in each axis and direction for total 60. There must be a minimum of a 3 seconds delay between each shock pulse. The input level is applied to the base plate where the drive is attached with four screws.

5.10.4 Non-Operating Shock

The drive withstands without damage or degradation of performance, a 120G half-sine wave shock pulse of 11 ms duration and a 250G half-sine wave shock pulse of 2ms duration on six sides when heads are parked. (When the power is not applied to the unit, the heads are automatically located on the parked position.)

All shocks are applied in each direction of the drive three mutually perpendicular axes, one axis at a time. Input levels are measured at the frame of the hard disk drive.

5.11 Acoustics

The following shows the acoustic levels.

5.11.1 Sound Power Levels

The upper limit criteria of the A-weighted sound power levels are given in bels relative to one pico watt and are shown in the following table.

Table 5-5. A-weighted Sound Power Levels	
Mode	A-weighted Sound Power Level [Bel]
Idle	4.5
Operating	4.8

Background power levels of the acoustic test chamber for each octave band are to be recorded.

Sound power levels are measured with the drive supported by spacers so that the lower surface of the drive is located 25 ± 3 mm height from the chamber floor. No sound absorbing material shall be used.

The acoustical characteristics of the drive subsystem are measured under the following conditions.

Idle mode:

Powered on, disks spinning, track following, unit ready to receive and respond to control line commands.

Operating mode:

Continuous random cylinder selection and seek operation of actuator with a dwell time at each cylinder. Seek rate for the drive can be calculated as shown below.

Dwell time = $(0.5 + N) \times 60/\text{RPM}$

Seek rate = $1/(\text{Average seek time} + \text{Dwell time})$

Where N = number of maximum data surfaces (N=6 for DVAS-2810)

5.11.2 Sound Power Acceptance Criteria

Statistical upper limit $(L_{\text{Woct}})_{\text{stat}}$ is calculated with the following formula.

$$(L_{\text{Woct}})_{\text{stat}} = (L_{\text{Woct}})_m + k \times (s_t)_{\text{Woct}}$$

where:

$(L_{\text{Woct}})_m$ is the mean value of the sound power level for samples of N drives.

$(s_t)_{\text{Woct}}$ is the total standard deviation for sound power level at each octave band.

$$(s_t)_{\text{Woct}} = \text{SQRT}((s_R)_W^2 + (s_P)_{\text{Woct}}^2)$$

$(s_R)_W$ is the standard deviation of reproducibility for sound power level.

Assume $(s_R)_W = 0.075$ B.

$(s_P)_{\text{Woct}}$ is the standard deviation of the samples for sound power level at each octave band.

k is a coefficient determined by number of samples (N) as shown below.

N	3	4	5	6	7	8	9	10	11	12	13	14	15
k	3.19	2.74	2.74	2.49	2.33	2.22	2.13	2.07	2.01	1.97	1.93	1.90	1.87

The calculated left hand side of the criterion equation above is referred to as LWU and rounded to the nearest 0.05 bel. The individual terms may be rounded to the nearest 0.01 bel before calculation.

5.12 Identification Labels

The following labels are affixed to every drive.

1. A label placed on the top of the HDA contains the statement “Made by IBM” or equivalent, Part number, and MLC number.
2. A bar code label placed on the disk drive is based on user request. The location is to be designated in the drawing.
3. Labels containing the vendor's name, disk drive model number, serial number, place of manufacture and UL/CSA logos.

Except for the bar code, the labels may be integrated.

5.13 Electromagnetic Compatibility

The drive, when installed in the host system and exercised with a random accessing routine at maximum data rate, meets the worldwide EMC requirements listed below.

IBM will provide technical support to meet the requirements to comply with the EMC specifications.

- United States Federal Communications Commission (FCC) Rules and Regulations (Class B), Part 15. IBM Corporate Standard C-S 2-0001-026 (A 6 dB buffer should be maintained on the emission requirements).
- European Economic Community (EEC) directive number 76/889 related to the control of radio frequency interference and the Verband Deutscher Elektrotechniker (VDE) requirements of Germany (GOP). IBM National Bulletin NB 2-0001-400, NB 2-0001-401, and NB 2-0001-403.
- Electrostatic Discharge Susceptibility limits for a Class 2 ESD environment specified in IBM Corporate Standard C-S 2-0001-005.
- Radiated Electromagnetic Susceptibility (RES) as specified in IBM Corporate Standard C-S 2-0001-012.

5.14 Safety

The following shows the safety standards for the different countries.

5.14.1 Underwriters Lab (UL) Approval

DVAS-2810 complies with UL 1950.

5.14.2 Canadian Standards Authority (CSA) Approval

DVAS-2810 complies with CSA C22.2 #950-M89.

5.14.3 IEC Compliance

DVAS-2810 complies with IEC 950.

5.14.4 German Safety Mark

DVAS-2810 was approved by TUV on Test Requirement:
EN 60 950:1988/A1:1990/A2:1991, but GS mark has not been obtained.

5.14.5 Flammability

The printed circuit boards used in this product is made of material with the UL recognized flammability rating of V-1 or better. The flammability rating is marked or etched on the board. All other parts not considered electrical components are made of material with the UL recognized flammability rating of V-1 or better, except minor mechanical parts.

5.14.6 Safe Handling

The products are conditioned for safe handling in regards to sharp edges and corners.

5.14.7 Environment

The product does not contain any known or suspected carcinogens.

Environmental controls meet or exceed all applicable government regulations in the country of origin. Safe chemical usage and manufacturing control are used to protect the environment. An environmental impact assessment has been done on the manufacturing process used to build the drive, the drive itself, and the disposal of the drive at the end of its life.

Production also meets the requirements of the international treaty on chlorofluorocarbon (CFC) control known as the United Nations Environment Program Montreal Protocol, and as ratified by the member nations. Materials to be controlled include CFC-11, CFC-12, CFC-113, CFC-114, CFC-115, Halon 1211, Halon 1301 and Halon 2402. Although not specified by the Protocol, CFC-112 is also controlled. In addition to the above protocol, IBM controls the following:

- All packaging materials used for the shipment of the product do not use controlled CFCs in the manufacturing process.
- All manufacturing processes for parts or assemblies including printed circuit boards, does not use the controlled CFC materials after December 31, 1993.

5.14.8 Secondary Circuit Protection

The drive uses printed circuit wiring that protects the possibility of sustained combustion due to circuit or component failure. Adequate secondary over-current protection is the responsibility of the using system.

The host system must protect the drive from any electrical short circuit problem. 10 [A] limit is required for safety purposes.

5.15 Drive Handling

The drives are packed in ESD protective bags at shipment.

After unpacking, the drives need to be handled carefully to prevent any damage by physical shock and ESD.

Handling only by the sides of the disk enclosure and taking a grounded wrist strap are preferred. The printed circuit board, all electronic components and the interface connector should not be touched.

The drives need to be kept on antistatic pad until integrated into the system.

Pressure onto the top cover should not be applied.

6. Electrical Interface Specifications

6.1 Connector

The SCSI signal connector is designed to mate with AMP part number 6-176135 or equivalent. Figure 5-2 on page 5-6 shows the pin locations on the connector.

6.2 Cabling

The maximum cable length from the host system to the drives is limited to 6 inches with external 1 K-ohm pull up resistors.

In case that appropriate termination resistors are externally equipped to the interface lines, the cable length can be extended. The maximum cable length depends on the condition of various electrical parameters of the interface.

6.3 Signal Termination

The drive has no termination resistor for SCSI interface.

6.4 Driver / Receiver

The drive uses single-ended SCSI Bus drivers and receivers. Termination resistors need to be equipped externally by user.



S85G-6924-00

+++EDF002W LI tag found outside List. (Page 2-3 File: VSC-FS01 SCRIPT)
DSMMOM397I '.EDF#CNTX' WAS IMBEDDED AT LINE 419 OF 'VSC-FS01'
+++EDF011W List end-tag found outside List and ignored. (Page 3-1 File: VSC-FS01 SCRIPT)
DSMMOM397I '.EDFELIST' WAS IMBEDDED AT LINE 547 OF 'VSC-FS01'
+++EDF002W LI tag found outside List. (Page 2-3 File: VSC-FS01 SCRIPT)
DSMMOM397I '.EDF#CNTX' WAS IMBEDDED AT LINE 419 OF 'VSC-FS01'
+++EDF011W List end-tag found outside List and ignored. (Page 3-1 File: VSC-FS01 SCRIPT)
DSMMOM397I '.EDFELIST' WAS IMBEDDED AT LINE 547 OF 'VSC-FS01'