

IBM OEM STORAGE PRODUCTS

WDS 240 & 280

Features

- 43/86 MB formatted capacity (512 bytes/sector)
- Industry standard interface: ANSI/SCSI-2
- Integrated controller
- Logical block address (LBA)
- Implied seeks
- SCSI disconnect and reconnect capability
- Interface odd parity supported
- 1:1 interleave
- 1,7 Run-Length Limited (RLL) encoding
- SCSI data transfer rate: up to 5 MB/sec (synchronous)
- Power Save Option
- Media data transfer rate: 11.1 Mbits/Sec
- 32 KB real look ahead buffer
- Reassignment of new defective sectors without the need for reformat
- Self-diagnostics on power up
- Automatic retry and data correction on read errors
- Closed loop actuator servo (embedded sector servo)
- Rotary voice coil actuator
- Automatic actuator lock
- Dedicated head landing zone
- Average seek time = 18.5 mS (WDS-240)
= 16.5 mS (WDS-280)
- All axis (6 directions) mounting permitted

Performance

	<i>WDS-240</i>	<i>WDS-280</i>
Media Read/Write Data Transfer--Rate in Mbits/Sec	11.1	11.1
Typical Seek (in mS)		
Single Track	5.0	5.0
Average Length	18.5	16.5
Full Length	29.5	29.5
Power ON to Drive Ready	5 Sec (ave)	7.5 Sec (max)
Power OFF to Spindle Stop	5 Sec (max)	

Electrical Interface

Interface Connectors

The drive connector is 2 mm pitch. AMP, DuPont, and Hirose all make suitable mating connectors.

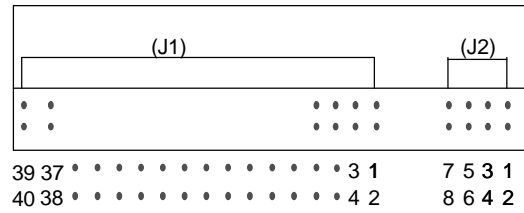

40 pin SCSI Connector and SCSI ID pins

Drive Address (J2)

Pin: 1 unused

2 unused

4 unused

5 addr 0

6 addr 1

7 addr 2

8 LED

To select an address, the appropriate pin(s) must be connected to ground. The illustration below shows which pins to ground to select a particular drive address.

<i>SCSI Address</i>	<i>Addr2</i>	<i>Addr1</i>	<i>Addr 0</i>
0	open	open	open
1	open	open	GND
2	open	GND	open
3	open	GND	GND
4	GND	open	open
5	GND	open	GND
6	GND	GND	open
7	GND	GND	GND

Note:

The LED pin provides a maximum current sink capability of 100mA. The user must attach a current limited resistor in series with this pin and the LED.

The-INDEX pin provides an output signal for reference purposes.

WDS 280/240 drives use single ended SCSI drivers and receivers. Because there are only 40 pins on the SCSI connector, care has to be taken to ensure that correct termination is achieved due to the low number of ground pins.

Two versions of these drives are available, one has no terminators fitted and it is the users' responsibility to provide adequate termination for these devices.

The second version has 1 Kohm pull up resistors fitted and with these drives the system drivers and receivers will also require 1 Kohm pull up resistors to ensure correct termination is achieved. In this case, the maximum cable length for interface is connection between the drive and host system is 150 mm (6 inches).

Drives fitted with 1 Kohm resistors have the following part numbers:

WDS-280 = 95F7193

WDS-240 = 95F7192

Drives with no resistors fitted have the following part numbers:

WDS-280 = 06G6416

WDS-240 = 06G6425

Data Organization

Physical Layout

	<i>WDS-240</i>	<i>WDS-280</i>
Bytes per Sector	512	512
Total Data Sectors	83698	167936
Sectors per Track	38	38
Sectors per Cylinder	75	150
Spare Sectors per Cylinder	1	2
Data Cylinders	1120	1120
Number of data heads	2	4
Number of disks	1	2
Command overhead 2.2 mS (typical)		

DC Power Requirments

Supply Voltage (single supply)	+5 Volts mating	
Voltage Tolerance (incl Ripple)	+/- 250mV	
Ripple (0-20 MHz)	100mV p-p	
Power Consumption (average value in Watts)	<i>WDS-240</i>	<i>WDS-280</i>
Spin-up	3.5	4.4
Seek	2.5	2.6
Write	2.2	2.3
Read	2.2	2.3

Idle	1.3	1.4
Standby	0.3	0.3

Operating Modes

Description

Spin-Up

The time during which the motor is spinning up from a stopped or power down condition.

Seek, Read, Write

Seek, Read, or Write operating modes.

Idle

Spindle motor and servo system working, all modules (except servo control) are "sleeping." Commands can be received and processed immediately.

Standby

Spindle motor is stopped, all modules (except interface) are "sleeping." The drive is waiting for an interrupt and commands can be processed immediately. This is the lowest power dissipation mode.

Mode Transition Time

Standby to Idle 2.5 sec typ 5.0 sec max

Idle to Standby 2.0 sec typ 5.0 sec max

Operating Environment

Humidity

Operating 8% to 90% noncondensing Relative

Nonoperating 5% to 95% noncondensing Relative

Wet Bulb Temperature:

Maximum Wet Bulb:

Operating 29.4 degrees C noncondensing

Nonoperating 35 degrees C noncondensing

Elevation:

Operating Altitude -100 to 3000m

Ship/Storage Altitude -300 to 12000m

Temperature:

Operating 5 to 55 degrees C

Storage -40 to 65 degrees C

Shipping -40 to 65 degrees C

Temperature Gradient 15 degrees C per hour (maximum)

(Operating, Storage, and Shipping)

Air Cooling Requirement

The host system must provide sufficient air flow across the drive to maintain the temperature at less than 60 degrees C (measured at the center of the drives' top cover).

Operating and Nonoperating Vibration

Due to the complexity of this subject we recommend that users contact the Distributor to discuss how to perform the necessary measurements if they believe this to be an area which requires evaluation.

Operating Shock

The Drive will withstand (with no hard error or loss of data) a 10G half-sine wave shock pulse of 11mS duration.

Nonoperating Shock

The Drive will withstand (with no hard error or degradation in performance) a 100G half-sine wave shock pulse of 11mS duration.

Electromagnetic Compatibility

The Drive meets the following EMC requirements when installed in the user system and exercised with a random accessing routine at maximum data rate:

United States Federal Communication Commission (FCC) Rules and Regulations Part 15, Subject J--Computer Devices "Class B Limits."

European Economic Community (EEC) directive #76/889 related to the control of radio frequency interference and the Verband Deutscher Elektrotechniker (VDE) requirements of Germany (GOP).

Signal Definition

The pin assignments of interface signals are listed as follows:

PIN	Signal	PIN	Signal	
01	+5V	02	+5V	
03	RET	04	RET	
05	GND	06	DB0	
07	GND	08	DB1	
09	GND	10	DB2	
11	GND	12	DB3	
13	GND	14	DB4	
15	GND	16	DB5	
17	KEY	18	DB6	
19	GND	20	DB7	
21	GND	22	PARITY	
23	GND	24	TERMPWR	
25	-ATTN	26	-BSY	
27	GND	28	-ACK	
29	-RST	30	-MSG	
31	GND	32	-SEL	
	33	I/O	34	-C/D
	35	GND	36	-REQ

37	RET	38	RET
39	+5V	40	+5V

Mechanical Data

Dimensions	WDS-240	WDS-280
Height	12.7+0.35mm -0.3mm	17.0+0.35mm -0.3mm
Width	70+/-0.25mm	70+/-0.25mm
Depth	100+/-0.25mm	100+/-0.25mm
Weight	140g max	180g max

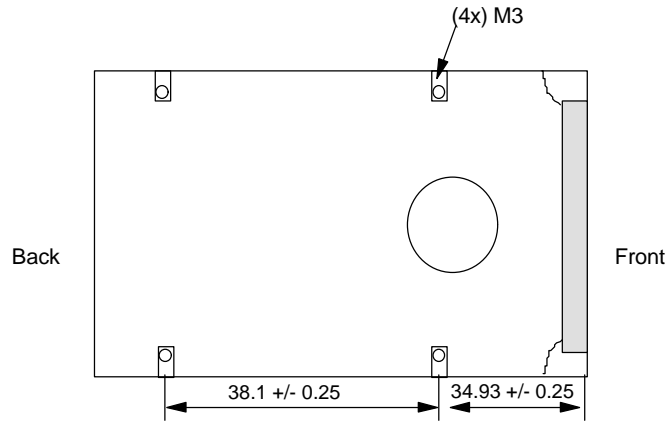
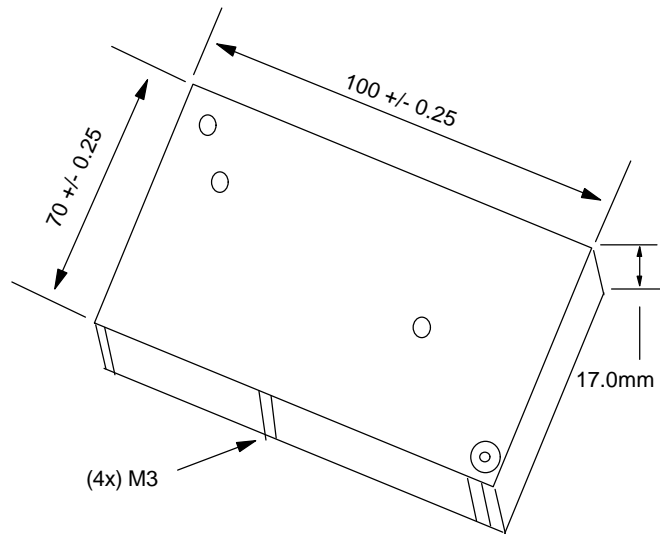

Note: Maximum screw lengths must not be exceeded.

WARNING: This disk drive can be damaged by Electro-Static Discharge, please follow recommended ESD procedures before unpacking or handling the drive. Ask your Dealer for details if you need assistance.

PACKAGING: The drive must be protected against Elektro-Static discharge especially when being handled. The safest way to avoid damage is to put the drive in an anti-static bag before ESD wrist straps, etc, are removed.

Drives should only be shipped in approved containers, severe damage can be caused to the drive if the packaging does not adequately protect against the shock levels induced when a box is dropped. Consult the dealer if you do not have an approved shipping container.

AMP is a trademard of

AMP Incorporated

Molex is a trademark of

Molex Incorporated

DATA MATE is a trademark of

AMP Incorporated

Western Digital is a trademark of the

Western Digital Corporation

NEXT is a trademark of

NEXT Corporation.

IBM OEM Europe

PO Box 6

Langstone Road

Havant

Hampshire

PO9 1SA

United Kingdom

Telephone: (44) 705 486363

This data sheet is not a substitute for the full product specification which should be used when detailed information is required

Product Description data represents IBM's design objectives and is provided for comparative purposes; actual results may vary based on a variety of factors. This product data does not constitute a warrant. Questions regarding IBM's warrant terms or methodology used to derive this data should be referred to your IBM OEM representative. Data subject to change without notice.