



Installing the NETBuilder II[®] Dual Processor Engine Module

For models DPE 40 and DPE *plus*

<http://www.3com.com/>

Part No. 09-0795-001
Published August 1997

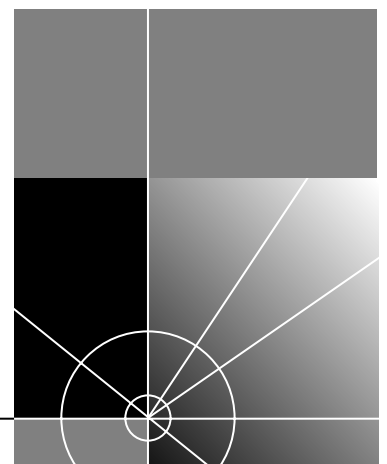

3Com Corporation
5400 Bayfront Plaza
Santa Clara, California
95052-8145

© **3Com Corporation, 1997**. All rights reserved. No part of this documentation may be reproduced in any form or by any means or used to make any derivative work (such as translation, transformation, or adaptation) without permission from 3Com Corporation.

3Com Corporation reserves the right to revise this documentation and to make changes in content from time to time without obligation on the part of 3Com Corporation to provide notification of such revision or change.

3Com Corporation provides this documentation without warranty of any kind, either implied or expressed, including, but not limited to, the implied warranties of merchantability and fitness for a particular purpose. 3Com may make improvements or changes in the product(s) and/or the program(s) described in this documentation at any time.

UNITED STATES GOVERNMENT LEGENDS:

If you are a United States government agency, then this documentation and the software described herein are provided to you subject to the following restricted rights:

For units of the Department of Defense:

Restricted Rights Legend: Use, duplication or disclosure by the Government is subject to restrictions as set forth in subparagraph (c) (1) (ii) for restricted Rights in Technical Data and Computer Software clause at 48 C.F.R. 52.227-7013. 3Com Corporation, 5400 Bayfront Plaza, Santa Clara, California 95052-8145.

For civilian agencies:

Restricted Rights Legend: Use, reproduction or disclosure is subject to restrictions set forth in subparagraph (a) through (d) of the Commercial Computer Software - Restricted Rights Clause at 48 C.F.R. 52.227-19 and the limitations set forth in 3Com Corporation's standard commercial agreement for the software. Unpublished rights reserved under the copyright laws of the United States.

If there is any software on removable media described in this documentation, it is furnished under a license agreement included with the product as a separate document, in the hard copy documentation, or on the removable media in a directory file named LICENSE.TXT. If you are unable to locate a copy, please contact 3Com and a copy will be provided to you.

Unless otherwise indicated, 3Com registered trademarks are registered in the United States and may or may not be registered in other countries.

3Com, NETBuilder, and NETBuilder II are registered trademarks of 3Com Corporation. 3TECH is a trademark of 3Com Corporation. 3ComFacts is a service mark of 3Com Corporation.

AMD is a registered trademark of Advanced Micro Devices. IBM and AT are registered trademarks of International Business Machines Corporation. CompuServe is a registered trademark of CompuServe, Inc.

Other brand and product names may be registered trademarks or trademarks of their respective holders.

Guide written by Ramona Boersma, edited by Pat Vaughn, illustrated by Debra Knodel, and produced by Ramona Boersma.

CONTENTS

ABOUT THIS GUIDE

Conventions 1

1 INSTALLING THE DPE MODULE

DPE Models 1-1

Software and Hardware Support 1-1

Upgrading from a CEC to a DPE 1-1

Before Installing the Module 1-2

Installing in the 4- or 8-Slot Chassis 1-3

Installing in the Extended Chassis 1-4

Connecting a PC, Terminal, or Modem 1-5

Installing Software 1-7

Removing or Installing the Flash Memory Drive Cover 1-8

Where to Go from Here 1-9

2 TROUBLESHOOTING AND REPLACING THE DPE MODULE

Startup Problems 2-1

LED Patterns 2-2

Replacing the DPE Module 2-4

3 FEATURES AND SPECIFICATIONS

Features 3-1

LEDs 3-2

LEDs on the Chassis 3-2

Connectors 3-2

Buttons 3-3

LCD Control Panel 3-3

Physical Specifications 3-3

A UPGRADING MEMORY FOR THE DPE 40

Procedure A-1

B TECHNICAL SUPPORT

Online Technical Services	B-1
World Wide Web Site	B-1
3Com Bulletin Board Service	B-1
Access by Analog Modem	B-2
Access by Digital Modem	B-2
3ComFacts Automated Fax Service	B-2
3ComForum on CompuServe Online Service	B-3
Support from Your Network Supplier	B-3
Support from 3Com	B-4
Returning Products for Repair	B-4

INDEX

3COM CORPORATION LIMITED WARRANTY

ABOUT THIS GUIDE

This guide describes how to install, start up, troubleshoot, and maintain the NETBuilder II® Dual Processor Engine (DPE) module. The DPE module is a central processor for all NETBuilder II systems and comes in two models, the DPE 40 and the DPE *plus*.

This guide is intended for the system administrator, network equipment installer, or network manager who is responsible for installing and managing the network hardware. It assumes a working knowledge of network operations, but does not assume prior knowledge of 3Com® internetworking equipment.





If the information in the release notes shipped with your product differs from the information in this guide, follow the release notes.

Conventions

Table 1 lists conventions that are used throughout this guide.

Table 1 Notice Icons

Icon	Notice Type	Alerts You To...
	Information note	Important features or instructions
	Caution	Risk of personal safety, system damage, or loss of data
	Warning	Risk of severe personal injury



1

INSTALLING THE DPE MODULE

The Dual Processor Engine (DPE) module is the central processor for the NETBuilder II[®] system. It includes a flash memory drive for the system software as well as a second flash memory drive for back-up. Firmware parameters set with the software SysconF command and with the firmware boot monitor are stored on the flash PROM (FPROM). A console port on the front of the module provides local management. The DPE module, in combination with the 800 Mbps backplane, delivers consistently high throughput for all interface ports.

This chapter describes how to install the DPE module into the NETBuilder II system.

If you have a NETBuilder II EZBuilt system with a preinstalled DPE module, go to "Connecting a PC, Terminal, or Modem" on page 1-5.



The software flash memory card does not ship with the stand-alone DPE module and must be purchased separately from 3Com.

DPE Models

The DPE module is available in two models, the DPE 40 and the DPE *plus*.

The DPE 40 has a 50 MHz AMD 29040 RISC processor, 32 MB of instruction and data memory (upgradeable to 64 MB), and 8 MB of shared (packet) memory.

The DPE *plus* has a 62.5 MHz AMD 29040 RISC processor, 64 MB of instruction and data memory, and 16 MB of shared (packet) memory.



The DPE 40 cannot be upgraded to a DPE plus.

Software and Hardware Support

The DPE module needs NETBuilder software version 9.3.1 or later.

The DPE module is compatible with all NETBuilder II chassis.

Upgrading from a CEC to a DPE

The DPE module has two built-in flash memory drives and does not support either the floppy disk drive or the internal flash memory drive. The CEC module uses the internal flash memory drive to boot. Refer to *Upgrading NETBuilder Family Software* for more information about upgrading your software.

When you replace the DPE module, the firmware parameters that were previously configured by the SysconF command in the software are not automatically updated to the FPROM of the replacement DPE module. You must reconfigure these parameters. Refer to the software guide for configuration information.

Before Installing the Module

Before you install the DPE module into the NETBuilder II system, follow these steps:

1 Observe appropriate electrostatic discharge (ESD) precautions.

ESD can damage circuit board components. Failures resulting from ESD may not be covered under your warranty. To prevent ESD damage, follow these procedures:

- Keep the module in its antistatic shielded bag until you are ready to install it.
- Do not touch pins, leads, or solder connections on the board.
- Handle the board by the edges only.
- Store or ship the module in static-protective packaging.

Observe proper grounding techniques when handling the module: Use a foot strap and grounded mat, or wear a grounded static-discharge wrist strap.

2 Unpack and inspect the module for shipping damage.

If you find any damage, file a report with the shipping company. If the module must be returned to your network supplier, ship it in its original shipping carton. If the original carton was damaged in shipment, repack the system in a carton that provides equivalent protection.

3 Write down the serial number and MAC address from the labels on the component side of the module.

You will need this information if you have to contact your network supplier.

Serial number example: S/N:4FTE123456

MAC address example: 08000 21A4B5C

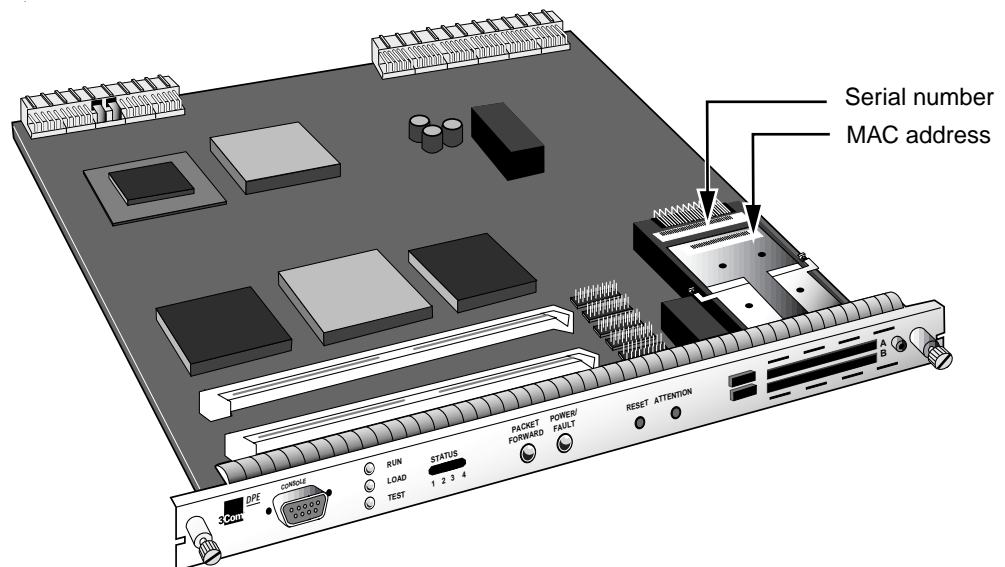

Serial number: _____

Mac address: _____

Installing in the 4- or 8-Slot Chassis

To install the DPE module into the NETBuilder II 4- or 8-Slot chassis, follow these steps. If you own the Extended chassis, refer to the next section.



Although it is not required, 3Com recommends that you turn off the system before you install or remove a DPE module. If you do not turn off the system, the bridge/router will automatically reset when you install the DPE module.

You will need a small, flatblade screwdriver.

- 1 Insert the module into the top slot.



Although the figure shows an 8-Slot chassis, the procedure for the 4-Slot chassis is exactly the same.

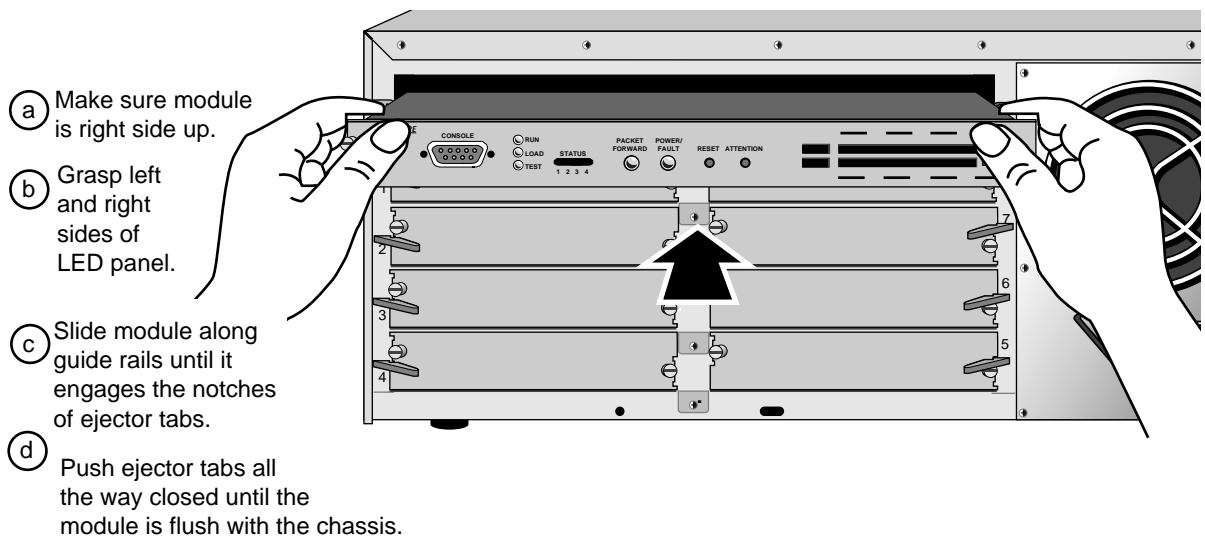

- 2 Hand-tighten the captive screws, then gently tighten them with a small (1/8 in. – 3/16 in.) screwdriver. Do **not** overtighten the screws.

A solid connection of the front panel to the chassis is required for proper operation. Do *not* use the screws to force the board into place.

You are now ready to install the I/O modules. Refer to the appropriate I/O module installation guides. After installing your I/O modules, refer to “Connecting a PC, Terminal, or Modem” on page 1-5.

Installing in the Extended Chassis



Although it is not required, 3Com recommends that you turn off the system before you install or remove a DPE module. If you do not turn off the system, the bridge/router will automatically reset when you install the DPE module.

You will need a small, flatblade screwdriver.

- 1 Insert the module into the left-most slot marked A.

- a Grasp left and right sides of LED panel.
- b Turn the board so the 3Com logo is on the bottom.
- c Slide board along guide rails until it engages ejector tab notches.
- d Push ejector tabs closed until the module is flush with the chassis.

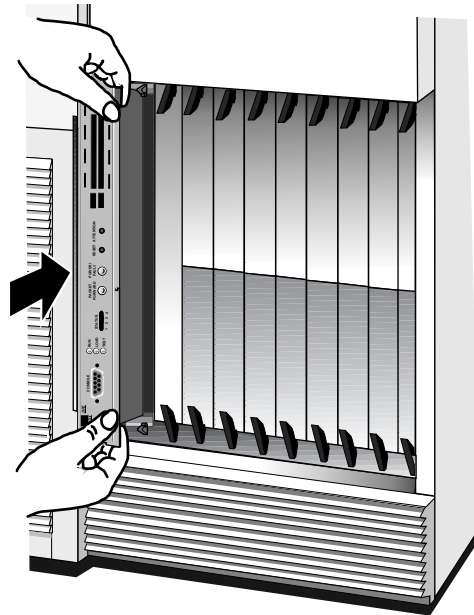

- 2 Hand tighten the captive screws, then gently tighten them with a small (1/8 in. – 3/16 in.) screwdriver. Do **not** overtighten the screws.

A solid connection of the front panel to the chassis is required for proper operation. Do *not* use the screws to force the board into place.

You are now ready to install the I/O modules. Refer to the appropriate I/O module installation guides. After installing your I/O modules, refer to the next section, "Connecting a PC, Terminal, or Modem."

Connecting a PC, Terminal, or Modem

After the I/O modules are installed and cabled according to the I/O module installation guides, connect a PC running a terminal emulation program, a terminal, or a modem to the Console port on the DPE module front panel.

You will use the PC, terminal, or modem to:

- Configure the bridge/router software.
- Use the boot monitor.
- Review startup and system operation messages. Some of the messages displayed by the terminal are more detailed than information displayed on the LCD. These detailed messages may help you troubleshoot startup or operation problems.

To connect a PC, terminal, or modem to the DPE module, follow these steps:

- 1 Obtain a cable to connect the console to the Console port on the DPE module front panel.

Figure 1-1 shows the pinouts for a 9-pin female to 9-pin female PC cable. A null modem-type cable can be used.

Figure 1-2 shows the pinouts for a 9-pin female to 25-pin terminal cable. A null modem-type cable can be used.

Figure 1-3 shows the pinouts for a 9-pin female to 25-pin male modem cable. A straight-through-type cable can be used.



WARNING: To eliminate cable noise emission in excess of FCC Part 15, Subpart J, and EN55022 B, this device cable should be shielded and have connectors with metallic backshells.

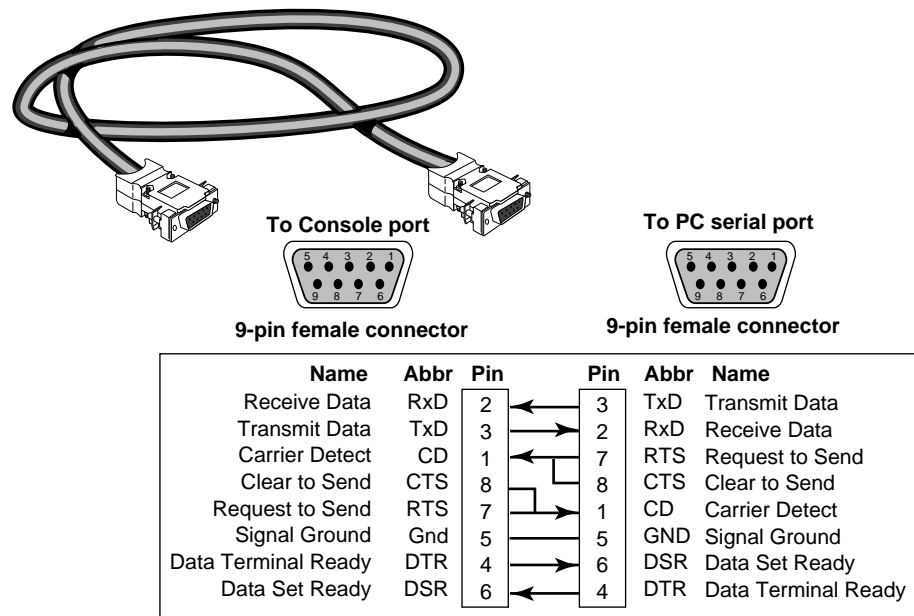

Figure 1-1 9-pin to 9-pin PC Cable (Null Modem-Type)

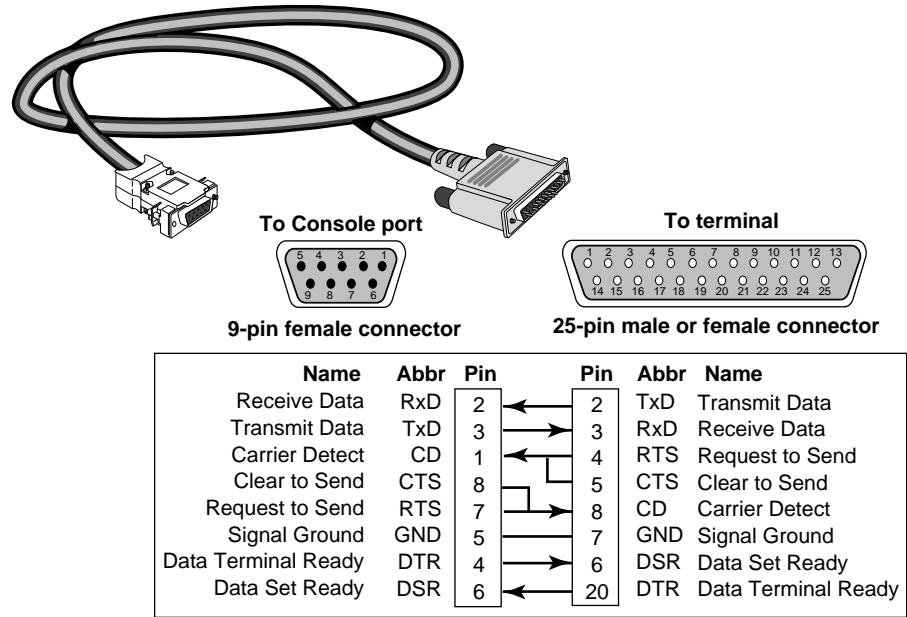

Figure 1-2 9-pin to 25-pin Terminal Cable (Null Modem-Type)

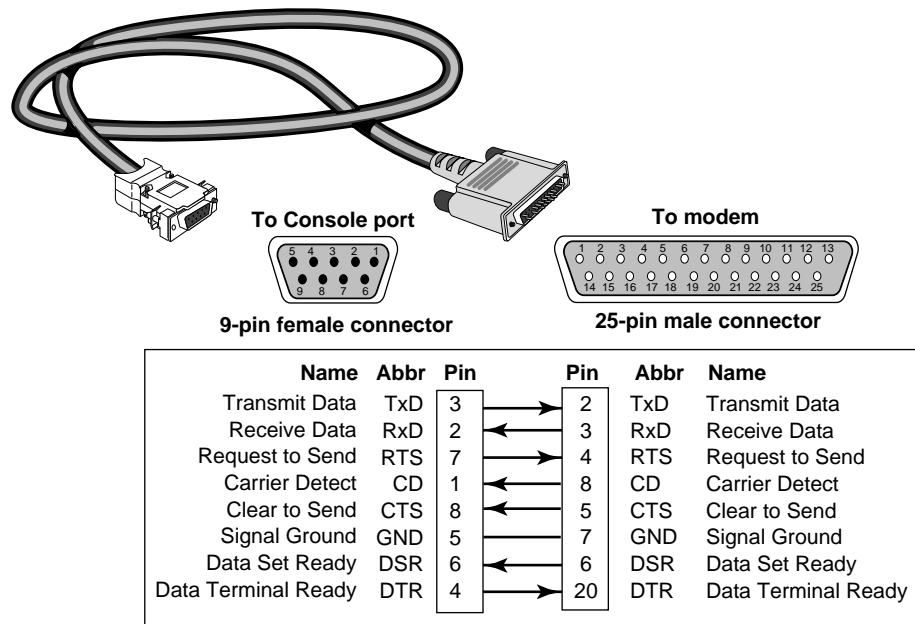

Figure 1-3 9-pin to 25-pin Modem Cable (Straight-Through-Type)

- 2 Connect one end of the cable to the Console port on the DPE front panel and the other end to the serial port on the back of your console.

- 3 Verify that configurable parameters of your console match the configuration settings of the Console port specified in Table 1-1.

Table 1-1 Console Port Configuration Settings

Characteristic	Setting
Baud rate	9600
Databits	8
Parity	None
Stop bits	1
DTR	Ignored
Duplex	Full
Echo	Off
Flow control	X-on/X-off

- 4 Turn on the console.

Installing Software

If you have the software from 3Com preinstalled on a flash memory card, remove the flash memory drive cover if present and insert the card into drive A, the top flash memory drive. The default boot and configuration file paths are set to a directory on drive A.

See the next section to remove and reinstall the flash memory drive cover.

Removing or Installing the Flash Memory Drive Cover

You must install the flash memory drive cover to ensure emissions compliance.

To install a flash memory card, remove the cover as shown:

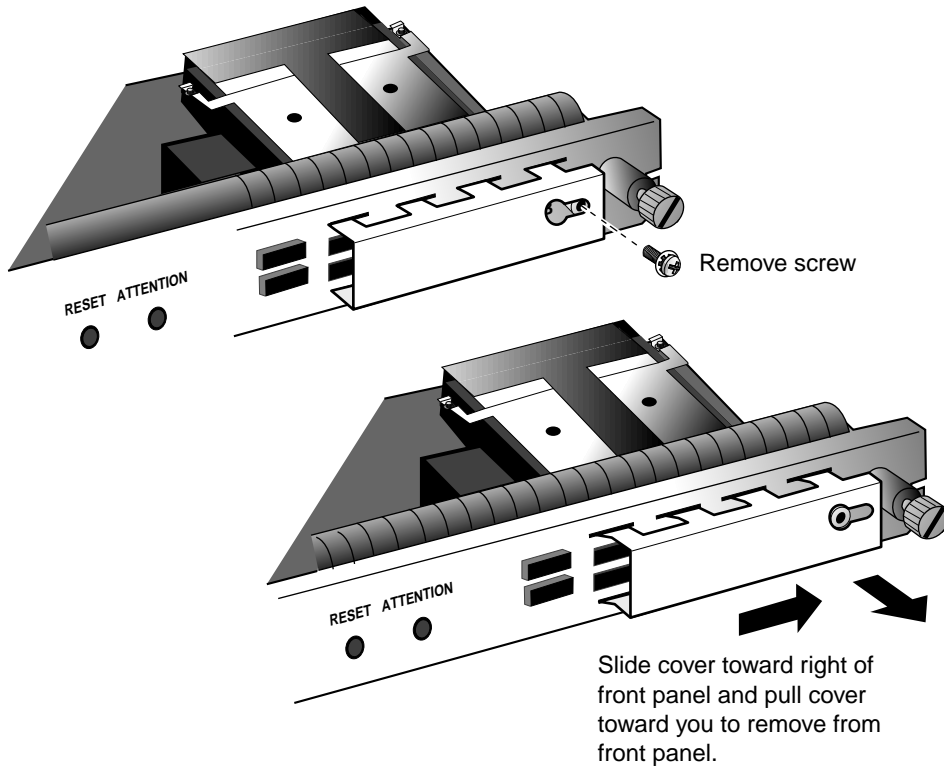

After installing the flash memory card, attach the cover as shown:

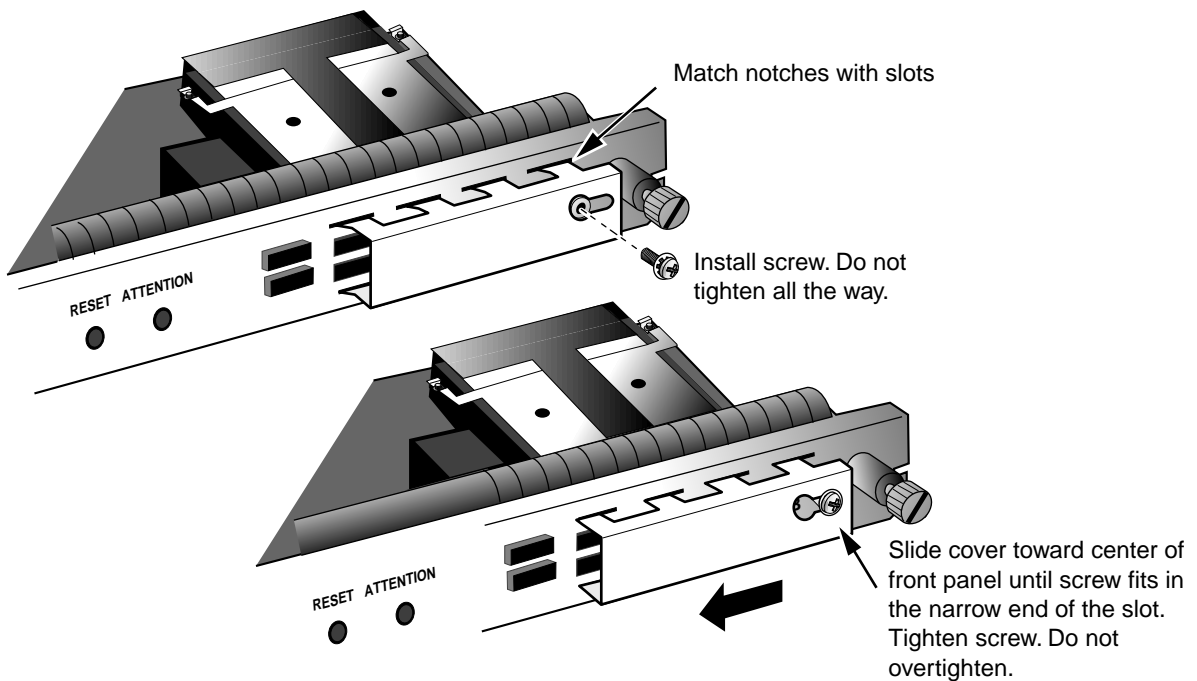

Where to Go from Here

To configure the NETBuilder II software, refer to the software guides that shipped with your software package. Information about the firmware Boot Monitor utility is in *Reference for NETBuilder Family Software*.

Refer to the release notes for approved vendors of blank flash memory cards for backup. *New Installation for NETBuilder II Software* describes how to format a blank card.

2

TROUBLESHOOTING AND REPLACING THE DPE MODULE

This chapter provides information on troubleshooting and replacing the DPE module.

Startup Problems

Table 2-1 lists symptoms of DPE module startup problems (abnormal LED patterns and error messages).

Table 2-1 Troubleshooting the DPE Module

Symptom	Cause and Action
LEDs fail to light at initial power-on or during a reset.	<p><i>No power to the system or the DPE module connectors are not properly mated with the backplane connectors.</i></p> <ol style="list-style-type: none">1 Turn off the NETBuilder II system.2 Verify that the power cord is plugged properly into the system's power supply module and into a working outlet.3 Inspect the system's in-line power fuse and replace it, if necessary. Use the appropriate procedure in <i>Installing the NETBuilder II Bridge/Router</i>.4 Turn on the system.5 If the LEDs still do not light, remove and reinstall the DPE module.6 If the LEDs still fail to light, contact your network supplier.
LCD and terminal displays freeze and nothing happens when either the Enter or Return key is pressed.	<p>Reset the system by pressing the two outer buttons on the LCD control panel.</p> <p>If this does not resolve the problem, call your network supplier.</p>

LED Patterns

The nine LEDs display the diagnostic and operational activity of the NETBuilder II bridge/router. Table 2-2 describes the LEDs during normal operation. Table 2-3 describes the LEDs during an error condition.

Table 2-2 Normal Operation of LEDs

Run	Load	Test	Status				Packet Forward	Power/Fault	Meaning
			G	G	G	G			
G	G	Y	G	G	G	G	G	Y	Initial power-on or reset value
-	-	Y	-	-	-	G	-	G	Performing DRAM test
-	-	Y	-	-	G	-	-	G	Loading firmware
-	-	Y	-	G	-	x	-	G	Firmware initialization
-	-	Y	G	-	-	x	-	G	Performing non-essential, board-level, power-on self-tests
-	-	Y	G	-	G	x	-	G	Performing corebus loopback test
-	-	Y	G	G	-	x	-	G	Performing UART and shared memory test
-	-	Y	G	G	G	x	-	G	Validating firmware parameters
-	-	Y	-	G	G	x	-	G	Updating firmware
-	G	-	-	-	-	x	-	Y	Waiting for boot monitor command
-	G	-	-	G	-	x	-	Y	Performing TFTP get of bridge/router image
-	G	-	-	-	G	x	-	G	Awaiting response to "enter boot monitor?"
-	G	-	-	G	-	x	-	G	Reading bridge/router image composite file into shared memory
-	G	-	-	G	G	x	-	G	Validating composite file
-	G	-	G	-	-	x	-	G	Auto-updating from composite file
-	G	-	G	-	G	x	-	G	Decompressing bridge/router software
-	G	-	G	G	-	x	-	G	Loading bridge/router software
-	G	-	G	G	G	x	-	G	Bridge/router software initializing
G	-	-	x	x	x	x	x	G	Bridge/router software running

Table 2-3 Error indications of LEDs

Run	Load	Test	Status				Packet Forward	Power/Fault	Meaning
G	G	Y	G	G	G	G	G	Y	<i>Board hung very early in firmware load</i> Return module for repair.
-	-	Y	-	-	-	G	-	YF	<i>DRAM test failed</i> Reseat or replace SIMM.
-	-	Y	-	-	G	-	-	YF	<i>Firmware load failed</i> Return module for repair.
-	-	Y	-	-	G	G	-	YF	<i>Attention buttons pressed</i> Reset system to reboot.
-	-	Y	-	G	-	x	-	G	<i>Hang during firmware initialization</i>
-	-	Y	G	-	-	x	-	G	<i>Hang during board-level tests</i> Return module for repair.
-	-	Y	G	-	G	x	-	YF	<i>Corebus loopback test failed</i> Reseat DPE.
-	-	Y	G	G	-	x	-	YF	<i>Serial port or shared memory test failed</i> Return module for repair.
-	-	Y	G	G	G	x	-	YF	<i>FEPROM contents corrupted</i> Return module for repair.
-	G	-	-	G	-	x	-	YF	<i>Unable to load bridge/router image; unable to load from flash memory, or TFTP get failed</i> Replace flash memory card with a backup or verify TFTP parameters and setup.
-	G	-	-	G	G	x	-	YF	<i>No valid bridge/router image file found; bad checksum or magic number</i> Replace flash memory card with a backup.
-	G	-	G	G	-	x	-	YF	<i>No valid bridge/router image; unable to load</i> Replace flash memory card with a backup.
-	G	-	G	G	G	x	-	G	<i>Hang during bridge/router initialization</i>
G	-	-	x	x	x	x	x	YF	<i>Bridge/router software has crashed and entered the debug monitor, as specified by the RA command in the boot monitor or by the SysconF command in the software.</i>

G = green
Y = yellow
x = any value
- = off
F = flashing

Replacing the DPE Module

To replace the DPE module, follow these steps. You will need a small, flatblade screwdriver.



Although it is not required, 3Com recommends that you turn off the system before you remove and reinstall a DPE module.

- 1 Prevent ESD-related damage to the DPE module by following the ESD guidelines presented in Chapter 1.
- 2 Disconnect any cables, if necessary.
- 3 Remove the DPE module from the chassis.
 - a Loosen the two captive screws with the flathead screwdriver.
 - b Press outward firmly and evenly on the ejector tabs.
The DPE module will eject from the slot.
- 4 Install the new DPE module by following the procedure in Chapter 1.

When you replace the DPE module, the firmware parameters that were previously configured by the SysconF command in the software are not automatically updated to the FEPROM of the replacement DPE module. You must reconfigure these parameters. Refer to the software guide for configuration information.

3

FEATURES AND SPECIFICATIONS

This chapter describes the features and specifications of the DPE module.

Features

Table 3-1 summarizes the DPE module features.

Table 3-1 DPE Module Features

Feature	Summary
AMD 29040 RISC main processor	Handles network interfaces and network protocol processing for supported media and protocols and manages data down to the packet level.
DPE 40	50 Mhz
DPE <i>plus</i>	62.5 MHz
Memory	
DPE 40	32 MB (upgradeable to 64 MB) of instruction and data memory and 8 MB of shared (packet) memory provides optimal performance compared with single memory-based systems. See Appendix A for upgrade instructions.
DPE <i>plus</i>	64 MB of instruction and data memory and 16 MB of shared (packet) memory provides optimal performance compared with single memory-based systems.
Two flash memory drives	PC flash memory provides non-volatile, non-rotating, high-capacity base media for software.
Flash PROM	Allows update of firmware without swapping PROMs.
Real-time clock	Allows stamping of date and time for error logs regardless of the state of the network.
Analog-to-digital converter	Allows voltage and temperature monitoring of the DPE module.

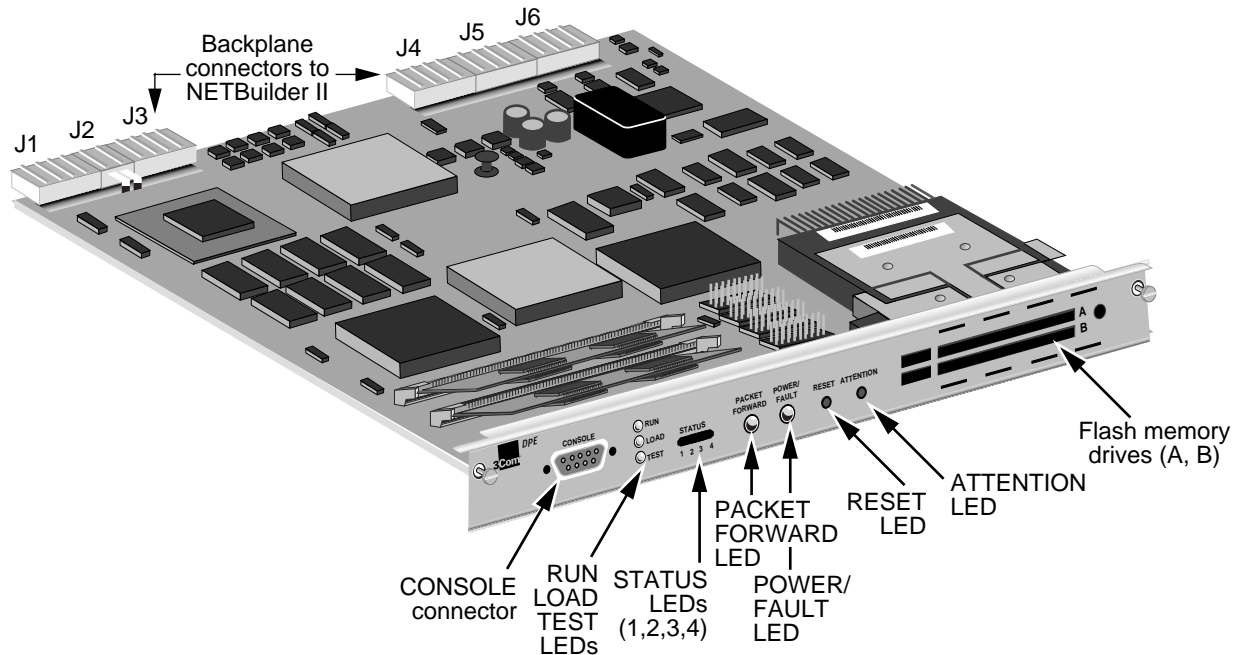

LEDs There are nine LEDs on the front panel of the DPE module:

- **Run and Load** — green
- **Test** — yellow
- **Status** — four green LEDs
- **Packet Forward**— green
- **Power/Fault** — green or yellow

Refer to “LED Patterns” on page 2-2 for LED patterns and their meanings.

LEDs on the Chassis

There are two LEDs on the front of the chassis. The green Power LED indicates whether the system is off or on. The Status LED is exactly the same as the Power/Fault LED on the DPE module. Refer to “LED Patterns” on page 2-2 for more information.

Connectors Table 3-2 describes the module connectors.

Table 3-2 DPE Module Connectors

Location	Connectors	Features	Device Type	Purpose
Backplane connectors	J1, J2, J3, J4, J5, and J6	48-pin	-	Connects module to the core bus.
Front LED/connector panel	Console connector	9-pin male D-subminiature (RS-232)	DTE	Connects module to a modem or terminal. See “Connecting a PC, Terminal, or Modem” on page 1-5 for more information.

Buttons There are two recessed buttons on the module. The Reset button resets the system, the same as pressing the two outer buttons on the chassis LCD control panel or turning the power off then on. Pressing the Attention button (which is the same as pressing the two inner buttons on the LCD control panel) causes one of the following actions, depending on the Recovery Action parameter. If recovery action is set to:

- Reboot — the system will reboot.
- Halt — the system will halt at the debug monitor.
- Dump — the system will perform a memory dump and then reboot.

For more information about the Recovery Action parameter, see *Reference for NETBuilder Family Software*.

LCD Control Panel The LCD control panel on the front of the chassis consists of four buttons below the LCD. The two outer buttons are marked Reset, and the two inner buttons are marked Attention. See “Buttons” above for a description of the Reset and Attention functions.

Physical Specifications

The following tables list physical description and electrical and environmental requirements for the DPE module.

Table 3-3 Physical Description

Length	Width	Height	Weight
9.3 in	10.8 in	1 in	1.4 lbs
23.8 cm	27.7 cm	2.6 cm	0.6 kg

Table 3-4 Maximum Current Consumption

+5 Volts	+12 Volts	-12 Volts
5.101 VDC @ 2.32 amp	11.969 VDC @ 0.011 amp	-12.187 VDC @ 0.008 amp

Table 3-5 Environmental Requirements

Parameter	Requirement	
	Minimum	Maximum
Temperature:		
Operating	41°F (5°C)	104°F (40°C)
Nonoperating	-4°F (-20°C)	140°F (60°C)
Altitude:		
Operating	Sea level	15,000 ft. (4,572 m)
Nonoperating	Sea level	40,000 ft. at 32°F (12,191 m at 0°C)
Relative humidity:		
Operating	20% noncondensing	80% noncondensing
Nonoperating	10% noncondensing	90% noncondensing

A

UPGRADING MEMORY FOR THE DPE 40

The DPE 40 module comes with two 16 MB 72-pin SIMMs of instruction and data memory installed on the board. You can upgrade your memory by replacing the 16 MB SIMMs with two 32 MB SIMMs. Refer to the release notes shipped with this guide for approved memory chip models and vendors.



You must install SIMMs in pairs of equal-sized memory.

Procedure

To upgrade your memory, complete the following:

- 1 Locate the memory sockets on your DPE module, as shown:

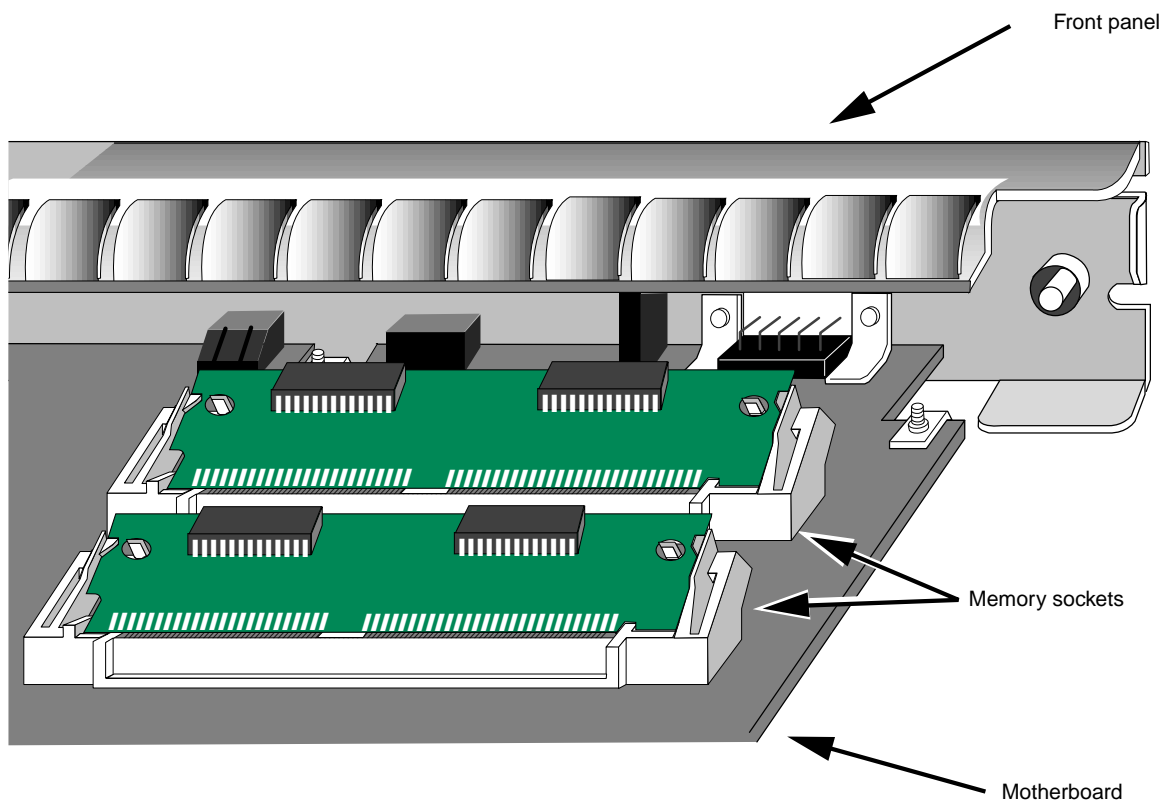

- 2 Remove the 16 MB SIMMs, as shown:

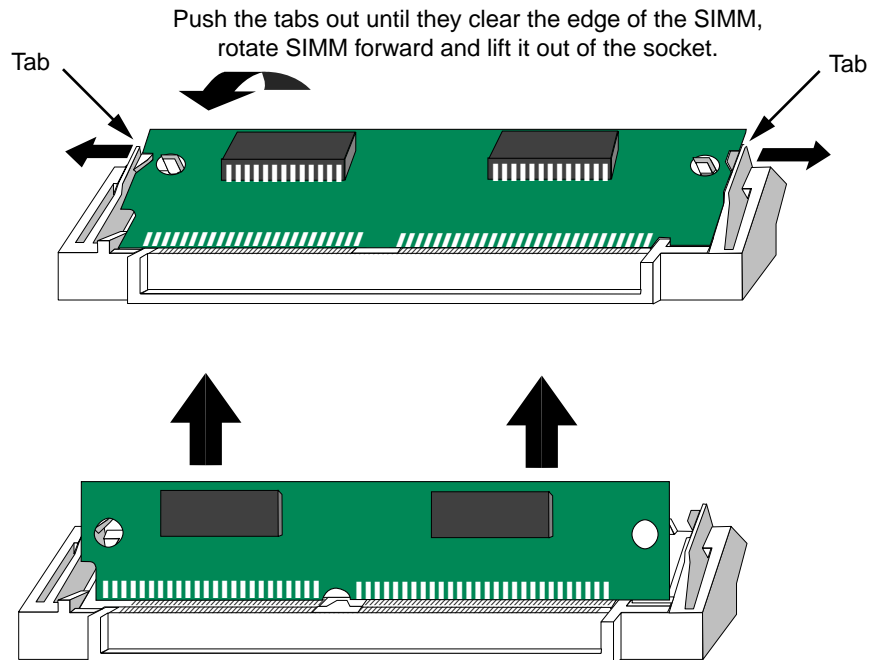

- 3 Insert the new SIMMs, as shown:

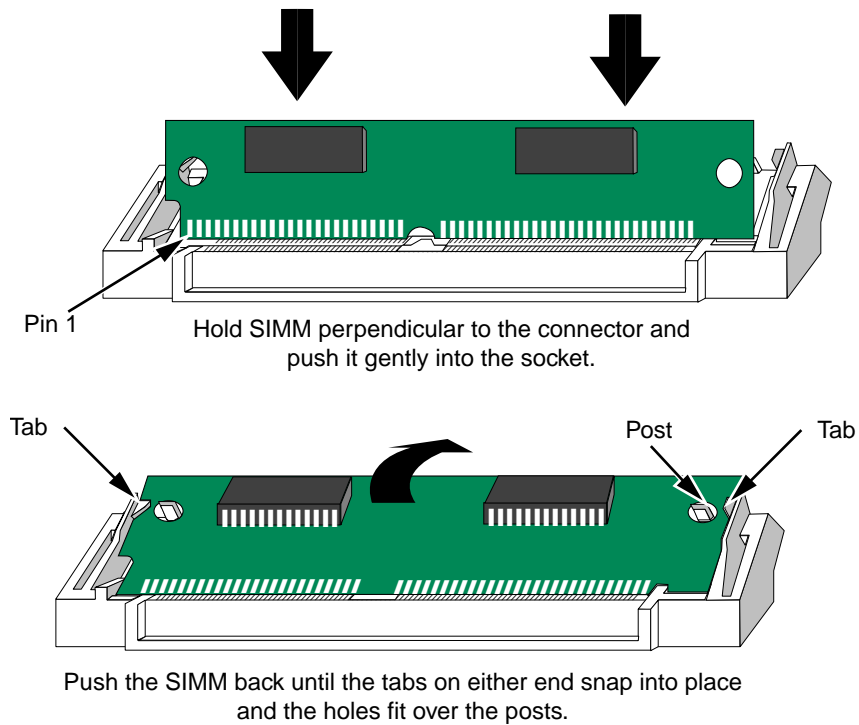

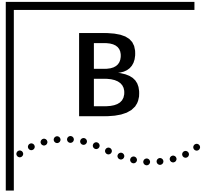

TECHNICAL SUPPORT

3Com provides easy access to technical support information through a variety of services. This appendix describes these services.

Information contained in this appendix is correct at time of publication. For the very latest, we recommend that you access 3Com Corporation's World Wide Web site as described below.

Online Technical Services

3Com offers worldwide product support 24 hours a day, 7 days a week, through the following online systems:

- World Wide Web site
- 3Com Bulletin Board Service (3ComBBS)
- 3ComFactsSM automated fax service
- 3ComForum on CompuServe[®] online service

World Wide Web Site

Access the latest networking information on 3Com Corporation's World Wide Web site by entering our URL into your Internet browser:

<http://www.3Com.com/>

This service features the latest information about 3Com solutions and technologies, customer service and support, news about the company, *NetAge*[®] Magazine, and more.

3Com Bulletin Board Service

3ComBBS contains patches, software, and drivers for all 3Com products, as well as technical articles. This service is available through analog modem or digital modem (ISDN) 24 hours a day, 7 days a week.

Access by Analog Modem

To reach the service by modem, set your modem to 8 data bits, no parity, and 1 stop bit. Call the telephone number nearest you:

Country	Data Rate	Telephone Number
Australia	up to 14400 bps	61 2 9955 2073
Brazil	up to 14400 bps	55 11 547 9666
France	up to 14400 bps	33 1 6986 6954
Germany	up to 28800 bps	4989 62732 188
Hong Kong	up to 14400 bps	852 2537 5608
Italy (fee required)	up to 14400 bps	39 2 27300680
Japan	up to 14400 bps	81 3 3345 7266
Mexico	up to 28800 bps	52 5 520 7853
P. R. of China	up to 14400 bps	86 10 684 92351
Singapore	up to 14400 bps	65 534 5693
Taiwan	up to 14400 bps	886 2 377 5840
U.K.	up to 28800 bps	44 1442 438278
U.S.A.	up to 28800 bps	1 408 980 8204

Access by Digital Modem

ISDN users can dial in to 3ComBBS using a digital modem for fast access up to 56 Kbps. To access 3ComBBS using ISDN, use the following number:

408 654 2703

3ComFacts Automated Fax Service

3Com Corporation's interactive fax service, 3ComFacts, provides data sheets, technical articles, diagrams, and troubleshooting instructions on 3Com products 24 hours a day, 7 days a week.

Call 3ComFacts using your Touch-Tone telephone using one of these international access numbers:

Country	Telephone Number
Hong Kong	852 2537 5610
U.K.	44 1442 438279
U.S.A.	1 408 727 7021

Local access numbers are available within the following countries:

Country	Telephone Number	Country	Telephone Number
Australia	1800 678 515	Netherlands	06 0228049
Belgium	0800 71279	New Zealand	0800 446 398
Denmark	800 17319	Norway	800 11062
Finland	98 001 4444	Portugal	0505 442 607
France	05 90 81 58	Russia (Moscow only)	956 0815
Germany	0130 81 80 63	Singapore	800 6161 463
Hong Kong	800 933 486	Spain	900 964 445
Italy	1678 99085	Sweden	020 792954
Malaysia	1800 801 777	U.K.	0800 626403

3ComForum on CompuServe Online Service

3ComForum is a CompuServe-based service containing patches, software, drivers, and technical articles about all 3Com products, as well as a messaging section for peer support. To use 3ComForum, you need a CompuServe account.

To use 3ComForum:

- 1** Log on to CompuServe.
- 2** Type **go threecom**
- 3** Press [Return] to see the 3ComForum main menu.

Support from Your Network Supplier

If additional assistance is required, contact your network supplier. Many suppliers are authorized 3Com service partners who are qualified to provide a variety of services, including network planning, installation, hardware maintenance, application training, and support services.

When you contact your network supplier for assistance, have the following information ready:

- Diagnostic error messages
- A list of system hardware and software, including revision levels
- Details about recent configuration changes, if applicable

If you are unable to contact your network supplier, see the following section on how to contact 3Com.

Support from 3Com

If you are unable to receive support from your network supplier, technical support contracts are available from 3Com.

Contact your local 3Com sales office to find your authorized service provider using one of these numbers:

Regional Sales Office	Telephone Number
3Com Corporation P.O. Box 58145 5400 Bayfront Plaza Santa Clara, California 95052-8145 U.S.A.	800 NET 3Com <i>or</i> 1 408 764 5000 408 764 5001 (fax)
3Com Asia Limited	
Australia	61 2 9937 5000 (Sydney) 61 3 9866 8022 (Melbourne)
China	8610 68492568 (Beijing) 86 21 63740220 Ext 6115 (Shanghai)
Hong Kong	852 2501 1111
India	91 11 644 3974
Indonesia	6221 572 2088
Japan	81 6 536 3303 (Osaka) 81 3 3345 7251 (Tokyo)
Korea	822 2 319 4711
Malaysia	60 3 732 7910
New Zealand	64 9 366 9138
Phillippines	632 892 4476
Singapore	65 538 9368
Taiwan	886 2 377 5850
Thailand	662 231 8151 4
3Com Benelux B.V.	
Belgium	32 2 725 0202
Netherlands	31 30 6029700
3Com Canada	
Calgary	403 265 3266
Montreal	514 683 3266
Ottawa	613 566 7055
Toronto	416 498 3266
Vancouver	604 434 3266
3Com European HQ	49 89 627320
3Com France	33 1 69 86 68 00

Regional Sales Office	Telephone Number
3Com GmbH	
Austria	43 1 513 4323
Czech Republic/Slovak Republic	420 2 21845 800
Germany (Central European HQ)	49 30 34 98790 (Berlin) 49 89 627320 (Munich)
Hungary	36 1 250 83 41
Poland	48 22 6451351
Switzerland	41 31 996 14 14
3Com Ireland	353 1 820 7077
3Com Latin America	
U.S. Headquarters	408 326 2093
Northern Latin America	305 261 3266 (Miami, Florida)
Argentina	541 312 3266
Brazil	55 11 546 0869
Chile	562 633 9242
Colombia	571 629 4110
Mexico	52 5 520 7841/7847
Peru	51 1 221 5399
Venezuela	58 2 953 8122
3Com Mediterraneo	
Italy	39 2 253011 (Milan) 39 6 5279941 (Rome)
Spain	34 1 383 17 00
3Com Middle East	971 4 349049
3Com Nordic AB	
Denmark	45 39 27 85 00
Finland	358 0 435 420 67
Norway	47 22 18 40 03
Sweden	46 8 632 56 00
3Com Russia	007 095 258 09 40
3Com Southern Africa	27 11 807 4397
3Com UK Ltd.	
	44 131 220 8228 (Edinburgh) 44 161 873 7717 (Manchester) 44 162 889 7000 (Marlow)

Returning Products for Repair

Before you send a product directly to 3Com for repair, you must first obtain a Return Materials Authorization (RMA) number. Products sent to 3Com without RMA numbers will be returned to the sender unopened, at the sender's expense.

To obtain an RMA number, call or fax:

Country	Telephone Number	Fax Number
U.S.A. and Canada	1 800 876 3266, option 2	408 764 7120
Latin America	1 408 326 2927	408 764 7120
Europe, South Africa, and Middle East	44 1442 438125	44 1442 435822
Outside Europe, U.S.A., and Canada	1 408 326 2926	1 408 764 7120

INDEX

Numerics

29040 processor 3-1
3Com Bulletin Board Service
(3ComBBS) B-1
3Com sales offices B-4
3Com URL B-1
3ComFacts B-2
3ComForum B-3
4-Slot chassis installation 1-3
8-Slot chassis installation 1-3

A

AMD processor 3-1
analog-to-digital converter 3-1

B

bulletin board service B-1

C

cable pinouts for console 1-5
chassis LEDs 3-2
clock, real-time 3-1
CompuServe B-3
connectors 3-2
 backplane 3-2
 Console 3-2
Console connector 3-2
conventions
 notice icons, About This Guide 1
current consumption 3-3

D

drive
 flash memory 3-1
 internal 1-1
 floppy disk 1-1

E

electrical requirements 3-3
electrostatic discharge (ESD)
 precautions 1-2
environmental requirements 3-3
Extended chassis installation 1-4

F

fax service. *See* 3ComFacts
firmware parameters 1-1, 2-4
flash memory
 card 1-7
 card cover 1-8
 drive 3-1
 internal 1-1
flash PROM 3-1
floppy disk drive 1-1

I

installation in NETBuilder II 1-1
installation of NETBuilder II
 4-Slot 1-3
 8-Slot 1-3
 Extended 1-4

L

LCD control panel 3-3
LEDs 2-2, 2-3, 3-2
Load LED 2-2, 2-3

M

MAC address 1-2
main processor 3-1
memory
 default 3-1
 SIMMs A-1
 upgrading A-1
modem cable 1-5

N

NETBuilder II installation
 4-Slot 1-3
 8-Slot 1-3
 Extended 1-4
network supplier support B-3

O

online technical services B-1

P

Packet Forward LED 2-2, 2-3
PCMCIA flash memory card 1-7
Power/Fault LED 2-2, 2-3
preinstallation procedure 1-2
processor, main 3-1

R

real-time clock 3-1
replacing DPE module 2-4
returning products for repair B-4
Run LED 2-2, 2-3

S

serial number 1-2
SIMMs A-1
software installation 1-7
Status LED 2-2, 2-3

T

technical support
 3Com URL B-1
 bulletin board service B-1
 fax service B-2
 network suppliers B-3
 product repair B-4
 using CompuServe B-3
terminal
 cable 1-5
 configuration settings 1-7
Test LED 2-2, 2-3
tools needed
 4-Slot chassis 1-3
 8-Slot chassis 1-3
 Extended chassis 1-4
troubleshooting 2-1

U

upgrading
 CEC to DPE 1-1
 memory A-1
URL B-1

W

World Wide Web (WWW) B-1

3Com Corporation LIMITED WARRANTY

HARDWARE

3Com warrants its hardware products to be free from defects in workmanship and materials, under normal use and service, for the following lengths of time from the date of purchase from 3Com or its Authorized Reseller:

Network adapters	Lifetime
Other hardware products (unless specified above)	1 year
Spare parts and spares kits	90 days

If a product does not operate as warranted above during the applicable warranty period, 3Com shall, at its option and expense, repair the defective product or part, deliver to Customer an equivalent product or part to replace the defective item, or refund to Customer the purchase price paid for the defective product. All products that are replaced will become the property of 3Com. Replacement products may be new or reconditioned. Any replaced or repaired product or part has a ninety (90) day warranty or the remainder of the initial warranty period, whichever is longer.

3Com shall not be responsible for any software, firmware, information, or memory data of Customer contained in, stored on, or integrated with any products returned to 3Com for repair, whether under warranty or not.

SOFTWARE

3Com warrants that the software programs licensed from it will perform in substantial conformance to the program specifications therefor for a period of ninety (90) days from the date of purchase from 3Com or its Authorized Reseller. 3Com warrants the media containing software against failure during the warranty period. No updates are provided. 3Com's sole obligation with respect to this express warranty shall be (at 3Com's discretion) to refund the purchase price paid by Customer for any defective software products, or to replace any defective media with software which substantially conforms to 3Com's applicable published specifications. Customer assumes responsibility for the selection of the appropriate applications program and associated reference materials. 3Com makes no warranty or representation that its software products will work in combination with any hardware or applications software products provided by third-parties, that the operation of the software products will be uninterrupted or error free, or that all defects in the software products will be corrected. For any third-party products listed in the 3Com software product documentation or specifications as being compatible, 3Com will make reasonable efforts to provide compatibility, except where the noncompatibility is caused by a "bug" or defect in the third-party's product.

STANDARD WARRANTY SERVICE

Standard warranty service for *hardware* products may be obtained by delivering the defective product, accompanied by a copy of the dated proof of purchase, to 3Com's Corporate Service Center or to an Authorized 3Com Service Center during the applicable warranty period. Standard warranty service for *software* products may be obtained by telephoning 3Com's Corporate Service Center or an Authorized 3Com Service Center, within the warranty period. Products returned to 3Com's Corporate Service Center must be pre-authorized by 3Com with a Return Material Authorization (RMA) number marked on the outside of the package, and sent prepaid, insured, and packaged appropriately for safe shipment. The repaired or replaced item will be shipped to Customer, at 3Com's expense, not later than thirty (30) days after receipt of the defective product by 3Com.

WARRANTIES EXCLUSIVE

IF A 3COM PRODUCT DOES NOT OPERATE AS WARRANTED ABOVE, CUSTOMER'S SOLE REMEDY FOR BREACH OF THAT WARRANTY SHALL BE REPAIR, REPLACEMENT, OR REFUND OF THE PURCHASE PRICE PAID, AT 3COM'S OPTION. TO THE FULL EXTENT ALLOWED BY LAW, THE FOREGOING WARRANTIES AND REMEDIES ARE EXCLUSIVE AND ARE IN LIEU OF ALL OTHER WARRANTIES, TERMS, OR CONDITIONS, EXPRESS OR IMPLIED, EITHER IN FACT OR BY OPERATION OF LAW, STATUTORY OR OTHERWISE, INCLUDING WARRANTIES, TERMS, OR CONDITIONS OF MERCHANTABILITY, FITNESS FOR A PARTICULAR PURPOSE, AND SATISFACTORY QUALITY. 3COM NEITHER ASSUMES NOR AUTHORIZES ANY OTHER PERSON TO ASSUME FOR IT ANY OTHER LIABILITY IN CONNECTION WITH THE SALE, INSTALLATION, MAINTENANCE, OR USE OF ITS PRODUCTS.

3COM SHALL NOT BE LIABLE UNDER THIS WARRANTY IF ITS TESTING AND EXAMINATION DISCLOSE THAT THE ALLEGED DEFECT IN THE PRODUCT DOES NOT EXIST OR WAS CAUSED BY CUSTOMER'S OR ANY THIRD PERSON'S MISUSE, NEGLIGENCE, IMPROPER INSTALLATION OR TESTING, UNAUTHORIZED ATTEMPTS TO REPAIR OR MODIFY, OR ANY OTHER CAUSE BEYOND THE RANGE OF THE INTENDED USE, OR BY ACCIDENT, FIRE, LIGHTNING, OR OTHER HAZARD.

LIMITATION OF LIABILITY

TO THE FULL EXTENT ALLOWED BY LAW, 3COM ALSO EXCLUDES FOR ITSELF AND ITS SUPPLIERS ANY LIABILITY, WHETHER BASED IN CONTRACT OR TORT (INCLUDING NEGLIGENCE), FOR INCIDENTAL, CONSEQUENTIAL, INDIRECT, SPECIAL, OR PUNITIVE DAMAGES OF ANY KIND, OR FOR LOSS OF REVENUE OR PROFITS, LOSS OF BUSINESS, LOSS OF INFORMATION OR DATA, OR OTHER FINANCIAL LOSS ARISING OUT OF OR IN CONNECTION WITH THE SALE, INSTALLATION, MAINTENANCE, USE, PERFORMANCE, FAILURE, OR INTERRUPTION OF ITS PRODUCTS, EVEN IF 3COM OR ITS AUTHORIZED RESELLER HAS BEEN ADVISED OF THE POSSIBILITY OF SUCH DAMAGES, AND LIMITS ITS LIABILITY TO REPAIR, REPLACEMENT, OR REFUND OF THE PURCHASE PRICE PAID, AT 3COM'S OPTION. THIS DISCLAIMER OF LIABILITY FOR DAMAGES WILL NOT BE AFFECTED IF ANY REMEDY PROVIDED HEREIN SHALL FAIL OF ITS ESSENTIAL PURPOSE.

Some countries, states, or provinces do not allow the exclusion or limitation of implied warranties or the limitation of incidental or consequential damages for certain products supplied to consumers or the limitation for personal injury, so the above limitations and exclusions may be limited in their application to you. This warranty gives you specific legal rights which may vary depending on local law.

GOVERNING LAW

This Limited Warranty shall be governed by the laws of the state of California.

3Com Corporation, 5400 Bayfront Plaza, Santa Clara, CA 95052-8145 (408) 764-5000

9/1/96

