

Adapters, Devices, and Cable Information for Micro Channel Bus Systems



Note to Printer:

Print Graphic between registration marks

Book trim size is 8 1/2 by 11 inches

Front cover is 10pt. Carolina stock or equivalent C1S (coated on one side)

Use Color Graphic cvtestc.ps on front cover - Service Book



RS/6000



Adapters, Devices, and Cable Information for Micro Channel Bus Systems

Fourth Edition (April 1998)

The following paragraph does not apply to the United Kingdom or any country where such provisions are inconsistent with local law: THIS PUBLICATION IS PROVIDED "AS IS" WITHOUT WARRANTY OF ANY KIND, EITHER EXPRESS OR IMPLIED, INCLUDING, BUT NOT LIMITED TO, THE IMPLIED WARRANTIES OF MERCHANTABILITY OR FITNESS FOR A PARTICULAR PURPOSE. Some states do not allow disclaimer of express or implied warranties in certain transactions, therefore, this statement may not apply to you.

This publication could include technical inaccuracies or typographical errors. Changes are periodically made to the information herein; these changes will be incorporated in new editions of the publication. The manufacturer may make improvements and/or changes in the product(s) and/or the program(s) described in this publication at any time, without notice.

It is possible that this publication may contain reference to, or information about, products (machines and programs), programming, or services that are not announced in your country. Such references or information must not be construed to mean that these products, programming, or services will be announced in your country. Any reference to a specific licensed program in this publication is not intended to state or imply that you can use only that licensed program. You can use any functionally equivalent program instead.

Requests for technical information about products should be made to your authorized reseller or marketing representative.

© International Business Machines Corporation 1996, 1998. All rights reserved.

AIX is a registered trademark of the International Business Machines Corporation.

Torx is a trademark of Camcar Division of Textron, Inc.

Note to U.S. Government Users -- Documentation related to restricted rights -- Use, duplication or disclosure is subject to restrictions set forth in GSA ADP Schedule Contract with IBM Corp.

Contents

Laser Safety Information	xvii
About This Book	xix
Audience Description	xix
Overview of Contents	xix
ISO 9000	xix
Related Publications	xix
Ordering This Publication	xx
Chapter 1. Adapter Information	1-1
Description of the Adapter Information	1-1
How to Use the Adapter Information	1-1
CSU/CE Feature Installation	1-2
Adapter Identification Reference List for IHV Supplied Adapters	1-3
Adapter Identification Label Cross-Reference List	1-4
FC (2770) Color Graphics Display Adapter (Type 1-1)	1-6
Color Graphics Display Adapter Specifications	1-6
Color Graphics Display Adapter 3-Position RGB Video Connector	1-6
FC (2760) Grayscale Graphics Display Adapter (Type 1-2)	1-7
Grayscale Graphics Display Adapter Specifications	1-7
Grayscale Graphics Display Adapter 15-Position HD-15 Connector	1-8
FC (2780) 8-Bit 3D Color Graphics Processor (Type 1-3)	1-9
8-Bit 3D Color Graphics Processor Specifications	1-9
8-Bit 3D Color Graphics Processor 3-Position Video Connector	1-10
FC (2781) 24-Bit 3D Color Graphics Processor (Type 1-3)	1-11
24-Bit 3D Color Graphics Processor Specifications	1-11
24-Bit 3D Color Graphics Processor 3-Position Video Connector	1-12
FC (4350) Graphics Subsystem Adapters (Type 1-4)	1-13
Graphics Subsystem Adapters Specifications	1-14
Graphics Subsystem Adapter (First type) 3-Position RGB Video Connector	1-14
Graphics Subsystem Adapter (Second type) 68-Position Connector	1-15
FC (2795, 2790) POWER Gt4 and POWER Gt4x 8-Bit Graphics Subsystem (Type 1-5)	1-16
POWER Gt4 and POWER Gt4x 8-Bit Graphics Subsystem Specifications	1-17
POWER Gt4 and POWER Gt4x 8-Bit Graphics Subsystem RGB Video Connector	1-17
FC (2796, 2791) POWER Gt4 and POWER Gt4x 24-bit Graphics Subsystem (Type 1-5)	1-18
POWER Gt4 and POWER Gt4x 24-Bit Graphics Subsystem Specifications	1-19
POWER Gt4 and POWER Gt4x 24-Bit Graphics Subsystem RGB Video Connector	1-19
FC (2711) POWER Gt4xi 8-bit Graphics Subsystem (Type 1-5)	1-20
POWER Gt4xi 8-Bit Graphics Subsystem Specifications	1-21
POWER Gt4xi 8-Bit Graphics Subsystem RGB Video Connector	1-21
FC (2712) POWER Gt4xi 24-bit Graphics Subsystem (Type 1-5)	1-22
POWER Gt4xi 24-Bit Graphics Subsystem Specifications	1-23
POWER Gt4xi 24-Bit Graphics Subsystem RGB Video Connector	1-23
FC (2713) POWER Gt4i 24-bit Graphics Subsystem (Type 1-5)	1-24
POWER Gt4i 24-Bit Graphics Subsystem Specifications	1-25
POWER Gt4i 24-Bit Graphics Subsystem RGB Video Connector	1-25
FC (2777) POWER Gt3 Graphics Subsystem (Type 1-6)	1-26

POWER Gt3 Graphics Subsystem Specifications	1-26
POWER Gt3 Graphics Subsystem RGB Video Connector	1-26
FC (2776) POWER Gt4e Graphics Subsystem (Type 1-8)	1-27
POWER Gt4e Graphics Subsystem Specifications	1-27
POWER Gt4e Graphics Subsystem RGB Video Connector	1-27
FC (2768) POWER Gt3i Graphics Subsystem (Type 1-9)	1-28
POWER Gt3i Graphics Subsystem Specifications	1-28
POWER Gt3i Graphics Subsystem RGB Video Connector	1-28
FC (2820) POWER GXT1000 Graphics Accelerator Attachment Adapter for Attachment of the 7250 (Type 1-A)	1-29
POWER GXT1000 Graphics Accelerator Attachment Adapter Specifications	1-29
POWER GXT1000 Graphics Accelerator Attachment Adapter Connector	1-30
FC (2650) POWER GXT150M Graphics Subsystem (Type 1-D)	1-31
POWER GXT150M Graphics Subsystem Specifications	1-31
POWER GXT150M Graphics Subsystem Display Switch Position Table	1-32
POWER GXT150M Graphics Subsystem 13W3 13-Position Connector	1-33
FC(2850) POWER GXT800M 3D Graphics Adapter W/Texture Memory (Type 1-Q)	1-34
POWER GXT800M 3D Graphics Adapter W/Texture Memory Specifications	1-34
POWER GXT800M 3D Graphics Adapter 15-pin D-Shell (HD-15) Connector	1-36
FC (2980) - Ethernet High-Performance LAN Adapter Type (2-1)	1-37
Ethernet High-Performance LAN Adapter Specifications	1-37
Ethernet High-Performance LAN Adapter 15-Position Connector	1-38
FC (2970) Token-Ring High-Performance Network Adapter (Type 2-2)	1-39
Token-Ring High-Performance Network Adapter Specifications	1-39
Token-Ring High-Performance Network Adapter 9-Position Connector	1-40
FC (2700) 4-Port Multiprotocol Communications Controller (Type 2-3)	1-41
4-Port Multiprotocol Communications Controller Specifications	1-41
4-Port Multiprotocol Communications Controller 78-Position Connector	1-42
FC (2960) X.25 Interface Co-Processor/2 (Type 2-4)	1-43
X.25 Interface Co-Processor/2 Specifications	1-43
X.25 Interface Co-Processor/2 37-Position Connector	1-44
FC (2720) Fiber Distributed Data Interface (FDDI) Single Ring Adapter (Type 2-6)	1-45
FDDI Single Ring Adapter Specifications	1-45
FC (2722) Fiber Distributed Data Interface (FDDI) Dual Ring Upgrade Adapter (Type 2-7)	1-46
FDDI Dual Ring Upgrade Kit Adapter Specifications	1-46
FC (7002 or 7004 and 7022) 4-Port EIA-232-C Multiport/2 Adapter (Type 2-C)	1-47
4-Port EIA-232-C Multiport/2 Adapter Specifications	1-47
4-Port EIA-232-C Multiport/2 Adapter 78-Position and 25-Position Connectors	1-48
FC (7002 or 7004 and 7026) 8-Port EIA-232-C Multiport/2 Adapter (Type 2-D)	1-49
8-Port EIA-232-C Multiport/2 Adapter Specifications	1-49
8-Port EIA-232-C Multiport/2 Adapter 78-Position and 25-Position Connectors	1-50
FC (7002 or 7004 and 7024) 6-Port Synchronous EIA-232-C Multiport/2 Adapter (Type 2-E)	1-51
6-Port Synchronous EIA-232-C Multiport/2 Adapter Specifications	1-51
6-Port Synchronous EIA-232-C Multiport/2 Adapter 78-Position and 25-Position Connectors	1-52
FC (7002 or 7004 and 7030) 4-Port EIA-232-C/4-Port EIA-422-A Multiport/2 Adapter (Type 2-F)	1-53
4-Port EIA-232-C/4-Port EIA-422-A Multiport/2 Adapter Specifications	1-53
4-Port EIA-232-C/4-Port EIA-422-A Multiport/2 Adapter 78-Position and 25-Position Connectors (EIA-232-C Assignments)	1-54
4-Port EIA-232-C/4-Port EIA-422-A Multiport/2 Adapter 78-Position and 25-Position Connectors (EIA-422-A Assignments)	1-54

FC (7002 or 7004 and 7028) 8-Port EIA-422-A Multiport/2 Adapter (Type 2-G)	1-55
8-Port EIA-422-A Multiport/2 Adapter Specifications	1-55
8-Port EIA-422-A Multiport/2 Adapter 78-Position and 25-Position Connectors	1-56
FC (7006 or 7008 and 7042) 8-Port EIA-232-D Portmaster Adapter/A (Type 2-H)	1-57
8-Port EIA-232-D Portmaster Adapter/A Specifications	1-57
8-Port EIA-232-D Portmaster Adapter/A 100-Position and 25-Position Connectors	1-58
FC (7006 or 7008 and 7044) 8-Port EIA-422-A Portmaster Adapter/A (Type 2-I)	1-59
8-Port EIA-422-A Portmaster Adapter/A Specifications	1-59
8-Port EIA-422-A Portmaster Adapter/A 100-Position and 25-Position Connectors	1-60
FC (7006 or 7008 and 7046) 6-Port V.35 Portmaster Adapter/A (Type 2-J)	1-61
6-Port V.35 Portmaster Adapter/A Specifications	1-61
6-Port V.35 Portmaster Adapter/A 100-Position and 25-Position Connectors	1-62
FC (7006 or 7008 and 7048) 6-Port X.21 Portmaster Adapter/A (Type 2-K)	1-63
6-Port X.21 Portmaster Adapter/A Specifications	1-63
6-Port X.21 Portmaster Adapter/A 78-Position and 25-Position Connectors	1-64
FC (2959) Multiprotocol Adapter/A (MP/A) (Type 2-P)	1-65
Multiprotocol Adapter/A Specifications	1-65
Multiprotocol Adapter/A 25-Position Connector	1-66
FC (2724) FDDI-Fiber Single Ring Adapter (Type 2-R)	1-67
FDDI-Fiber Single Ring Adapter Specifications	1-67
FC (2723) FDDI-Fiber Dual Ring Upgrade Kit Adapter (Type 2-S)	1-68
FDDI-Fiber Dual Ring Upgrade Kit Adapter Specifications	1-68
FC (2725) FDDI-STP Single Ring Adapter (Type 2-T)	1-69
FDDI-STP Single Ring Adapter Specifications	1-69
FDDI-STP Single Ring Adapter 9-Position Connector	1-70
FC (2726) FDDI-STP Dual Ring Upgrade Kit Adapter (Type 2-U)	1-71
FDDI-STP Dual Ring Upgrade Kit Adapter Specifications	1-71
FDDI-STP Dual Ring Upgrade Kit Adapter 9-Position Connector	1-72
FC (2930, 2940, 2950) 8-Port Async Adapters (Types 3-1, 3-2, 3-3)	1-73
Specifications for the 8-Port Async Adapters	1-73
78-Position Connector on the 8-Port Async EIA-232 and MIL-STD 188 Adapter	1-74
78-Position Connector on the 8-Port Async EIA-422A Adapter	1-75
FC (2955) 16-Port Async Adapter - EIA-232-D (Type 3-4)	1-76
16-Port Async Adapter - EIA-232-D Specifications	1-76
16-Port Async Adapter - EIA-232 78-Position Connector	1-77
FC (2957) 16-Port Async Adapter - EIA-422A (Type 3-5)	1-78
16-Port Async Adapter - EIA-422A Specifications	1-78
16-Port Async Adapter - EIA-422A 78-Position Connector	1-79
FC (6400) 64-Port Async Controller (Type 3-6)	1-80
64-Port Async Controller Specifications	1-80
8-Position RJ-45 Controller Connector	1-81
FC (6401) 16-Port Async Concentrator	1-82
16-Port Async Concentrator Specifications	1-82
16-Port Async Concentrator 8-Position RJ-45 Input and Output Connectors	1-83
16-Port Async Concentrator Power Transformers	1-84
16-Port Async Concentrator Removable Power Cables	1-85
FC (8128) 128-Port Async Controller (Type 3-7)	1-86
128-Port Async Controller Specifications	1-86
128-Port Async Controller 15-Position HD-15 Connector	1-87
Autoconfiguration	1-87
Remote Async Nodes	1-88
FC (8130, 8137, and 8138) Remote Async Nodes 16-Port Box Style	1-88
FC (8136) Remote Async Node 16-Port EIA-232 Rack Style	1-89
16-Port Remote Async Node Specifications	1-90

Remote Async Node Front Panel	1-91
Programming the Remote Async Node	1-92
16-Port Remote Async Node 10-Position RJ-45 Input and Output Connectors	1-94
16-Port Remote Async Node Power Supplies	1-96
16-Port Remote Async Node Removable Power Cables	1-97
FC (2828, 2835) SCSI Single-Ended High-Performance Internal/External I/O Controller (Type 4-1)	1-98
SCSI Single-Ended High-Performance Internal/External I/O Controller Specification	1-98
SCSI Single-Ended High-Performance Internal/External I/O Controller Connectors	1-99
FC (2420) SCSI-2 Differential High-Performance External I/O Controller (Type 4-2)	1-100
SCSI-2 Differential High-Performance External I/O Controller Specifications	1-100
SCSI-2 Differential High-Performance External I/O Controller Connector	1-101
FC (6210) High Performance Disk Drive Subsystem Adapter (Type 4-3)	1-102
High Performance Disk Drive Subsystem Adapter Specifications	1-102
High Performance Disk Drive Subsystem Adapter Connector	1-102
FC (2410, 2831) SCSI-2 Single-Ended High Performance Internal/External I/O Controller (Type 4-4)	1-103
SCSI-2 Single-Ended High Performance Internal/External I/O Controller Specifications	1-103
SCSI-2 Single-Ended High-Performance Internal/External I/O Controller Connectors	1-104
FC (6211) High-Performance Disk Drive Subsystem Adapter (80M Byte/S) (Type 4-5)	1-105
High Performance Disk Drive Subsystem Adapter (80M Byte/S) Specifications	1-105
High Performance Disk Drive Subsystem Adapter (80M Byte/S) Connector	1-105
FC (2416) SCSI-2 Differential Fast/Wide Adapter/A (Type 4-6)	1-106
SCSI-2 Differential Fast/Wide Adapter/A Specifications	1-106
SCSI-2 Differential Fast/Wide Adapter/A Connectors	1-107
Internal 68-Position 16-Bit Single-Ended High-Density SCSI Bus Connector (J1)	1-108
External 68-Position 16-Bit Differential High-Density SCSI Bus Connector	1-109
FC (2415) SCSI-2 Fast/Wide Adapter/A (Type 4-7)	1-110
SCSI-2 Fast/Wide Adapter/A Specifications	1-110
SCSI-2 Fast/Wide Adapter/A Connectors	1-111
Internal 50-Position Card Edge SCSI Bus Connector	1-111
Internal, External 68-Position 16-Bit Single-Ended High-Density SCSI Bus Connector	1-112
FC (6212) High-Performance Disk Drive Subsystem Adapter (40/80M Byte/S) (Type 4-8)	1-113
High-Performance Disk Drive Subsystem Adapter (40/80M Byte/S) Specifications	1-113
High-Performance Disk Drive Subsystem Adapter (40/80M Byte/S) Connector	1-113
FC (2412) Enhanced SCSI-2 Differential Fast/Wide Adapter/A (Type 4-C)	1-114
Enhanced SCSI-2 Differential Fast/Wide Adapter/A Specifications	1-114
SCSI-2 Differential Fast/Wide Adapter/A Connectors	1-115
Internal 50-Position Card Edge SCSI Bus Connector (J2)	1-115
Internal 68-Position 16-Bit Single-Ended High-Density SCSI Bus Connector (J1)	1-116
External 68-Position 16-Bit Differential High-Density SCSI Bus Connector	1-117
FC (6214) SSA 4-Port Adapter (Type 4-D)	1-118
SSA 4-Port Adapter Specifications	1-118
Light Status	1-119
SSA 4-Port Adapter 9-Position Connector	1-119
FC (6216) Enhanced SSA 4-Port Adapter (Type 4-G)	1-120
Enhanced SSA 4-Port Adapter Specifications	1-120
Light Status	1-121

Enhanced SSA 4-Port Adapter 9-Position Connector	1-121
FC (6217) SSA 4-Port RAID Adapter (Type 4-I)	1-122
SSA 4-Port RAID Adapter Specifications	1-122
SSA 4-Port RAID Adapter Information	1-123
Lights of the SSA 4-Port RAID Adapter	1-123
SSA 4-Port RAID Adapter 9-Position Connector	1-123
FC (6219, 6222) Micro Channel SSA Multi-Initiator/RAID EL Adapter (Type 4-M) and SSA Fast-Write Cache Option	1-124
Micro Channel Multi-Initiator/RAID EL Adapter Specifications	1-124
Micro Channel SSA Multi-Initiator/RAID EL Adapter Information	1-125
Lights of the Micro Channel Multi-Initiator/RAID EL Adapter	1-125
Micro Channel Multi-Initiator/RAID EL Adapter 9-Position Connector	1-126
FC (2990) 3270 Connection (Type 5-1)	1-127
3270 Connection Specifications	1-127
FC (2755) Block Multiplexer Channel Adapter (Type 5-2)	1-128
Block Multiplexer Channel Adapter Specifications	1-128
Block Multiplexer Channel Adapter Connector	1-129
FC (2756) ESCON Channel Adapter (Type 5-3)	1-130
ESCON Channel Adapter Specifications	1-130
FC (2754) ESCON Channel Emulator Adapter (Type 5-3)	1-131
ESCON Channel Adapter Specifications	1-131
FC (2759) S/370 Channel Emulator/A (Type 5-4)	1-132
S/370 Channel Emulator/A Specifications	1-132
S/370 Channel Emulator/A Connector	1-133
FC (2810) Graphics Input Device Adapter (Type 6-1)	1-134
Graphics Input Device Adapter Specifications	1-134
Graphics Input Device Adapter Connectors	1-135
FC (2800) S/370 Host Interface Adapter (Type 6-2) or FC (2801, 2802) 5086/5085 Attachment Adapter	1-136
S/370 Host Interface Adapter / 5080 Attachment Adapter Specifications	1-137
FC (none) Async Expansion Adapter (Type 6-3)	1-138
Async Expansion Adapter Specifications	1-138
FC (2860) Serial Optical Channel Converter (Type 6-4)	1-139
Serial Optical Channel Converter Specifications	1-139
FC (6300) Digital Trunk Adapter (Type 6-5)	1-140
Digital Trunk Adapter Specifications	1-140
Digital Trunk Adapter 25-Position Connector	1-141
FC (6305) Digital Trunk Dual Adapter (Type 6-6)	1-142
Digital Trunk Dual Adapter Specifications	1-142
Digital Trunk Dual Adapter 62-Position Connector	1-143
FC (2840) 5080 Coax Communications Adapter (Type 6-8)	1-145
5080 Coax Communications Adapter Specifications	1-145
FC (6301) M-Audio Capture and Playback Adapter (Type 7-1)	1-146
M-Audio Capture and Playback Adapter Specifications	1-146
FC (2400) M-Video Capture Adapter (Type 7-2)	1-147
M-Video Capture Adapter (NTSC Version) Specifications	1-147
M-Video Capture Adapter 20-Pin Connector	1-148
M-Video Capture Adapter S-Connector	1-148
FC (2401) M-Video Capture Adapter (Type 7-3)	1-149
M-Video Capture Adapter (PAL Version) Specifications	1-149
M-Video Capture Adapter 37-Pin Connector	1-150
FC (2404) Ultimedia Video I/O Adapter (Type 7-5)	1-151
Ultimedia Video I/O Adapter Specifications	1-151

FC (2405) JPEG Compression Option shown Attached to the Ultimedia Video I/O Adapter (Type 7-5)	1-152
Ultimedia Video I/O Adapter Specifications	1-152
Ultimedia Video I/O Adapter Connector	1-153
FC (6302) Ultimedia Audio Adapter (Type 7-6)	1-154
Ultimedia Audio Adapter Specifications	1-154
FC (2402) Network Terminal Accelerator 256 Adapter (Type 8-5)	1-155
Network Terminal Accelerator 256 Adapter Specifications	1-155
Network Terminal Accelerator 256 Adapter 15-Position Connector	1-156
FC (2403) Network Terminal Accelerator 2048 Adapter (Type 8-6)	1-157
Network Terminal Accelerator 2048 Adapter Specifications	1-157
Network Terminal Accelerator 2048 Adapter 15-Position Connector	1-158
FC (2735) High-Performance Parallel Interface (HIPPI) Channel Attachment	1-159
Transmit Card (Type 8-A), Receive Card (Type 8-B)	1-159
HIPPI Attachment Adapter Specifications	1-160
HIPPI Attachment Adapter Cabling	1-160
FC (2972) Auto Token-Ring LANstreamer MC 32 Adapter (Type 8-S)	1-161
Auto Token-Ring LANstreamer MC 32 Adapter Specifications	1-161
Auto Token-Ring LANstreamer MC 32 Adapter Connector	1-162
FC (2992) High-Performance Ethernet LAN Adapter (8F95) AUI and 10BaseT (Type 8-U)	1-163
Ethernet High-Performance LAN Adapter Specifications	1-163
Ethernet High-Performance LAN Adapter (8F95) 15-Position AUI Connector	1-164
Ethernet High-Performance LAN Adapter (8F95) 8-Position RJ-45 Twisted-Pair Connector	1-164
FC (2993) High-Performance Ethernet LAN Adapter (8F95) 10Base2 (Type 8-V)	1-165
Ethernet LAN Adapter Specifications	1-165
FC (2984) TURBOWAYS 100 ATM Adapter (Type 8-W)	1-166
TURBOWAYS 100 ATM Adapter Specifications	1-166
FC (1906) Fibre Channel/266 Adapter (Type 8-X)	1-167
Fibre Channel/266 Adapter Specifications	1-167
FC (2921, 2924, 2928) ARTIC960 4-Port Multiprotocol Communications Controller (Type 9-1)	1-168
ARTIC960 4-Port Multiprotocol Communications Controller Specifications	1-169
ARTIC960 4-Port EIA-232D AIB 100-Position and 25-Position Connectors	1-170
ARTIC960 4-Port EIA-530/RS-422 AIB 100-Position and 25-Position Connectors	1-171
ARTIC960 4-Port ISO-4902 (V.36) AIB 100-Position and 37-Position Connectors	1-172
ARTIC960 4-Port ISO 4903 (X.21) AIB 100-Position and 15-Position Connectors	1-173
FC (2938) ARTIC960 (4M) 8-Port X.21 Communications Controller (Type 9-2)	1-174
ARTIC960 (4M) 8-Port X.21 Communications Controller Specifications	1-174
ARTIC960 (4M) 8-Port ISO 4903 (X.21) AIB 100-Position and 15-Position Connectors	1-175
FC (2929) ARTIC960 (4M) 8-Port EIA-232 E Communications Controller (Type 9-3)	1-176
ARTIC960 8-Port EIA-232 E Communications Controller Specifications	1-176
ARTIC960 8-Port EIA-232 E Communications Controller 100-Position and 25-Position Connectors	1-177
FC (2935) ARTIC960 (4M) 6-Port V.36 Communications Controller (Type 9-4)	1-178
ARTIC960 6-Port V.36 Communications Controller Specifications	1-178
ARTIC960 6-Port ISO-4902 (V.36) AIB 100-Position and 37-Position Connectors	1-180
FC (2989) TURBOWAYS 155 ATM Adapter (Type 9-9)	1-181
TURBOWAYS 155 ATM Adapter Specifications	1-181
FC (1904/1902) Fibre Channel 1063 Adapter Short Wave (Type 9-A)	1-182
Fibre Channel 1063 (Short Wave) Adapter Specifications	1-182
FCS Cables	1-183

FC (2999) 155 ATM Video Streaming Adapter (Type 9-E)	1-184
155 ATM Video Streaming Adapter Specifications	1-184
FC (2994) 10/100 Mbps Ethernet MC Adapter (Type 9-K)	1-185
10/100 Mbps Ethernet MC Adapter Specifications	1-185
10/100 Mbps Ethernet MC Adapter 8-Position RJ-45 Twisted-Pair Connector	1-186
FC (8243) Media Streamer Audio/Video Decoder (Type *)	1-187
Media Streamer Audio/Video Decoder Specifications	1-187
Media Streamer Audio/Video Decoder 15-pin D-Shell Audio Connector	1-188
FC (2734) Keyboard and Mouse Adapter for 7013 Models J30 and J40 (Type *)	1-189
Keyboard and Mouse Adapter Specifications	1-189
Keyboard and Mouse Adapter 6-Position Mini Din Connector	1-190
Keyboard Connector	1-190
Mouse Connector	1-190
Chapter 2. Devices Information	2-1
Description of the Device Information	2-1
How to Use the Device Information	2-1
5.25-Inch Diskette Drive	2-2
Setting the Terminator Resistor	2-2
CD-ROM Drives	2-3
Setting SCSI Addresses	2-4
Type A Drive Switch Settings	2-4
Type B Drive Jumper Settings	2-5
Type C Drive Jumper Settings	2-6
Manually Removing the Disc	2-7
Type A Drives	2-7
Type B Drives	2-9
Type C Drives	2-9
Vertical Orientation	2-10
Terminator Resistors	2-11
1/4-Inch Cartridge Tape Drives	2-12
Setting the SCSI Address	2-12
Internal SCSI Address Connections	2-12
Valid Addresses	2-12
150M-byte, 525M-byte and 1.2G-byte 1/4-Inch Cartridge External Tape Drives	2-13
Setting the SCSI Address	2-13
2.0G-byte 4-mm Tape Drive	2-14
Setting the SCSI Address for External Installations	2-14
Manually Removing the Tape Cartridge	2-15
Removing a Loaded Tape Cartridge	2-15
4.0G-byte 4-mm Tape Drive	2-17
Setting the SCSI Address for External Installations	2-17
4.0GB 4-mm Tape Drives	2-18
Setting the SCSI Address for internal installations	2-18
For Type A Drives	2-18
For Type B Drives	2-19
Manually Removing the Tape Cartridge from a 4-mm Tape Drive	2-20
12.0GB 4-mm Tape Drive	2-26
Setting the SCSI Address	2-26
Manually Removing the Tape Cartridge from the 12.0GB 4-mm Tape Drive	2-26
2.3G-byte 8-mm Tape Drive	2-30
Setting the SCSI Address	2-30
Valid Addresses	2-30
Manually Removing the Tape Cartridge	2-30

Part One of the Cartridge Removal Procedure	2-31
Second Part of the Cartridge Removal Procedure	2-33
Third Part of the Cartridge Removal Procedure	2-34
Door Release and Tape Rewind Procedure	2-37
5G-byte 8-mm Tape Drive	2-39
Setting the SCSI Address for External Installations	2-39
Setting the SCSI Address for Internal Installations	2-40
Valid Addresses	2-40
Manually Removing the Tape Cartridge	2-40
Manually Removing a Loaded Tape Cartridge	2-41
Manually Removing an Unloaded Tape Cartridge	2-42
20.0GB 8-mm Tape Drive	2-43
Setting the SCSI Address	2-43
Manually Removing the Tape Cartridge from an 20GB 8-mm Tape Drive	2-45
160MB SCSI Disk Drive	2-46
Setting the SCSI Address	2-46
Valid Addresses	2-46
200MB SCSI Disk Drive	2-47
Setting the SCSI Address	2-47
Valid Addresses	2-47
320MB and 400MB SCSI Disk Drives	2-48
Setting the SCSI Address	2-48
Valid Addresses	2-48
Exchanging the Logic Card and Frame Assembly	2-48
355MB and 670MB SCSI Disk Drives	2-49
Setting the SCSI Address Jumpers	2-49
Valid Addresses	2-49
Exchanging the Logic Card	2-50
540MB SCSI-2 Single-Ended Disk Drive	2-51
Setting the SCSI Address Jumpers	2-51
Valid Addresses	2-51
857MB SCSI Disk Drive	2-52
Setting the SCSI Address Switches	2-52
Valid Addresses	2-52
857MB Slim-High SCSI Single-Ended Disk Drive	2-53
857MB Slim-High Single-Ended Drive	2-53
Setting the SCSI Address Jumpers	2-53
Valid Addresses	2-53
Exchanging the Frame Electronics	2-53
Logic Card Removal and Replacement Procedures	2-53
Disassembling the Disk Drive	2-55
Assembling the Disk Drive	2-59
1G-byte SCSI Single-Ended and Differential Disk Drives	2-69
Setting the SCSI Address	2-69
Half-High Single-Ended Drives	2-69
Valid Addresses	2-69
Exchanging the Frame Electronics	2-69
Slim-High Single-Ended Drives	2-70
Valid Addresses	2-70
Exchanging the Frame Electronics	2-70
Half-High Differential Drives	2-70
Valid Addresses	2-71
Exchanging the Frame Electronics	2-71
1080MB SCSI-2 Disk Drive	2-72

Setting the SCSI Address Jumpers	2-72
Valid Addresses	2-72
2.1GB SCSI-2 Disk Drive	2-73
Setting the SCSI Address Jumpers	2-73
4.5GB SCSI-2 Disk Drive - Type F1	2-74
Setting the SCSI Address Jumpers	2-74
1.1GB, 2.2GB, 4.5GB, 9.1GB, (50 and 68-pin) Single-Ended Disk Drives	2-76
SCSI-2 Disk Drives	2-77
Setting the SCSI address or SCSI ID	2-77
1.37GB SCSI Disk Drive	2-88
Setting the SCSI Address Jumpers	2-88
Valid Addresses	2-88
Valid Addresses	2-89
Exchanging the Logic Card	2-89
2.0G-byte SCSI-2 Single-Ended and Differential Disk Drives	2-91
Setting the SCSI Address or SCSI ID	2-91
Differential Drives with 50-Pin Connector (Fast 10MB/sec)	2-91
Single-Ended Drives with 50-Pin Connector (Fast 10MB/sec)	2-91
Single-Ended and Differential Drives with 50-Pin Connector (Fast 10MB/sec)	2-92
Single-Ended and Differential Drives with 68-Pin Connector (Fast/Wide 20MB/sec)	2-93
Addresses	2-93
Exchanging the Frame Electronics	2-93
2.4G-byte SCSI Disk Drive	2-94
Setting the SCSI IDs (Addresses)	2-94
Valid Addresses	2-94
HDA Removal and Replacement	2-95
HDA Removal	2-95
HDA Replacement	2-100
Chapter 3. Cables and Cabling	3-1
Adapter Cabling	3-1
Communications Adapter Cabling	3-1
EIA-232 Cabling Considerations	3-1
FC 2930 (8-Port Async Adapter-EIA-232)	3-3
FC 2940 (8-Port Async Adapter-EIA-422A)	3-3
FC 2950 (8-Port Async Adapter MIL-STD 188)	3-4
FC 2955 (16-Port Async Adapter-EIA-232)	3-5
FC 2957 (16-Port Async Adapter-EIA-422A)	3-5
FC 6400 (Async Device Attached to a 64-Port Async Controller)	3-7
FC 8128 (128-Port Async Controller)	3-8
FC 2921, 2924, 2928 (ARTIC960 Adapter)	3-11
FC 2935, 2929, 2938 (ARTIC960 Adapter)	3-12
FC 2959 (Multiprotocol Adapter/A)	3-13
FC 2960 (X.25 Interface Co-Processor/2)	3-13
FC 2700 (4-Port Multiprotocol Communications Controller)	3-14
FC 7002, 7004 Realtime Interface Co-Processor Multiprot/2 Adapter/A	
Configurations	3-15
4-Port EIA-232-C Multiprot/2 Co-Processor Adapter (FC 7022)	3-15
6-Port Synchronous EIA-232-C Multiprot/2 Co-Processor Adapter (FC 7024)	3-15
8-Port EIA-232-C Multiprot/2 Co-Processor Adapter (FC 7026)	3-16
4-Port EIA-232-C/4-Port EIA-422A Multiprot/2 Co-Processor Adapter (FC 7030)	3-16
8-Port EIA-422-A Multiprot/2 Co-Processor Adapter (FC 7028)	3-16
FC 7006, 7008 Realtime Interface Co-Processor Portmaster Adapter/A	
Configurations	3-18

8-Port EIA-232-D Portmaster Adapter (FC 7042)	3-18
8-Port EIA-422-A Portmaster Adapter (FC 7044)	3-18
6-Port V.35 Portmaster Adapter (FC 7046)	3-19
6-Port X.21 Portmaster Adapter (7048)	3-19
FC 2970 (Token-Ring High-Performance Network Adapter)	3-20
FC 2972 (Auto Token-Ring LANstreamer MC 32 Adapter)	3-20
Integrated Ethernet LAN Adapters	3-21
7010 Xstations Ethernet	3-21
Models M20, M2A, 220, and 230 Integrated Ethernet LAN Adapter	3-22
Models 250, 41T, 41W, 42T, and 42W Integrated Ethernet LAN Adapter	3-23
Models 34H, 350, 360, 370, 380, 390, 39H, 3AT, 3BT and 3CT Integrated Ethernet LAN Adapter	3-24
FC 2980 (Ethernet High-Performance LAN Adapter)	3-26
FC 2984, 2989 (TURBOWAYS 100 and 155 ATM Adapter)	3-28
Cable Considerations	3-28
FC 2990 (3270 Connection Adapter)	3-29
FC 2800 (System/370 Host Interface Adapter)	3-29
FC 2801, 2802 (5086/5085 Attachment Adapter)	3-30
FC 2840 (5080 Coax Communication Adapter)	3-30
FC 2720, 2722, 2723, and 2724 (Fiber Distributed Data Interface (FDDI) Adapters) Fiber	3-31
FC 2725 and 2726 Shielded Twisted-Pair (STP) FDDI Adapter	3-33
FC 2860 (Serial Optical Channel Converter)	3-36
FC 2402 and 2403 (Network Terminal Accelerator Adapters)	3-37
10Base-T Cabling	3-37
10Base-2 Cabling	3-38
10Base-5 Cabling	3-38
FC 1904/1902 (Fibre Channel Adapter 1063)	3-39
Cable Considerations	3-39
Multi-mode	3-39
Full Speed	3-39
FC 1906 (Fibre Channel Adapter/266)	3-40
Cable Considerations	3-40
Channel Attachment Adapter Cabling	3-41
FC 2755 (Block Multiplexer Channel Adapter)	3-41
Cable Considerations	3-41
Single Adapter to Single Channel	3-42
Cabling Sequence	3-42
Hardware Considerations	3-43
Software Considerations	3-43
FC 2756 (System/390 ESCON Control Unit Adapter)	3-44
Cable Considerations	3-44
Hardware Considerations	3-45
Software Considerations	3-45
FC 2735 (HIPPI Channel Adapter)	3-45
FC 2759 (S/370 Channel Emulator/A Adapter)	3-46
Single Adapter to Single Channel	3-46
FC 2754 (S/390 ESCON Channel Emulator)	3-47
Cable Considerations	3-47
Software Considerations	3-47
Graphics Adapter Cabling	3-48
FC 2770 (Color Graphics Display Adapter)	3-48
FC 4208 and 2803 (POWER Gt1, Gt1b)	3-48
FC 4207 (POWER Gt1x)	3-49

FC 2768 (POWER Gt4e)	3-49
FC 2711 and 2713 (POWER Gt4i and Gt4xi)	3-50
FC 2766 (POWER GXT100 Graphics Adapter)	3-50
FC 2767 (POWER GXT150 Graphics Adapter)	3-50
FC 2660 (POWER GXT150L Graphics Adapter)	3-51
FC 2650 (POWER GXT150M Graphics Adapter)	3-51
FC 2665 (POWER GXT155L Graphics Adapter)	3-51
FC 2801 and 2802 (5085 or 5086 Attachment Adapters)	3-52
FC 2810 (Graphics Input Device Adapter)	3-52
FC 4350 (7235 Attachment Adapter) POWER GTO Accelerator Adapter	3-53
FC 2820 (7250 Attachment Adapter) POWER GXT1000 Graphics Accelerator	3-53
FC 2850 POWER GXT800M 3D Graphics Adapter W/Texture Memory	3-54
I/O Adapter Cabling	3-56
FC 6211 (High-Performance Disk Drive Subsystem Adapter)	3-56
High-Availability Configurations	3-57
FC 6212 (High-Performance Subsystem Adapter 40/80MB/Sec)	3-58
High-Availability Configurations	3-59
Cabling Considerations for 9333 High-Performance Disk Drive Subsystems	3-60
FC 6214, 6216, 6217, and 6219 (SSA Subsystems Attaching to SSA Adapters)	3-61
SSA Loops, Links, and Data Paths	3-61
Rules for SSA Loops	3-62
SSA Cables for 7133	3-63
SSA Cables for 7131	3-64
FC 2401 (M-Video Capture Adapter)	3-67
FC 6300 (9291/9295 Digital Trunk Adapter)	3-67
FC 6301 (M-Audio Capture and Playback Adapter)	3-67
FC 6302 (Ultimedia Audio Adapter)	3-68
FC 6304 (Ultimedia Video I/O Adapter)	3-68
Standard I/O Ports	3-69
Re-IPL Cabling	3-71
FC 3122 and 3123 (Serial to Re-IPL Port Re-IPL Cables)	3-71
FC 3124 and 3125 (Serial to Serial Port Re-IPL Cables)	3-71
Attaching User Input Devices	3-72
Attaching to the Standard I/O Interfaces	3-72
Keyboard	3-72
Speaker and Keyboard	3-72
Mouse	3-73
5083 Tablet	3-73
6094 Dials and Lighted Program Function Keyboard	3-74
6094 Attached to the Graphics Input Device Adapter	3-74
6094 Attached to Standard I/O Ports S1 and S2	3-75
Attaching the Graphic Displays	3-76
5081 or 6091 Display Attached to a Color Graphics Adapter	3-76
5081 or 6091 Display Attached to a 7235	3-76
8508 Display	3-77
Attaching the External Diskette Drive	3-77
4869 5.25-Inch	3-77
Attaching to the M-Video Capture Adapter (NTSC Version)	3-78
Connecting Input Devices	3-78
Connecting Output Devices	3-79
Attaching to the M-Video Capture Adapter (PAL Version)	3-80
Connecting Input Devices	3-80
Connecting Output Devices	3-81

Chapter 4. SCSI Cabling	4-1
Description of the SCSI Cable Information	4-1
How to Find the 5% You Need to Know	4-2
Cabling SCSI Devices	4-3
External SCSI Devices	4-4
General SCSI Considerations	4-5
Cabling the SCSI I/O Controller FC 2828, 2829, and 2835	4-8
SCSI-1 Single-Ended Cable Lengths Using this Controller	4-8
Cable and Terminator Tables for SCSI-1 I/O Controller	4-8
Terminators for Use with this Controller	4-10
Cabling Examples	4-10
High-Availability SCSI-1 and SCSI-2 Single-Ended Cabling	4-14
Cabling the SCSI-2 Fast/Wide Integrated Controller for Machine Type 7012 Models	
380/390/39H and 7030 Models 3AT/3BT/3CT	4-16
SCSI-2 Single-Ended External Cable Lengths Using This Controller	4-16
Cable and Terminator Tables for the SCSI-2 Single-Ended Fast/Wide Integrated Controller	4-17
Cabling the SCSI-1 Integrated Controller for Machine Types 7012, 7013, and 7015	4-18
SCSI-1 Single-Ended Cable Lengths Using this Controller	4-18
Cable and Terminator Tables for the SCSI-1 Integrated Controller	4-18
Cable Examples for the Integrated Controller	4-20
High-Availability SCSI-1 Integrated Controller	4-20
Cabling the SCSI Integrated Controller for Machine Types 7006, 7008, 7009, and 7011	4-21
SCSI Single-Ended Cable Lengths	4-21
Cable and Terminator Tables for this Controller	4-21
Cabling Examples	4-23
High-Availability with this Controller	4-23
Cabling the SCSI-2 Single-Ended Controller FC 2831 and 2410	4-24
SCSI-2 Single-Ended Cable Lengths Using this Controller	4-24
Cable and Terminator Tables for SCSI-2 Single-Ended Controller	4-25
Terminators for Use with this Controller	4-26
Cabling Examples for the SCSI-2 Single-Ended Controller	4-26
High-Availability SCSI-2 Single-Ended Cabling	4-26
Cabling the SCSI-2 Differential I/O Controller FC 2420	4-28
Identifying SCSI-2 Differential Components	4-28
OEM Components	4-28
SCSI-2 Differential Bus Lengths Using This Controller	4-28
Cable and Terminator Tables for the SCSI-2 Differential Controller	4-29
Differential Terminators for Use with This Controller	4-30
Cabling Examples for the SCSI-2 Differential Controller	4-31
High-Availability Configuration SCSI-2 Differential Cabling	4-33
Cabling the SCSI-2 Single-Ended Fast/Wide Controller FC 2414, 2415, and 9216	4-40
SCSI-2 Single-Ended Cable Lengths Using This Controller	4-40
Cable and Terminator Tables for the SCSI-2 Single-Ended Fast/Wide Controllers	4-41
Controller-to-First Device Cables	4-41
Cable Examples for the SCSI-2 Single-Ended Fast/Wide Controller	4-44
Special Cabling Considerations for the 7131 Single-Ended Interface	4-46
Special Cabling Considerations for the 7027 - HSC Single-Ended Interface	4-47
High-Availability SCSI-2 Single-Ended Fast/Wide Controller Cabling	4-48
Cabling the SCSI-2 Differential Fast/Wide Controller FC 2413, 2416, and 9217	4-49
SCSI-2 Differential Cable Lengths Using This Controller	4-49
Special Cabling Considerations for the 7331-205 or 7331-305 8mm Tape Library or the 7336-205 4mm Tape Library	4-56

Special Cabling Considerations for the 7131 Differential Interface (FC 2508)	4-57
Special Cabling Considerations for the 7027 - HSD Differential Interface	4-58
High-Availability Configuration SCSI-2 Differential Fast/Wide Controller Cabling	4-59
Special Cabling Considerations for the 7131 Differential Interface (FC 2508) High Availability	4-70
Chapter 5. Cable Assembly and Pin-Outs	5-1
Disclaimer	5-1
General Cable Building Information	5-1
Adapter-Specific Cable Building Information	5-1
Cable Description and Page Number	5-2
Cable A	5-3
Cables B and C	5-5
Cable D	5-6
Cable E	5-7
Cable I	5-8
Cable J	5-8
Cable K	5-9
Cable L	5-9
Cable M	5-9
Cable P	5-10
Cable Q	5-11
Cable R	5-12
Cable S	5-13
Cable T	5-13
Cable U	5-14
Cable V	5-15
Cable W	5-16
Cable X	5-17
Cable Z	5-18
Cable AR	5-19
Cable AS	5-20
Cable KK	5-21
64-Port Async Controller to Async Concentrator Cable	5-22
Cable N	5-22
16-Port Concentrator-to-Device Cables	5-24
Cable XX	5-24
Cable YY	5-26
128-Port Async Controller	5-28
128-port async adapter	5-28
Cabling the adapter and the four different Remote Async Nodes	5-28
128-Port Async Controller to Remote Async Node Cables	5-29
Cables NB and NC	5-29
Cable ND	5-31
Cable NE	5-32
Cable NF	5-34
Cable NG	5-35
Cable NH	5-36
Remote Async Node-to-Device Cables	5-37
Cable NK	5-37
Cable NL	5-38
Cable NM	5-40
Cable NP	5-43
Cable RA	5-44

Cable RB	5-45
Multiport/2 4P/8P Interface Cable	5-46
Cable T1	5-46
Cable T2	5-49
Cable T3	5-50
6-Port V.35 Portmaster Adapter/A 100- and 25-Position Connectors	5-50
Cable T4	5-51
Cable T5	5-52
Cable T6	5-54
Cable T7	5-55
Connector Descriptions	5-56
Standard I/O pinouts	5-58
Keyboard Connector	5-58
Mouse Connector	5-58
Tablet Connector	5-59
Serial Port Connectors	5-59
Parallel Port Connector	5-60
External Diskette Connector	5-61
Index	X-1
Reader's Comments — We'd Like to Hear From You	X-3

Laser Safety Information

The optical drive is a laser product. The optical drive has a label that identifies its classification. The label, located on the drive, is shown below.

CLASS 1 LASER PRODUCT LASER KLASSE 1 LUOKAN 1 LASERLAITE APPAREIL À LASER DE CLASSE 1 IEC 825:1984 CENELEC EN 60 825:1991

The optical drive is certified in the U.S. to conform to the requirements of the Department of Health and Human Services 21 Code of Federal Regulations (DHHS 21 CFR) Subchapter J for Class 1 laser products. Elsewhere, the drive is certified to conform to the requirements of the International Electrotechnical Commission (IEC) 825 (1st edition 1984) and CENELEC EN 60 825:1991 for Class 1 laser products.



CAUTION:

A class 3 laser is contained in the device. Do not attempt to operate the drive while it is disassembled. Do not attempt to open the covers of the drive as it is not serviceable and is to be replaced as a unit.

Class 1 laser products are not considered to be hazardous. The optical drive contains internally a Class 3B Gallium Arsenide laser that is nominally 5 Milliwatts at 760 to 810 Nanometers. The design incorporates a combination of enclosures, electronics, and redundant interlocks such that there is no exposure to laser radiation above a Class 1 level during normal operation, user maintenance, or servicing conditions.

About This Book

The adapters, devices and cable information in this book is common to many Micro Channel Bus systems. Care needs to be exercised in that not all adapters and devices apply to all system units. It can be used to help identify an adapter, and designing or servicing cabling layouts for the system. Also included are removal and replacement procedures for some disk drive logic cards and stuck tape removal procedures for some tape drives.

Audience Description

This book is used by service representatives specifically trained on the system unit being serviced and by persons planning for system installation.

Overview of Contents

This book provides information to help service representatives and to help persons planning to install systems. It contains the following chapters:

- Chapter 1, "Adapter Information" on page 1-1 presents information on many Micro Channel adapters used with the system units.
- Chapter 2, "Devices Information" on page 2-1 presents information on devices used with the system units.
- Chapter 3, "Cables and Cabling" on page 3-1 presents information on cabling that can be used with the system units.
- Chapter 4, "SCSI Cabling" on page 4-1 presents information on cabling that can be used with the SCSI products with your system.
- Chapter 5, "Cable Assembly and Pin-Outs" on page 5-1 provides pin-out charts for cables you may want to build yourself or have built by a vendor.

ISO 9000

ISO 9000 registered quality systems were used in the development and manufacturing of this product.

Related Publications

The following is a list of publications that provide information on systems and related products.

- *5080 Graphics System Installation, Operation, and Problem Determination manual*, Order Number GA23-2063.
- *7235 POWER GtO Installation and Service Guide*, Order Number SY66-0216.
- *7250 POWER GXT1000 GRAPHIC Accelerator Service Guide*, Order Number SY66-0219.
- *AIX Versions 3.2 and 4 Asynchronous Communications Guide*, Order Number SC23-2488.

- *Block Multiplexer Channel Adapter User's Guide and Service Information*, Order Number SC23-2427 for more detailed information on planning for, installing, and operating the adapter.
- *Block Multiplexer/6000 User's Guide and Programming Reference*, Order Number SC28-2824 for cabling information.
- *Direct Talk/6000 Problem Solving Guide*, Order Number SC22-0105.
- *Enterprise System Connection Adapter User's Guide and Service Information*, Order Number SC23-2474.
- *ESCON Link Planning*, Order Number GA23-0367.
- *FDDI Adapter User's Guide and Programming Reference*, Order Number SC23-2426.
- *FDDI Introduction and Planning Guide*, Order Number GA27-3892, for more information about jumper cables, planning, design or installation of FDDI systems.
- *FDDI Optical Fiber Planning and Installation Guide*, Order Number GA27-3943 for information regarding FDDI optical systems.
- *Fiber Optic Link Maintenance*, Order Number SY27-2597
- *Planning for Enterprise System Connection Links*, Order Number GA23-0367.
- *Diagnostic Information for Micro Channel Bus Systems* , Order Number SA38-0532.
- *Site and Hardware Planning Information*, Order Number SA38-0508 is a planning and site preparation guide.
- *7133 SSA Disk Subsystem Hardware Technical Information*, Order Number SA33-3261.
- *SSA 4-Port RAID Adapter: Technical Reference*, Order Number SA33-3270.
- *System/360, System/370, 4300, 9370 and ES9000 Processors Input Output Equipment Installation Manual—Physical Planning*, Order Number GC22-7064, for information as some devices may require additional cable length calculations and for details and restrictions regarding channel cabling.
- *System/360 and System/370 Power-Control Interface Original Equipment Manufacturers' Information*, Order Number GA22-6906. The remote power interface as described above is not supported on the system.
- Token-Ring IEEE 802.5 requirements
- *Token-Ring Network Introduction and Planning Guide*, Order Number GA27-3677.
- *A Building Planning Guide for Communication Wiring*, Order Number G320-8059.
- *Cabling System Planning and Installation Guide*, Order Number GA27-3361.
- *Using the Cabling System with Communication Products*, Order Number GA27-3620.

Ordering This Publication

To order additional copies of this book, contact your sales representative and use Order Number SA38-0533.

Chapter 1. Adapter Information

Description of the Adapter Information

This chapter contains service and connector data for the adapters installed within system units. The specific information about these adapters is updated for most versions of the diagnostic programs.

How to Use the Adapter Information

The information about adapters contained in this book is used during non-directed service activities and for new system installations. The information in this chapter is used to:

- Identify an adapter.
- Find specific technical information about an adapter.
- Show signal names for the output pins of most of the adapter connectors.
- Where applicable, show the settings for switches or jumpers.

When a "Microcode file name" is given for an adapter, the file is located in the */etc/microcode* directory unless the complete path name is given. The italic *x* within a file name represents a variable name or number, such as the version number or the release number.

The adapters are labeled to identify the adapter type. If you know the adapter type number, use the Adapter Identification Label Cross-Reference List on the following page to find the name of the adapter. You can also use the About Your Machine listing shipped with your system unit to identify an adapter.

This drawing shows how an adapter is labeled.

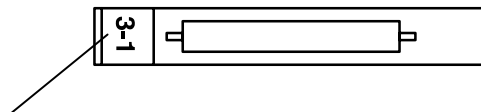

Adapter Type Label

Note: The end brackets of non-OEM SCSI-2 differential adapters also carries the label, "Differential".

OEM SCSI-1 or SCSI-2 single-ended and SCSI-2 differential adapters may carry one of the following ANSI icons:

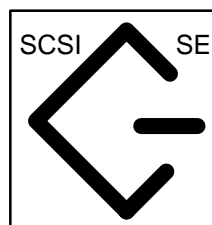

Single-Ended

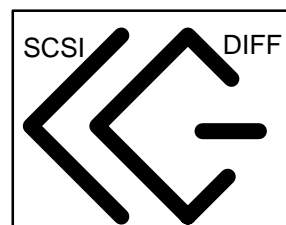

Differential

CSU/CE Feature Installation

Attention: The following information is to indicate which features on various systems/models are intended to be installed by the customer and which features are to be installed by a Customer Engineer/Customer Service Representative (CE/CSR) as part of a Miscellaneous Equipment Specification (MES). This information is for systems/models available as of 04/98.

Notes:

1. 7013 J30 was announced as CSU. US practice has been for CE install.
2. The acronym CSU means Customer Set-Up.

Machine Type	Model	System CSU	Features/Options	
			CE Install	Customer Install
7006	(ALL)	YES	ALL FEATURES	NONE
7007	(ALL)	YES	ALL FEATURES	NONE
7008	(ALL)	YES	ALL FEATURES	NONE
7009	(ALL)	YES	ALL FEATURES	NONE
7010	(ALL)	YES	ALL FEATURES	NONE
7011	(ALL)	YES	ALL FEATURES	NONE
7012	(ALL)	YES	ALL FEATURES	NONE
7013	(ALL) ¹	NO	ALL FEATURES	NONE
7015	(ALL)	NO	ALL FEATURES	NONE
7017	S70	NO	ALL FEATURES	NONE
7024	(ALL)	YES	FC 6309	ALL OTHER FEATURES
7025	(ALL)	YES	FC 2856, 6309, 6549	ALL OTHER FEATURES
7026	(ALL)	NO	ALL OTHER FEATURES	FC 2901,2911, 2913 3071, 3072, 3083
7027	(ALL)	NO	ALL OTHER FEATURES	FC 2616, 3080,3083 3084, 3090, 6142 6147, 3133, 3134 3137, 3138, 6153 6294, 6295
7043	(ALL)	YES	FC 2856 & 6309	ALL OTHER FEATURES
7236	(ALL)	NO	ALL FEATURES	NONE
7248	(ALL)	YES	FC 2856	ALL OTHER FEATURES
7317	(ALL)	NO	ALL FEATURES	NONE
7318	(ALL)	NO	ALL FEATURES	NONE
7319	(ALL)	NO	ALL FEATURES	NONE

Adapter Identification Reference List for IHV Supplied Adapters

Note: The following adapters are supplied by Independent Hardware Vendors (IHVs). They are presented here as a service aid.

Type Label	Description	FRU Part Number
9-M	Eicon ISDN DIVA MCA Adapter for PowerPC Systems	93H5497

Adapter Identification Label Cross-Reference List

Note: This chapter is arranged by adapter type number.

Label	Description	Page
1-1	Color Graphics Display Adapter	1-6
1-2	Grayscale Graphics Display Adapter	1-7
1-3	8-Bit 3D Color Graphics Processor	1-9
1-3	24-Bit 3D Color Graphics Processor	1-11
1-4	Graphics Subsystem Adapter	1-13
1-5	POWER Gt4 and POWER Gt4x 8-Bit Graphics Subsystem	1-16
1-5	POWER Gt4 and POWER Gt4x 24-Bit Graphics Subsystem	1-18
1-5	POWER Gt4xi 8-bit Graphics Subsystem	1-20
1-5	POWER Gt4xi 24-bit Graphics Subsystem	1-22
1-5	POWER Gt4i 24-bit Graphics Subsystem	1-24
1-6	POWER Gt3 Graphics Subsystem	1-26
1-8	POWER Gt4e Graphics Subsystem	1-27
1-9	POWER Gt3i Graphics Subsystem	1-28
1-A	GXT1000 Graphics Accelerator Attachment Adapter	1-29
1-D	POWER GXT150M Graphics Subsystem	1-31
1-Q	POWER GXT800M 3D Graphics Adapter W/Texture Memory	1-34
2-1	Ethernet High-Performance LAN Adapter	1-37
2-2	Token-Ring High-Performance Network Adapter	1-39
2-3	4-Port Multiprotocol Communications Controller	1-41
2-4	X.25 Interface Co-processor/2	1-43
2-6	Fiber Distribution Data Interface (FDDI) Single Ring Adapter	1-45
2-7	Fiber Distribution Data Interchange (FDDI) Dual Ring Upgrade Kit Adapter	1-46
2-C	4-Port EIA-232-C Multiport/2 Adapter	1-47
2-D	8-Port EIA-232-C Multiport/2 Adapter	1-49
2-E	6-Port Synchronous EIA-232-C Multiport/2 Adapter	1-51
2-F	4-Port EIA-232-C/4-Port EIA-422-A Multiport/2 Adapter	1-53
2-G	8-Port EIA-422-A Multiport/2 Adapter	1-55
2-H	8-Port EIA-232-D Portmaster Adapter/A	1-57
2-I	8-Port EIA-422-A Portmaster Adapter/A	1-59
2-J	6-Port V.35 Portmaster Adapter/A	1-61
2-K	6-port X.21 Portmaster Adapter/A	1-63
2-P	Multiprotocol Adapter/A	1-65
2-R	FDDI-Fiber Single Ring Adapter	1-67
2-S	FDDI-Fiber Dual Ring Upgrade Kit Adapter	1-68
2-T	FDDI-STP Single Ring Adapter	1-69
2-U	FDDI-STP Dual Ring Upgrade Kit Adapter	1-71
3-1	8-Port Async Adapter - EIA-232	1-73
3-2	8-Port Async Adapter - EIA-422A	1-73
3-3	8-Port Async Adapter - MIL-STD 188	1-73
3-4	16-Port Async Adapter - EIA-232	1-76
3-5	16-Port Async Adapter - EIA-422A	1-78
3-6	64-Port Async Controller	1-80
3-7	128-Port Async Controller	1-86
4-1	SCSI Internal/External I/O Controller	1-98
4-2	SCSI-2 Differential High Performance External I/O Controller	1-100
4-3	High-Performance Disk Drive Subsystem Adapter	1-102
4-4	SCSI-2 Single-Ended Internal/External I/O Controller	1-103
4-5	High-Performance Disk Drive Subsystem Adapter (80MB/S)	1-105
4-6	SCSI-2 Differential Fast/Wide Adapter/A	1-106
4-7	SCSI-2 Fast/Wide Adapter/A	1-110
4-8	High-Performance Disk Drive Subsystem Adapter (40/80MB/S)	1-113
4-C	Enhanced SCSI-2 Differential Fast/Wide Adapter/A	1-114
4-D	SSA 4-Port Adapter	1-118

Label	Description	Page
4-G	Enhanced SSA 4-Port Adapter (8-Way)	1-120
4-I	SSA 4-Port RAID Adapter	1-122
4-M	Micro Channel Multi-Initiator/RAID EL Adapter	1-124
5-1	3270 Connection	1-127
5-2	Block Multiplexer Channel Adapter	1-128
5-3	Enterprise System Connection ESCON Channel Adapter	1-130
5-3	Enterprise System Connection ESCON Channel Emulator Adapter	1-131
5-4	S/370 Channel Emulator/A	1-132
6-1	Graphics Input Device Adapter	1-134
6-2	5086/5085 Attachment Adapter (AA)	1-136
6-2	System/370 Host Interface Adapter (HIA)	1-136
6-3	Async Expansion Adapter	1-138
6-4	Serial Optical Channel Converter	1-139
6-5	Digital Trunk Adapter	1-140
6-6	Digital Trunk Dual Adapter	1-142
6-8	5080 Coax Communications Adapter	1-145
7-1	M-Audio Capture and Playback Adapter	1-146
7-2	M-Video Capture Adapter (NTSC Version)	1-147
7-3	M-Video Capture Adapter (PAL Version)	1-149
7-5	Ultimedia Video I/O Adapter	1-151
7-5	JPEG Compression Option for Ultimedia Video I/O Adapter	1-152
7-6	Ultimedia Audio Adapter	1-154
8-5	Network Terminal Accelerator Adapter 256	1-155
8-6	Network Terminal Accelerator Adapter 2048	1-157
8-A	HIPPI Transmit Adapter	1-159
8-B	HIPPI Receive Adapter	1-159
8-S	Auto Token Ring LAN Streamer MC 32 Adapter	1-161
8-U	High-Performance 8F95 Ethernet LAN Adapter AUI (10Base5) and 10BaseT	1-163
8-V	High-Performance 8F95 Ethernet LAN Adapter 10Base2	1-165
8-W	TURBOWAYS 100 ATM Adapter	1-166
8-X	Fiber Channel/266 Adapter	1-167
9-1	ARTIC960 4-Port Multiprotocol Adapter	1-168
9-2	ARTIC960 (4M) 8-Port X.21 Communications Controller Adapter	1-174
9-3	ARTIC960 (4M) 8-Port EIA-232 E Communications Controller Adapter	1-176
9-4	ARTIC960 (4M) 8-Port V.36 Communications Controller Adapter	1-178
9-9	TURBOWAYS 155 ATM Adapter	1-181
9-A	Fiber Channel/1063 Adapter Short Wave	1-182
9-E	155 ATM Video Streaming Adapter	1-184
9-K	10/100 Mbps Ethernet MC Adapter	1-185
*	Media Streaming Audio/Video Adapter	1-187
*	Keyboard and Mouse Adapter for models J30 and J40	1-189

Note: Adapters shown with a * do not have an assigned adapter type.

FC (2770) Color Graphics Display Adapter (Type 1-1)

This adapter provides a way to attach the 5081 and 6091 displays to the system units.

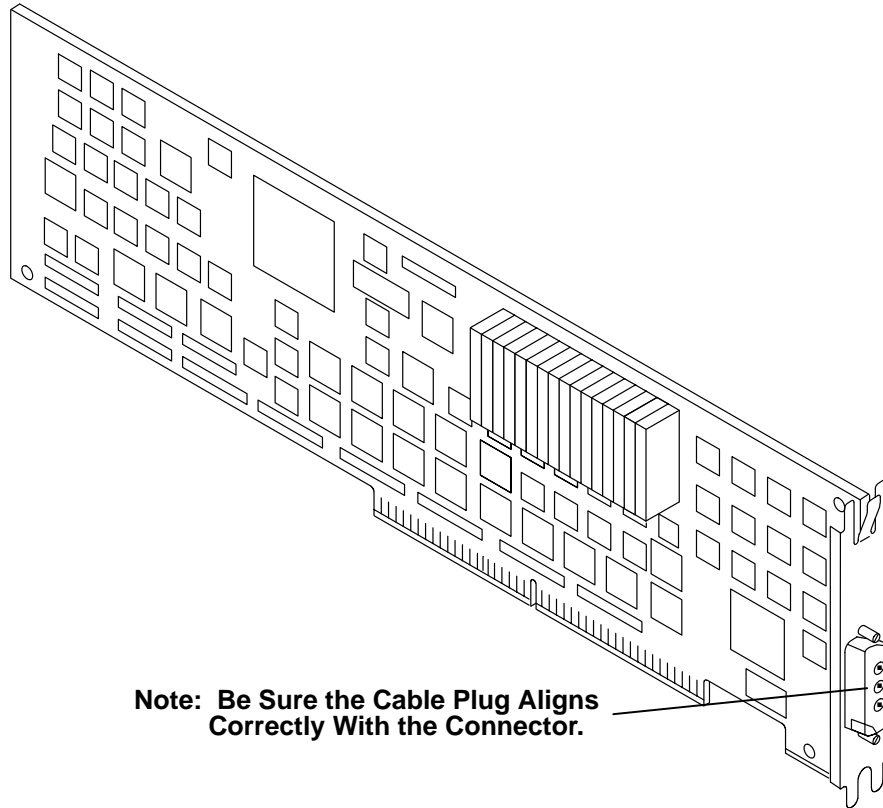

Color Graphics Display Adapter Specifications

FRU Number	71F1223
Resolution	1280 X 1024
Colors	16M (256 active)
Bus architecture	Micro Channel
Adapter size	Type5
Busmaster	Yes
Maximum number	2
Connector	3-position video
Cables	Part number 58F2903.

Color Graphics Display Adapter 3-Position RGB Video Connector

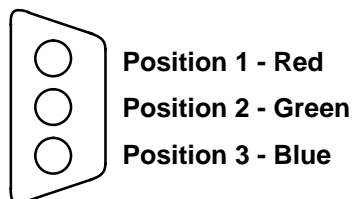

FC (2760) Grayscale Graphics Display Adapter (Type 1-2)

This adapter provides a way to attach the 8508 Monochrome Display to the system units.

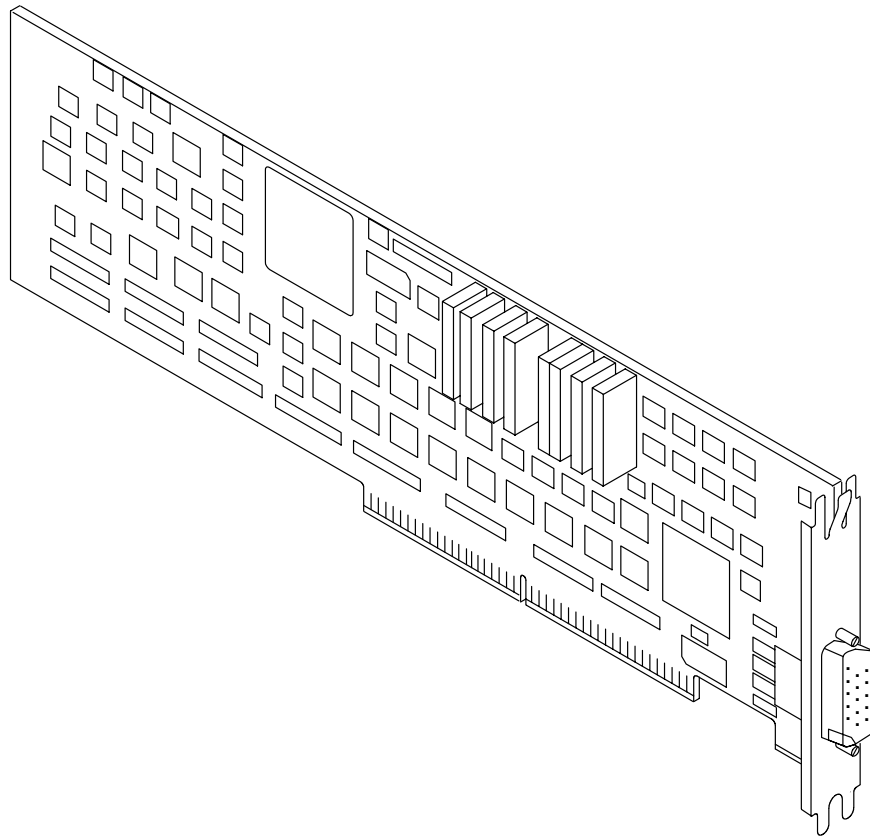

Grayscale Graphics Display Adapter Specifications

FRU Number	71F1224
Resolution	1280 X 1024
Shades of gray	256 (16 active)
Bus architecture	Micro Channel
Adapter size	Type5
Busmaster	Yes
Maximum number	2
Connector	15-position, D-shell
Cables	Attached to the display (two toroid kits, part number 59F4585, are required).

Grayscale Graphics Display Adapter 15-Position HD-15 Connector

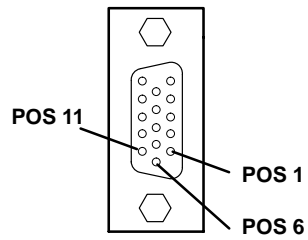

Position	Signal Name
1	Reserved
2	Video
3	Reserved
4	Reserved
5	Signal ground
6	Reserved
7	Video return
8	Reserved
9	Reserved
10	Sync return
11	Reserved
12	Reserved
13	Horizontal sync
14	Vertical sync
15	Reserved

FC (2780) 8-Bit 3D Color Graphics Processor (Type 1-3)

This adapter provides a high-function graphics adapter for the 5081 and 6091 displays.

The high-performance 8-bit 3D graphics processor requires two adjacent adapter slots. The optional Z-buffer solid rendering option attaches to the video interface card.

Note: Be sure each end of the connectors are latched behind the latch bar.

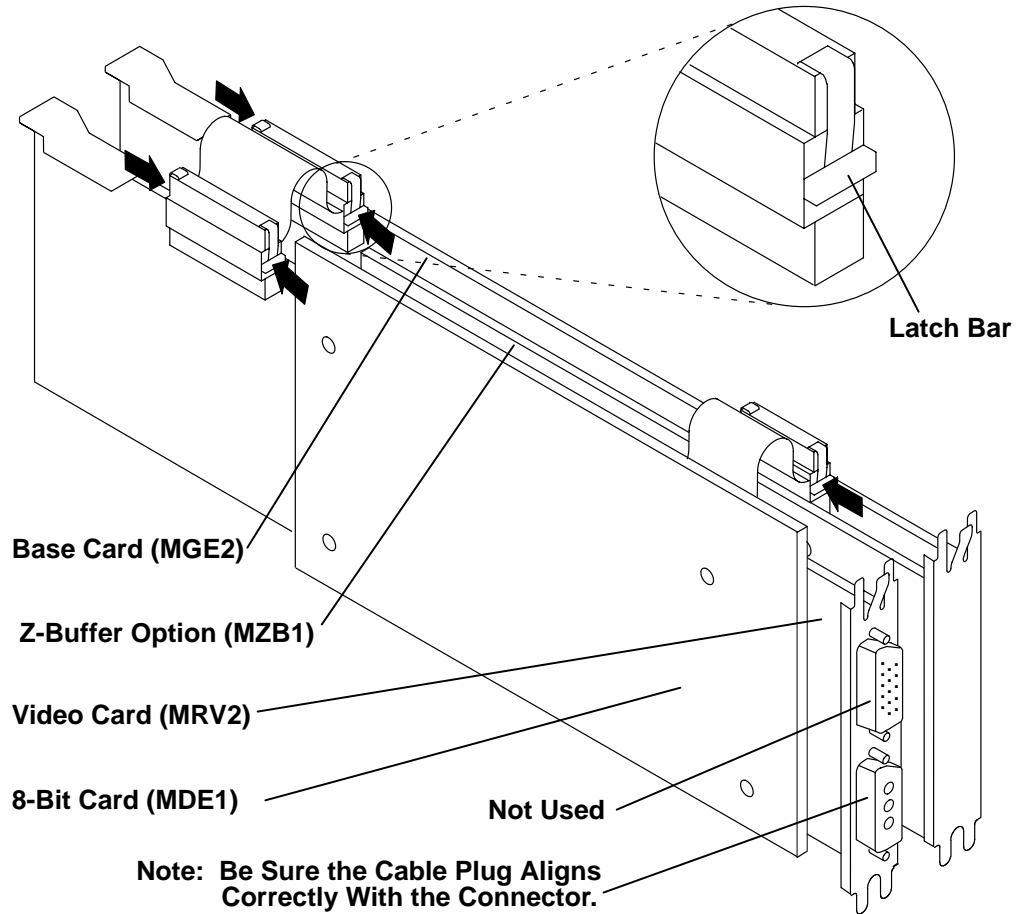

8-Bit 3D Color Graphics Processor Specifications

FRU Numbers	Base card part number 42F6842 (MGE2) Z-buffer option part number 42F6889 (MZB1) Video card part number 71F1151 (MRV2) 8-bit card part number 71F1117 (MDE1) Connector cable (wide) part number 53F3271 Connector cable (narrow) part number 53F3272
Resolution	1280 X 1024
Colors	256 out of 16M
Bus architecture	Micro Channel
Busmaster	Yes
Maximum number	2
Microcode filename	8ee6.xx.xx
Connector	3-position video
Cables	Part number 58F2903.

8-Bit 3D Color Graphics Processor 3-Position Video Connector

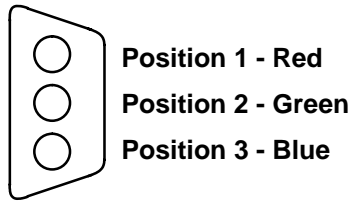

FC (2781) 24-Bit 3D Color Graphics Processor (Type 1-3)

This adapter provides a high-function graphics adapter for the 5081 and 6091 displays. The high-performance 24-bit 3D color graphics processor requires two adjacent adapter slots. The optional 24-bit Z-buffer solid rendering option attaches to the video interface card.

Note: Be sure each end of the connectors are latched behind the latch bar.

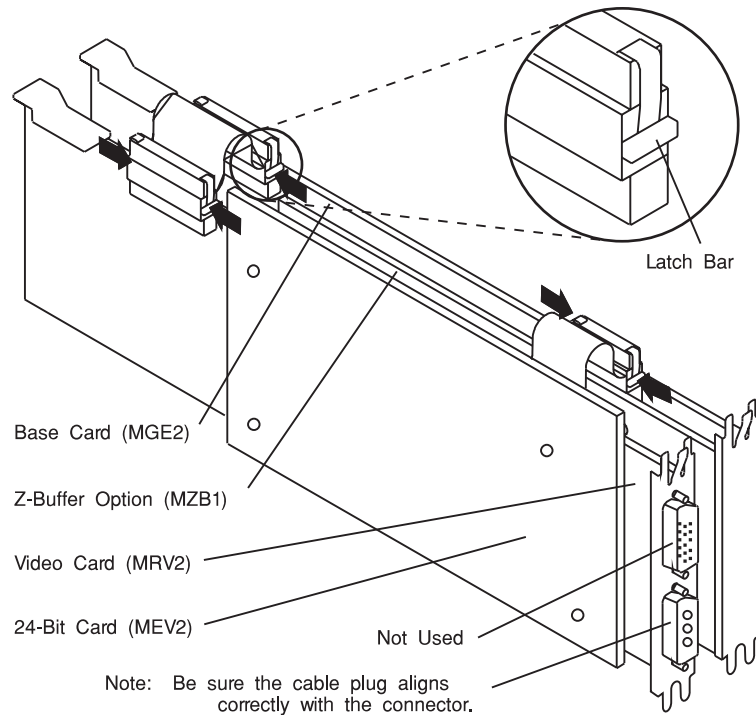

24-Bit 3D Color Graphics Processor Specifications

FRU Numbers	Base card part number 42F6842 (MGE2) Z-buffer option part number 42F6889 (MZB1) Video card part number 71F1151 (MRV2) 24-bit card part number 71F1114 (MEV2) Connector cable (wide) part number 53F3271 Connector cable (narrow) part number 53F3272
Resolution	1280 X 1024
Colors	256 out of 16M
Bus architecture	Micro Channel
Busmaster	Yes
Maximum number	2
Microcode filename	8ee6.xx.xx
Connector	3-position video
Cables	Part number 58F2903.

24-Bit 3D Color Graphics Processor 3-Position Video Connector

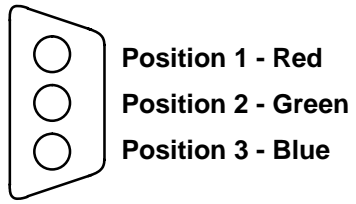

FC (4350) Graphics Subsystem Adapters (Type 1-4)

There are two types of graphic subsystem adapters labeled 1-4.

This adapter is some times referred to as the GtO Accelerator Adapter.

The first type (not shown) is used only in the 7016 system unit. It has two internal connectors to attach the graphics subsystem card cage cables and an external 3-position video connector to attach the display.

The second type (shown below) attaches the 7235 POWER GtO to a system unit. The display attaches to the 7235. See the *"7235 POWER GtO Installation and Service Guide"*, SY66-0216 for additional information about the 7235. This adapter is part of the GtO system.

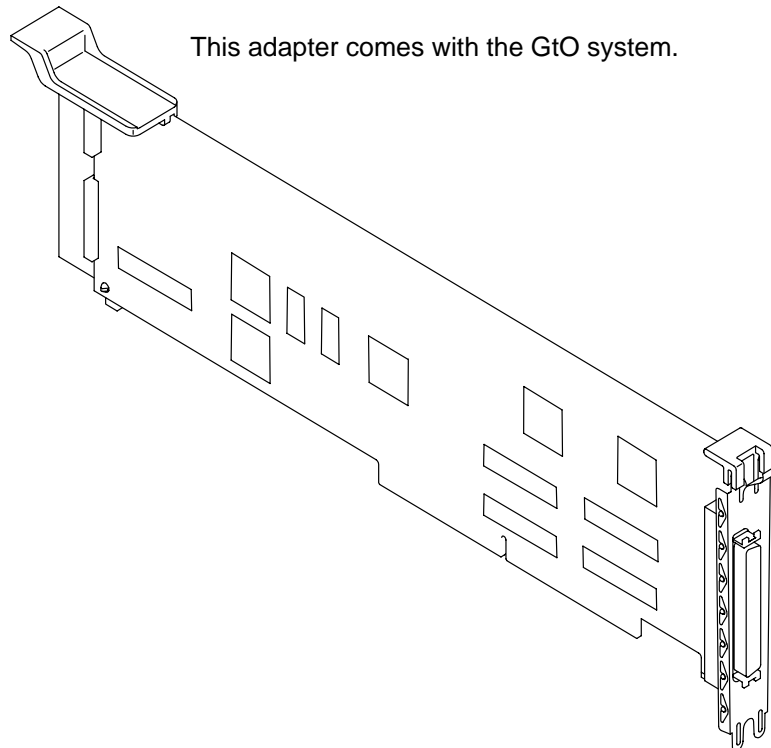

Graphics Subsystem Adapters Specifications

FRU Numbers	First type for 7016, 53F6532 Second type, 74F3158
Resolution	1280 X 1024
Colors	16M (256 active)
Bus architecture	Micro Channel
Busmaster	Yes
Maximum number	1
Microcode file names	8ffdc2.xx.xx 8ffdgt.xx.xx 8ffdgu.xx.xx 8ffdgx.xx.xx 8ffdsh.xx.xx 8ffdvp.xx.xx c25bif.bin g2c25all.bin p3gcpbat.bin
External connectors	3-position video (first type) 68-position D-shell (second type)
Cables	First type, part number 58F2903 Second type, part number 74F3102.

Graphics Subsystem Adapter (First type) 3-Position RGB Video Connector

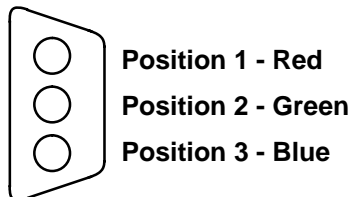

Graphics Subsystem Adapter (Second type) 68-Position Connector

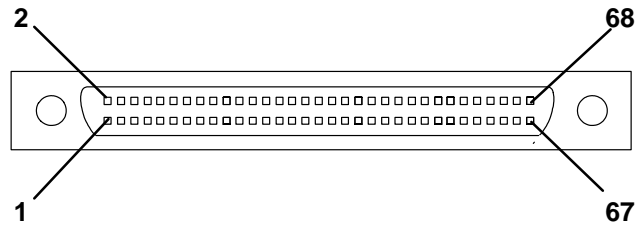

Position	Signal Name	Position	Signal Name
1	Ground	35	AD5
2	-cblcdsel	36	AD6
3	Power on	37	AD7
4	-cblcmd	38	Ground
5	-cblclack	39	AD8
6	-cblcladl	40	AD9
7	Jumper / ground	41	AD10
8	-cblclbusy	42	AD11
9	-cblcltc	43	Ground
10	cblcldefault	44	AD12
11	-cblclend	45	AD13
12	cblclsuspend	46	AD14
13	cblclack	47	AD15
14	Ground	48	Ground
15	cblclwtrd	49	AD16
16	-cblclint	50	AD17
17	-cblclstrobe	51	AD18
18	cblclrst	52	AD19
20	-cblclbe0	53	Ground
19	-cblclbe1	54	AD20
21	-cblclbe2	55	AD21
22	-cblclbe3	56	AD22
23	Ground	57	AD23
24	cblclpar0	58	Ground
25	cblclpar1	59	AD24
26	cblclpar2	60	AD25
27	cblclpar3	61	AD26
28	Ground	62	AD27
29	AD0	63	Ground
30	AD1	64	AD28
31	AD2	65	AD29
32	AD3	66	AD30
33	Ground	67	AD31
34	AD4	68	Ground

FC (2795, 2790) POWER Gt4 and POWER Gt4x 8-Bit Graphics Subsystem (Type 1-5)

This adapter provides a high-function graphics adapter for the 5081 and 6091 displays.

The high-performance 8-bit graphics subsystem requires two adjacent adapter slots. In addition, a performance option card can be attached to the processor card. Addition of this option card changes the name of the subsystem to POWER Gt4x.

Note: Be sure the ends of *all* connectors are latched behind the latch clips. Remove two-position cables first when installing or removing cards. Be sure that all plugs and connectors align correctly.

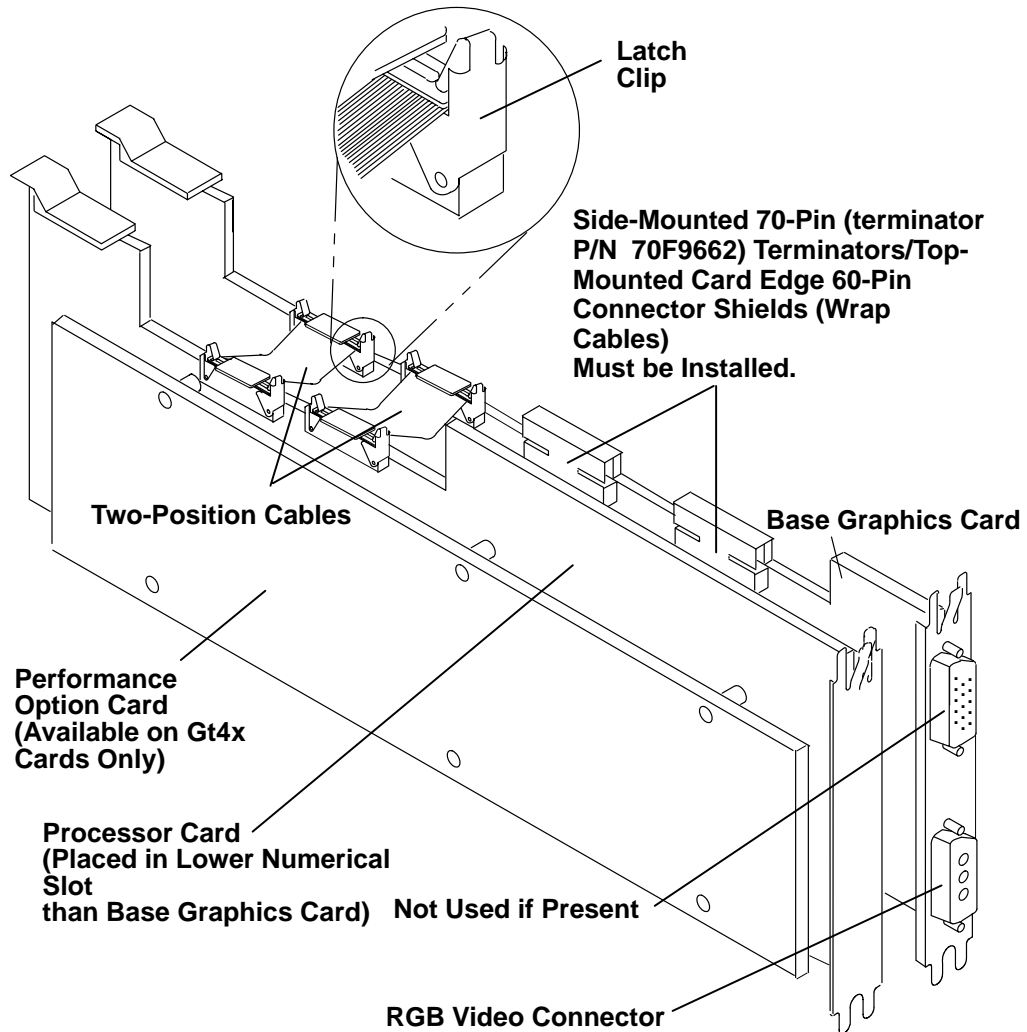

POWER Gt4 and POWER Gt4x 8-Bit Graphics Subsystem Specifications

FRU Numbers	Base Graphics card 41F0499 Processor card 41F0489 Performance option card 70F9664 Connector cable (two-position) part number 51G9225
-------------	---

Note: This FRU contains two cables, one with black connectors, 51G9224, and one with brown connectors, 71F0253. If either of the connectors in the cable being replaced is brown, the replacement cable with the brown connectors must be used; if neither of the connectors in the cable being replaced is brown, the replacement cable with the black connectors must be used.

Resolution	1280 X 1024
Colors	256 out of 16M
Bus architecture	Micro Channel
Busmaster	Yes
Maximum number	2
Microcode filenames	with performance option 8ee3.xx.xx without performance option 8ee3n.xx.xx 8ee3p4d1.xx.xx to 8ee3pd5.xx.xx 8ee3xb.xx.xx 8ee3nb.xx.xx
Other	
Connector	3-position video (RGB)
Cables	RGB, part number 58F2903.
Wrap Cable	70F9662.
Slot Positioning	The processor card must be placed in the lowest numerical slot available, with the graphics card placed in the adjacent, numerically higher slot.

Note: The default refresh rate of this adapter is 60 Hz; a 77 Hz refresh rate can be selected through system software. If video problems are encountered, determine if the display has a 60 Hz-77 Hz refresh rate switch. If so, you may be able to solve the video problem by selecting a different refresh rate.

POWER Gt4 and POWER Gt4x 8-Bit Graphics Subsystem RGB Video Connector

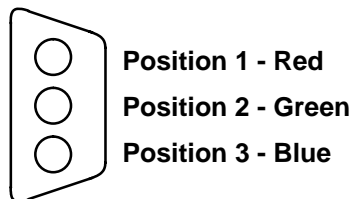

FC (2796, 2791) POWER Gt4 and POWER Gt4x 24-bit Graphics Subsystem (Type 1-5)

This adapter provides a high-function graphics adapter for the 5081 and 6091 displays. The high performance 24-bit graphics subsystem requires three adjacent adapter slots. For more function, a performance option card can be attached to the processor card. Addition of this option card changes the name of the subsystem to POWER Gt4x.

Note: Be sure to install adapters in the configuration illustrated. Be sure the ends of *all* connectors are latched behind the latch clips. Remove two- and three-position cables first when installing or removing cards. Be sure that all plugs and connectors align correctly.

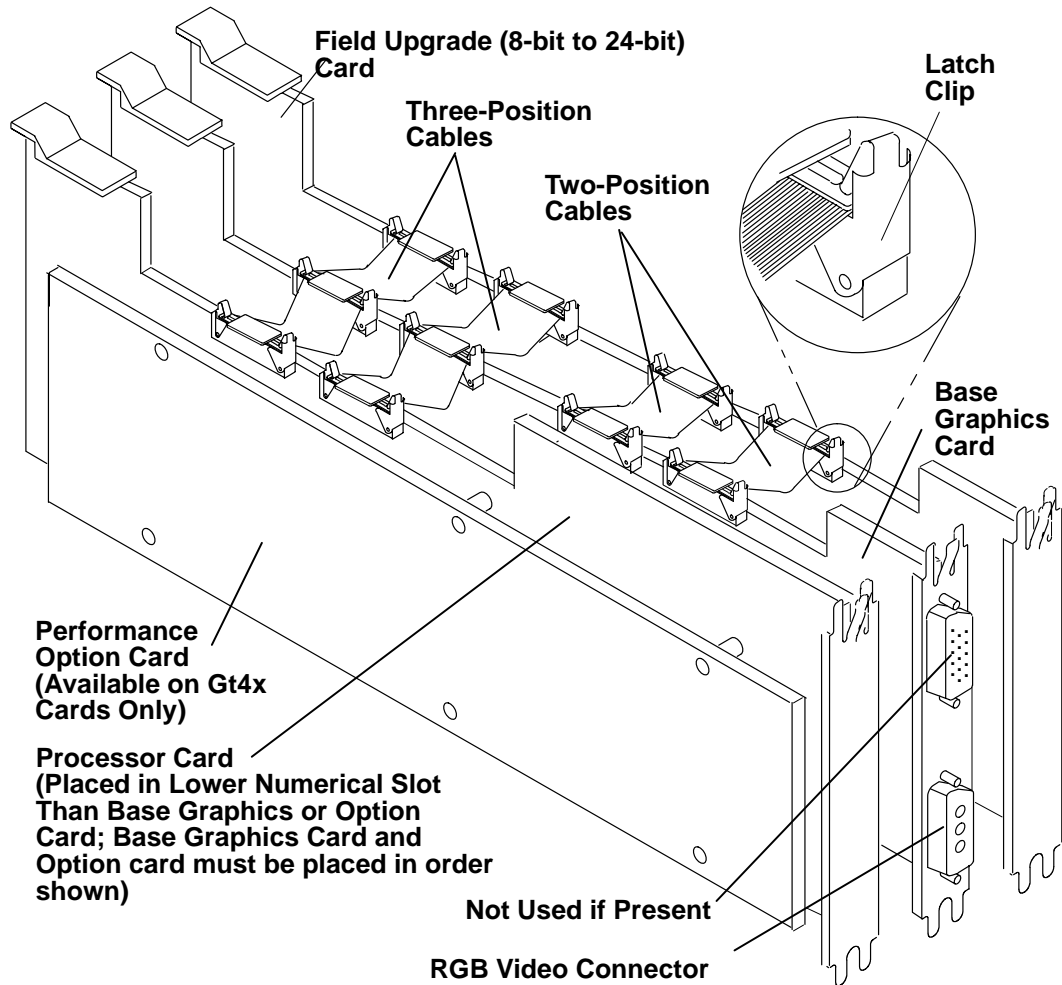

POWER Gt4 and POWER Gt4x 24-Bit Graphics Subsystem Specifications

FRU Numbers	Base graphics card, 41F0499 Field Upgrade (8- to 24-bit) card, 41F0503 Processor card, 41F0489 Performance option card 70F9664 Connector cable (two-position) part number 51G9225 Connector cable (three-position) part number 51G9227
-------------	---

Note: This FRU contains two cables, one with black connectors, 51G9226, and one with brown connectors, 71F0254. If either of the connectors in the cable being replaced is brown, the replacement cable with the brown connectors must be used; if neither of the connectors in the cable being replaced is brown, the replacement cable with the black connectors must be used.

Resolution	1280 X 1024
Colors	to 16M
Bus architecture	Micro Channel
Busmaster	yes
Maximum number	2
Microcode filenames	with performance option card 8ee3.xx.xx without performance option card 8ee3n.xx.xx 8ee3p4d1.xx.xx to 8ee3pd5.xx.xx 8ee3xb.xx.xx 8ee3nb.xx.xx
Connectors	3-position video (RGB)
Cables	RGB, Part number 58F2903.
Slot Positioning	The processor card must be placed in the lowest numerical slot available, with the graphics card and option card, <i>in that order</i> , in the adjacent, numerically higher slots.

Note: The default refresh rate of this adapter is 60 Hz; a 77 Hz refresh rate can be selected through system software. If video problems are encountered, determine if the display has a 60 Hz-77 Hz refresh rate switch. If so, you may be able to solve the problem by selecting a different refresh rate.

POWER Gt4 and POWER Gt4x 24-Bit Graphics Subsystem RGB Video Connector

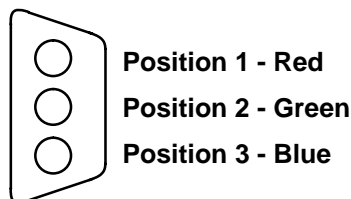

FC (2711) POWER Gt4xi 8-bit Graphics Subsystem (Type 1-5)

This adapter provides a high-function graphics adapter for the 5081 and 6091 displays. The high performance 8-bit graphics subsystem requires two adjacent adapter slots.

Note:

1. Take note when changing the base graphics card. The 41F0499 (first illustration below) has top edge mounted wrap cables. The 52G4123 (second illustration below) does not. Always replace the defective card with one of a similar design.
2. Be sure to install adapters in the configuration illustrated. Be sure the ends of *all* connectors are latched behind the latch clips. Remove the two-position cables first when installing or removing cards. Be sure that all plugs and connectors align correctly.

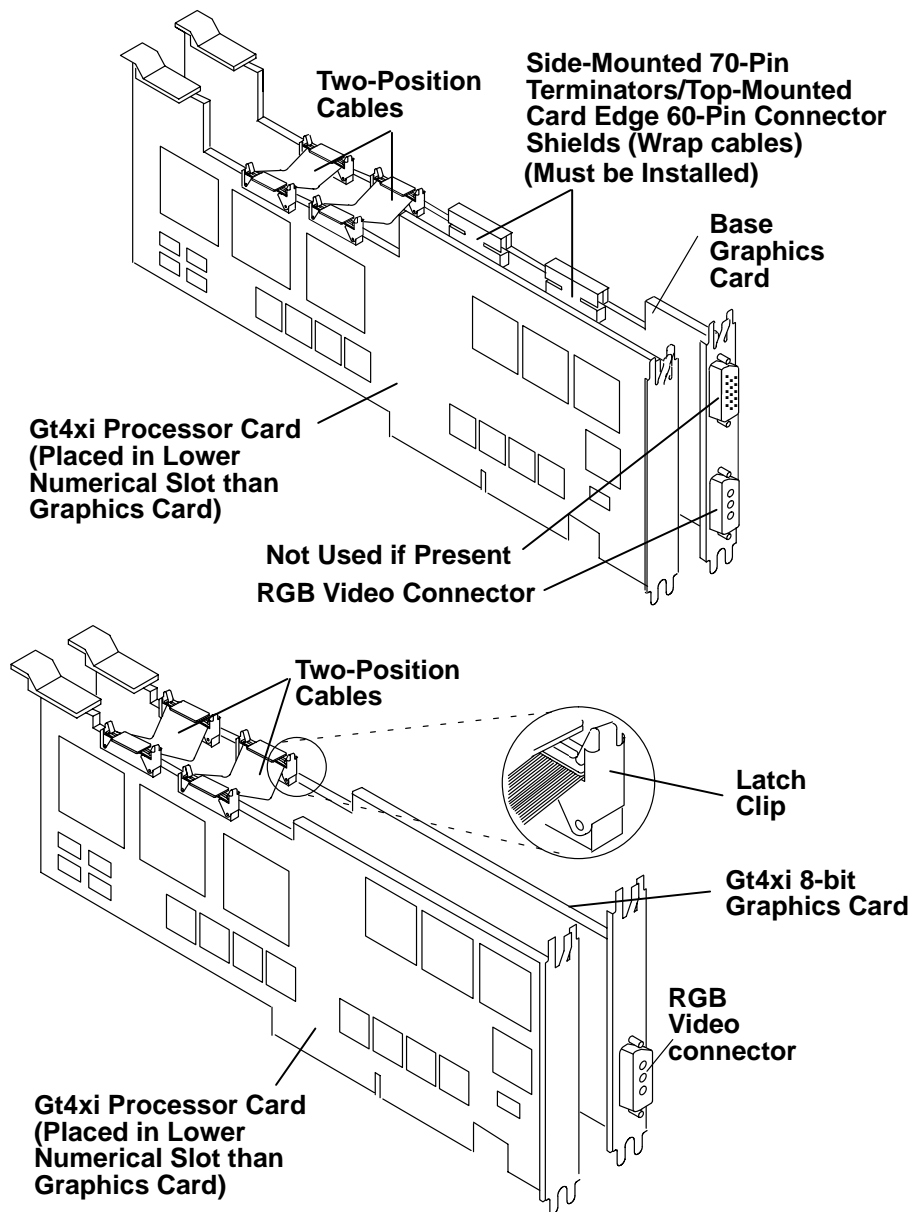

POWER Gt4xi 8-Bit Graphics Subsystem Specifications

FRU Numbers POWER Gt4xi 8-bit graphics card, 41F0499
 POWER Gt4xi 8-bit graphics card, 52G4123
 POWER Gt4xi Processor card, 52G1343
 Connector cable (two-position) part number 51G9225

Note: This FRU contains two cables, one with black connectors, 51G9224, and one with brown connectors, 71F0253. If either of the connectors in the cable being replaced is brown, the replacement cable with the brown connectors must be used; if neither of the connectors in the cable being replaced is brown, the replacement cable with the black connectors must be used.

	Connector cable (two-position) part number 71F0253
Resolution	1280 X 1024
Colors	256 out of 16M
Bus architecture	Micro Channel
Busmaster	Yes
Maximum number	2
Microcode filenames	8ee3.xx.xx
Other	8ee3p4d1.xx.xx to 8ee3p4d5.xx.xx 8ee3xb.xx.xx 8ee3nb.xx.xx
Connectors	3-position video (RGB)
Cables	RGB, Part number 58F2903.
Cable wrap	70F9662
Slot Positioning	The processor card must be placed in the lowest numerical slot available, with the graphics card, <i>in that</i> order, in the adjacent, numerically higher slots.

Note: The default refresh rate of this adapter is 60 Hz; a 77 Hz refresh rate can be selected through system software. If video problems are encountered, determine if the display has a 60 Hz-77 Hz refresh rate switch. If so, you may be able to solve the problem by selecting a different refresh rate.

POWER Gt4xi 8-Bit Graphics Subsystem RGB Video Connector

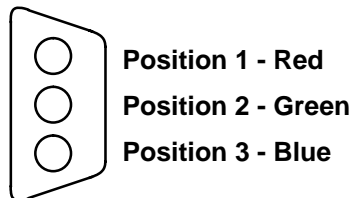

FC (2712) POWER Gt4xi 24-bit Graphics Subsystem (Type 1-5)

This adapter provides a high-function graphics adapter for the 5081 and 6091 displays. The high performance 24-bit graphics subsystem requires two adjacent adapter slots.

Note: Be sure to install adapters in the configuration illustrated. Be sure the ends of all connectors are latched behind the latch clips. Remove the two-position cables first when installing or removing cards. Be sure that all plugs and connectors align correctly.

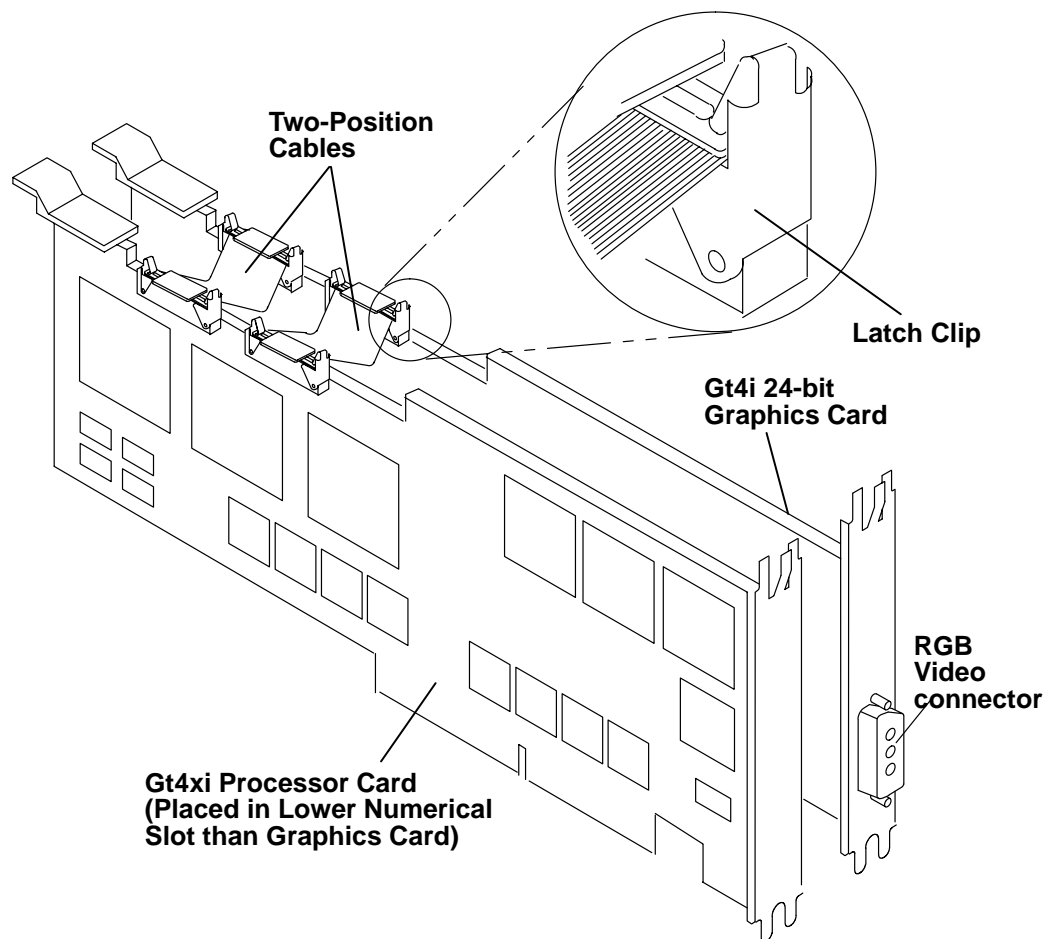

Note: The default refresh rate of this adapter is 60 Hz; a 77 Hz refresh rate can be selected through system software. If video problems are encountered, determine if the display has a 60 Hz-77 Hz refresh rate switch. If so, you may be able to solve the problem by selecting a different refresh rate.

POWER Gt4xi 24-Bit Graphics Subsystem Specifications

FRU Numbers POWER Gt4xi Processor card, 52G1343
 Connector cable (two-position) part number 51G9225

Note: This FRU contains two cables, one with black connectors, 51G9224, and one with brown connectors, 71F0253. If either of the connectors in the cable being replaced is brown, the replacement cable with the brown connectors must be used; if neither of the connectors in the cable being replaced is brown, the replacement cable with the black connectors must be used.

Resolution	1280 X 1024
Colors	Up to 16M
Bus architecture	Micro Channel
Busmaster	Yes
Maximum number	2
Microcode filenames	8ee3.xx.xx
Other	8ee3p4d1.xx.xx to 8ee3p4d5.xx.xx 8ee3xb.xx.xx 8ee3nb.xx.xx
Connectors	3-position video (RGB)
Cables	RGB, Part number 58F2903.
Slot Positioning	The processor card must be placed in the lowest numerical slot available, with the graphics card, <i>in that order</i> , in the adjacent, numerically higher slots.

POWER Gt4xi 24-Bit Graphics Subsystem RGB Video Connector

Position 1 - Red

FC (2713) POWER Gt4i 24-bit Graphics Subsystem (Type 1-5)

This adapter provides a high-function graphics adapter for the 5081 and 6091 displays. The high performance 24-bit graphics subsystem requires two adjacent adapter slots.

Note: Be sure to install adapters in the configuration illustrated. Be sure the ends of *all* connectors are latched behind the latch clips. Remove the two-position cables first when installing or removing cards. Be sure that all plugs and connectors align correctly.

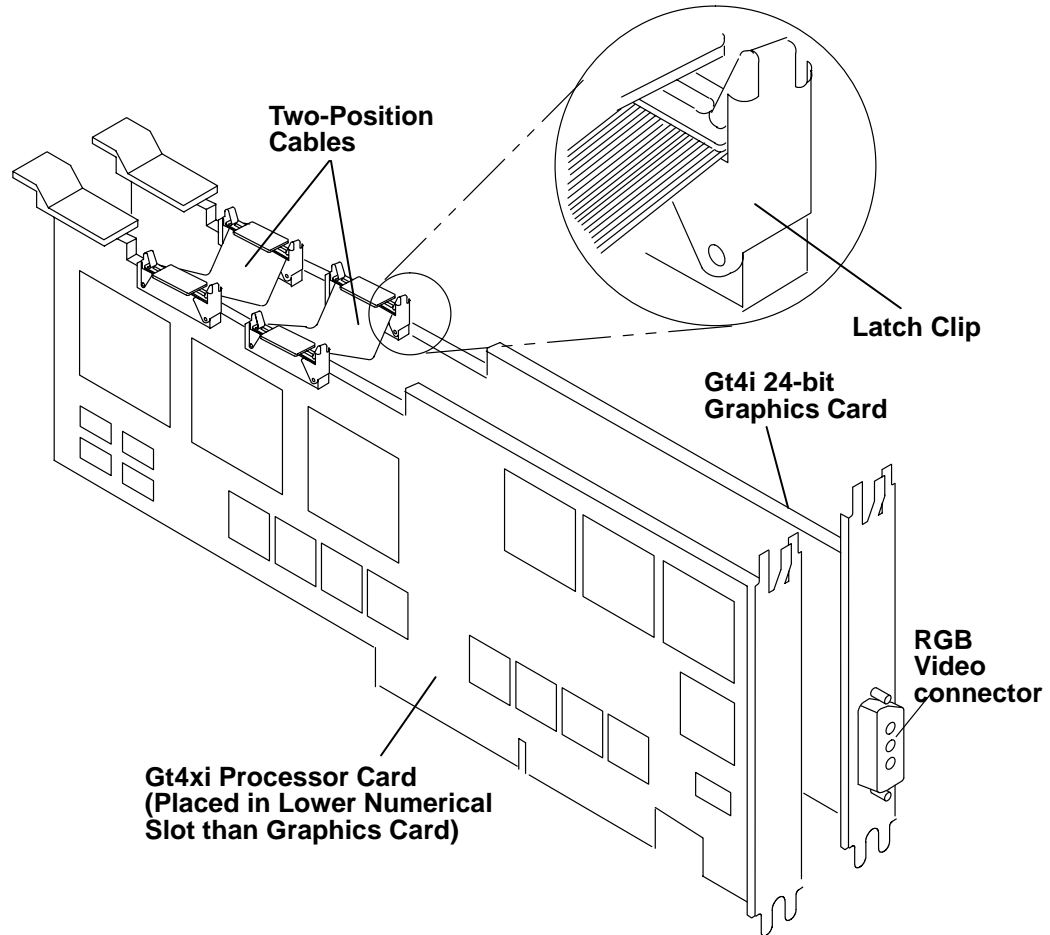

POWER Gt4i 24-Bit Graphics Subsystem Specifications

FRU Numbers POWER Gt4i 24-bit graphics card, 52G4128
 POWER Gt4i Processor card, 52G1338
 Connector cable (two-position) part number 51G9225

Note: This FRU contains two cables, one with black connectors, 51G9224, and one with brown connectors, 71F0253. If either of the connectors in the cable being replaced is brown, the replacement cable with the brown connectors must be used; if neither of the connectors in the cable being replaced is brown, the replacement cable with the black connectors must be used.

Resolution	1280 X 1024
Colors	Up to 16M
Bus architecture	Micro Channel
Busmaster	Yes
Maximum number	2
Microcode filenames	8ee3n.xx.xx
Other	8ee3p4d1.xx.xx to 8ee3p4d5.xx.xx 8ee3xb.xx.xx 8ee3nb.xx.xx
Connectors	3-position video (RGB)
Cables	RGB, Part number 58F2903.
Slot Positioning	The processor card must be placed in the lowest numerical slot available, with the graphics card, <i>in that order</i> , in the adjacent, numerically higher slots.

Note: The default refresh rate of this adapter is 60 Hz; a 77 Hz refresh rate can be selected through system software. If video problems are encountered, determine if the display has a 60 Hz-77 Hz refresh rate switch. If so, you may be able to solve the problem by selecting a different refresh rate.

POWER Gt4i 24-Bit Graphics Subsystem RGB Video Connector

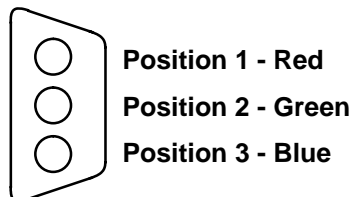

FC (2777) POWER Gt3 Graphics Subsystem (Type 1-6)

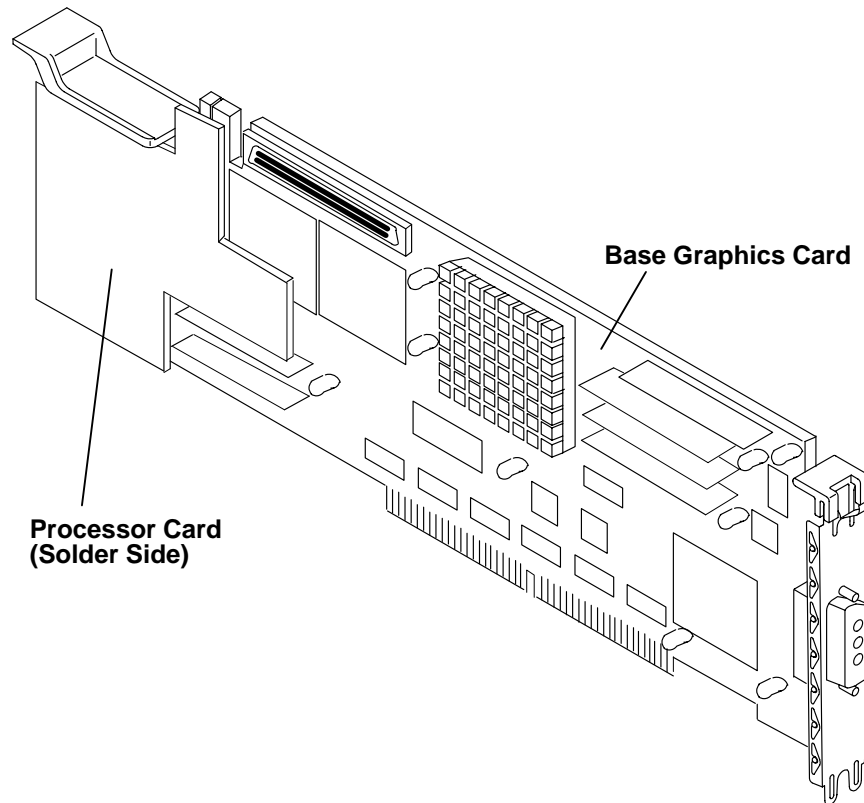

POWER Gt3 Graphics Subsystem Specifications

FRU Numbers	Base graphics card, 00G1117 Processor card, 00G2916
Resolution	1280 X 1024
Colors	Up to 256
Bus architecture	Micro Channel
Busmaster	Yes
Maximum number	4
Microcode filenames	8ee3l.xx.xx 8ee3ld1.xx.xx to 8ee3ld5.xx.xx 8ee3lb.xx.xx
Connectors	3-position video (RGB)
Cables	RGB - Part number 58F2903.

POWER Gt3 Graphics Subsystem RGB Video Connector

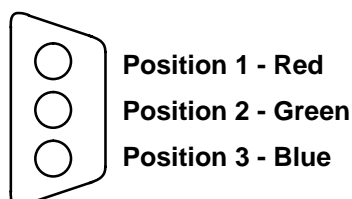

FC (2776) POWER Gt4e Graphics Subsystem (Type 1-8)

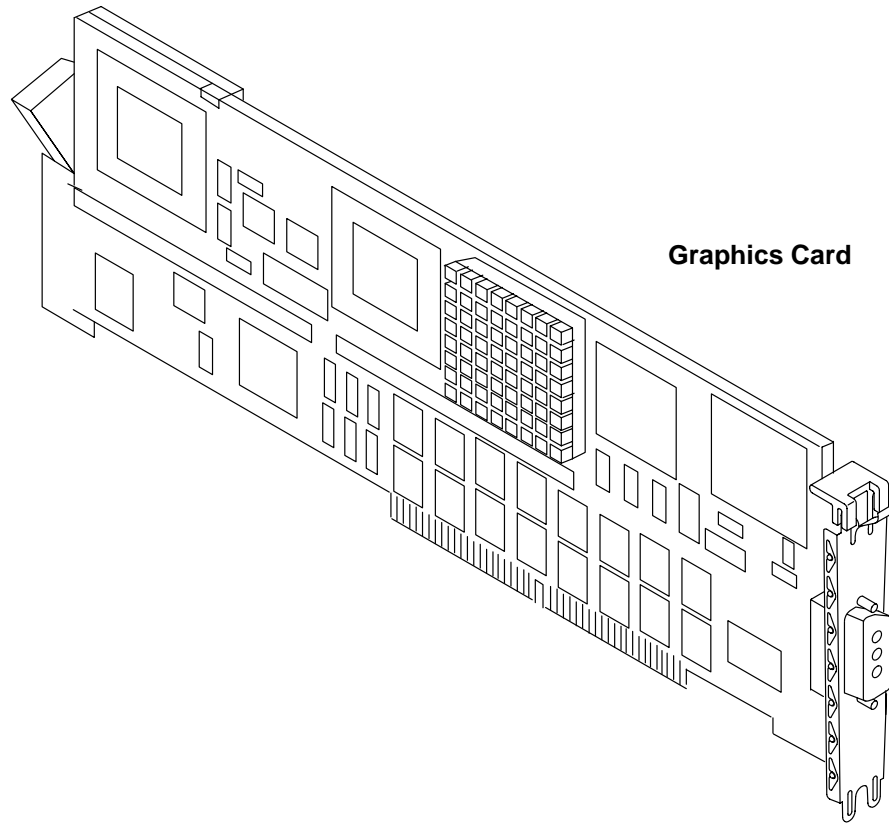

POWER Gt4e Graphics Subsystem Specifications

FRU Number	Base graphics card, 51G8022
Resolution	1280 X 1024
Colors	Up to 256
Bus architecture	Micro Channel
Busmaster	Yes
Maximum number	4
Microcode filenames	8ee3l3.xx.xx 8ee3ld1.xx.xx to 8ee3ld5.xx.xx 8ee3lb.xx.xx
Connectors	3-position video (RGB)
Cables	RGB - Part number 58F2903.

POWER Gt4e Graphics Subsystem RGB Video Connector

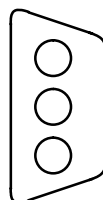

- Position 1 - Red
- Position 2 - Green
- Position 3 - Blue

FC (2768) POWER Gt3i Graphics Subsystem (Type 1-9)

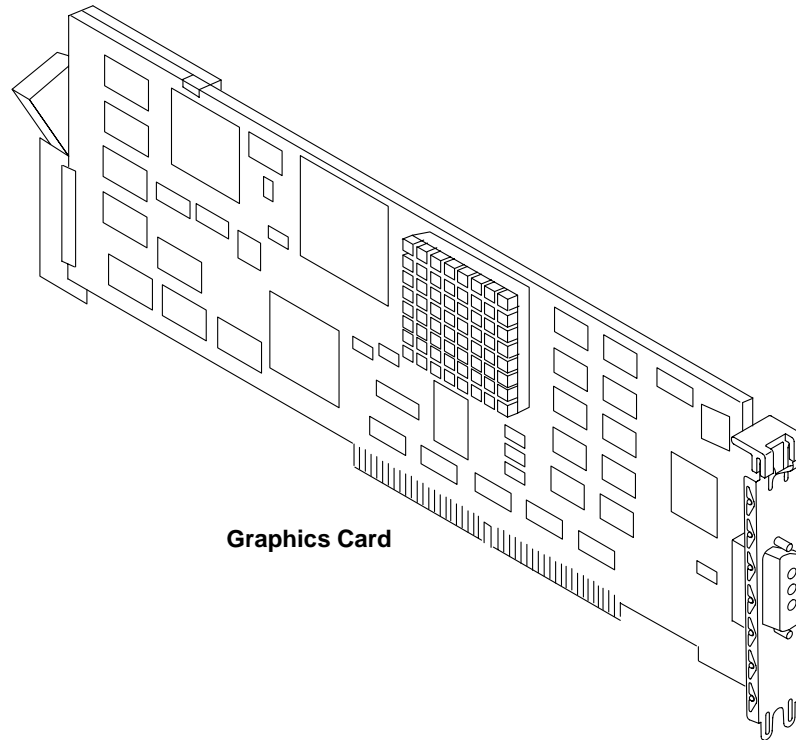

POWER Gt3i Graphics Subsystem Specifications

FRU Number	Base graphics card, 43G0681
Resolution	1280 X 1024
Colors	Up to 256
Bus architecture	Micro Channel
Busmaster	Yes
Maximum number	4
Microcode filenames	8ee3l2.xx.xx 8ee3ld1.xx.xx to 8ee3ld5.xx.xx 8ee3lb.xx.xx
Connectors	3-position video (RGB)
Cables	RGB - Part number 58F2903.

POWER Gt3i Graphics Subsystem RGB Video Connector

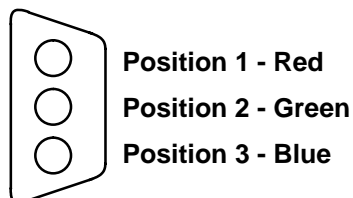

FC (2820) POWER GXT1000 Graphics Accelerator Attachment Adapter for Attachment of the 7250 (Type 1-A)

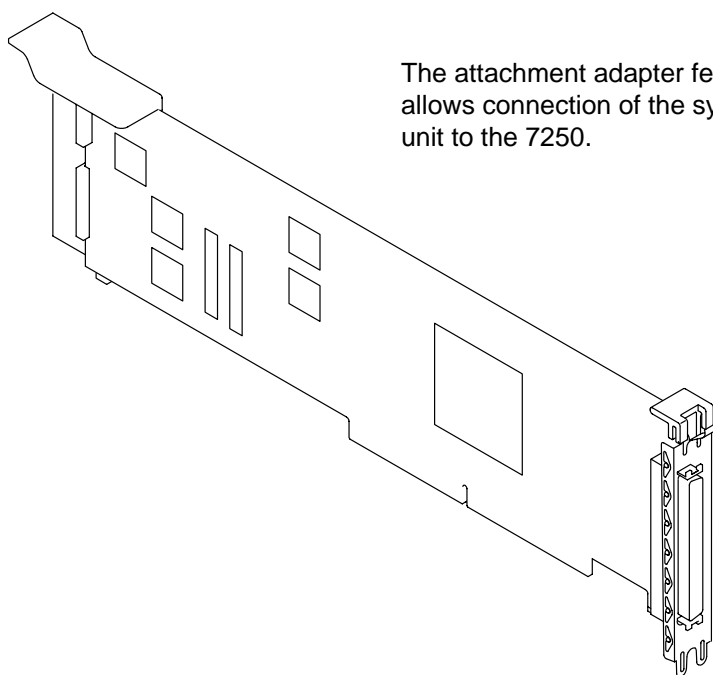

The attachment adapter feature allows connection of the system unit to the 7250.

POWER GXT1000 Graphics Accelerator Attachment Adapter Specifications

FRU Number	7250 POWER GXT1000 Graphics Adapter 65G4886
Resolution	N/A
Colors	N/A
Bus architecture	Micro Channel
Busmaster	Yes
Maximum number	1 for Models 7006, 7009, and 7011 2 for Models 7012, 7013, and 7030
Microcode filenames	There are no microcode filenames for this adapter. Refer to the "7250 POWER GXT1000 Graphic Accelerator Service Guide", order number SY66-0219
Attachment adapter call out	908
Connectors	80 pin
Adapter Cable	Length 2m (6.5 ft) 65G4892

POWER GXT1000 Graphics Accelerator Attachment Adapter Connector

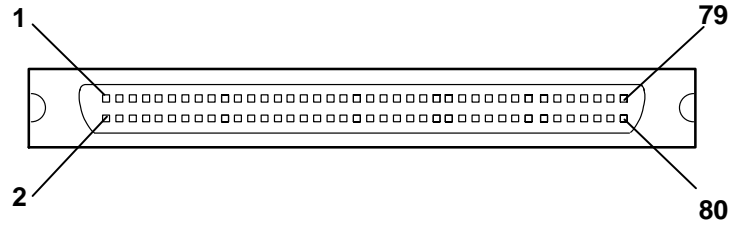

Position	Signal Name	Position	Signal Name
1	addr00	41	-req
2	addr01	42	-ccmrom
3	addr02	43	trans64/32
4	addr03	44	cpdmatc0
5	addr04	45	sedmatc0
6	addr05	46	-breq
7	addr06	47	-rdy
8	addr07	48	avail
9	addr08	49	data00
10	addr09	50	data01
11	addr10	51	data02
12	addr11	52	data03
13	addr12	53	data04
14	addr13	54	data05
15	addr14	55	data06
16	addr15	56	data07
17	addr16	57	data08
18	addr17	58	data09
19	addr18	59	data10
20	addr19	60	data11
21	addr20	61	data12
22	addr21	62	data13
23	addr22	63	data14
24	addr23	64	data15
25	addr24	65	data16
26	addr25	66	data17
27	addr26	67	data18
28	addr27	68	data19
29	addr28	69	data20
30	addr29	70	data21
31	addr30	71	data22
32	addr31	72	data23
33	-reset	73	data24
34	-busy	74	data25
35	-int	75	data26
36	poweron	76	data27
37	-chchk	77	data28
38	rw	78	data29
39	-strobe	79	data30
40	-bgnt	80	data31

FC (2650) POWER GXT150M Graphics Subsystem (Type 1-D)

The POWER GXT150M graphics subsystem is designed for superior 2D performance. It has excellent line drawing and Bit Block Transfer operation on top of its enhanced graphics capabilities. This adapter is available for Micro Channel models.

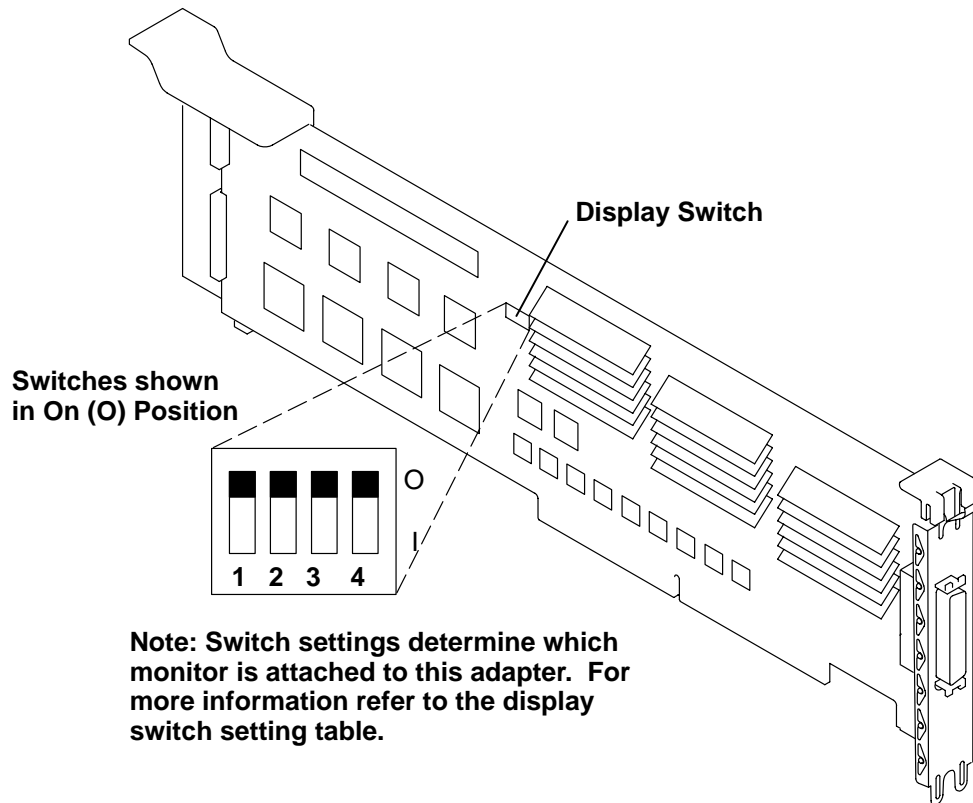

POWER GXT150M Graphics Subsystem Specifications

FRU Number	Base card 66G4162
Resolution	1280 X 1024
Colors	16M (256 active)
Bus architecture	Micro Channel
Busmaster	Yes
Maximum number	2
Connector	13W3 D-shell
Cables	09G3539

POWER GXT150M Graphics Subsystem Display Switch Position Table

Note: In the following table, Display Switch position 1 is Off; Display Switch position 0 is On.

Display Type	Screen Resolution (Non-Interlaced)	Refresh Freq (Hz)	Display Switch 1 2 3 4	Display Cable	Display Mode Switch
6317 Color 6324 Color 6325 Color 9524 Color 9525 Color	1280 x 1024	60	1 0 1 0	51G7826	
1091-051 Color POWERdisplay 16S	1280 x 1024	72	1 1 1 1	09G3589	
5081-16 Color	1280 x 1024	60	1 1 1 1	09G3539	-
6091-16 Color POWERdisplay 16	1280 x 1024	60	1 1 1 1	09G3539	out (1)
		77	1 1 0 1	09G3539	in (2)
6091-19 Color	1280 x 1024	60	1 1 1 1	09G3539	2
		67	1 1 1 0	09G3539	3
6091-19i Color POWERdisplay 19	1280 x 1024	60	1 1 1 1	09G3539	2
		77	1 1 0 1	09G3539	-
POWERdisplay 20	1280 x 1024	60	1 1 1 1	09G3539	2
		77	1 1 0 1	09G3539	-
6091-23 Color	1280 x 1024	60	1 1 1 1	09G3539	-
POWERdisplay 17 Color	1280 x 1024	60	1 1 1 1	09G3539	-
		77	1 1 0 1	09G3539	-
		74	0 1 1 0	09G3539	-
Other Displays	1280 x 1024	60	0 1 1 1	09G3539	-
		74	0 1 1 0	09G3539	-

POWER GXT150M Graphics Subsystem 13W3 13-Position Connector

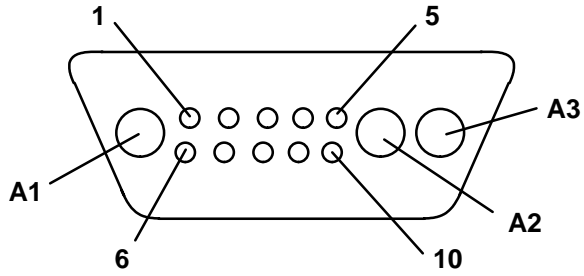

Position	Signal Name
A1	Red
A2	Green
A3	Blue
1	Card RST
2	ROM EM
3	GND
4	VSYNC GND
5	HSYNC
6	CARD EN
7	INTR RST
8	(No Connect)
9	VSYNC
10	HSYNC GND

3. mm S%rĭ Ja%ĕ1-44Adap%árÂ, Di%Â, ad %bL firm%o fOr Mñ%Bo %%

15-p D-Âçĭl (%D-15) %ĭc%ĭr

Dñsp%¾ PĭwEr MagmEn% Sigallg (DPè).

Dñsp%¾ PĭwEr MagmEn%Supĭr%Â Vĭdeo E%c%ĭoi%Â S%çrdA Assĭ%a%o (VSA).

FC(2850) POWER GXT800M 3D Graphics Adapter with Texture Memory (Type 1-Q)

%B rÂĭA%os 1024x76{ a% 60 - 8 %j var%l rârÂç

umár of %ĭĭrs supĭr%d 24-ñ%, 16.7 mĭlo

The POWER GXT800M 3D Graphics Adapter with texture memory is a single card

that provides 3D graphics and texture acceleration.

The adapter provides 3D graphics and texture acceleration. It is a single card that provides 3D graphics and texture acceleration. It is a single card that provides 3D graphics and texture acceleration.

The GXT800M covers three Micro Channel slot positions. It is a single card that provides 3D graphics and texture acceleration.

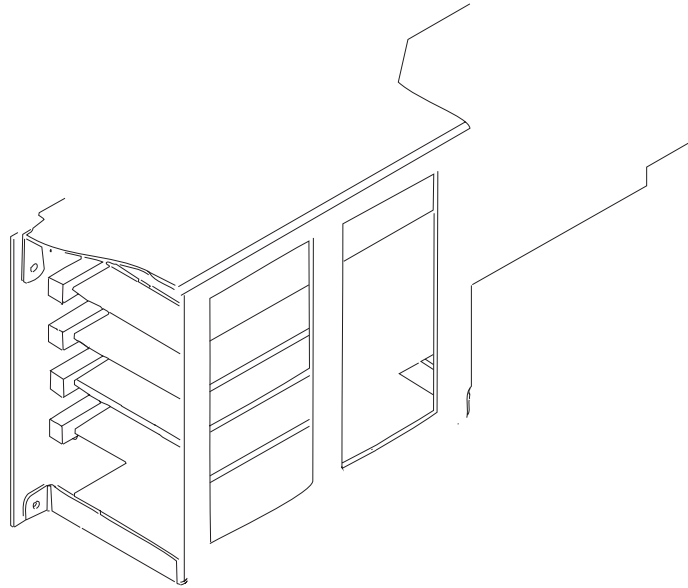

The POWER GXT800M Adapter with Texture Memory Supports:

- 8 and 24 bit double-buffered color
- 8 bit double-buffered alpha
- 8 bit single-buffered overlay
- 8 bits of window ids
- 24 bit Z-buffer
- 4 bit stencil
- OpenGL, PEX, graPHIGS, and GL 3.2 API's
- 3D Acceleration:
 - Depth Buffering
 - Antialiasing
 - Gouraud shading
 - Fog and Atmospheric effects
 - Stencil test
 - Alpha test
 - Blending
 - Dithering.
- Display resolution: 1280x1024 and 1024x768 (includes monitors that comply with ISO 9241, Part 3 Std.)
- Stereo viewing
- The POWER GXT800M with base and texture supports HW acceleration of trilinear mipmapped textures up to 512 x 512.

POWER GXT800M 3D Graphics Adapter 15-pin D-Shell (HD-15) Connector

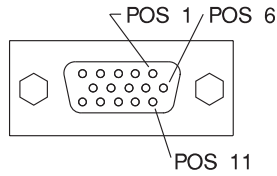

Position	Signal Name
1	RED
2	GREEN
3	BLUE
4	F_MONITOR_ID (2)
5	IOGND (ground)
6	RED_RTN
7	GREEN_RTN
8	BLUE_RTN
9	IOGND (ground)
10	IOGND (ground)
11	F_MONITOR_ID (0)
12	F_MONITOR_ID (1)
13	H_SYNC
14	V_SYNC
15	F_MONITOR_ID (3)

FC (2980) - Ethernet High-Performance LAN Adapter Type (2-1)

This adapter provides a way for the system units to attach to a carrier sense multiple access/collision detection (CSMA/CD) Ethernet network. This adapter attaches to either the IEEE-802.3 type network or the ethernet version 2 network. The adapter has connectors for both 10Base5 (thick) type and 10Base 2 (thin) connections. Only one connector can be used at a time.

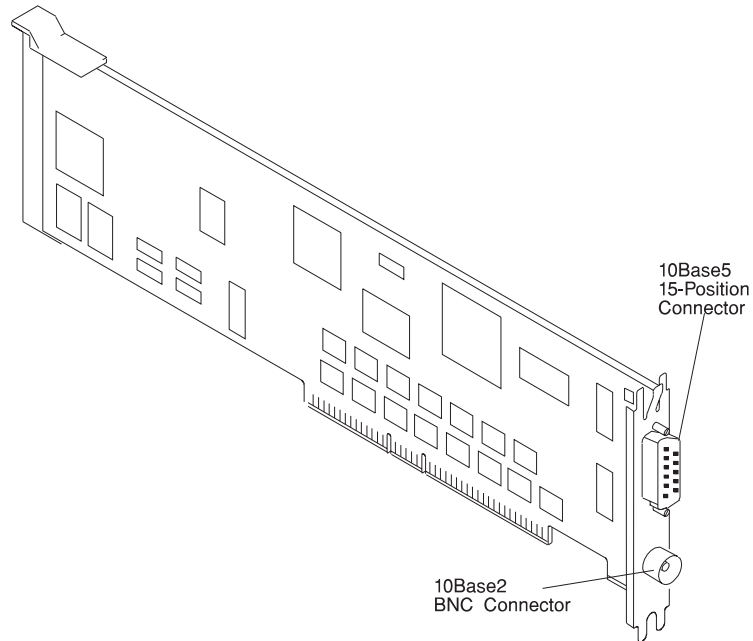

Ethernet High-Performance LAN Adapter Specifications

FRU Number	31F4075
I/O addresses	7280-728A; 7290-729A; 7680-768A 7690-769A; 7A80-7A8A; 7A90-7A9A 7E80-7E8A; 7E90-7E9A
Interrupt levels	9, 10, 11, 12
Bus architecture	Micro Channel
Busmaster	Yes
Maximum number	4
Connectors	BNC coaxial 15-position D-shell
Cables	Customer supplied (Use a Y type connection)
Adapter wrap plugs	15-position D-shell, part number 70F9625 BNC, 25-ohm terminator, part number 70F9626
Tranceivers	Thin, part number 02G7437 Twisted-Pair, part number 02G7431
Tranceiver cable	Adapter-to-transceiver, thick and thin, part number 02G7434
Tranceiver wrap plugs	Thin, part number 02G7433 Twisted-Pair, part number 00G2380

Ethernet High-Performance LAN Adapter 15-Position Connector

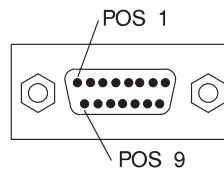

Position	Mnemonic	Signal Name
1	CI-S	Control in circuit-shield
2	CI-A	Control in circuit-A
3	DO-A	Data out circuit-A
4	DI-S	Data in circuit-shield
5	DI-A	Data In circuit-A
6	Vc	Voltage common
7	CO-A	Control out circuit-A
8	CO-S	Control out circuit-shield
9	CI-B	Control in circuit-B
10	DO-B	Data out circuit-B
11	DO-S	Data out circuit-shield
12	DI-B	Data in circuit-B
13	VP	Voltage plus
14	VS	Voltage shield
15	CO-B	Control out-B
Shell	PG	Protective ground (conductive shell)

FC (2970) Token-Ring High-Performance Network Adapter (Type 2-2)

This adapter provides a way for the system units to attach to a token-ring local-area network (LAN). This adapter uses the IEEE-802.5 standard for communications.

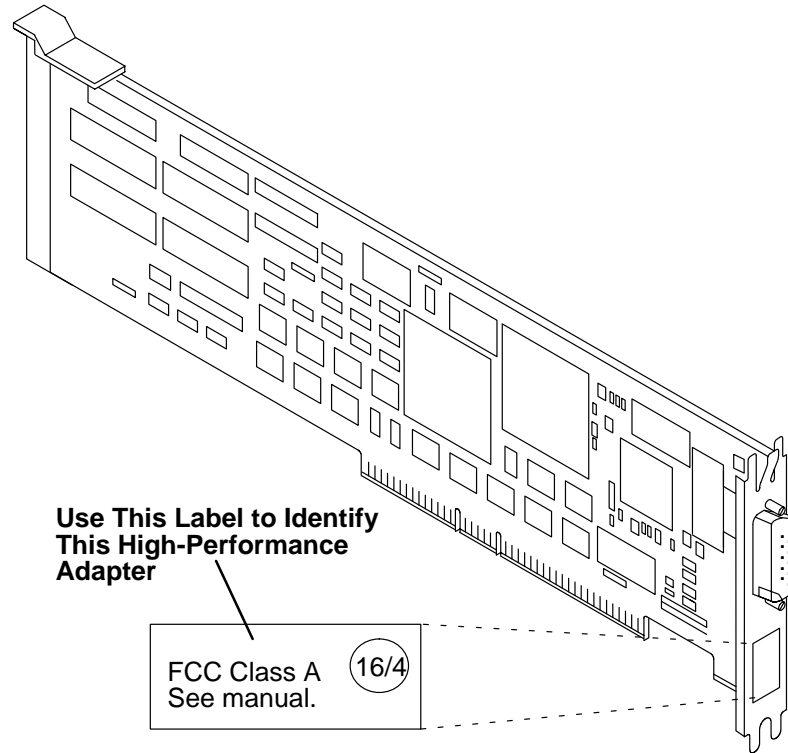

Token-Ring High-Performance Network Adapter Specifications

FRU Number	00G2652
I/O addresses	86A0-86AF 96A0-86AF A6A0-A6AF B6A0-B6AF C6A0-C6AF D6A0-D6AF E6A0-E6AF F6A0-F6AF
Interrupt levels	2, 3, 4, 5, 7, 10, 11, 12
Bit rate	4M bits or 16M bits per second (set by program)
Bus architecture	Micro Channel
Busmaster	Yes
Maximum number	4
Microcode file names	8fc8m.xx.xx 8fc8p.xx.xx 8fcap.xx.xx
Connector	9-position, D-shell
Cables	Token-ring cable, 3.04 m (10 ft.), part number 6339098 Token-ring cable, 6.08 m (20 ft.), part number 53F3930.

Token-Ring High-Performance Network Adapter 9-Position Connector

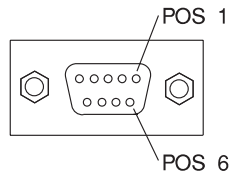

Position	Signal Name
1	Ring In 1 (red)
2	DC Common
3	+5 V dc
4	DC Common
5	Ring Out 2 (black)
6	Ring In 2 (green)
7	DC Common
8	DC Common
9	Ring Out 1 (orange)

FC (2700) 4-Port Multiprotocol Communications Controller (Type 2-3)

This adapter provides a way to attach the system units to several types of synchronous communications networks. The adapter consists of the multiprotocol base card and the multiprotocol interface card. This combination provides four individually-addressable synchronous communications channels.

Each of the four ports can only be attached to and operate with one network type. The software configuration and network connection must match to operate correctly. See Chapter 3, "Cables and Cabling" on page 3-1 for additional information.

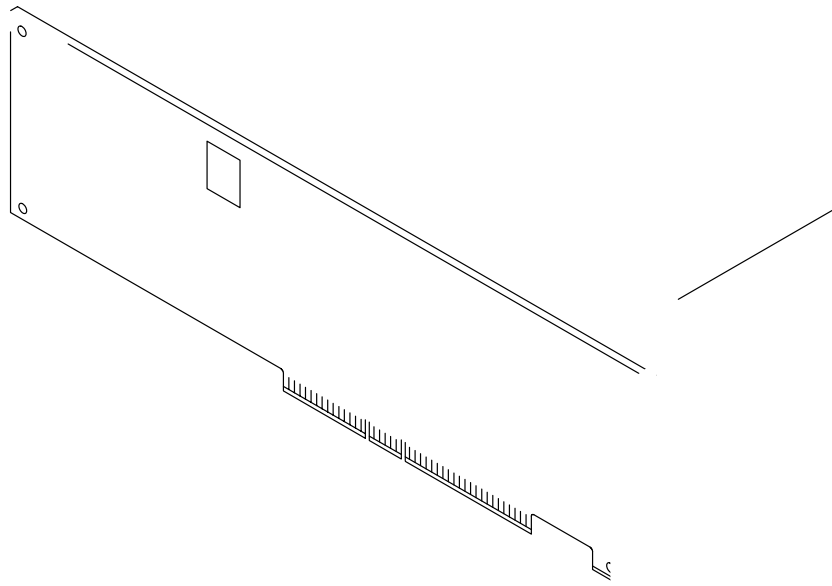

4-Port Multiprotocol Communications Controller 78-Position Connector

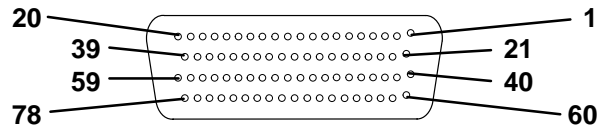

Mnemonic	Signal Name (Type of Interface)	Port 0	Port 1	Port 2	Port 3
-TXD	Transmit Data (EIA232D)	40	04	66	69
-RXD	Receive Data (EIA232D)	02	64	28	31
+RTS	Request To Send (EIA232D, V.35)	01	63	27	30
+CTS	Clear To Send (EIA232D, V.35)	61	25	48	51
SG	Signal Ground	43	07	08	67
+DCD	Data Carrier Detect (EIA232D, V.35)	22	45	09	12
-RCLKIN	Receive Clock (EIA232D)	62	26	10	17
+DTR	Data Terminal Ready (EIA232D, V.35)	60	24	47	50
+DSR	Data Set Ready (EIA232D, V.35)	42	06	68	71
+HRS	Data Rate Selector (EIA232D)	21	44	11	
+RI	Ring Indicator (EIA232D)	03	65	29	32
-TCLKIN	Transmit Clock (EIA232D)	23	56	70	75
-DTECLK	DTE Clock (EIA232D)	15	34	54	73
+TxD (A)	+Transmit Data (V.35)	36	49		
-TxD (B)	-Transmit Data (V.35)	53	14		
+TDATA (A)	+Transmit Data (EIA422A- X.21)	37		13	
-TDATA (B)	-Transmit Data (EIA422A- X.21)	76		52	
+RxD (A)	+Receive Data (V.35, EIA422A- X.21)	19	78	33	
-RxD (B)	-Receive Data (V.35, EIA422A- X.21)	58	35	72	
+TCLK (A)	+Transmit Clock (V.35, EIA422A)	18	39		
-TCLK (B)	-Transmit Clock (V.35, EIA422A)	57	16		
+RCLK (A)	+Receive Clock (V.35, EIA422A- X.21)	38	74		
-RCLK (B)	-Receive clock (V.35, EIA422A- X21)	77	55		
+C (A)	+Control (Port 0, X.21)	20			
-C (B)	-Control (Port 0, X.21)	59			
	Reserved (any port)	05			
	Reserved (any port)	46			
	Reserved (any port)	41			

FC (2960) X.25 Interface Co-Processor/2 (Type 2-4)

This adapter provides a way to attach the system units to a serial network. Use this adapter, the correct software, and the correct cable to communicate on a X.21, V.24, or V.35 network.

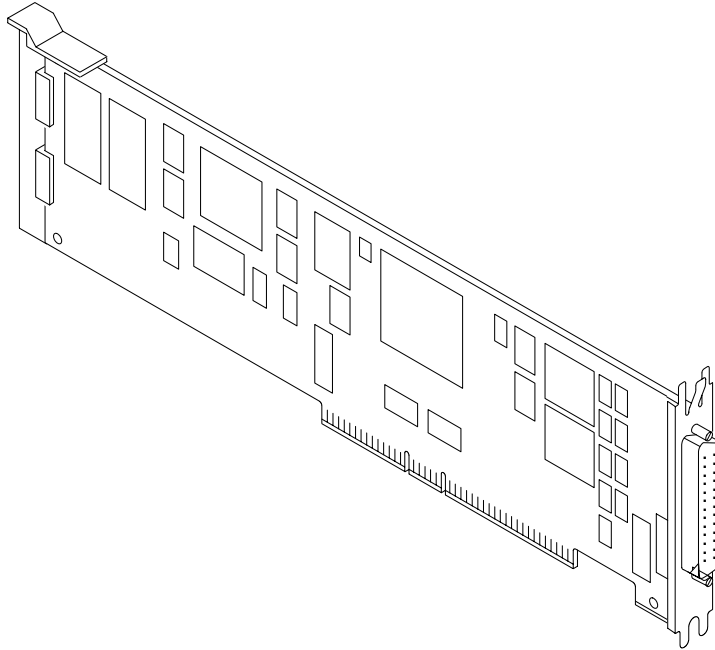

X.25 Interface Co-Processor/2 Specifications

FRU/Option Numbers	Base card 51G9060 Memory DRAM SIP 68X5706
Interrupt levels	3, 4, 7, 9, 10, 11, 12
Bus architecture	Micro Channel
Busmaster	No
Maximum number	4
Microcode file names	f0efd.xx.xx /etc/microcode/icaaim.com (use for 3.1.x releases) /usr/lib/microcode/icaaim.com (use for 3.2.x releases) /etc/asw/x25a.exe
Connector	37-position, D-shell
Wrap plugs	37-position, part number 07F3132/16F1884 X.21, part number 07F3153/16F1890 X.24, part number 07F3163/16F1891 V.35, part number 07F3173/16F1861
Cables	X.25 Attachment Cable - X.21, P/N 07F3151/07F3150 - 3 m X.25 Attachment Cable - X.21, P/N 53F3926/NA - 6 m X.25 Attachment Cable - V.24, P/N 07F3161/07F3160 - 3 m X.25 Attachment Cable - V.24, P/N 53F3927/NA - 6 m X.25 Attachment Cable - V.35, P/N 07F3171/07F3170 - 3 m X.25 Attachment Cable - V.35, P/N 53F3928/NA - 6 m

X.25 Interface Co-Processor/2 37-Position Connector

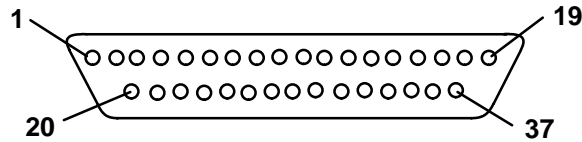

Position	Signal Name [Mnemonic]	Position	Signal Name (Mnemonic)
1	Reserved	21	Remote loopback test [RLBT]
2	Transmitted data [TXD]	22	Call indicate [CI]
3	Received data [RXD]	23	Reserved
4	Request to send [RTS]	24	Transmit clock [TX CLK]
5	Clear to send [CTS]	25	Test indicate [TI]
6	Data set ready [DSR]	26	Receive clock [RX CLK]
7	Signal ground [GND]	27	Local loopback test [LLBT]
8	Carrier detect [CD]	28	Transmitted data (B) [T (B)]
9	Cable ID 0 [ID0]	29	Control (B) [C (B)]
10	Transmitted data (A) [T (A)]	30	Received data (B) [R (B)]
11	Control (A) [C (A)]	31	Indication (B) [I (B)]
12	Received data (A) [R (A)]	32	Transmit clock (B) [S (B)]
13	Indication (A) [I (A)]	33	Reserved
14	Transmit clock (A) [S (A)]	34	Receive clock (A) [RX CLK (A)]
15	Cable ID 1 [ID1]	35	Transmitted data (A) [TXD (A)]
16	Receive clock (B) [RX CLK (B)]	36	Transmit clock (A) [TX CLK (A)]
17	Transmitted data (B) [TXD (B)]	37	Received data (A) [RXD (A)]
18	Transmit clock (B) [TX CLK (B)]		
19	Received data (B) [RXD (B)]		
20	Data terminal ready [DTR]		

**FC (2720) Fiber Distributed Data Interface (FDDI) Single Ring Adapter
(Type 2-6)**

FDDI Single Ring Adapter Specifications	FRU number	81F9003M
Connector	Media Interface Connector (MIC)	
Jumper Cables	Fiber optic, customer-provided, available from dis	
Crossover Cable	81F9012	
Microcode filenames	8ef4m.xx.xxWrap Plug	92F900

FC (2722) Fiber Distributed Data Interface (FDDI) Dual Ring Upgrade Adapter (Type 2-7)

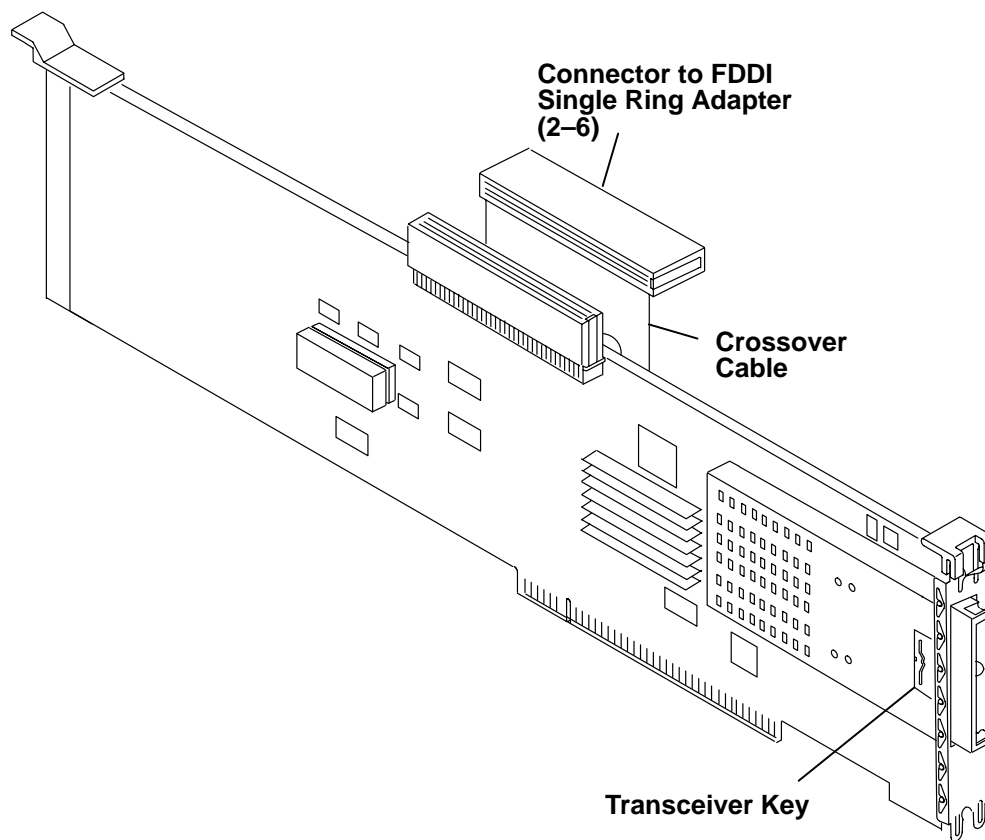

FDDI Dual Ring Upgrade Kit Adapter Specifications

FRU number	81F9014
Maximum number	3 (7013/7016) 2 (7012)
Bus architecture	Micro Channel
Connector	Media Interface Connector (MIC)
Jumper Cables	Fiber optic, customer-provided, available from distributors.
Crossover Cable	81F9012
Microcode filenames	8ef4m.xx.xx fddi.diag
Wrap Plug	92F9003.

FC (7002 or 7004 and 7022) 4-Port EIA-232-C Multiport/2 Adapter (Type 2-C)

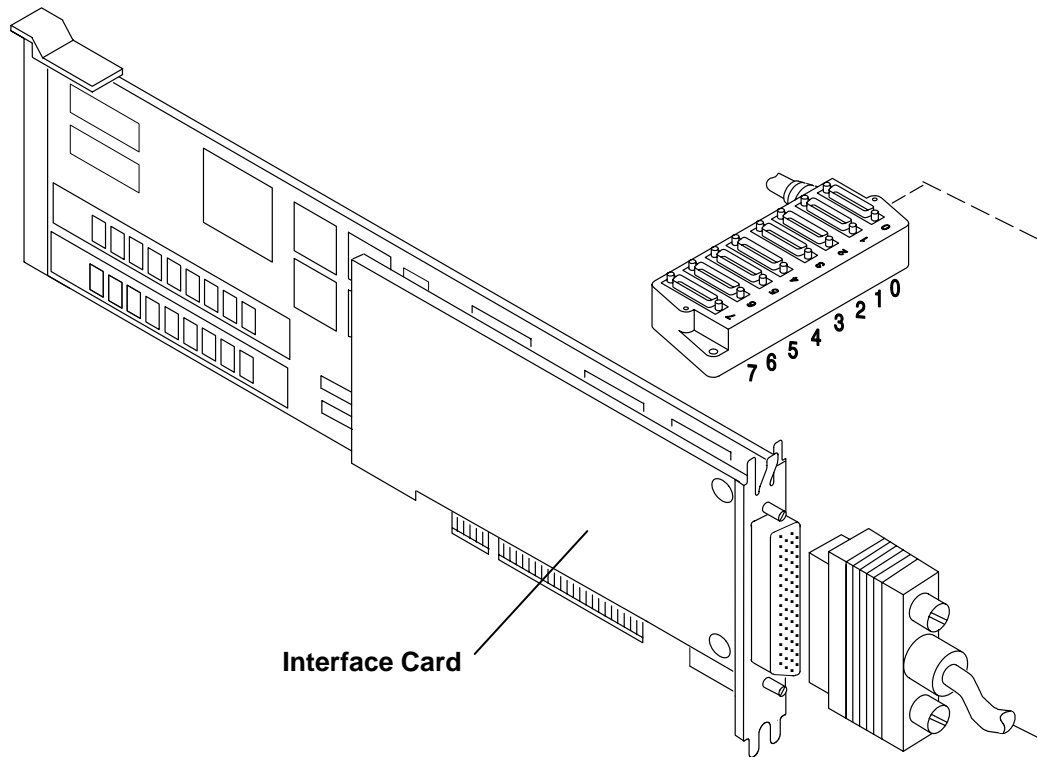

4-Port EIA-232-C Multiport/2 Adapter Specifications

FRU/Option Numbers	0 Memory Base card (512 KB Label), 09F1888/NA 0 Memory Base card (1 MB Label), 09F1962/NA Base card (512 KB), 85F0255/09F1897 Base card (1 MB), 16F1824/16F1820 Interface card (order separately), 91F7976/09F1955 256 KB memory module (512 KB card), 16F2267 512 KB memory module (1 MB card), 04G5834
Bus architecture	Micro Channel
I/O addresses	02A0 - 1EA7
Interrupt levels	3, 4, 7, 9, 10, 11, 12
Maximum number	8
Microcode filename	/usr/lib/microcode/icaaim.com (use for releases 3.2.x)
Connector	78-position, D-shell, female
Wrap plugs	78-position, part number 09F1803/16F2478 25-position, ports 0 and 1, 6425494 25-position, ports 2 through 3, 09F1799
Cables	4P/8P Multiport/2 interface cable, 00F5524/00F5531

4-Port EIA-232-C Multiport/2 Adapter 78-Position and 25-Position Connectors

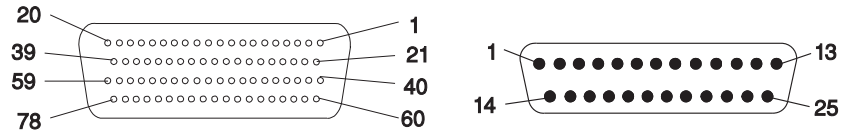

Mnemonic	Port 0	Port 1	Port 2	Port 3	25-Position Connector
TxD	40	04	66	69	02/BA-103
RxD	02	64	28	31	03/BB-104
RTS	01	63	27	30	04/CA-105
CTS	61	25	48	51	05/CB-106
DTECLK	41	05	--	--	24/DA-113
SG	07	08	11	43	07/AB-102
DCD	22	45	09	12	08/CF-109
RxCLKIN	62	26	--	--	17/DD-115
DTR	60	24	47	50	20/CD-108.2
DSR	42	06	68	71	06/CC-107
HRS	21	44	--	--	23/CH-111
RI	03	65	29	32	22/CE-125
TxCLKIN	23	46	--	--	15/DB-114

**FC (7002 or 7004 and 7026) 8-Port EIA-232-C Multiport/2 Adapter
(Type 2-D)**

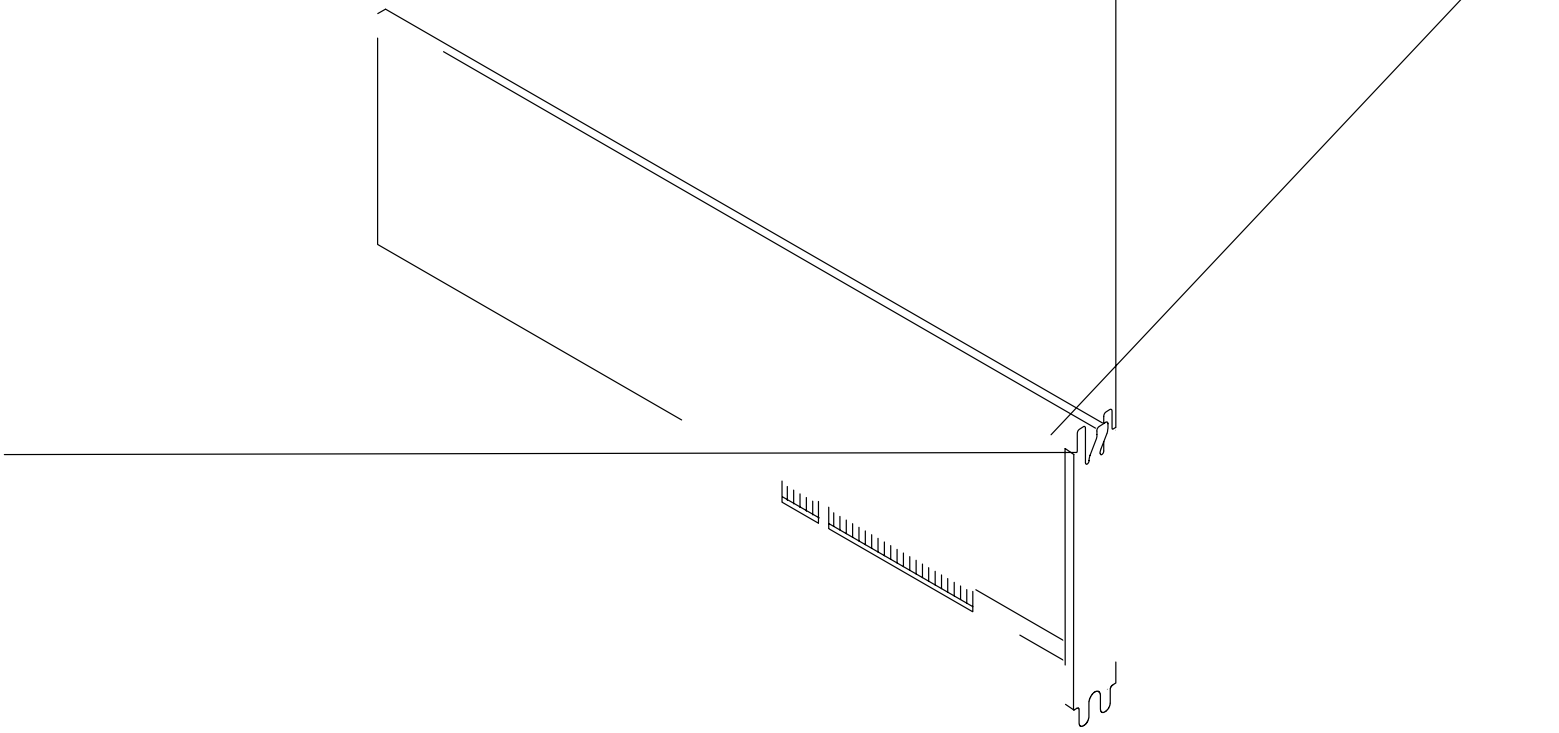

8-Port EIA-232-C Multiport/2 Adapter 78-Position and 25-Position Connectors

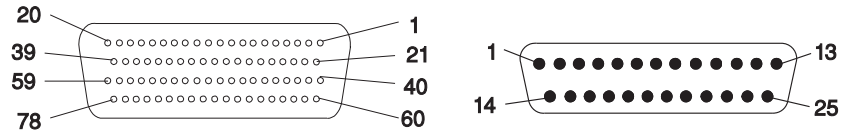

Mnemonic	Port 0	Port 1	Port 2	Port 3	Port 4	Port 5	Port 6	Port 7	25-Position Connector
TxD	40	04	66	69	73	55	76	58	02/BA-103
RxD	02	64	28	31	54	75	57	78	03/BB-104
RTS	01	63	27	30	34	16	37	19	04/CA-105
CTS	61	25	48	51	15	36	18	39	05/CB-106
DTECLK	41	05	--	--	--	--	--	--	24/DA-113
SG	07	08	11	43	67	70	67	70	07/AB-102
DCD	22	45	09	12	74	56	77	59	08/CF-109
RxCLKIN	62	26	--	--	--	--	--	--	17/DD-115
DTR	60	24	47	50	35	17	38	20	20/CD-108.2
DSR	42	06	68	71	72	33	53	14	06/CC-107
HRS	21	44	--	--	--	--	--	--	23/CH-111
RI	03	65	29	32	49	52	10	13	22/CE-125
TxCLKIN	23	46	--	--	--	--	--	--	15/DB-114

FC (7002 or 7004 and 7024) 6-Port Synchronous EIA-232-C Multiport/2 Adapter (Type 2-E)

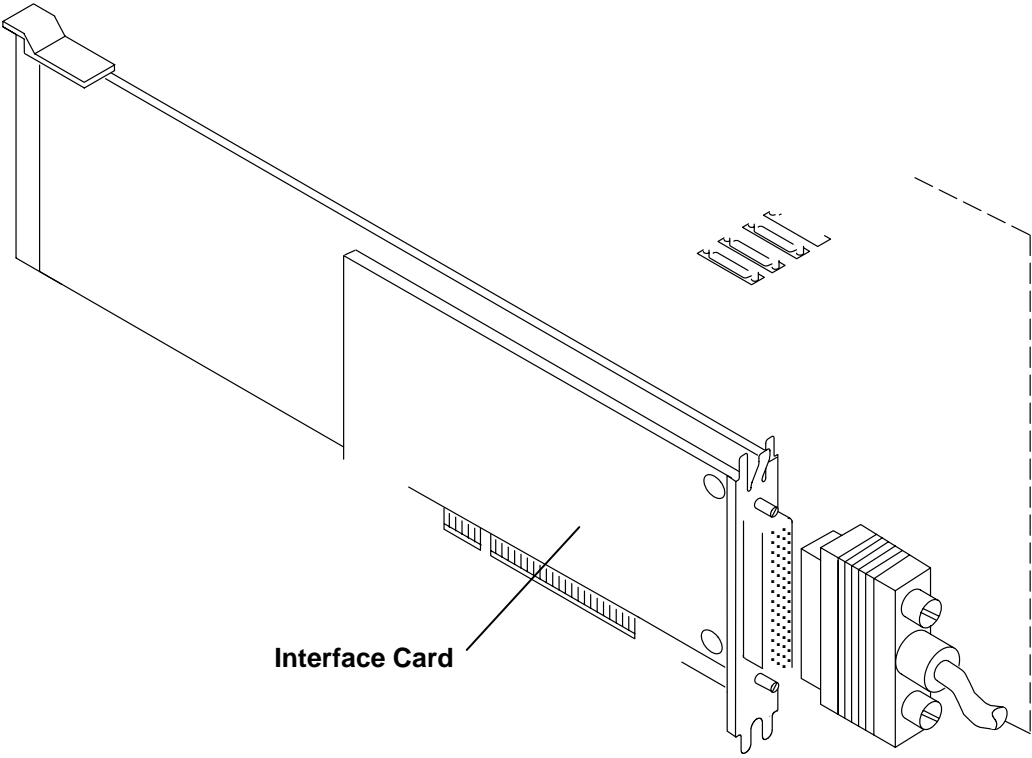

6-Port Synchronous EIA-232-C Multiport/2 Adapter 78-Position and 25-Position Connectors

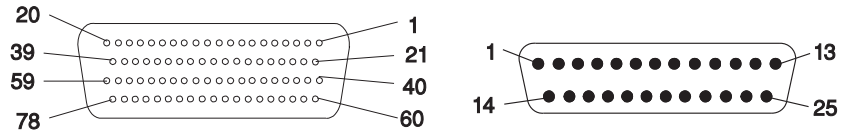

Mnemonic	Port 0	Port 1	Port 2	Port 3	Port 4	Port 5	25-Position Connector
TxD	40	04					
RxD	02	64					
RTS	01						
CTS	61						

FC (7002 or 7004 and 7030) 4-Port EIA-232-C/4-Port EIA-422-A Multiport/2 Adapter (Type 2-F)

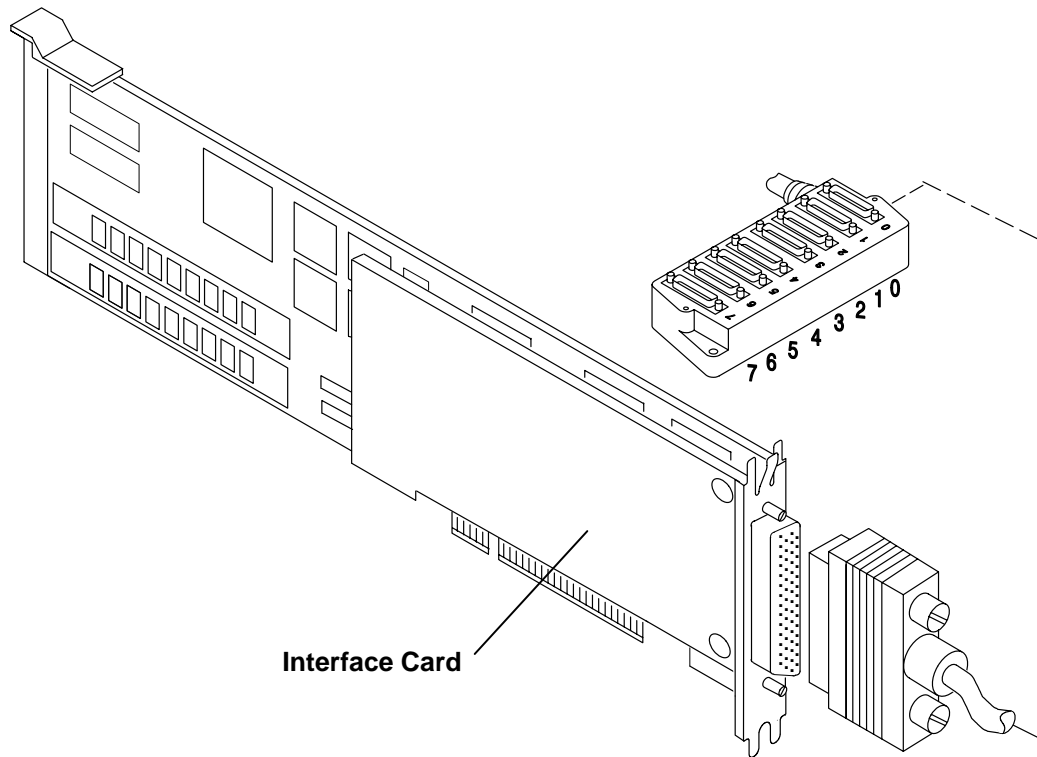

4-Port EIA-232-C/4-Port EIA-422-A Multiport/2 Adapter Specifications

FRU/Option Numbers	0 Memory Base card (512 KB Label), 09F1888/NA 0 Memory Base card (1 MB Label), 09F1962/NA Base card (512 KB), 85F0255/09F1897 Base card (1 MB), 16F1824/16F1820 Interface card (order separately), 91F7966/09F1958 256 KB memory module (512 KB card), 16F2267 512 KB memory module (1 MB card), 04G5834
Bus architecture	Micro Channel
I/O addresses	02A0 - 1EA7
Interrupt levels	3, 4, 7, 9, 10, 11, 12
Maximum number	8
Microcode file name	/usr/lib/microcode/icaaim.com (use on releases 3.2.x)
Connector	78-position, D-shell, female
Wrap plugs	78-position, part number 09F1803/16F2478 25-position, ports 0 and 1, 6425494 25-position, ports 2 through 7, 09F1799
Cables	4P/8P Multiport/2 interface cable, 00F5524/00F5531

4-Port EIA-232-C/4-Port EIA-422-A Multiport/2 Adapter 78-Position and 25-Position Connectors (EIA-232-C Assignments)

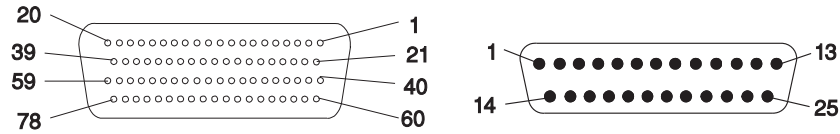

Mnemonic	Port 0	Port 1	Port 2	Port 3	25-Position Connector
TxD	40	04	66	69	02/BA-103
RxD	02	64	28	31	03/BB-104
RTS	01	63	27	30	04/CA-105
CTS	61	25	48	51	05/CB-106
DTECLK	41	05	--	--	24/DA-113
SG	43	07	08	67	07/AB-102
DCD	22	45	09	12	08/CF-109
RxCLKIN	62	26	--	--	17/DD-115
DTR	60	24	47	50	20/CD-108.2
DSR	42	06	68	71	06/CC-107
HRS	21	44	--	--	23/CH-111
RI	03	65	29	32	22/CE-125
TxCLKIN	23	46	--	--	15/DB-114

4-Port EIA-232-C/4-Port EIA-422-A Multiport/2 Adapter 78-Position and 25-Position Connectors (EIA-422-A Assignments)

Mnemonic	Port 4	Port 5	Port 6	Port 7	25-Position Connector
TxD+	73	55	76	58	02/TXA
TxD-	34	16	37	19	04/TXB
RxD+	54	75	57	78	03/RXA
RxD-	15	36	18	39	05/RXB
SG	11	70	--	--	07

FC (7002 or 7004 and 7028) 8-Port EIA-422-A Multiport/2 Adapter (Type 2-G)

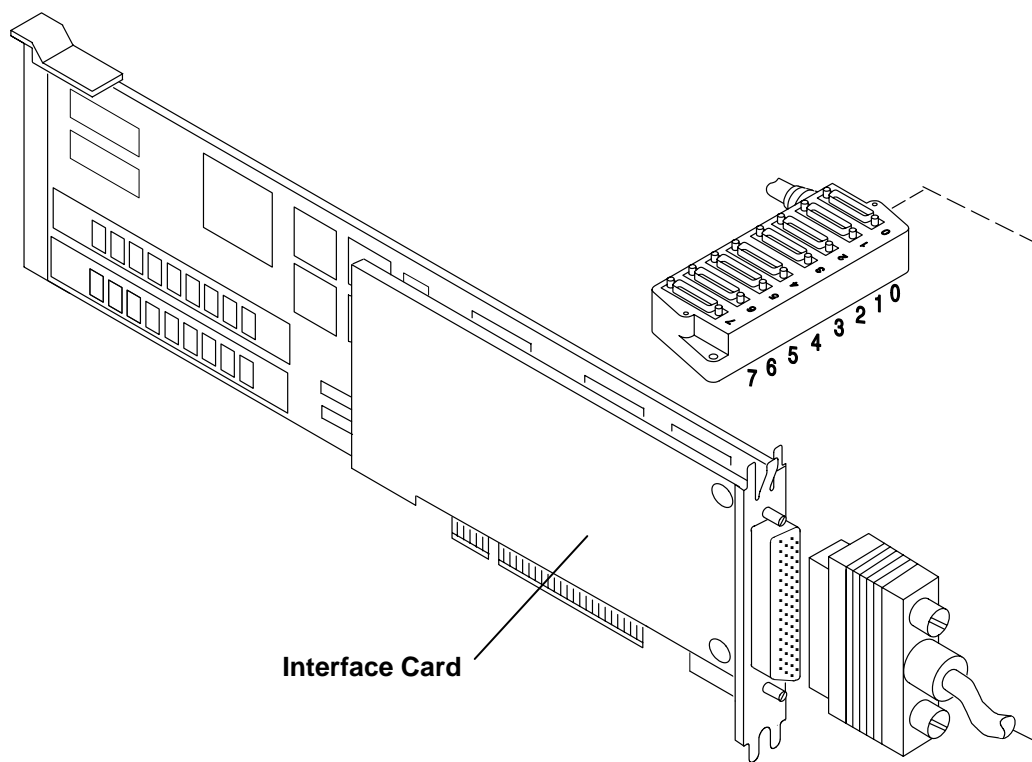

8-Port EIA-422-A Multiport/2 Adapter Specifications

FRU/Option Numbers	0 Memory Base card (512 KB Label), 09F1888/NA 0 Memory Base card (1 MB Label), 09F1962/NA Base card (512 KB), 85F0255/09F1897 Base card (1 MB), 16F1824/16F1820 Interface card (order separately), 15F8858/15F8852 256 KB memory module (512 KB card), 16F2267 512 KB memory module (1 MB card), 04G5834
Bus architecture	Micro Channel
I/O addresses	02A0 - 1EA7
Interrupt levels	3, 4, 7, 9, 10, 11, 12
Maximum number	8
Microcode file name	/usr/lib/microcode/icaaim.com (use on releases 3.2.x)
Connector	78-position, D-shell, female
Wrap plugs	78-position, part number 09F1803/16F2478 25-position, ports 2 through 7, 09F1799 25-position, ports 0 and 1, 6425494
Cables	4P/8P Multiport/2 interface cable, 00F5524/00F5531

8-Port EIA-422-A Multiport/2 Adapter 78-Position and 25-Position Connectors

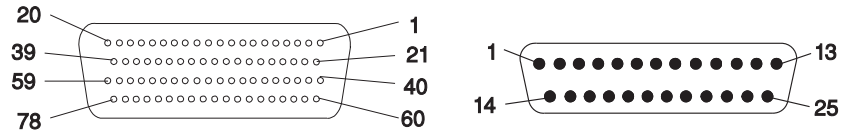

Mnemonic	Port 0	Port 1	Port 2	Port 3	Port 4	Port 5	Port 6	Port 7	25-Position Connector
TxD+	40	04	66	69	73	55	76	58	02/TxA
TxD-	01	63	27	30	34	16	37	19	04/TxB
TxCLK+	21	--	--	--	--	--	--	--	23/TxCLKA
TxCLK-	41	--	--	--	--	--	--	--	24TxCLKB
RxD+	02	64	28	31	54	75	57	78	03/RxA
RxD-	61	25	48	51	15	36	18	39	05/RxB
RxCLK+	03	--	--	--	--	--	--	--	22/RxCLKA
RxCLK-	62	--	--	--	--	--	--	--	17/RxCLKB
SG	43	07	08	67	11	70	--	--	07/GRD

FC (7006 or 7008 and 7042) 8-Port EIA-232-D Portmaster Adapter/A (Type 2-H)

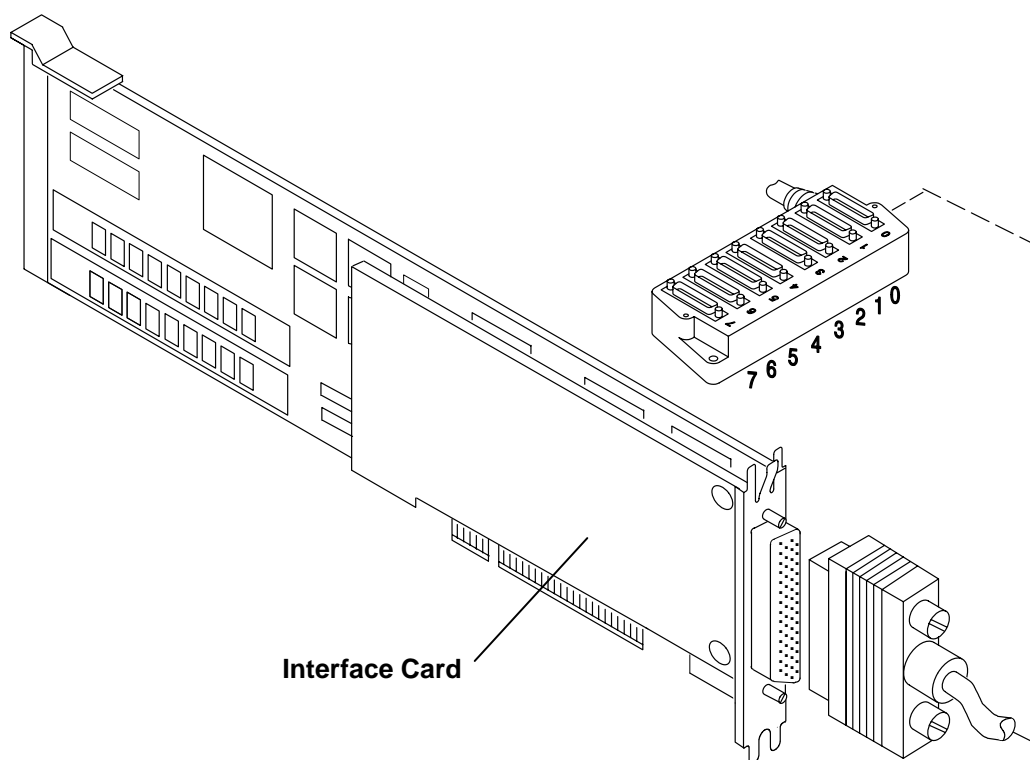

8-Port EIA-232-D Portmaster Adapter/A Specifications

FRU/Option Numbers	Base card (0MB), 53F2603/NA 1 MB Base card, 53F2660/53F2604 2 MB Base card, 53F2664/53F2607 1 MB Memory SIMM, 53F2662 2 MB Memory SIMM, 53F2666 Interface card (order separately), 53F2612/53F2610
Bus architecture	Micro Channel
I/O addresses	02A0 - 1EA7
Interrupt levels	3, 4, 7, 9, 10, 11, 12
Busmaster	Set to No at power on; optionally set to Yes by customer's program
Maximum number	8
Connector	100-position, D-shell, female
Wrap plugs	100-position, part number 68F7208/15F8848 25-position, ports 0 - 7, 33F8985
Cables	8P Portmaster interface cable, 33F8962/53F2619

8-Port EIA-232-D Portmaster Adapter/A 100-Position and 25-Position Connectors

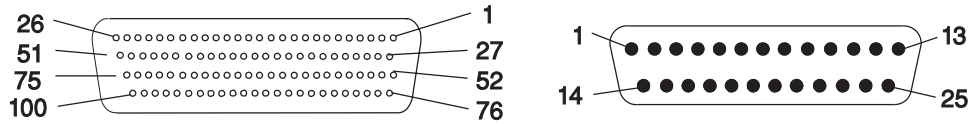

Mnemonic	I/O	Port 0	Port 1	Port 2	Port 3	Port 4	Port 5	Port 6	Port 7	25-Position Connector
TxD	O	51	54	07	10	13	16	94	48	02/BA
RxD		02	05	83	86	89	92	46	74	03/BB
RTS	O	01	04	82	85	88	91	45	73	04/CA
CTS		77	80	34	37	40	43	71	24	05/CB
DCD		28	31	59	62	65	68	21	99	08/CF
DTR	O	76	79	33	36	39	42	70	23	20/CD
DSR		53	56	09	12	15	18	96	50	06/CC
HRS		27	30	58	61	64	67	20	98	23/CI
RI		03	06	84	87	90	93	47	75	22/CE
TxCLKIN		29	32	60	63	66	69	22	100	15/DB
TxCLK	O	52	55	08	11	14	17	95	49	24/DA
RxCLK		78	81	35	38	41	44	72	25	17/DD
SGND	--	19	19	26	26	57	57	97	97	07/AB
FGND	Cable Shield									01/AA

FC (7006 or 7008 and 7044) 8-Port EIA-422-A Portmaster Adapter/A (Type 2-I)

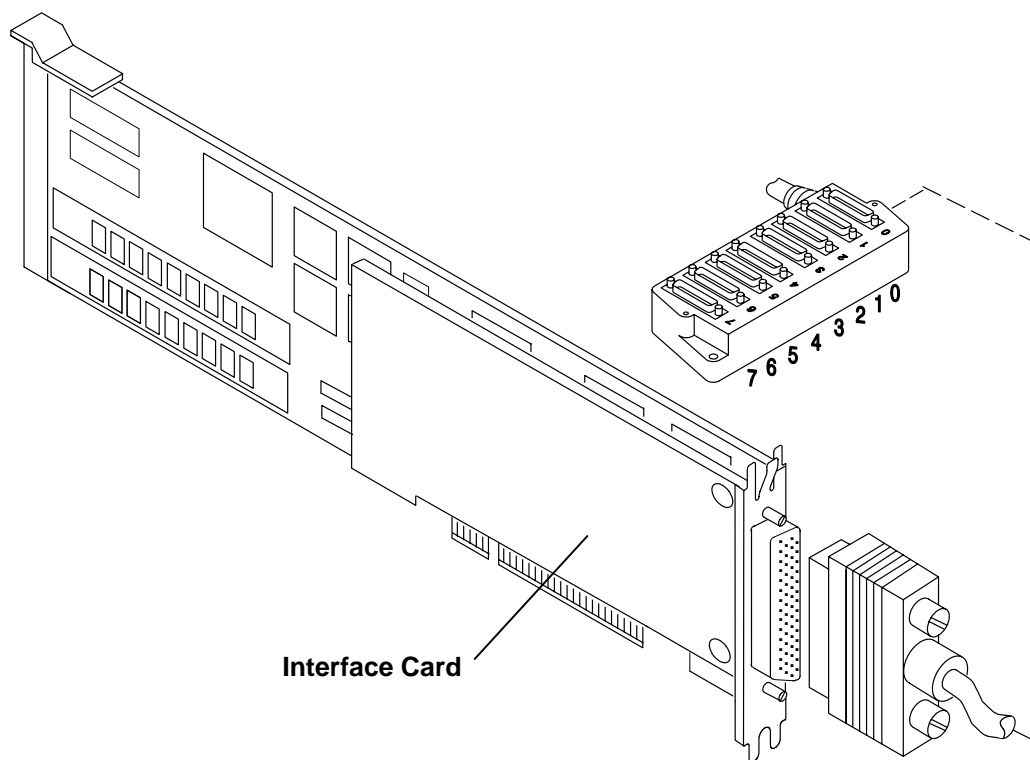

8-Port EIA-422-A Portmaster Adapter/A Specifications

FRU/Option Numbers	Base card (0 MB), 53F2603/NA 1 MB Base card, 53F2660/53F2604 2 MB Base card, 53F2664/53F2607 1 MB Memory SIMM, 53F2662 2 MB Memory SIMM, 53F2666 Interface card (order separately), 53F2615/53F2613
Bus architecture	Micro Channel
I/O addresses	02A0 - 1EA7
Interrupt levels	3, 4, 7, 9, 10, 11, 12
Busmaster	Set to No at power on; optionally set to Yes by customer's program
Maximum number	8
Microcode Filename	/usr/lib/microcode/icarcm.com
Connector	100-position, D-shell, female
Wrap plugs	100-position, part number 68F7208/15F8848 25-position, ports 0 - 7, 33F8964
Cables	8P Portmaster interface cable, 33F8962/53F2619

19

26

57

97

**FC (7006 or 7008 and 7046) 6-Port V.35 Portmaster Adapter/A
(Type 2-J)**

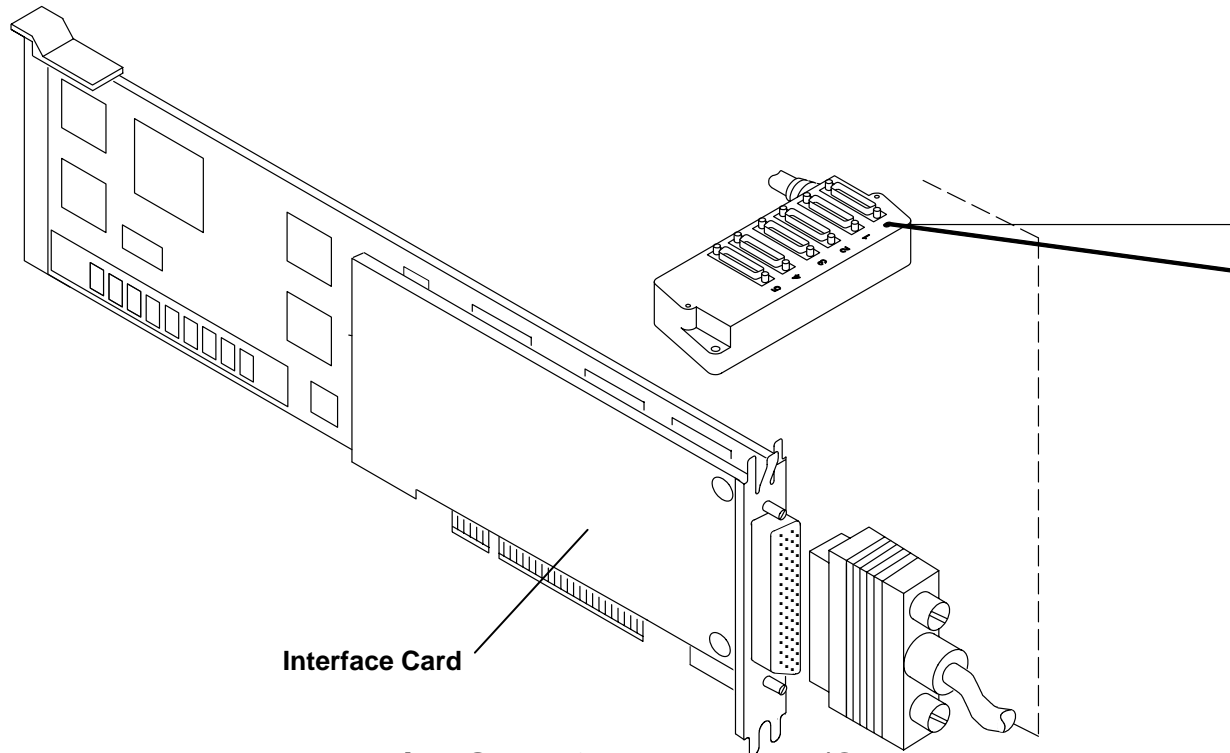

6-Port V.35 Portmaster Adapter/A Specifications FRU/Option Numbers

6-Port V.35 Portmaster Adapter/A 100-Position and 25-Position Connectors

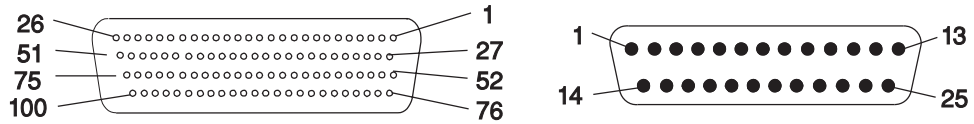

Mnemonic	I/O	Port 0	Port 1	Port 2	Port 3	Port 4	Port 5	25-Position Connector
TxDA	O	94	21	47	71	72	23	02
TxDB	O	70	46	22	95	96	48	14
RxDA		08	54	58	29	28	57	03
RxDB		33	78	82	04	03	81	16
TxCA IN		76	06	77	56	27	55	15
TxCB IN		52	31	53	80	02	79	12
RxCA		20	41	38	19	32	30	17
RxCB		45	16	13	44	07	05	09
TxCA OUT	O	24	73	98	25	99	26	24
TxCB OUT	O	49	97	74	50	75	51	11
RTS	O	42	43	92	93	37	39	04
CTS		15	65	86	87	59	09	05
DCD		89	40	62	61	35	84	08
DTR	O	18	91	69	68	14	12	20
DSR		66	90	88	64	60	85	06
SGND	--	34	17	63	67	01	83	07
FGND		--	100	Shield				01

FC (7006 or 7008 and 7048) 6-Port X.21 Portmaster Adapter/A (Type 2-K)

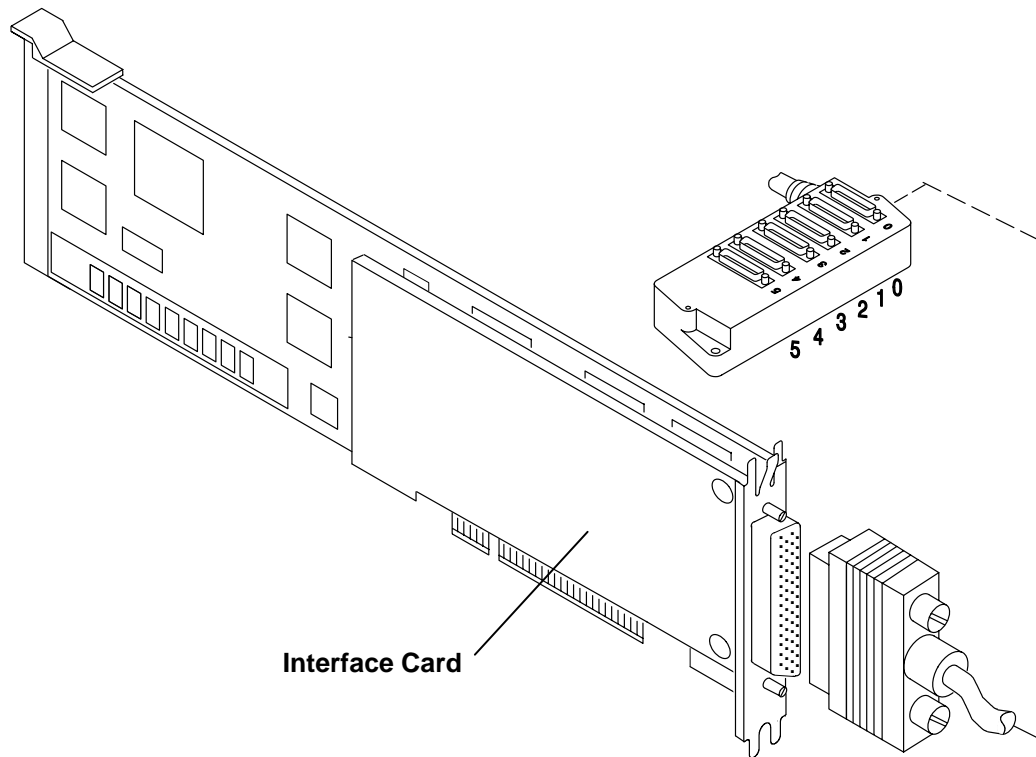

6-Port X.21 Portmaster Adapter/A Specifications

FRU/Option Numbers	Base card (OMB), 53F2603/NA 1 MB Base card, 53F2660/53F2604 2 MB Base card, 53F2664/53F2607 1 MB Memory SIMM, 53F2662 2 MB Memory SIMM, 53F2666 Interface card (order separately), 04G5500/72F0176
Bus architecture	Micro Channel
I/O addresses	02A0 - 1EA7
Interrupt levels	3, 4, 7, 9, 10, 11, 12
Busmaster	Set to No at power on; optionally set to Yes by customer's program
Maximum number	8
Microcode Filename	/usr/lib/microcode/icarcm.com
Connector	78-position, D-shell, female
Wrap plugs	78-position, part number 85F0205/04G1972 25-position, ports 0 - 5, 85F0206/04G1973
Cables	6P X.21 Portmaster interface, 04G1974/05F2028

6-Port X.21 Portmaster Adapter/A 78-Position and 25-Position Connectors

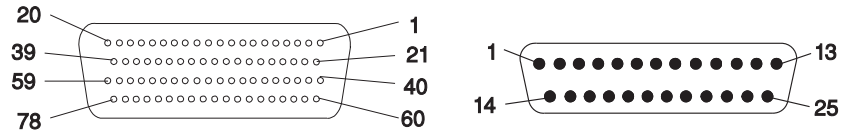

Mnemonic	I/O	Port 0	Port 1	Port 2	Port 3	Port 4	Port 5	25-Position Connector
T(A)	O	40	04	66	69	73	55	02
T(B)	O	41	05	19	20	10	13	24
R(A)		02	64	28	31	54	75	03
R(B)		62	26	57	77	18	53	17
C(A)	O	01	63	27	30	34	16	04
C(B)	O	60	24	47	50	35	17	20
I(A)		61	25	48	51	15	36	05
I(B)		42	06	68	71	72	33	06
X(A)	O	22	45	09	12	74	56	08
X(B)	O	03	65	29	32	49	52	22
S(A)		23	46	78	59	39	14	15
S(B)		21	44	76	37	38	58	23
SG	--	43	07	08	67	11	70	07

FC (2959) Multiprotocol Adapter/A (MP/A) (Type 2-P)

There are two types of Multiprotocol Adapter/A. This one is the single port.

The Multiprotocol Adapter/A provides the System with one-port Synchronous Data Link Control (SDLC) Connection to a SDLC protocol communications network.

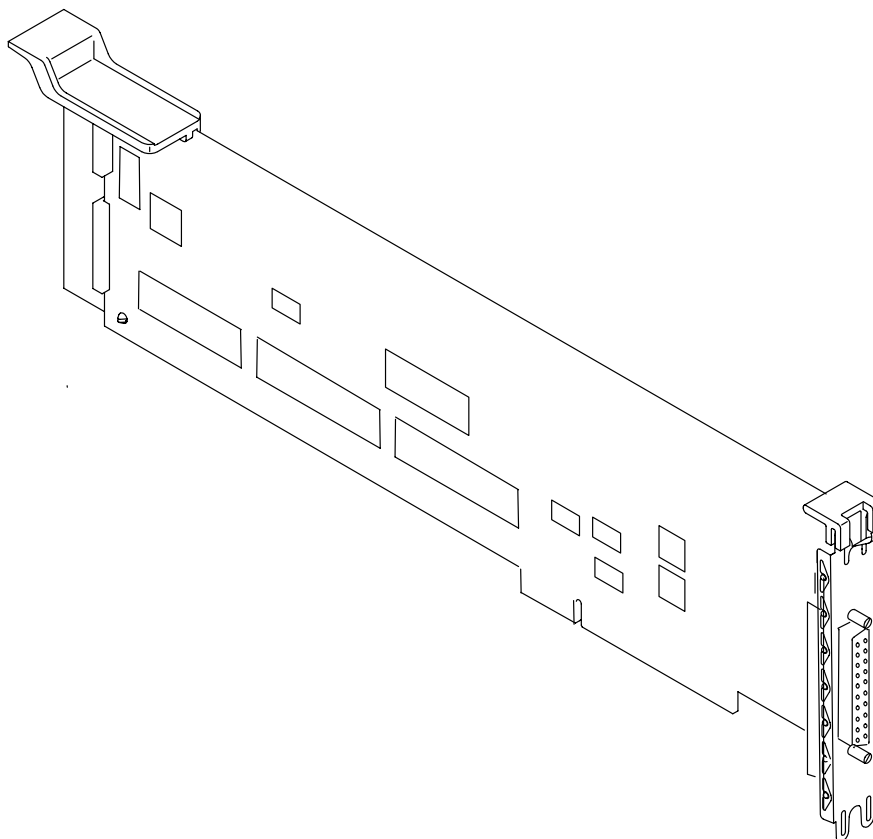

Multiprotocol Adapter/A Specifications

FRU Number	43G0656 part number
I/O addresses	0380 - 0390 or 03A0 - 03B0
Interrupt levels	3 and 4 are used on each installed card
Bus architecture	Micro Channel
Busmaster	No
Maximum number	1
POS ID	FFDE
Connector	25-position, D-shell
Wrap plug	25-position, EIA-232D, part number 62X1083 or 72X8546
Cable	EIA-232D serial cable, part number 1502067, 71F0165 or 6323741

Multiprotocol Adapter/A 25-Position Connector

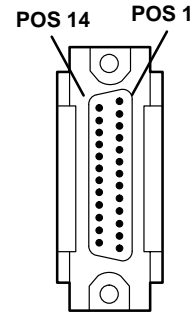
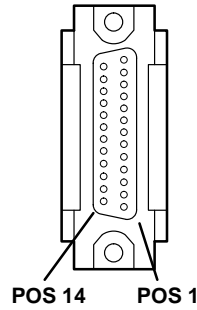

System End Connector	Signal	Device End Connector
Socket (Female)		Pin (Male)
Shell	Shield Ground	1, Shell
2	TxD	2
3	RxD	3
4	RTS	4
5	CTS	5
6	DSR	6
7	Signal Ground	7
8	CD	8
15	Tx CLK	15
17	Rx CLK	17
20	DTR	20
22	RI	22
23	HRS	23

FC (2724) FDDI-Fiber Single Ring Adapter (Type 2-R)

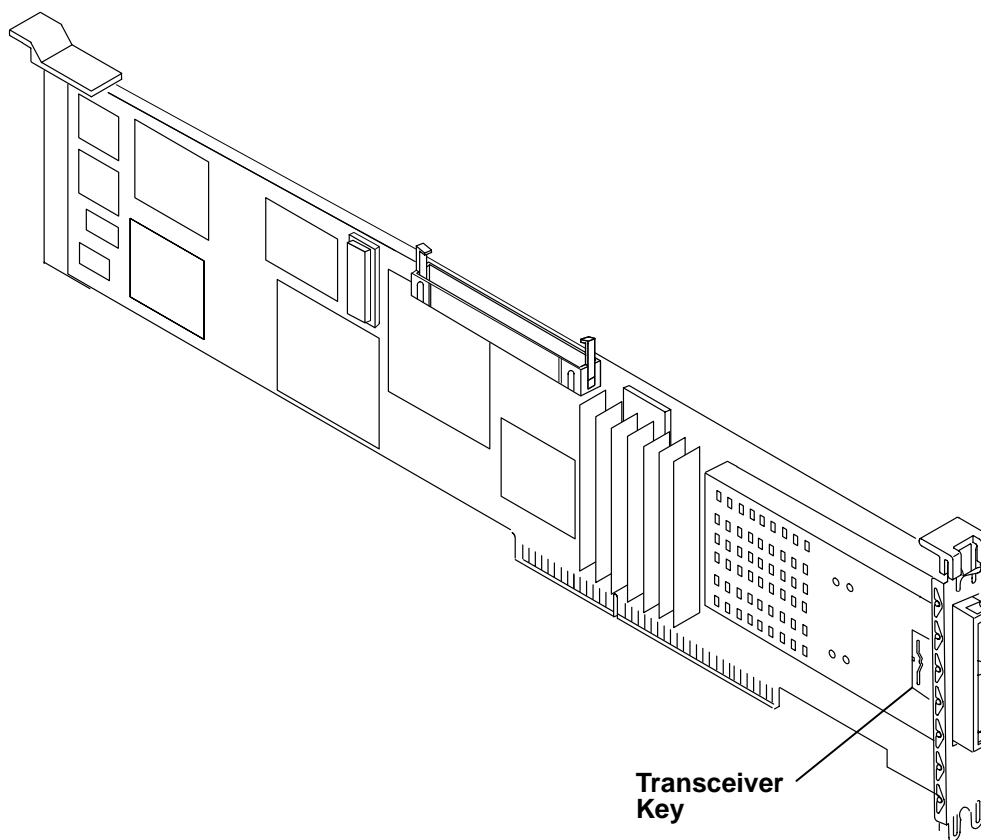

FDDI-Fiber Single Ring Adapter Specifications

FRU number	65G1879
Maximum number	2 (7011) 4 (7012) 6 (7013/7016)
Bus architecture	Micro Channel
Connector	Media Interface Connector (MIC)
Jumper Cables	Fiber optic, customer-provided, available from distributors.
Microcode filenames	8ef4m.xx.xx fddi.diag
Wrap Plug	81F9016

FC (2723) FDDI-Fiber Dual Ring Upgrade Kit Adapter (Type 2-S)

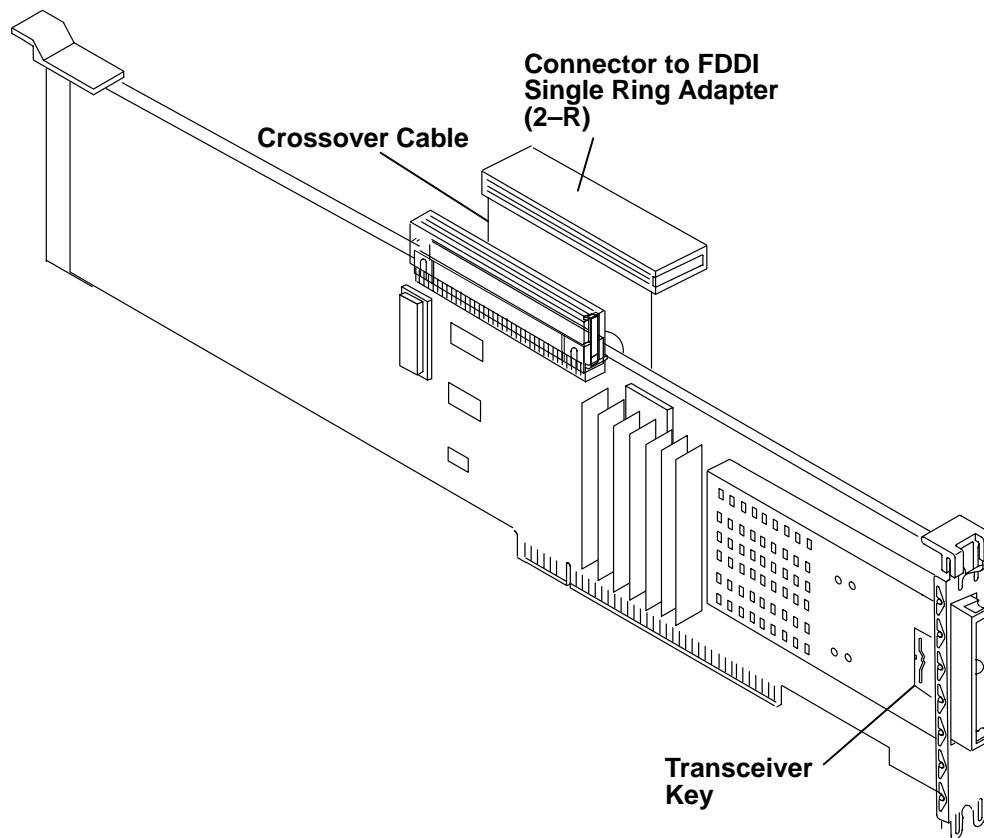

FDDI-Fiber Dual Ring Upgrade Kit Adapter Specifications

FRU number	43G0856
Maximum number	1 (7011) 2 (7012) 3 (7013/7016)
Bus architecture	Micro Channel
Connector	Media Interface Connector (MIC)
Jumper Cables	Fiber optic, customer-provided, available from distributors.
Crossover Cable	93F1162
Wrap Plug	81F9016

Note: The cross over cable is too short if the two dual ring adapters are in some slots. If this is the case, move the adapters to different slots.

FC (2725) FDDI-STP Single Ring Adapter (Type 2-T)

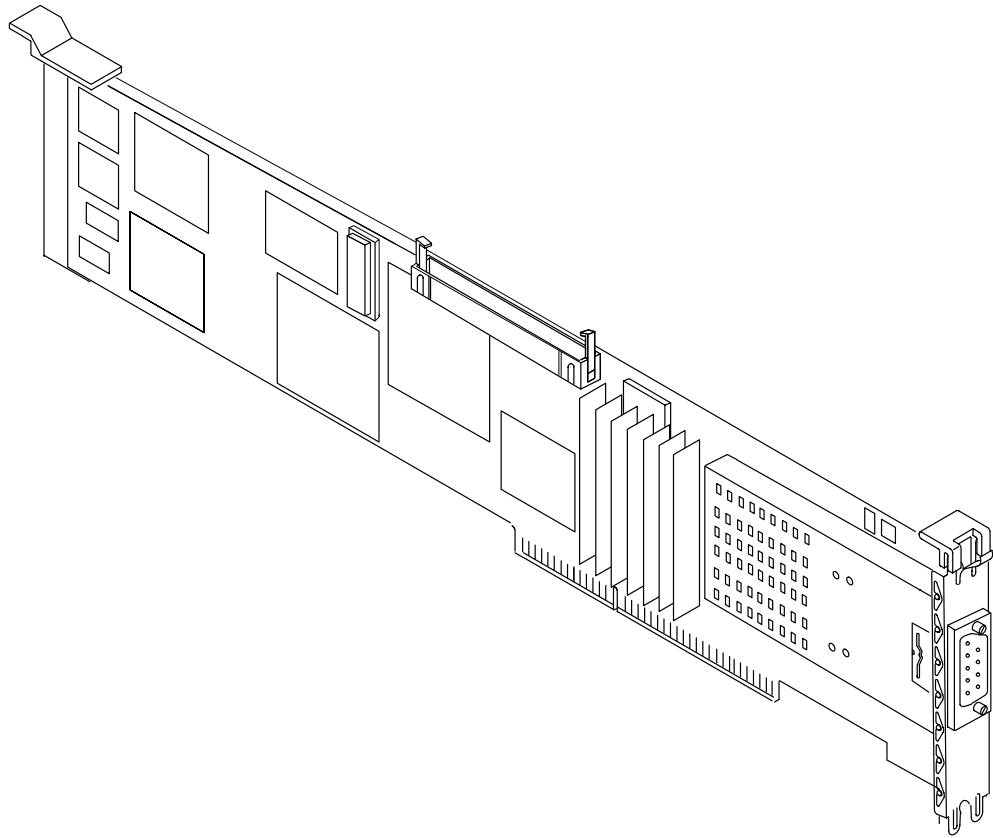

FDDI-STP Single Ring Adapter Specifications

FRU number	65G1878
Maximum number	2 (7011) 4 (7012) 6 (7013/7016)
Bus architecture	Micro Channel
Connector	9-pin D-shell
Jumper Cables	FDDI-STP adapter cable, 33G2761
Microcode filenames	8ef f(i)èçĭ, ``ĭ, %])

FDDI-STP Single Ring Adapter 9-Position Connector

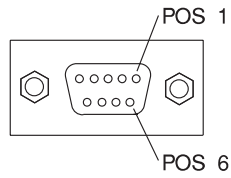

Position	Signal Name
1	Receive +
2	Not Used
3	Not Used
4	Not Used
5	Transmit +
6	Receive -
7	Not Used
8	Not Used
9	Transmit -

FC (2726) FDDI-STP Dual Ring Upgrade Kit Adapter (Type 2-U)

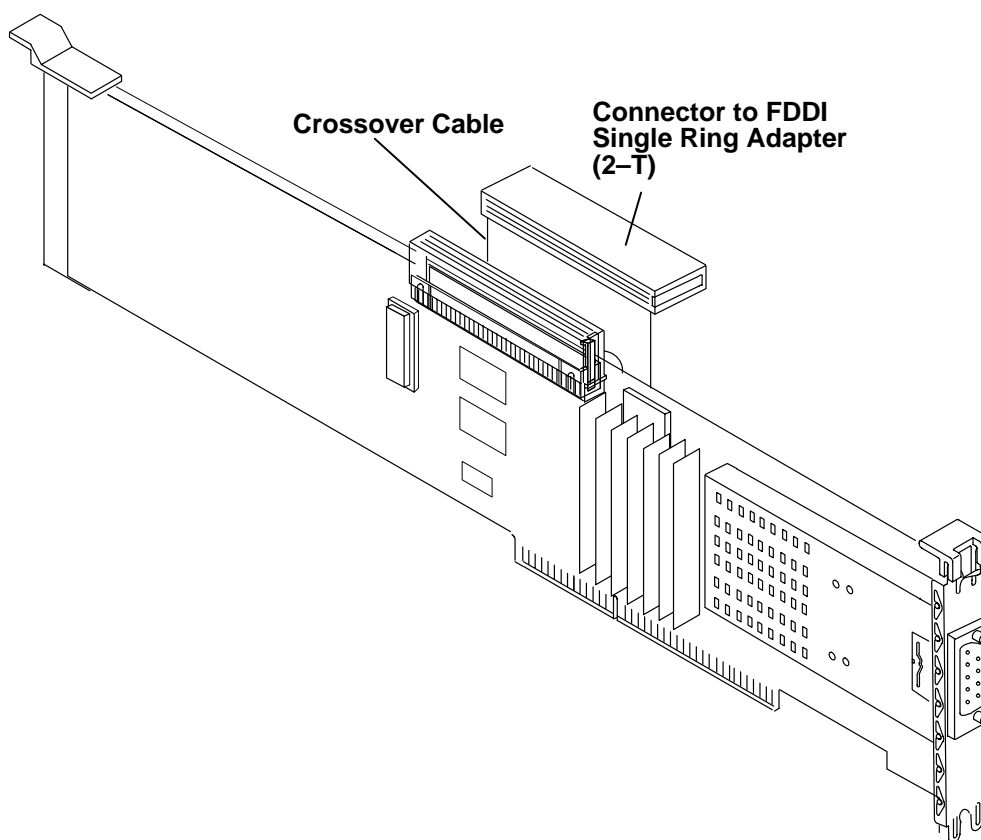

FDDI-STP Dual Ring Upgrade Kit Adapter Specifications

FRU number	43G0876
Maximum number	1 (7011) 2 (7012) 3 (7013/7016)
Bus architecture	Micro Channel
Connector	9-pin D-shell
Jumper Cables	FDDI-STP reversing cable adapter, 33G2762
Crossover Cable	93F1162
Wrap Plug	33G2759

Note: The cross over cable is too short if the two dual ring adapters are in some slots. If this is the case, move the adapters to different slots.

FDDI-STP Dual Ring Upgrade Kit Adapter 9-Position Connector

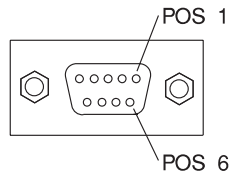

Position	Signal Name
1	Receive +
2	Not Used
3	Not Used
4	Not Used
5	Transmit +
6	Receive -
7	Not Used
8	Not Used
9	Transmit -

FC (2930, 2940, 2950) 8-Port Async Adapters (Types 3-1, 3-2, 3-3)

Each of these three adapters provide eight individually-addressable communication channels. When the multiport interface cable is attached to one of these adapter it provides eight EIA-232, EIA-422A, or MIL-STD 188 type communication ports.

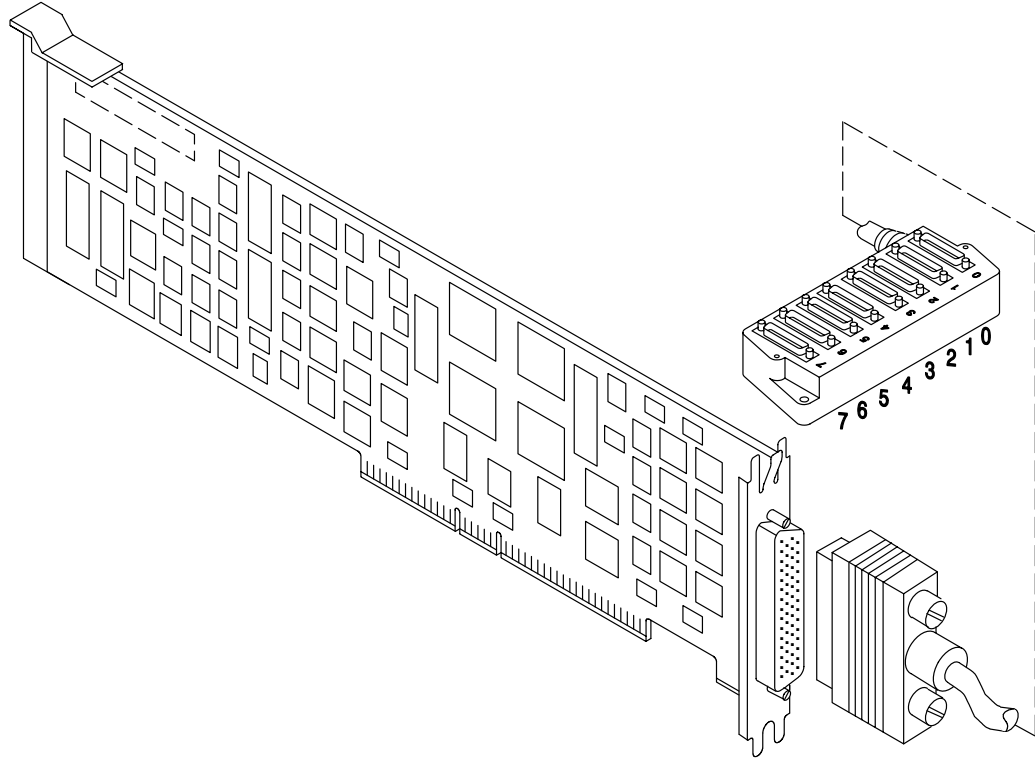

Specifications for the 8-Port Async Adapters

FRU Numbers	Type 3-1, EIA-232, part number 11H8607 Type 3-2, EIA-422A, part number 52G4757 Type 3-3, MIL-STD 188, part number 51G9246
I/O addresses	Assigned by the program within the 8100 - FD5F range
Interrupt levels	3, 5, 9, 10, 11, 12, 14, 15
Bit rate	50 - 38400 (set by the program)
Bits per character	5, 6, 7, 8 (set by the program)
Bus architecture	Micro Channel
Busmaster	No
Maximum number	8 (including 16-port adapters)
Connector	78-position, D-shell
Wrap plugs	78-position, part number 22F9694 EIA-232D 25-position, part number 6298964 EIA-422A 25-position cable, part number 30F9159
Cables	Multiport interface cable, part number 00F5524 8/16-port rack extension cable, part number 53F3048.

78-Position Connector on the 8-Port Async EIA-232 and MIL-STD 188 Adapter

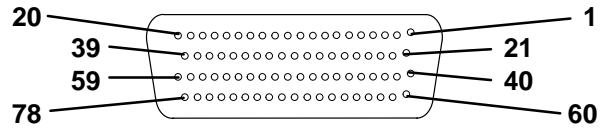

Position	Mnemonic	Port Number	Position	Mnemonic	Port Number
1	RTS	0	41	+5 V dc	
2	RxD	0	42	DSR	0
3	RI	0	43	Sig Gnd	3
4	TxD	1	44	Reserved	
5	Reserved		45	DCD	1
6	DSR	1	46	Reserved	
7	Sig Gnd	0	47	DTR	2
8	Sig Gnd	1	48	CTS	2
9	DCD	2	49	RI	4
10	RI	6	50	DTR	3
11	Sig Gnd	2	51	CTS	3
12	DCD	3	52	RI	5
13	RI	7	53	DSR	6
14	DSR	7	54	RxD	4
15	CTS	4	55	TxD	5
16	RTS	5	56	DCD	5
17	DTR	5	57	RxD	6
18	CTS	6	58	TxD	7
19	RTS	7	59	DCD	7
20	DTR	7	60	DTR	0
21	Reserved		61	CTS	0
22	DCD	0	62	Reserved	
23	Reserved		63	RTS	1
24	DTR	1	64	RxD	1
25	CTS	1	65	RI	1
26	Reserved		66	TxD	2
27	RTS	2	67	Sig Gnd	4,6
28	RxD	2	68	DSR	2
29	RI	2	69	TxD	3
30	RTS	3	70	Sig Gnd	5,7
31	RxD	3	71	DSR	3
32	RI	3	72	DSR	4
33	DSR	5	73	TxD	4
34	RTS	4	74	DCD	4
35	DTR	4	75	RxD	5
36	CTS	5	76	TxD	6
37	RTS	6	77	DCD	6
38	DTR	6	78	RxD	7
39	CTS	7			
40	TxD	0			

78-Position Connector on the 8-Port Async EIA-422A Adapter

Position	Mnemonic	Port Number	Position	Mnemonic	Port Number
1	+ TxD	0	41	Reserved	
2	- RxD	0	42	Reserved	
3	Reserved		43	Sig Gnd	0
4	- TxD	1	44	Reserved	
5	Reserved		45	Reserved	
6	Reserved		46	Reserved	
7	Sig Gnd	1	47	Reserved	
8	Sig Gnd	2	48	+ RxD	2
9	Reserved		49	Reserved	
10	Reserved		50	Reserved	
11	Sig Gnd	4	51	+ RxD	3
12	Reserved		52	Reserved	
13	Reserved		53	Reserved	
14	Reserved		54	- RxD	4
15	+ RxD	4	55	- TxD	5
16	+ TxD	5	56	Reserved	
17	Reserved		57	- RxD	6
18	+ RxD	6	58	- TxD	7
19	+ TxD	7	59	Sig Gnd	7
20	Reserved		60	Reserved	
21	Reserved		61	+ RxD	0
22	Reserved		62	Reserved	
23	Reserved		63	+ TxD	1
24	Reserved		64	- RxD	1
25	+ RxD	1	65	Reserved	
26	Reserved		66	- TxD	2
27	+ TxD	2	67	Sig Gnd	3
28	- RxD	2	68	Reserved	
29	Reserved		69	- TxD	3
30	+ TxD	3	70	Sig Gnd	5
31	- RxD	3	71	Reserved	
32	Reserved		72	Reserved	
33	Reserved		73	- TxD	4
34	+ TxD	4	74	Reserved	
35	Reserved		75	- RxD	5
36	+ RxD	5	76	- TxD	6
37	+ TxD	6	77	Sig Gnd	6
38	Reserved		78	- RxD	7
39	+ RxD	7			
40	- TxD	0			

FC (2955) 16-Port Async Adapter - EIA-232-D (Type 3-4)

This adapter provides 16 individually-addressable communication channels. Earlier versions of this adapter consisted of a base card and an electronics interface card. The base adapter and the electronics interface card combination are a single FRU. The latest version of this card is a single adapter. When the 16-port interface cable - EIA-232 is attached to this adapter, it provides 16, EIA-232-D communication ports.

Note: This adapter *does not* support all of the modem control signals. This adapter only provides the following signals: TxD, RxD, DCD, and DTR. The RTS signal line is pulled high at the interface cable.

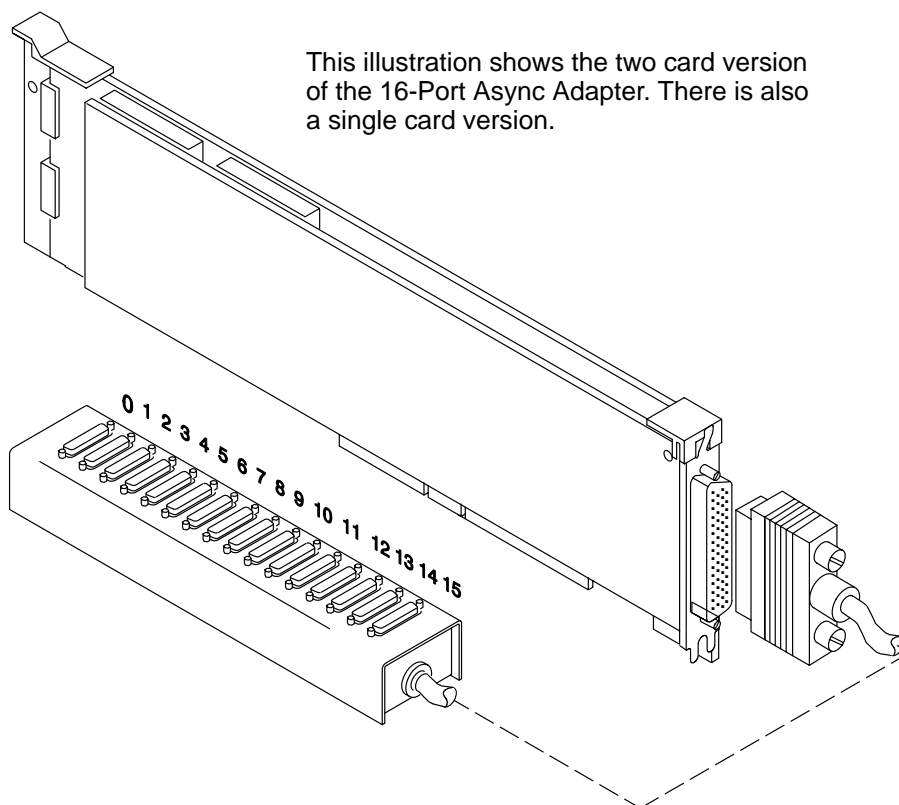

16-Port Async Adapter - EIA-232-D Specifications

FRU Numbers	Single card FRU 11H5762 Double card FRU 8184411
I/O addresses	Assigned by the program within the 8100 - FD5F range
Interrupt levels	3, 5, 9, 10, 11, 12, 14, 15
Bit rate	50 - 38400 (set by the program)
Bits per character	5, 6, 7, 8 (set by the program)
Bus architecture	Micro Channel
Busmaster	No
Maximum number	8 (including 8-port adapters)
Connector	78-position, D-shell
Wrap plugs	78-position, part number 53F3312 25-position, part number 6298964
Cables	16-port interface cable - EIA-232, part number 43G0463 8/16-port rack extension cable, part number 53F3048.

16-Port Async Adapter - EIA-232 78-Position Connector

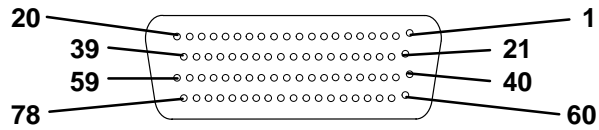

Position	Mnemonic	Port Number	Position	Mnemonic	Port Number
1	TxD	01	41	Reserved	
2	TxD	00	42	RxD	02
3	DCD	02	43	Reserved	
4	DCD	01	44	DCD	03
5	Reserved		45	DTR	05
6	RxD	03	46	Reserved	
7	TxD	05	47	TxD	07
8	DCD	04	48	TxD	06
9	DTR	06	49	TxD	08
10	DTR	08	50	Sig Gnd	04
11	DTR	07	51	DCD	09
12	RxD	10	52	DCD	11
13	RxD	09	53	DCD	10
14	RxD	11	54	DTR	12
15	TxD	13	55	Sig Gnd	
16	TxD	12	56	RxD	14
17	DCD	14	57	DTR	15
18	DCD	13	58	+ 12 V dc	
19	TxD	15	59	Sig Gnd	
20	Sig Gnd		60	DCD	00
21	RxD	01	61	DTR	02
22	RxD	00	62	DTR	01
23	TxD	02	63	RxD	04
24	TxD	04	64	TxD	03
25	DTR	03	65	DCD	05
26	Sig Gnd		66	DTR	04
27	RxD	05	67	RxD	07
28	Sig Gnd		68	RxD	06
29	DCD	06	69	RxD	08
30	DCD	08	70	TxD	10
31	DCD	07	71	TxD	09
32	DTR	09	72	TxD	11
33	DTR				
34	DTR				
35	RxD				
36	RxD				

FC (2957) 16-Port Adapter - EIA-422A (Type 3-5)

This adapter provides 16 individually-addressable communication channels. It consists of a printed circuit board and an electronics interface card. The board and electronics interface card combination are a single 1RU. When an EIA-422A connector is attached to this adapter, it provides 16 EIA-422A channels.

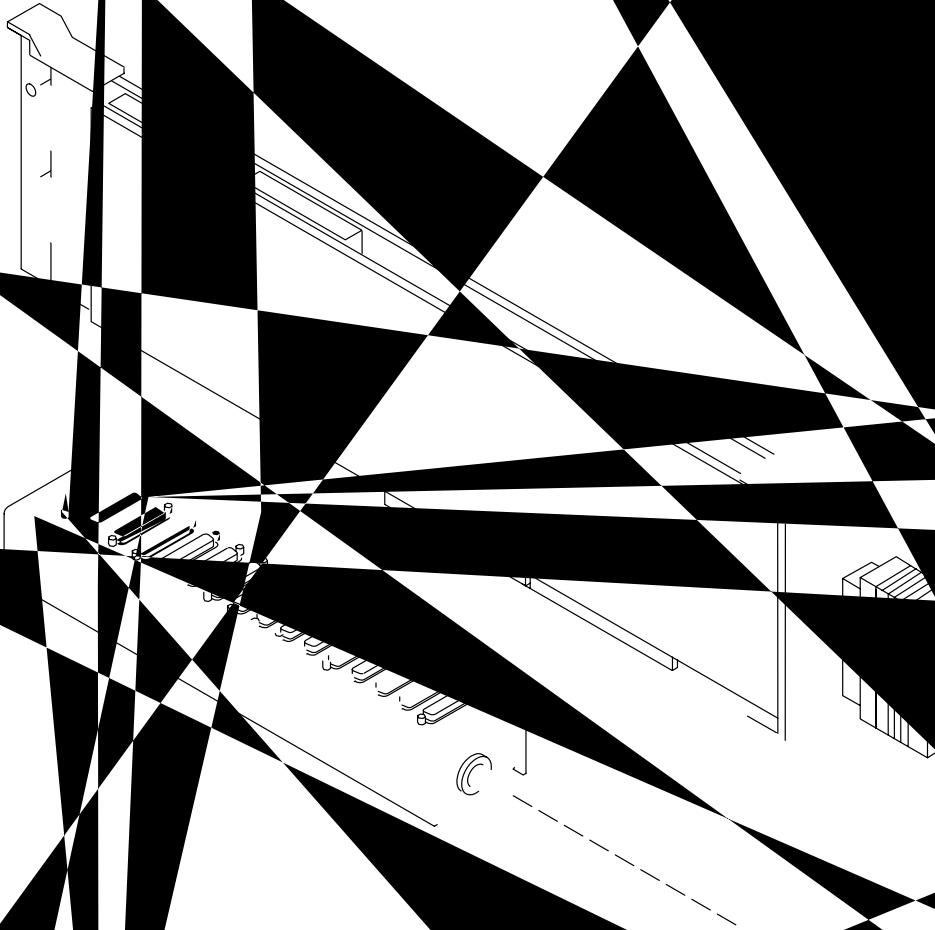

16-Port Async Adapter - EIA-422A 78-Position Connector

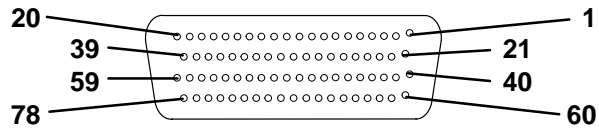

Position	Mnemonic	Port Number	Position	Mnemonic	Port Number
1	TxA	01	41	Reserved	
2	TxA	00	42	RxA	02
3	RxB	02	43	Reserved	
4	RxB	01	44	RxB	03
5	Reserved		45	TxB	05
6	RxA	03	46	Reserved	
7	TxA	05	47	TxA	07
8	RxB	04	48	TxA	06
9	TxB	06	49	TxA	08
10	TxB	08	50	Sig Gnd	04
11	TxB	07	51	RxB	09
12	RxA	10	52	RxB	11
13	RxA	09	53	RxB	10
14	RxA	11	54	TxB	12
15	TxA	13	55	Sig Gnd	
16	TxA	12	56	RxA	14
17	RxB	14	57	TxB	15
18	RxB	13	58	Reserved	
19	TxA	15	59	Sig Gnd	
20	Sig Gnd		60	RxB	00
21	RxA	01	61	TxB	02
22	RxA	00	62	TxB	01
23	TxA	02	63	RxA	04
24	TxA	04	64	TxA	03
25	TxB	03	65	RxB	05
26	Sig Gnd		66	TxB	04
27	RxA	05	67	RxA	07
28	Sig Gnd		68	RxA	06
29	RxB	06	69	RxA	08
30	RxB	08	70	TxA	10
31	RxB	07	71	TxA	09
32	TxB	09	72	TxA	11
33	TxB	11	73	Sig Gnd	
34	TxB	10	74	RxB	12
35	RxA	13	75	TxB	14
36	RxA	12	76	TxB	13
37	TxA	14	77	RxB	15
38	Sig Gnd		78	Reserved	
39	RxA	15			
40	TxB	00			

FC (6400) 64-Port Async Controller (Type 3-6)

This adapter provides the control function and connectors to attach four 16-port async concentrators. When all four concentrators are attached, this combination provides 64, EIA-232 communication ports.

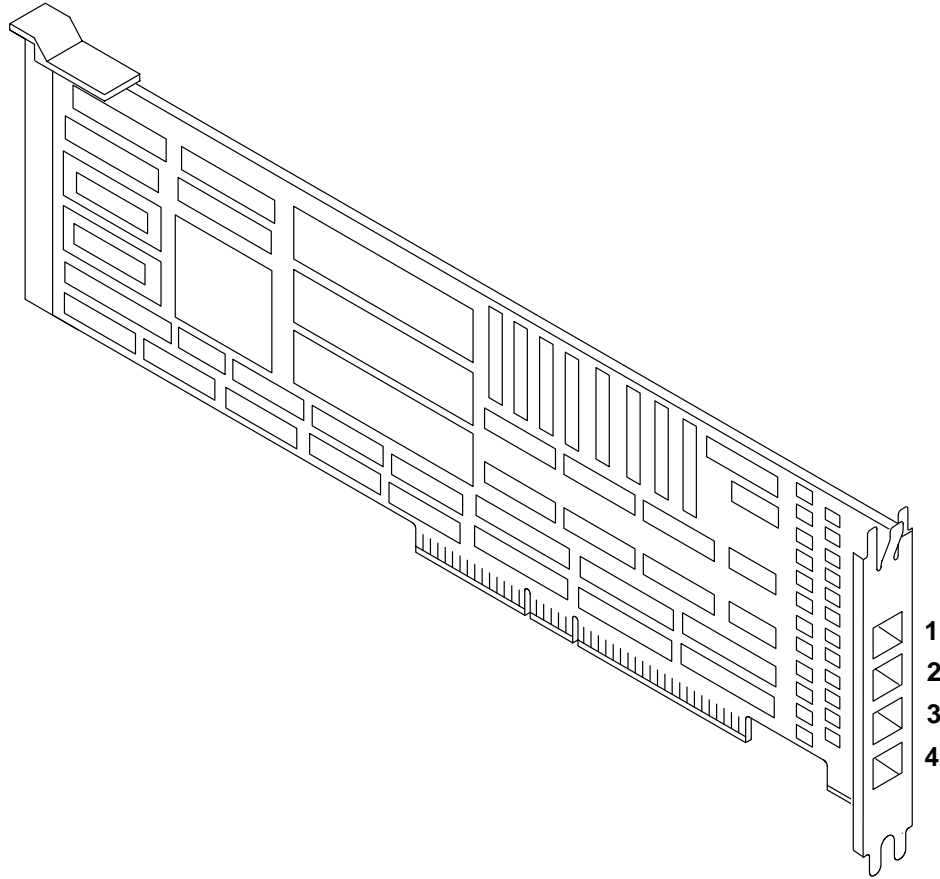

64-Port Async Controller Specifications

FRU Number	32G1412
Memory addresses	256K Bytes of continuous non-shared memory space (four 64K byte blocks)
Interrupt levels	3, 4, 5, 7, 10, 11, 12, 15
Bit rate	75 to 38400 bps (set by the program)
Bits per character	5, 6, 7, 8 (set by the program)
Parity	Odd, even, or none
Stop bits	1, 1.5, 2
Bus architecture	Micro Channel
Busmaster	No
Maximum number	8
Connectors	Four, RJ-45 connectors
Wrap plug	Part number 53F3623
Cable	7.6 m (25 feet) controller cable, part number 53F3368.

8-Position RJ-45 Controller Connector

The signals and connector position numbers are the same for each of the controller connectors.

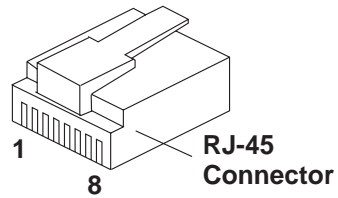

Position	Signal Name
1	Transmit data - A
2	Transmit data - B
3	No connection
4	Transmit clock - B
5	Transmit clock - A
6	Shield
7	Receive data - B
8	Receive data - A

FC (6401) 16-Port Async Concentrator

The 16-port async concentrator attaches to the 64-port async controller. Four of these concentrators can be attached to a single 64-port async controller. This combination provides a total of 64 communications ports. When the RJ-45 to DB-25 converter cable is attached to a port, the port is an EIA-232 compatible connection refer to ("Cable N" on page 5-22 for cabling information).

The 16-port async concentrator can be located up to 762 meters (2500 feet) from the controller.

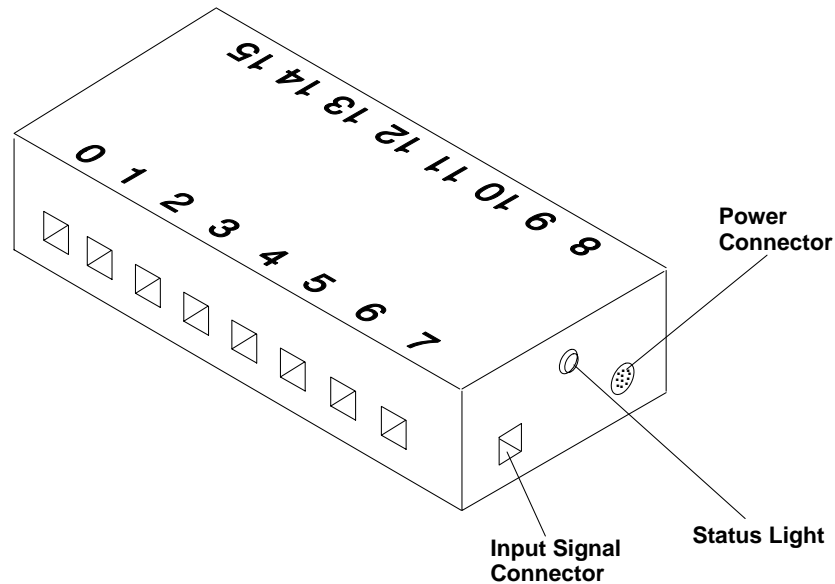

16-Port Async Concentrator Specifications

FRU Number	43G0893
Connectors	Seventeen, 8-position RJ-45 connectors
Wrap plugs	Input cable, part number 53F3205 Output connector, part number 53F3624
Cables	7.6 m (25 feet) controller cable, part number 53F3368 RJ-45 to DB-25 converter cable, part number 53F3367 (Available only in four-cable kit, 59F3432).

16-Port Async Concentrator 8-Position RJ-45 Input and Output Connectors

The connector positions and signals for each RJ-45 connector is the same. See 5-24 for information on the Concentrator-to-Device cables.

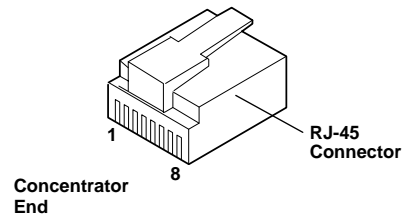

Positions	Mnemonic (Signal Name)
1	GND (concentrator chassis ground)
2	RTS (request to send)
3	RxD (receive data)
4	CD (carrier detect)
5	Sig Gnd (signal ground)
6	TxD (transmit data)
7	DTR (data terminal ready)
8	CTS (clear to send)

16-Port Async Concentrator Power Transformers

There are two types of power transformers for the 16-port async concentrator. The outlet mounted type only comes in the 115 - 127 V ac range and the transformers with a removable power cord. The tables on pages 1-84 and 1-85 list available transformers and removable power cables.

Outlet-mounted
Other Removable Power Cable

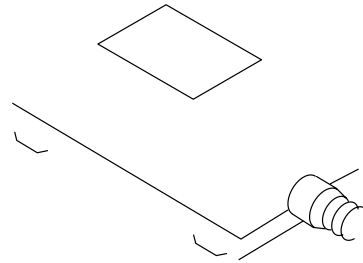
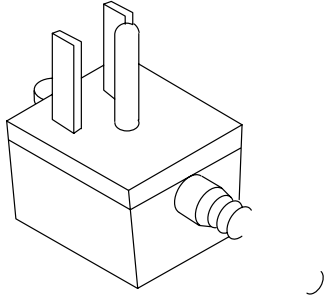

16-Port Async Concentrator Removable Power Cables

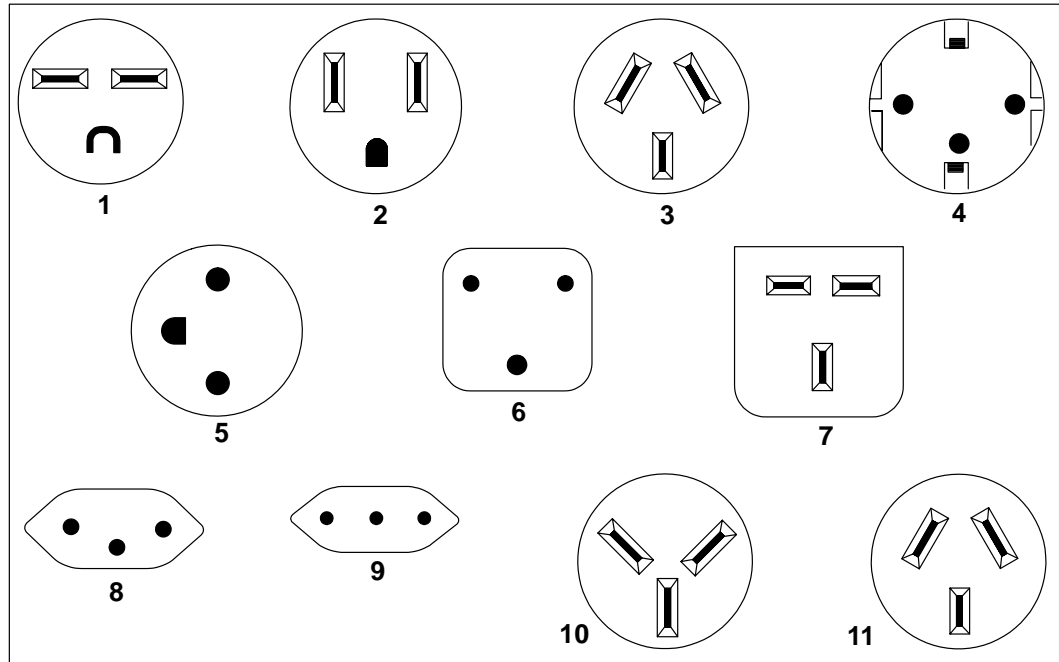

Index	Part Number	Country
1	1838574	Bahamas, Barbados, Bolivia, Canada, Costa Rica, Dominican Republic, El Salvador, Ecuador, Guatemala, Honduras, Jamaica, Japan, Netherlands Antilles, Panama, Peru, Trinidad, Philippines, Taiwan, Thailand, Venezuela
2	6952300	Bolivia, Dominican Republic, Ecuador, Guyana, Honduras, Jamaica, Japan, Korea, Netherlands Antilles, Philippines, Surinam, Taiwan, U.S.A. (except Chicago), Venezuela
	62X1045	Chicago, U.S.A.
3	6952311	Argentina, Australia, New Zealand
4	6952320	Austria, Belgium, Botswana, Egypt, Finland, France, Korea, West Germany
5	6952329	Denmark
6	6952347	Bangladesh, Burma, India, Pakistan, South Africa, Sri Lanka
7	6952356	Bahrain, Bermuda, Brunei, China, Ghana, Hong Kong, Iraq, Ireland, Jordan, Kenya, Kuwait, Malawi, Macao, Malaysia, Nigeria, Oman, Qatar, Singapore, Tanzania, Uganda, United Arab Emirates, U.K., Zambia
8	6952365	Switzerland
9	6952374	Chile, Ethiopia, Italy
10	6952383	Israel
11	6952291	Colombia, Uruguay

FC (8128) 128-Port Async Controller (Type 3-7)

This adapter provides the control function and connectors to attach eight 16-port remote async nodes. When all eight nodes are attached, this combination provides 128, EIA-232-D communication ports. The remote async nodes are described in the following topic. More information pertaining to the 128-Port Async Controller can be found in the following publication *AIX Versions 3.2 and 4 Asynchronous Communications Guide* order number SC23-2488.

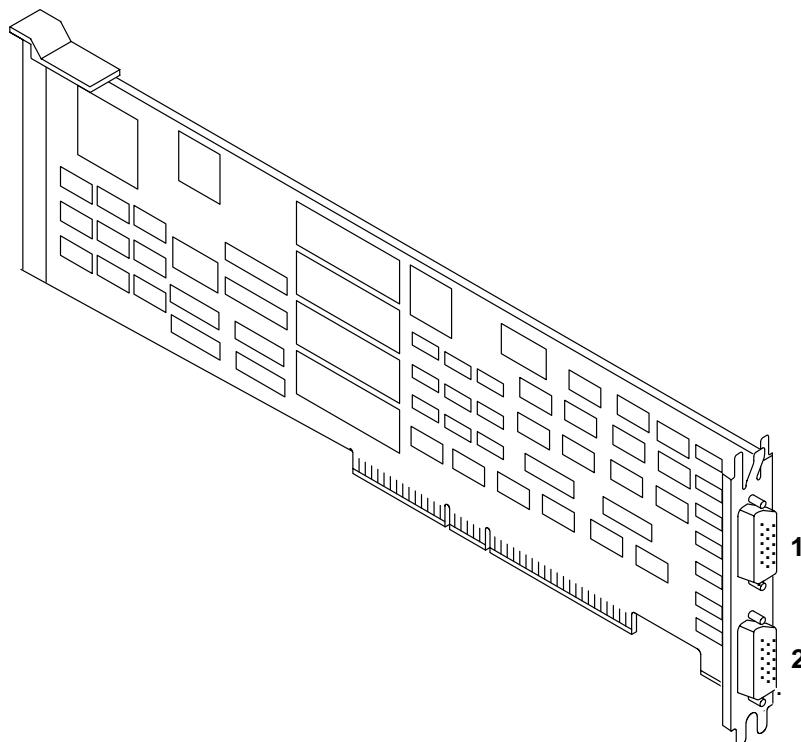

128-Port Async Controller Specifications

FRU Number	52G4894
Memory addresses	512K Bytes of continuous non-shared memory space (sixteen 32K Byte blocks)
Interrupt levels	3, 4, 5, 7, 10, 11, 12, 15
Bit rate	75 to 57,600 bps (set by the program)
Bits per character	5, 6, 7, 8 (set by the program)
Parity	Odd, even, or none
Stop bits	1, 2
Bus architecture	Micro Channel
Busmaster	No
Maximum number	7
Connectors	Two, HD-15 connectors
Terminator plugs	HD-15, part number 43G0938
Cables	0.2 m (9 inches) controller cable, part number 43G0936 4.6 m (15 feet) controller cable, part number 43G0937

128-Port Async Controller 15-Position HD-15 Connector

The signals and connector position numbers are the same for each of the controller connectors.

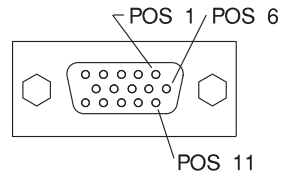

Controller Connector (female)

Position	Mnemonic
1	RxD-
2	RxD+
3	Reserved
4	RxC-
5	RxC+
6	TxD-
7	TxD+
8	Reserved
9	TxC-
10	TxC+
11	Reserved
12	GND (chassis)
13	Reserved
14	Reserved
15	Reserved

Autoconfiguration

The 128-port async subsystem autoconfigures with the following settings when initially installed. Hardware reconfiguration must be done through SMIT.

- 8-wire cabling
- 1,200,000 bps controller line speed
- no sync modems

Remote Async Nodes

The 16-port original or enhanced remote async node (RAN) attaches to a 128-port async controller. Eight remote async nodes can be attached to a single 128-port async controller. This combination provides a total of 128 communications ports. The original async nodes and enhanced RANs can be used in any combination. For RAN to device data rates when mixing original RANs and Enhanced RANs. See “Cabling the adapter and the four different Remote Async Nodes” on page 5-28. When the RJ-45 to DB-25 converter cable is attached to a port, the port is an RS-422 or EIA-232 compatible connection. More information pertaining to the remote async nodes can be found in the publication, *AIX Versions 3.2 and 4 Asynchronous Communications Guide* order number SC23-2488.

The last 16-port remote async node on a controller line can be located up to 300 meters (1000 feet) from the controller when configured at the maximum controller line data rate. Distances up to 1200 meters (3930 feet) are supported at lower controller line data rates. See controller line data rates table in “Line Length, 8-wire” on page 5-30. Remote async nodes may also be remotely located via either RS-422 or EIA-232 synchronous modems.

FC (8130, 8137, and 8138) Remote Async Nodes 16-Port Box Style

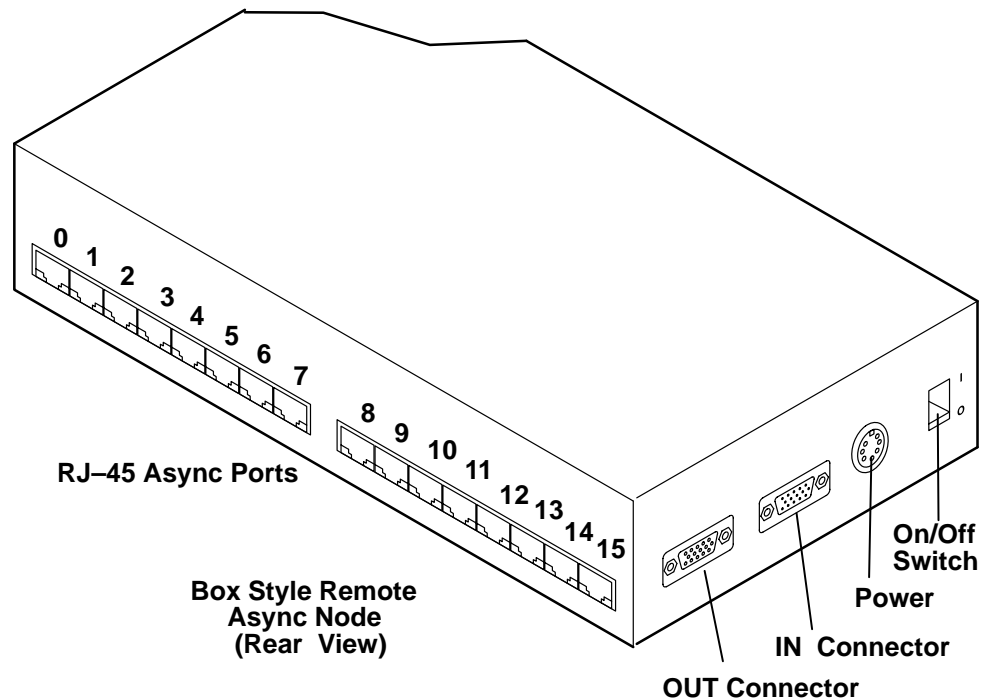

Feature code	RAN Description
8130	EIA-232 original
8137	EIA-232 enhanced
8138	RS-422 enhanced

FC (8136) Remote Async Node 16-Port EIA-232 Rack Style

The 16 Ports of EIA-232 on the rack style RAN have the same characteristics as those of the box style RAN. The operator panel on the rack style is the same and is used the same as the one on the box style. Also, the cabling of the box and rack styles is the same. The main difference between the box style RAN and the rack style is the form factor and the power supply. The physical shape is seen to be different. The box style is powered by a transformer that supplies low voltage to the RAN while the rack style is powered directly from the wall AC outlet at 100 or 200 volts AC.

The rack style of RAN comes with brackets (not shown) to enable mounting the unit in a rack. The rack style RAN is one EIA unit high. The front of the rack has the 16 EIA-232 RJ-45 connectors and the operator panel.

Front of Rack Style Remote Async Node

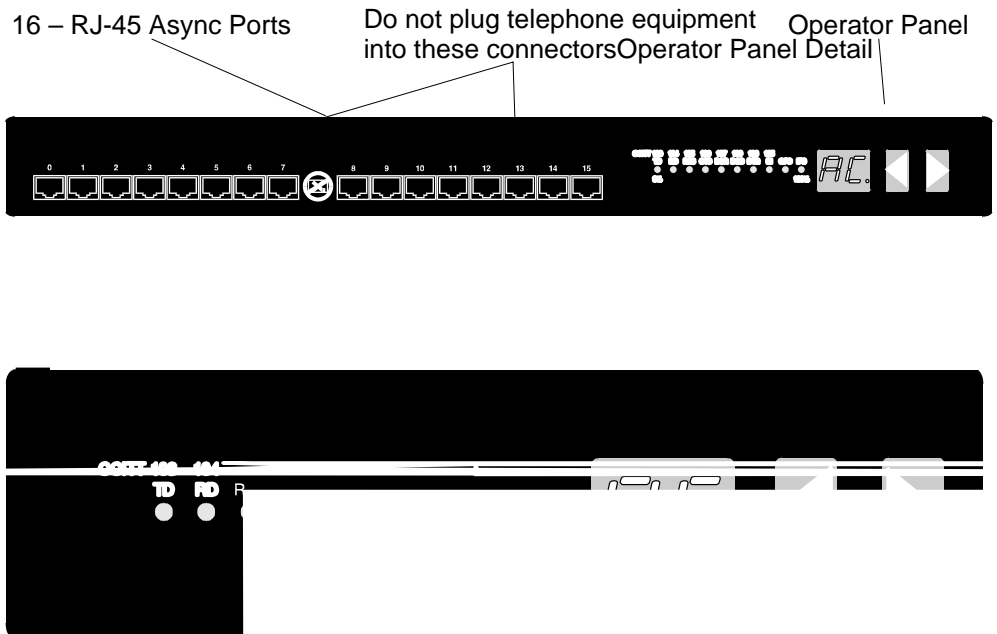

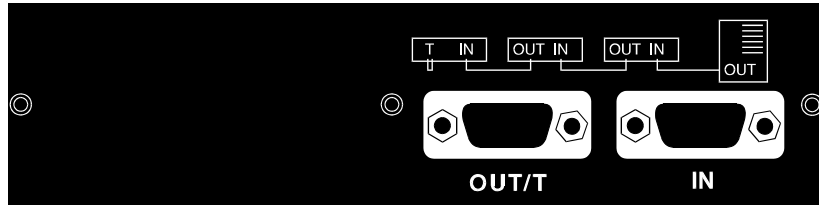

Connectors for Cabling Adapter and RANs Together

16-Port Remote Async Node Specifications

Item	Definition
FRU number	
Box Style	FC (8130) 88G3842 FC (8137) 93H6549 FC (8138) 93H6563
FRU number	
Rack Style	FC (8136) 40H2589
Connectors	Sixteen, 10 position RJ-45 connectors One 15-position male HD-15 connector One 15-position female HD-15 connector
Wrap plug	RJ-45, part number 43G0928
Terminator	HD-15, part number 43G0926
Cables	See "FC 8128 (128-Port Async Controller)" on page 3-8

Remote Async Node Front Panel

The front panel is used to monitor system activity and to program the Remote Async Node with a unique node number. This node number is used by the 128-Port Async Controller to identify each Remote Async Node on a controller line.

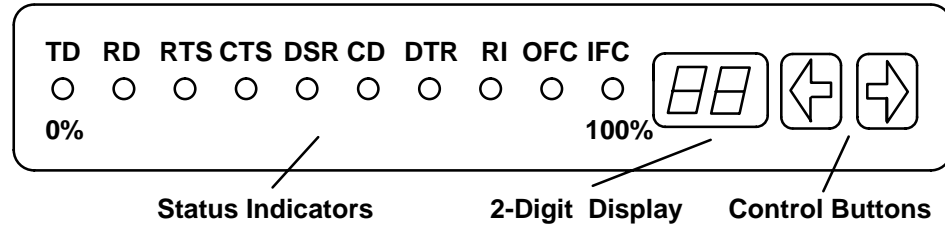

During boot, the following actions occur:

- Status indicators and the two-digit display are cycled, indicating that the remote async node POST is in progress.
- P0 in the two-digit display indicates the final POST stages.
- P1 in the two-digit display indicates POST is complete.
- P4 in the two-digit display indicates that microcode is being received.

Following a successful boot, system activity is displayed and the status indicators cycle at a rate proportional to async traffic. The following display modes can be viewed in the two-digit display by using the left and right arrow buttons on the front panel:

Two-Digit Display/Mode	Description
AC	Activity; status indicators cycle proportionally to async traffic.
0-15	Port monitor; two-digit displays shows current async port being monitored; status indicators operational (OFC shows output flow control active; IFC shows input flow control active).
PC	Packet count; status indicators show binary representation of total packets transmitted or received.
EC	Error count; status indicators show binary representation of error counts on the controller line.
PU	Processor utilization; status indicators act as bar graph showing percentage of time that the remote async node microprocessor is being used.
LU	Line utilization; status indicators act as bar graph showing percentage of time that the controller line is being used.
Ed	POST failed, Fatal error
1n, 2n,8n	Node number; two-digit display shows the node number currently programmed into the remote async node.

Programming the Remote Async Node

Each remote async node must be programmed with a "Node Number" prior to system IPL. The remote async node front panel is used to perform the following programming steps.

Note: Only four remote async nodes can be attached to each connector on the controller; only node numbers 1 through 4 are valid.

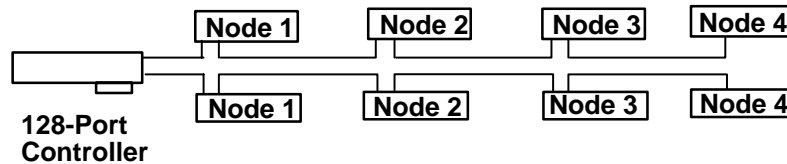

1. Perform a system shutdown, and then power-off the system.
2. Power-on the remote async node; the Power-On Self Test (POST) begins. During the POST, the characters PO appear in the two-digit display.
3. When the POST is complete, P1 appears in the two-digit display and the remote async node is ready for the following programming steps:

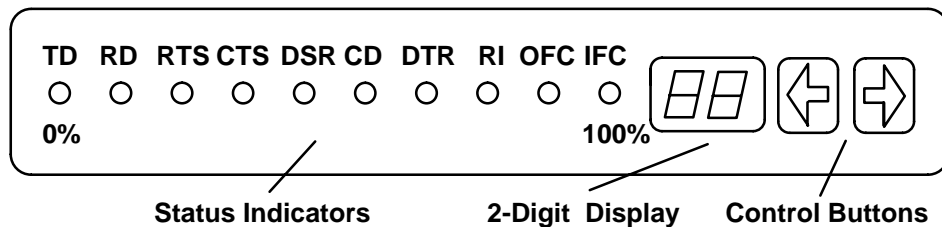

- a. Press the left arrow button to enter the programming mode. The current node number appears in the two-digit display.
 - b. Press the right arrow button repeatedly until the desired node number is displayed. Continued pressing of this button cycles the two-digit display through 8 and back to 1.
- Note:** Node numbers should be assigned in ascending order on each controller line, beginning with the remote async node closest to the controller. That is, the remote async node closest to each controller connector would be assigned number 1. Numbers greater than 4 are not configured.
- c. Press the left arrow to select the node number entered in the previous step. Pn appears momentarily in the two-digit display, meaning that the node has been successfully programmed. The display then returns to P1 and awaits microcode download from the controller.
4. The system IPL may be performed now. The characters AC in the two-digit display indicate that IPL is complete and remote access node programming successfully completed without error.
 5. If En appears in the two-digit display, the remote async node has been improperly programmed in one of the following ways:
 - The remote async nodes have not been programmed in ascending order. That is, the remote async node displaying the En has been programmed to a lower number than the preceding node.

- Two or more remote async nodes have been programmed assigned the same number. The remote async node displaying the En has been programmed to the same number as another node on the same controller connector.

16-Port Remote Async Node 10-Position RJ-45 Input and Output Connectors

For EIA-232 Remote Async Nodes

The connector positions and signals for each RJ-45 connector on the Remote Async Node are the same (see table below). Chapter 5 "Cable Assembly and Pin-outs" contains the information to build converter cables (Cable NK) and cables that can go directly from the Remote Async Node to EIA-232 devices (cables NL and NM). See "Remote Async Node-to-Device Cables" on page 5-37.

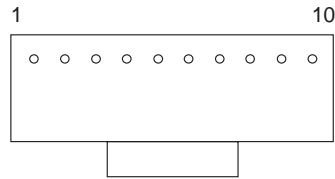

This is the rear view.

Positions	Mnemonic (Signal Name)
1	RI (ring indicator)
2	DSR (data set ready)
3	RTS (request to send)
4	GND (chassis ground)
5	TxD (transmit data)
6	RxD (receive data)
7	SG (signal ground)
8	CTS (clear to send)
9	DTR (data terminal ready)
10	DCD (data carrier detect)

For RS-422 Remote Async Nodes

The connector positions and signals for each RJ-45 connector on the Remote Async Node are the same (see table below). Chapter 5 "Cable Assembly and Pin-outs" contains the information to build converter cables and cables that can go directly from the Remote Async Node to RS-422 devices (cable NP). See "Cable NP" on page 5-43. Six wires are required to connect the RAN to a RS-422 device.

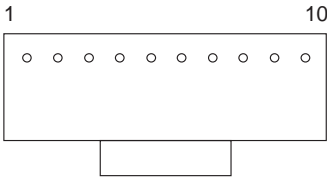

This is the rear view.

Positions	Mnemonic (Signal Name)
1	Reserved
2	Reserved
3	TxD + (+ transmit data)
4	GND (chassis ground)
5	TxD - (- transmit data)
6	RxD - (- receive data)
7	SG (signal ground)
8	RxD + (+ receive data)
9	Reserved
10	Reserved

16-Port Remote Async Node Power Supplies

Box Style Power

The box style remote async nodes use a transformer as shown below.

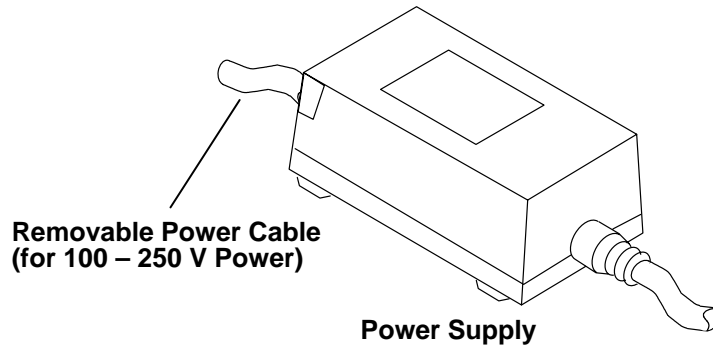

The following table lists the power supply and the table on the next page lists the removable power cables for the 16-port remote async node.

Feature Code	Voltage Range and Frequency	Removable Power Cable	Power Supply Part Number
8130	100 - 250 V ac at 50 or 60Hz	Yes	40H3611/93H7091
8137	100 - 250 V ac at 50 or 60Hz	Yes	93H7091
8138	100 - 250 V ac at 50 or 60Hz	Yes	93H7091

Rack Style Power

The rack style remote async nodes use a removable power cable and are powered directly by 100 - 250 V ac at 50 or 60Hz.

16-Port Remote Async Node Removable Power Cables

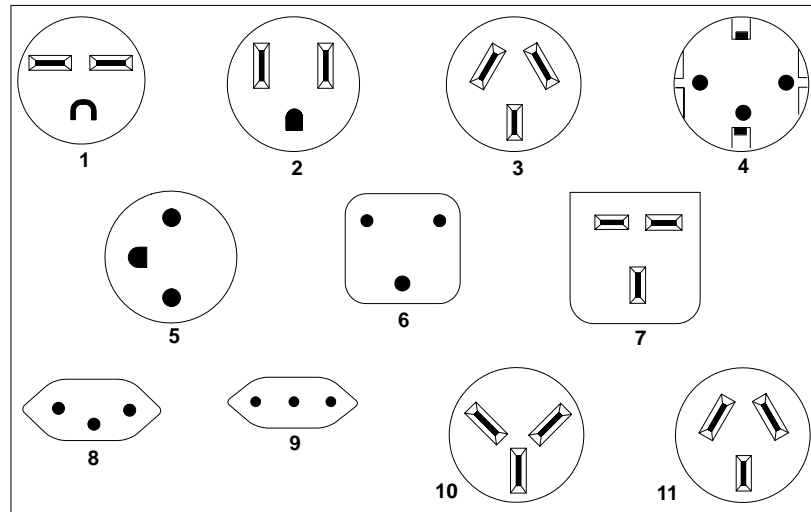

Power Plug Table

Index	Part Number	Country
1	1838574	Bahamas, Barbados, Bolivia, Canada, Costa Rica, Dominican Republic, El Salvador, Ecuador, Guatemala, Honduras, Jamaica, Japan, Netherlands Antilles, Panama, Peru, Trinidad, Philippines, Taiwan, Thailand, Venezuela
2	6952300	Bolivia, Dominican Republic, Ecuador, Guyana, Honduras, Jamaica, Japan, Korea, Netherlands Antilles, Philippines, Surinam, Taiwan, U.S.A. (except Chicago), Venezuela, Canada
	62X1045	Chicago, U.S.A.
3	6952311	Argentina, Australia, New Zealand
4	6952320	Austria, Belgium, Botswana, Egypt, Finland, France, Korea, West Germany
5	6952329	Denmark
6	6952347	Bangladesh, Burma, India, Pakistan, South Africa, Sri Lanka
7	6952356	Bahrain, Bermuda, Brunei, China, Ghana, Hong Kong, Iraq, Ireland, Jordan, Kenya, Kuwait, Malawi, Macao, Malaysia, Nigeria, Oman, Qatar, Singapore, Tanzania, Uganda, United Arab Emirates, U.K., Zambia
8	6952365	Switzerland
9	6952374	Chile, Ethiopia, Italy
10	6952383	Israel
11	6952291	Colombia, Uruguay

SCSI Single-Ended High-Performance Internal/External I/O Controller Connectors

Two SCSI interface connectors are provided: a 50-position top edge connector and an external 60-position connector. The 50-position top edge connector attaches the SCSI devices inside the system unit. The external 60-position connector attaches SCSI devices outside the system unit.

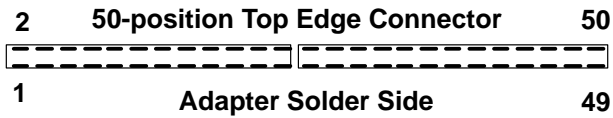

External 60-Position Connector

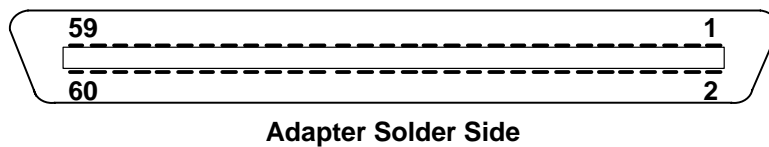

Signal Name or Mnemonic	Signal on Position	Ground on Position
-Data Bus (0)	2	1
-Data Bus (1)	4	3
-Data Bus (2)	6	5
-Data Bus (3)	8	7
-Data Bus (4)	10	9
-Data Bus (5)	12	11
-Data Bus (6)	14	13
-Data Bus (7)	16	15
-Data Bus (P)	18	17
Ground		19-24
No connection	25	
TERMPWR	26	27-31
-ATN	32	33-34
-BSY	36	35
-ACK	38	37
-RST	40	39
-MSG	42	41
-SEL	44	43
-C/D	46	45
-REQ	48	47
-I/O	50	49
Reserved (Do not connect)	51-60	

FC (2420) SCSI-2 Differential High-Performance External I/O Controller (Type 4-2)

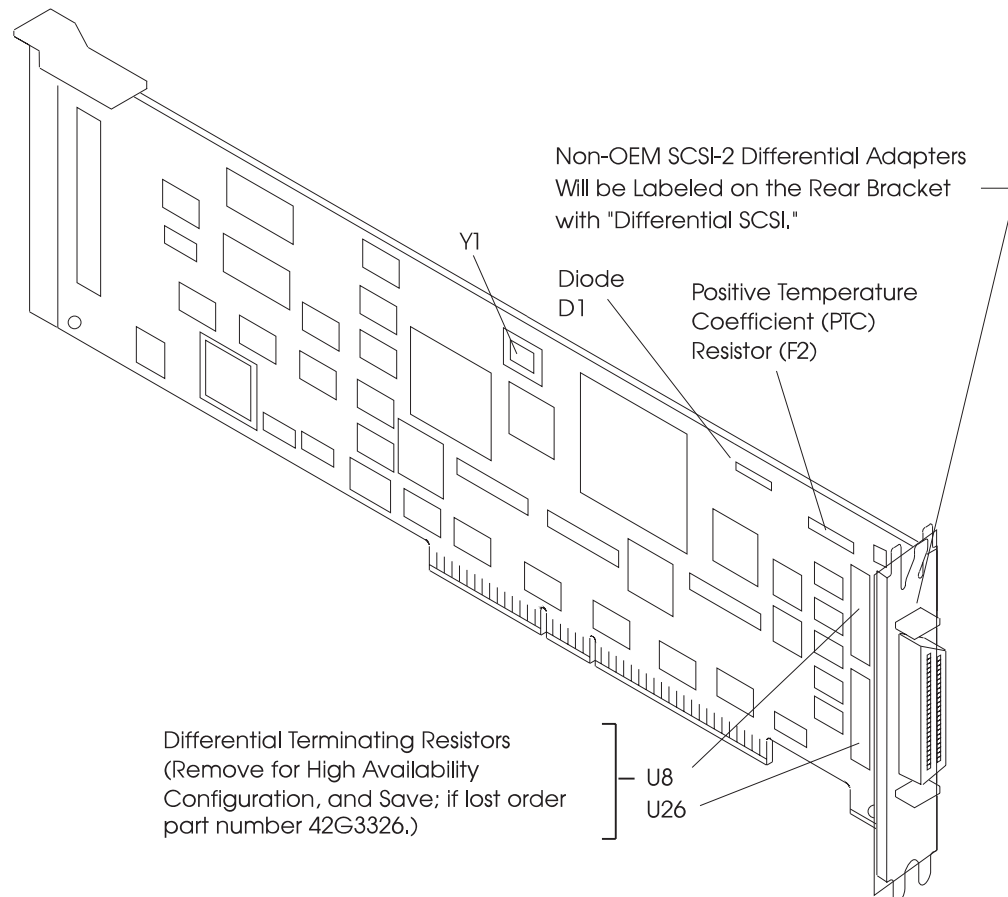

SCSI-2 Differential High-Performance External I/O Controller Specifications

FRU number	43G0176 or 11H2447
Interrupt levels	3, 4, 5, 7, 10, 11, 12, 14
Bus architecture	Micro Channel
Maximum number	2 controllers per Micro Channel bus (7012/360/36T/370/37T) 4 controllers per Micro Channel bus (7013, 7015/950) 4 controllers per Micro Channel bus (two busses on 7015/970/97B/980/98B/990/R24)
Microcode filename	8d77.xx.xx
Connector	External 50-position, high density SCSI device connector
Cables/Terminators	Refer "System Differential Internal Cable Lengths" on page 4-29 of this manual.
SCSI bus overcurrent Protection device	Positive Temperature Coefficient (PTC) resistor. Refer to "Overload Protection and Terminator Power (Term Power)" on page 4-7. For PTC test procedures, see "SCSI-2 Differential Controller PTC Failure Isolation" in the <i>RS/6000 Diagnostic Information for Micro Channel Bus Systems</i> . Order number SA38-0532.

SCSI-2 Differential High-Performance External I/O Controller Connector

The external 50-position high density connector attaches SCSI devices outside the system unit. This connector is equivalent to the SCSI-2 standard 50-position shielded high-density connector (the "A" connector).

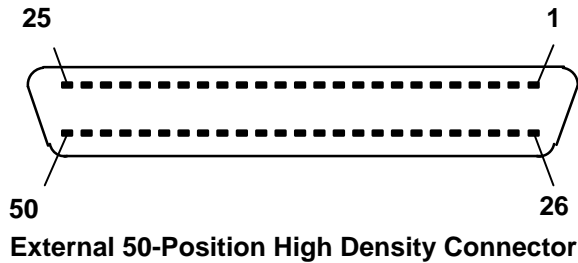

Pin	Signal Name	Pin	Signal Name
1	Ground	26	Ground
2	+DB(0)	27	-DB(0)
3	+DB(1)	28	-DB(1)
4	+DB(2)	29	-DB(2)
5	+DB(3)	30	-DB(3)
6	+DB(4)	31	-DB(4)
7	+DB(5)	32	-DB(5)
8	+DB(6)	33	-DB(6)
9	+DB(7)	34	-DB(7)
10	+DB(P)	35	-DB(P)
11	DIFFSENS	36	Ground
12	Reserved*	37	Reserved*
13	TERMPWR	38	TERMPWR
14	Reserved*	39	Reserved*
15	+ATN	40	-ATN
16	Ground	41	Ground
17	+BSY	42	-BSY
18	+ACK	43	-ACK
19	+RST	44	-RST
20	+MSG	45	-MSG
21	+SEL	46	-SEL
22	+C/D	47	-C/D
23	+REQ	48	-REQ
24	+I/O	49	-I/O
25	Ground	50	Ground

*Reserved lines are grounded in bus terminator assemblies and are open on SCSI devices. Refer to Section 4.4.4 in ANSI X3T9.2/86-109 rev. 10h for more information.

FC (6210) High Performance Disk Drive Subsystem Adapter (Type 4-3)

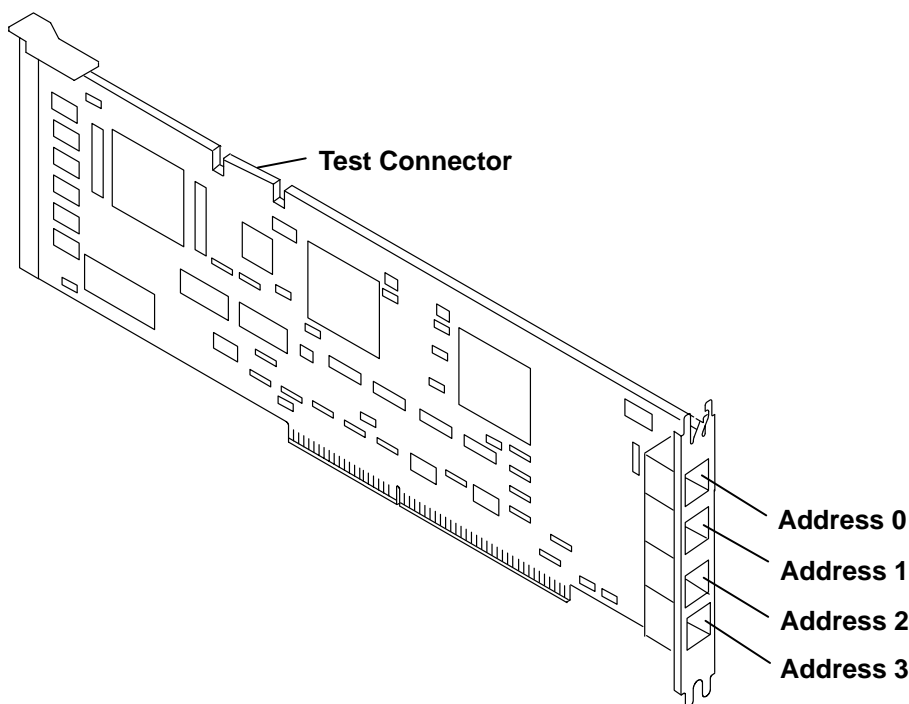

High Performance Disk Drive Subsystem Adapter Specifications

FRU number	52G1071
Bus architecture	Micro Channel
Maximum number	1 (7012, 7013) 4 (7015/930/950) 7 (7015/970/980)
Microcode filename	8f78.xx.xx
Data transfer rate	40 MB/second
Connector	6-position, serial link
Cables	Serial link, 9333 attachment, 10 m (33 ft) 07G4859 Serial link, 9333 attachment, 3 m (10 ft) 07G4860

Note: This adapter should be located in Slots 1 through 4. When this adapter is reported to have failed, check its slot position before replacing; if it is mounted in Slots 5 through 8, relocate the adapter to Slots 1 through 4 and try again.

High Performance Disk Drive Subsystem Adapter Connector

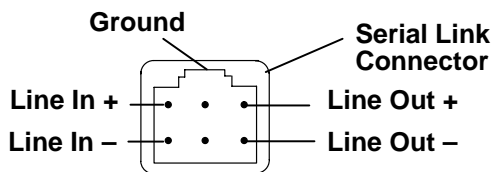

FC (2410, 2831) SCSI-2 Single-Ended High Performance Internal/External I/O Controller (Type 4-4)

Note: Small Computer Systems Interface is also referred to as SCSI in this publication.

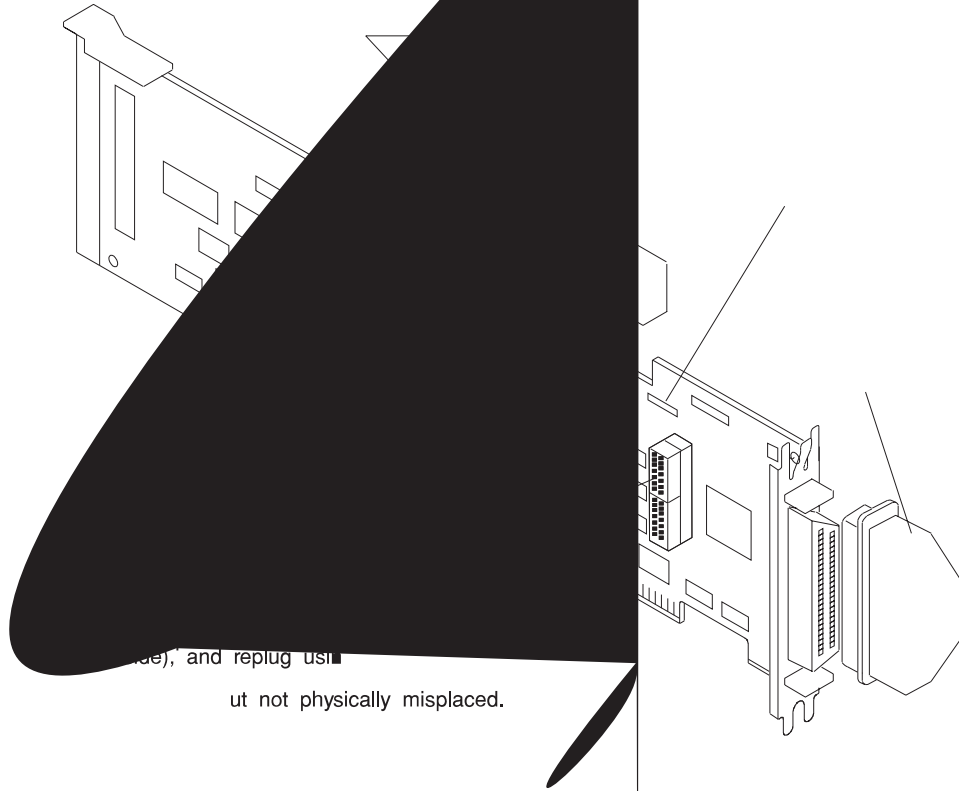

SCSI-2 Single-Ended High-Performance Internal/External I/O Controller Connectors

Two SCSI interface connectors are provided: a 50-position top edge connector and an external 50-position high density connector. The 50-position top edge connector attaches the SCSI devices inside the system unit. The external 50-position high density connector attaches SCSI devices outside the system unit. This connector is equivalent to the SCSI-2 standard 50-position shielded high-density connector (the "A" connector).

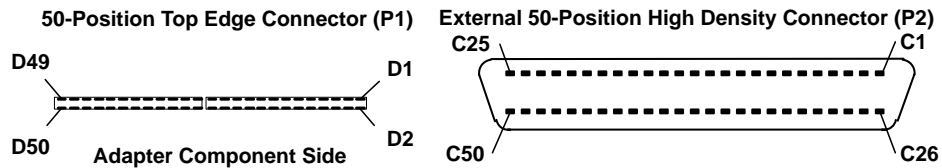

Signal Name	P2 Pin	P1 Pin	P1 Pin	P2 Pin	Signal Name
Ground	C1	D1	D2	C26	-DB(0)
Ground	C2	D3	D4	C27	-DB(1)
Ground	C3	D5	D6	C28	-DB(2)
Ground	C4	D7	D8	C29	-DB(3)
Ground	C5	D9	D10	C30	-DB(4)
Ground	C6	D11	D12	C31	-DB(5)
Ground	C7	D13	D14	C32	-DB(6)
Ground	C8	D15	D16	C33	-DB(7)
Ground	C9	D17	D18	C34	-DB(P)
Ground	C10	D19	D20	C35	Ground
Ground	C11	D21	D22	C36	Ground
Reserved*	C12	D23	D24	C37	Reserved*
Open	C13	D25	D26	C38	TERMPWR
Reserved*	C14	D27	D28	C39	Reserved*
Ground	C15	D29	D30	C40	Ground
Ground	C16	D31	D32	C41	-ATN
Ground	C17	D33	D34	C42	Ground
Ground	C18	D35	D36	C43	-BSY
Ground	C19	D37	D38	C44	-ACK
Ground	C20	D39	D40	C45	-RST
Ground	C21	D41	D42	C46	-MSG
Ground	C22	D43	D44	C47	-SEL
Ground	C23	D45	D46	C48	-C/D
Ground	C24	D47	D48	C49	-REQ
Ground	C25	D49	D50	C50	-I/O

*Reserved lines are grounded in bus terminator assemblies and are open on SCSI devices. Refer to Section 4.4.4 in ANSI X3T9.2/86-109 rev. 10h for more information.

FC (6211) High-Performance Disk Drive Subsystem Adapter (80M Byte/S) (Type 4-5)

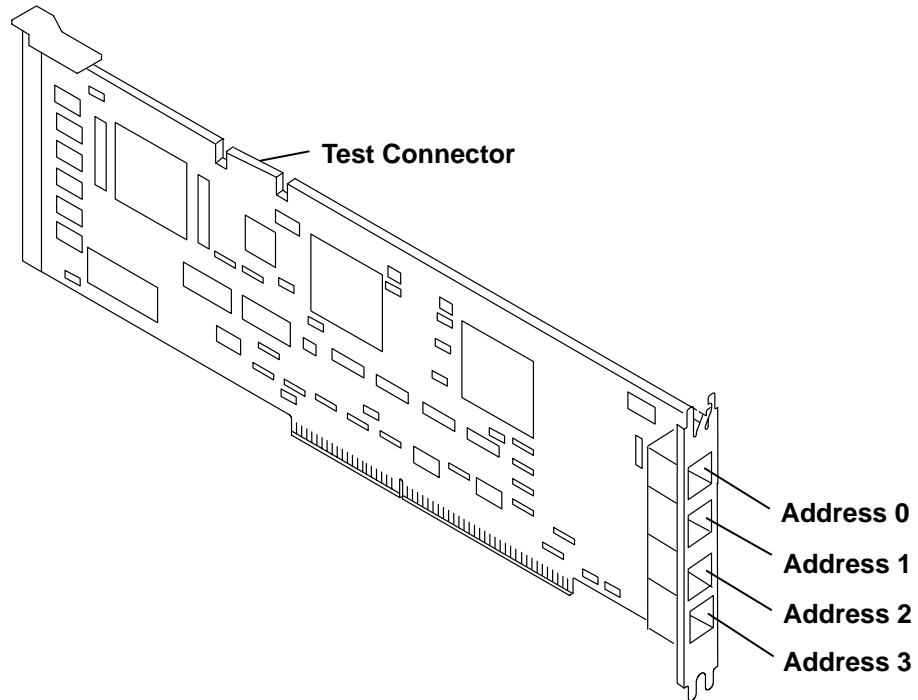

High Performance Disk Drive Subsystem Adapter (80M Byte/S) Specifications

FRU number	00G3357
Bus architecture	Micro Channel
Maximum number	1 (7013/580) 7 (7015/970/980)
Microcode filename	8f78.xx.xx
Data transfer rate	80 MB/second
Connector	6-position, serial link
Cables	Serial link, 9333 attachment, 10m (33 ft.) 07G4859 Serial link, 9333 attachment, 3m (10 ft.) 07G4860

Note: This adapter should be located in Slots 1 through 4. When this adapter is reported to have failed, check its slot position before replacing; if it is mounted in Slots 5 through 8, relocate the adapter to Slots 1 through 4, and try again.

High Performance Disk Drive Subsystem Adapter (80M Byte/S) Connector

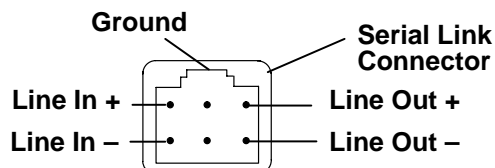

FC (2416) SCSI-2 Differential Fast/Wide Adapter/A (Type 4-6)

Note:

Small Computer Systems Interface is abbreviated as SCSI in this publication. **SCSI-2 Differential F**

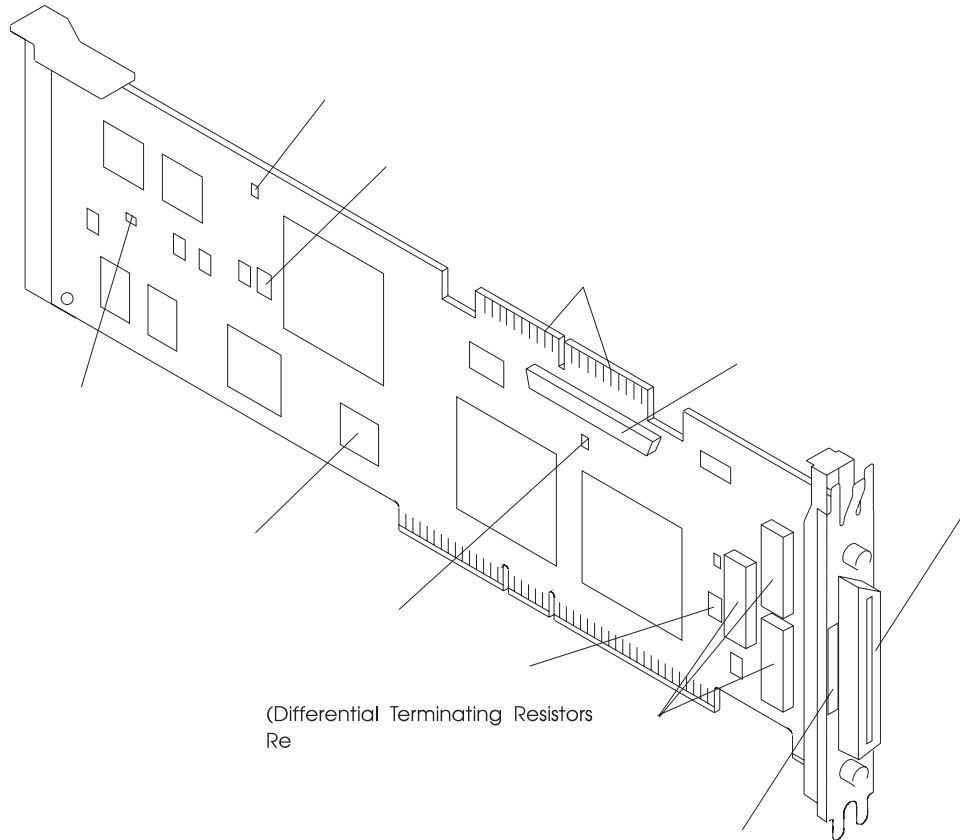

SCSI-2 Differential Fast/Wide Adapter/A Connectors

The SCSI-2 Differential Fast/Wide Adapter/A supports an internal single-ended and an external differential SCSI bus.

There are two connectors provided for attaching to the internal SCSI bus.

The 50-pin card edge connector is used for attaching a narrow (8-bit) SCSI cable. The 68-pin connector is used for attaching a wide (16-bit) SCSI cable. Refer to illustration “FC (2416) SCSI-2 Differential Fast/Wide Adapter/A (Type 4-6)” on page 1-106.

Note: Only one internal connector can have a cable attached at a time.

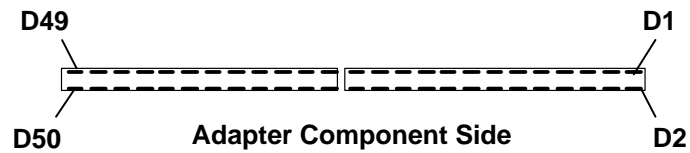

Signal Name	Pin	Pin	Signal Name
Ground	1	2	-DB(0)
Ground	3	4	-DB(1)
Ground	5	6	-DB(2)
Ground	7	8	-DB(3)
Ground	9	10	-DB(4)
Ground	11	12	-DB(5)
Ground	13	14	-DB(6)
Ground	15	16	-DB(7)
Ground	17	18	-DB(P)
Ground	19	20	Ground
Ground	21	22	Ground
Reserved*	23	24	Reserved*
Open	25	26	TERMPWR
Reserved*	27	28	Reserved*
Ground	29	30	Ground
Ground	31	32	-ATN
Ground	33	34	Ground
Ground	35	36	-BSY
Ground	37	38	-ACK
Ground	39	40	-RST
Ground	41	42	-MSG
Ground	43	44	-SEL
Ground	45	46	-C/D
Ground	47	48	-REQ
Ground	49	50	-I/O

Internal 68-Position 16-Bit Single-Ended High-Density SCSI Bus Connector (J1)

The following table shows the pinouts for the internal 68-pin SCSI connector.

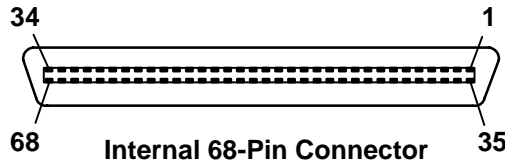

Signal Name	Pin	Pin	Signal Name
Ground	1	35	-DB(12)
Ground	2	36	-DB(13)
Ground	3	37	-DB(14)
Ground	4	38	-DB(15)
Ground	5	39	-DB(P1)
Ground	6	40	-DB(0)
Ground	7	41	-DB(1)
Ground	8	42	-DB(2)
Ground	9	43	-DB(3)
Ground	10	44	-DB(4)
Ground	11	45	-DB(5)
Ground	12	46	-DB(6)
Ground	13	47	-DB(7)
Ground	14	48	-DB(P)
Ground	15	49	Ground
Ground	16	50	Ground
TERMPWR	17	51	TERMPWR
TERMPWR	18	52	TERMPWR
Reserved	19	53	Reserved
Ground	20	54	Ground
Ground	21	55	-ATN
Ground	22	56	Ground
Ground	23	57	-BSY
Ground	24	58	-ACK
Ground	25	59	-RST
Ground	26	60	-MSG
Ground	27	61	-SEL
Ground	28	62	-C/D
Ground	29	63	-REQ
Ground	30	64	-I/O
Ground	31	65	-DB(8)
Ground	32	66	-DB(9)
Ground	33	67	-DB(10)
Ground	34	68	-DB(11)

External 68-Position 16-Bit Differential High-Density SCSI Bus Connector

The following table shows the pinouts for the external 68-pin differential SCSI connector.

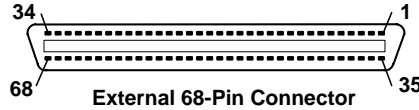

This connector is not the SCSI-2 standard 68-position connector. To attach cables with "P" type connectors, use interposer P/N 50G0460.

Signal Name	Pin	Pin	Signal Name
+DB(12)	1	35	-DB(12)
+DB(13)	2	36	-DB(13)
+DB(14)	3	37	-DB(14)
+DB(15)	4	38	-DB(15)
+DB(1)	5	39	-DB(P1)
Ground	6	40	Ground
+DB(0)	7	41	-DB(0)
+DB(1)	8	42	-DB(1)
+DB(2)	9	43	-DB(2)
+DB(3)	10	44	-DB(3)
+DB(4)	11	45	-DB(4)
+DB(5)	12	46	-DB(5)
+DB(6)	13	47	-DB(6)
+DB(7)	14	48	-DB(7)
+DB(P)	15	49	-DB(P)
DIFFSENS	16	50	Ground
TERMPWR	17	51	TERMPWR
TERMPWR	18	52	TERMPWR
Reserved	19	53	Reserved
+ATN	20	54	-ATN
Ground	21	55	Ground
+BSY	22	56	-BSY
+ACK	23	57	-ACK
+RST	24	58	-RST
+MSG	25	59	-MSG
+SEL	26	60	-SEL
+C/D	27	61	-C/D
+REQ	28	62	-REQ
+I/O	29	63	-I/O
Ground	30	64	Ground
+DB(8)	31	65	-DB(8)
+DB(9)	32	66	-DB(9)
+DB(10)	33	67	-DB(10)
+DB(11)	34	68	-DB(11)

FC (2415) SCSI-2 Fast/Wide Adapter/A (Type 4-7)

Note: Small Computer Systems Interface is abbreviated as SCSI in this publication.

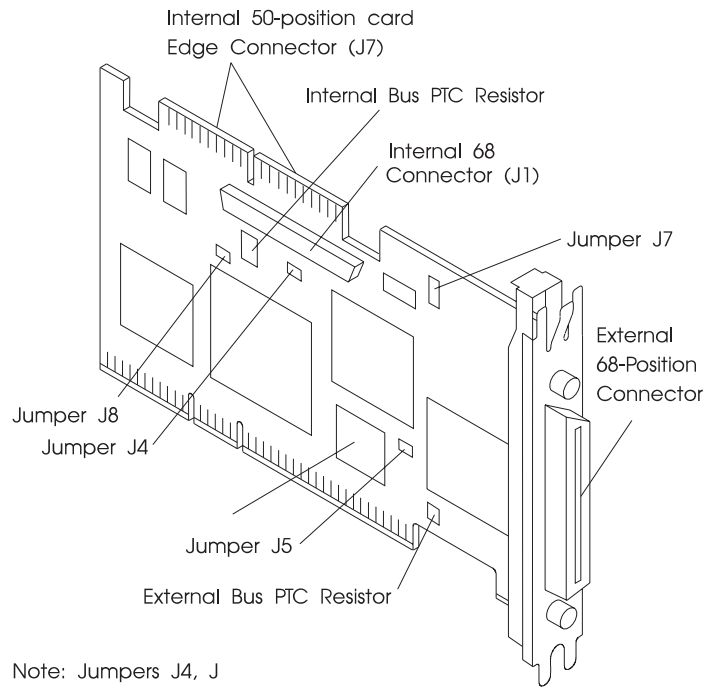

SCSI-2 Fast/Wide Adapter/A Connectors

The SCSI-2 Fast/Wide Adapter/A supports two single-ended SCSI busses (internal and external).

There are two connectors provided for attaching to the internal SCSI bus. The 50-pin card edge connector is used for attaching a narrow (8-bit) SCSI cable. The 68-pin connector is used for attaching a wide (16-bit) SCSI cable. Refer to illustration "FC (2415) SCSI-2 Fast/Wide Adapter/A (Type 4-7)" on page 1-110.

Note: Only one internal connector can have a cable attached at a time.

Internal 50-Position Card Edge SCSI Bus Connector

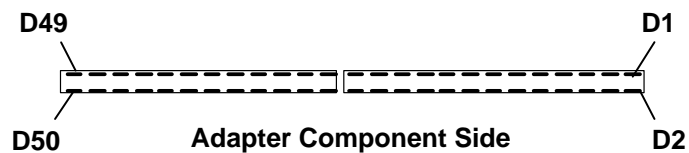

Signal Name	Pin	Pin	Signal Name
Ground	1	2	-DB(0)
Ground	3	4	-DB(1)
Ground	5	6	-DB(2)
Ground	7	8	-DB(3)
Ground	9	10	-DB(4)
Ground	11	12	-DB(5)
Ground	13	14	-DB(6)
Ground	15	16	-DB(7)
Ground	17	18	-DB(P)
Ground	19	20	Ground
Ground	21	22	Ground
Reserved*	23	24	Reserved*
Open	25	26	TERMPWR
Reserved*	27	28	Reserved*
Ground	29	30	Ground
Ground	31	32	-ATN
Ground	33	34	Ground
Ground	35	36	-BSY
Ground	37	38	-ACK
Ground	39	40	-RST
Ground	41	42	-MSG
Ground	43	44	-SEL
Ground	45	46	-C/D
Ground	47	48	-REQ
Ground	49	50	-I/O

Internal, External 68-Position 16-Bit Single-Ended High-Density SCSI Bus Connector

The following table shows the pinouts for the internal and external 68-pin SCSI connectors. The external connector is not the SCSI-2 standard 68-pin shielded, high density connector.

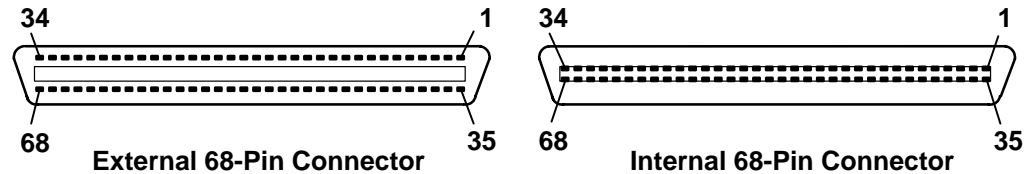

Signal Name	Pin	Pin	Signal Name
Ground	1	35	-DB(12)
Ground	2	36	-DB(13)
Ground	3	37	-DB(14)
Ground	4	38	-DB(15)
Ground	5	39	-DB(P1)
Ground	6	40	-DB(0)
Ground	7	41	-DB(1)
Ground	8	42	-DB(2)
Ground	9	43	-DB(3)
Ground	10	44	-DB(4)
Ground	11	45	-DB(5)
Ground	12	46	-DB(6)
Ground	13	47	-DB(7)
Ground	14	48	-DB(P)
Ground	15	49	Ground
Ground	16	50	Ground
TERMPWR	17	51	TERMPWR
TERMPWR	18	52	TERMPWR
Reserved	19	53	Reserved
Ground	20	54	Ground
Ground	21	55	-ATN
Ground	22	56	Ground
Ground	23	57	-BSY
Ground	24	58	-ACK
Ground	25	59	-RST
Ground	26	60	-MSG
Ground	27	61	-SEL
Ground	28	62	-C/D
Ground	29	63	-REQ
Ground	30	64	-I/O
Ground	31	65	-DB(8)
Ground	32	66	-DB(9)
Ground	33	67	-DB(10)
Ground	34	68	-DB(11)

FC (6212) High-Performance Disk Drive Subsystem Adapter (40/80M Byte/S) (Type 4-8)

This adapter provides an interface between 9333 Models 010, 011, 500 or 501 High-Performance Disk Drive Subsystems and a system unit.

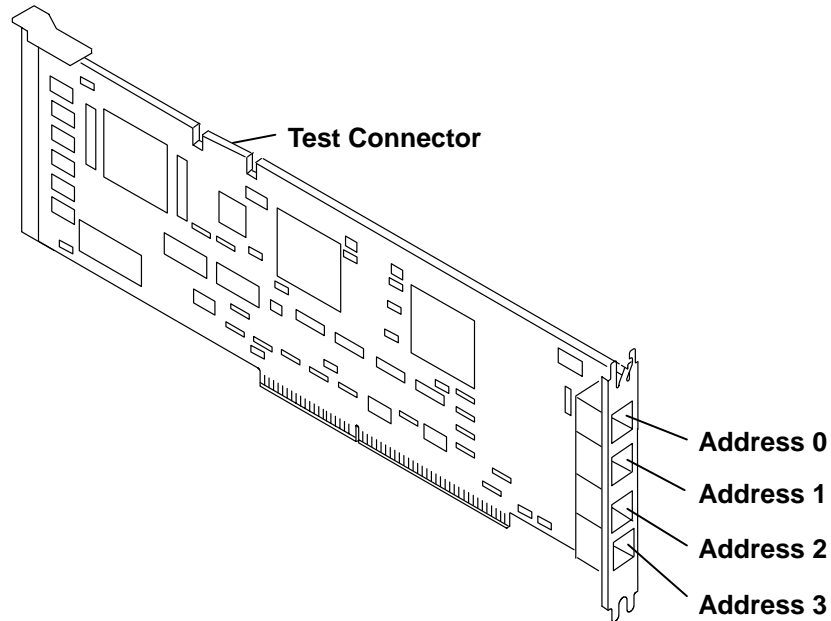

High-Performance Disk Drive Subsystem Adapter (40/80M Byte/S) Specifications

FRU number	88G3629
Bus architecture	Micro Channel
Maximum number	1 (7013/580) 7 (7015/970/980)
Microcode filename	8f78.xx.xx
Data transfer rate	80 MB/second
Connector	6-position, serial link
Cables	Serial link, 9333 attachment, 10 m (33 ft.) 07G4859 Serial link, 9333 attachment, 3 m (10 ft.) 07G4860

Note: This adapter should be located in Slots 1 through 4. When this adapter is reported to have failed, check its slot position before replacing; if it is mounted in Slots 5 through 8, relocate the adapter to Slots 1 through 4 and try again.

High-Performance Disk Drive Subsystem Adapter (40/80M Byte/S) Connector

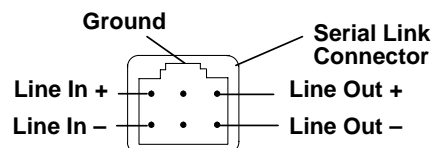

FC (2412) Enhanced SCSI-2 Differential Fast/Wide Adapter/A (Type 4-C)

Note: Small Computer Systems Interface is abbreviated as SCSI in this publication.

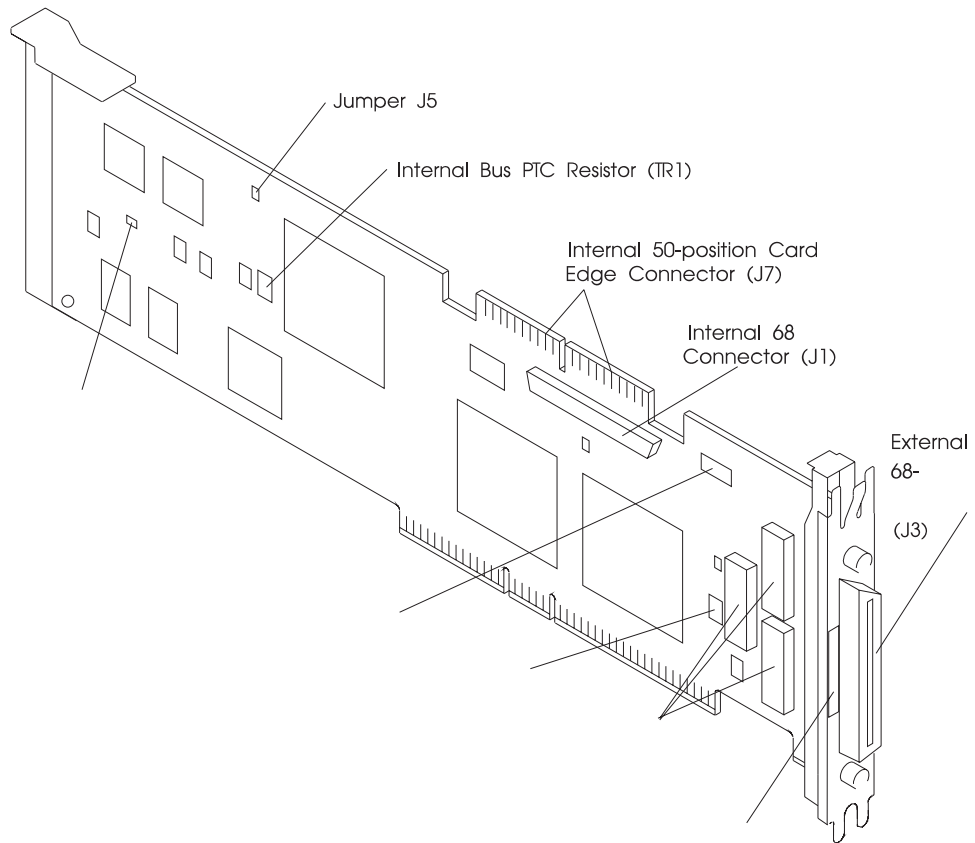

SCSI-2 Differential Fast/Wide Adapter/A Connectors

The SCSI-2 Differential Fast/Wide Adapter/A supports an internal single-ended and an external differential SCSI bus.

There are two connectors provided for attaching to the internal SCSI bus.

The 50-pin card edge connector is used for attaching a narrow (8-bit) SCSI cable. The 68-pin connector is used for attaching a wide (16-bit) SCSI cable. Refer to illustration “FC (2412) Enhanced SCSI-2 Differential Fast/Wide Adapter/A (Type 4-C)” on page 1-114.

Note: Only one internal connector can have a cable attached at a time.

Internal 50-Position Card Edge SCSI Bus Connector (J2)

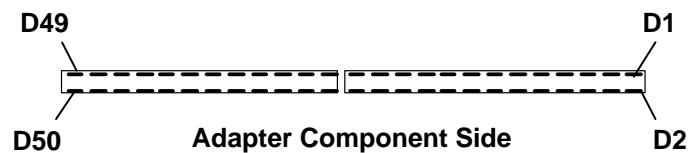

Signal Name	Pin	Pin	Signal Name
Ground	1	2	-DB(0)
Ground	3	4	-DB(1)
Ground	5	6	-DB(2)
Ground	7	8	-DB(3)
Ground	9	10	-DB(4)
Ground	11	12	-DB(5)
Ground	13	14	-DB(6)
Ground	15	16	-DB(7)
Ground	17	18	-DB(P)
Ground	19	20	Ground
Ground	21	22	Ground
Reserved	23	24	Reserved
Open	25	26	TERMPWR
Reserved	27	28	Reserved
Ground	29	30	Ground
Ground	31	32	-ATN
Ground	33	34	Ground
Ground	35	36	-BSY
Ground	37	38	-ACK
Ground	39	40	-RST
Ground	41	42	-MSG
Ground	43	44	-SEL
Ground	45	46	-C/D
Ground	47	48	-REQ
Ground	49	50	-I/O

Internal 68-Position 16-Bit Single-Ended High-Density SCSI Bus Connector (J1)

The following table shows the pinouts for the internal 68-pin SCSI connector.

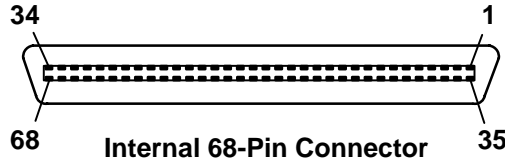

Signal Name	Pin	Pin	Signal Name
Ground	1	35	-DB(12)
Ground	2	36	-DB(13)
Ground	3	37	-DB(14)
Ground	4	38	-DB(15)
Ground	5	39	-DB(P1)
Ground	6	40	-DB(0)
Ground	7	41	-DB(1)
Ground	8	42	-DB(2)
Ground	9	43	-DB(3)
Ground	10	44	-DB(4)
Ground	11	45	-DB(5)
Ground	12	46	-DB(6)
Ground	13	47	-DB(7)
Ground	14	48	-DB(P)
Ground	15	49	Ground
Ground	16	50	Ground
TERMPWR	17	51	TERMPWR
TERMPWR	18	52	TERMPWR
Reserved	19	53	Reserved
Ground	20	54	Ground
Ground	21	55	-ATN
Ground	22	56	Ground
Ground	23	57	-BSY
Ground	24	58	-ACK
Ground	25	59	-RST
Ground	26	60	-MSG
Ground	27	61	-SEL
Ground	28	62	-C/D
Ground	29	63	-REQ
Ground	30	64	-I/O
Ground	31	65	-DB(8)
Ground	32	66	-DB(9)
Ground	33	67	-DB(10)
Ground	34	68	-DB(11)

External 68-Position 16-Bit Differential High-Density SCSI Bus Connector

The following table shows the pinouts for the external 68-pin differential SCSI connector.

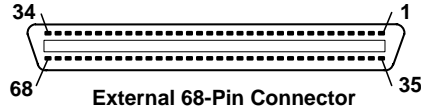

This connector is not the SCSI-2 standard 68-position connector. To attach cables with "P" type connectors, use interposer P/N 50G0460.

Signal Name	Pin	Pin	Signal Name
+DB(12)	1	35	-DB(12)
+DB(13)	2	36	-DB(13)
+DB(14)	3	37	-DB(14)
+DB(15)	4	38	-DB(15)
+DB(1)	5	39	-DB(P1)
Ground	6	40	Ground
+DB(0)	7	41	-DB(0)
+DB(1)	8	42	-DB(1)
+DB(2)	9	43	-DB(2)
+DB(3)	10	44	-DB(3)
+DB(4)	11	45	-DB(4)
+DB(5)	12	46	-DB(5)
+DB(6)	13	47	-DB(6)
+DB(7)	14	48	-DB(7)
+DB(P)	15	49	-DB(P)
DIFFSENS	16	50	Ground
TERMPWR	17	51	TERMPWR
TERMPWR	18	52	TERMPWR
Reserved	19	53	Reserved
+ATN	20	54	-ATN
Ground	21	55	Ground
+BSY	22	56	-BSY
+ACK	23	57	-ACK
+RST	24	58	-RST
+MSG	25	59	-MSG
+SEL	26	60	-SEL
+C/D	27	61	-C/D
+REQ	28	62	-REQ
+I/O	29	63	-I/O
Ground	30	64	Ground
+DB(8)	31	65	-DB(8)
+DB(9)	32	66	-DB(9)
+DB(10)	33	67	-DB(10)
+DB(11)	34	68	-DB(11)

FC (6214) SSA 4-Port Adapter (Type 4-D)

The SSA 4-Port Adapter serves as the interface between systems using the Micro Channel architecture and devices using the Serial Storage Architecture (SSA). The adapter provides 4 SSA ports for the attachment of storage devices such as hard disk drives. Each adapter card has four SSA connectors that are arranged in two pairs. Connectors A1 and A2 are one pair; connectors B1 and B2 are the other pair.

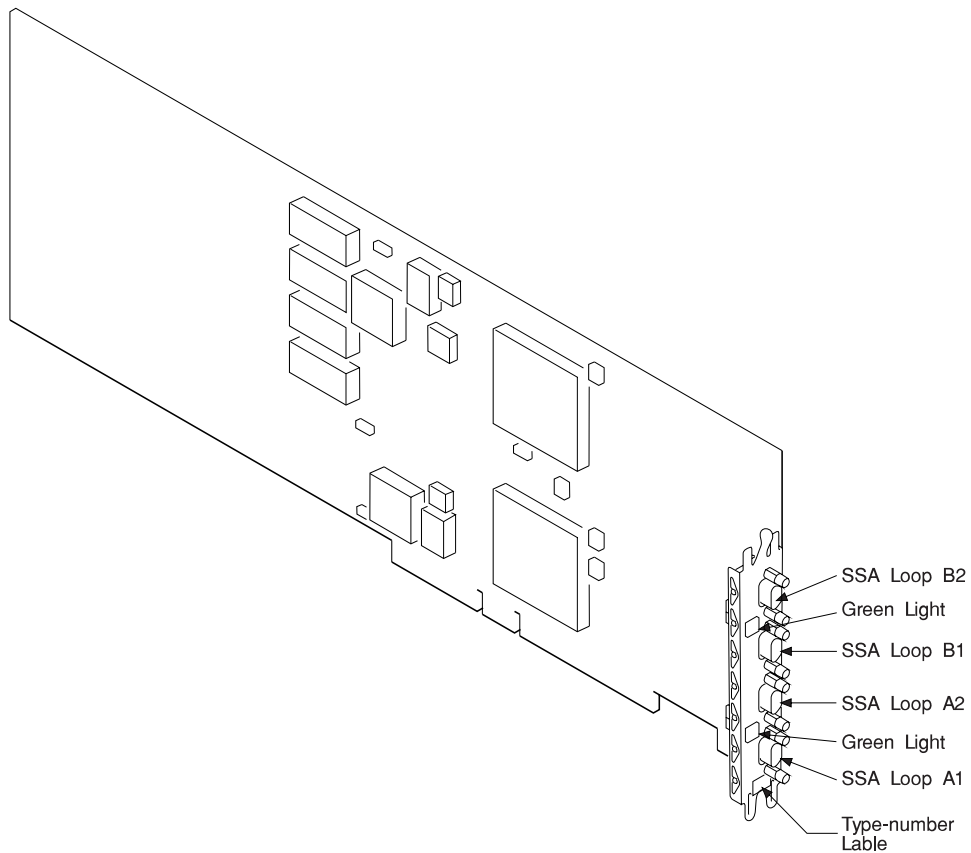

SSA 4-Port Adapter Specifications

FRU Number	11H3614
Maximum Number ¹	The maximum number of SSA adapters allowed is one half of maximum number of Micro Channel slots available in the system unit.
Bus architecture	Micro Channel
Busmaster	Yes
Adapter Type	5
Data transfer rate	40/80 MB/second
Connectors	9-position, subminiature D
Cables	Serial link

Note:

1. The maximum total number of SSA RAID adapters and SSA 4-Port adapters per system includes the following feature codes: 6214, 6216, 6217, and 6219.

Light Status

Each pair of connectors has a green light that indicates the operational status of its related loop:

Status of Light	Meaning
Off	Both SSA connectors are inactive. If disk drive modules or other SSA adapters are connected to these connectors, either those modules or adapters are failing, or their SSA links are not active.
Permanently on	Both SSA links are active (normal operating condition).
Slow Flash	Only one SSA link is active.

SSA 4-Port Adapter 9-Position Connector

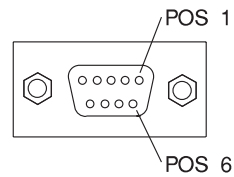

Position	Signal Name
1	Ground
2	- Line Out
3	Ground
4	- Line in
5	Ground
6	+ Line Out
7	Reserved
8	+ 5 V
9	+Line In

FC (6216) Enhanced SSA 4-Port Adapter (Type 4-G)

The Enhanced SSA 4-Port Adapter serves as the interface between systems using the Micro Channel architecture and devices using the Serial Storage Architecture (SSA). The adapter provides 4 SSA ports for the attachment of storage devices such as hard disk drives. Each adapter card has four SSA connectors that are arranged in two pairs. Connectors A1 and A2 are one pair; connectors B1 and B2 are the other pair. Enhanced SSA 4-port adapters support up to eight (8) initiators per loop.

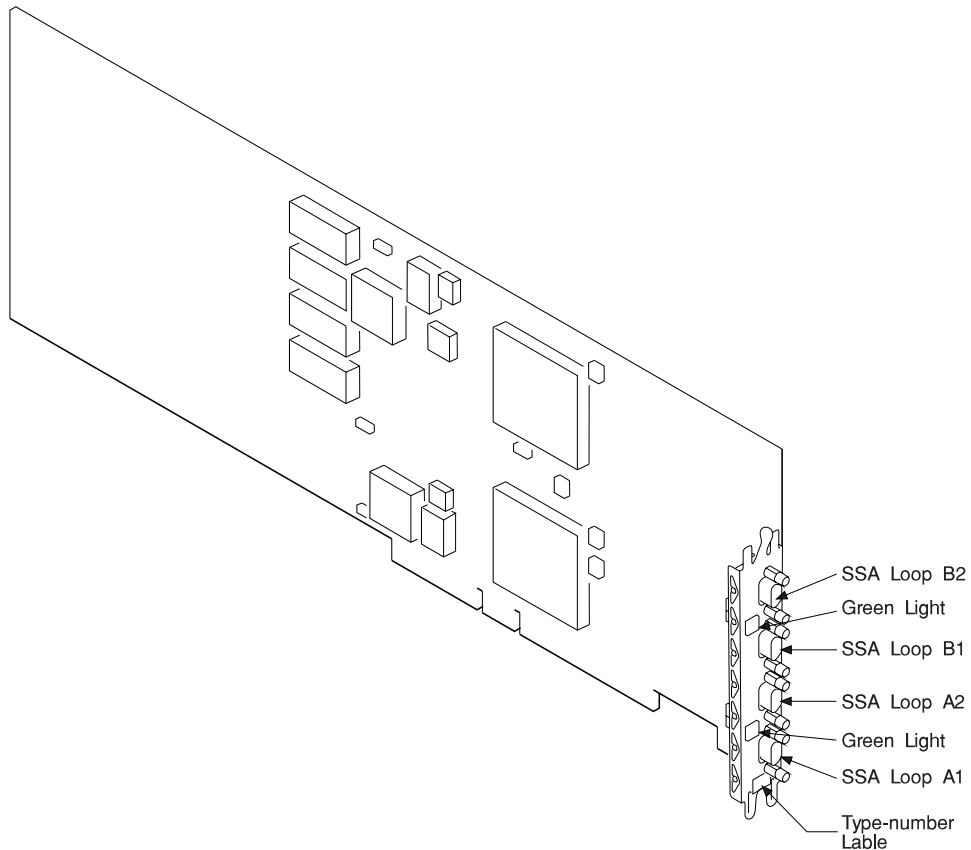

Enhanced SSA 4-Port Adapter Specifications

FRU Number	40H5707
Maximum Number ¹	The maximum number of SSA adapters allowed is one half of maximum number of Micro Channel slots available in the system unit.
Bus architecture	Micro Channel
Busmaster	Yes
Adapter Type	5
Data transfer rate	40/80 MB/second
Connector	9-position, subminiature D
Cables	Serial link

Note:

1. The maximum total number of SSA RAID adapters and SSA 4-Port adapters per system includes the following feature codes: 6214, 6216, 6217, and 6219.

Light Status

Each pair of connectors has a green light that indicates the operational status of its related loop:

Status of Light	Meaning
Off	Both SSA connectors are inactive. If disk drive modules or other SSA adapters are connected to these connectors, either those modules or adapters are failing, or their SSA links are not active.
Permanently on	Both SSA links are active (normal operating condition).
Slow Flash	Only one SSA link is active.

Enhanced SSA 4-Port Adapter 9-Position Connector

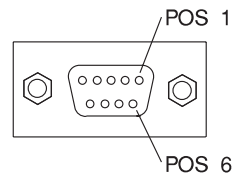

Position	Signal Name
1	Ground
2	- Line Out
3	Ground
4	- Line in
5	Ground
6	+ Line Out
7	Reserved
8	+ 5 V
9	+Line In

FC (6217) SSA 4-Port RAID Adapter (Type 4-I)

The SSA 4-Port RAID Adapter provides support for two SSA loops. Each loop can contain only one pair of adapter connectors and a maximum of 48 disk drives. For more information see *Micro Channel SSA RAID Adapter, Technical Reference*.

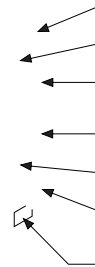
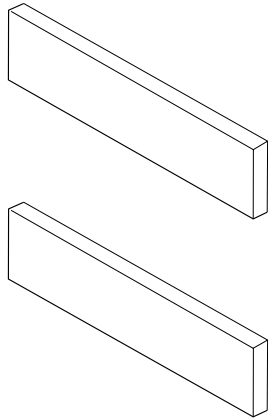

SSA 4-Port RAID Adapter Information

The adapter card has four SSA connectors that are arranged in two pairs. Connectors A1 and A2 are one pair; connectors B1 and B2 are the other pair.

The SSA links must be configured as loops. Each loop is connected to a pair of connectors at the SSA adapter card. These connectors *must* be a valid pair (that is, A1 and A2 or B1 and B2); otherwise, the disk drive modules on the loop are not fully configured, and the diagnostics fail. Operations to all the disk drive modules on a particular loop can continue if that loop breaks at any one point.

This adapter also contains *array management software* that provides RAID-5 functions to control the *arrays* of the RAID subsystem. An array can have from 3 to 16 *member disk drives*. Each array is handled as *one large disk* by the operating system. The array management software translates requests to this large disk into requests to the member disk drives. Although this adapter is a RAID adapter, it can be configured so that all, some, or none of the disk drives that are attached to it are member disks of arrays.

Lights of the SSA 4-Port RAID Adapter

Each pair of connectors has a green light that indicates the operational status of its related loop:

Status of Light	Meaning
Off	Both SSA connectors are inactive. If disk drive modules or other SSA adapters are connected to these connectors, either those modules or adapters are failing, or their SSA links are not active.
Permanently on	Both SSA links are active (normal operating condition).
Slow Flash	Only one SSA link is active.

SSA 4-Port RAID Adapter 9-Position Connector1569

FC (6219, 6222) Micro Channel SSA Multi-Initiator/RAID EL Adapter (Type 4-M) and SSA Fast-Write Cache Option

The Micro Channel SSA Multi-Initiator/RAID EL Adapter provides support for two SSA loops. Each loop can contain a maximum of 48 disk drives. If the fast-write cache or RAID functions of the adapter are used, no other adapter can be connected in an SSA loop with this adapter. If those functions are not used, a second Micro Channel SSA Multi-Initiator/RAID EL Adapter (or a PCI SSA Multi-Initiator/RAID EL Adapter) can be connected in the loop. To use the fast-write cache function, an SSA Fast-Write Cache Option Card (feature 6222) must be installed on the adapter card. For more information see *Micro Channel SSA RAID Adapters, Technical Reference*.

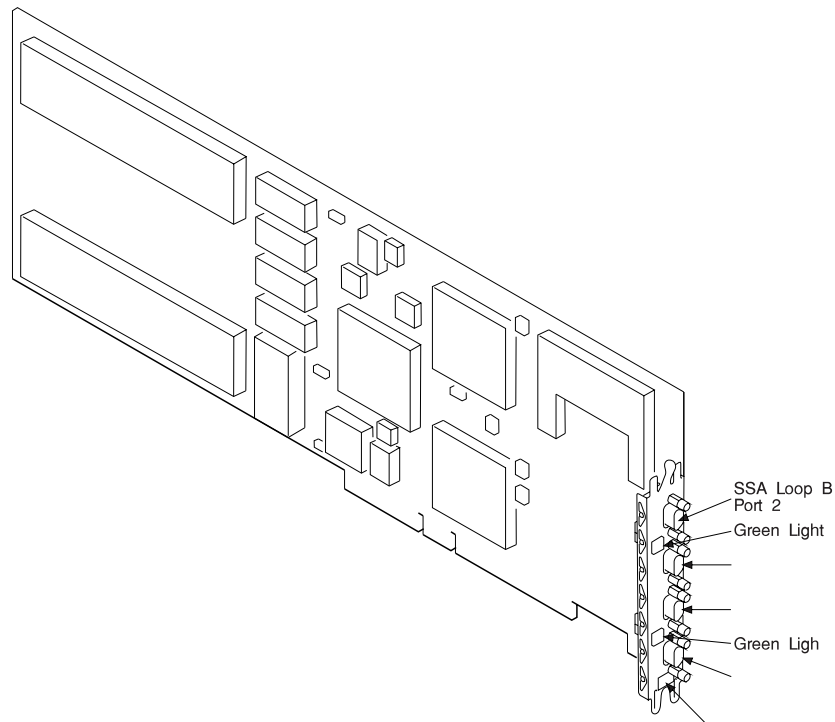

Micro Channel SSA Multi-Initiator/RAID EL Adapter Information

The adapter card has four SSA connectors that are arranged in two pairs. Connectors A1 and A2 are one pair; connectors B1 and B2 are the other pair.

The SSA links must be configured as loops. Each loop is connected to a pair of connectors at the SSA adapter card. These connectors *must* be a valid pair (that is, A1 and A2 or B1 and B2); otherwise, the disk drive modules on the loop are not fully configured, and the diagnostics fail. Operations to all the disk drive modules on a particular loop can continue if that loop breaks at any one point.

This adapter also contains *array management software* that provides RAID-5 functions to control the *arrays* of the RAID subsystem. An array can have from 3 to 16 *member disk drives*. Each array is handled as *one large disk* by the operating system. The array management software translates requests to this large disk into requests to the member disk drives. Although this adapter is a RAID adapter, it can be configured so that all, some, or none of the disk drives that are attached to it are member disks of arrays.

Other software in the adapter controls the Fast-Write Cache Option Card. This card provides 4MB of cache, which can improve performance for jobs that include many write operations. The fast-write cache card has a standard PCMCIA connector.

Lights of the Micro Channel Multi-Initiator/RAID EL Adapter

Each pair of connectors has a green light that indicates the operational status of its related loop:

Status of Light	Meaning
Off	Both SSA connectors are inactive. If disk drive modules or other SSA adapters are connected to these connectors, either those modules or adapters are failing, or their SSA links are not active.
Permanently on	Both SSA links are active (normal operating condition).
Slow Flash	Only one SSA link is active.

Micro Channel Multi-Initiator/RAID EL Adapter 9-Position Connector

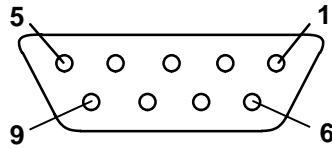

Position	Signal Name
1	Ground
2	- Line Out
3	Ground
4	- Line in
5	Ground
6	+ Line Out
7	Reserved
8	+ 5 V
9	+Line In

FC (2990) 3270 Connection (Type 5-1)

This adapter provides a way for the system units to communicate with a host computer.
This adapter responds to the host computer like a 3278 or 3279 Display.

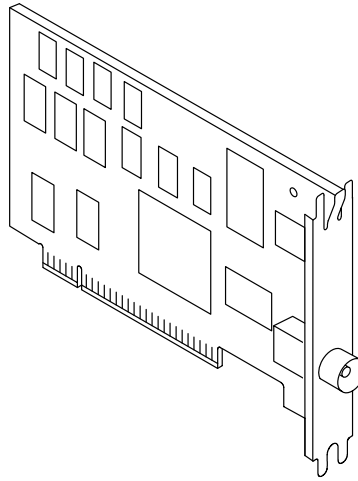

3270 Connection Specifications

FRU number	22F9743
Interrupt levels	9
Bus architecture	Micro Channel
Busmaster	No
Maximum number	4
Connector	BNC coaxial
Cable	Standard BNC coaxial.

FC (2755) Block Multiplexer Channel Adapter (Type 5-2)

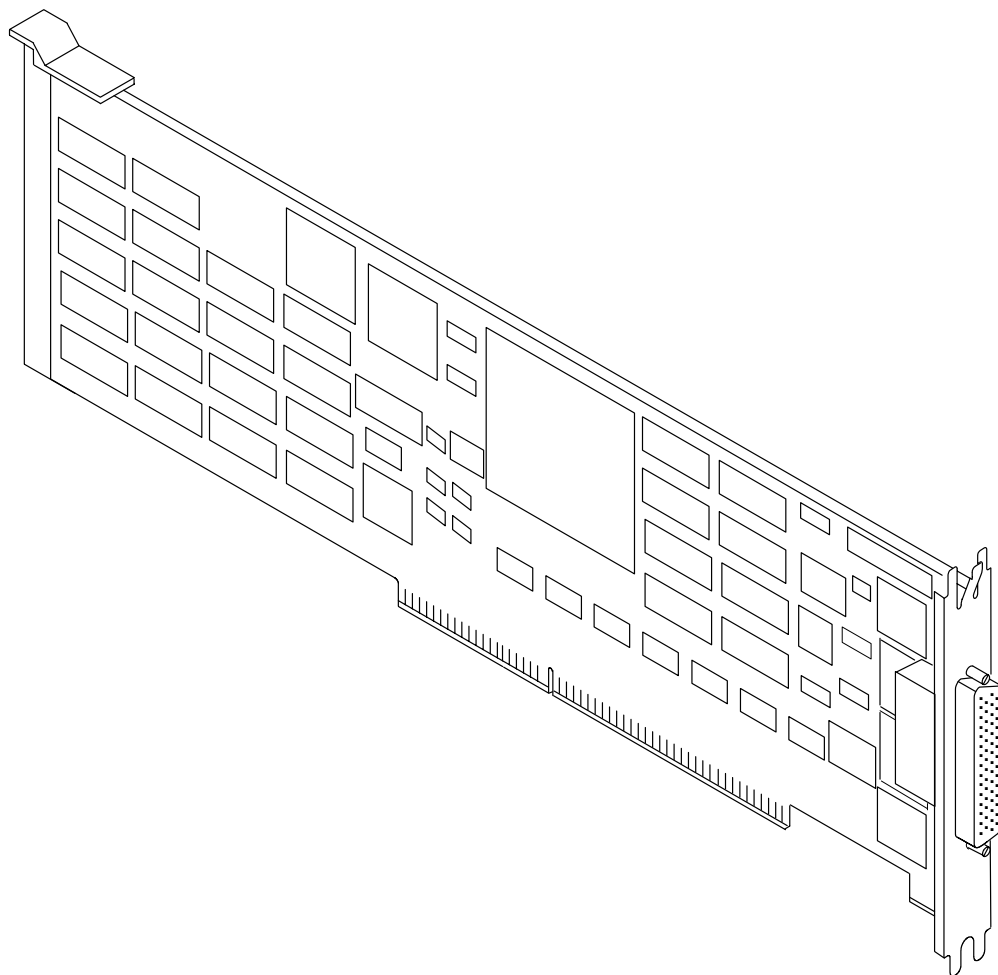

Block Multiplexer Channel Adapter Specifications

FRU number	02G7425
Bus architecture	Micro Channel
Maximum number	2
Microcode Filenames	fe92.xx.xx /etc/asw/cu3088b.xx.xx /etc/asw/cu3088e.xx.xx /etc/asw/cu3172b.xx.xx
Connector	78-position, D-shell, female
Cable	Adapter-to-interface assembly 92F6697
Interface Assembly	25F9401
Wrap Plugs	
Adapter	71F1184
Bus cable	8575337
Tag Cable	8575338

Block Multiplexer Channel Adapter Connector

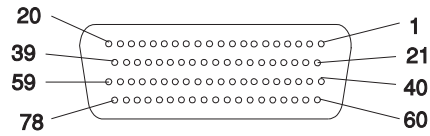

Note: All even-numbered pins are grounds.

Pin	Name	Description	Pin	Name	Description
1	Oplout	Operational Out	39	Busout1	Bus Out (bit 1)
3	Servout	Service Out	41	Adrout	Address Out
5	Mark0out	Mark 0 Out	43	Supout	Suppress Out
7	Adrin	Address In	45	Reserved	
9	Reqin	Request In	47	Srvin	Service In
11	Reserved		49	Mark0in	Mark 0 In
13	Busin5	Bus In (bit 5)	51	Busin7	Bus In (bit 7)
15	Busin1	Bus In (bit 1)	53	Busin3	Bus In (bit 3)
17	Busout6	Bus Out (bit 6)	55	Busoutp	Bus Out (parity)
19	Busout2	Bus Out (bit 2)	57	Busout4	Bus Out (bit 4)
21	Hldout	Hold Out	59	Busout0	Bus Out (bit 0)
23	Datout	Data Out	61	Cmdout	Command Out
25	Reserved		63	Selout	Select Out
27	Stain	Status In	65	Opin	Operational In
29	Selin	Select In	67	Datin	Data In
31	Businp	Bus In (parity)	69	Disin	Disconnect In
33	Busin4	Bus In (bit 4)	71	Busin6	Bus In (bit 6)
35	Busin0	Bus In (bit 0)	73	Busin2	Bus In (bit 2)
37	Busout5	Bus Out (bit 5)	75	Busout7	Bus Out (bit 7)
			77	Busout3	Bus Out (bit 3)

FC (2756) ESCON Channel Adapter (Type 5-3)

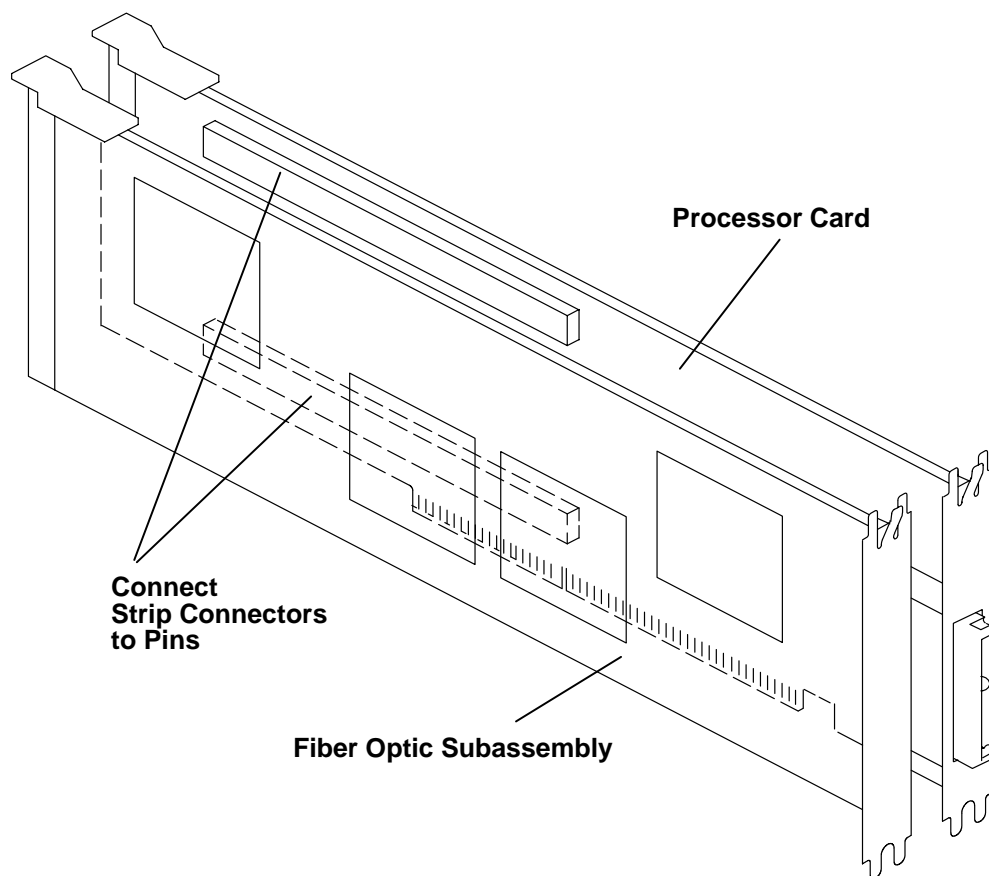

ESCON Channel Adapter Specifications

FRU numbers	Processor card 56G0294 Fiber optic subassembly 56G0295
Bus architecture	Micro Channel
Maximum number	2 (two slots required per adapter)
Microcode Filenames	c38fd.xx.xx c38f.clawn.std c38f.3088n.std c38f.xx.xx c38f.clawr.std c38f.mcm.con c38f.mcm.exe c38f.claws.std c38f.mcm.por c38f.3088s.std c38f.3088r.std c38f.mcm.postd
Connector	ESCON fiber connector
Fiber Cables	(duplex-to-duplex) 3.7 m (12 ft.) 74F5412 6.1 m (20 ft.) 74F5413 12.2 m (40 ft.) 74F5414 21.3 m (70 ft.) 74F5415 30.4 m (100 ft.) 74F5416 61 m (200 ft.) 74F5417 122 m (400 ft.) 74F5418
Wrap Plug	Fiber optic (included with adapter) 5605670

FC (2754) ESCON Channel Emulator Adapter (Type 5-3)

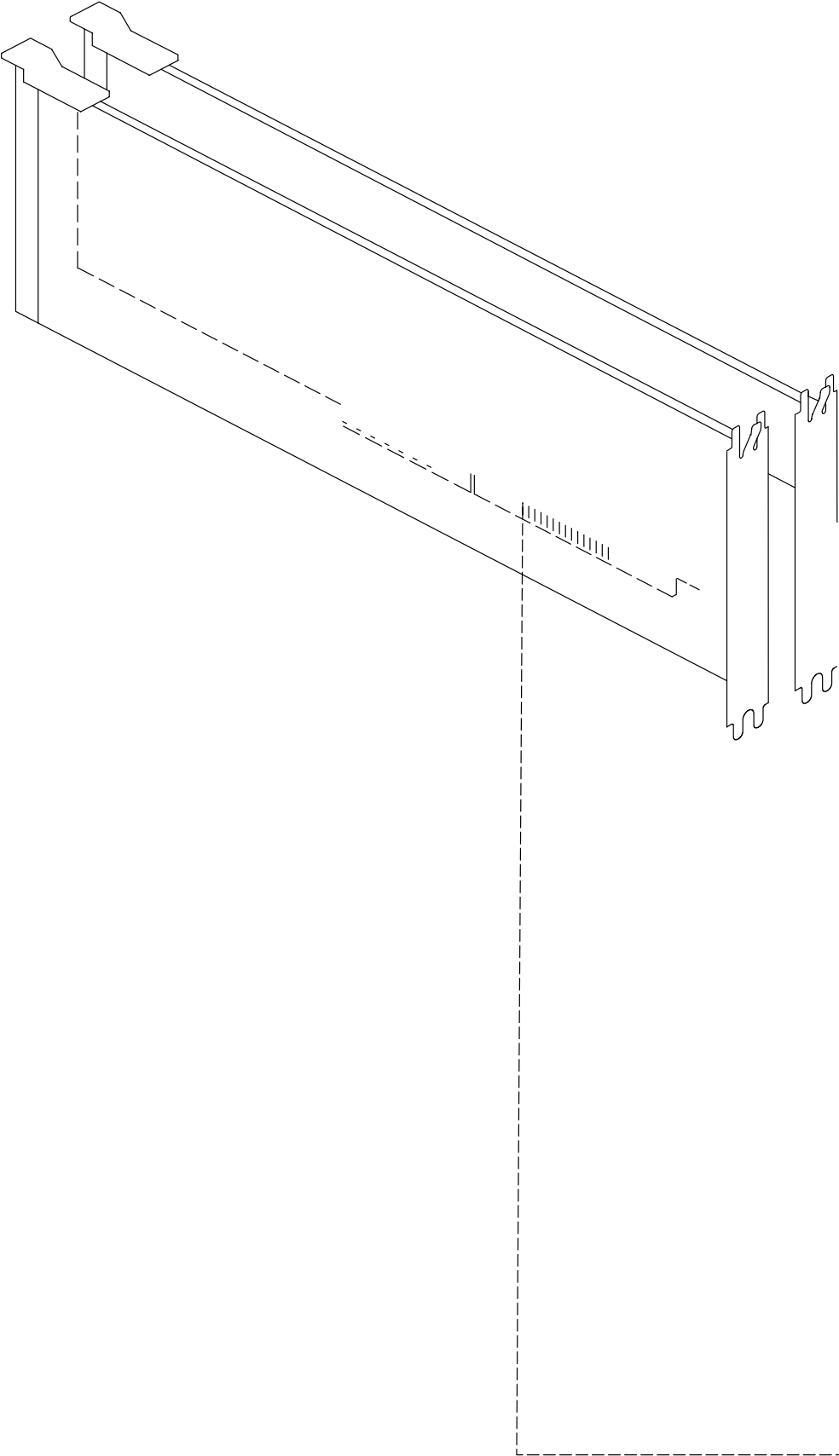

FC (2759) S/370 Channel Emulator/A (Type 5-4)

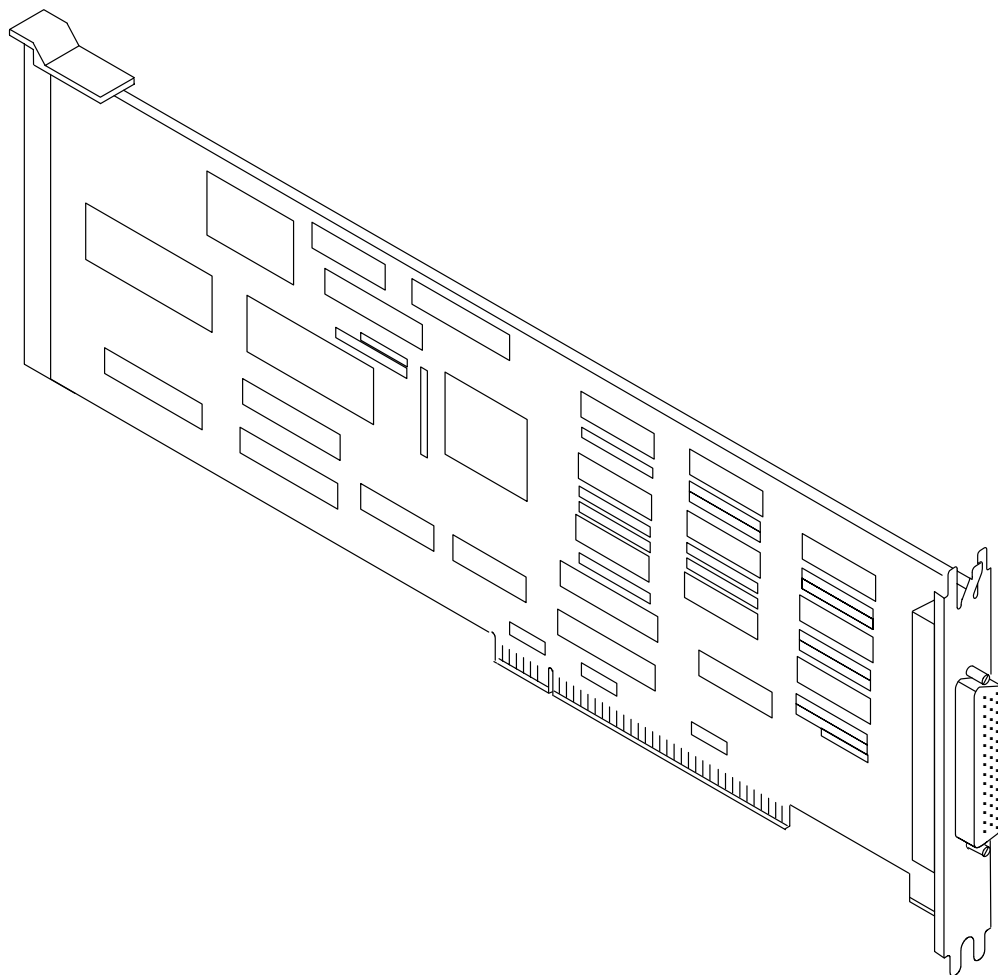

S/370 Channel Emulator/A Specifications

FRU number	65G1828
Bus architecture	Micro Channel
Maximum number	4
Connector	62-position, D-shell, female
Cable	Interface 68F7209
Wrap Plugs	
Bus cable	5479141
Tag Cable	5479139
Terminators	
Bus	2282675
Tag	2282676

S/370 Channel Emulator/A Connector

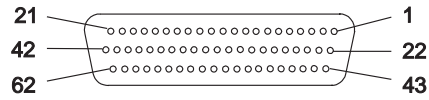

Pin	Name	Description	Pin	Name	Description
1	Busin	Bus In (parity)	16	Selin	Select In
2	Busin0	Bus In (bit 0)	17	Adrin	Address In
3	Busin1	Bus In (bit 1)	18	Markin	Mark In
4	Busin2	Bus In (bit 2)	19	Gnd	Ground
5	Busin3	Bus In (bit 3)	20	Gnd	Ground
6	Busin4	Bus In (bit 4)	21	Gnd	Ground
7	Busin5	Bus In (bit 5)	22	Gnd	Ground
8	Busin6	Bus In (bit 6)	23	Gnd	Ground
9	Busin7	Bus In (bit 7)	24	Gnd	Ground
10	Requin	Request In	25	Gnd	Ground
11	Srvin	Service In	26	Gnd	Ground
12	Stain	Status In	27	Gnd	Ground
13	Datin	Data In	28	Gnd	Ground
14	Opin	Operation In	29	Gnd	Ground
15	Disin	Disconnect In	30	Gnd	Ground
31	Gnd	Ground	47	Busout4	Bus Out (bit 4)
32	Gnd	Ground	48	Busout5	Bus Out (bit 5)
33	Gnd	Ground	49	Busout6	Bus Out (bit 6)
34	Gnd	Ground	50	Busout7	Bus Out (bit 7)
35	Gnd	Ground	51	Busoutp	Bus Out (parity)
36	Gnd	Ground	52	Adrout	Address Out
37	Gnd	Ground	53	Cmdout	Command Out
38	Gnd	Ground	54	Servout	Service Out
39	Gnd	Ground	55	Datout	Data Out
40	Gnd	Ground	56	Oplout	Operation Out
41	Gnd	Ground	57	Holdout	Hold Out
42	Gnd	Ground	58	Selector	Select Out
43	Busout0	Bus Out (bit 0)	59	Supprout	Suppress Out
44	Busout1	Bus Out (bit 1)	60	Gnd	Ground
45	Busout2	Bus Out (bit 2)	61	Gnd	Ground
46	Busout3	Bus Out (bit 3)	62	Gnd	Ground

FC (2810) Graphics Input Device Adapter (Type 6-1)

This adapter provides a way to attach the 6094 Model 10 Dials or the 6094 Model 20 Lighted Program Function Keyboard (LPFK) to the system units.

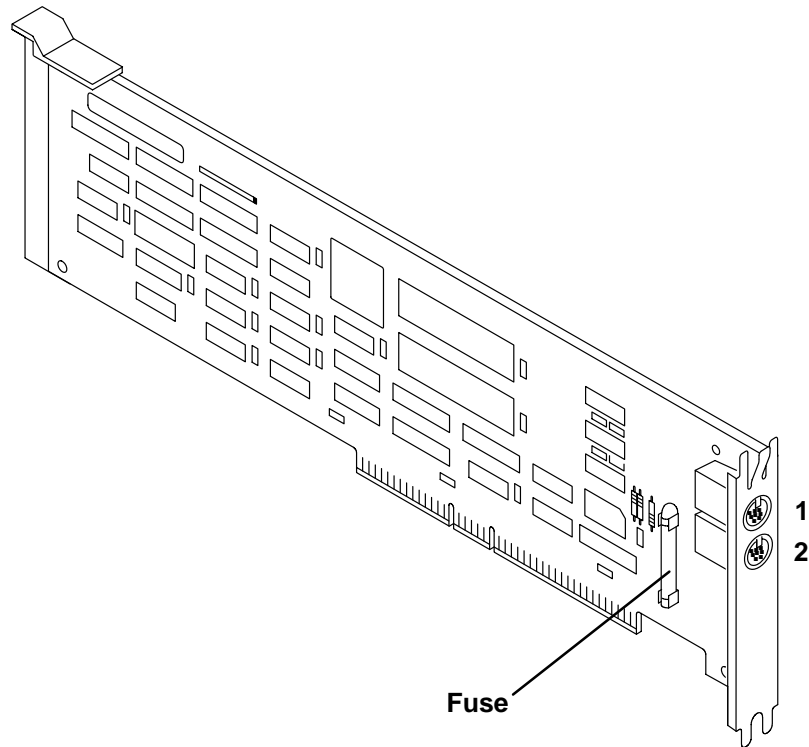

Graphics Input Device Adapter Specifications

FRU number	22F9758
Bus architecture	Micro Channel
I/O addresses	0960 - 0967, port A (1) 0968 - 096F, port B (2)
Interrupt levels	3, 4, 5, 6, 7, 9
Busmaster	No
Bits per character	5, 6, 7, 8 (set by program)
Bits per second	9600
Maximum number	1
Connectors	Two, 8-position DIN connectors
Fuse	Part number 0123786
Wrap plug	Dual connector 22F9689

Graphics Input Device Adapter Connectors

Two 8-position-DIN-connectors-pre-provided-for-attachment of-external device cables.
The signals-are-the same for-both-connectors.

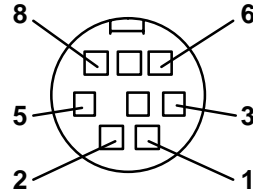

Position	Signal Name	Direction
1	Signal return	
2	Ground return	
3	+ 5 V dc	
4	Selective reset	To device
5	Receive data	From device
6	Transmit data	To device
7	Non-agnostic selective reset	From device
8	Reserved	

FC (2800) S/370 Host Interface Adapter (Type 6-2) or FC (2801, 2802) 5086/5085 Attachment Adapter

This adapter has two distinct modes of operation that correspond with the two Feature Codes for the same physical card. Different microcode accounts for the two different modes of operation. When the adapter is used in:

-hia mode

Referred to as the S/370 Host Interface Adapter (HIA), it allows support for the physical attachment of a system unit to any member of the family of the 5088/6098 Control Units via coaxial cable. It provides support for the AIX 5080 Emulation Program and Soft5080 for AIX.

-gsw mode

Referred to as the 5080 Attachment Adapter (AA), it provides a way to attach the 5080 Graphics Processor, the 5086 Graphics Processor, or the 5088/6098 Control Unit to the system units.

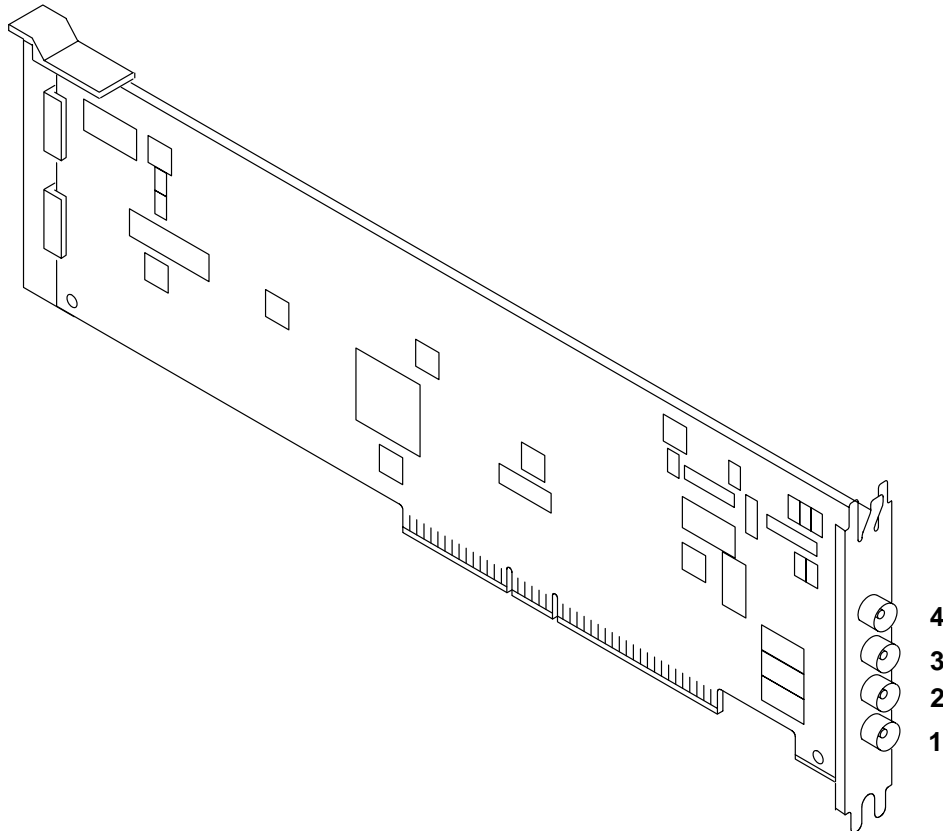

S/370 Host Interface Adapter / 5080 Attachment Adapter Specifications

FRU number	09G3667
I/O addresses	Assigned a 256 byte block of addresses, within any 64K byte block of addresses, in the first 16M bytes of memory
Interrupt levels	3, 4, 5, 6, 7, 9, 10, 11, 12, 14, 15 (set by the program)
Bus architecture	Micro Channel
Busmaster	No
Microcode file names	For AIX 3.2 and 4.1.3+ 8787S.00.01 8787P.00.01
Maximum number	one (1) AA adapter and as many HIA adapters as there are Micro Channel slots
Cable kits	Order part number 39F8201 to attach the 5085 Order part number 39F8202 to attach the 5086
Connector	Four BNC connectors (ensure that the same RG cable type is used throughout)

FC (none) Async Expansion Adapter (Type 6-3)

This adapter extends the Micro Channel bus from the CPU drawer to the async expansion drawer in the 7015 system unit. This card is sold only as part of the Async Expansion drawer.

This adapter extends only those signals needed to use asynchronous communication adapters in the expansion drawer.

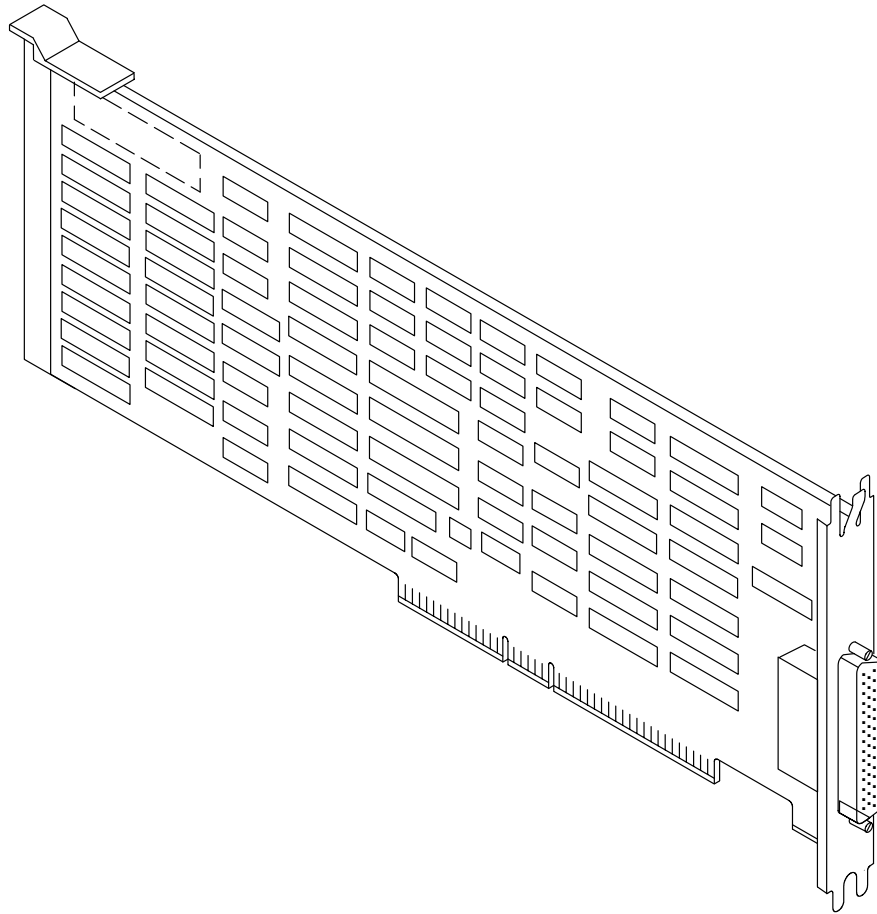

Async Expansion Adapter Specifications

FRU number	53F3621
Bus architecture	Micro Channel
Busmaster	No
Maximum number	1
Connector	78-position, D-shell
Cable	Part number 71F1379

FC (2860) Serial Optical Channel Converter (Type 6-4)

This adapter provides a high-speed communications method between system units through the serialization and deserialization (SERDES) of optical signals. Two independent, half-duplex optical paths are provided.

This adapter is certified as a Class 1 laser device. It contains an automatic shutdown control to prevent laser emissions; safety hazards are not present when the adapter is properly installed and connected. Port covers must be installed when a port is not connected.

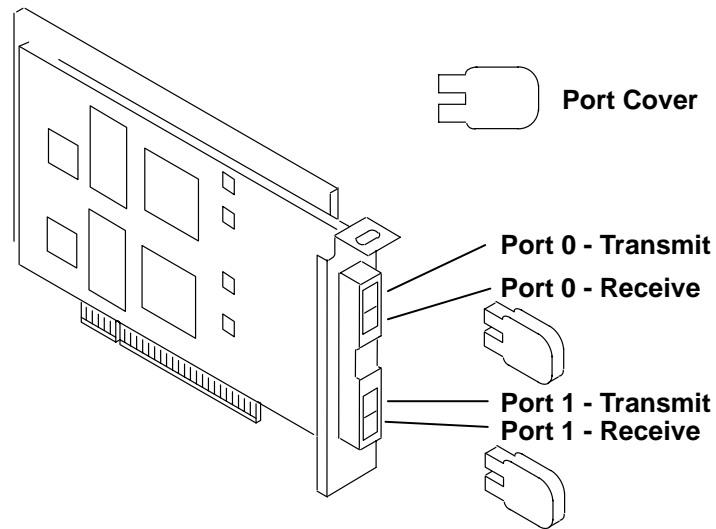

Serial Optical Channel Converter Specifications

FRU number	59F2969
Bus architecture	Special for serial optical channel converter
Maximum number	1 (7013 Models 520/530/540/550) 2 (7015 Models 930/950; 7016; 7018)
Cables	Optical cable, part number 21F9403 (6 m) Optical cable, part number 21F9405 (10 m) Optical cable, part number 21F9407 (20 m) Optical cable, part number 21F9410 (60 m) Optical cable, part number 21F9413 (100 m)
Fiber type/length restrictions	Minimum 4 m; Maximum 2K m
50/125 um	(10.5 db guaranteed user available link loss should not be exceeded for the 2K m supported length)
62.5/125 um	Minimum 4 m; Maximum 500 m (10.5 db guaranteed user available link loss should not be exceeded for any supported length)
Wrap plugs	Optical card, 56F0203, shipped with converter Fiber optic cable, 46F2438 Feed-through connector, 99F0489

FC (6300) Digital Trunk Adapter (Type 6-5)

This adapter is used to attach 9291/9295 Digital Trunk Processors to the system units.

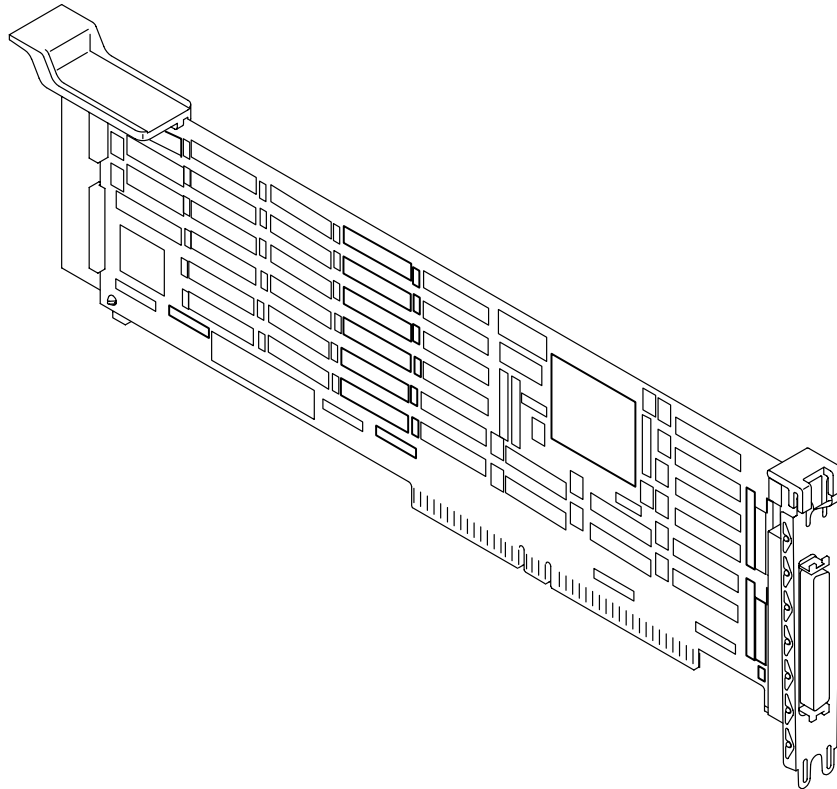

Digital Trunk Adapter Specifications

FRU number	54F0738
Bus architecture	Micro Channel
Microcode file name	none
Maximum number	3
Connector	25-pin D-shell (male pins on adapter)
Cable	adapter-to-9291/9295, 2 m (6.5 ft.) 34F0873
Wrap plug assemblies	
adapter/cable	25-pin Sub D-shell, female 34F0874
Enclosure trunk	15-pin Sub D-shell, male 34F0876
Telecommunications line	
CSU cable, T1 only	34F0875
Coax, CEPT* only	75-ohm, male-male, 61F5394
Coax, Network, CEPT* only	female-female, 75-ohm, 61F5395

* All countries except France

Note: For diagnostic procedures concerning this adapter and 9291/9295 machine types, refer to the *Direct Talk/6000 Problem Solving Guide*, order number SC22-0105.

Digital Trunk Adapter 25-Position Connector

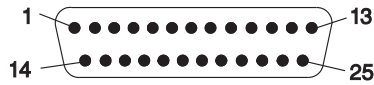

Position	Signal Name	Direction
1	+A0/+DB 0-8	Bidirectional
2	A1/+DB 1-9	Bidirectional
3	+A2/+DB 2-10	Bidirectional
4	+A3/+DB 3-11	Bidirectional
5	-CS1/+DB 4-12	Bidirectional
6	-Channel Reset	Out
7	-Host Interrupt (-HOST INT)	In
8	-Acknowledge (-ACK)	In
9	-VSC Present	In
10	-Command (-CMD)	Out
11	Status Register Bit 6 (Wrap)	In
12	+Byte Swap Request	Out
13	-Parity Enable	Out
14	NU1	-
15	NU2	-
16	-Wrap Plug Present	In
17	Status Register Bit 7 (Wrap)	In
18	Signal Ground	-
19	-Host Command	Out
20	-VSC Parity Error	In
21	Signal Ground	-
22	+R/-W/+DB 5-13	Bidirectional
23	+DB 6-14	Bidirectional
24	+DB 7-15	Bidirectional
25	Byte Parity	Bidirectional

FC (6305) Digital Trunk Dual Adapter (Type 6-6)

This adapter is used to attach the 9291/9295 Digital Trunk Processors to the system units.

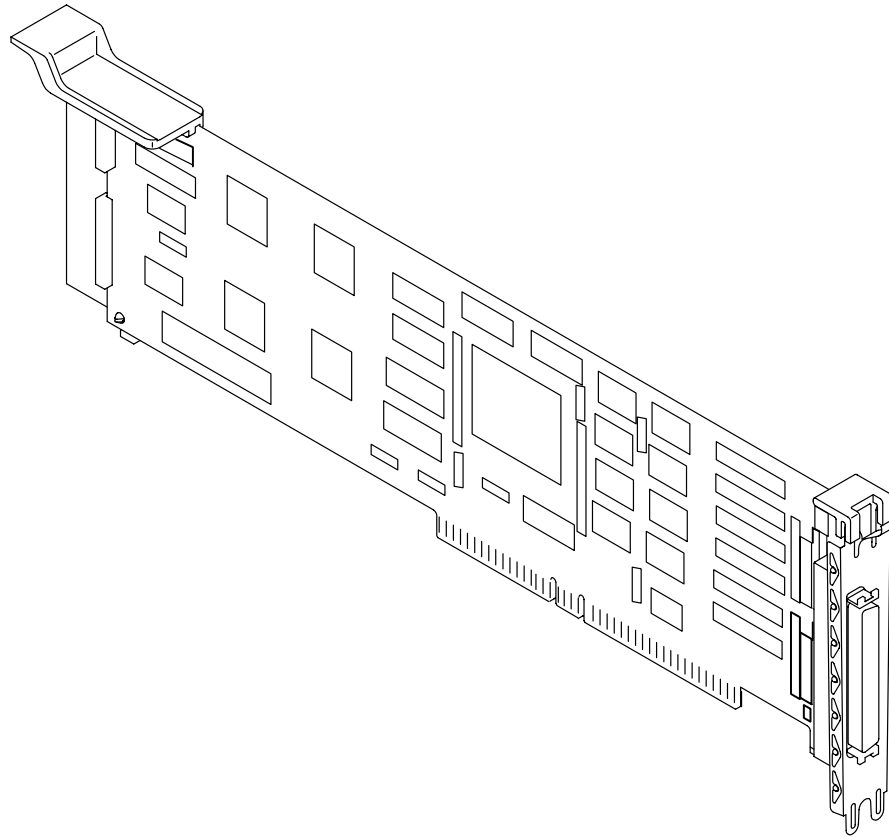

Digital Trunk Dual Adapter Specifications

FRU number	43G3317
Bus architecture	Micro Channel
Microcode file name	none
Maximum number	3
Connector	62-pin female
Cable, "Y"	adapter-to-9291/9295, 62-pin-to-two 25-pin D-shells, 20cm (7.9 in.) 43G3318
Wrap plug assemblies	
Enclosure trunk	15-pin Sub D-shell, male 34F0876
Telecommunications line	
CSU cable, T1 only	34F0875
Coax, CEPT* only	75-ohm, male-male, 61F5394
Coax, Network, CEPT* only	female-female, 75-ohm, 61F5395

* All countries except France

Digital Trunk Dual Adapter 62-Position Connector

Position	Signal Name	Direction
1	GND	Out
2	-VPACK #2 wrap plug present	In
3	-VPACK #2 status reg bit 7 (wrap)	In
4	-VPACK #2 status reg bit 6 (wrap)	In
5	-VPACK #2 parity enable	Out
6	+VPACK #2 DB 6-14	Bidirectional
7	+VPACK #2 A3/ +DB 3-11	Bidirectional
8	+VPACK #2 A0/ +DB 0-8	Bidirectional
9	no connection	
10	GND	Out
11	-VPACK #1 wrap plug present	In
12	-VPACK #1 status reg bit 7 (wrap)	In
13	-VPACK #1 status reg bit 6 (wrap)	In
14	-VPACK #1 parity enable	Out
15	+VPACK #1 DB 6-14	Bidirectional
16	+VPACK #1 A3/ +DB 3-11	Bidirectional
17	+VPACK #1 A0/ +DB 0-8	Bidirectional
18	no connection	
19	no connection	
20	no connection	
21	no connection	
22	GND	Out
23	-VPACK #2 channel reset	Out
24	-VPACK #2 host cmd	Out
25	+VPACK #2 byte swap req	Out
26	-VPACK #2 cmd	Out
27	+VPACK #2 DB 7-15	Bidirectional
28	-VPACK #2 CS/ +DB 4-12	Bidirectional
29	+VPACK #2 A1/ +DB 1-9	Bidirectional
30	no connection	
31	GND	Out
32	-VPACK #1 channel reset	Out
33	-VPACK #1 host cmd	Out
34	+VPACK #1 byte swap req	Out
35	-VPACK #1 cmd	Out
36	+VPACK #1 DB 7-15	Bidirectional
37	-VPACK #1 CS/ +DB 4-12	Bidirectional
38	+VPACK #1 A1/ +DB 1-9	Bidirectional
39	no connection	
40	no connection	
41	no connection	
42	no connection	
43	-VPACK #2 parity error	In
44	-VPACK #2 Acknowledge (ACK)	In
45	-VPACK #2 host interrupt	In
46	-VPACK #2 present	In
47	+VPACK #2 byte parity	Bidirectional
48	+VPACK #2 R/-W/ +DB 5-13	Bidirectional

Position	Signal Name	Direction
49	+VPACK #2 A2/ +DB 2-10	Bidirectional
50	no connection	
51	no connection	
52	-VPACK #1 parity error	
53	-VPACK #1 Acknowledge (ACK)	In
54	-VPACK #1 host interrupt	In
55	-VPACK #1 present	In
56	+VPACK #1 byte parity	Bidirectional
57	+VPACK #1 R/-W/ +DB 5-13	Bidirectional
58	+VPACK #1 A2/ +DB 2-10	Bidirectional
59	no connection	
60	no connection	
61	no connection	
62	no connection	

FC (2840) 5080 Coax Communications Adapter (Type 6-8)

This adapter is referred to as the 5080 Coax Communications Adapter (5080CCA). The adapter allows the physical attachment of a system unit to any member of the family of 5080/6090 Control Units via coaxial cable.

Its smaller size provides support for the AIX 5080 emulation program and Soft5080 for AIX on system units that cannot accommodate the larger adapter FC 2800.

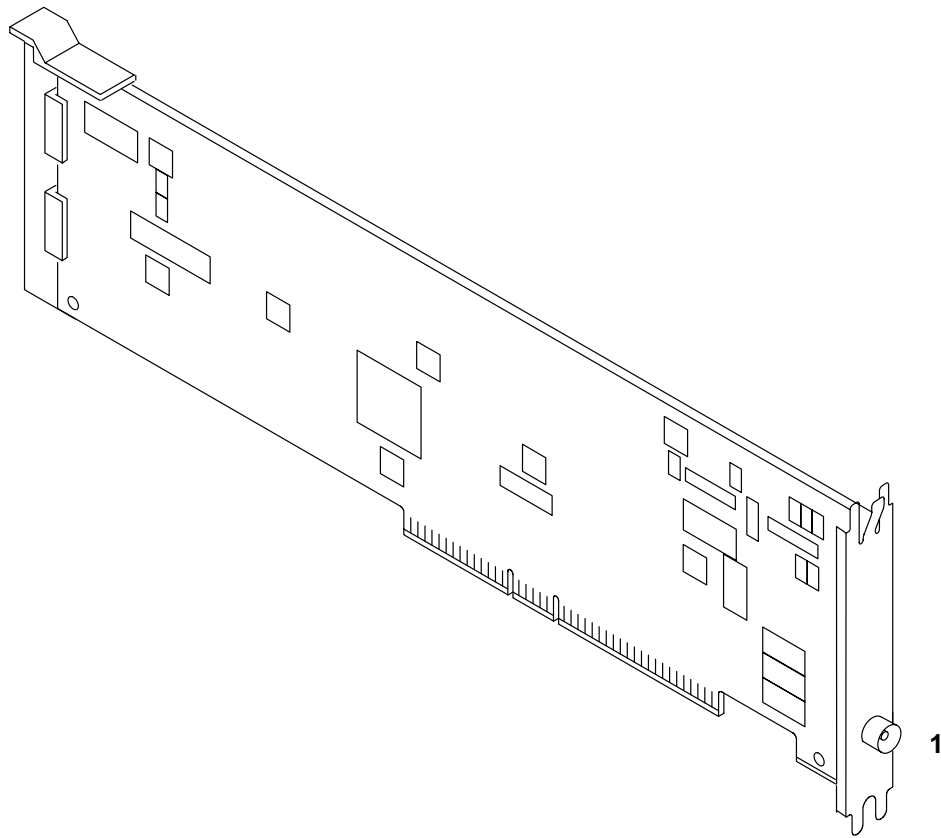

5080 Coax Communications Adapter Specifications

FRU number	88G2838
I/O addresses	Assigned a 256 byte block of addresses, within any 64K byte block of addresses, in the first 16M bytes of memory
Interrupt levels	3, 4, 5, 6, 7, 9, 10, 11, 12, 14, 15 (set by the program)
Bus architecture	Micro Channel
Busmaster	No
Microcode file names	For AIX 3.2 and 4.1.3+ 8787S.00.01
Maximum number	As many 5080 CCA adapters as there are Micro Channel slots
Cable	Standard BNC Coaxial Order part number 39F8202 to attach the 5086

FC (6301) M-Audio Capture and Playback Adapter (Type 7-1)

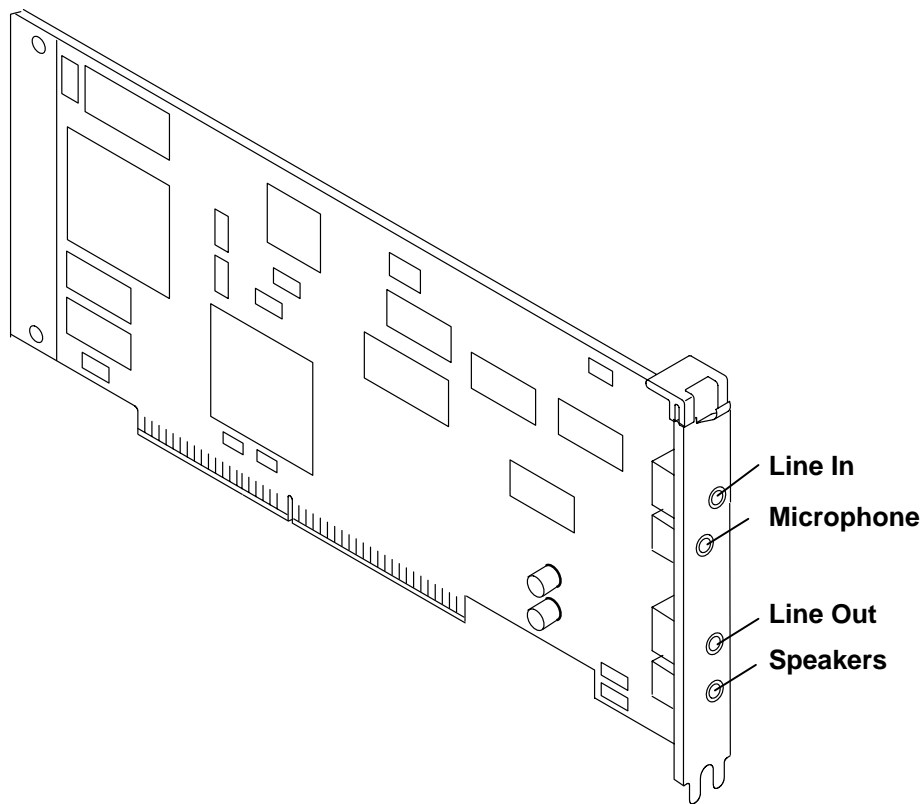

M-Audio Capture and Playback Adapter Specifications

FRU number	51G8018
Bus architecture	Micro Channel
Maximum number	4 (7012/7013/ 7016)
Connector	RCA jack, stereo
Microcode filenames	6c6e511p.xx.xx 6c6e511r.xx.xx 6c6epcmp.xx.xx 6c6epcmr.xx.xx 6c6e22p.xx.xx 6c6e22r.xx.xx
Microcode diskette assembly	32G1889

FC (2400) M-Video Capture Adapter (Type 7-2)

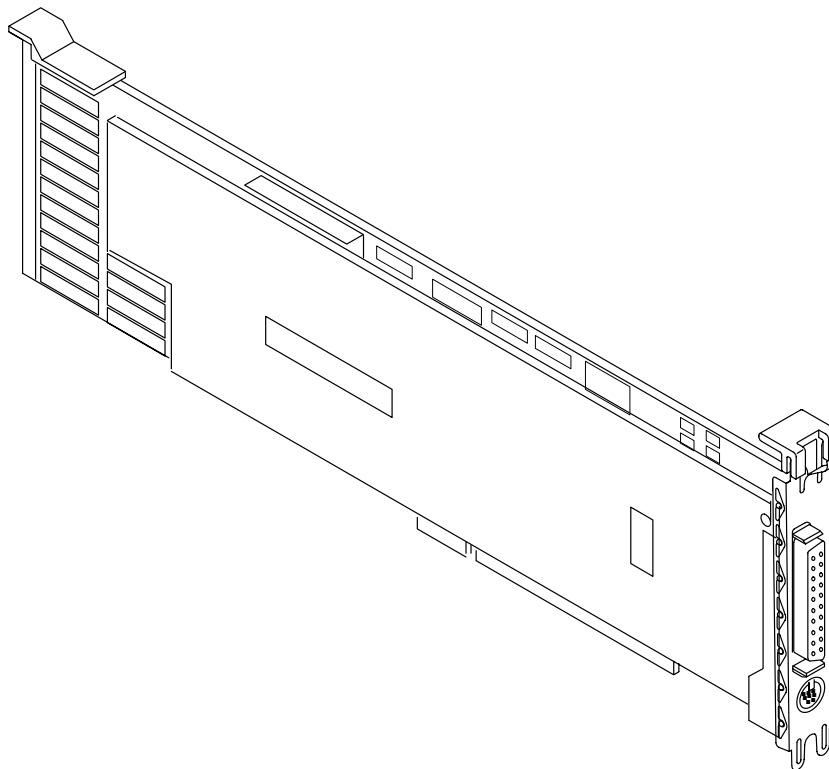

M-Video Capture Adapter (NTSC Version) Specifications

FRU number	32G0258
Bus architecture	Micro Channel
Maximum number	2
Connectors	20-position D-shell S-type
Cable set	92F3713, includes: Primary I/O S-Connector Wrap test (3) Terminator plugs (3), 75-ohm

M-Video Capture Adapter 20-Pin Connector

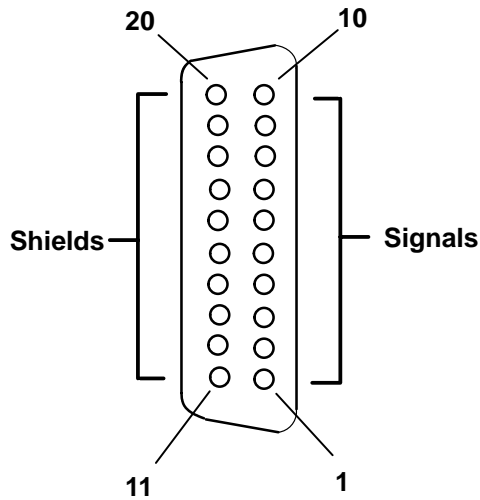

Note: The RCA plug ends of the Primary I/O cable are labelled with corresponding adapter signal pin numbers.

Position	Signal/Shield	RCA Plug Identifier
1/11	Composite Sync Output/Shield	1
2/12	Analog Blue Output/Shield	2
3/13	Analog Green Output/Shield	3
4/14	Analog Red Output/Shield	4
5/15	NTSC Output/Shield	5
6/16	Composite Sync Input/Shield	6
7/17	Analog Blue Input/Shield	7
8/18	Analog Green or Luma Input/Shield	8
9/19	Analog Red or Chroma Input/Shield	9
10/20	NTSC Input/Shield	10

M-Video Capture Adapter S-Connector

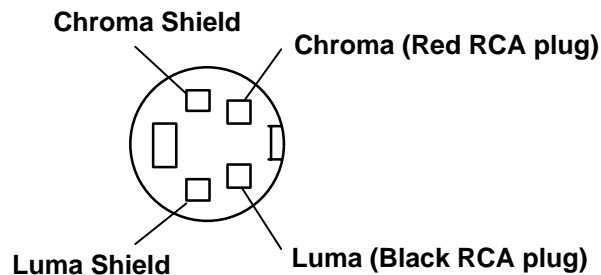

09 (PAL Ver) (Type 6) Capture Adapter (Type 7) Mini-DVI Adapter (PAL Ver)

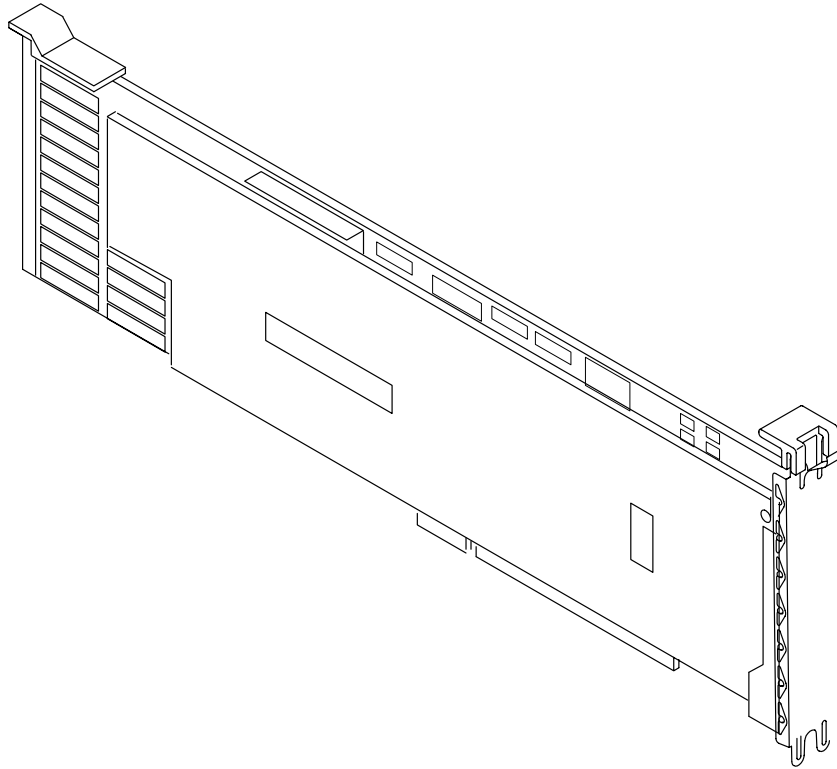

M-Video Capture Adapter 37-Pin Connector

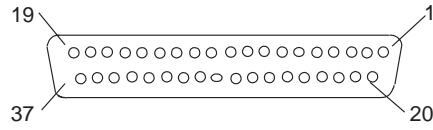

Position	Signal/Shield	RCA Plug Identifier
1/20 2/21 5/24 6/25	Y (Luma) Output/Shield C (Chroma) Output/Shield Sync Output/Shield Blue Output/Shield	OY OC OS OB
7/26 8/27 9/28 12/30	Green Output/Shield Red Output/Shield Composite Video Output/Shield Sync Input/Shield	OG OR OV IS
13/31 14/32 15/33 16/34	Blue Input/Shield Green /Luma Input/Shield Red /Chroma Input/Shield Composite Video Input/Shield	IB IG IR IV

FC (2404) Ultimedia Video I/O Adapter (Type 7-5)

This adapter provides video capture, video output.

The adapter supports NTSC, PAL, and S-Video inputs, and provides NTSC, PAL and S-Video outputs. One composite and one S-Video source may be installed simultaneously, with the program selecting the active video input signal.

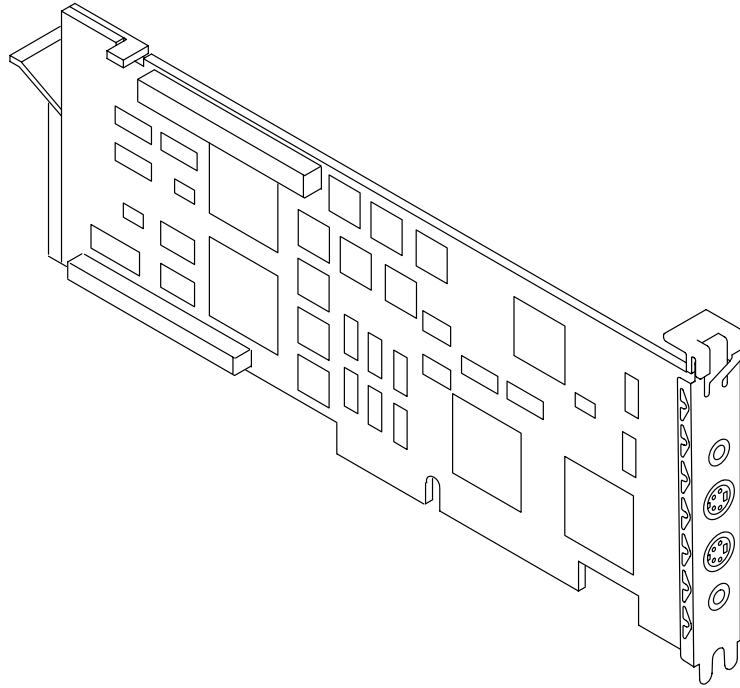

Ultimedia Video I/O Adapter Specifications

FRU number	Base Card, 88G3711
Bus architecture	Micro Channel
Maximum number	1
Connectors	Input 1 - RCA Jack-CVBS 1 - MiniDin S-Video Output 1 - RCA Jack-CVBS 1 - Mini Din S-Video
Connector	See "Ultimedia Video I/O Adapter Connector" on page 1-153
Cables	Supplied by Customer
Video Input Format	NTSC, PAL, S-Video
Mandatory Software	AIX/6000 Version 3.2.5 AIX Windows Environment/6000 Version 1.2.3 Ultimedia Service for AIX Version 1.2.1 or later or AIX/6000 Version 4.1 with AIXwindows 2D and SOMobject Base Tool Kit installed Ultimedia Services for AIX Version 2.1.1 or later

FC (2405) JPEG Compression Option shown Attached to the Ultimedia Video I/O Adapter (Type 7-5)

This adapter provides video capture, JPEG compression of video images, video output, and hardware decompression of JPEG data.

The adapter supports NTSC, PAL, and S-Video inputs, and provides NTSC, PAL and S-Video outputs. One composite and one S-Video source may be installed simultaneously, with the program selecting the active video input signal.

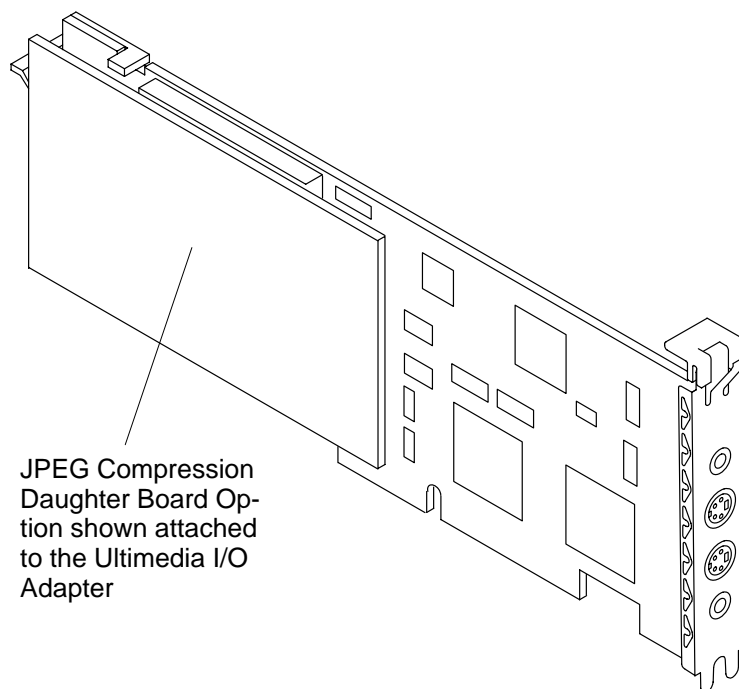

Ultimedia Video I/O Adapter Specifications

FRU numbers	Base Card, 88G3711 Guest Card, 88G3717
Bus architecture	Micro Channel
Maximum number	1
Connectors	Input 1 - RCA Jack-CVBS 1 - Mini Din S-Video Output 1 - RCA Jack-CVBS 1 - Mini Din S-Video
Cables	Supplied by Customer
Video Input Format	NTSC, PAL, S-Video
Mandatory Software	AIX/6000 Version 3.2.5 AIX Windows Environment/6000 Version 1.2.3 Ultimedia Service for AIX Version 1.2.1 or later or AIX/6000 Version 4.1 with AIXwindows 2D and SOMobject Base Tool Kit installed Ultimedia Services for AIX Version 2.1.1 or later

Ultimedia Video I/O Adapter Connector

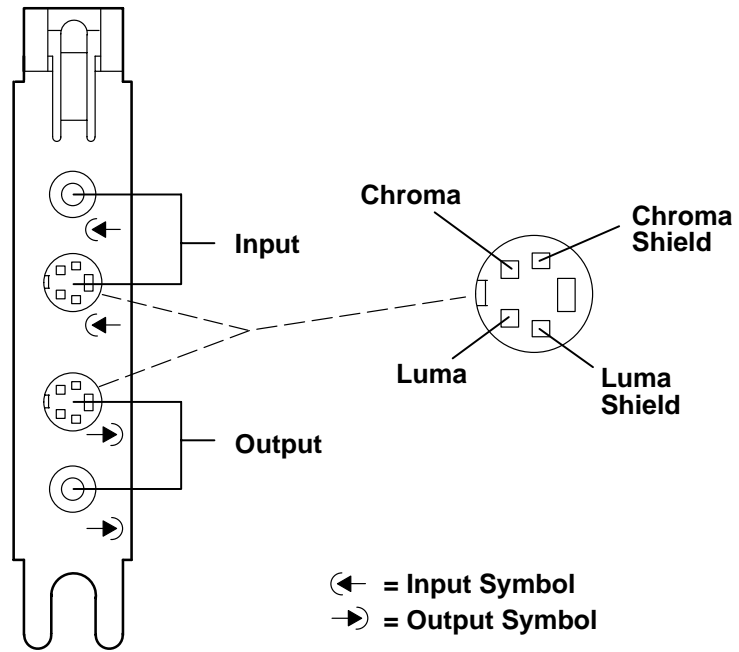

FC (6302) Ultimedia Audio Adapter (Type 7-6)

The Ultimedia Audio Adapter supports industry standard formats, it is designed to provide business audio solutions to applications enhancing customer productivity and communications.

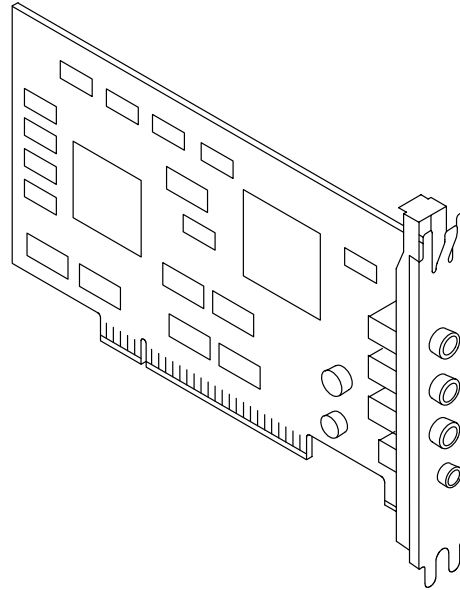

Ultimedia Audio Adapter Specifications

FRU number	88G2774
Bus architecture	Micro Channel
Maximum number	Two audio adapters may be installed on R10, R20, and R24 One audio adapter may be installed on all other system units.
Cable	Internal Audio connector cable for connection to CD ROMs on certain workstations (supplied with adapter)
Mandatory Software	Refer to the documentation provided with the adapter.

FC (2402) Network Terminal Accelerator 256 Adapter (Type 8-5)

The Network Terminator Accelerator 256 is a unique Ethernet interface adapter that offloads the host processor of TCP/IP, TELNET, and RLOGIN protocol processing. The adapter supports IEEE 802.3 and Ethernet version 2 protocols, and it acts as a standard Ethernet adapter, passing other protocol packets directly to the host for normal processing.

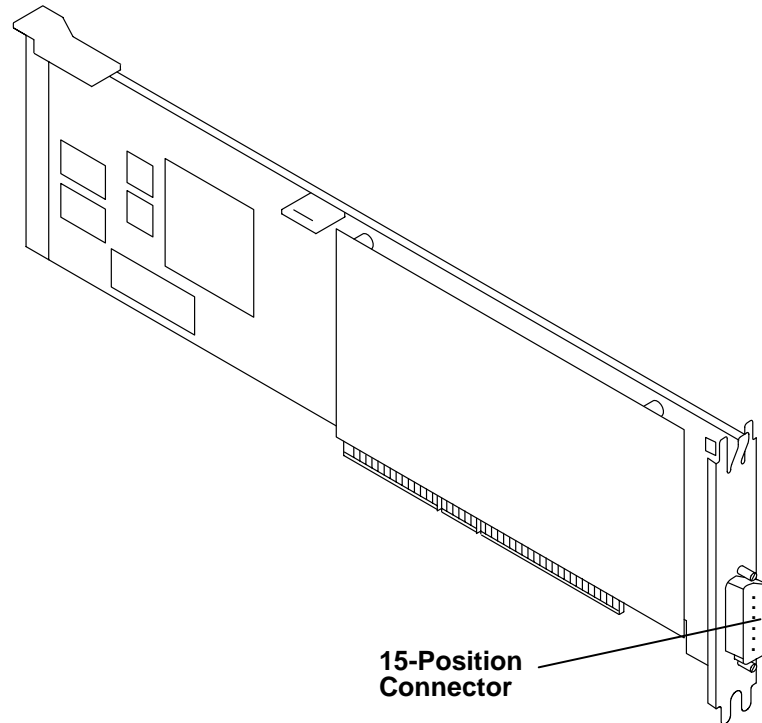

Network Terminal Accelerator 256 Adapter Specifications

FRU Number	51G8538
Position ID	0x9500
Bus architecture	Micro Channel
I/O Addresses	Assigned by program within range 400-4E000
Interrupt levels	4, 5, 6, 7, 9, 10, 11, 12
Busmaster	Yes
Maximum number	7
Connector	15-position D-shell
Adapter wrap plug	15-position D-shell, part number 70F9625
Transceivers	Thin, part number 02G7437 Twisted-pair, part number 02G7431
Transceiver cable	Adapter-to-transceiver, part number 02G7434

Network Terminal Accelerator 256 Adapter 15-Position Connector

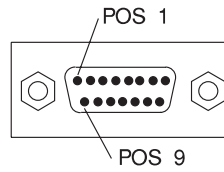

Position	Mnemonic	Signal Name
1	CI-S	Control in circuit-shield
2	CI-A	Control in circuit-A
3	DO-A	Data out circuit-A
4	DI-S	Data in circuit-shield
5	DI-A	Data In circuit-A
6	Vc	Voltage common
7	Unused	
8	Unused	
9	CI-B	Control in circuit-B
10	DO-B	Data out circuit-B
11	DO-S	Data out circuit-shield
12	DI-B	Data in circuit-B
13	VP	Voltage plus
14	VS	Voltage shield
15	Unused	
Shell	PG	Protective ground (conductive shell)

FC (2403) Network Terminal Accelerator 2048 Adapter (Type 8-6)

The Network Terminator Accelerator is a unique Ethernet interface adapter that offloads the host processor of TCP/IP, TELNET, and RLOGIN protocol processing. The adapter supports IEEE 802.3 and Ethernet version 2 protocols, and it acts as a standard Ethernet adapter, passing other protocol packets directly to the host for normal processing.

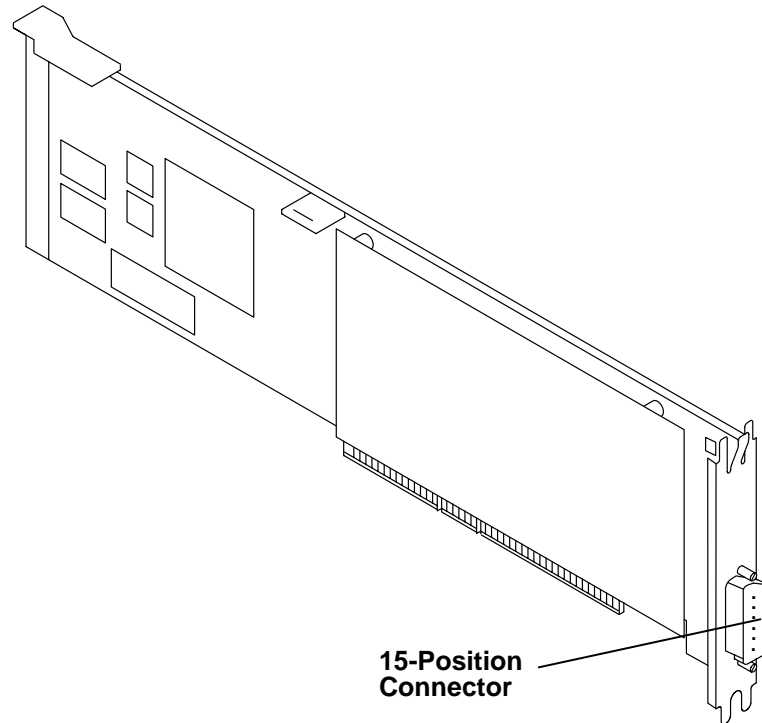

Network Terminal Accelerator 2048 Adapter Specifications

FRU Number	51G8539
Position ID	0x7200
Bus architecture	Micro Channel
I/O Addresses	Assigned by program within range 400-4E000
Interrupt levels	4, 5, 6, 7, 9, 10, 11, 12
Busmaster	Yes
Maximum number	7
Connector	15-position D-shell
Adapter wrap plug	15-position D-shell, part number 70F9625
Transceivers	Thin, part number 02G7437 Twisted-pair, part number 02G7431
Transceiver cable	Adapter-to-transceiver, part number 02G7434

Network Terminal Accelerator 2048 Adapter 15-Position Connector

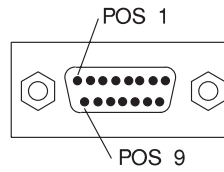

Position	Mnemonic	Signal Name
1	CI-S	Control in circuit-shield
2	CI-A	Control in circuit-A
3	DO-A	Data out circuit-A
4	DI-S	Data in circuit-shield
5	DI-A	Data In circuit-A
6	Vc	Voltage common
7	Unused	
8	Unused	
9	CI-B	Control in circuit-B
10	DO-B	Data out circuit-B
11	DO-S	Data out circuit-shield
12	DI-B	Data in circuit-B
13	VP	Voltage plus
14	VS	Voltage shield
15	Unused	
Shell	PG	Protective ground (conductive shell)

FC (2735) High-Performance Parallel Interface (HIPPI) Channel Attachment

Transmit Card (Type 8-A), Receive Card (Type 8-B)

The HIPPI adapter set consists of three cards. Interconnection is made by three controlled impedance flex circuit cables. The complete HIPPI subsystem requires five Micro Channel slots. The two additional slots are needed to meet Micro Channel requirements. One vacant card slot is required adjacent to the receive card to insure proper component clearance. In other words there are some tall components on the solder side of the receive card.

Note: Be sure to install adapters in the order illustrated. Be sure the ends of all connectors are latched behind the latch clips. Remove the three-position cables first when installing or removing cards. Be sure that all plugs and connectors align correctly.

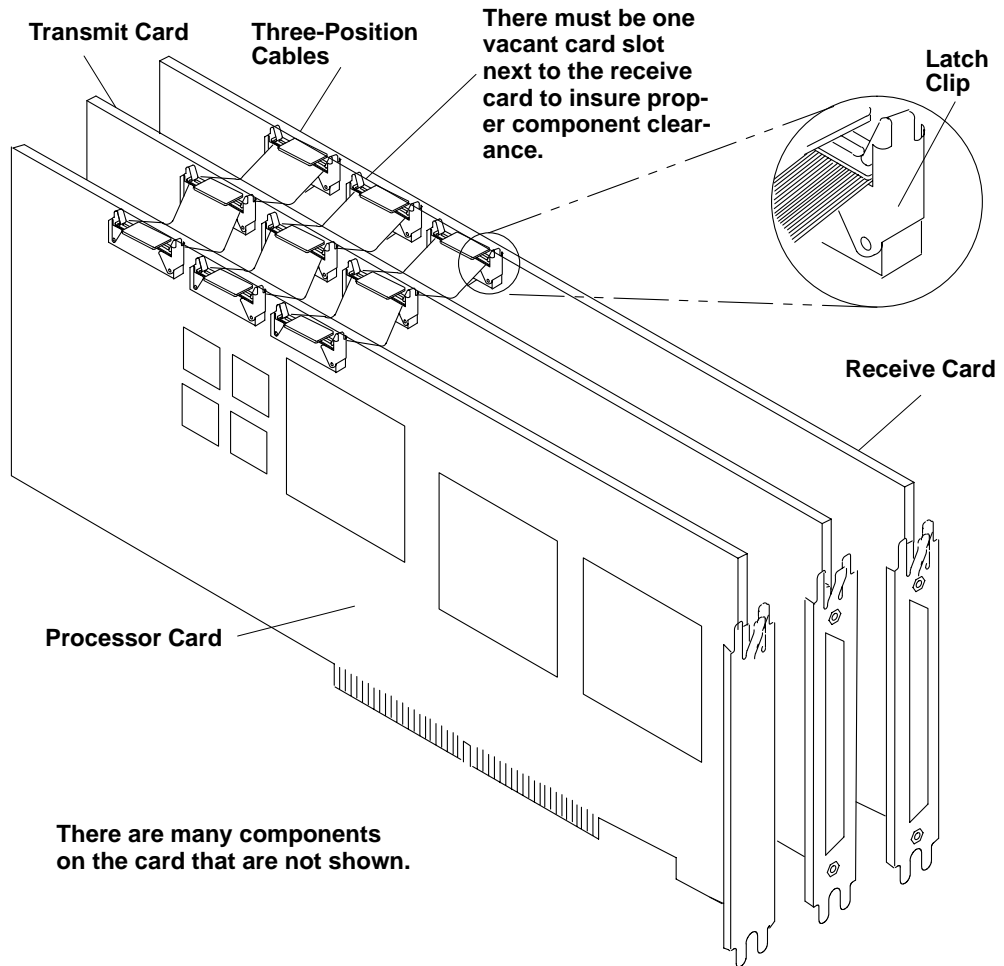

HIPPI Attachment Adapter Specifications

FRU Part Numbers	Processor card, 51G9994 Transmit card, 51G9996 Receive card, 11H2504 Crossover cable (three-position) 51G9226
I/O Bus Architecture	Micro Channel
Busmaster	Yes
Maximum number	64-bit wide data streaming 1 per Micro Channel
Microcode File Name	7015 Models 970B, 980B and 990 can have one on each Micro Channel 8fe5.00.nn (where nn is the revision level)
Sustained Data Transfer	up to 66MBps

HIPPI Attachment Adapter Cabling

The cables for this adapter are customer supplied. They must be HIPPI compliant with ANSI standard HIPPI-pH X3. 183-1991.

FC (2972) Auto Token-Ring LANstreamer MC 32 Adapter (Type 8-S)

This is a high performance token-ring adapter which is well suited for servers and high-end workstations running I/O intensive applications in a network environment.

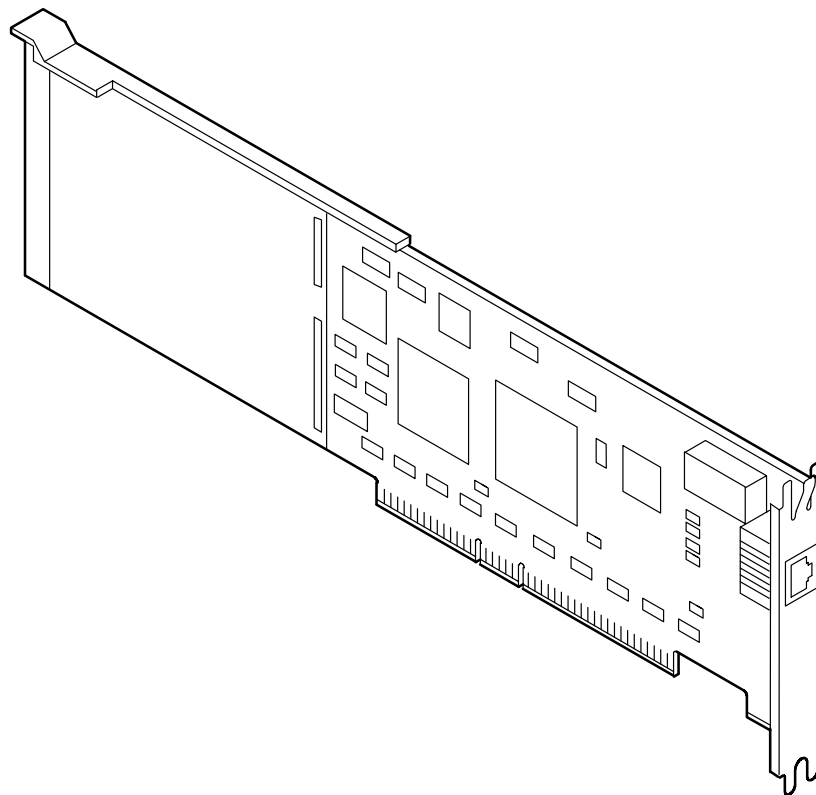

Auto Token-Ring LANstreamer MC 32 Adapter Specifications

FRU Number	60G1593
I/O addresses	0000 - fc00 in 0400 increments
Interrupt levels	2, 3, 10, 11
Bit rate	4Mb or 16Mb per second (can be set by autosense or configurator)
Bus architecture	Micro Channel
Busmaster	Yes
Maximum number	N/A
Connector	RJ-45
Cables	60G1066 .254 m (10 inch) included or 60G1063 3 m (10 ft) ordered through AAS

Auto Token-Ring LANstreamer MC 32 Adapter Connector

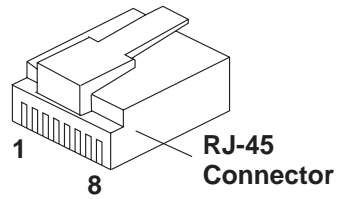

Position	Signal Name
1	No Connect
2	No Connect
3	Ring Out A
4	Ring In B
5	Ring In A
6	Ring Out B
7	No Connect
8	No Connect

FC (2992) High-Performance Ethernet LAN Adapter (8F95) AUI and 10BaseT (Type 8-U)

This adapter provides a way for the system units to attach to a carrier sense multiple access/collision detection (CSMA/CD) Ethernet network. This adapter attaches to either the IEEE-802.3 type network or the Ethernet version 2 network. The adapter has connectors for both (AUI) with external transceiver and 10BaseT (twisted pair) connections. Only one connector can be used at one time. The (AUI) allows connection to any Ethernet media with an appropriate transceiver. The 10BaseT port may be attached to a full duplex switch to enable full duplex operation.

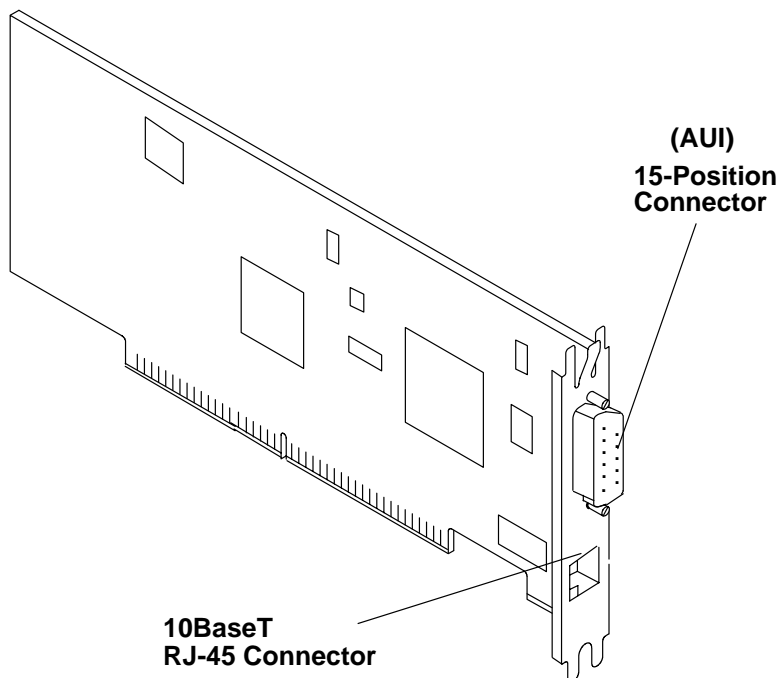

Ethernet High-Performance LAN Adapter Specifications

FRU Number	39H8817
Interrupt levels	3, 4, 5, 6, 7, 9, 10, 11
Bus architecture	Micro Channel
Busmaster	40 MB/sec
Maximum number	8 per Micro Channel
Connectors	8-position RJ-45 15-position D-shell
Adapter wrap plugs	15-position D-shell, part number 70F9625 RJ-45 (twisted-pair), part number 00G2380

Customer Supplied	Items
Cables	Customer supplied
Transceivers	10Base2 (Thin), part number 02G7437 10BaseT (Twisted-Pair), part number 02G7431
Transceiver cable	Adapter-to-transceiver Part number 02G7434
Transceiver wrap plugs	Thin, part number 02G7433 Twisted-Pair, part number 00G2380

Ethernet High-Performance LAN Adapter (8F95) 15-Position AUI Connector

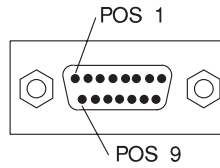

Position	Mnemonic	Signal Name
1	CI-S	Control in circuit-shield
2	CI-A	Control in circuit-A
3	DO-A	Data out circuit-A
4	DI-S	Data in circuit-shield
5	DI-A	Data In circuit-A
6	Vc	Voltage common
7	CO-A	Control out circuit-A
8	CO-S	Control out circuit-shield
9	CI-B	Control in circuit-B
10	DO-B	Data out circuit-B
11	DO-S	Data out circuit-shield
12	DI-B	Data in circuit-B
13	VP	Voltage plus
14	VS	Voltage shield
15	CO-B	Control out-B
Shell	PG	Protective ground (conductive shell)

Ethernet High-Performance LAN Adapter (8F95) 8-Position RJ-45 Twisted-Pair Connector

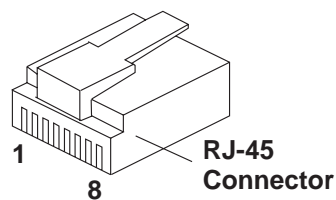

Position	Mnemonic	Signal Name
1	TD+	Upward Data + (positive for HI signal)
2	TD-	Upward Data - (negative for HI signal)
3	RD+	Downward Data + (positive for HI signal)
4	Reserved	Reserved
5	Reserved	Reserved
6	RD-	Downward Data - (negative for HI signal)
7	Reserved	Reserved
8	Reserved	Reserved

FC (2993) High-Performance Ethernet LAN Adapter (8F95) 10Base2 (Type 8-V)

This adapter provides a way for the system units to attach to a carrier sense multiple access/collision detection (CSMA/CD) Ethernet network. This adapter attaches to either the IEEE-802.3 type network or the Ethernet version 2 network. The adapter has a BNC connector for 10Base2 (thin coaxial) media connection.

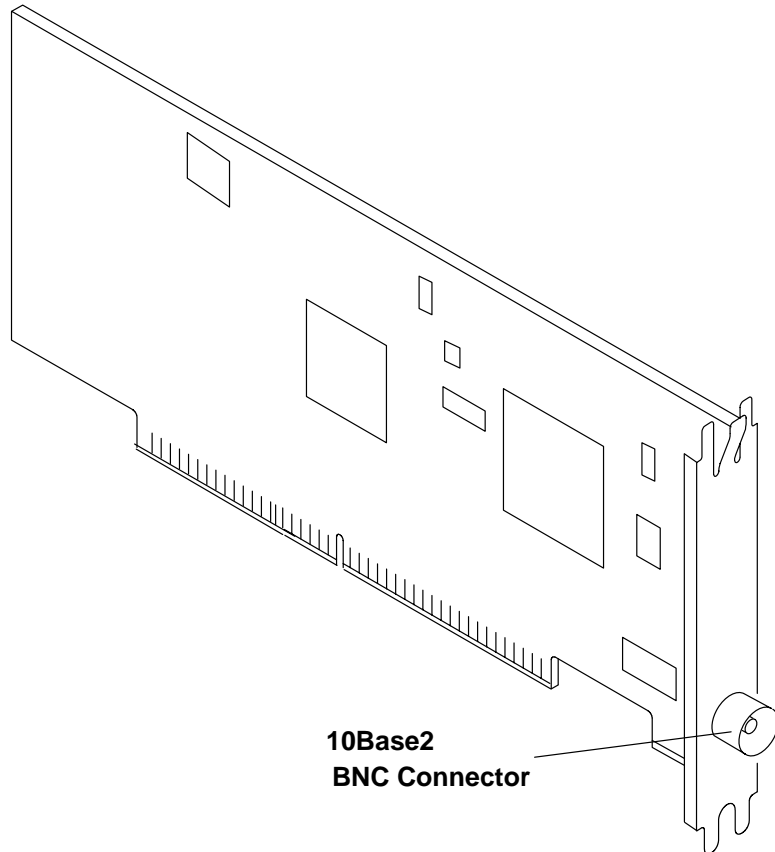

Ethernet LAN Adapter Specifications

FRU Number	39H8826
Interrupt levels	3, 4, 5, 6, 7, 9, 10, 11
Bus architecture	Micro Channel
Busmaster	40 MB/sec
Maximum number	8 per Micro Channel
Connectors	BNC coaxial
Adapter wrap plug	BNC, 25-ohm terminator, part number 70F9626

Customer Supplied	Items
Cables	Customer Supplied

FC (2984) TURBOWAYS 100 ATM Adapter (Type 8-W)

The TURBOWAYS 100 Asynchronous Transfer Mode (ATM) Adapter provides the interface between the ATM 100 Mbit/sec fiber-optics network and the Micro-Channel in your system.

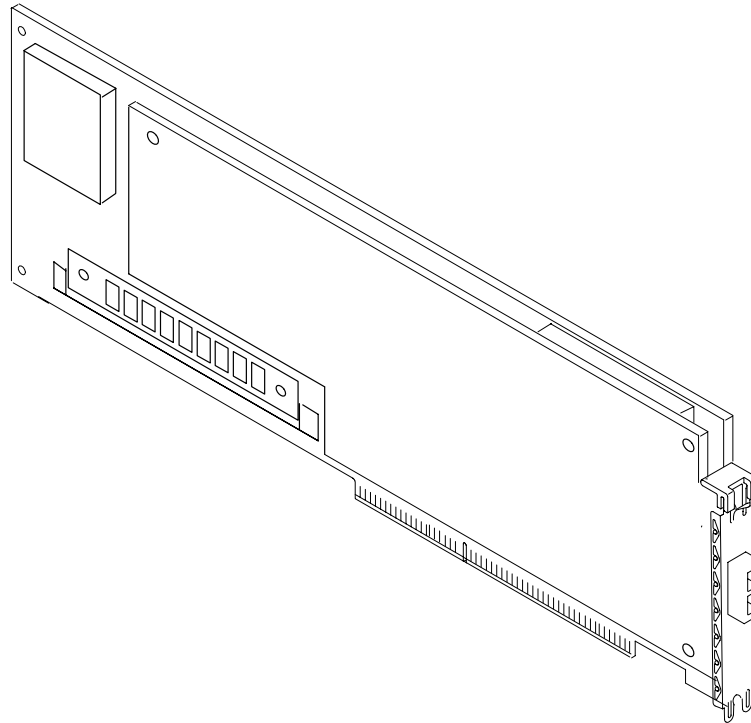

TURBOWAYS 100 ATM Adapter Specifications

FRU Number	73G9819
Bus architecture	Micro Channel
Maximum number	2 per system
Connector	ANSI Specified SC duplex
Jumper Cables	Fiber optic, customer provided
Microcode filename	/etc/microcode/00613300D.00. (Diagnostic) /etc/microcode/7F8FD.00.01
Microcode filename	/usr/lpp/DDFI.OUT (Functional)
Wrap Plug	16G5609 Shipped with assembly

FC (1906) Fibre Channel/266 Adapter (Type 8-X)

The Fibre Channel/266 Adapter provides the interfacing between a 266 Mbit/sec fiber-optics channel and the Micro-Channel in your system. It is designed for point-to-point communications between two systems or between one system and a switch (fabric).

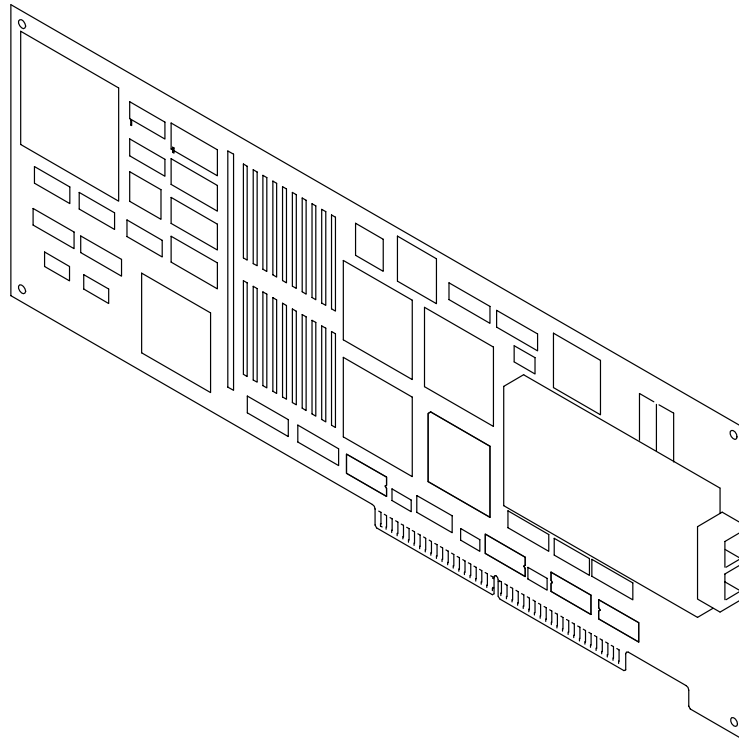

Fibre Channel/266 Adapter Specifications

FRU Number	52G1006
Bus architecture	Micro Channel
Maximum number	2 per system
Connector	ANSI Specified SC duplex
Jumper Cables	Fiber optic, customer provided Optical Link Products 1-800-426-6786
Microcode filename	8fe2d.00.00 (Diagnostic)
Microcode filename	8fe1.00.01 (Functional)
Wrap Plug	16G5609 Shipped with assembly
End-of-cable wrap plug	99F4916
OR	
Feed through Connector	19G4881 with half-meter fiber optic cable 99F4880

FC (2921, 2924, 2928) ARTIC960 4-Port Multiprotocol Communications Controller (Type 9-1)

This adapter provides a way to attach the system units to several types of communications networks. The adapter consists of the multiprotocol base card and the Application Interface Board (AIB). This combination provides four individually-addressable communications channels. See memory boards below.

The base card is available with three memory options. The last number of the three feature codes (FC) specifies the amount of memory in megabytes.

There are four AIBs. Each AIB has four ports which are all the same protocol. Each of the four ports can be attached to and operate with one network. The AIB protocols supported are X.21, V.36, EIA 530 and asynchronous EIA 232.

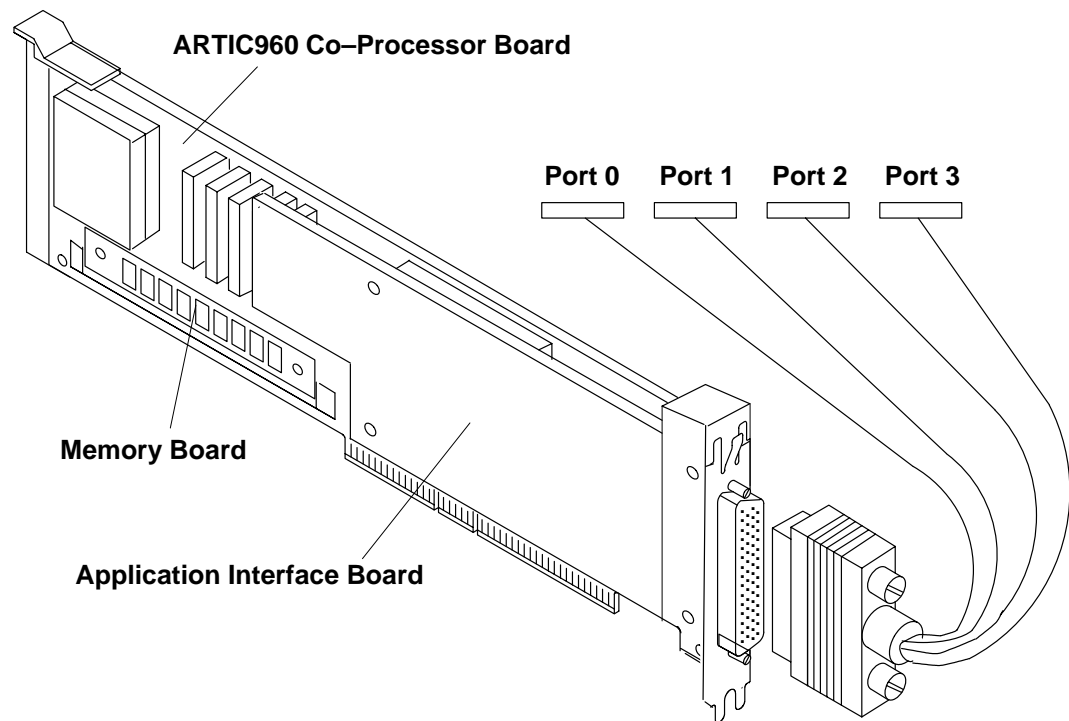

ARTIC960 4-Port Multiprotocol Communications Controller Specifications

FRU Numbers Base card, part number 61G2916
 Application Interface board, part number 61G2961 (order separately)
 1 MB Memory Board, part number 59F4581 (order separately)
 4 MB Memory Board, part number 70F9973 (order separately)
 8 MB Memory Board, part number 71G6450 (order separately)

Bus Architecture Micro Channel
 I/O addresses 02A0 - 1EA0
 Interrupt levels 3, 4, 7, 9, 10, 11, 12
 Busmaster Set to No at power on, set to Yes by program
 Maximum number 8
 Microcode file name /usr/lib/microcode/00100000d.00.01 (use for 3.2.5 releases)
 /usr/lib/microcode/00100000d.00.010/1RC8fd.00.01

Connector 100-position, D-shell
 Wrap plugs 100-position, FRU number 53G0632
 EIA-232D, FRU number 33F8985
 EIA-530 (RS-422), FRU number 53G0639
 ISO 4902 V.36 (V.35 compatible), FRU number 53G0641
 ISO 4903 (X.21), FRU/part number 53G0638

Cables See below

Feature Code	Cable Name/Description	FRU Number	Length	
			m	ft
2922	Cable Option EIA 232D	61G2919	1.8	6
2923	Cable Option EIA 530 (RS-422)	61G2924	1.8	6
2926	Cable Option ISO 4902 (V.36)	61G2934	1.8	6
2927	Cable Option ISO 4903 (X.21)	61G2929	1.8	6

ARTIC960 4-Port EIA-232D AIB 100-Position and 25-Position Connectors

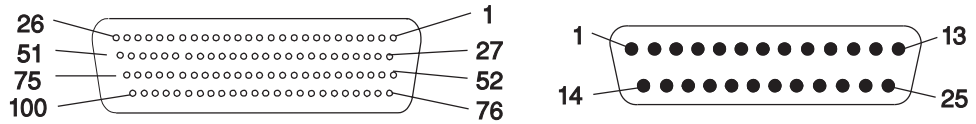

Signal Name or Mnemonic	I/O	Port 0	Port 1	Port 2	Port 3	25-Position Connector
TxD	O	05	12	18	24	02
RxD		80	86	92	99	03
RTS	O	31	37	68	74	04
CTS		32	39	45	51	05
DCD		81	62	94	100	08
DTR	O	07	13	19	26	20
DSR		57	63	69	50	06
SGND	--	06	38	44	25	07
Shield GND		--	Housing	Shield		01/Housing

ARTIC960 4-Port EIA-530/RS-422 AIB 100-Position and 25-Position Connectors

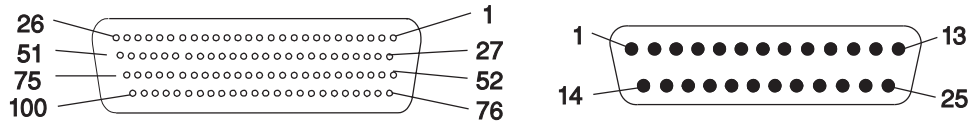

Signal Name or Mnemonic	I/O	Port 0	Port 1	Port 2	Port 3	25-Position Connector
TXDxA	O	01	09	15	21	02
TXDxB	O	27	34	41	47	14
RTSxA	O	03	11	17	23	04
RTSxB	O	29	36	43	49	19
RXDxA		52	58	64	95	03
RXDxB		76	82	88	70	16
CTSxA		30	61	67	98	05
CTSxB		04	85	91	73	13
CDxA		55	33	40	20	08
CDxB		79	08	14	46	10
RCLKIxA		54	60	66	97	17
RCLKIxB		78	84	90	72	09
TCLKOxA	O	02	10	16	22	24
TCLKOxB	O	28	35	42	48	11
TCLKIxA		53	59	65	96	15
TCLKIxB		77	83	89	71	12
SGND	--	06	38	44	25	07
ShieldGND	-- Housing Shield					01/Housing

ARTIC960 4-Port ISO-4902 (V.36) AIB 100-Position and 37-Position Connectors

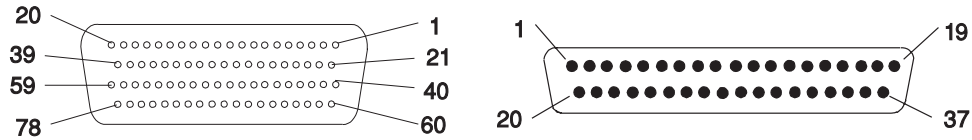

Signal Name or Mnemonic	I/O	Port 0	Port 1	Port 2	Port 3	37-Position Connector
TXDxA	O	01	09	15	21	04
TXDxB	O	27	34	41	47	22
RTSx	O	31	37	68	74	25
RXDxA		52	58	64	95	06
RXDxB		76	82	88	70	24
CTSx		32	39	45	51	27
DSRx		57	63	69	50	29
DTRx	O	07	13	19	26	30
CDx		81	62	94	100	31
RCLKIxA		54	60	66	97	08
RCLKIxB		78	84	90	72	26
TCLKOxA	O	02	10	16	22	17
TCLKOxB	O	28	35	42	48	35
TCLKIxA		53	59	65	96	05
TCLKIxB		77	83	89	71	23
SGND	--	06	38	44	25	19, 20, 37
ShieldGND	-- Housing					01/Housing

ARTIC960 4-Port ISO 4903 (X.21) AIB 100-Position and 15-Position Connectors

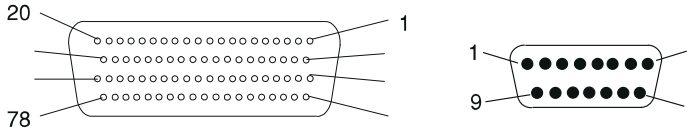

FC (2938) ARTIC960 (4M) 8-Port X.21 Communications Controller (Type 9-2)

This adapter provides a way to attach the system units to several types of communications networks. The adapter consists of the multiprotocol base card and the Application Interface Board (AIB). This combination provides eight individually-addressable communications channels. The base card has four megabytes of memory.

The AIB supports up to eight ports of X.21 protocol. Each of the eight ports can be attached to and operate one network.

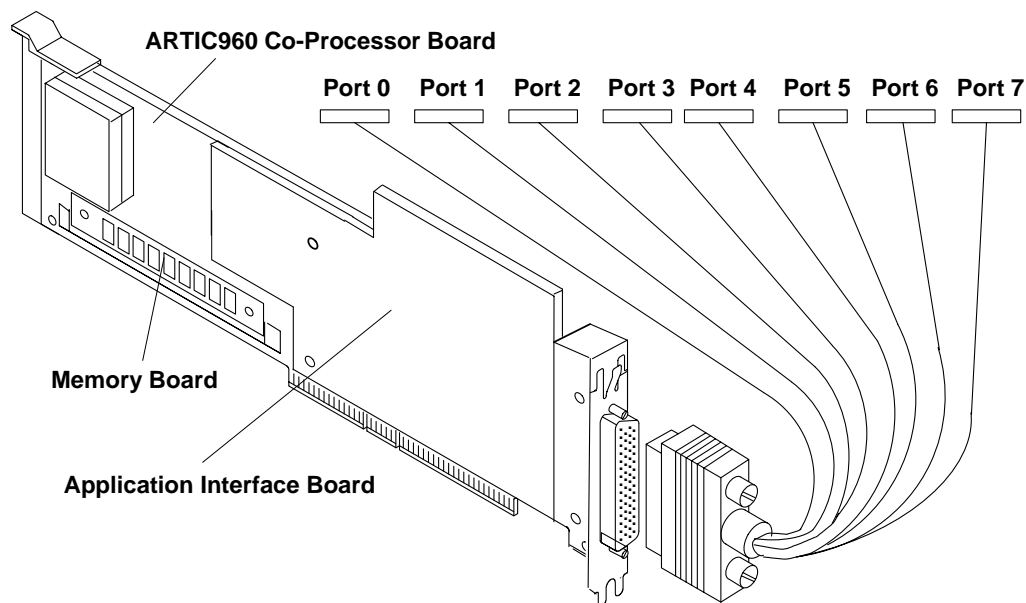

ARTIC960 (4M) 8-Port X.21 Communications Controller Specifications

FRU Numbers	Base card, part number 61G2916 Application Interface board, part number 06H2141 (order separately) 4 MB Memory Board, part number 70F9973 (order separately)
Bus architecture	Micro Channel
I/O addresses	02A0 - 1EA0
Interrupt levels	3, 4, 7, 9, 10, 11, 12
Busmaster	Set to No at power on, set to Yes by program
Microcode file name	/usr/lib/microcode/00200000d.00.01 (use for 3.2.5 releases) /usr/lib/microcode/00200000d.00.010/1RC8fd.00.01
Connector	100-position, D-shell
Wrap plug	ISO 4903 (X.21), FRU/part number 06H3357 X.21 cable, FRU/part number 52G3378

Feature Code	Cable Name/Description	FRU Number	Length	
			m	ft
2922	Cable Option ISO 4903 (X.21)	06H4648	1.8	6

ARTIC960 (4M) 8-Port ISO 4903 (X.21) AIB 100-Position and 15-Position Connectors

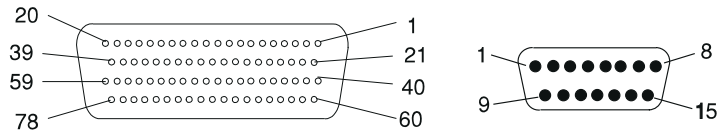

Mnemonic	I/O	Port 0	Port 1	Port 2	Port 3	Port 4	Port 5	Port 6	Port 7	15-Position Connector
TXDxA	O	01	04	08	11	14	17	21	24	02
RXDxB	O	27	30	33	66	40	43	46	49	09
CTLxA	O	02	05	09	12	15	18	22	50	03
CTLxB	O	28	31	34	37	41	19	47	75	10
RXDxA		52	55	58	61	64	67	70	73	04
RXDxB		76	79	82	85	88	91	94	97	11
INDxA		53	56	59	62	65	68	71	74	05
INDxB		77	80	83	86	89	92	95	98	12
RCLKxA		54	57	60	63	66	69	72	99	06
RCLKxB	O	78	81	84	87	90	93	96	100	13
TCLKxA	O	03	07	10	13	16	20	23	26	07
TCLKxB		29	32	35	39	42	45	48	51	14
SGND	--	06		25		38		44		08
ShieldGND	Cable Shield									01

FC (2929) ARTIC960 (4M) 8-Port EIA-232 E Communications Controller (Type 9-3)

This adapter provides a way to attach the system units to EIA-232 E communications networks. The adapter consists of the multiprotocol base card and the Application Interface Board (AIB). This combination provides eight individually-addressable communications channels. The base card is available with four megabytes of memory.

The AIB supports up to eight EIA-232 E ports at speeds up to 28K bits per second.

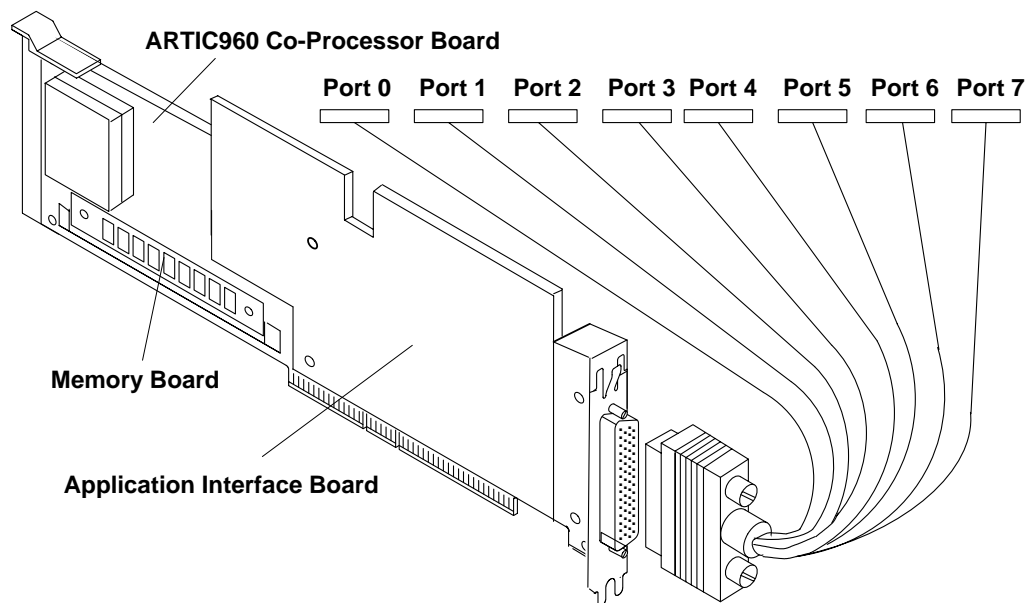

ARTIC960 8-Port EIA-232 E Communications Controller Specifications

FRU Numbers	Base card, part number 61G2916 Application Interface board, part number 11H3786 (order separately) 4 MB Memory Board, part number 70X9973 (order separately)
Bus architecture	Micro Channel
I/O addresses	02A0 - 1EA0
Interrupt levels	3, 4, 7, 9, 10, 11, 12
Busmaster	Set to No at power on, set to Yes by program
Maximum number	8
Microcode file name	/usr/lib/microcode/00300000d.00.01 (use for 3.2.5 releases) /usr/lib/microcode/00300000d.00.010/1RC8fd.00.01
Connector	100-position, D-shell
wrap plugs	100-position, FRU number 68F7208 EIA-232 E, FRU number 33F8985

Feature Code	Cable Name/Description	FRU Number	Length	
			m	ft
2939	Cable Option EIA-232 E	71G3497	1.8	6

ARTIC960 8-Port EIA-232 E Communications Controller 100-Position and 25-Position Connectors

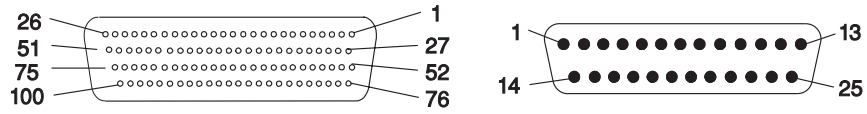

Mnemonic	I/O	Port 0	Port 1	Port 2	Port 3	Port 4	Port 5	Port 6	Port 7	25-Position Connector
TxD	O	51	54	07	10	13	16	94	48	02/BA
RxD		02	05	83	86	89	92	46	74	03/BB
RTS	O	01	04	82	85	88	91	45	73	04/CA
CTS		77	80	34	37	40	43	71	24	05/CB
DCD		28	31	59	62	65	68	21	99	08/CF
DTR	O	76	79	33	36	39	42	70	23	20/CD
DSR		53	56	09	12	15	18	96	50	06/CC
HRS		27	30	58	61	64	67	20	98	23/CI
RI		03	06	84	87	90	93	47	75	22/CE
TxCLKIN		29	32	60	63	66	69	22	100	15/DB
TxCLK	O	52	55	08	11	14	17	95	49	24/DA
RxCLK		78	81	35	38	41	44	72	25	17/DD
SGND	--	19	19	26	26	57	57	97	97	07/AB
FGND	Cable Shield									01/AA

FC (2935) ARTIC960 (4M) 6-Port V.36 Communications Controller (Type 9-4)

This adapter provides a way to attach the system units to six V.36 communications networks. The adapter consists of the multiprotocol base card and a six port V.36 Application Interface Board (AIB). This combination provides six individually-addressable communications channels.

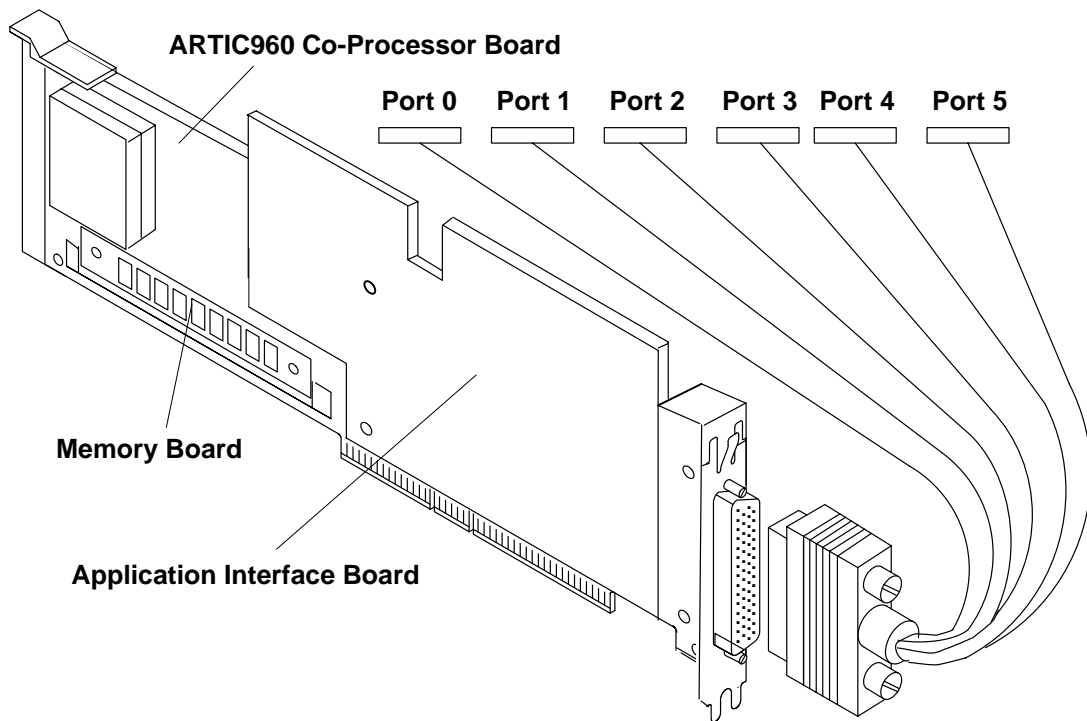

ARTIC960 6-Port V.36 Communications Controller Specifications

FRU Numbers	Base card, part number 61G2916 Application Interface board, part number 11H3795 (order separately) 4MB Memory Board, part number 70F9973 (order separately)
Bus Architecture	Micro Channel
I/O addresses	02A0 - 1EA0
Interrupt levels	3, 4, 7, 9, 10, 11, 12
Busmaster	Set to No at power on, set to Yes by program
Maximum number	8
Microcode file name	/usr/lib/microcode/00400000d.00.01 (use for 3.2.5 releases) /usr/lib/microcode/00400000d.00.010/1RC8fd.00.01
Connector	100-position, D-shell
Wrap plugs	100-position, FRU number 72F0168 ISO 4902 V.36 (V.35 compatible), FRU number 73H2508

Feature Code	Cable Name/Description	FRU Number	Length	
			m	ft
2941	Cable Option ISO 4902 (V.36)	11H3796	3	10

ARTIC960 6-Port ISO-4902 (V.36) AIB 100-Position and 37-Position Connectors



Mnemonic

FC (2989) TURBOWAYS 155 ATM Adapter (Type 9-9)

The TURBOWAYS 155 Asynchronous Transfer Mode (ATM) Adapter provides the interface between the ATM 155 Mbit/sec fiber-optics network and the Micro Channel in your system.

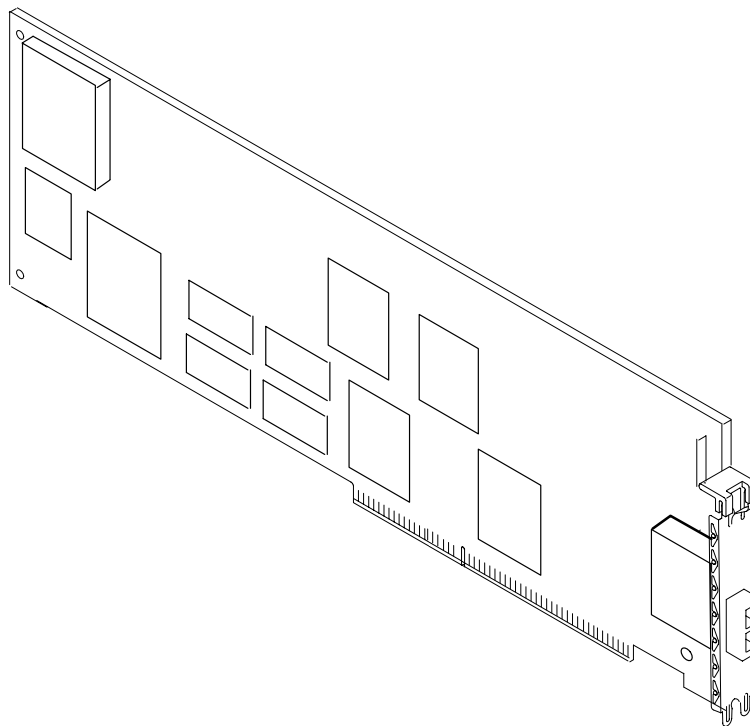

TURBOWAYS 155 ATM Adapter Specifications

FRU Number	34H6403
Bus architecture	Micro Channel
Busmaster	80 MB/sec
Card Type	Type 5 (single slot)
Maximum number	2 per Micro Channel
Connector	ANSI Specified SC duplex
Wrap Plug	16G5609 Shipped with assembly
Cables	62.5 micron multi-mode Fiber-optic, customer provided

FC (1904/1902) Fibre Channel 1063 Adapter Short Wave (Type 9-A)

The Fibre Channel 1063 Adapter provides the interfacing between a 1063 mega-bits/sec fibre-optic channel and the Micro Channel in your system. It is designed for point-to-point communications between two systems or between one system and a switch (fabric).

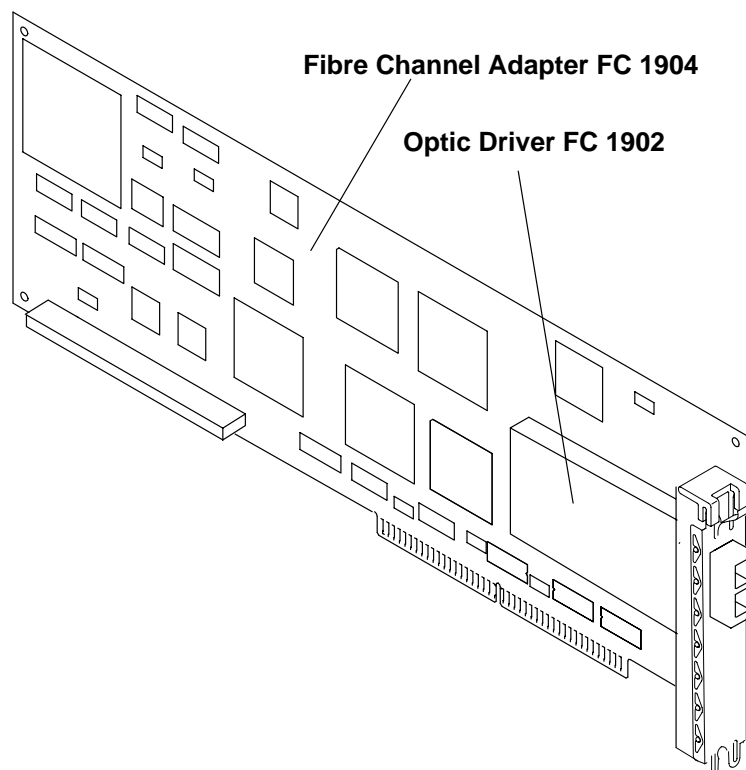

Fibre Channel 1063 (Short Wave) Adapter Specifications

FRU Number Adapter	73H2503
FRU Number Optic	65G5292
Card Type	Type 5
Bus architecture	Micro Channel
Microcode filename	8fe2d.00.00 (Diagnostic)
Microcode filename	8fe2.00.01 (Functional)
Connector	ANSI Specified SC duplex
Cable Type	50 micron multi-mode
Cables	Fibre-optic, customer provided
Wrap Plug	16G5609 Shipped with assembly
End-of-cable wrap plug	99F4916
OR	
Feed through Connector	19G4881 with half-meter fibre-optic cable 99F4880

FCS Cables

FCS Cables 50 Micron Multi-Mode

- 54G3384/54G3385 7 Meters
- 54G3384/54G3386 13 Meters
- 54G3384/54G3387 22 Meters
- 54G3384/54G3388 31 Meters
- 54G3384/54G3389 46 Meters
- 54G3384/54G3390 61 Meters
- 54G3384/54G3391 Custom Length Meters

Note: There are two part numbers shown in the table. The first is for ordering cables in the United States and the second is for ordering cables in other countries. Orders for cables can be placed through MES.

FC (2999) 155 ATM Video Streaming Adapter (Type 9-E)

The 155 Asynchronous Transfer Mode (ATM) Video Streaming Adapter is a Micro Channel adapter that provides 155 Mbps SONET OC-3 (single mode) fiber connectivity. In addition, the 155 ATM Video Streaming Adapter provides MPEG-2 PCR transmit pacing function.

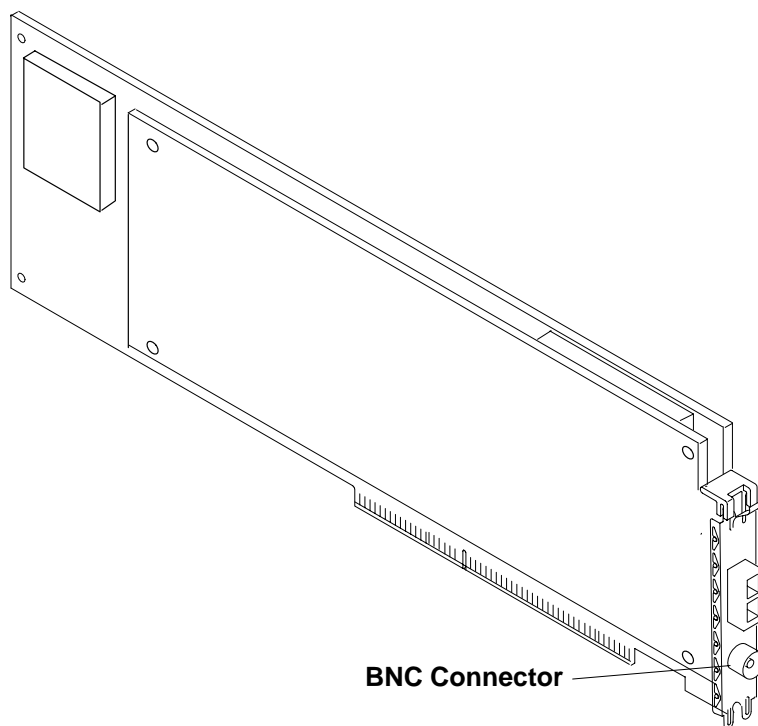

155 ATM Video Streaming Adapter Specifications

FRU Number	73H1685
Bus architecture	Micro Channel
Maximum number	The 155 ATM Video Streaming Adapter requires two Micro Channel slots due to power requirements. When the model 39H is used as the base system for the 155 ATM Video Streaming Adapter one can be installed. The adapter can be installed in any slot. And, one of the other slots must be left open or not used. When the model R20 is used as the base system for the 155 ATM Video Streaming adapter, up to two can be installed. When one Video Streaming Adapter is installed, it must be installed in slot one (1). And slot three must be left open or unused. When two Video Streaming Adapters are installed, they must be installed in slots one and two. Then slots three and four must be left open.
Connectors	ANSI Specified SC duplex 75 ohm BNC
Jumper Cables	Fiber optic, customer provided
Microcode filename	/etc/microcode/20115500d.00.01 (Diagnostic) /etc/microcode/8f66ddif.01 (functional)
Wrap Plug	82G3185 Shipped with assembly

FC (2994) 10/100 Mbps Ethernet MC Adapter (Type 9-K)

This adapter provides connectivity to 10/100 Base Ethernet LANs for RS/6000 systems that support the Micro Channel bus architecture. This adapter attaches to either 10 M/bps or 100 M/bps ethernet network via 10BaseT or 100BaseTX through an 8 pin RJ45 connector. The adapter is fully 802.3u fast ethernet standard compatible, with an ability to autonegotiate the speed and half/full duplex when connected to an autonegotiable switch. Category 3, 4 or 5 unshielded twisted-pair cable is required for 10 Mbps operation, and category 5 unshielded twisted-pair cable is required for 100 Mbps on the network.

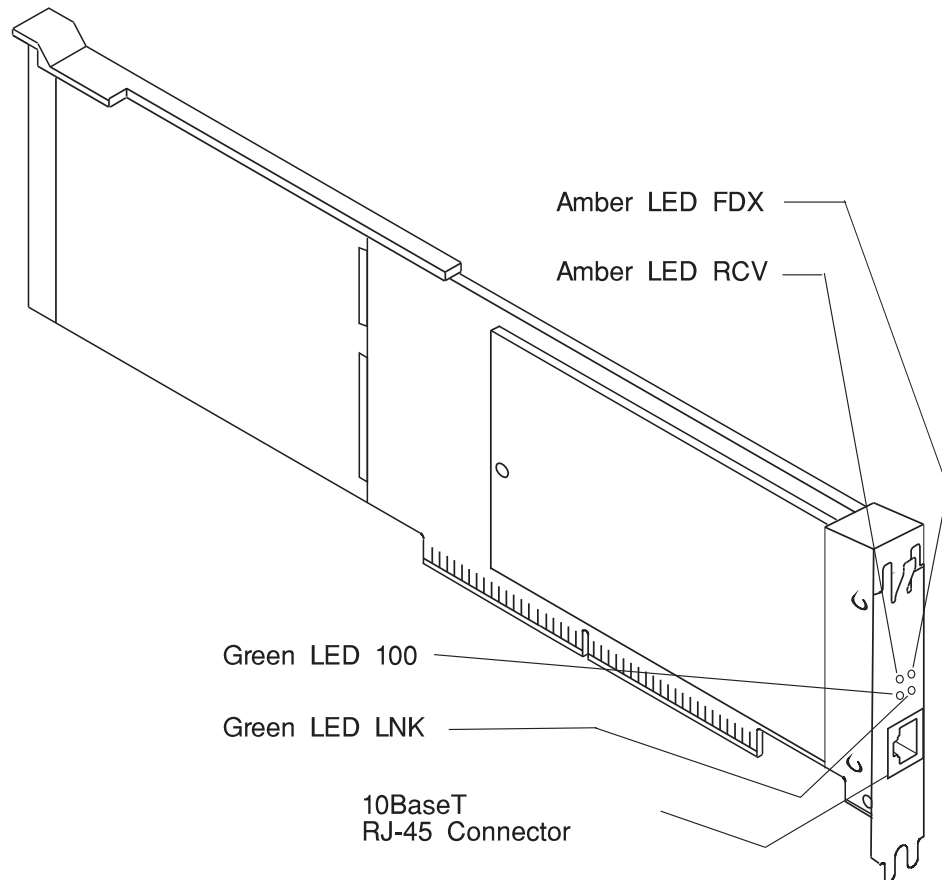

10/100 Mbps Ethernet MC Adapter Specifications

FRU Number	07L6601
Interrupt levels	10, 11, 12, 15
Bus architecture	Micro Channel
Form Factor	Type 3
Busmaster	80 MB/sec data streaming
Maximum number	1, 2 or 4 depending on the model number
Connector	8-position RJ-45
Adapter wrap plug	RJ-45 (twisted-pair), part number 00G2380

Customer Supplied	Items
Cables	Customer supplied

10/100 Mbps Ethernet MC Adapter 8-Position RJ-45 Twisted-Pair Connector

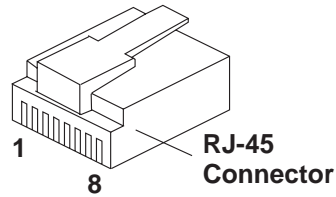

Position	Mnemonic	Signal Name
1	TD+	Upward Data + (positive for HI signal)
2	TD-	Upward Data - (negative for HI signal)
3	RD+	Downward Data + (positive for HI signal)
4	Reserved	Reserved
5	Reserved	Reserved
6	RD-	Downward Data - (negative for HI signal)
7	Reserved	Reserved
8	Reserved	Reserved

FC (8243) Media Streamer Audio/Video Decoder (Type *)

Note: * This adapter does not have an assigned type number.

The MPEG to analog video decoder adapter is an ISA form factor card. It decodes a stream of digital MPEG data, and outputs analog video and stereo audio. The output signal may be either in NTSC or PAL standard format. The MPEG data, reaches the card via a SCSI-2 cable.

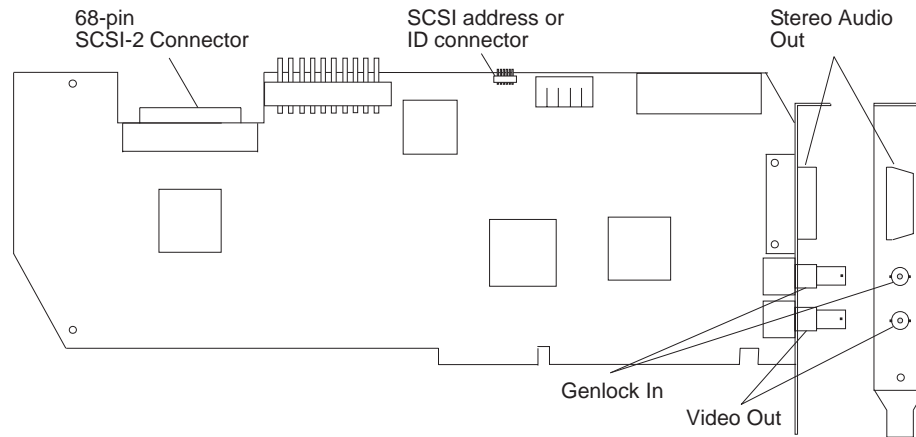

- **Connectors**

1. 68-pin SCSI-2 connector for control and data input
2. SCSI address (ID) connector, for attachment of a cable which takes the place of SCSI address jumpers.
3. Stereo audio out
4. Genloc in
5. Video out

Media Streamer Audio/Video Decoder Specifications

FRU Number	93H2136
Bus architecture	ISA
Bus description	The card requires a single ISA slot. It uses power only from the bus. Typically, these cards are in a special ADAC drawer, which has 14 slots for these adapters.

Media Streamer Audio/Video Decoder 15-pin D-Shell Audio Connector

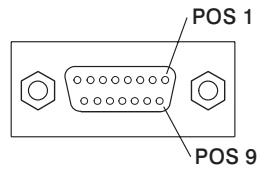

Position	Signal Name
1	right audio +
2	right audio -
3	shield
4	left audio -
5	left audio +
6	reserved
7	reserved
8	video start trigger
9	reserved
10	reserved
11	reserved
12	reserved
13	reserved
14	reserved
15	reserved

FC (2734) Keyboard and Mouse Adapter for 7013 Models J30 and J40 (Type *)

Note: * This adapter does not have an assigned Card Type.

This special adapter is used only on 7013 models J30 and J40. It provides a way to attach a keyboard and mouse to the system units.

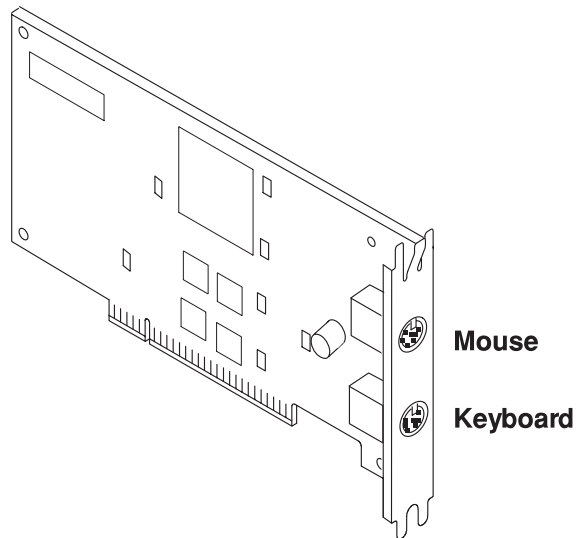

Keyboard and Mouse Adapter Specifications

FRU Number	40H7496
Bus architecture	Micro Channel
Adapter size	Type 3
Busmaster	No
Maximum number	1
Connector	2 - 6 position Mini Din
Cables	Come standard on the keyboard and mouse

Keyboard and Mouse Adapter 6-Position Mini Din Connector

The physical layout of the keyboard and mouse connector is shown in the following illustration.

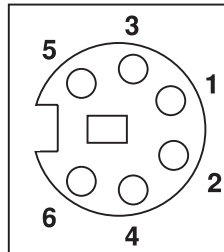

Keyboard Connector

Pin	Signal
1	Keyboard Data
2	Speaker Signal
3	Ground
4	+5V dc
5	Keyboard Clock
6	Speaker Ground

Mouse Connector

Pin	Signal
1	Mouse Data
2	Reserved
3	Ground
4	+5V dc
5	Mouse Clock
6	Reserved

Chapter 2. Devices Information

This chapter contains service data for the devices installed within system units. The specific information about these devices is included here to aid service personnel. This book is updated for most versions of the diagnostic programs.

Description of the Device Information

System unit manuals show only information that applies to all devices of a type. For example, the removal and replacement procedures in the service guide for a system unit show how to remove and replace *any* type of disk drive. This book shows the specific address switch settings for *each* type of disk drive.

How to Use the Device Information

The information about internally installed devices is used in nondirected service activities. The information in this chapter is used to:

- Identify a device.
- Find service information about a device.
- Where applicable, show the settings for address switches or jumpers.
- Provide a manual removal procedure for the CD-ROM caddy, compact disk, 4-mm, and 8-mm tape cartridges.
- Provide removal and replacement instructions for the electronic boards on the disk drives.

5.25-Inch Diskette Drive

The 5.25-inch diskette drive provides a way to read and write 5.25-inch diskettes. This drive can read or write on the 1.2M-byte diskette or it can read the 360K-byte diskette.

The 5.25-inch diskette drive is attached to the same built-in diskette drive adapter on the standard I/O planar that the 3.5-inch diskette drive uses.

Since the 5.25-inch diskette drive and the PS/2 5.25-inch external diskette drive both use the same internal cable connector, only one can be present on a system unit.

Setting the Terminator Resistor

The terminator resistor *must not* be installed on the internal 5.25-inch diskette drive when it is installed in the front panel of a system unit.

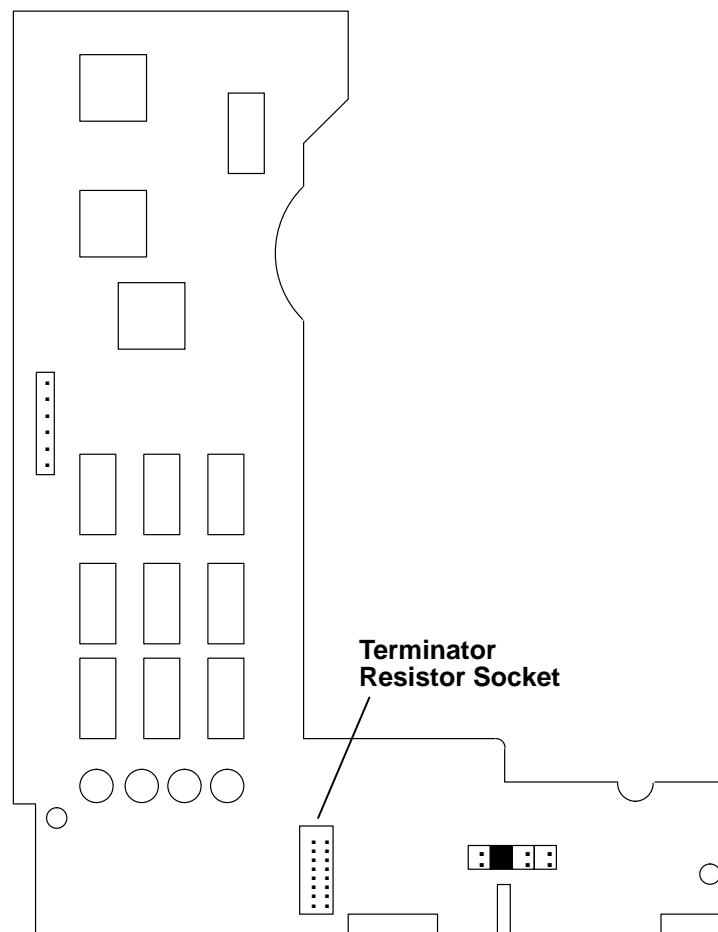

CD-ROM Drives

The CD-ROM drive is a read-only device which reads compact optical discs. The compact disc (CD) is removable. See "Laser Safety Information" on page xvii for the laser safety statement.

The CD-ROM drive connects to the internal SCSI bus cable coming from the standard SCSI I/O controller.

There are three types of CD-ROM drives. These are designated as type A, B and C. The three types of CD-ROM drives can be identified by looking at the front bezel as shown below. Type A and B CD-ROM drives need to have a disc caddy to insert the CD. Type C drives do not use a disc caddy, and simply insert the disc into a tray.

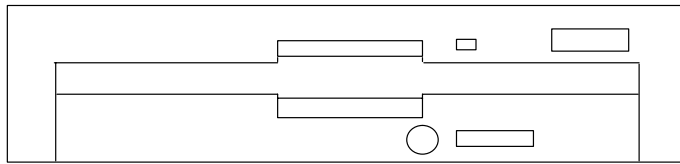

Type A Drive Bezel

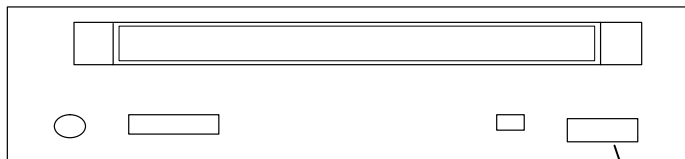

Type B Drive Bezel
(CD-ROM and CD-ROM-2 versions)
CD-ROM-2 Type B Drives have a white
underside on their unload buttons

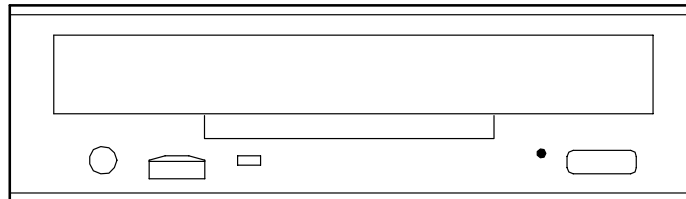

Type C Drive Bezel
(Double speed, Quad speed and 8X speed versions)

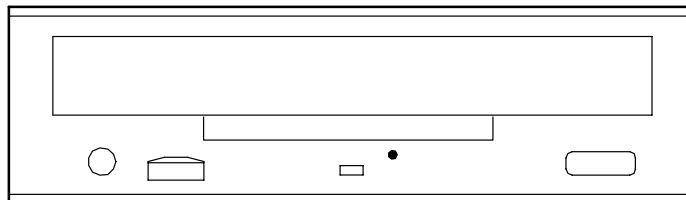

Type D Drive Bezel
(12 to 20X speed version)

Setting SCSI Addresses

Depending on the model or type of CD-ROM drive, the SCSI address is set with switches (Type A) or jumpers (Type B and Type C) located on the rear of the drive.

Type A Drive Switch Settings

Use the following table and diagram to locate and set SCSI address switches 1, 2, and 3 on Type A drives.

Note: Switches 4 and 5 should always be set to On and switch 6 set to Off as shown.

Address	Switch 1	Switch 2	Switch 3
0	Off	Off	Off
1	On	Off	Off
2	Off	On	Off
3	On	On	Off
4	Off	Off	On
5	On	Off	On
6	Off	On	On

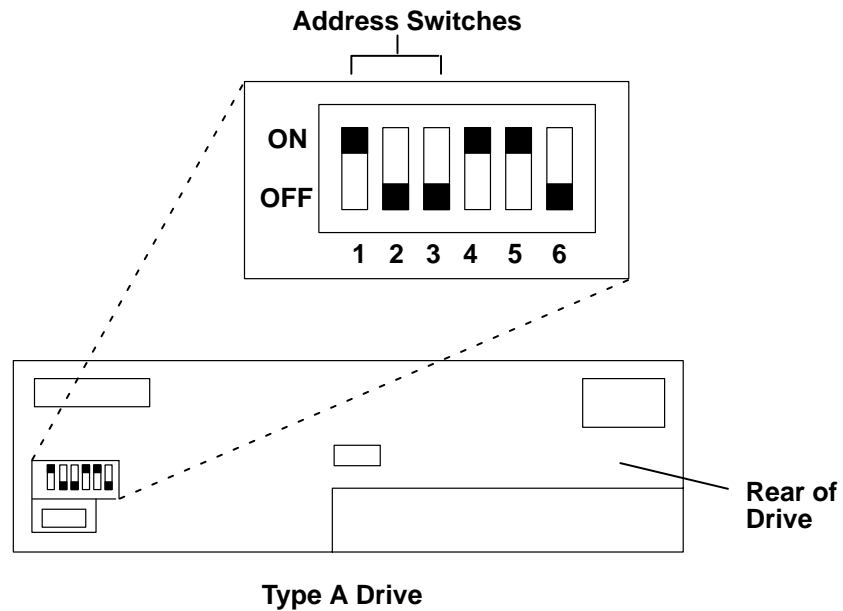

Type B Drive Jumper Settings

Use the following table and diagram to locate and set address jumpers on Type B CD-ROM drives. This includes both the CD-ROM and CD-ROM-2 versions. The jumper at position 6 should always be installed to allow media insertion and removal.

Note: CD-ROM-2 type B drives have an unload button which has a white underside.

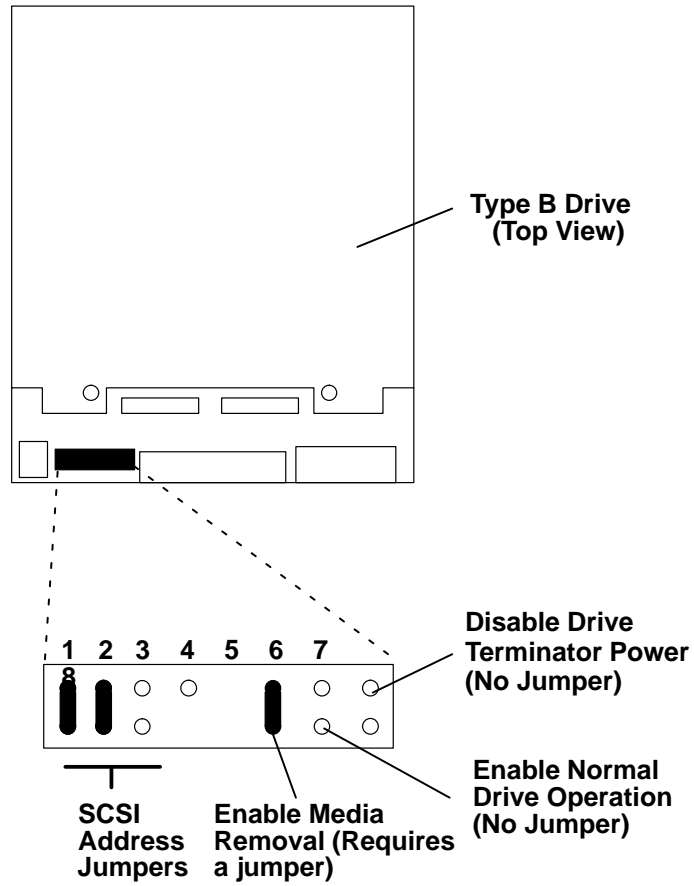

The jumpers are set at address 3 in diagram.

Address	Jumper 1	Jumper 2	Jumper 3
0	Off	Off	Off
1	On	Off	Off
2	Off	On	Off
3	On	On	Off
4	Off	Off	On
5	On	Off	On
6	Off	On	On

Type C Drive Jumper Settings

Use the following table and diagram to locate and set address jumpers on type C CD-ROM drives. There are three speeds of type C CD-ROM drives. There is a double-speed, quad-speed and 8X speed version. The bezel on all of the drives looks the same. However, the tray in the double-speed CD-ROM drive is white with two tabs, the tray in the quad-speed CD-ROM drive is white with four tabs, while the tray in the 8X CD-ROM drive is black with four tabs. Refer to the illustration on page 2-10.

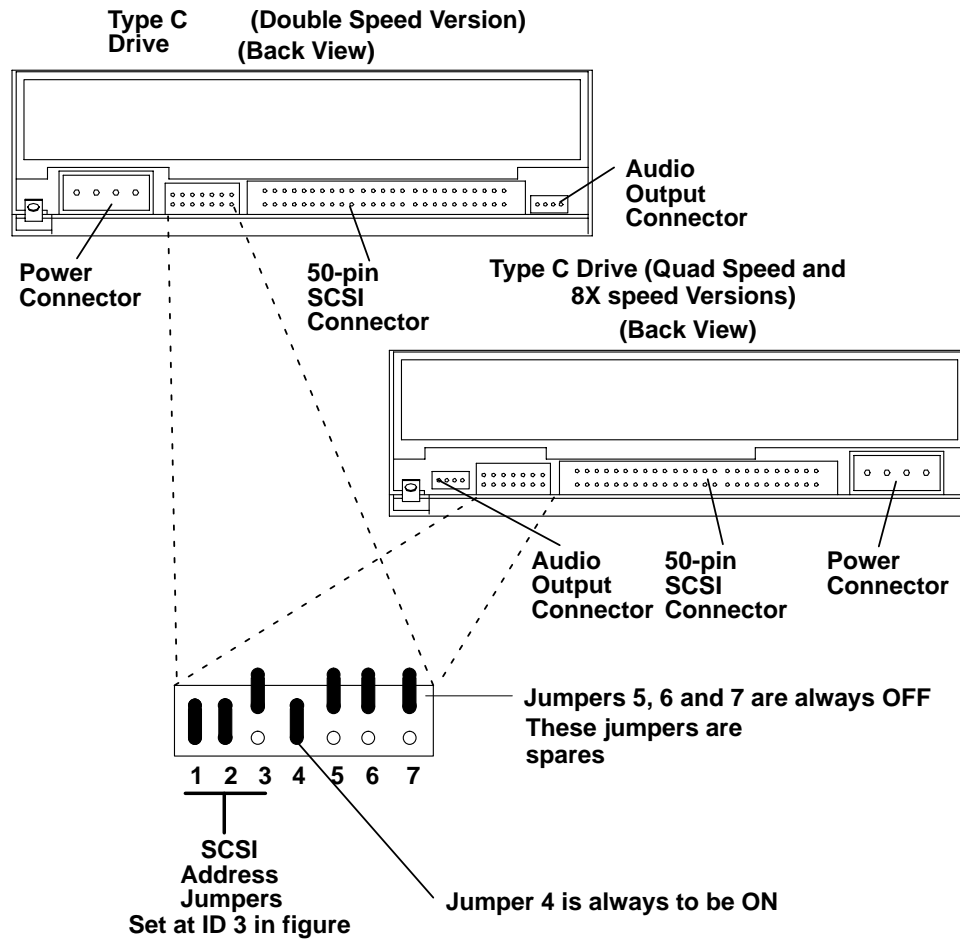

Address	Jumper 1	Jumper 2	Jumper 3
0	Off	Off	Off
1	On	Off	Off
2	Off	On	Off
3	On	On	Off
4	Off	Off	On
5	On	Off	On
6	Off	On	On

Manually Removing the Disc

Note: Use the following manual procedures only after other methods have not worked successfully.

The normal way to remove a disc is to press and hold the load/unload button for about 2 seconds.

When a power or drive failure prevents the disc from unloading normally, use the procedure that applies to the appropriate CD-ROM drive type A, B or C.

Type A Drives

1. Remove the drive from the system unit or 7210 using the procedures in the installation and service guide for that system unit or device.
2. Lay the drive upside down on a flat surface.
3. Remove the two loader motor mounting screws from the bottom of the drive.

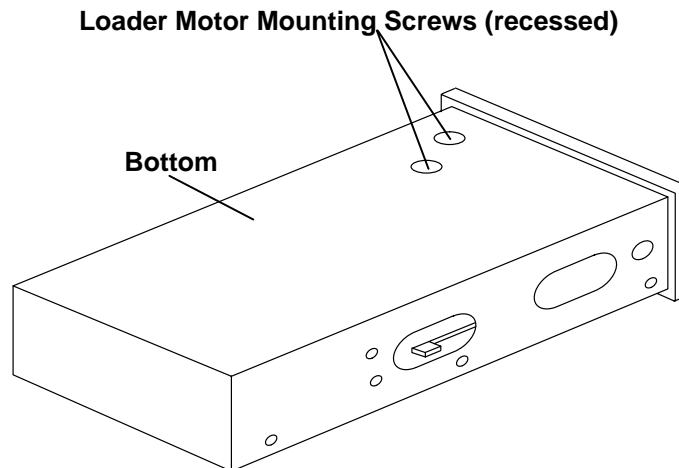

4. Turn the drive over to allow the loader motor mount to slip down and disengage the gears.

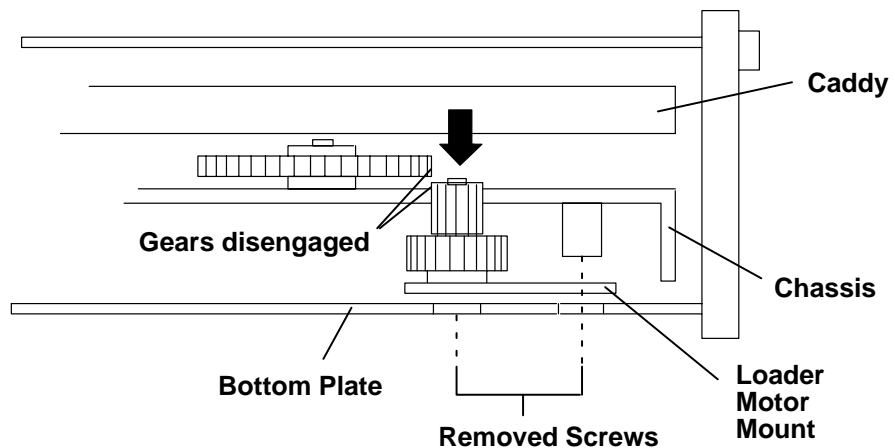

5. If the gears disengage, you should be able to remove the caddy by sliding the lever on the side of the drive toward the chassis front.

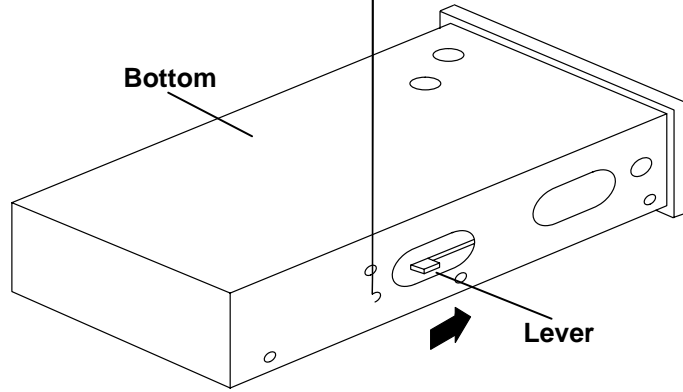

Type B Drives

1. Turn off power to the CD-ROM drive.
2. Remove the front bezel.
3. Remove the small label that covers the emergency eject hole.

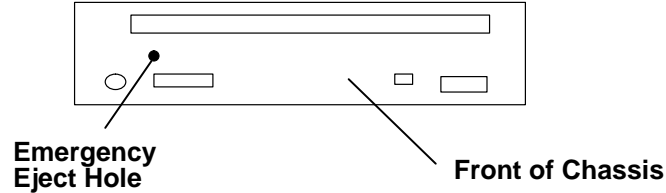

4. Insert a solid metal rod (such as a small Phillips screwdriver) not more than 25 mm (1 in.) into the emergency eject hole, and push; the caddy should be ejected.

Note: Use a rod having a diameter of 2.0 mm (.080 in.) or less, and do not insert the rod more than 25 mm (1 inch) into the emergency eject hole. Inserting a rod further than 25 mm (1 inch) may damage the CD-ROM drive.

5. Reassemble the drive in reverse order.

Note: The CD-ROM-2 Type B drives have a white underside on their unload buttons.

Type C Drives

Note: Execute the following procedure only in an emergency (ie. tray does not eject after pressing the load/unload button).

1. Power-off the system unit.
2. Insert a small diameter rod, such as a straightened paper clip into the emergency eject hole. (Refer to the illustration below for the location of the emergency eject hole.)
3. Push the tool in until some resistance is felt.
4. Maintain a small amount of pressure on the rod while lifting up on the tray with your finger nail.
5. Pull the tray open and lift out the disc.

Note: Normally the tray makes a ratcheting sound when pulling it open using the above procedure. This does not damage the drive.

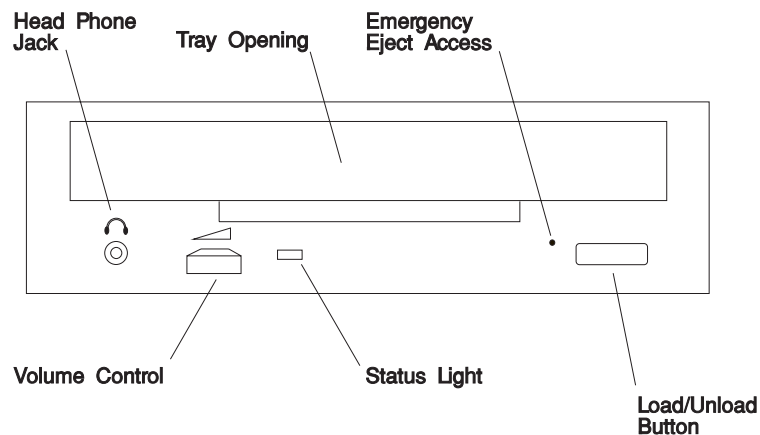

Vertical Orientation

All three types of drives can be operated vertically as shown below. Since Type A and B drives use a caddy to hold the disc, no additional provisions are needed when operating vertically. Type A and B drives can be oriented in either vertical direction (ie. the eject button either up or down).

Since the type C drives use a tray, the normal orientation is such that the eject button is up. The two tabs at the bottom of the tray must be extended to hold the disc in place when operating vertically. This is also shown below. Since the double-speed version only has two tabs, it can only be oriented one way. Namely, the eject button needs to be up. However, the quad-speed and 8X speed versions have tabs on both sides of the tray. Therefore, they can be oriented either way the same as the type A and B drives.

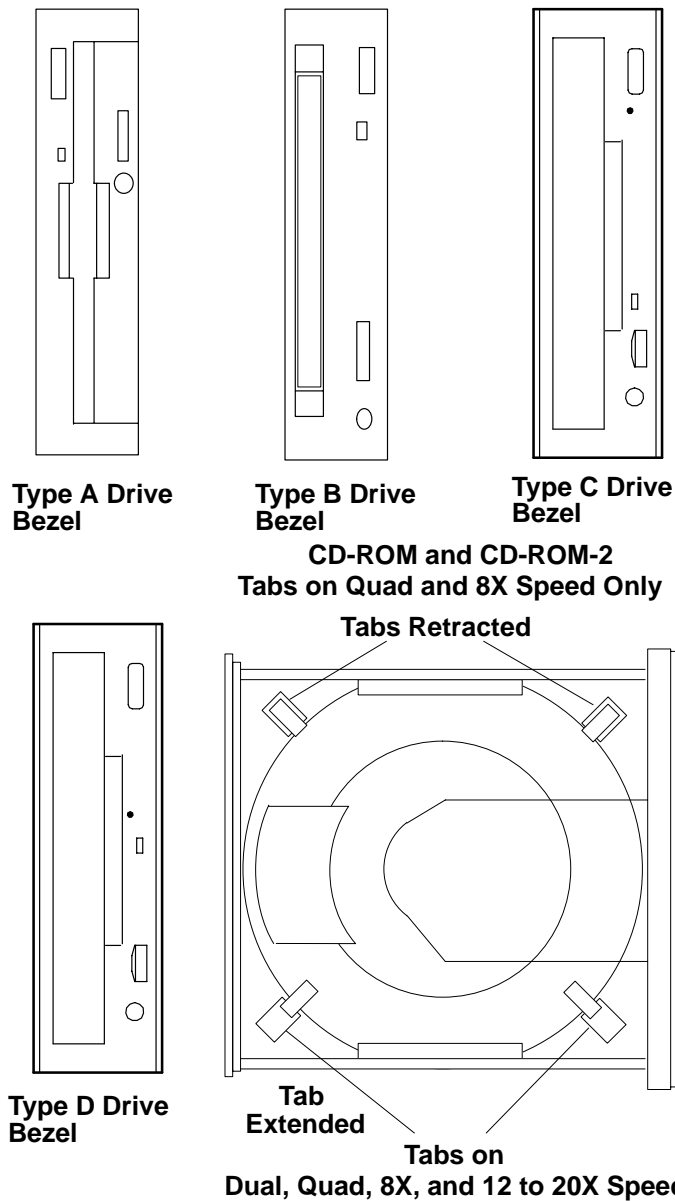

Terminator Resistors

Since terminators are already provided on the SCSI bus, terminator resistors are not installed on internal CD-ROM drives, socket locations for these resistors are provided on type A and type B CD-ROM drives as shown below. If terminating resistors are present on type A or B drives, remove them.

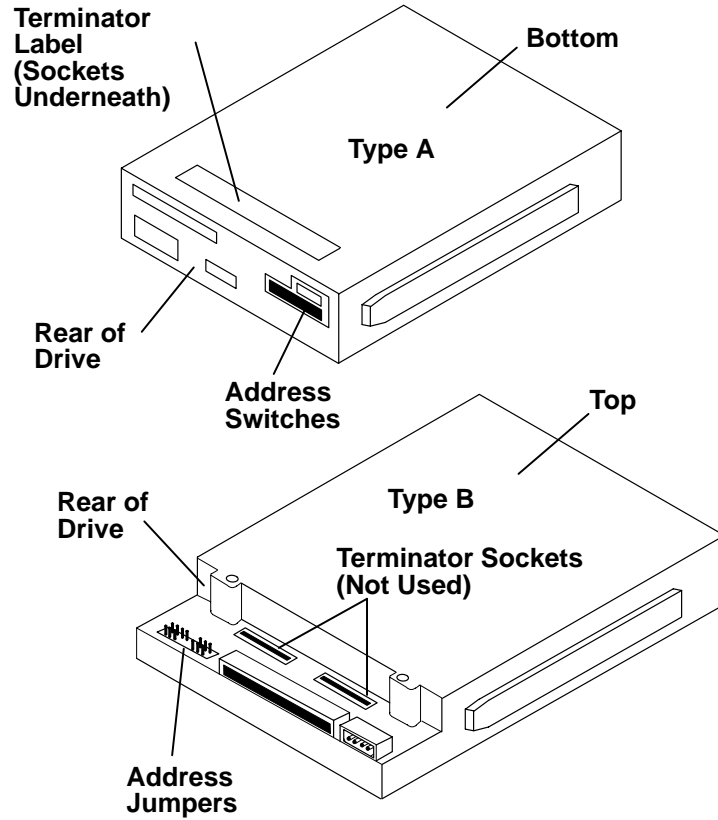

1/4-Inch Cartridge Tape Drives

The 1/4-inch cartridge tape drives use a tape cartridge to store data. The drives require a half-high position when installed in the front panel.

Setting the SCSI Address

The method of setting the SCSI address depends on internal or external installation of the tape drive.

Internal SCSI Address Connections

The SCSI address is set using preinstalled address jumpers 1, 2, and 3 on the rear panel of the drive (the jumpers may be labeled differently on the device).

The tape drive model determines whether the parity jumper is installed.

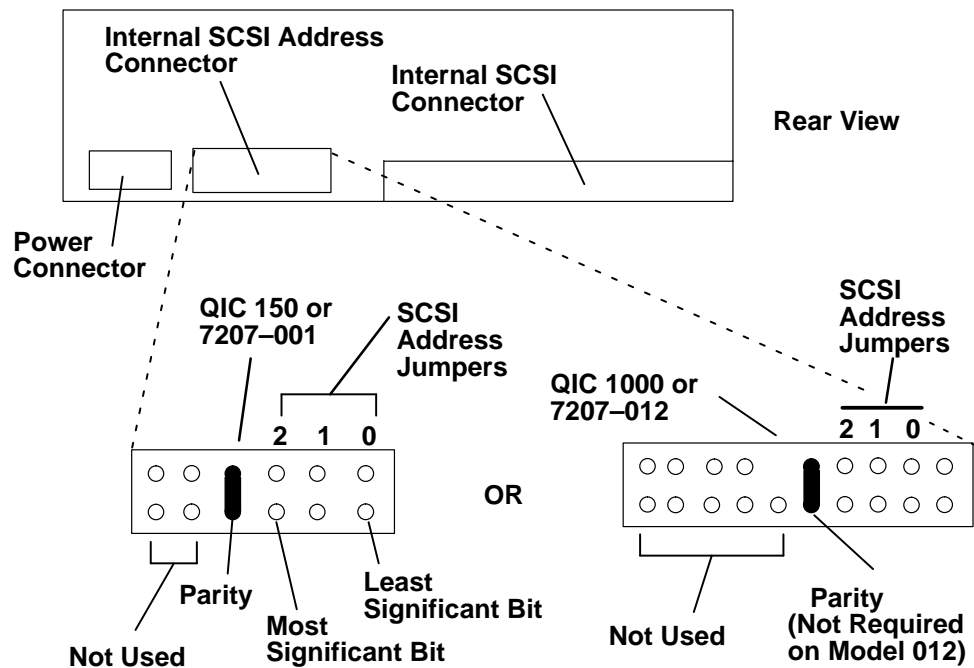

Valid Addresses

Address	Jumper 2	Jumper 1	Jumper 0
0	Off	Off	Off
1	Off	Off	On
2	Off	On	Off
3	Off	On	On
4	On	Off	Off
5	On	Off	On
6	On	On	Off

150M-byte, 525M-byte and 1.2G-byte 1/4-Inch Cartridge External Tape Drives

The 150 M-byte, 525M-byte and 1.2G-byte 1/4-inch tape drives use a tape cartridge to store data.

Setting the SCSI Address

Set the address switch shown to 6 or lower with a small screwdriver.

Note: The SCSI address switch must be set while the signal cable is disconnected from the device or while system unit power is off.

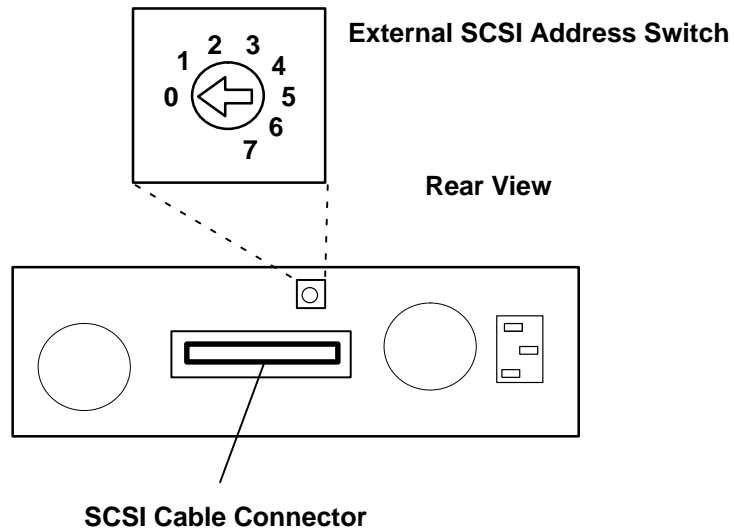

2.0G-byte 4-mm Tape Drive

The 2.0G-byte 4-mm tape drive uses a DDS|||| 4-mm tape cartridge to store data.

Note: This drive is available as an external installation only.

Setting the SCSI Address for External Installations

Attention: The SCSI address must be set while both system unit and tape drive power are turned off. Attaching the tape drive to an active system unit may damage the drive and/or the system unit.

To set an SCSI address for external installations, select an unused address number, and press the + or - pushbutton on the rear of the tape drive to display that number.

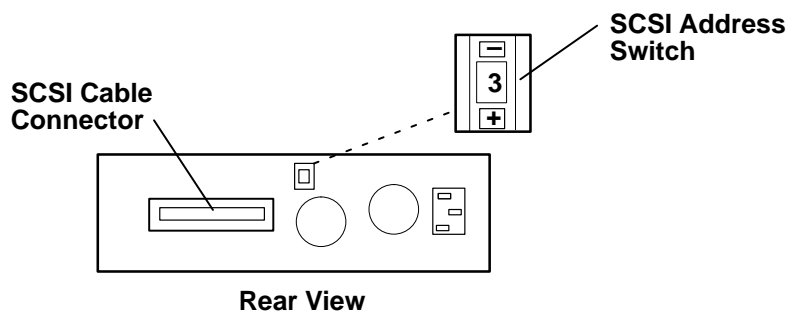

Manually Removing the Tape Cartridge

This procedure describes how to manually remove a data cartridge from a 2.0G-byte 4-mm Tape Drive.

Attention: This procedure is very delicate and could result in damage to your tape cartridge, 4-mm Tape Drive, or both. Please use this procedure only when you have exhausted the other options for removing the tape cartridge. These include:

1. Power the 4-mm Tape Drive off and on again to attempt to clear any potential hang conditions.
2. Issue the **Unload SCSI** command from the system command menu, if available, or press the Unload button on the tape drive.

Removing a Loaded Tape Cartridge

Perform the following steps to manually remove the tape cartridge from your tape drive.

1. Using the instructions in your system unit user's guide, power off your system unit and disconnect the tape drive.
2. Evenly lift and remove the cover from the base, avoiding extreme angles. Start lifting from the front of the drive to avoid the cover lip pulling off the door from the front panel.
3. If the cover clips get stuck, *do not* push them in by hand. Instead, lever between the base and the cover gently. Open up the base so that the clips are freed and, at the same time, pull up on the cover. If this still does not work, *carefully* press in the clips that are stuck so they are not caught and try again to lift off the cover.

Note: Remember, the front clips should *always* be lifted first.

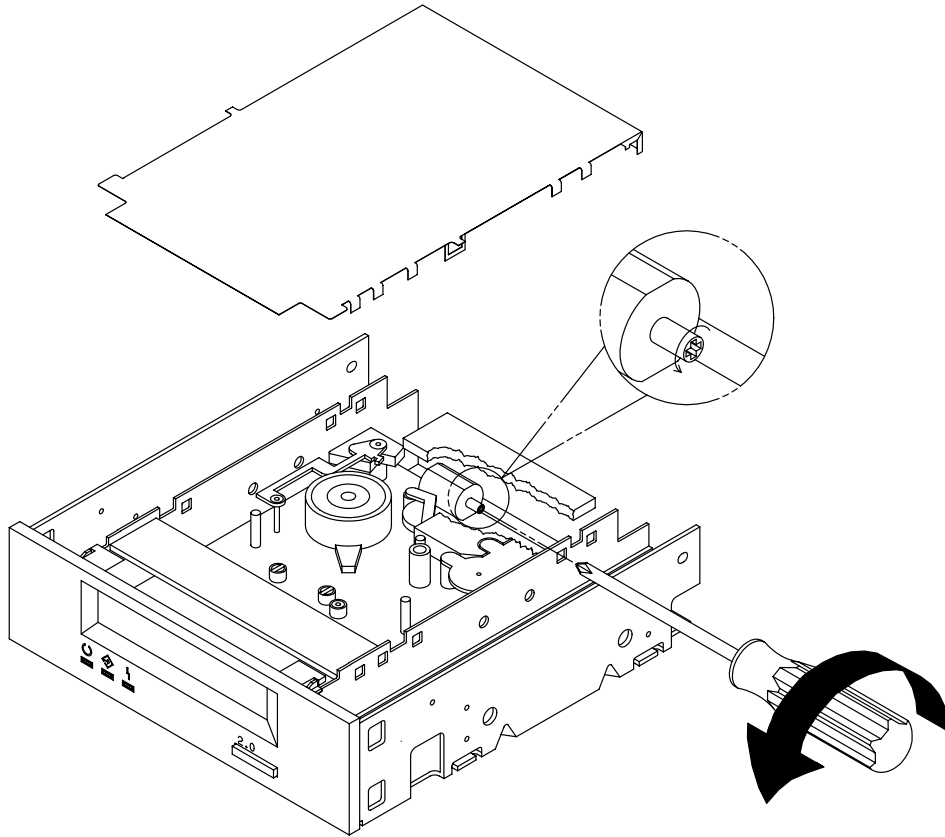

4. This illustration shows the manual method of removing the cartridge. Insert a Phillips #0 screwdriver with a 3-inch long, 1/4-inch diameter shaft into the hole designated on the side of the drive. Engage it with the indented end of the worm drive. Turn the screwdriver counterclockwise until the cartridge is ejected. Many turns may be needed before this happens. If the tape is loaded in the tape path of the drive, it could take approximately 4 minutes to remove the cartridge.

Note: If the tape is already within the cartridge housing, the procedure takes less time.

4.0G-byte 4-mm Tape Drive

The 4.0G-byte 4-mm tape drive uses either DDS||| or DDS2 MRS 4-mm tape cartridges to store data. This drive requires a half-high position when it is installed in the front panel.

Setting the SCSI Address for External Installations

Attention: The SCSI address must be set while both system unit and tape drive power are turned off. Attaching the tape drive to an active system unit may damage the drive and/or the system unit.

To set an SCSI address for external installations, select an unused address number, and press the + or - pushbutton on the rear of the tape drive to display that number.

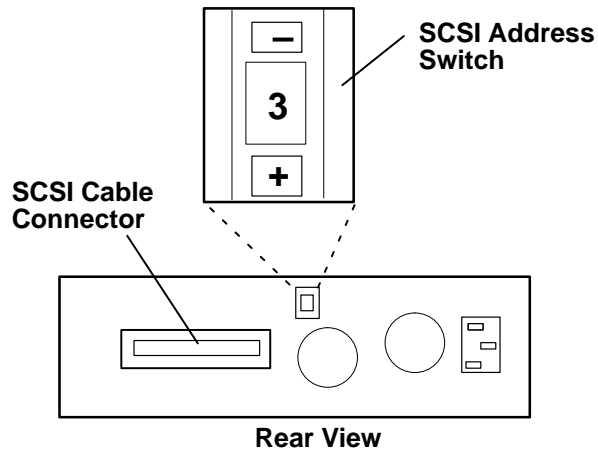

4.0GB 4-mm Tape Drives

There are two types of 4.0GB 4-mm tape drives. They are designated as type A and B. The two drives can be identified by looking at the rear of the drives or at the ventilation holes on the drive chassis. The type A drives have the 50 position SCSI connector at the top of the drive at about the center and has elongated ventilation holes in the chassis. The type B drives have the SCSI 50 position SCSI connector and the power connector across the bottom of the drive and has circular ventilation holes in the chassis.

Setting the SCSI Address for internal installations

Attention: The SCSI address must be set while both the system unit and the tape drive are turned off. Attaching the tape drive to an active system unit may damage the drive and/or the system unit.

Note: Prior to installing the SCSI media device into the media bay, the address of the device must be set to any of the available SCSI addresses.

Do not change any of the other switches or jumpers that were set at the factory.

For Type A Drives

Set the SCSI address by using switches 1 through 3 as shown. The dip switch is located on the rear panel or the drive.

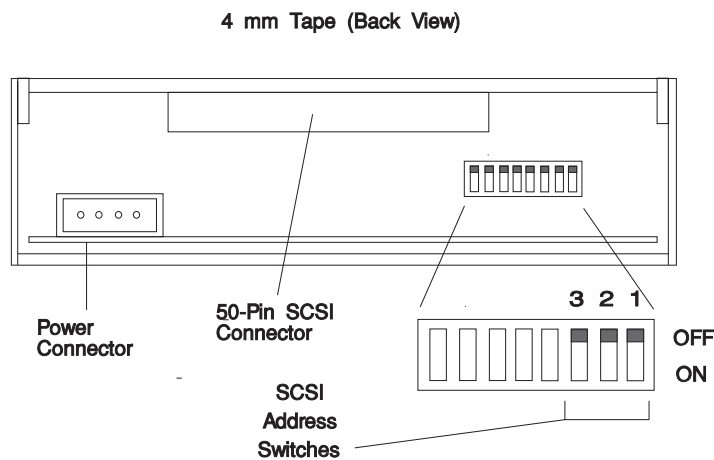

Address	Switch 3	Switch 2	Switch 1
0	Off	Off	Off
1	Off	Off	On
2	Off	On	Off
3	Off	On	On
4	On	Off	Off
5	On	Off	On
6	On	On	Off

For Type B Drives

Set the SCSI address by using jumpers 1 through 3 as shown. The address pins are the rightmost pins of the jumper block. The jumper block is located on the rear panel of the drive.

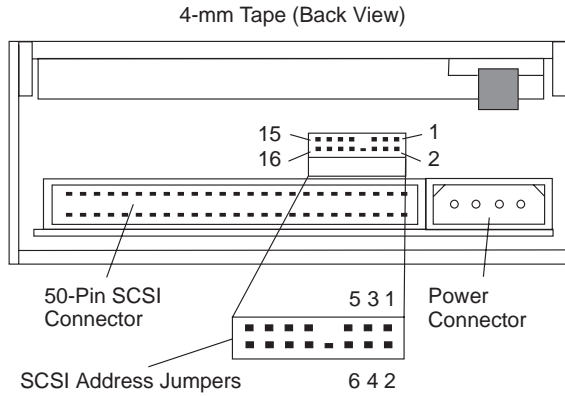

Address	Jumper 5-6	Jumper 3-4	Jumper 1-2
0	Off	Off	Off
1	Off	Off	On
2	Off	On	Off
3	Off	On	On
4	On	Off	Off
5	On	Off	On
6	On	On	Off

Manually Removing the Tape Cartridge from a 4-mm Tape Drive

This procedure describes how to manually remove a stuck data cartridge from a 4.0GB 4-mm Tape Drive.

Attention: This procedure is very delicate and could result in damage to your tape cartridge, 4-mm Tape Drive, or both. Please use this procedure only when you have exhausted the other options for removing the tape cartridge. These include:

1. Power the 4-mm Tape Drive off and on again to attempt to clear any potential hang conditions.
2. Issue the Unload SCSI command from the system command menu, if available, or press the Unload button on the tape drive.

Removing a Loaded Tape Cartridge

Perform the following steps to remove the tape drive from the system unit:

1. Disconnect the power to the system unit.
2. Disconnect the tape drive from the system unit.
 - Disconnect the SCSI connections to the host system.
 - Disconnect the power connections to the tape drive.
3. Remove the tape drive and any attached mounting hardware from the system unit.

Type A Drives

1. Remove the mounting brackets by removing the four screws near the lower edge of the tape drive assembly (two on each side) that are accessed through holes in the side of each bracket.

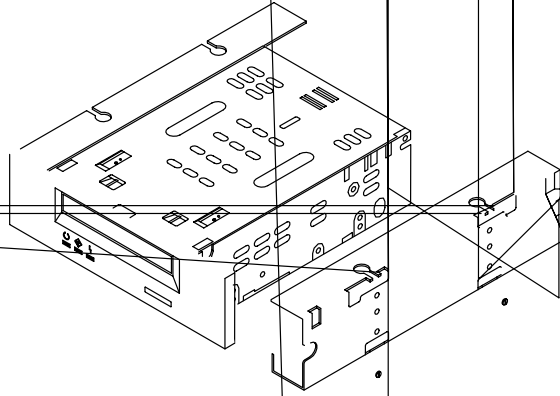

drive assembly). Continue to press on the bezel tab until the latch on the bezel tab clears the hole and the bezel can be pulled away from the drive assembly.

Note: The bezel cannot be completely removed because of the Light Emitting Diode (LED) printed circuit board assembly.

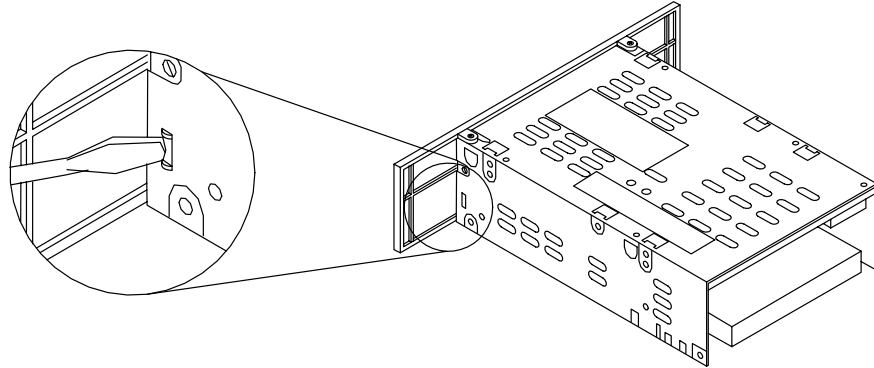

A4AA0219

c. Move the bezel aside to provide access to the front of the drive assembly.

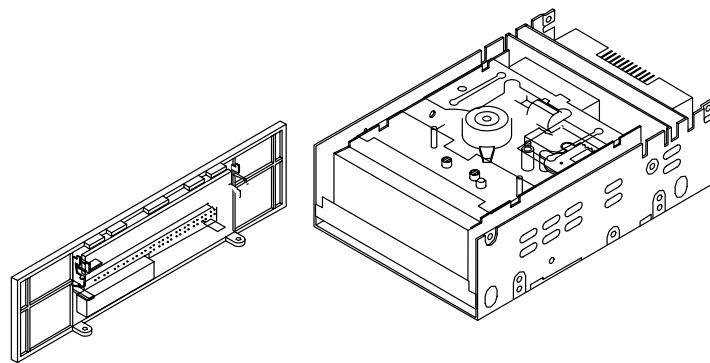

6. Use a small screwdriver to rotate the rear cartridge gear counterclockwise until the cartridge ejects.
7. Reassemble the tape drive and reconnect it to the system unit.

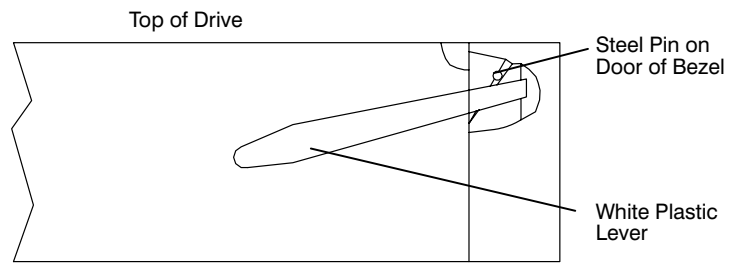

A4AA0222

Attention: When attaching the bezel, the cassette door should be raised to make sure that the steel pin on the left side of the door (with the drive assembly facing you) is above the white plastic lever on the left side of the drive assembly.

Type B Drives:

1. Remove the drive assembly from your system. Use the documentation that came with your system.
2. Remove the mounting rails by removing the four screws near the lower edge of the drive assembly (two on each side) that are accessed through holes in the side of each rail.

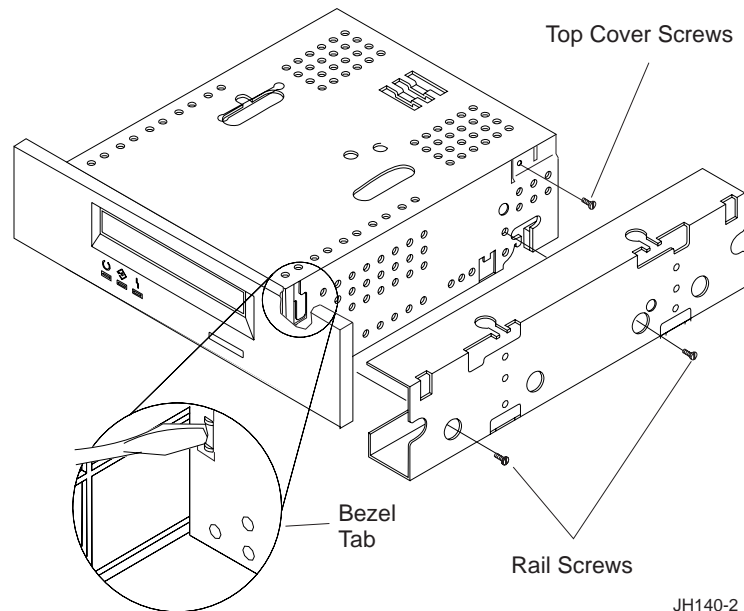

JH140-2

3. Remove the front bezel (the bezel snaps on).
 - a. Depress the bezel tabs (one on each side).
 - b. Pull the bezel down from the top.
 - c. Lift the bezel off of the bottom locating tabs.
 - d. Remove the bezel from the unit.
4. Remove the top cover (two screws).
 - a. Remove the two screws securing the cover to the drive (one on each side towards rear of drive).
 - b. Lift up on the rear of the top cover.
 - c. Remove the top cover from the drive.

Attention: The mode motor gear can be damaged if cycled in the wrong direction.

The following steps attempt to remove the tape from the drive without damaging the tape.

- a. Manually cycle the drive through an unload cycle until the tape is free of the drive mechanism.
 - b. Then, manually rotate the spindle to ensure the tape is pulled back inside the tape cartridge so that the tape is not be damaged when the cartridge door closes.
 - c. Complete the unload cycle until the tape ejects and can be removed from the drive.
5. The 0.25" diameter access hole **1** allows access to the mode gear. You can find it on the right side of the drive chassis near the back of the unit.

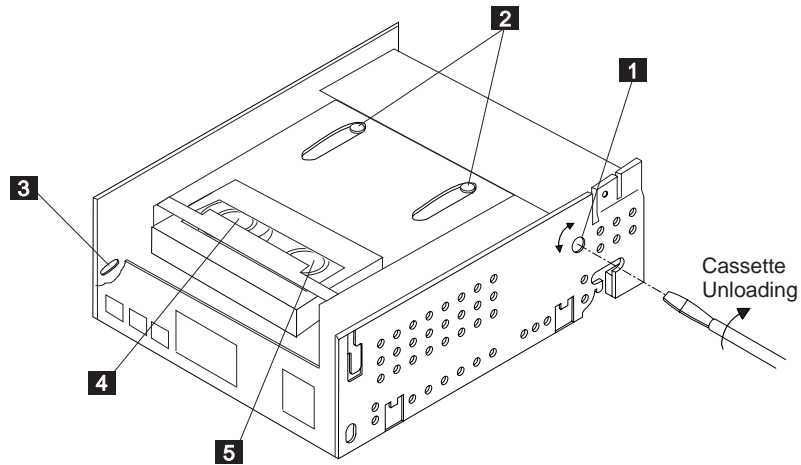

JH167-0

Right Side View of the Drive Chassis

6. With a small flat blade screwdriver, turn the mode motor gear inside the access hole, clockwise until the two pins **2** in the elongated slots begin to move toward the front of the drive (this can take up to 100 rotations of the screw driver).
7. Insert a small diameter allen wrench (or a similar tool) into slot **3**. Use it to rotate the left spindle **4** in a counter-clockwise direction by ratcheting the drive gear on the bottom of the spindle. This pulls the excess tape back into the tape cartridge.
8. Continue turning the left spindle until the right spindle **5** begins to move, indicating the tape is inside the cartridge.
9. Return to the 0.25" diameter access hole **1** and continue cycling the drive (in a clockwise direction) through the unload cycle until the tape cartridge ejects from the drive. This may take another 100 turns of the screwdriver.
10. Assemble the drive in reverse order.

12.0GB 4-mm Tape Drive

This section is used to set SCSI addresses and to give instructions for manually removing a stuck tape.

Setting the SCSI Address

Note: Prior to installing the SCSI media device into the media bay, the address of the device must be set to any of the available SCSI addresses.

Do not change any of the other switches or jumpers that were set at the factory.

The SCSI address is set using address pins located on the rear panel of the drive.

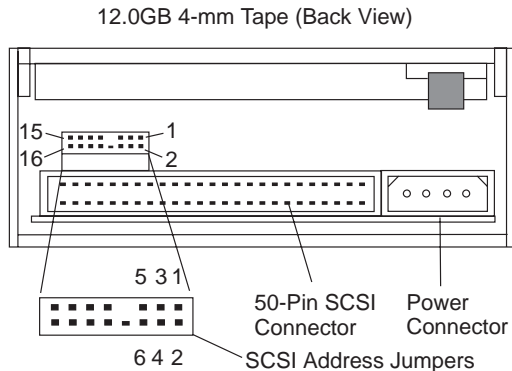

Address	Jumper 5-6	Jumper 3-4	Jumper 1-2
0	Off	Off	Off
1	Off	Off	On
2	Off	On	Off
3	Off	On	On
4	On	Off	Off
5	On	Off	On
6	On	On	Off

Note: The 12.0GB 4-mm tape drive is shipped with the three jumpers installed and set to address zero.

Manually Removing the Tape Cartridge from the 12.0GB 4-mm Tape Drive

Use the following procedure to manually remove the data cartridge.

If a power outage occurs while a tape cartridge is loaded or the automatic unload procedure fails, you may want to manually unload a cartridge from the drive. The following steps outline the manual tape cartridge unloading and removal procedure.

During this process you will need to remove the top cover and front bezel, access and turn the mode motor shaft, and access and rotate the drive reel motor sprockets in order to safely disengage the tape and remove tape cartridge from the drive.

Once the front bezel has been removed, you can access the tape drive reel motor sprockets from the front of the drive. Just below the cartridge opening and above the flex cable there is a opening for access to the supply and take-up reel sprockets. Manually rotating either one of these sprockets will move the tape as long as the cartridge reels are still minimally engaged.

Procedure:

1. For the external model:

- Remove the drive from your system using the documentation that came with your external drive.
- Remove the tape drive from the external covers. Turn the unit upside down and remove the four screws (two screws on each side) that attach the external cover to the drive unit. Remove the exterior cover and retain the screws.

2. For the internal model:

- Remove the drive assembly from the computer using the documentation that came with your system.

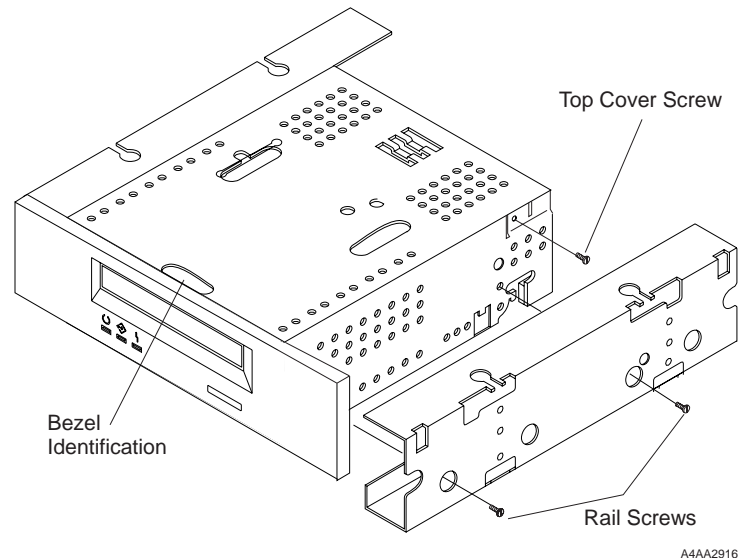

- For internal models with rails, remove the mounting rails by removing the four screws near the lower edge of the unit (two on each side) that are accessed through holes in the side of each rail.
 - Remove the front bezel by pulling out on the top of the bezel at the indentation.
3. Remove the top cover of the drive unit by removing the two screws at the top edge near the rear of the unit (one on each side). Save the screws in a safe place.

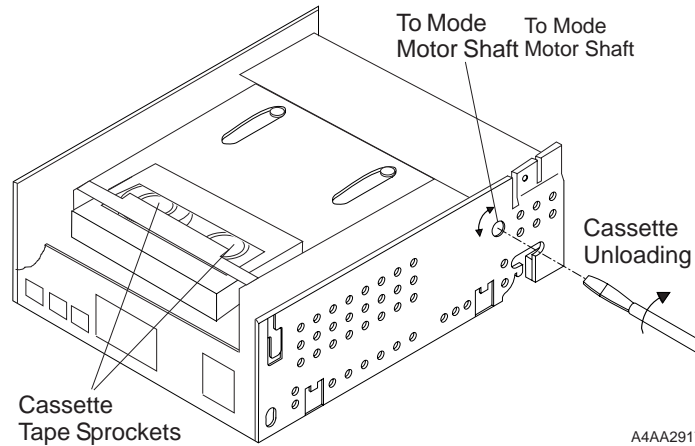

A4AA2917

The following steps attempt to remove the tape from the drive without damaging the tape. In the following steps it can take more than 100 turns (revolutions) of the screwdriver before the tape cartridge can be removed.

Attention: The mode motor gear can be damaged if cycled in the wrong direction. **DO NOT** turn the mode motor shaft counterclockwise.

4. Insert a small (precision) screw driver in the hole on the right side of the drive near the rear and begin turning the mode motor shaft clockwise.

As you turn the shaft clockwise, you can see the tape drive's guidance rollers slowly retract. Once completely retracted it is necessary to access the tape drive reel sprockets to rewind all of the exposed tape into the tape cartridge so that the tape is not damaged when the cartridge door closes. See illustration on page 2-28.

Note: Be sure to rewind all of the loose tape back into the cartridge before completing cartridge removal since tape damage can occur.

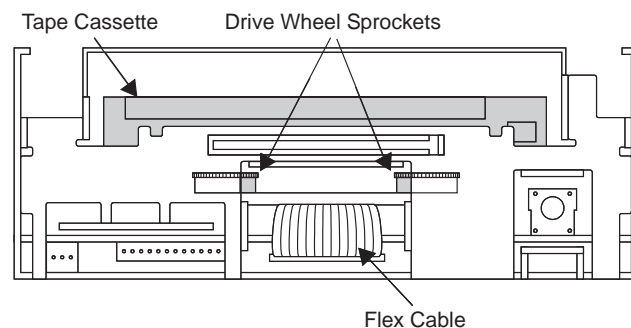

Once the tape drive guidance rollers have fully retracted turn the drive so that you are facing the front. With a small **non-magnetic** probe access one of the drive reel sprockets and manually rotate the drive reels until all of the tape has been wound inside of the cartridge.

5. Once all the tape has been wound back into the cartridge, continue turning the mode motor shaft clockwise until the cartridge rises and protrudes from the slot and "clicks" free. Remove the cartridge.
6. Replace the top cover on the drive and secure it with the two screws that you removed.
7. For the external model:

- Reassemble the drive unit into the exterior cover using the screws that you removed.
 - Reconnect the drive to your system using the documentation that came with your external drive.
8. For the internal model:
- Replace the front bezel by angling the two plastic feet at the bottom of the bezel into the two aligning holes on the bottom of the unit. Then snap the top of the bezel into place.
 - For the internal model with rails, reattach the rails using the screws that you removed.
 - Reinstall and connect the drive unit in your system using the documentation that came with your external drive.

2.3G-byte 8-mm Tape Drive

The 2.3G-byte 8-mm tape drive uses an 8-mm tape cartridge to store data. This drive requires a full-high position when it is installed in the front panel.

Setting the SCSI Address

Note: When the drive is installed in a 7208, the address switches must be set to address 0.

The SCSI address is set using three switches on the rear panel of the drive. When the drive is installed in a 7208, an address cable is attached to the address jumper block on the rear panel.

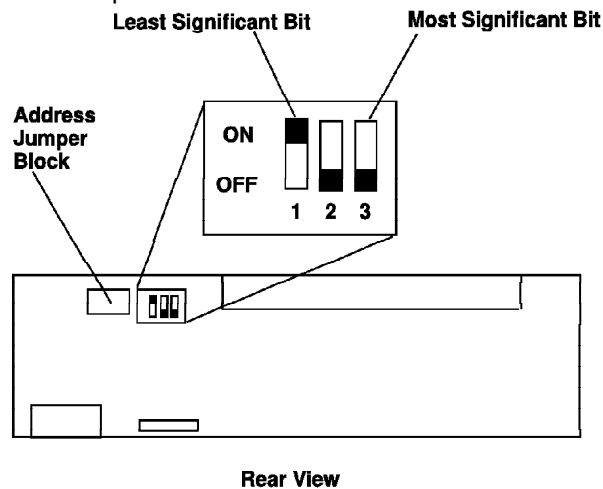

Valid Addresses

Address	Switch 1	Switch 2	Switch 3
0	Off	Off	Off
1	On	Off	Off
2	Off	On	Off
3	On	On	Off
4	Off	Off	On
5	On	Off	On
6	Off	On	On

Manually Removing the Tape Cartridge

When a power or drive failure prevents the cartridge from ejecting, the cartridge may be removed manually.

The following tools are required to remove the cartridge from the tape drive:

- 3/8 inch flat blade screwdriver
- Pointed tweezers or small screwdriver

- Number T8™ Torx driver
- Number T10 Torx driver
- Tape
- 6-volt lantern battery.

The manual removal requires partial disassembly of the tape drive. Follow the listed steps exactly as stated. Read all of the information contained in this procedure completely before attempting to remove a cartridge.

Do only as many parts of the following procedure as are required to free the cartridge.

Part One of the Cartridge Removal Procedure

1. Use the removal procedure in your systems *Installation and Service Guide* to remove the tape drive.
2. Remove the top cover to the drive. To do this, remove the screws shown in the following illustration.
3. Refer to the illustration on page 2-34. If the tape has been extracted from the tape cartridge and follows the tape path denoted by the heavy black line, continue with this procedure. If the tape has not been extracted from the cartridge, go to the “Door Release and Tape Rewind Procedure” on page 2-37.

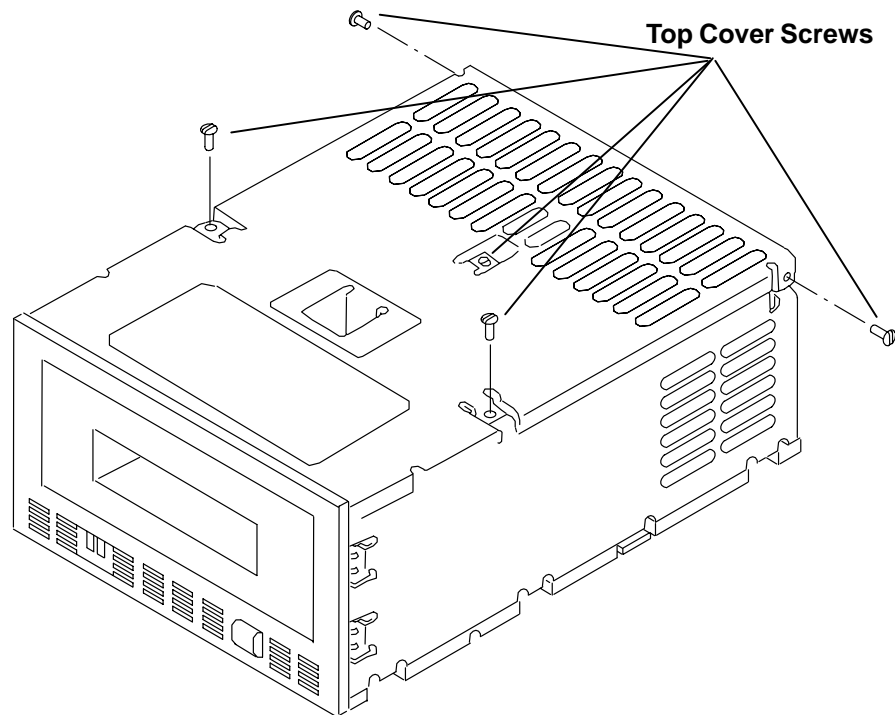

Attention: Do not touch the tape on the outside of the loop, that is the surface of the tape where data is recorded.

The cartridge door must be taped open to prevent the door from closing on the tape before it is returned to the cartridge. To tape the door open:

4. Use two pieces of tape approximately 2-1/2 inches long. Position the two pieces of tape as shown in the illustration, and gently press the tape to the cartridge.

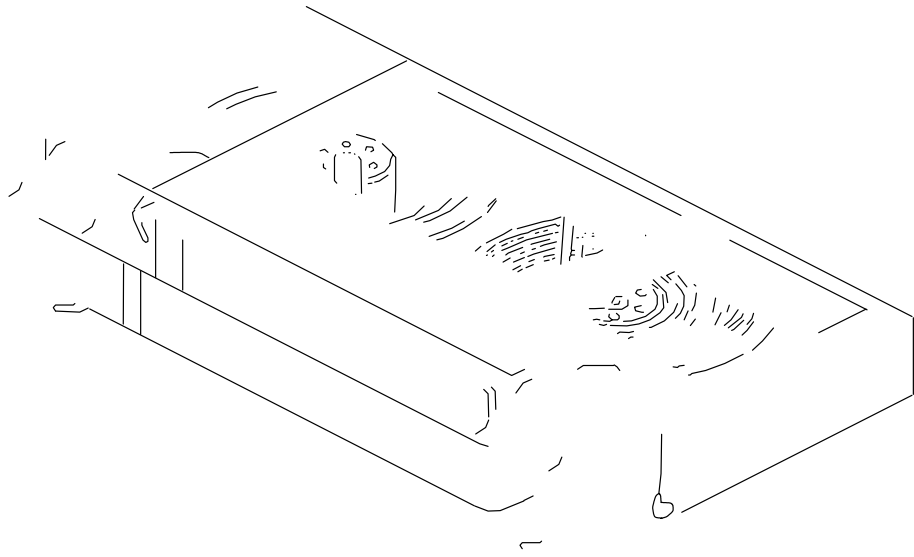

drive still fails to unload, go to the “Second Part of the Cartridge Removal Procedure” on page 2-33.

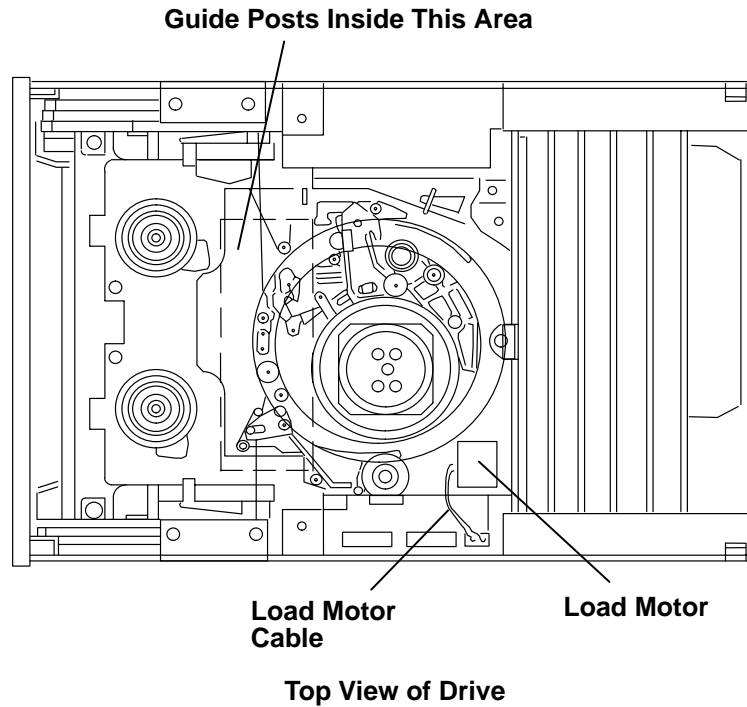

Second Part of the Cartridge Removal Procedure

1. Remove the bottom cover.
2. Remove the servo card.
3. To prevent damaging the servo board or the wires and connectors, disconnect all of the connectors from the servo board, and be sure to note where they connect.

Use a small screwdriver or similar tool to push on the key in the center of the connector. Push the connector away from the servo board. Start by removing the connectors closest to the rear of the drive.

4. Refer to the following illustration to locate the load motor and gears that control the load mechanism.

Locate gear number 4 in the illustration; use this gear to return the load mechanism to the unload position.

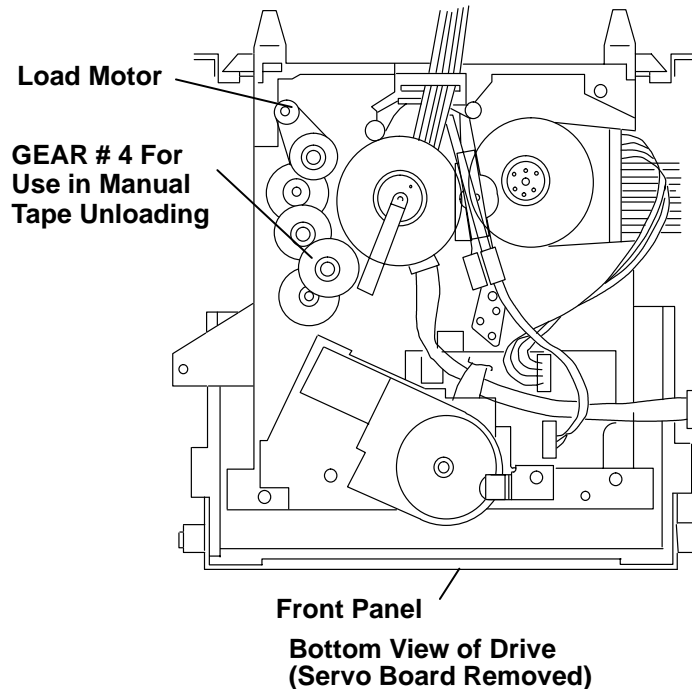

5. Tilt the drive so that you can see the tape load mechanism and the guide posts. While holding the drive in this position and watching the load mechanism, use your thumb to turn gear number 4. Turn the gear in a counter clockwise direction as viewed from the bottom of the drive.

Continue to turn the gear until the load ring and all guide posts have returned to their unload positions. The load ring stops moving before all guide posts and rollers have retracted to their unload positions. Continue to turn the gear until the guide posts stop moving. The gear should be rotated slowly and without jerking the tape to prevent damaging the tape. The load mechanism is in the unload position when all guides, posts, and rollers on the load ring, and all other guide posts are approximately in a straight line closest to the tape.

6. If the tape unloaded, go to "Door Release and Tape Rewind Procedure" on page 2-37.

If you were not able to unload the tape, go to the "Third Part of the Cartridge Removal Procedure."

Third Part of the Cartridge Removal Procedure

Attention: This procedure has the highest potential for damage to the tape and to the heads of the drive. Use care during this procedure.

1. Refer to the illustration and remove the screw that secures the erase head bracket; lift the erase head bracket straight up.

The connector and wires do not have to be removed from the servo board. There is sufficient slack in the wires to allow the erase head bracket to be removed.

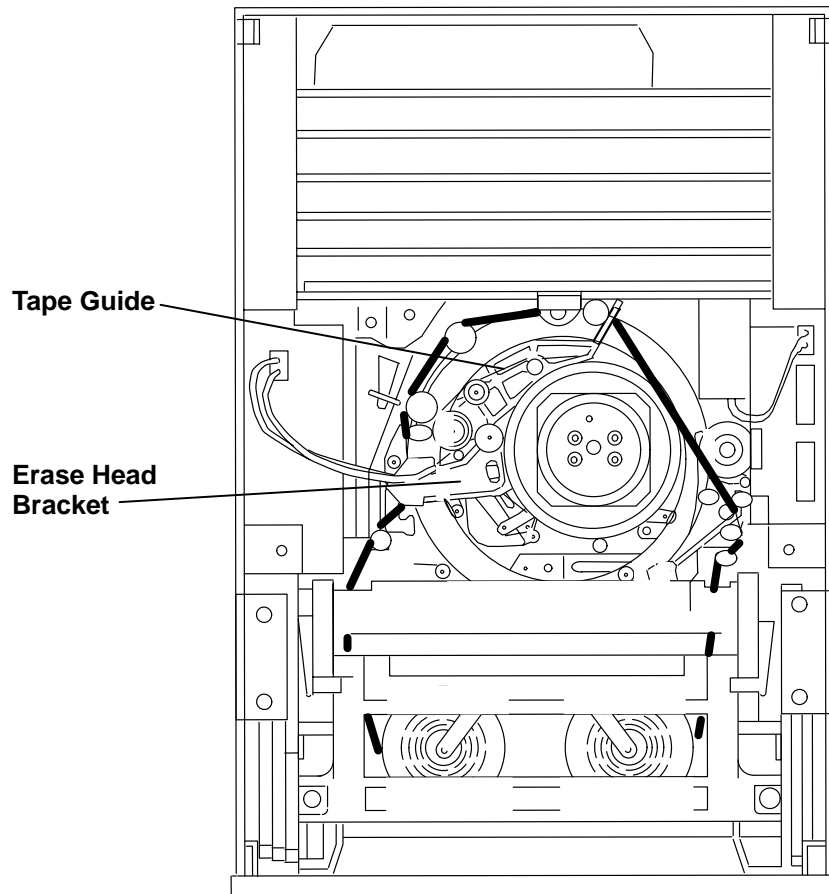

Top View of Drive

2. To remove the tape guide, lift it straight up.

The heavy black line represents the tape path. Use a nonconductive tool, such as a molded potentiometer adjustment tool when removing the tape from the guide posts and rollers. Whenever this procedure describes the use of the tool, the tool must touch the side of the tape where no data is recorded. If you are unsure of which side of the tape to touch with the tool, carefully inspect the tape path before starting this procedure. The side of the tape that comes in contact with the rotating drum is the side where data is recorded. The tool must only be used to touch the opposite side.

3. Use the tool to loosen the tape at point 1. While touching the side of the tape where no data is recorded, move the tool toward the rear of the drive. This action should cause the tape to pull off of the takeup reel and make a loose loop.
4. Move the pinch roller flange toward the side of the drive, and hold it in this position. This action releases the pinch roller. Insert the tool in the tape loop at approximately point 2.

Attention: Once you start to remove the tape from between the pinch roller and the capstan, *do not* release the pinch roller until the tape is completely clear of this area. If the pinch roller is released during this part of the procedure, before the tape is clear of these components, the tape will be damaged.

- Remove the tape from around the guide posts and rollers at point 3 and point 4, being sure to place the tool inside the tape loop, that is, on the nonrecorded side of the tape.

Point 5 is an *L-shaped* molded black plastic part. The *L-shaped* part is mounted upside-down to prevent the tape from riding up on the rotating drum. Care must be taken so that the tape is not creased or damaged in any way during tape removal.

- Position the tool between points 4 and 5 inside the tape loop and gently move the tape up so that it passes between the *L* and the top edge of the drum.
- Remove the tape from around the guide posts and roller at point 6; be sure to place the tool inside the tape loop.

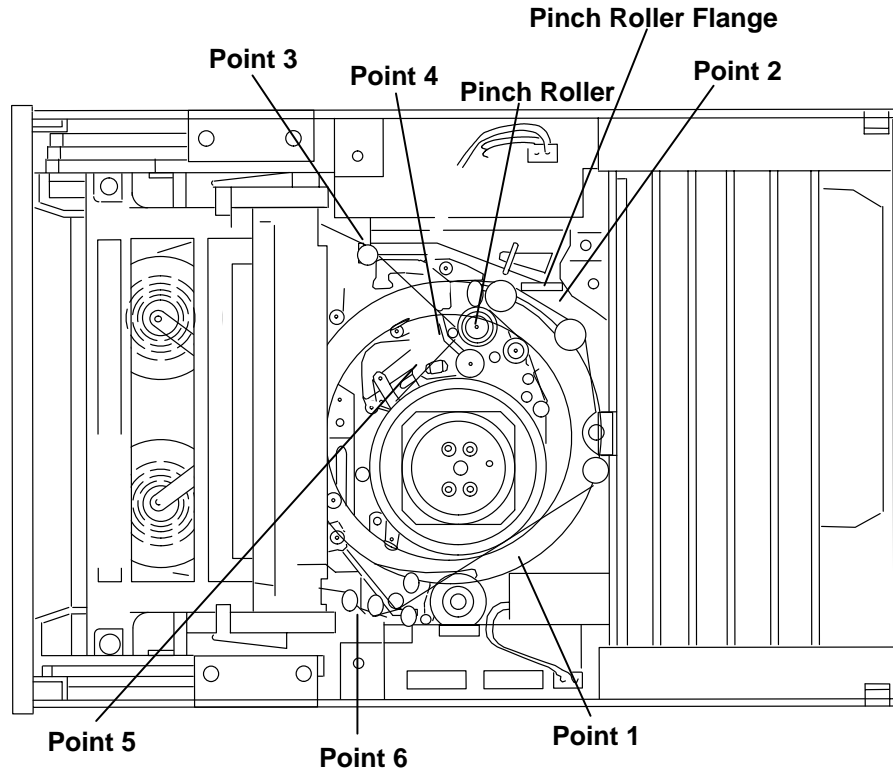

Top View of Drive

8. Go to “Door Release and Tape Rewind Procedure.”

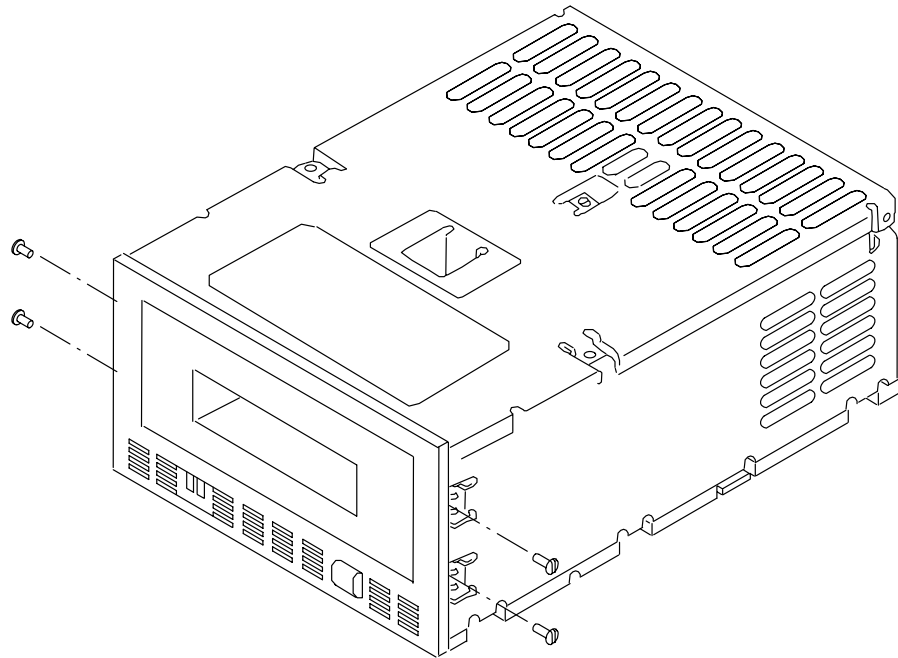

Door Release and Tape Rewind Procedure

1. Use a small screwdriver to move the drive door release lever toward the front of the drive.

Care must be taken when removing the drive door components with the data cartridge still in the drive. When opening the door, control the rate at which it opens by holding the door with your fingers so that it opens more slowly. This prevents the data cartridge from moving quickly and damaging the loose tape.

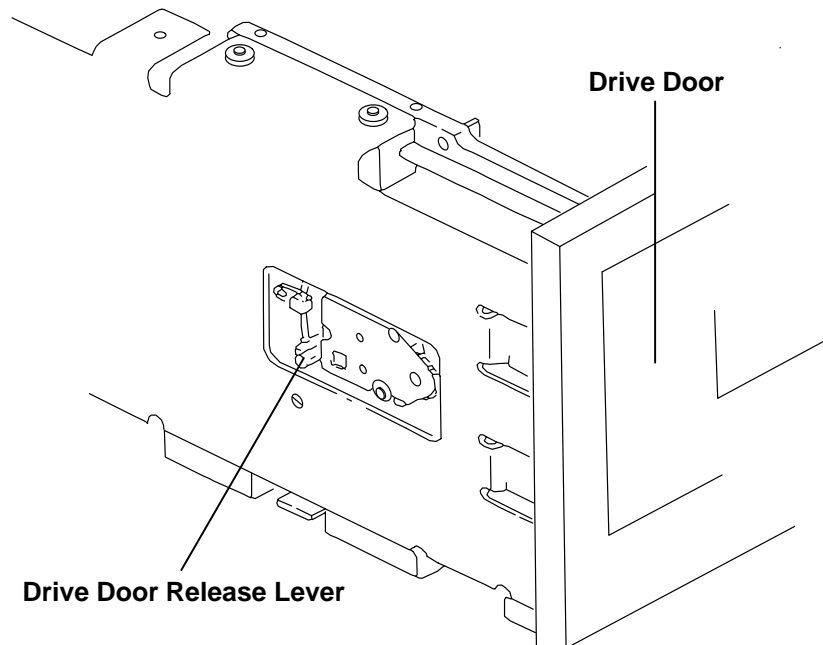

2. Release the two latches on the drive door, then remove the front and back parts of the door assembly from the door hinge.

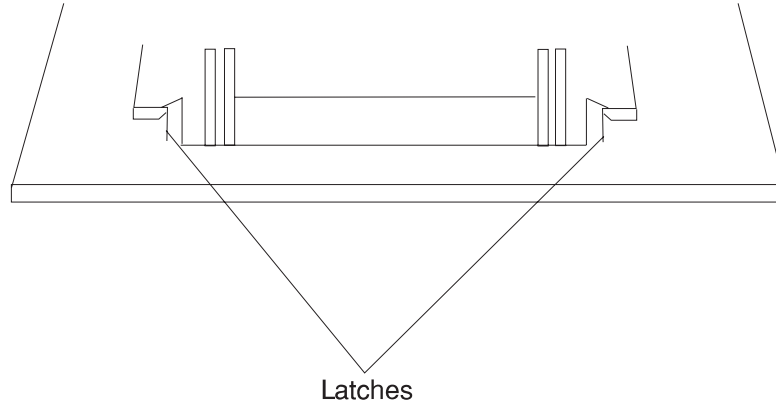

With the door open, position the drive so that it is resting on the rear of the frame, with the door facing up and the bottom of the drive facing you. Use a flat blade screwdriver and insert it into the hub of the takeup reel; this is the hub on the right with the drive in the current position.

3. When the screwdriver is inserted in the hub, turn the hub counter-clockwise slowly.

While turning the screwdriver, watch the tape loop to ensure that it does not get caught on any of the components. *If the tape gets caught, free the tape from the obstruction before turning the hub any further.*

Attention: Do not touch the tape on the outside of the loop, that is the surface of the tape where data is recorded. Make sure that all of the loose tape has been wound into the cartridge. If all of the tape is not in the data cartridge, the tape will be damaged by the cartridge door. Do not overwind the tape into the cartridge once the loose tape has wound onto the takeup reel. Overwinding the tape results in tape damage.

4. When all of the loose tape has been wound into the data cartridge, remove the screwdriver.
5. Remove the scotch tape holding the door of the cartridge open.
6. Remove the cartridge.

To reassemble the tape drive, reverse the removal procedures.

5G-byte 8-mm Tape Drive

The 5G-byte 8-mm tape drive uses an 8-mm tape cartridge to store data. This drive requires a full-high position when it is installed in the front panel.

Setting the SCSI Address for External Installations

Attention: The SCSI address must be set while both system unit and tape drive power are turned off. Attaching the tape drive to an active system unit may damage the drive and/or the system unit.

To set an SCSI address for external installations, select an unused address number, and press the + or - pushbutton on the rear of the tape drive to display that number.

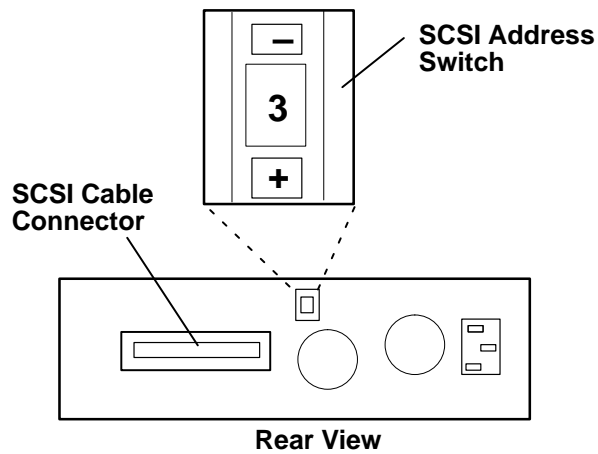

Setting the SCSI Address for Internal Installations

Attention: The SCSI address must be set while both system unit and tape drive power are turned off. Attaching the tape drive to an active system unit may damage the drive and/or the system unit.

Rear View of Tape Drive

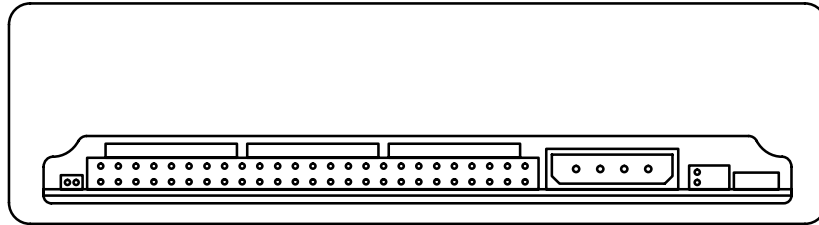

Manually Removing a Loaded Tape Cartridge

Use the following removal procedure when a tape cartridge has been loaded into the tape path:

Attention: This procedure destroys the tape.

1. Remove the five screws from the top cover of the tape drive.

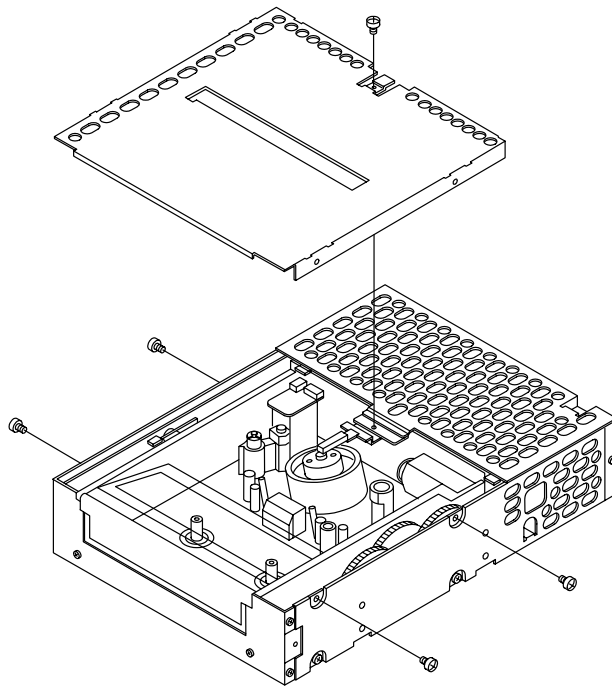

A4AA0223

2. Using tweezers, loosen the tape as shown in the illustration on the following page. If the pinch roller is engaged, push the indicated spring to release the pinch roller and loosen the tape.

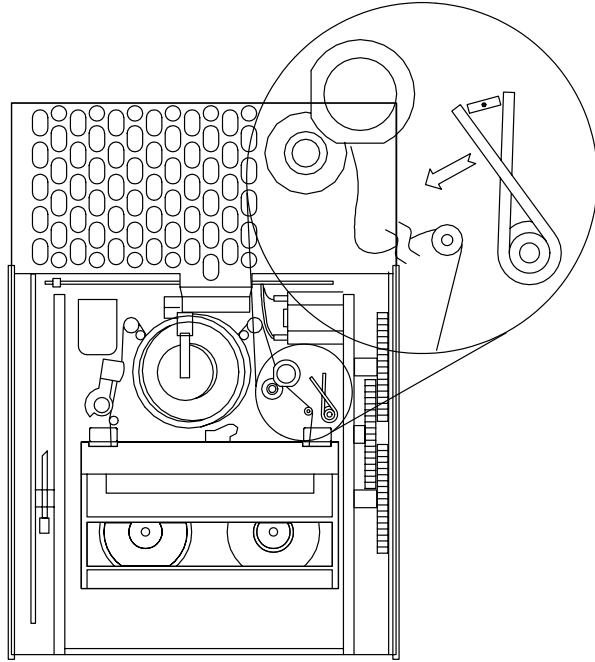

20.0GB 8-mm Tape Drive

This section is used to set SCSI addresses and to give instructions for manually removing a stuck tape.

Setting the SCSI Address

Note: Prior to installing the SCSI media device into the media bay, the address of the device must be set to any of the available SCSI addresses.

The SCSI address (ID) is set by placing jumpers on the address pins located on the rear panel of the drive. See table of Valid Addresses (SCSI IDs) on page 2-44.

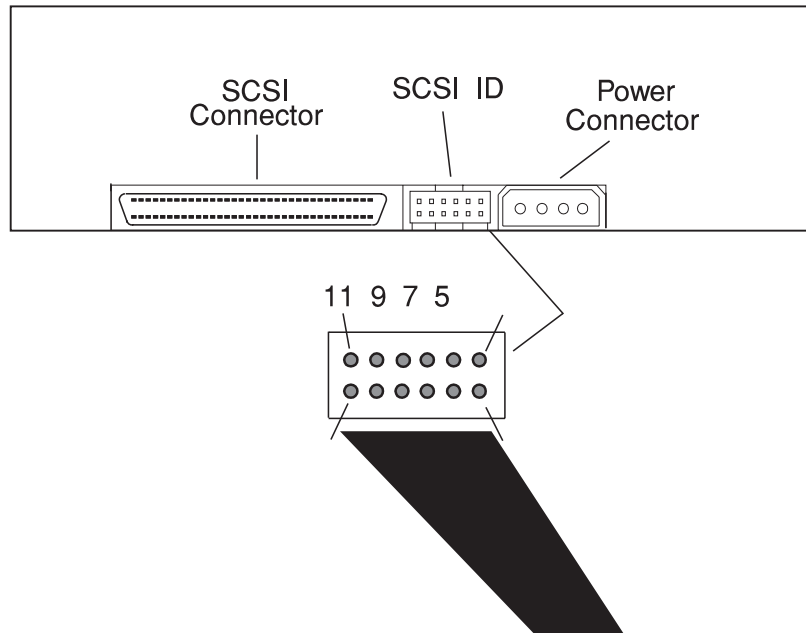

Valid Addresses (SCSI IDs)

Address	Jumper 7-8	Jumper 5-6	Jumper 3-4	Jumper 1-2
0	Off	Off	Off	Off
1	Off	Off	Off	On
2	Off	Off	On	Off
3	Off	Off	On	On
4	Off	On	Off	Off
5	Off	On	Off	On
6	Off	On	On	Off
7*	Off	On	On	On
8	On	Off	Off	Off
9	On	Off	Off	On
10	On	Off	On	Off
11	On	Off	On	On
12	On	On	Off	Off
13	On	On	Off	On
14	On	On	On	Off
15	On	On	On	On

Note:

1. Address 7 is reserved for the adapter.
2. The 20GB 8-mm tape drive is shipped with three jumpers installed.

Manually Removing the Tape Cartridge from an 20GB 8-mm Tape Drive

Use the following procedure to manually remove the data cartridge from a non-functioning 20GB 8-mm tape drive:

Attention: This procedure is very delicate, and could result in damage to the tape, the tape drive or both. Use this procedure only as the last option after you have attempted to clear the hang condition by powering the tape drive on and off.

Use the service information for your system to remove the tape drive. Then move the tape drive to a suitable work area.

1. Remove the three T6™ screws that hold the top cover of the tape drive. Remove the top cover. This will allow you to observe the tape unload progress.
2.

Alternate moving the drive's trolleys to ward the unloaded position and moving the supply reel motor to take up slack in the media. Do not touch the media itself. As the drive faces you, the trolleys are moved by inserting a 2.5mm Allen driver in the hole marked UNLOAD at the left rear and turning in the marked direction (clockwise). The supply reel motor is moved by inserting a non-metallic probe into the hole marked UNLOAD on the drives bottom and turning in the marked direction (clockwise). The wooden end of a swab works well for this purpose. Alternate frequently, between moving the trolleys and taking up slack, to avoid damaging the media. Use of a metal tool may damage the supply reel motor. This process is complete when the trolleys stop moving and the media is fully retracted into the cartridge shell.
3. Unload the cartridge. As the drive faces you, the cartridge is unloaded by inserting a 2.5mm Allen driver in the hole marked UNLOAD at the left front and turning in the marked direction (counter-clockwise). This process is complete when the cartridge is ejected.
4. Replace the drive's top cover.

160MB SCSI Disk Drive

The 160MB SCSI disk drive is a 3-1/2 inch device which fits into a half-high media position.

Setting the SCSI Address

Notes:

1. The device is shipped with jumpers configured for Address 6.
2. All three terminating resistors must be removed before installing the drive.

The three-position address jumper block J3 is located on the fixed-disk logic card shown. Addressing information is given in the table below.

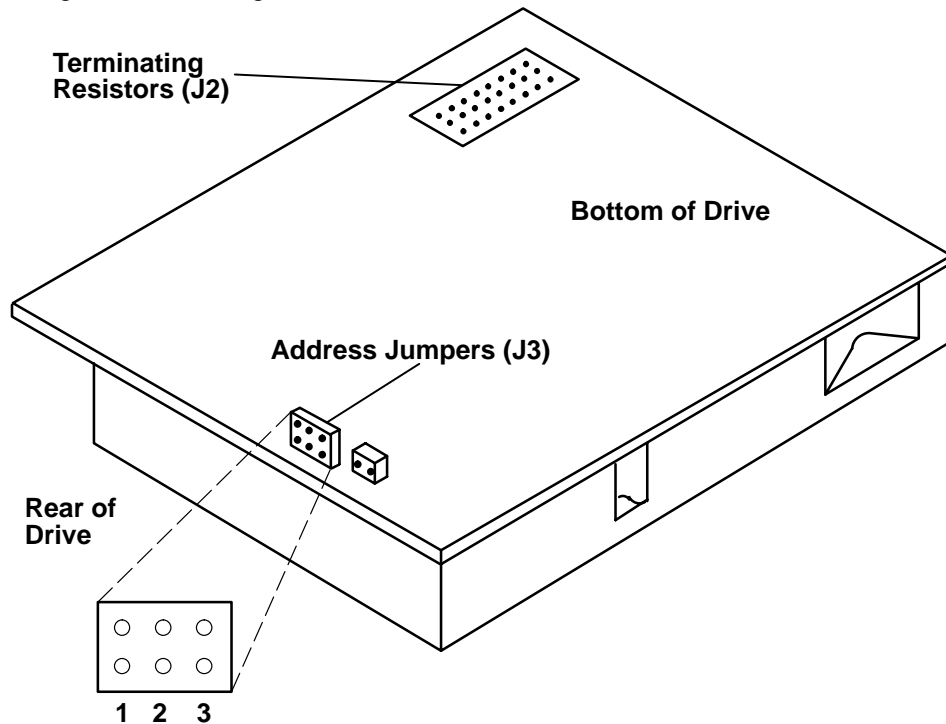

Valid Addresses

Address	Jumper 1	Jumper 2	Jumper 3
0	Off	Off	Off
1	On	Off	Off
2	Off	On	Off
3	On	On	Off
4	Off	Off	On
5	On	Off	On
6	Off	On	On

200MB SCSI Disk Drive

The 200MB SCSI disk drive is a 3-1/2 inch device which fits into a half-high media position.

Setting the SCSI Address

Notes:

1. The device is shipped with jumpers configured for Address 6.
2. All three terminating resistors must be removed before installing the drive.
3. All option jumpers must be removed.

The address/optional jumper block J4 is located on the fixed-disk logic card shown. Valid addressing information is given in the table below.

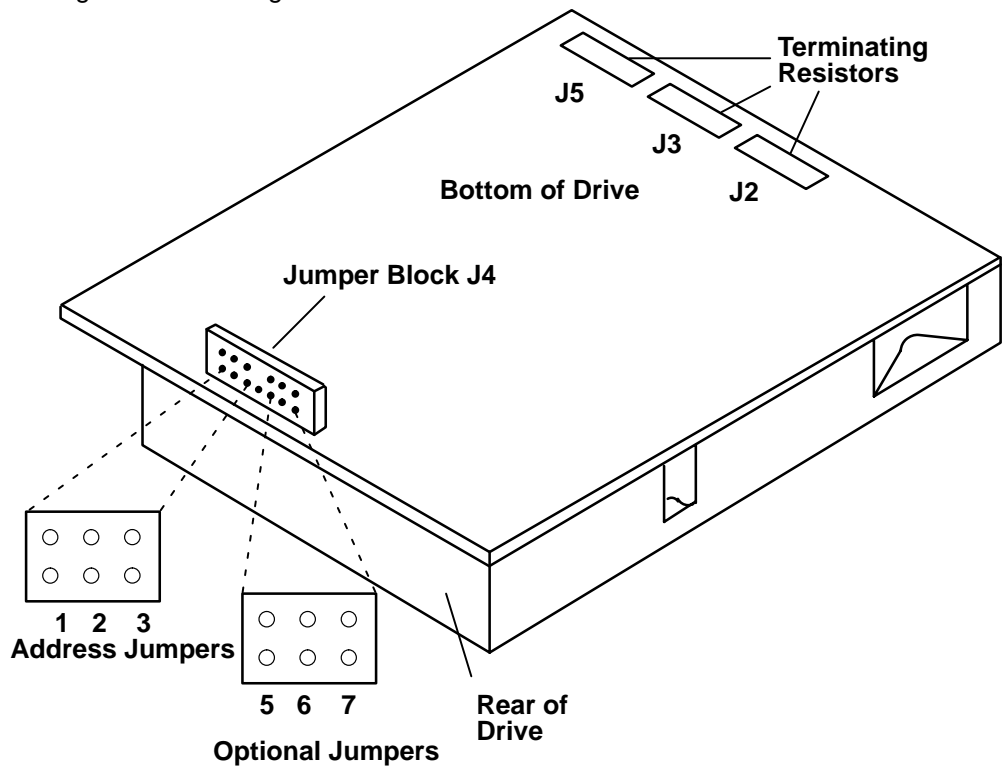

Valid Addresses

Address	Jumper 1	Jumper 2	Jumper 3
0	Off	Off	Off
1	On	Off	Off
2	Off	On	Off
3	On	On	Off
4	Off	Off	On
5	On	Off	On
6	Off	On	On

320MB and 400MB SCSI Disk Drives

The 320MB and 400MB SCSI disk drives are 3-1/2 inch devices each of which fits into a half-high media position.

Setting the SCSI Address

Note: The device is shipped with no jumpers installed.

Use the following diagram to locate the jumpers and set the SCSI address.

When the 320MB or 400MB SCSI disk drive is installed in the 7204, all jumpers must be removed and an address cable is attached to the connector. The SCSI address is set on the back panel of the device.

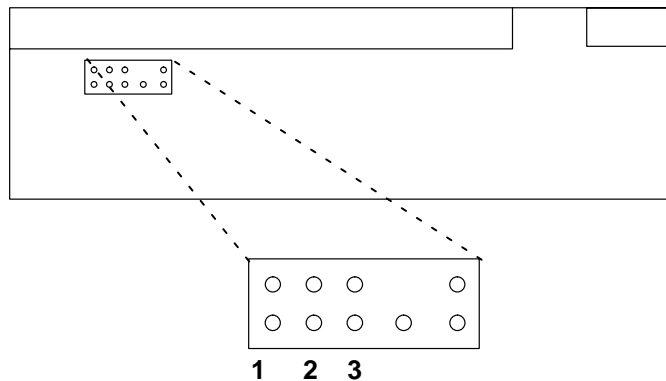

Valid Addresses

Address	Jumper 1	Jumper 2	Jumper 3
0	Off	Off	Off
1	On	Off	Off
2	Off	On	Off
3	On	On	Off
4	Off	Off	On
5	On	Off	On
6	Off	On	On

Exchanging the Logic Card and Frame Assembly

Refer to the procedures that were packed with the FRU.

355MB and 670MB SCSI Disk Drives

The 355MB and 670MB SCSI disk drives are 5-1/4 inch drives. These drives mount into a full-high media position.

Setting the SCSI Address Jumpers

Note: The device is shipped with no address jumpers installed. The number and settings of the other jumpers may vary and should not be changed.

The SCSI address of the 355MB and 670MB disk drives is set by jumpers located on the logic card. Use the following diagram to set the jumpers. When the drives are used in the modules for the 7203, the jumpers must be set to address 0.

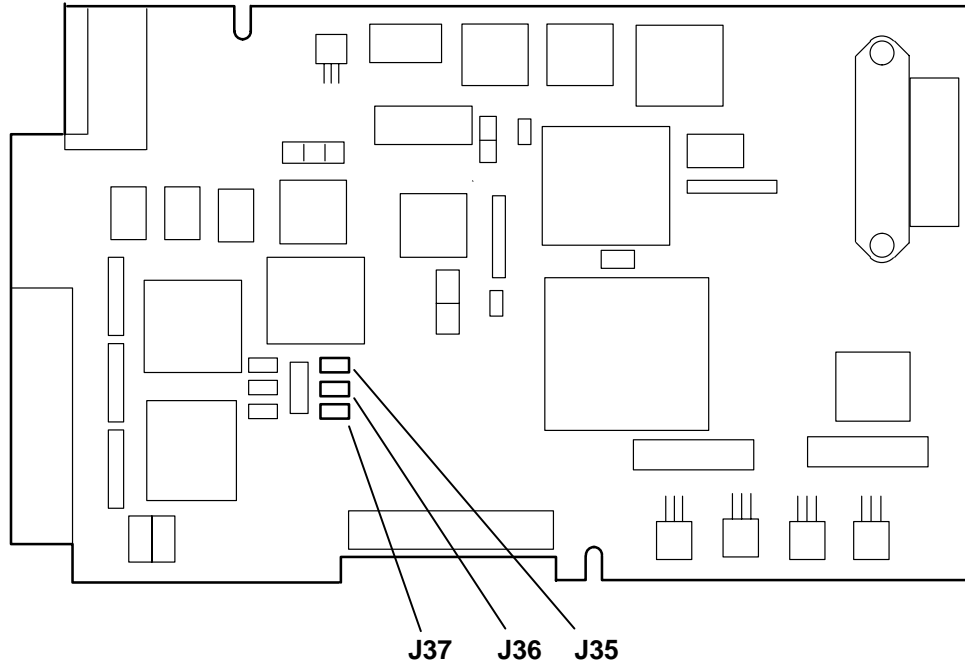

Valid Addresses

Address	Jumper 35	Jumper 36	Jumper 37
0	Off	Off	Off
1	On	Off	Off
2	Off	On	Off
3	On	On	Off
4	Off	Off	On
5	On	Off	On
6	Off	On	On

Exchanging the Logic Card

The logic card on the 355MB and 670MB disk drives can be removed without removing the disk enclosure. Use the following procedure to exchange the logic card:

1. Remove the disk drive (see the installation and service guide for the system unit or device).
2. Lay the drive upside down on a flat surface.
3. Record the setting of the SCSI address jumpers.
4. Remove the two screws that attach the rear brace to the frame on the J4 side of the drive.
5. Remove the four screws holding the logic card to the frame.
6. Carefully remove the Teflon tape from connectors J4 and J5 (save the tape).
7. Lift the logic card slightly and disconnect the cables from the connectors at J5.
8. Lift the logic card slightly and disconnect the cable from connector J4.
9. Tilt the one side of the logic card up and spread the frame enough to allow the card to be removed.
10. Be sure the logic card shield is in place before starting to install the new logic board; then assemble in the reverse order.

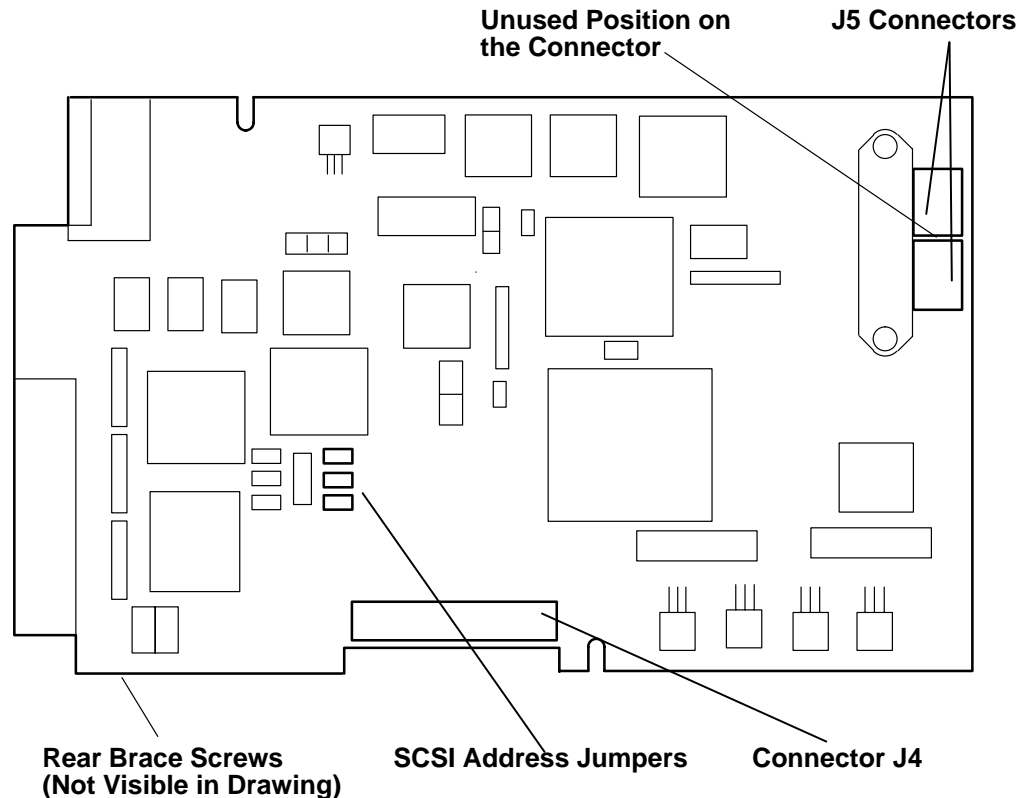

540MB SCSI-2 Single-Ended Disk Drive

The 540MB SCSI-2 disk drive has a 3.5 inch form factor and mount in a half-height media position.

Setting the SCSI Address Jumpers

Note: The device is shipped with jumpers configured for Address 6.

The SCSI address of the 540MB SCSI-2 disk drive is set by J6 jumpers located on the logic card. Use the following diagram to set the jumpers.

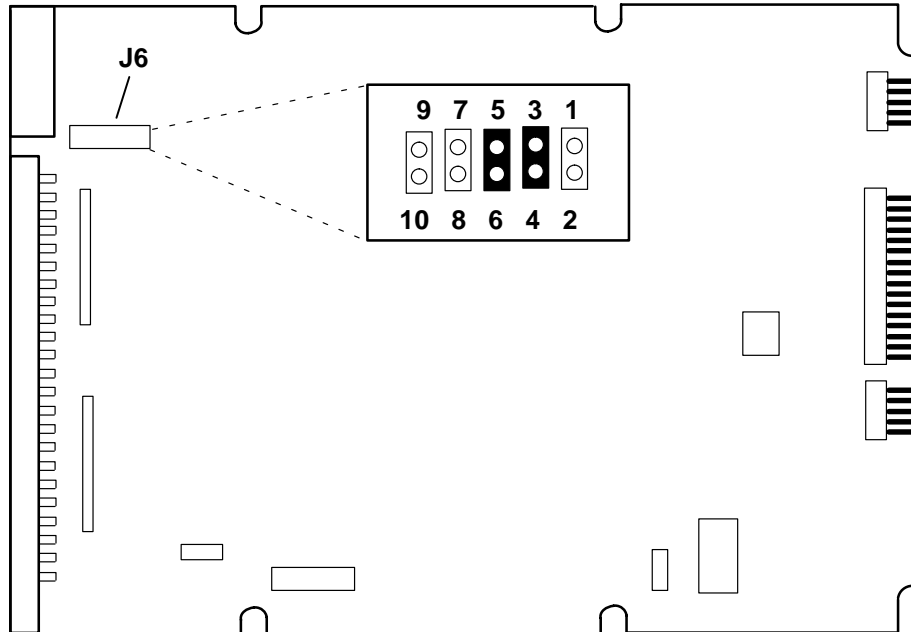

Valid Addresses

Address	Jumper 5-6	Jumper 3-4	Jumper 1-2
0	Off	Off	Off
1	Off	Off	On
2	Off	On	Off
3	Off	On	On
4	On	Off	Off
5	On	Off	On
6	On	On	Off

857MB SCSI Disk Drive

The 857MB SCSI disk drive is a 5-1/4 inch fixed-disk drive which mounts into a full-high media position.

Setting the SCSI Address Switches

The SCSI addresses of the 857MB SCSI disk drive is set with three switches on the rear of each drive. Use the following diagram to set the SCSI address.

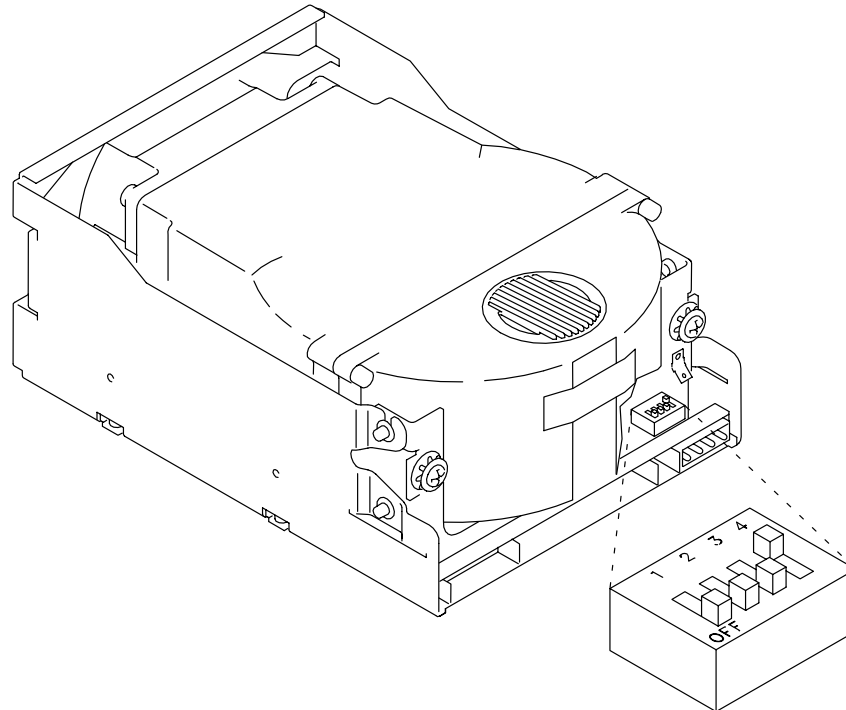

Valid Addresses

Note: The fourth switch is set to On.

Address	Switch 1	Switch 2	Switch 3
0	Off	Off	Off
1	Off	Off	On
2	Off	On	Off
3	Off	On	On
4	On	Off	Off
5	On	Off	On
6	On	On	Off

857MB Slim-High SCSI Single-Ended Disk Drive

The 857MB SCSI disk drive is a 3-1/2 inch fixed-disk drive which mounts into a full-high media position when mounted on its adapter plate.

857MB Slim-High Single-Ended Drive

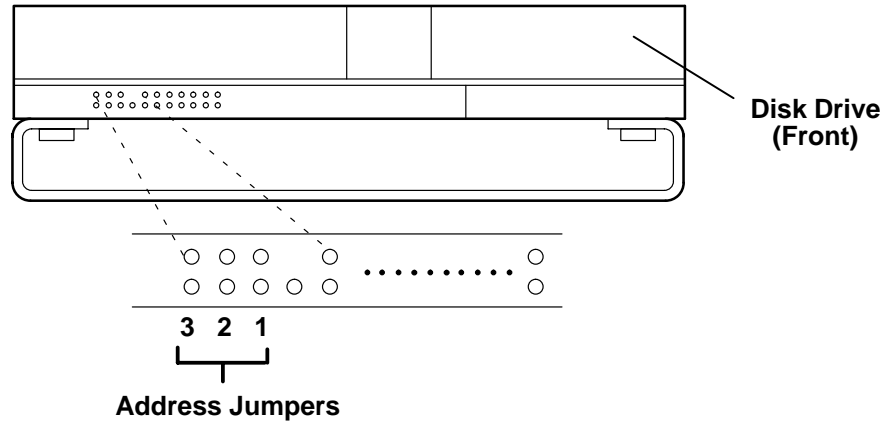

Note: This one-inch height drive is shipped with an appropriate mounting plate to increase its installed thickness.

Setting the SCSI Address Jumpers

Valid Addresses

Address	Jumper 1	Jumper 2	Jumper 3
0	Off	Off	Off
1	On	Off	Off
2	Off	On	Off
3	On	On	Off
4	Off	Off	On
5	On	Off	On
6	Off	On	On

Exchanging the Frame Electronics

Refer to the procedures that were packed with the FRU.

Logic Card Removal and Replacement Procedures

The 857M-byte SCSI disk drive does not come as one complete assembly. You must exchange either the disk enclosure or the logic card and frame assembly. The logic card and frame assembly is one Field Replaceable Unit (FRU). When you exchange the logic card and frame assembly, be sure to set the switches correctly. If the logic card and

frame assembly FRU does not fix your problem, install a new disk enclosure in the old logic card and frame assembly.

This same procedure is also used to exchange the disk enclosure.

Carefully perform the following procedure while observing the accompanying attention notices.

Attention:

- The disk drive weighs 3.5 kg (7.7 pounds). Take care when you remove it from the using system.
- When the disk drive is brought from an environment whose temperature is outside the specified operating range, that disk drive should not be used for at least three hours. This delay allows it to acclimatize to its new environment. During this period, the disk drive should be removed from its shipping box, but must remain in the sealed bag to prevent condensation from forming.
- The disk drives are fragile. Handle them with care and keep them well away from strong magnetic influences. Use protective packaging materials when transporting disk drives.
- The logic card is electrostatic discharge (ESD) sensitive. When handling the card, use the field ESD kit (part 6428316) in accordance with CEM 270 (305).
- A new FRU may not be compatible with the original FRU. If the instructions accompanying the new FRU indicate that the FRUs are compatible, continue with the procedures in this section. If the FRUs are not compatible, follow the instructions enclosed with the new FRU.

Note: Early logic card and frame assemblies (part 95X2172) are not inscribed or labeled with the part number. Later assemblies (part 95X2346) contain a part number label on the inside of the frame.

Disassembling the Disk Drive

1. Ensure that you have a flat work surface on which to disassemble the disk drive.
2. Switch off the using system.

Attention: Allow approximately 20 seconds for the disk drive to stop rotating. Do not attempt to remove the disk drive until it has stopped rotating.

3. Remove the disk drive (see the installation and service guide for the system unit or device).
4. Lay the disk drive onto a suitable support [1]. The support must be narrower than the disk enclosure [2], so that it does not touch the frame [3] of the logic card assembly, and thick enough (approximately 7 mm or 0.25 inches) to hold the frame just clear of the work surface. A notepad or similar item makes an ideal support.

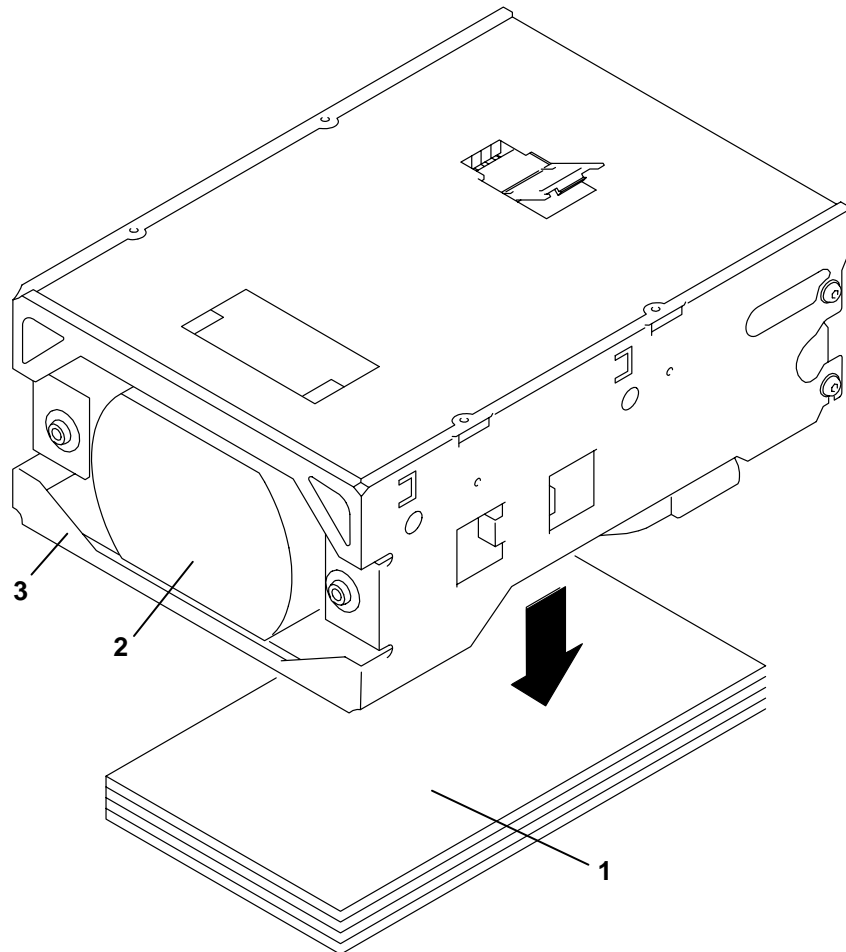

Attention: In this step and the following steps, you are going to disconnect the spindle-motor connector. The wires to this connector might become damaged if they are pulled or bent too much. Follow the instructions carefully.

5. Using a small screwdriver, release and carefully lift the plastic flap of the spindle-motor connector [1].
6. Slide the connector in the direction of the arrow, and disconnect it from the logic card.

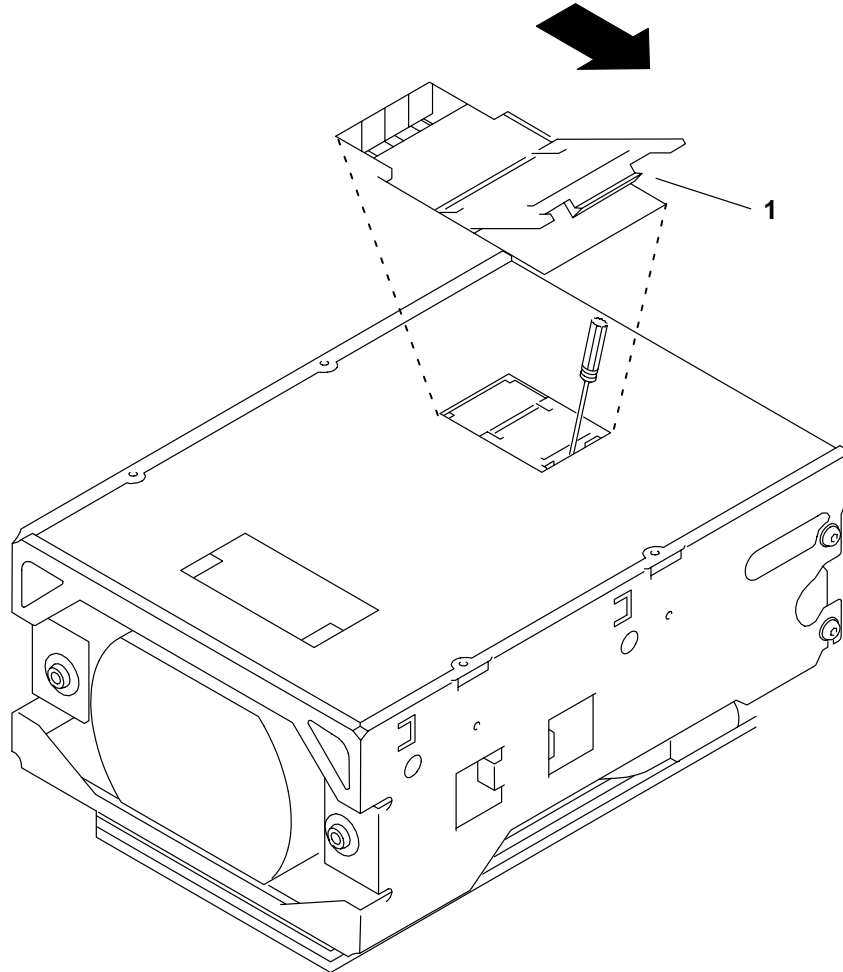

7. Lift the paper flap [1].
8. Open the retaining bar [2] by pulling it back to the position shown in the diagram.
9. Using two ball-point pens or similar objects in the holes of the flexible circuit [3], pull the flexible circuit out from the connector (in the direction shown by the arrow). *Do not try to pull the flexible circuit out from under the logic card.*

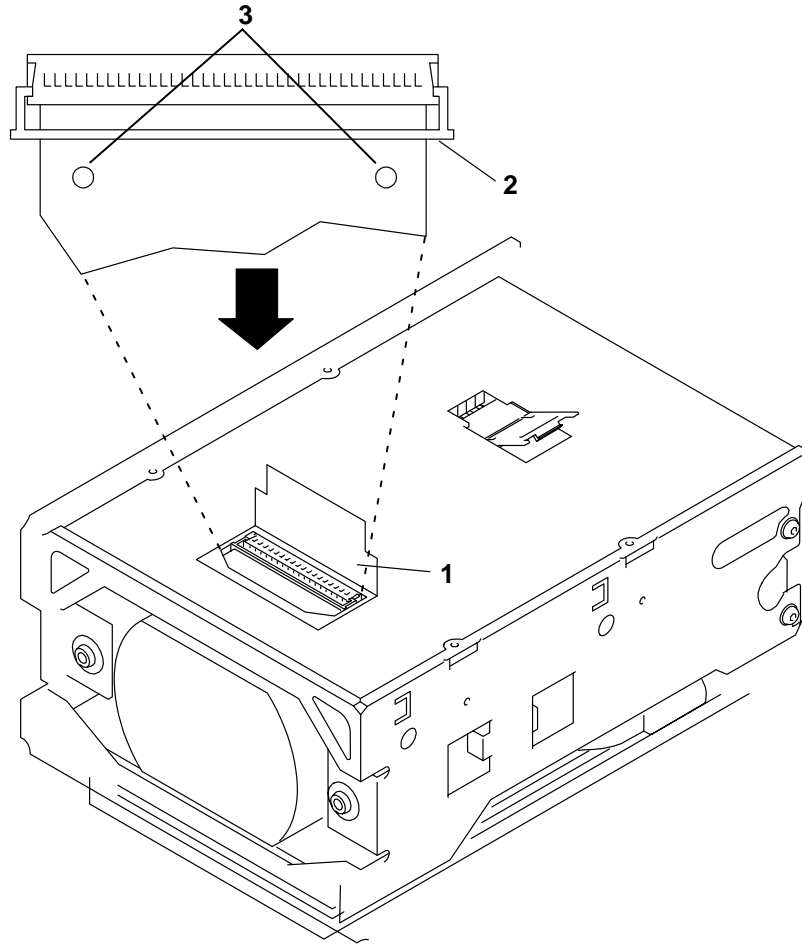

10. Close the retaining bar [2] to prevent the flexible circuit from reentering the connector.
11. Loosen the four cross-member screws [2] (part number 95X1939).
12. Remove the four disk-enclosure mounting screws [1] (part number 95X1940).

Note: Some shock mounts [7] (part number 95X1995) have separate bushings [4] (part number 95X2191). These bushings might fall out when you remove the screws. Do not lose them.

13. Carefully start to lift the logic card and frame assembly [3] away from the disk enclosure. As you lift the assembly, carefully push the spindle motor connector [8] down through the hole in the logic card. Keep the connector end [5] of the assembly slightly higher than the actuator end [6] while you are lifting, so that the cross member passes over the end of the disk enclosure.

Note: You might feel some friction when lifting the logic card and frame assembly.

Attention: Do not attempt to remove the logic card from the frame assembly; damage to the card could occur. The logic card and frame assembly are exchanged together as a single FRU.

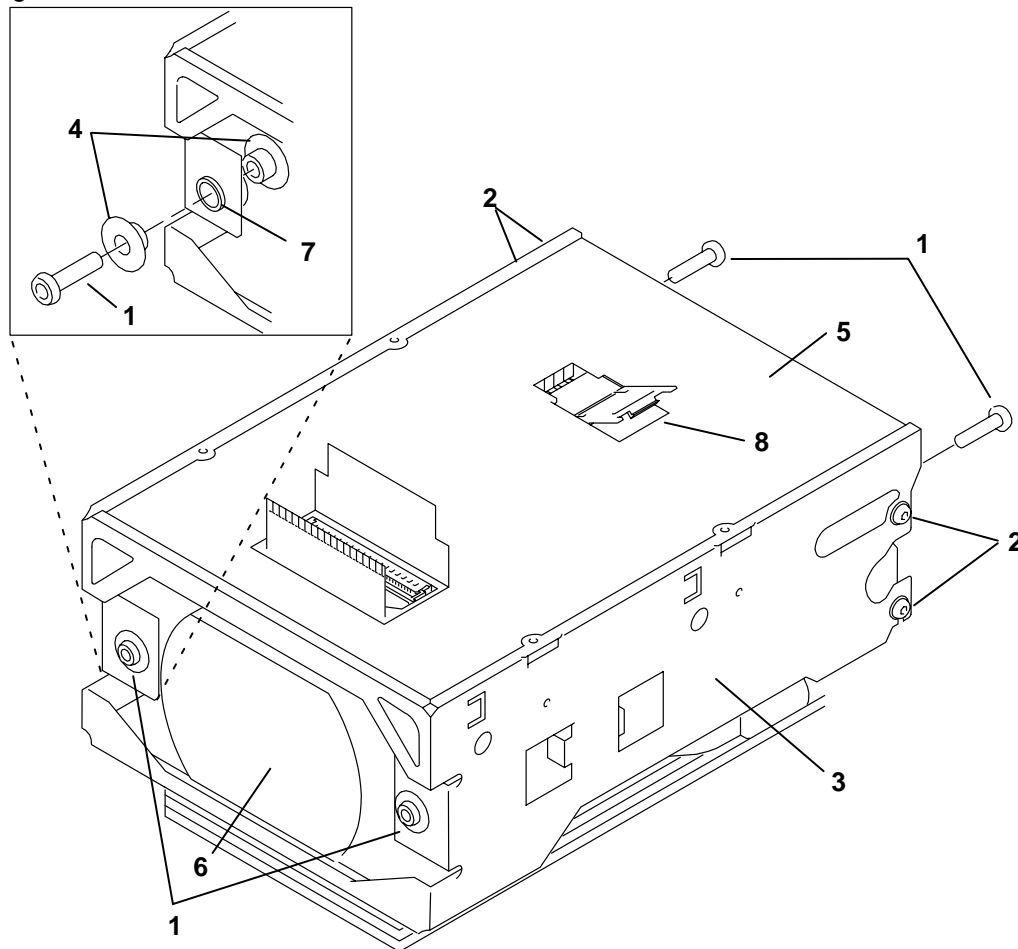

Assembling the Disk Drive

Attention: A replacement disk enclosure might need time to acclimatize to its new environment. See the Attention notices at the first of the removal and replacement procedures.

1. Ensure that you have a flat work surface on which to assemble the disk drive.
2. Lay the disk enclosure onto a suitable support. The support must be narrower than the disk enclosure, so that it does not touch the frame when the logic card assembly is installed, and thick enough (approximately 7 mm or 0.25 inches) to hold the frame just clear of the work surface. A notepad or similar item makes an ideal support. Ensure that the actuator-end [1] of the disk enclosure protrudes beyond the edge of the support.

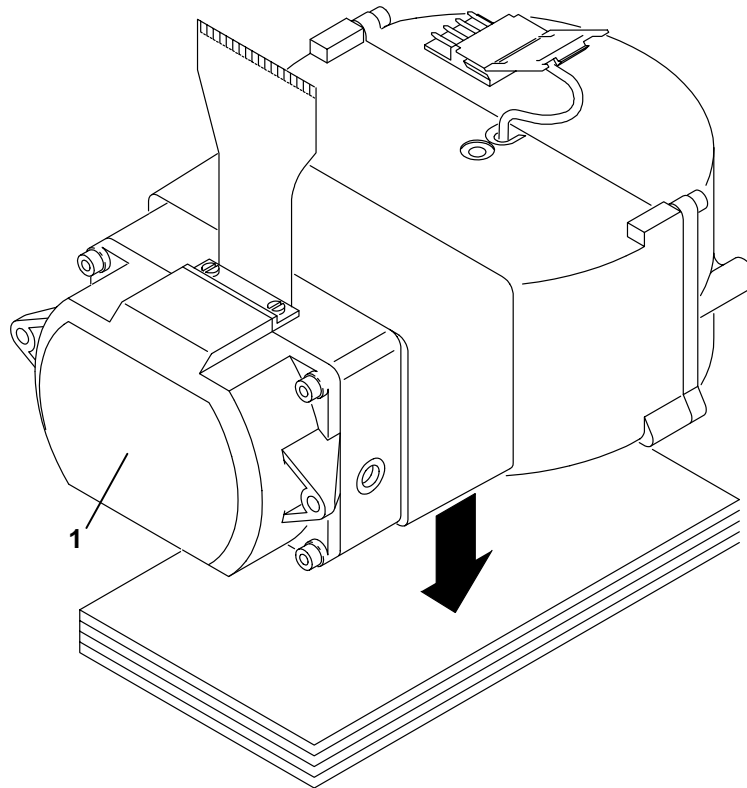

3. Fold the flexible circuit as shown below. Ensure that:

- The first fold [1] is at the point where the flexible circuit enters the disk enclosure.
- The second fold [2] is in line with the actuator end of the disk enclosure.

Make two creases in the flexible circuit by pressing on the folds. These creases help to locate the flexible circuit correctly when the disk drive is assembled.

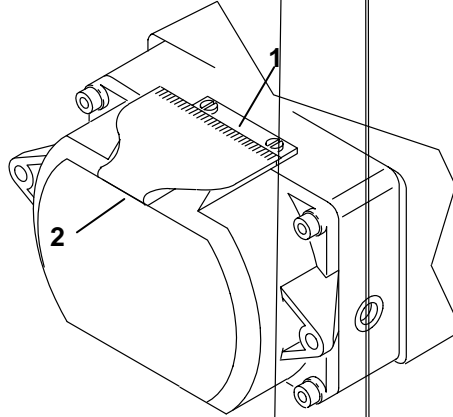

4. If you are exchanging the logic card and frame assembly, configure the four switches [2] on the replacement logic card and frame assembly to match that of the replaced FRU.

Attention: Missing or additional terminator blocks can cause intermittent problems. Ensure that the terminator block [1] configuration of the replacement logic card and frame assembly is the same as that of the replaced FRU. For most systems, the terminator block must be removed.

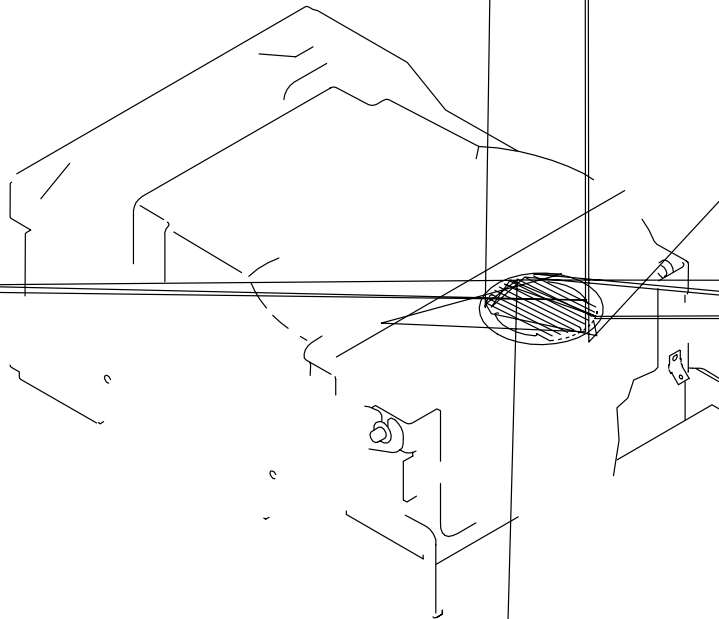

5. Ensure that the four screws [1] in the front cross-member are loose.
6. Open the retaining bar [2] by pulling it back to the position shown in the diagram.

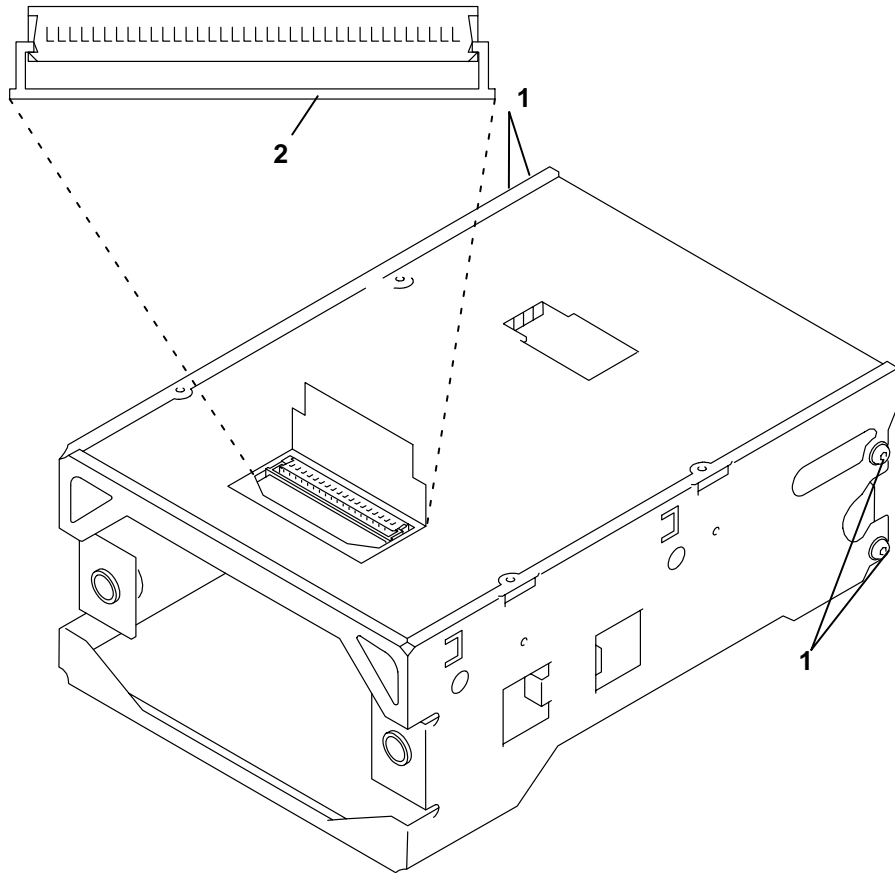

7. If the shock mounts have separate bushings, ensure that those bushings [1] are present in all four shock mounts.

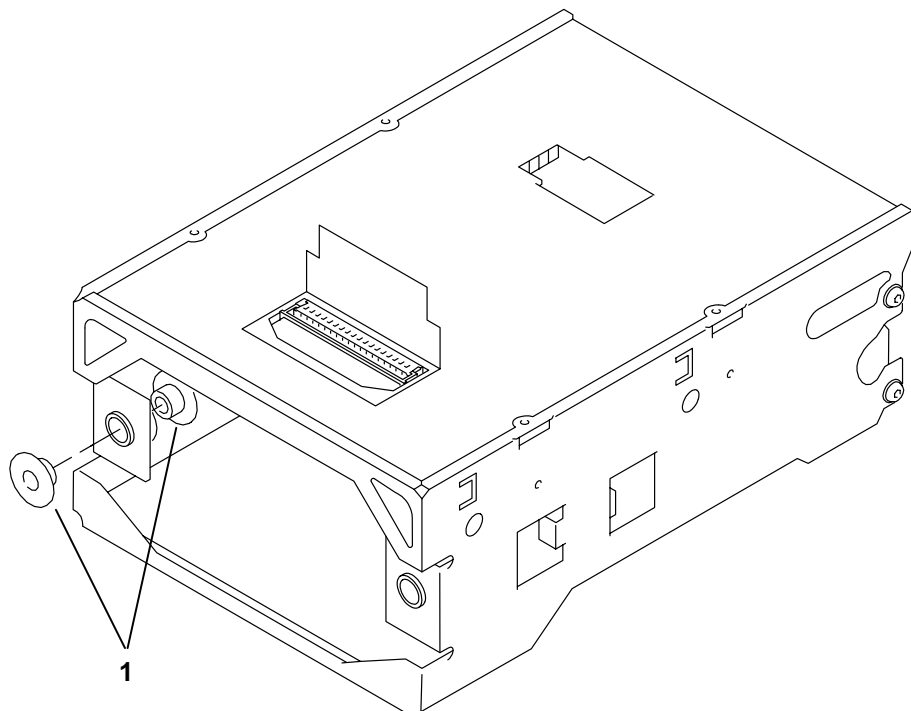

8. Holding the connector end [3] of the frame slightly higher than the actuator end [4], lower the frame over the disk enclosure, and guide the flexible circuit [1] into the actuator connector [2], *but do not close the retaining bar yet.*

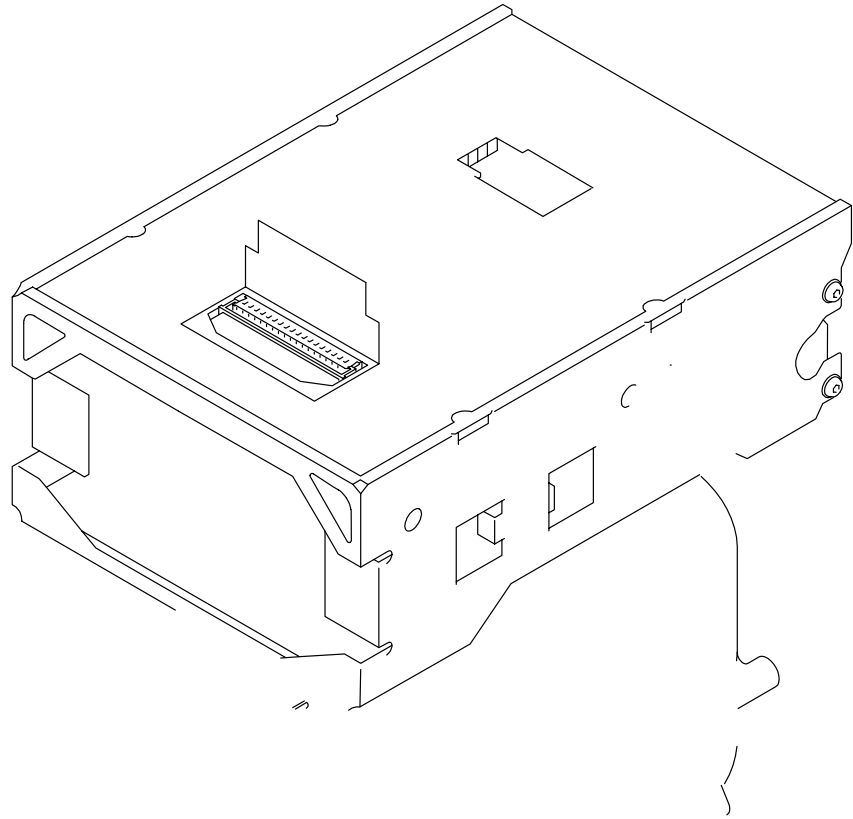

Attention: The wires on the spindle-motor connector [1] might become damaged if they are pulled or bent too much. Handle them with care.

9. Lower the frame, and carefully guide the spindle-motor connector [1] up through the hole in the logic card. Ensure that the flexible circuit folds correctly. Continue lowering the frame until it rests on the disk enclosure.

Note: Although resting on the disk enclosure, the frame is not steady. This effect is normal.

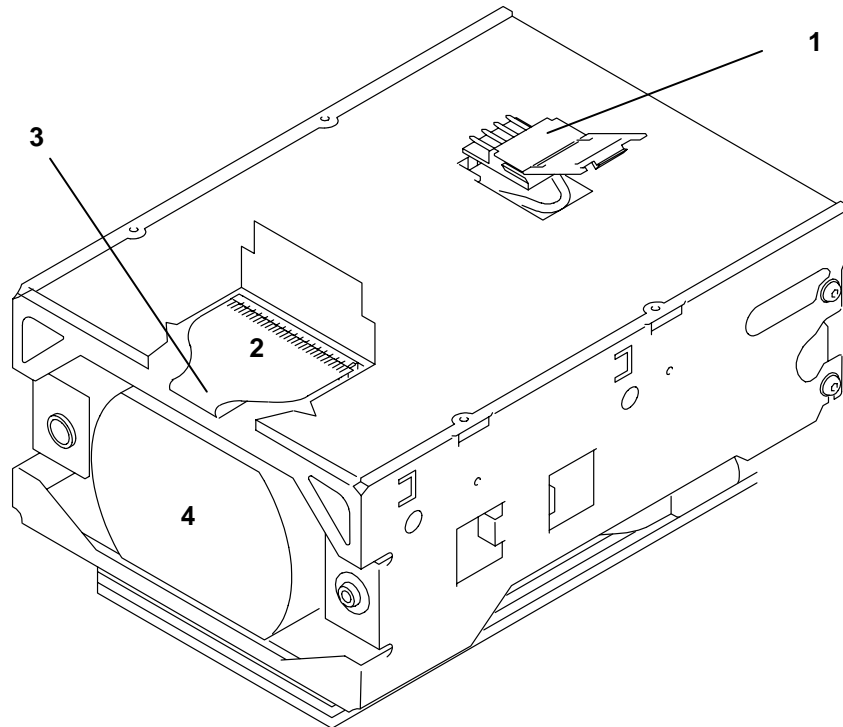

10. Check that the flexible circuit [2] is still located correctly. The second fold [3] should be just visible at the actuator end [4] of the disk enclosure.
11. If the shock mounts [5] (part number 95X1995) have separate bushings [1] (part number 95X2191), ensure that all those bushings are still present.
12. At the *actuator-end* of the disk drive, install and fully tighten the two disk-enclosure mounting screws [2] (part number 95X1940).
13. At the *connector-end* of the disk drive, install and fully tighten the two disk-enclosure mounting screws [3]. Do not press down on the disk drive as you do this.
14. Fully tighten the four crossmember screws [4].

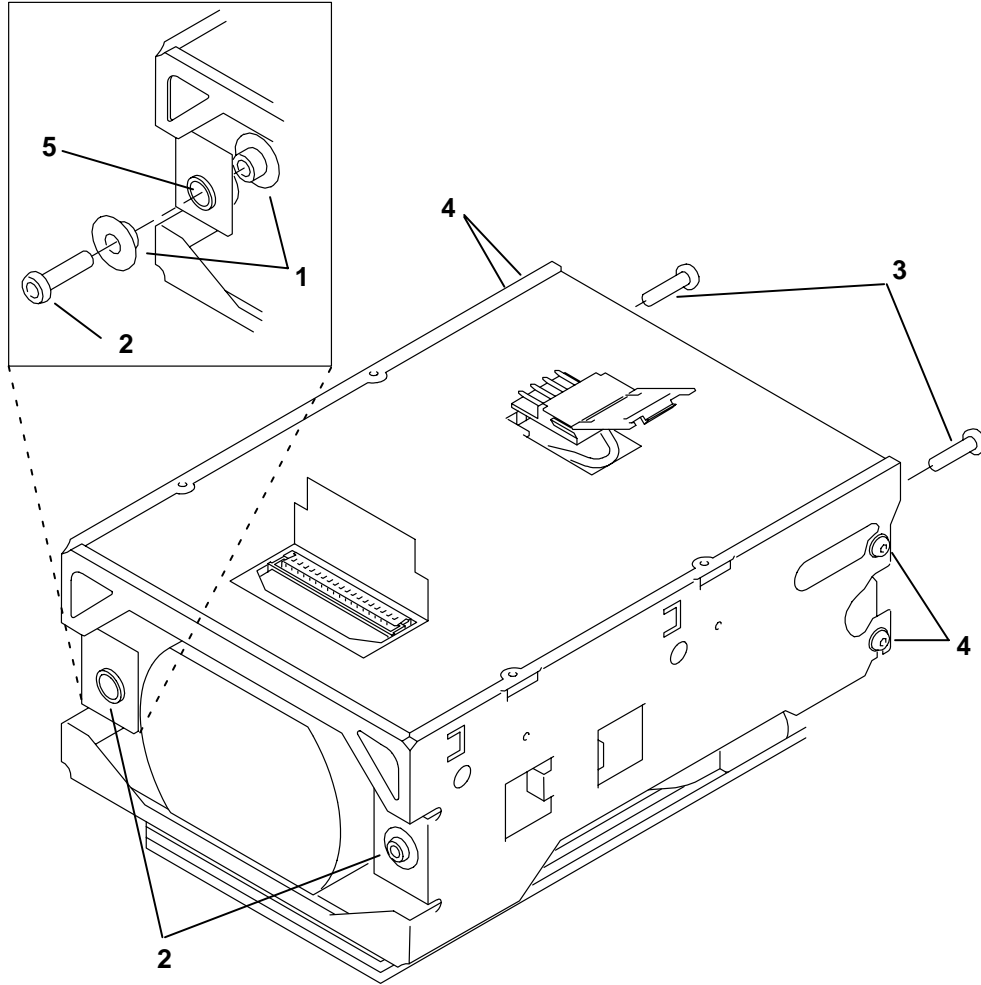

Attention: If the front cross-member is not aligned correctly, the disk drive might become damaged through excessive vibration.

15. Check that the front-cross member [1] is correctly aligned. Check also that the clip [3] at each end of the crossmember is not trapped behind the connector. If necessary, loosen the four crossmember screws [2], relocate the cross-member, and then tighten the screws.

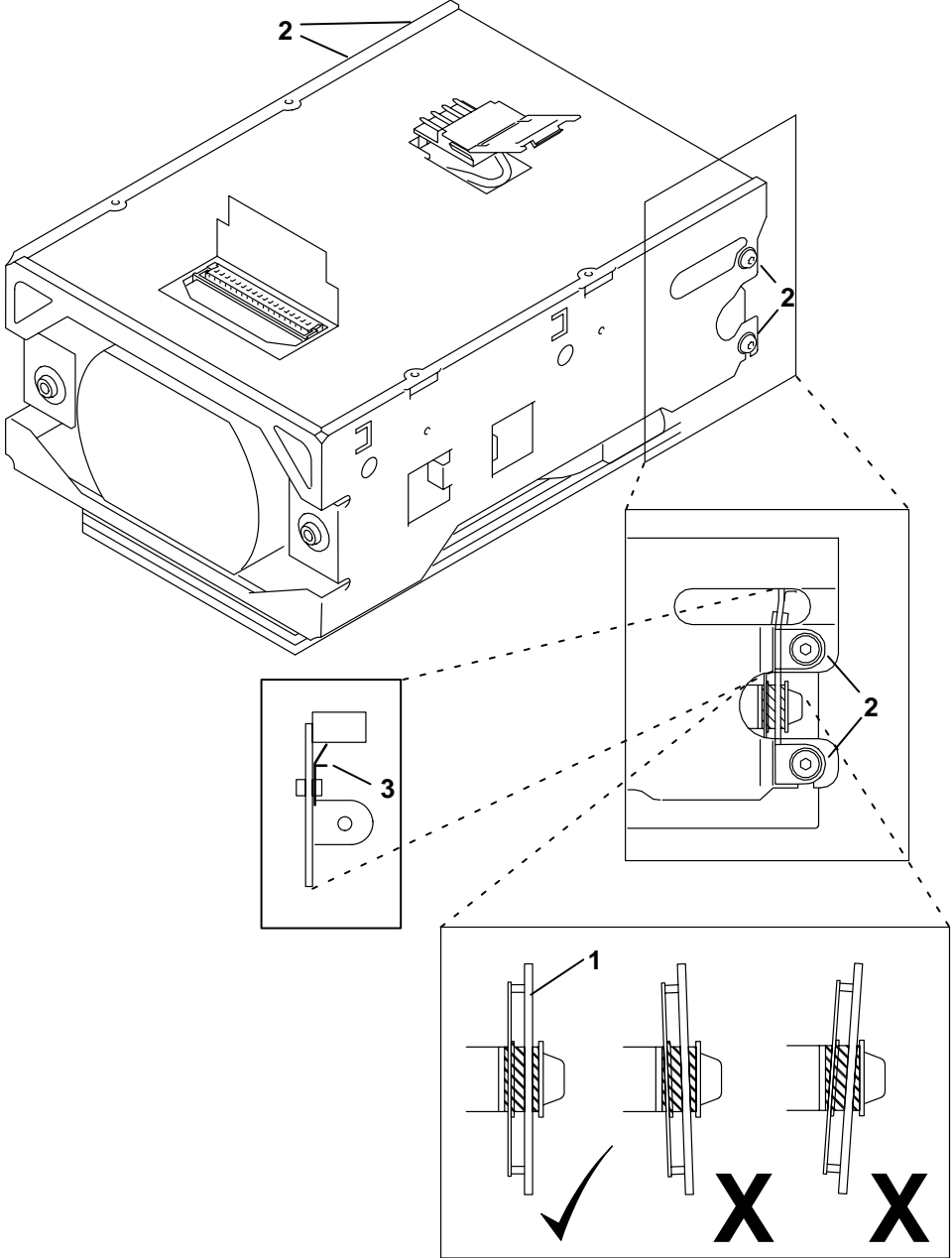

16. Engage the grooves of the spindle-motor connector [1] with the edges of the hole in the logic card. Ensure that the connector pins are correctly aligned, and then push the connector fully home.
17. **Attention:** The wires on the spindle-motor connector might become damaged if they rub against a component or the edge of the logic card.

Bend the wires [3] as shown.

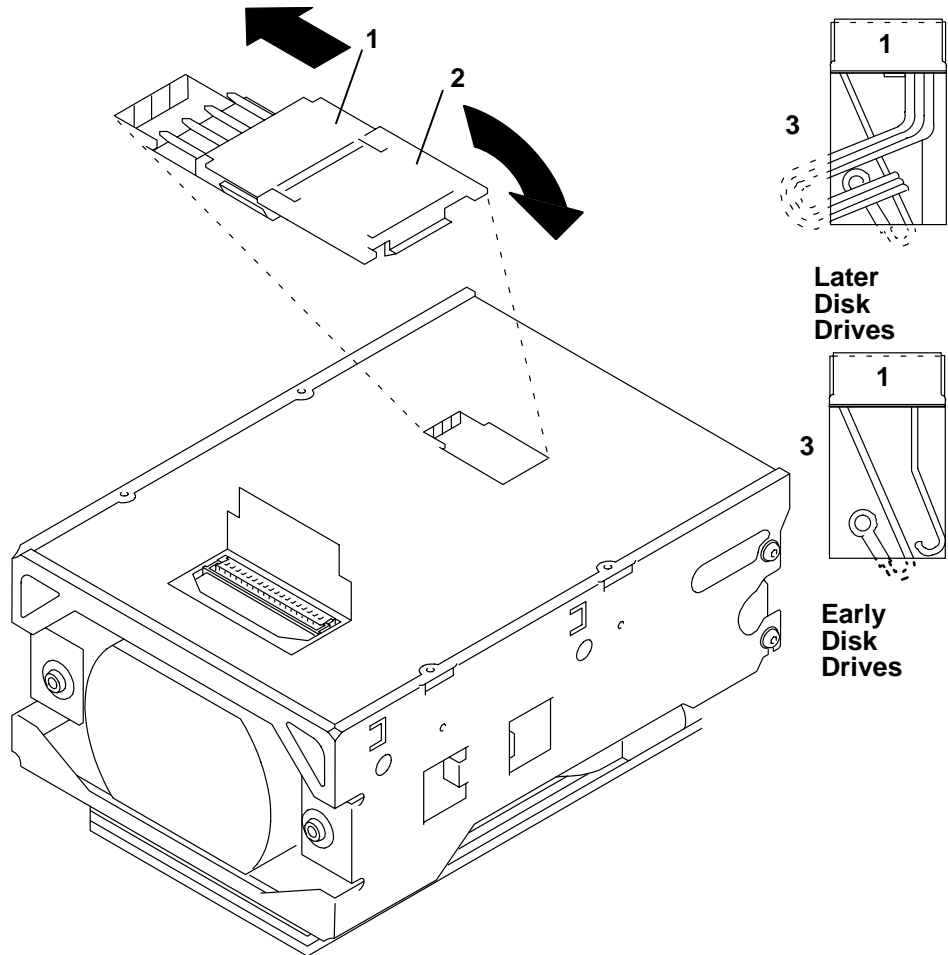

18. Close the plastic flap [2] and press it firmly until it clicks into position.
 19. Using two ball-point pens or similar instruments in the holes of the flexible circuit [3], ensure that the flexible circuit is pushed fully home. The top edge of the label [2] should be just below the open retaining bar [1] when the flexible circuit is in its correct position.
- Note:** On early disk drives, the label is not present. Use the thin line [2] on the flexible circuit instead. This line corresponds to the top edge of the label.
20. Close the retaining bar. (The illustration below also shows the retaining bar in the closed position.)

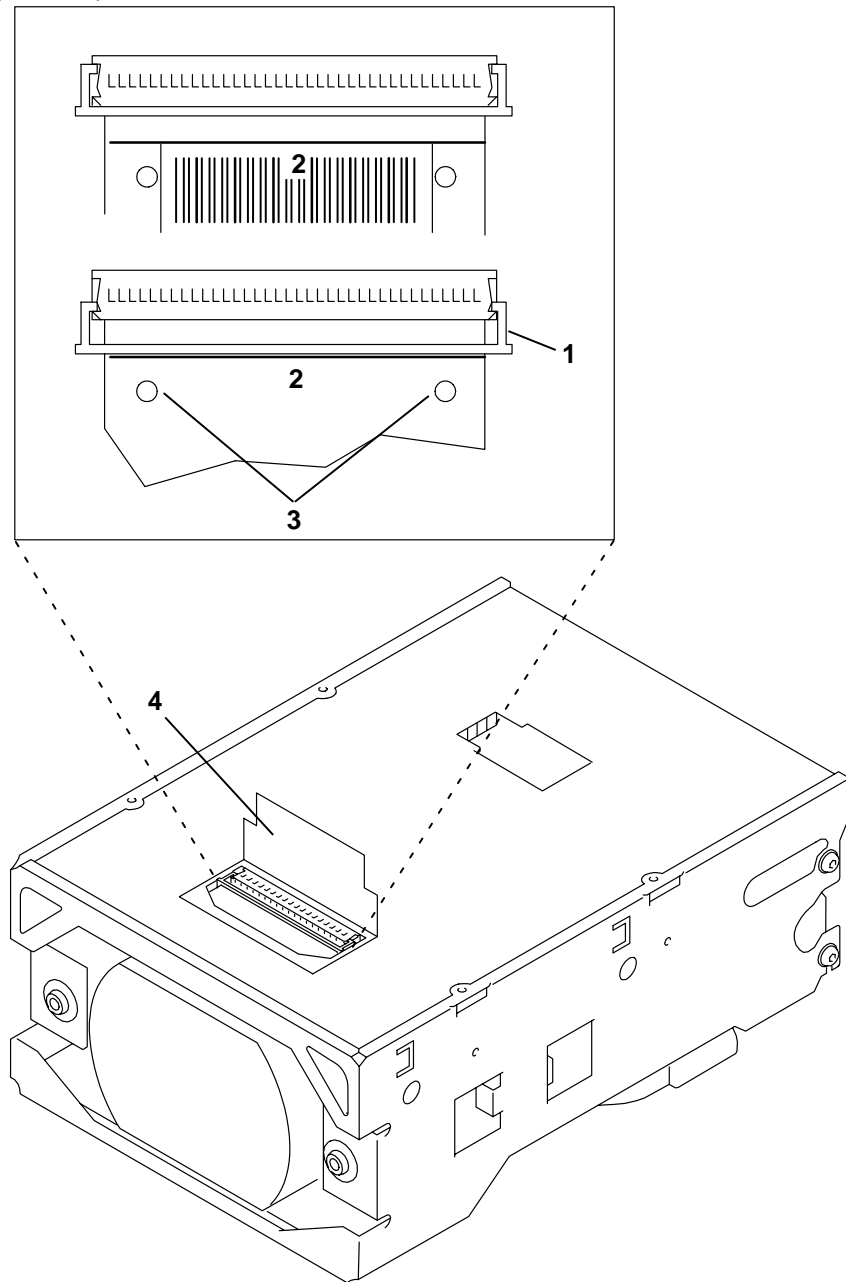

21. Close the paper flap [4]. Locate the excess flap under the edge of the slot in the logic card.
22. Check that all screws are tight.
23. Reinstall the disk drive in the using system.

1G-byte SCSI Single-Ended and Differential Disk Drives

The 1G-byte SCSI disk drives are 3-1/2 inch devices which fit into half-high media positions.

Setting the SCSI Address

Use the illustrations on this and following pages to locate the jumpers and set the SCSI address.

Note: The devices are shipped with no jumpers installed. When a 1G-byte SCSI disk drive is installed in the 7204, all jumpers must be removed, and an address cable is attached to the connector. The SCSI address is set on the back panel of the device.

Half-High Single-Ended Drives

1 G-byte half-high single-ended drives may be either of the following configurations.

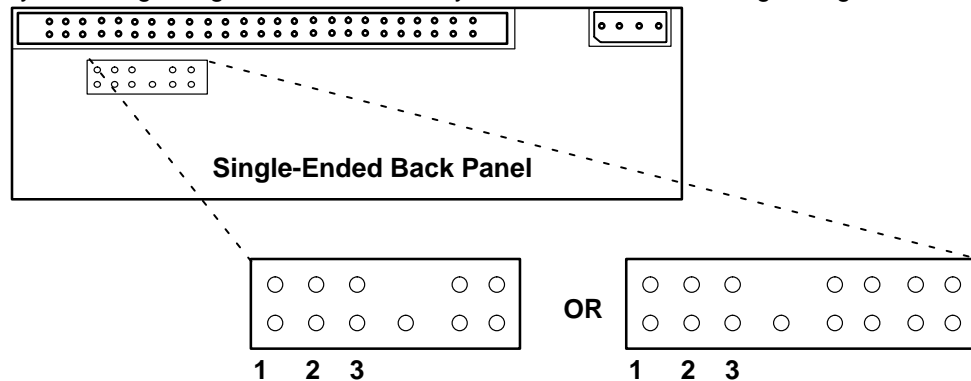

Valid Addresses

Address	Jumper 1	Jumper 2	Jumper 3
0	Off	Off	Off
1	On	Off	Off
2	Off	On	Off
3	On	On	Off
4	Off	Off	On
5	On	Off	On
6	Off	On	On

Exchanging the Frame Electronics

Refer to the procedures that were packed with the FRU.

Slim-High Single-Ended Drives

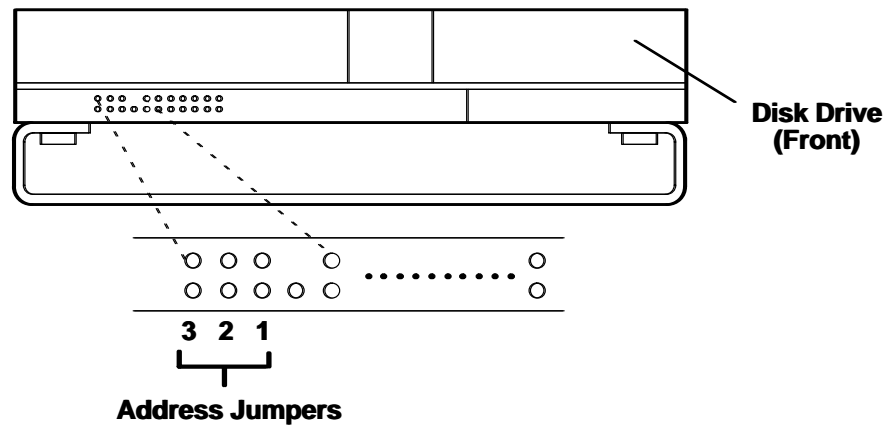

Note: This one-inch height drive is shipped with an appropriate mounting plate to increase its installed thickness.

Valid Addresses

Address	Jumper 1	Jumper 2	Jumper 3
0	Off	Off	Off
1	On	Off	Off
2	Off	On	Off
3	On	On	Off
4	Off	Off	On
5	On	Off	On
6	Off	On	On

Exchanging the Frame Electronics

Refer to the procedures that were packed with the FRU.

Half-High Differential Drives

Note: The differential drive signal connector is labelled "Differential SCSI."

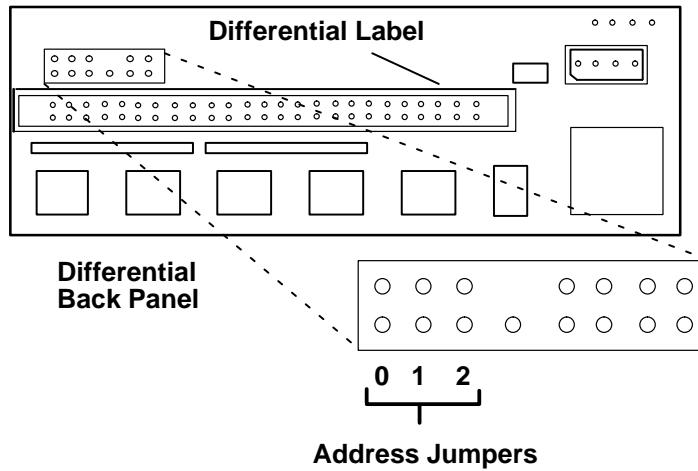

Valid Addresses

Address	Jumper 1	Jumper 2	Jumper 3
0	Off	Off	Off
1	On	Off	Off
2	Off	On	Off
3	On	On	Off
4	Off	Off	On
5	On	Off	On
6	Off	On	On

Exchanging the Frame Electronics

Refer to the procedures that were packed with the FRU.

1080MB SCSI-2 Disk Drive

The 1080MB SCSI-2 disk drive has a 3.5 inch form factor and mounts in a half-height media position.

Setting the SCSI Address Jumpers

Note: The device is shown with jumpers configured for SCSI Address 6.

The SCSI address of the 1080MB SCSI-2 disk drive is set by jumpers located on the logic card. Use the following diagram to set the jumpers.

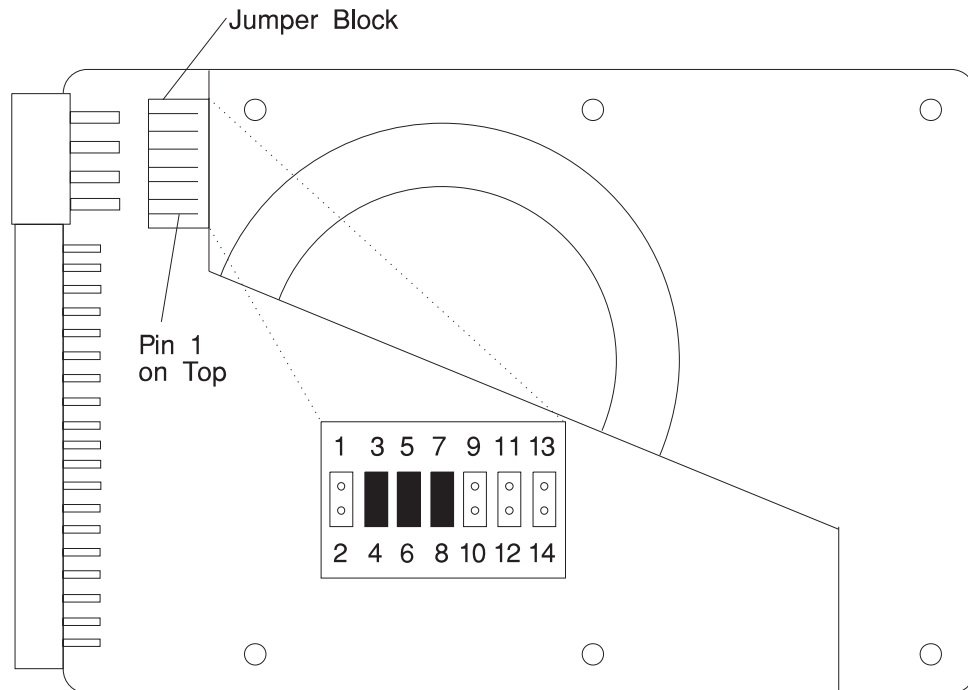

Valid Addresses

Address	Jumper 1-2	Jumper 3-4	Jumper 5-6
0	Off	Off	Off
1	On	Off	Off
2	Off	On	Off
3	On	On	Off
4	Off	Off	On
5	On	Off	On
6	Off	On	On

2.1GB SCSI-2 Disk Drive

The 2.1GB SCSI-2 disk drive has a 3.5 inch form factor and mounts in a half-height media position.

Setting the SCSI Address Jumpers

Note: The device is shown with jumpers configured for SCSI Address 6.

The SCSI address of the 2.1GB SCSI-2 disk drive is set by jumpers located on the logic card. Use the following diagram and the SCSI address table on page 2-75 to set the jumpers.

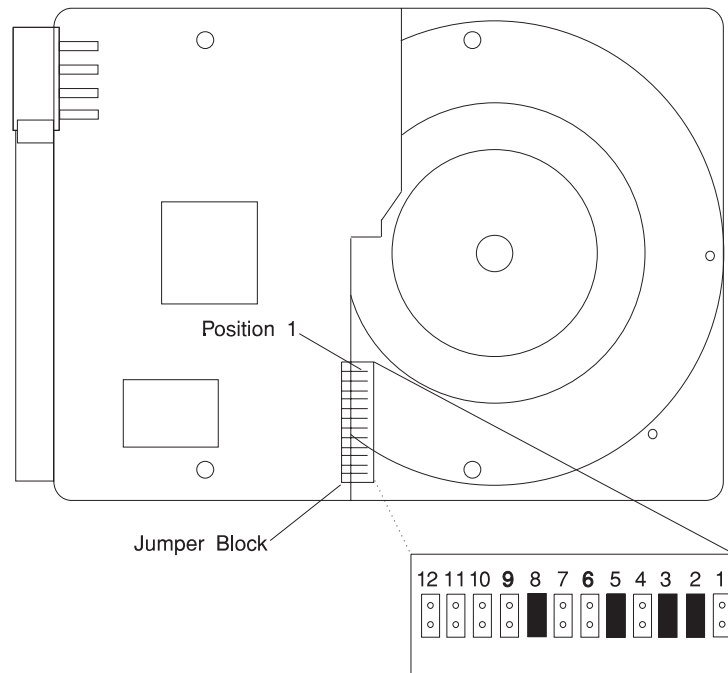

- Positions 5, and 8 must have jumpers.
- Positions 1, 6, 7, 9, 10, 11, and 12 must not have jumpers.

4.5GB SCSI-2 Disk Drive - Type F1

The 4.5GB SCSI-2 disk drive has a 3.5 inch form factor and mounts in a half-height media position. See table in section "1.1GB, 2.2GB, 4.5GB, 9.1GB, (50 and 68-pin) Single-Ended Disk Drives" on page 2-76 for description of disk drive Type - F1.

Setting the SCSI Address Jumpers

Note: The device is shown with jumpers configured for SCSI Address 6.

The SCSI address of the 4.5GB SCSI-2 disk drive is set by jumpers located on the logic card. Use the following diagram and the SCSI address table on page 2-75 to set the jumpers.

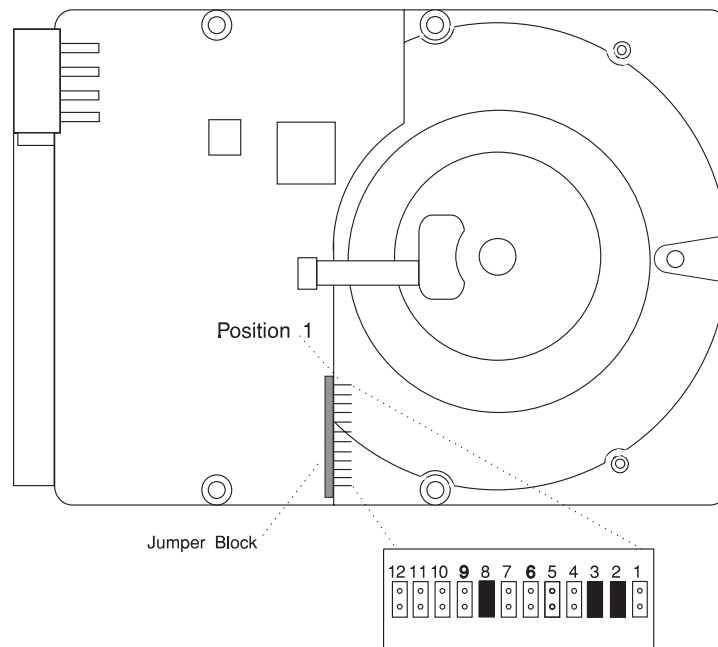

- Position 8 must have a jumper.
- Positions 5, 6, 7, 9, 10, 11, and 12 must not have jumpers.

SCSI Address Table

Address	Jumper 4	Jumper 3	Jumper 2	Jumper 1
0	Off	Off	Off	Off
1	On	Off	Off	Off
2	Off	On	Off	Off
3	On	On	Off	Off
4	Off	Off	On	Off
5	On	Off	On	Off
6	Off	On	On	Off
7	On	On	On	Off
8	Off	Off	Off	On
9	On	Off	Off	On
10	Off	On	Off	On
11	On	On	Off	On
12	Off	Off	On	On
13	On	Off	On	On
14	Off	On	On	On
15	On	On	On	On

Note:

1. Address 7 is reserved for the adapter.
2. There is no jumper 1 on 50 pin drives, thus SCSI addresses eight to fifteen are not valid.

1.1GB, 2.2GB, 4.5GB, 9.1GB, (50 and 68-pin) Single-Ended Disk Drives

There are many different types of the SCSI-2 Disk Drives. Before you can set the SCSI address, you must determine which type of SCSI-2 disk drive you have. The table below describes the various features of each drive to help you do this.

Type	Form Factor	Capacity in GB	SCSI Conn Pins	Required Jumper(s)	Jumper Block Pins	Drive Type
A1	1"	1.1/2.2	50-pin	23-24 ¹	32	DFHS/DFMS
A2	1"	1.1/2.2	68-pin	23-24 ¹	32	DFHS/DFMS
A3	1.6"	4.5	68-pin	23-24 ¹	32	DFHS/DFMS
A4	1"	2.2	68-pin ⁴	23-24 ¹ 25-26 ²	32	DFHS
B1	1"	1.1/2.2	50-pin	None	20	Quantum
B2	1"	1.1/2.2	68-pin	None	12	Quantum
B3	1.6"	4.5	68-pin	None	12	Quantum
C1	1"	2.2	50-pin	None	32	DCHS
C2	1"	2.2	68-pin	None	32	DCHS
C3	1"	4.5	68-pin	23-24 & 31-32 ²	32	DCHS
C4	1.6"	9.1	68-pin	23-24 & 31-32 ²	32	DCHS
C5	1"	2.2	68-pin ⁴	25-26 ²	32	DCHS
D1	1"	2.2/4.5	68-pin	31-32 ²	32	Quantum
D2	1.6"	9.1	68-pin	31-32 ²	32	Quantum
D3	1"	2.2	68-pin ⁴	23-24 & 31-32 ²	32	Quantum
E1	1"	9.1	68-pin	None	32	DGHS
F1	1"	4.5	68-pin	Note ³	-	DDRS

Notes:

¹Factory installed jumpers

²Customer or customer representative installed jumpers.

³See jumper setting information in "4.5GB SCSI-2 Disk Drive - Type F1" on page 2-74.

⁴This is a 68-pin drive being used as a 50-pin drive.

Other differences to look for are the number jumper block pins, and SCSI connector size.

SCSI-2 Disk Drives

The following figures show the location of the jumper blocks and where to place the jumpers to set the SCSI address or SCSI ID. There are three jumpers to set on 50-pin models and four on 68-pin models.

Setting the SCSI address or SCSI ID

To set the SCSI address or SCSI ID see the Valid Addresses (SCSI IDs) table on page 2-87.

Type A1 Drive

For 1.1GB, and 2.2GB drives, 50-pin models.

Note: Type A disk drives are shipped with one factory installed jumper. Do not change the factory installed jumper.

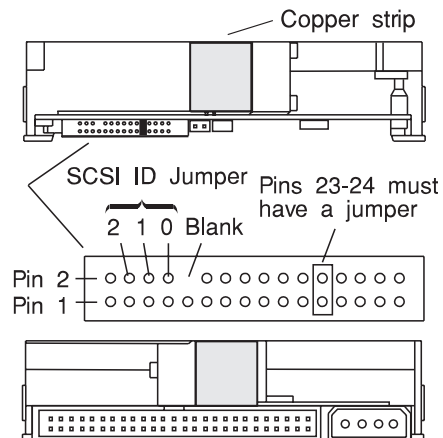

Type A2 Drive

For 1.1GB, and 2.2GB drives, 68-pin models.

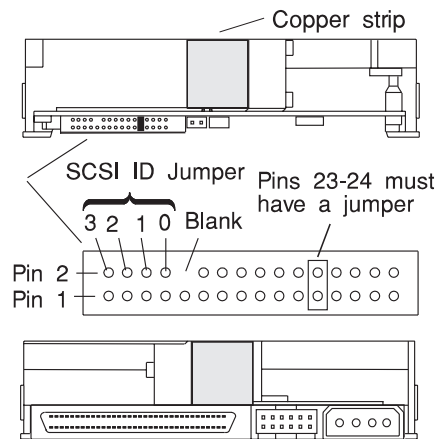

Type A3 Drive

For 4.5GB drives, 68-pin model.

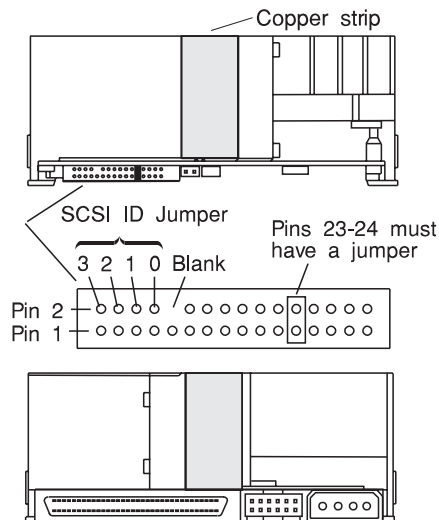

Type A4 Drive

The type A2 2.2GB, 68-pin (16-bit) disk drive can be used as a 50-pin (8-bit) drive by adding a jumper.

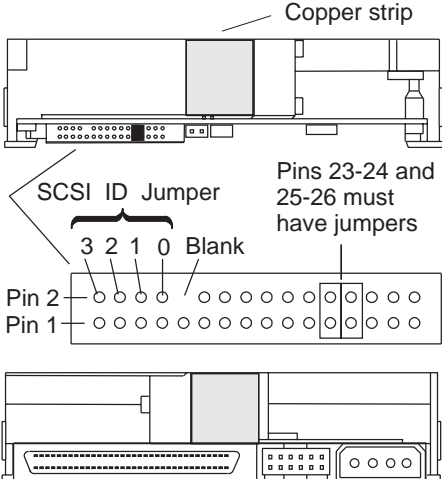

- Pins 23-24 and 25-26 must be jumpered together as shown in the figure above.
- Jumper 3 on pins 1 to 2 is not used in this configuration. Do not place a jumper on these pins. Eight bit devices can only use SCSI ID's zero (0) through six (6).
- Some systems require a 68-pin to 50-pin interposer, made up of a short cable and interposer as shown below.

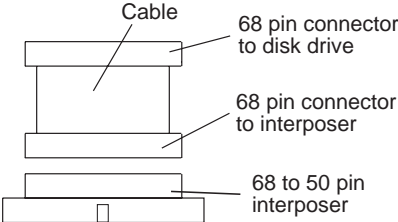

Type B1 Drive

For 1.1GB, and 2.2GB drives, 50-pin models.

Bright metal lid

SCSI ID Jumper

1 0 Blank

Pin

Pin 1

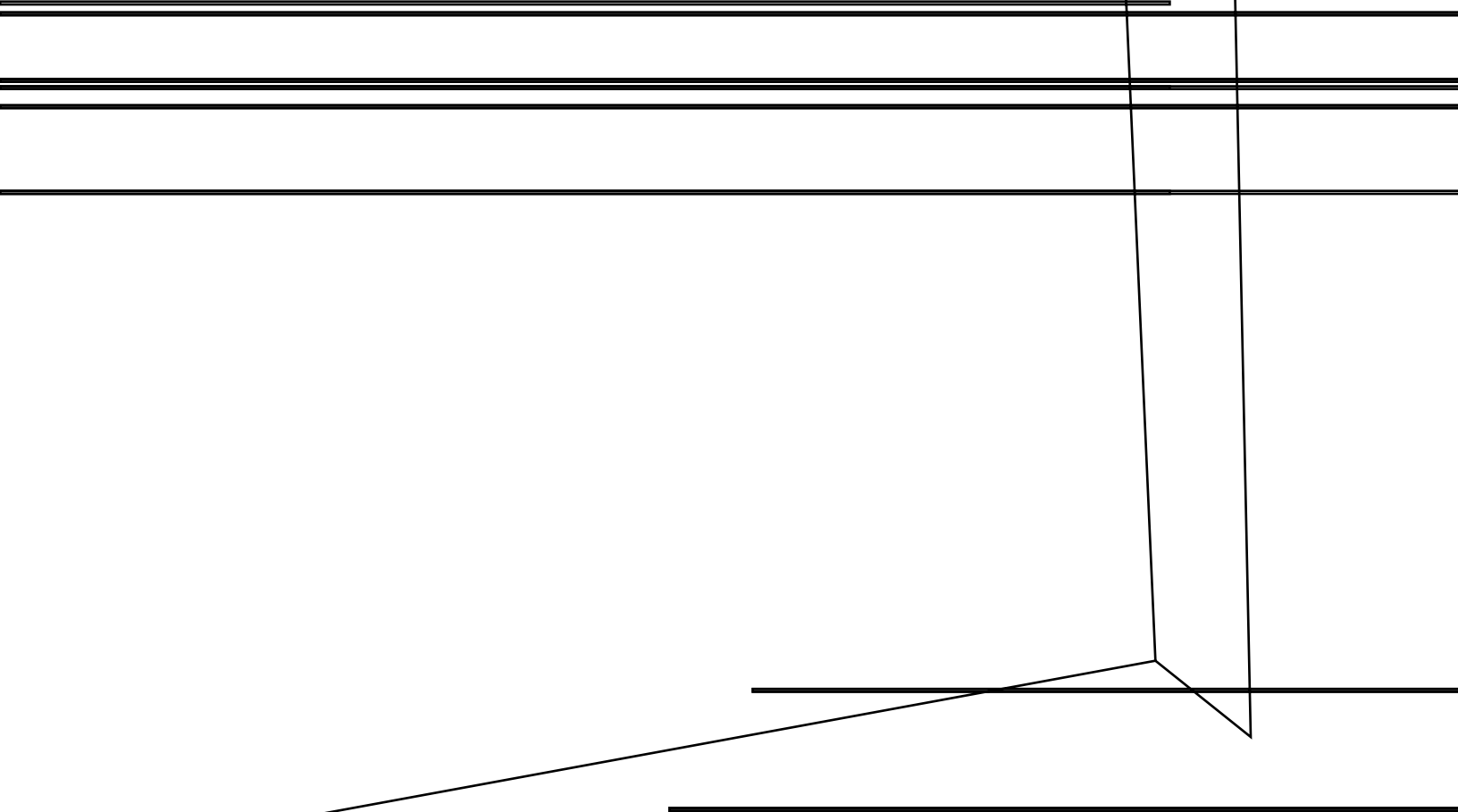

Type B3 Drive

For 4.5GB drives, 68-pin model.

Bright metal lid

SCSI ID Jump

7 2 1 0 Bla

Pin 2
Pin 1

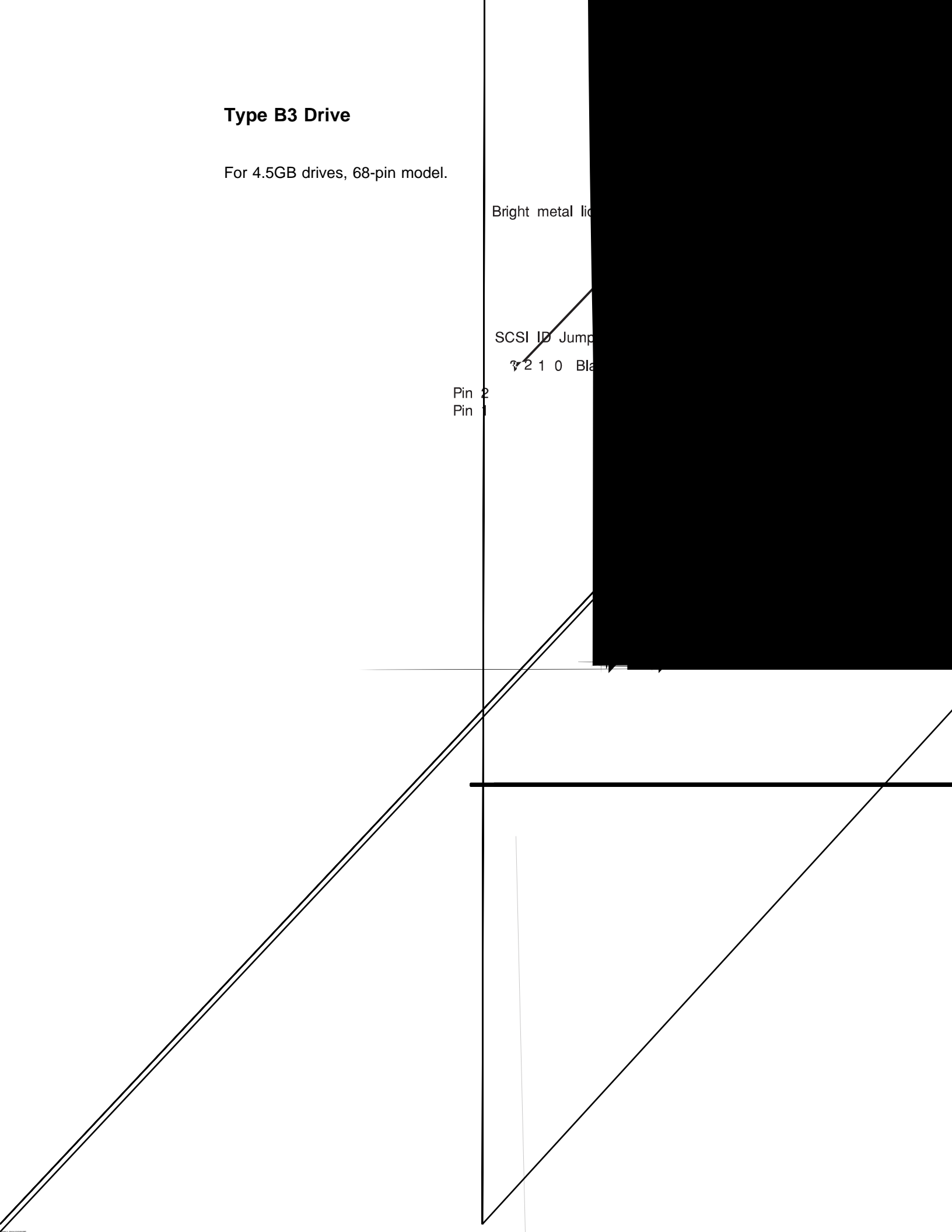

Type C2 Drive

For 2.2GB drives, 68-pin model.

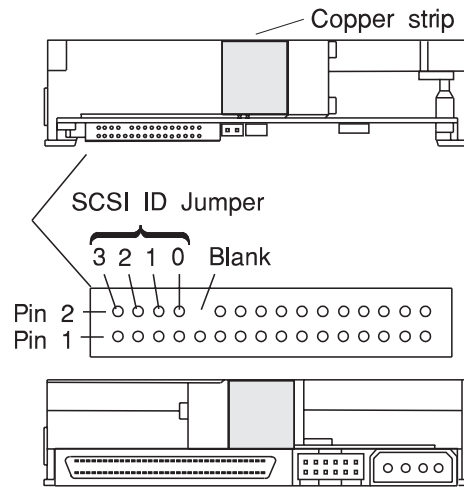

Type C3 Drive

For 4.5GB drives, 68-pin model.

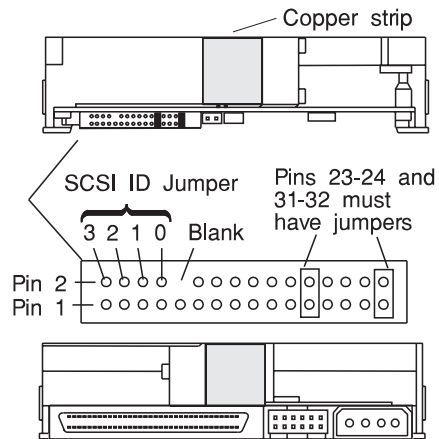

Type C4 Drive

For 9.1GB drives, 68-pin model.

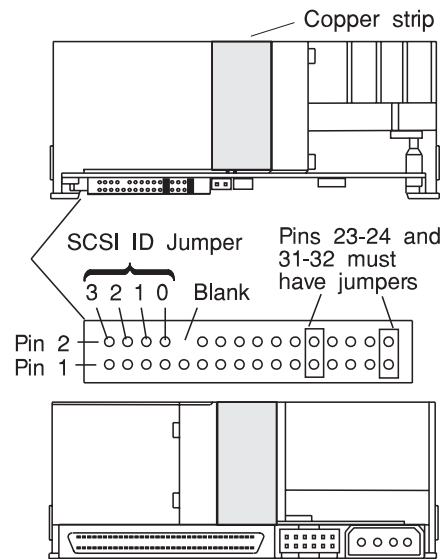

Type C5 Drive

The type C2 2.2GB, 68-pin (16-bit) disk drive can be used as a 50-pin (8-bit) drive by adding a jumper.

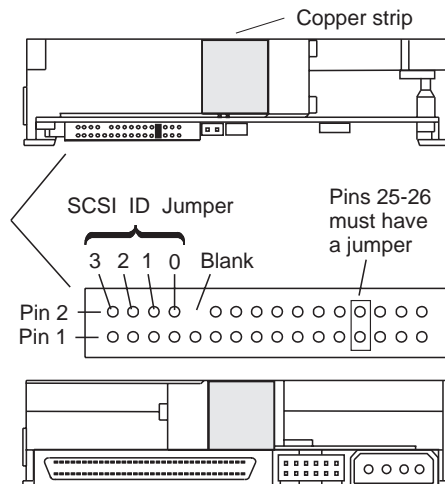

- Pins 25 and 26 must be jumpered together as shown in the figure above.
- Jumper 3 on pins 1 to 2 is not used in this configuration. Do not place a jumper on these pins. Eight bit devices can only use SCSI ID's zero (0) through six (6).
- Some systems require a 68-pin to 50-pin interposer, made up of a short cable and interposer as shown below.

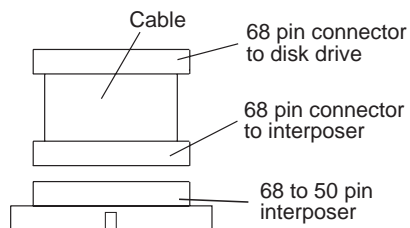



Type D3 Drive

The type D1 2.2GB, 68-pin (16-bit) disk drive can be used as a 50-pin (8-bit) drive by adding a jumper.

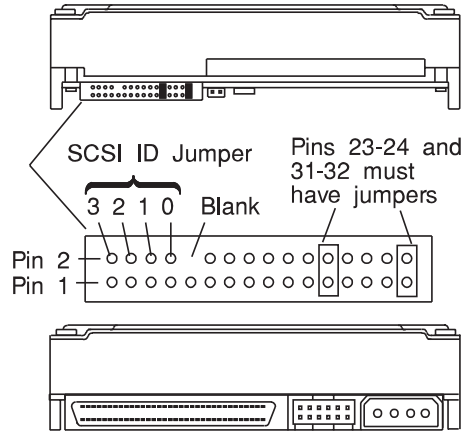

- Pins 23 and 24 must be jumpered together as shown in the figure above.
- Jumper 3 on pins 1 to 2 is not used in this configuration. Do not place a jumper on these pins. Eight bit devices can only use SCSI ID's zero (0) through six (6).
- Some systems require a 68-pin to 50-pin interposer, a cable and interposer or an interposer cable as shown below.

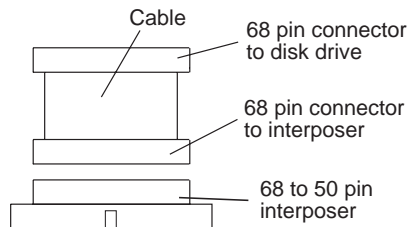

- When this disk drive is used on a Machine Type 7015 Models R20, R30, R40, or R50, the terminator power jumper (2.5 mm) must be installed. See figure below.

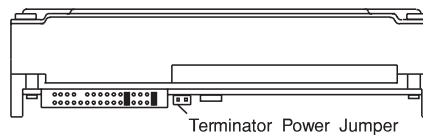

Type E1 Drive

For 9.1GB drive, 68-pin model.

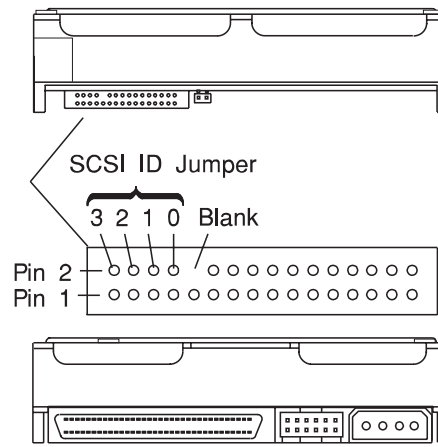

Valid Addresses (SCSI IDs)

Address	Jumper 3	Jumper 2	Jumper 1	Jumper 0
0	Off	Off	Off	Off
1	Off	Off	Off	On
2	Off	Off	On	Off
3	Off	Off	On	On
4	Off	On	Off	Off
5	Off	On	Off	On
6	Off	On	On	Off
7*	Off	On	On	On
8	On	Off	Off	Off
9	On	Off	Off	On
10	On	Off	On	Off
11	On	Off	On	On
12	On	On	Off	Off
13	On	On	Off	On
14	On	On	On	Off
15	On	On	On	On

Note:

1. Address 7 is reserved for the adapter.
2. There is no jumper 3 on 50 pin drives, thus SCSI addresses eight to fifteen are not valid.

1.37GB SCSI Disk Drive

The 1.37G-byte SCSI disk drive is a 5-1/4 inch fixed-disk drive. This drive mounts into a full-high media position.

Setting the SCSI Address Jumpers

The SCSI address of the 1.37G-byte SCSI disk drive is set with three jumpers on the top rear of the drive.

Note: Address jumper block configurations differ; compare your drive to the illustrations below and on the following page.

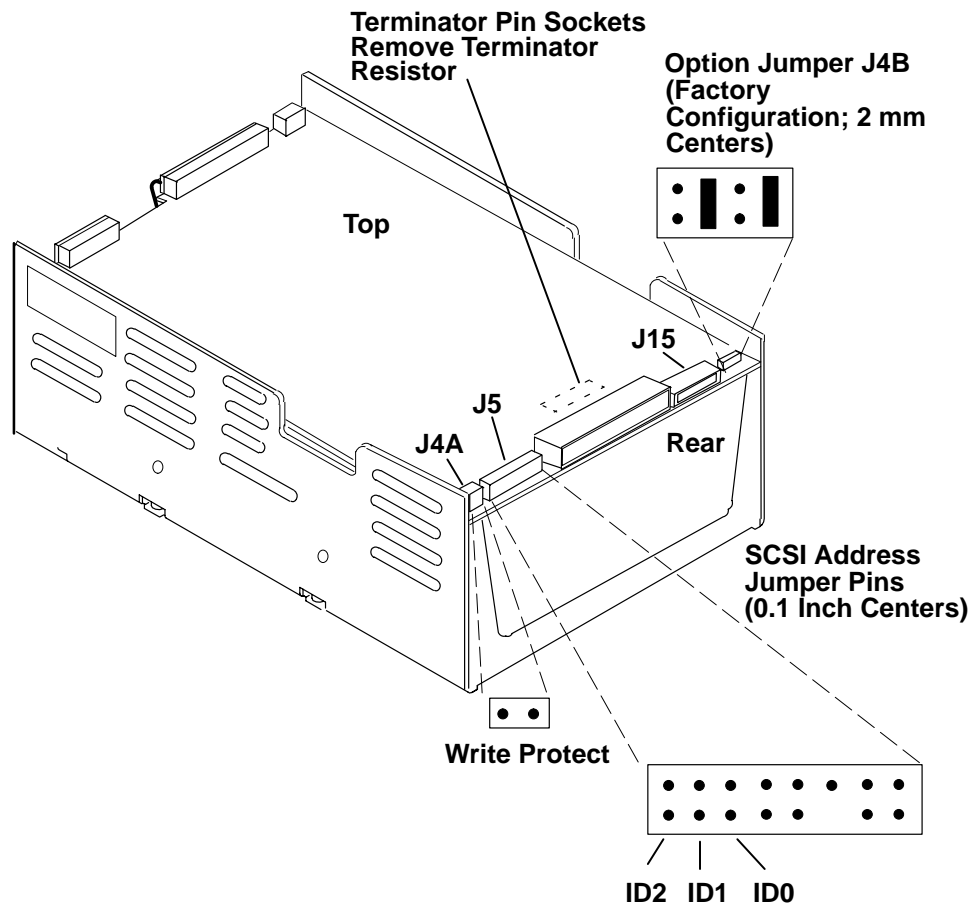

Note: The ID2, 1, and 0 pins on J5 use 0.1 inch (on center) jumpers (P/N 61X7052); option jumpers elsewhere on the drive use 2 mm jumpers (P/N 65F1103).

Valid Addresses

Address	Jumper ID2	Jumper ID1	Jumper ID0
0	Off	Off	Off
1	Off	Off	On
2	Off	On	Off
3	Off	On	On

Address	Jumper ID2	Jumper ID1	Jumper ID0
4	On	Off	Off
5	On	Off	On
6	On	On	Off

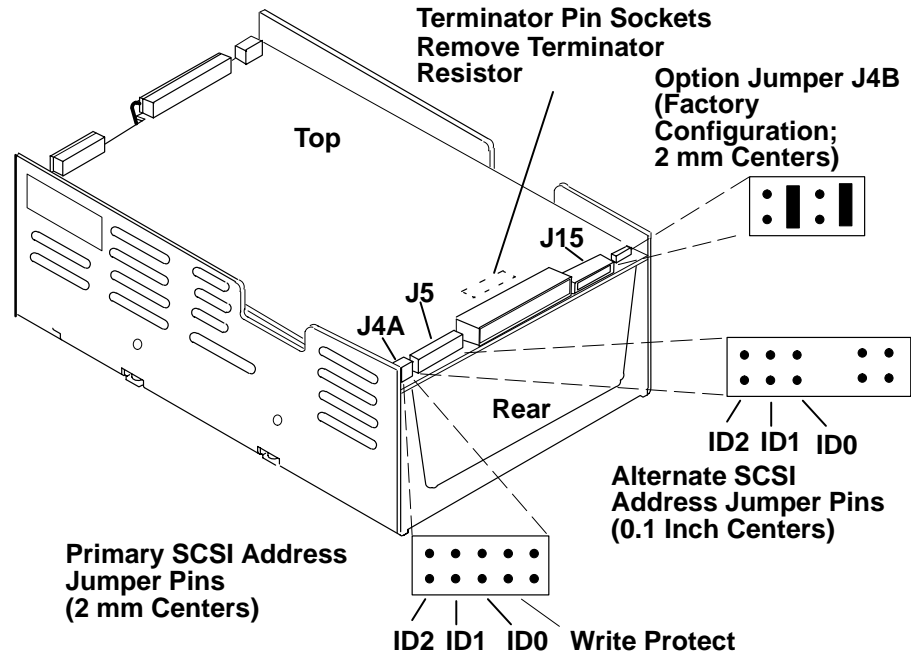

Note: The primary ID2, 1, and 0 pins on J4A use 2 mm (on centers) jumpers (P/N 65F1103). Alternatively, SCSI addressing can be accomplished by using 0.1 inch (100 mil) jumpers (P/N 61X7052) in the adjacent J5 jumper block.

Valid Addresses

Address	Jumper ID2	Jumper ID1	Jumper ID0
0	Off	Off	Off
1	Off	Off	On
2	Off	On	Off
3	Off	On	On
4	On	Off	Off
5	On	Off	On
6	On	On	Off

Exchanging the Logic Card

The logic card on the 1.37G-byte Disk Drive can be removed without removing the disk drive module. Use the following procedure:

1. Remove the disk drive from the system (refer to the installation and service guide for the system unit or device).

2. Place the disk drive on a flat work surface that offers electrostatic discharge protection, and use an electrostatic wrist strap.

Attention: The flex circuit is fragile. Avoid unnecessary bending of the circuit when connecting and disconnecting flex circuit connectors from circuit board connectors. Use an IC removal tool (*not* tools like screwdrivers or pliers) to disconnect flex circuit connectors. *If the flex circuit becomes damaged, the entire disk drive module must be replaced.*

3. Carefully grasp flex circuit connector **P30** with an IC removal tool. Avoid unnecessary rocking of the flex circuit assembly while pulling **P30** away from **J30**.
4. Remove the four T-10 Torx screws that secure the logic card to the disk drive.
5. Grasp the logic card at the address jumper end, and separate connectors **J23** and **P23** by wiggling the logic card slightly while pulling the logic card away from the power board.
6. Remove the logic card, and place it on an appropriate work surface.

Note: Ensure that the foam acoustic insulation pad (if present) remains in place between the logic card and disk drive module.

7. Reassemble the logic card to the disk drive module by reversing the preceding steps.

Note: All Terminator resistors must be removed from the logic card.

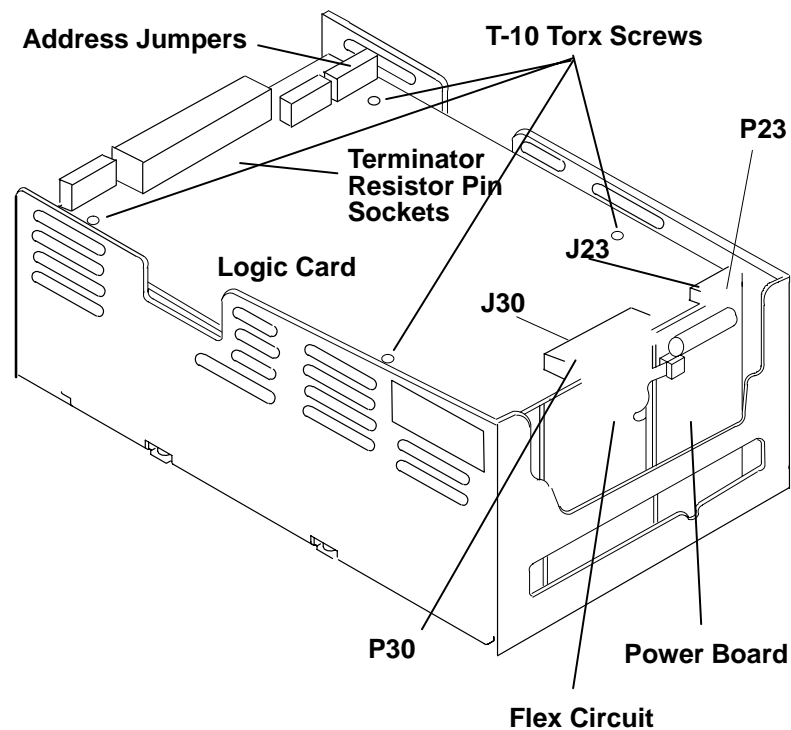

2.0G-byte SCSI-2 Single-Ended and Differential Disk Drives

The 2.0G-byte SCSI-2 disk drives are high performance, 3.5-inch, form factor disk drives that have single-ended or differential interfaces. Fast (10MB/sec) and fast/wide (20MB/sec) drives are available with single-ended or differential interfaces.

Connect single-ended drives to single-ended controllers; connect differential drives to differential controllers. Refer to "Cabling SCSI Devices" on page 4-3 for more information on cabling SCSI controllers and devices.

Note: SCSI-2 single-ended and differential disk drives are shipped with no jumpers installed.

Setting the SCSI Address or SCSI ID

Use the following illustrations to locate the jumper blocks and set the SCSI address.

Differential Drives with 50-Pin Connector (Fast 10MB/sec)

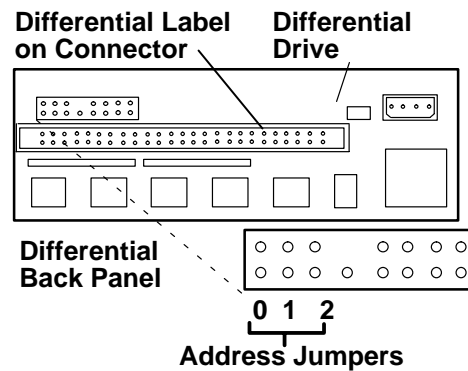

Address	Jumper 0	Jumper 1	Jumper 2
0	Off	Off	Off
1	On	Off	Off
2	Off	On	Off
3	On	On	Off
4	Off	Off	On
5	On	Off	On
6*	Off	On	On
7*	On	On	On

Note: * Address 7 is usually reserved for the adapter; in high-availability configurations, the second adapter is usually assigned address 6.

Single-Ended Drives with 50-Pin Connector (Fast 10MB/sec)

Type A DriveBackPanel0 1 2Address Jumpers50-Pin SCSIConnectorSingle-endedD

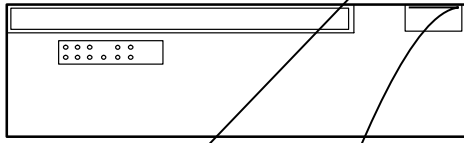

Single-Ended and Differential Drives with 68-Pin Connector (Fast/Wide 20MB/sec)

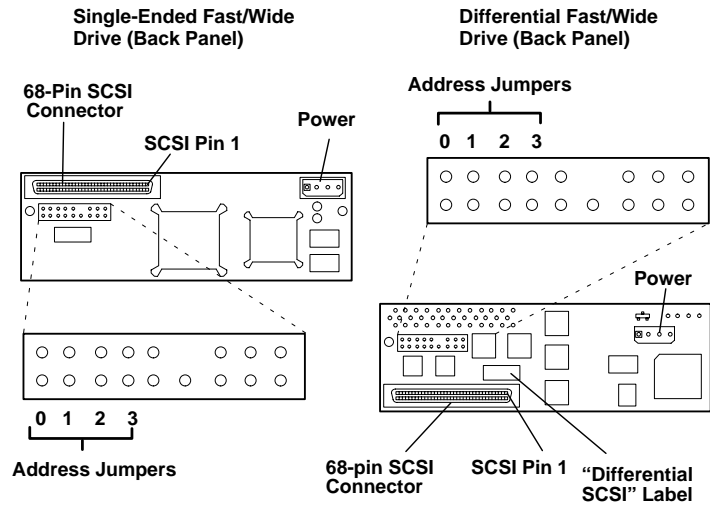

Addresses

Address	Jumper 0	Jumper 1	Jumper 2	Jumper 3
0	Off	Off	Off	Off
1	On	Off	Off	Off
2	Off	On	Off	Off
3	On	On	Off	Off
4	Off	Off	On	Off
5	On	Off	On	Off
6*	Off	On	On	Off
7*	On	On	On	Off
8	Off	Off	Off	On
9	On	Off	Off	On
10	Off	On	Off	On
11	On	On	Off	On
12	Off	Off	Off	On
13	On	Off	On	On
14	Off	On	On	On
15	On	On	On	On

Note: * Address 7 is usually reserved for the adapter; in high-availability configurations, the second adapter is usually assigned address 6.

Exchanging the Frame Electronics

Refer to the procedures that were packed with the FRU.

2.4G-byte SCSI Disk Drive

The 2.4G-byte SCSI disk drive assembly contains two independently addressable 3-1/2 inch Head Disk Assemblies (HDAs) mounted in a 5-1/4-inch form factor enclosure. An available field repair kit includes one Head Disk Assembly (HDA), the electronics planar and the 5-1/4-inch form factor enclosure ("cage"). For applicable FRU numbers, refer to Failing Functional Codes C11 and 986 in Chapter 3 of the *Diagnostic Information for Micro Channel Bus Systems*, order number SA23-2765.

Setting the SCSI IDs (Addresses)

The SCSI addresses of the 2.4G-byte SCSI disk drive are set with two ID (address) groups (HDA A and B) on the connector end of the drive.

Note: Each of the two HDAs must be assigned its own, unique SCSI ID (address); the system configures two individual SCSI drives.

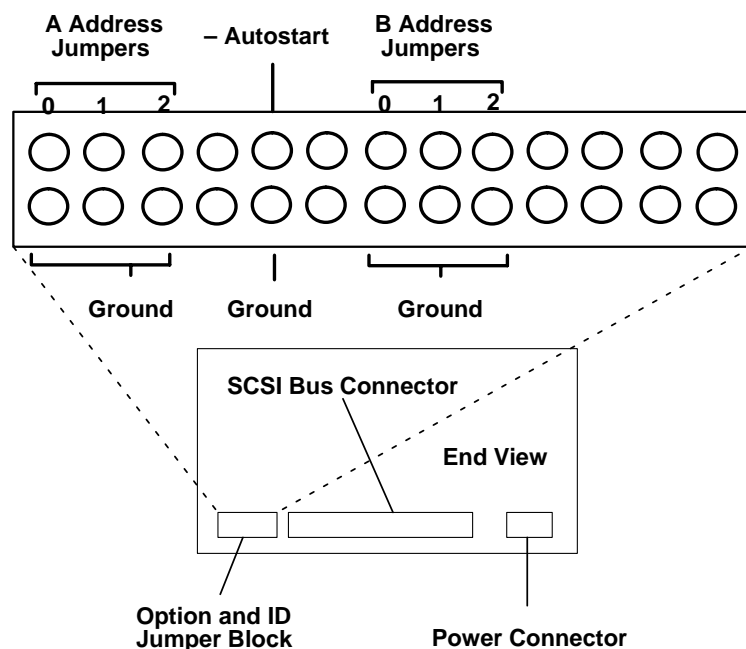

Valid Addresses

Address	Address Jumper 0	Address Jumper 1	Address Jumper 2
0	Off	Off	Off
1	On	Off	Off
2	Off	On	Off
3	On	On	Off
4	Off	Off	On
5	On	Off	On
6	Off	On	On

Note: "On" in the preceding table means that the jumper is installed between the address pin and its corresponding ground pin.

HDA Removal and Replacement

Contained within the 5-1/4 inch form factor enclosure (cage) are two 3-1/2 inch head drive assemblies (HDAs) (each containing a data channel card) and an electronics planar. Field replacement options are 1) replace the entire two-HDA assembly or 2) assuming that only one HDA has failed, remove the “good” HDA, and install it in the Field Repair Kit which comprises one complete HDA, an electronics planar, and the 5-1/4 inch form factor cage.

Note: As a final effort to save critical data from the “failed” HDA, that drive may be temporarily substituted for the “good” drive that has been installed in the Field Repair Kit. If the “failed” drive then functions properly, the problem was probably in the electronics planar. If possible, back up data from the “failed” HDA, and return it to the factory for analysis. Keep the “good” HDA, along with the new HDA from the Field Repair Kit.

Special Tools Required:

- Torx™ T7 bit, 37F8396
- Torx™ T20 bit (tamper-proof), 39F8401

Note: Torx™ set, 39F8407, includes the T7 and T20 bits.

- Holding clip removal tool (included with field repair kit; not available separately).

HDA Removal

Note: The HDA removal procedure is the same for either of the two HDAs; the following illustrations portray removal of HDA B.

1. Remove the cage top cover by loosening the top cover Torx™ T20 screws [2], and then lifting cover off the tabs [1] in the lower frame.

Note: Some versions of the top cover may have rear interlocking tabs that do not fit under screws.

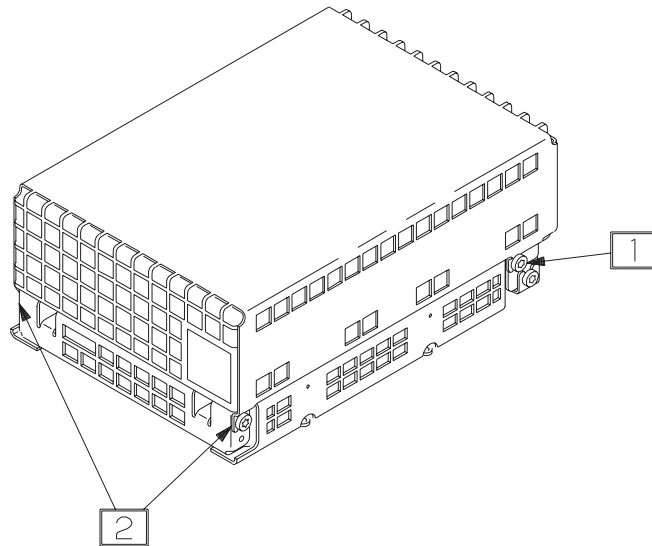

Attention: The flex cable can be torn by excessive force, or signal lines can be broken by bending the cable sharply.

2. Disconnect the data channel flex cable by:

- a. Orienting the HDA so that the channel data card [1] is in front of you.
- b. Releasing the flex cable connector by pulling both ends of the connector forward as shown.
- c. Pulling the flex cable from the back of the disk enclosure when the jumper wire shown below is removed from the data channel card.

3. Remove the three Torx™ T7 screws [1] that hold the channel data card to the frame.

4. Lift up the jumper wire shown in the enlargement, but do not lift up the channel card at

Attention: In the following step, ensure that you lift the data channel card [2] around the plastic retainer, or the data channel card may be damaged.

5. Lift the channel data card [2] up from the HDA, and hold it at an angle so that you can easily get access to the connector [3].
6. Remove the spacer [1] from the top of the HDA. Note how the spacer is installed so that you can reinstall it correctly.

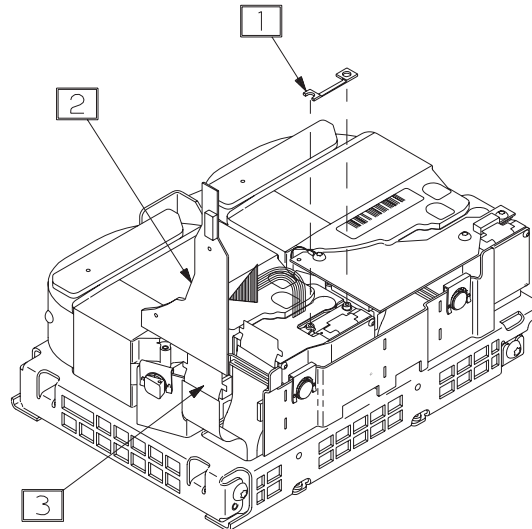

7. Release the flex cable connector [1] by pulling up on both ends of the connector.
8. Pull the flex cable from the connector, and put the data channel card on an ESD-protected work surface.

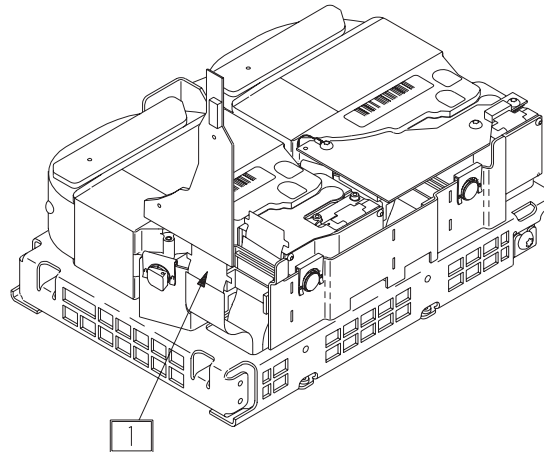

Attention: The flex cable can be torn by excessive force, or signal lines can be broken by bending the cable sharply.

9. Disconnect the actuator flex cable by:
 - a. Releasing the flex cable connector by lifting up on both ends of the connector with the holding clip removal tool [1].
 - b. Pulling the flex cable [2] from the connector.

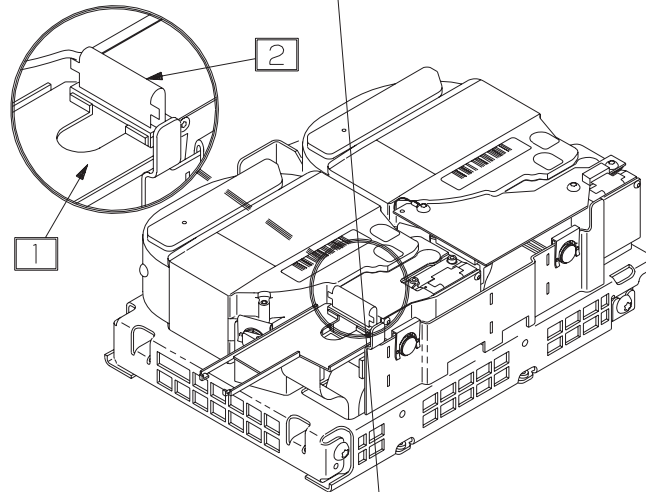

10. Locate three holding clips [1], [2] and [3].

Note: The cut tabs [4] (notches in the metal) that lock the holding clips to the frame are on the outside of the frame.

11. Place the holding clip removal tool over the holding clip as shown; the flat part of the tool should be against the HDA frame.
12. Pull up on the holding clip removal tool until the holding clip comes off the shock mount.

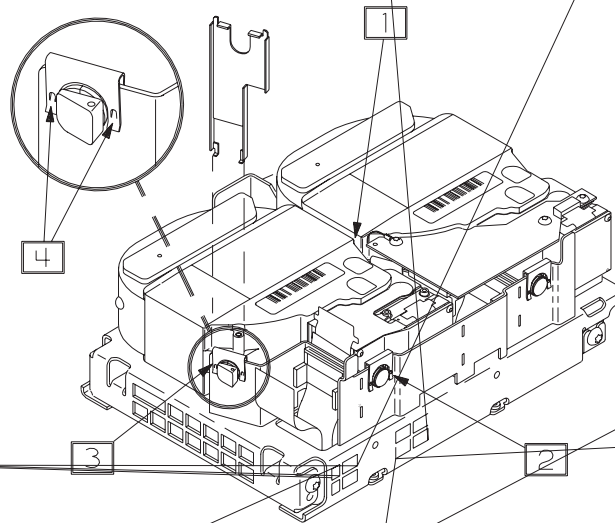

Attention: Do not hold or apply pressure to the HDA cover (shaded area in the illustration) the HDA cover may touch and damage the disks inside.

Note: In the two following steps, only loosen the HDA; do not lift it out yet.

13. Loosen the damper spring screw.
14. Loosen the HDA by first grasping the front and left shock mounts [3] and pulling up. Then, grasp the HDA just above the right shock mount [2], and pull up.

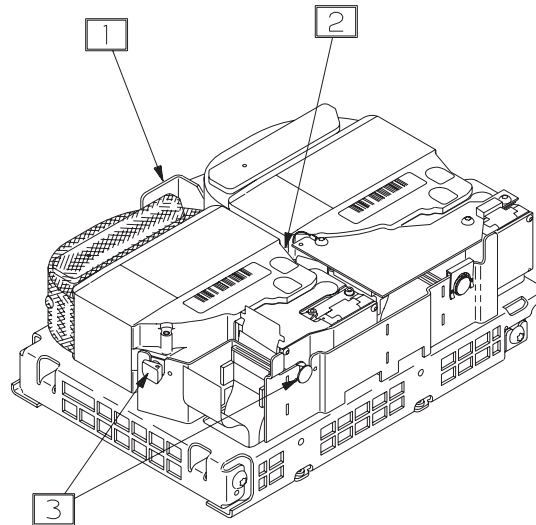

Attention: The HDA has no shock protection when removed from the frame. The HDA must be held by the shock mounts with extreme care.

Attention: The motor cable is attached to the bottom of the HDA. Be careful not to lift the HDA too high, or this short cable may break.

Attention: Do not hold or apply pressure to the HDA cover (shaded area in the illustration); the HDA cover may touch and damage the disks inside.

15. *Holding the shock mounts [1] only at the points shown*, lift the HDA from the frame.
16. Hold the HDA by the shock mounts on the ESD-protected work surface with the motor cable up.

Note the position of the motor cable and how it attaches to its connector [1]; the motor cable must be in the same position when it is reconnected.

Remove the motor cable from its connector by pulling up on the tab [2] This completes
HDA Replacement Hold the HDA by the shock mounts so that it is standing up on the ESD-protected

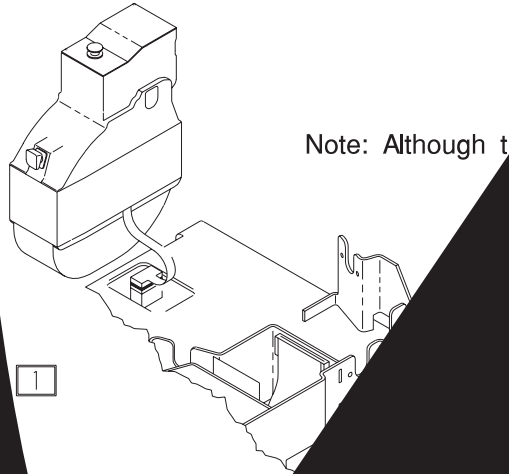

Attention: Hold the HDA by the shock mounts. *Ensure that the motor cable is not twisted.*

3. Align the front shock mount [3] with the slot on the connector end of the frame.
4. Align the side shock mounts [2] and [4] with the slot on the connector end of the frame.
5. Push down on the side shock mounts at points [2] and [4] to seat the HDA.
6. Tighten the damper spring screw [1] that is against the rear of the HDA.

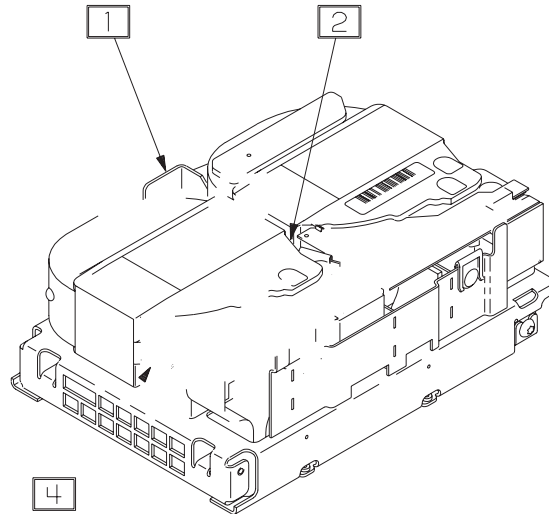

Attention: The flex cable can be torn by excessive force, or signal lines can be broken by bending the cable sharply.

8. Lift up on both ends of the connector with the holding clip removal tool [1].
9. Push the flex cable [2] all the way into the connector until the flex cable tabs touch the connector.

Note: The flex cable tabs do not touch the connector after the connector is sealed.

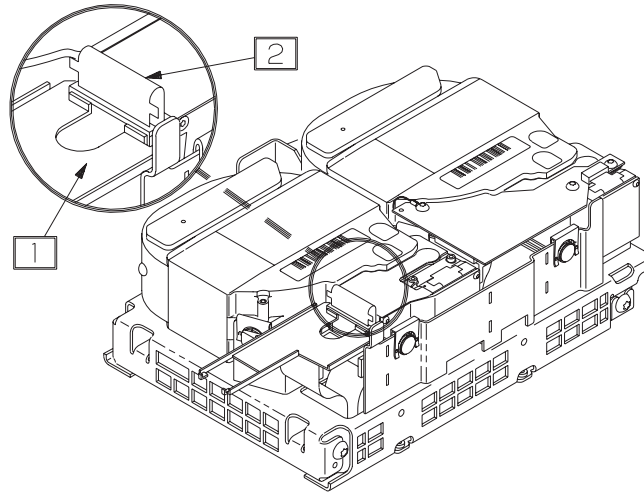

10. Push the read/write flex cable [1] into the end of the connector, and push the tabs on the connector edge down to fasten the cable.
11. Ensure that the spacer [2] is in the correct position as shown.
12. Hold the data channel card in place on the frame.

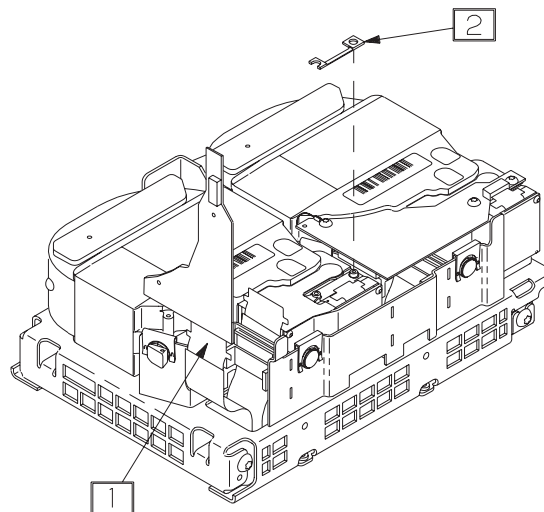

Attention: There is a greater risk of ESD damage to the HDA when the jumper wire shown below is removed from the data channel card. *Ensure that the jumper wire is installed in the following step.*

13. Install three Torx™ T7 screws [1] that hold the data channel card to the frame, with the jumper wire under the screw as shown. Ensure that the jumper wire is routed between the HDA and the data channel card to avoid interference when you replace the top cover.

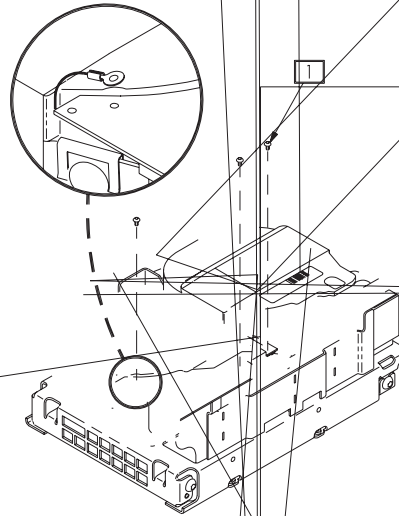

17. Place the two tabs [1] into the lower frame, and tighten the top cover Torx™ T20 screws [2].

Note: Some versions of the top cover may have rear interlocking tabs that do not fit under screws.

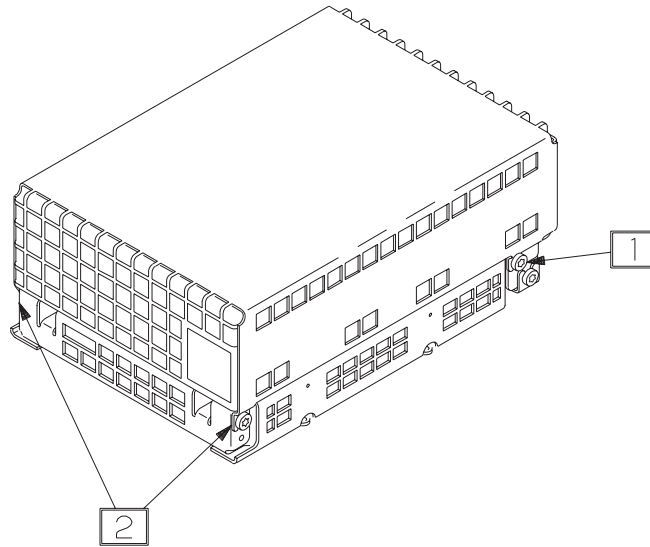

Chapter 3. Cables and Cabling

This chapter has information for those servicing installed systems and to help those planning for new installations. There is information that describes cabling to the standard interfaces that come in the system and cabling to the many optional adapters that are used with the system.

In most cases when a system unit is getting attached to large computer systems, file systems, or networks, the cabling is complicated and the appropriate publications for those specific products are required for cabling and setup.

Chapter 4 has all of the information about SCSI cabling.

Chapter 5 has information on cable building and pin-outs that may be helpful if you are considering custom built cables.

Adapter Cabling

This section helps you determine the types of cables you need to attach devices to their adapters. *Length* refers to the length of a cable. There are many general purpose cables shown in this section. However, there are many cases where custom cables are required when installing large or complicated systems. Chapter 5 provides pin-outs and in some cases additional information that may help you or your cable vendor build these cables.

If there are custom built cables used with your system, be sure to read the applicable sections in chapter 5 of this book and in the *Site and Hardware Planning Information*. Order number SA38-0508.

Communications Adapter Cabling

This section provides information on cabling for communications adapters.

There are many ways to connect communications cables and devices. Because each installation may have unique requirements, the following topics present attachment configurations using part-numbered cables. These drawings are not the only ways you can cable devices to a system; see Chapter 5 for additional information about custom built cables.

EIA-232 Cabling Considerations

Attention: EIA-232 asynchronous adapters may be damaged if the following cabling practices are not observed:

Note: Use of the following recommendations are not a guarantee of compliance with FCC EMI/RFI regulations.

- Cable directly, as described in the Hardware Offerings overview manual, since there should then be no Electrical Static Discharge (ESD) entry point other than a charged cable.
- Discharge cables before plugging into adapters or interface cable ports (fanout box).
- Do not allow conductors, leads, or pins to be exposed to the touch of non-anti-static-protected persons.

- Avoid the use of Type 66 Punchdown or similar terminal blocks. If these terminal blocks must be used, ensure that the person handling interface wires is using appropriate ESD precautions such as ground straps and grounded floor mats, and that grounded equipment covers that require touching before access are in use. These precautions must be taken even if power is off, since ESD damage is independent of circuit power.
- Eight- and sixteen-port adapter cables should not be used outdoors. Such outdoor use is at the customer's risk, and an appropriate transient voltage suppression device should be used on *each signal wire in the cable* at every exit or entry point.
- Do not route cables near or around power cables, power transformers, or high power switching devices such as air conditioners, refrigeration units, or elevators.

Note: The 78-pin multiport interface cables for the 8-or 16-port Async Adapters when used with the 7015 Models R10 and R20 attach to the system tailgate rather than to the adapter itself. Internal cables not shown in the cable diagrams run from the adapter through the cable management arm to the tailgate connector.

- Shielded cables are essential to prevent damaging high voltage noise impulses from coupling onto signal lines. The shielded cable should be data grade, at least 24 AWG, and of individual shielded twisted pairs. Shielding should have both overall shorted aluminum foil to suppress high frequency noise and tinned copper braid (capacitance approximately 12pF per foot, not to exceed 2500pF in the recommended maximum cable length of 200 feet) to suppress low frequency noise. Shielded connectors with metal shrouds are also recommended, as are cable strain reliefs.

Note: Twisted pair cable with only overall aluminum foil shielding, as described above, may be used if the signal conductors are carefully bundled to prevent crosstalk.

- If the cable is routed from the system (fanout box) to the I/O device, the shields and drain wire should be connected to the metal shell of the connector at the system end. At the I/O device end, the drain wire should be connected to Pin 1, and the shields should be connected to the metal shell of the connector. If a cable similar to the Async cable is to be attached from the system (fanout box) to a permanently installed cable, frame ground should be present on Pin 1 and on both ends of the permanently installed cable.
- Excessive cable lengths expose the system to more noise. Maximum supported cable length is 200 feet for EIA-232 applications.
- The cable should not contain unterminated (connected at one end only) wires. Unterminated wires act as antennas and can pick up or emit electrical noise.
- Do not tie the frame (shield) ground to the signal ground within the cable or connector.

FC 2930 (8-Port Async Adapter-EIA-232)

The following figure illustrates the 8-Port Async Adapter-EIA-232 with the Multipoint Interface Cable and attachment cables. The cable assembly ports are labeled 0 through 7. Attachment cables can connect to any of the eight ports. In order to make the necessary connections to this adapter, your setup person needs to know the devices and persons assigned to each port.

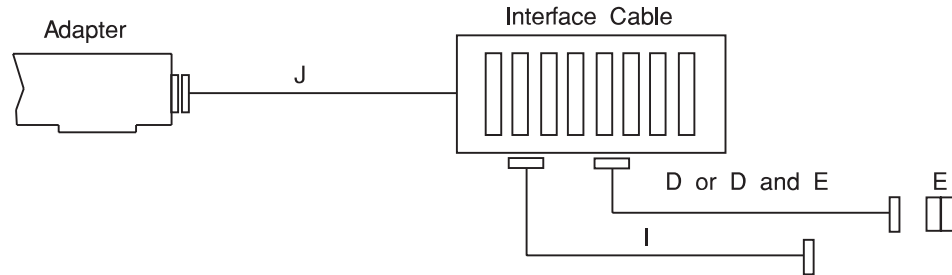

Cable Letter	Cable Name/Description	Part Number	Feature Code	Length	
				m	ft
J	Part of cable assembly	00F5531	2995	3	10
D	Async Cable-EIA-232/V.24, if customer-supplied, must meet EIA-232D requirements	6323741	2936	3	10
E	Printer/Terminal Interposer EIA-232	58F2861	2937	N/A	
I	Printer/Terminal Cable EIA-232 if customer-supplied, must meet EIA-232D requirements	12H1204	2934	3	10

FC 2940 (8-Port Async Adapter-EIA-422A)

The following figure illustrates the 8-Port Async Adapter-EIA-422A with the Multipoint Interface Cable and attachment cables. The cable assembly ports are labeled 0 through 7. Attachment cables can connect to any of the eight ports. In order to make the necessary connections to this adapter, your setup person needs to know the devices and persons assigned to each port.

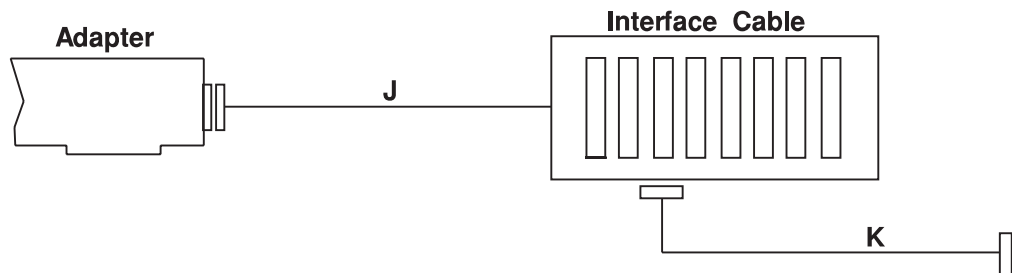

Cable Letter	Cable Name/Description	Part Number	Feature Code	Length	
				m	ft
J	Part of cable assembly	00F5531	2995	3	10
K	Terminal Cable-EIA-422A, if customer-supplied, must meet EIA-422A requirements	30F8966	2945	20	65.5

FC 2950 (8-Port Async Adapter MIL-STD 188)

The following figure illustrates the 8-Port Async Adapter MIL-STD 188 with the Multipoint Interface Cable and attachment cables. The cable assembly ports are labeled 0 through 7. Attachment cables can connect to any of the eight ports. In order to make the necessary connections to this adapter, your setup person needs to know the devices and persons assigned to each port.

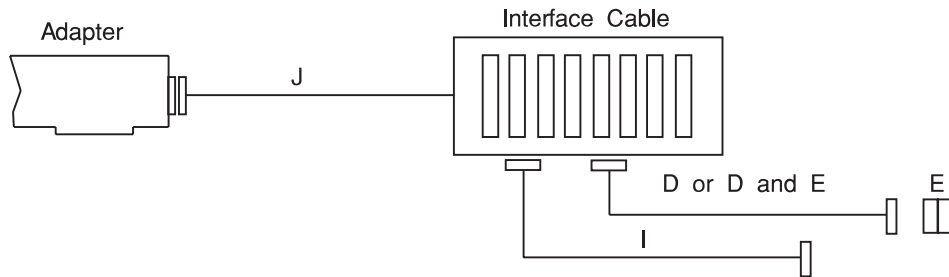

Cable Letter	Cable Name/Description	Part Number	Feature Code	Length	
				m	ft
J	Interface cable assembly	00F5531	2995	3	10
D	Async Cable-EIA-232/V.24, if customer-supplied, must meet MIL-STD 188 requirements	6323741	2936	3	10
E	Printer/Terminal Interposer EIA-232	58F2861	2937	N/A	
I	Printer/Terminal Cable EIA-232 if customer-supplied, must meet EIA-232D requirements	12H1204	2934	3	10

FC 2955 (16-Port Async Adapter-EIA-232)

The following figure illustrates the adapter with the 16-Port Interface Cable-EIA-232 and attachment cables. The cable assembly ports are labeled 0 through 15. Attach cables can connect to any of the 16 ports. In order to make the necessary connections to this adapter, your setup person needs to know the devices and persons assigned to each port.

Cable Letter **Cable Name/Description** **Part Number** **Feature Code** **Length**

Cable Letter	Cable Name/Description	Part Number	Feature Code	Length m ft
M	Interface cable assembly	43G0463	2997	3 10
	EIA-232D requirements	632374129363	10E	
	Printer/Terminal Interposer	EIA-23258F28612937	N/AI	Printer
	EIA-232D requirements	12H120429343	10F	

Cable Letter	Cable Name/Description	Part Number	Feature Code	Length m ft
M	Interface cable assembly	43G0462	2997	3 10

Cable Letter	Cable Name/Description	Part Number	Feature Code	Length m ft
K	Terminal Cable-EIA-422A, if customer-supplied, must meet EIA-422A requirements	30F8966	2945	20 65.5

FC 6400 (Async Device Attached to a 64-Port Async Controller)

Use this drawing only for the 64-port async controller and 16-port async concentrator.

Use this drawing when connecting async devices or communications devices to the 64-port async controller. Each 64-port controller can support up to four 16-port concentrators.

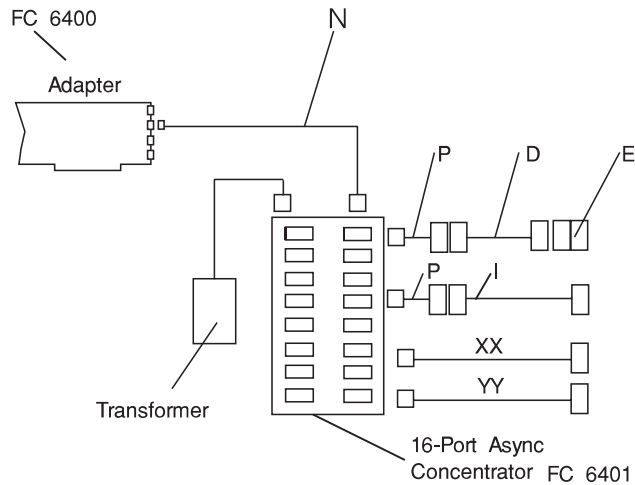

Cable Letter	Cable Name/Description	Part Number	Feature Code	Length	
				m	ft
D	Async Cable EIA-232/V.24, if customer-supplied, must meet EIA-232D requirements	6323741	2936	3	10
E	Printer/Terminal Interposer EIA-232	58F2861	2937	N/A	N/A
I	Printer/Terminal Cable EIA-232 if customer-supplied, must meet EIA-232D requirements.	12H1204	2934	3	10
N	Controller to concentrator cable if customer-supplied, must meet EIA-232D requirements.	00G1109		7.6	25
P	RJ-45 to DB-25 converter cable Note: Only available as four-cable kit. If customer-supplied, must meet EIA-232D requirements.	59F3432	6402	.45	1.5
XX	Directly wires RJ-45 to DB-25 connector for attaching a terminal or printer. See note.	N/A	N/A	N/A	N/A
YY	Directly wires RJ-45 to DB-25 connector for attaching a modem. See note.	N/A	N/A	N/A	N/A
Power Transformer	Power transformer 115 - 127 V ac	70F9938	N/A	N/A	N/A
	Power transformer 100 - 110 V ac	70F9937	N/A	N/A	N/A
	Power transformer 200 - 220 V ac	70F9939	N/A	N/A	N/A
	Power transformer 230 - 240 V ac	70F9940	N/A	N/A	N/A

Note: This customer supplied cable must meet EIA-232D electrical requirements.

FC 8128 (128-Port Async Controller)

A number of cabling scenarios are possible when installing this feature. The following figure shows a typical configuration in which eight Remote Async Nodes are attached to the 128-Port Async Controller using both 4-wire and 8-wire direct cabling. Note that in the figure below, the 128-Port Async Controller supports up to four Remote Async Nodes on each controller. Cables NB and NC are available or can be customer supplied. The ND cable in the configuration below is a customer-supplied cable. See "128-Port Async Controller" on page 5-28.

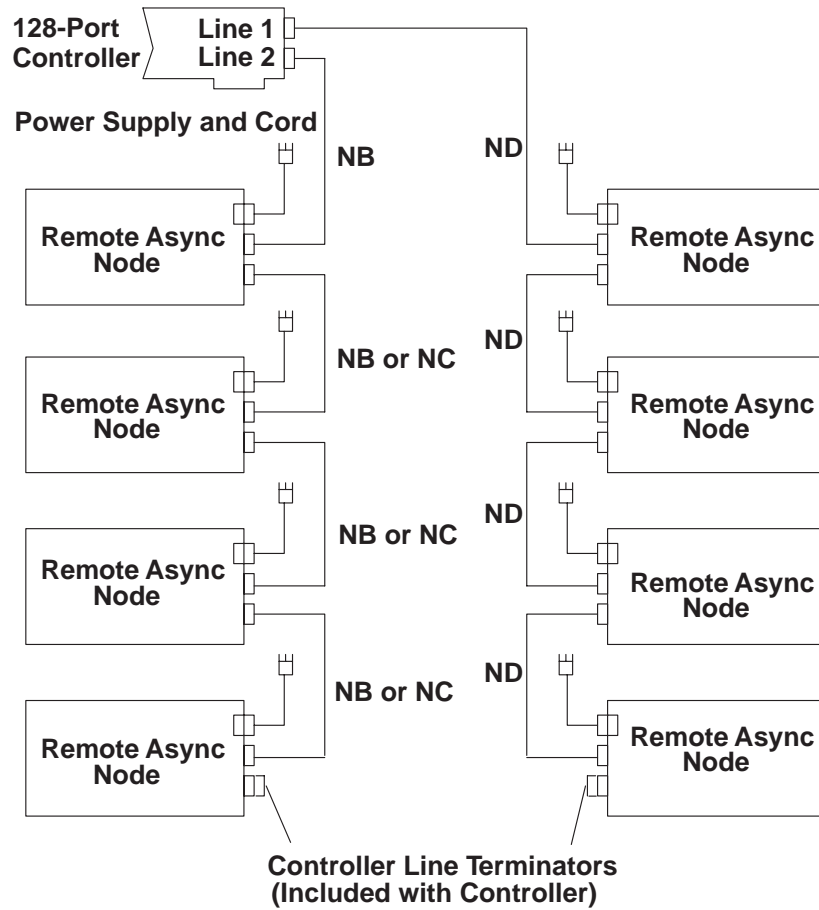

A choice of cables can be attached to any of the 16 Remote Async Node ports. See the following illustration. These ports are labeled 0 through 15 and accept 4-, 6-, 8-, and 10-pin RJ-type connectors.

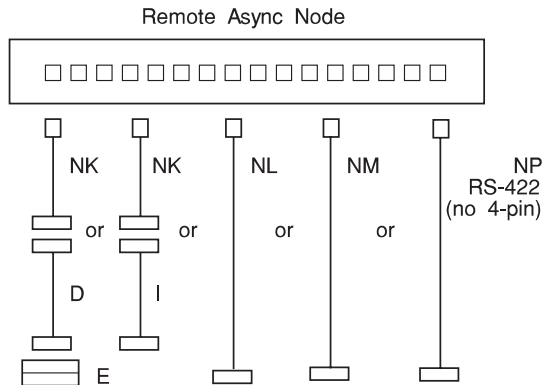

In order to make the necessary connections to the Remote Async Node, the system administrator must know the type of device that is being configured and its port location on the Remote Async Node. The cable planning charts section of the *Site and Hardware Planning Information*, order number SA38-0508 can help you make these assignments.

The following table shows the cables that are used to configure the 128-Port Async Controller, see "128-Port Async Controller" on page 5-28, for information on cables that you can build yourself.

This references the top head ref in chapter 5 for 128 port.

Cable Letter	Cable Name/ Description	Part Number	Feature Code	Length	
				m	ft
NB	128-Port Async Controller Cable, 8-wire	43G0937	8131	4.57	15
NC	128-Port Async Controller Cable, 8-wire	43G0936	8132	.23	.75
ND	128-Port Async Controller Cable, 4-wire, customer-supplied	N/A	N/A	N/A	N/A
NE	128-Port Async Controller EIA-232 Modem Cable, system, customer-supplied	N/A	N/A	N/A	N/A
NF	128-Port Async Controller EIA-232 Modem Cable, device, customer-supplied	N/A	N/A	N/A	N/A
NG	128-Port Async Controller EIA-422 Modem Cable, system, customer-supplied	N/A	N/A	N/A	N/A
NH	128-Port Async Controller EIA-422 Modem Cable, device, customer-supplied	N/A	N/A	N/A	N/A
NK	RJ-45 to DB-25 Converter Cables (four provided with each order)	43G0935	8133	0.61	2

Cable Letter	Cable Name/ Description	Part Number	Feature Code	Length	
				m	ft
D	Async Cable EIA-232/V.24, if customer-supplied, must meet EIA-232-D requirements.	6323741	2936	3	10
E	Printer/Terminal Interposer EIA-232	58F2861	2937	N/A	
I	Printer/Terminal Cable EIA-232 if customer-supplied, must meet EIA-232-D requirements	12H1204	2934	3	10
NL	Cable directly wires RJ-45 to a DB-25 connector for attachment to a terminal or printer; customer-supplied, must meet EIA-232-D electrical requirements	N/A	N/A	N/A	
NM	Cable directly wires RJ-45 to a DB-25 connector for attachment to a modem; customer-supplied, must meet EIA-232-D electrical requirements	N/A	N/A	N/A	
NP	Cable for RS-422. Directly wires RAN to RS-422 device. RJ-45 to DB-25, customer-supplied, must meet RS-422 electrical requirements	N/A	N/A	N/A	
See Note	Cable converter 64-Port to 128-Port Pin-out converter Allows customers to use 64-Port Concentrator wiring with 128-Port Remote Async Node; if customer-supplied, must meet EIA-232-D electrical requirements	88G3650 (pkg of 4)	8135	N/A	

Note: This converter cable allows customers with installed 64-Port Async Card and 16-Port concentrators to convert the 8-wire wiring used with the 16-Port concentrators to the 10-wire wiring used with the 16-Port Remote Async Nodes that are used with the 128-Port Adapter.

FC 2921, 2924, 2928 (ARTIC960 Adapter)

The cabling options for the ARTIC960 Adapter (FC 2921, 2924, 2928) are shown below.

The AIB with the matching cable provide a choice of four interfaces:

- 4-Port EIA-232-D
- 4-Port EIA-530 (RS-422)
- 4-Port ISO 4902 (V.36)
- 4-Port ISO 4903 (X.21)

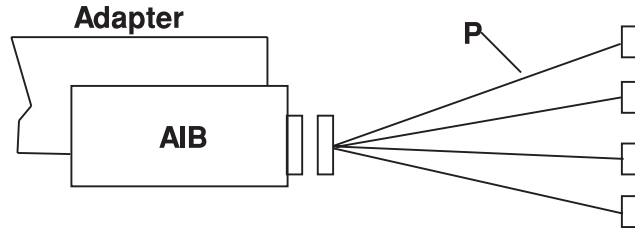

Cable Letter	Cable Name/Description	Part Number	Feature Code	Length	
				m	ft
P	Cable Option EIA 232D	61G2918	2922	1.8	6
	Cable Option EIA 530 (RS-422)	61G2923	2923	1.8	6
	Cable Option ISO 4902 (V.36)	61G2933	2926	1.8	6
	Cable Option ISO 4093 (X.21)	61G2928	2927	1.8	6

FC 2935, 2929, 2938 (ARTIC960 Adapter)

The cabling options for the ARTIC960 Adapter (FC 2935, 2929, 2938) are shown below.

The AIB with the matching cable provide a choice or three interfaces:

- 6-Port ISO 4902 (V.36)

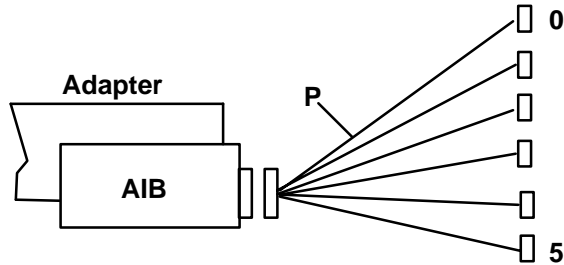

- 8-Port EIA-232-E
- 8-Port ISO 4903 (X.21)

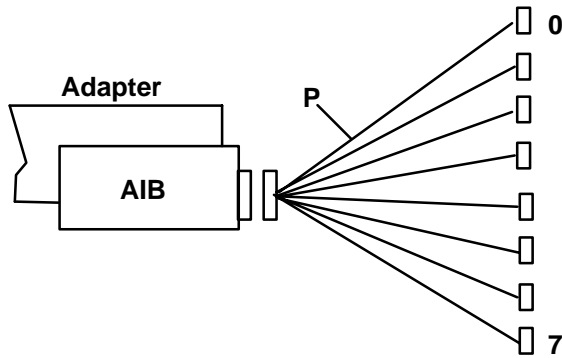

Cable	Cable Name/Description	Part Number	Feature Code	Length	
				m	ft
P	Cable Option EIA 232 E	71G3497	2939	1.8	6
	Cable Option ISO 4902 (V.36)	73H2507	2941	3	10
	Cable Option ISO 4093 (X.21)	06H4648	2942	1.8	6

FC 2959 (Multiprotocol Adapter/A)

The following figure illustrates the Multiprotocol Adapter/A with an industry-standard EIA 232-D with 25-pin D-shell connectors.

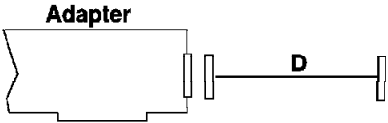

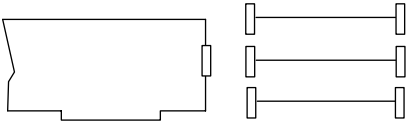

FC 2700 (4-Port Multiprotocol Communications Controller)

The following figure illustrates the 4-Port Multiprotocol Communications Controller with the 4-Port Multiprotocol Interface Cable and attachment cables. The interface cable ports are labeled 0, 1, 3, and 2. Only one interface and associated cable can be selected per port. In order to make the necessary connections to this adapter, your setup person needs to know the type of network interface assigned to each port.

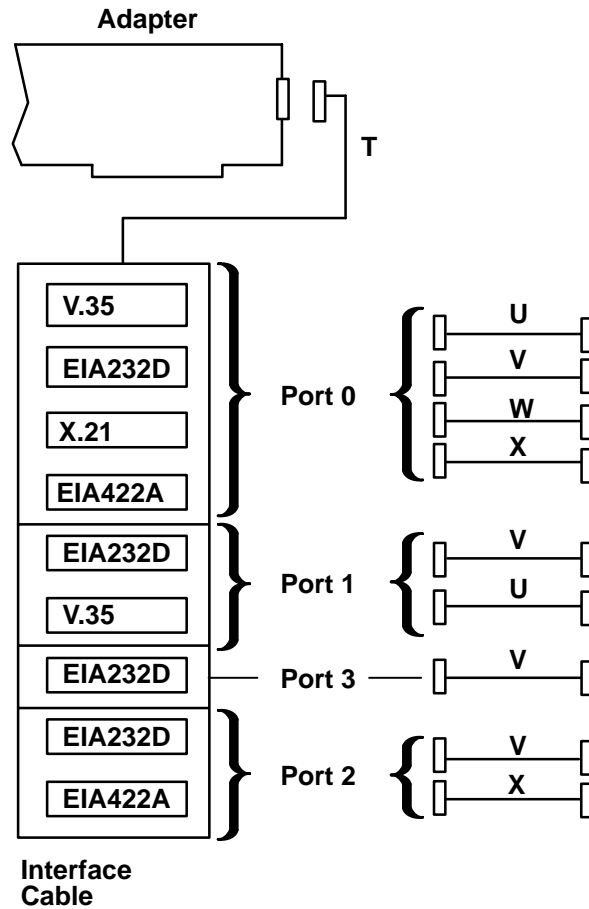

Cable Letter	Cable Name/Description	Part Number	Feature Code	Length m ft
T	Interface/Breakout Box	53F2622/ 40F9897	2705	3 10
U	V.35 cable, if customer-supplied, must meet V.35 requirements	71F0162	2702	2 6.5
V	EIA-232D/V.24 cable, if customer-supplied, must meet EIA-232D/V.24 requirements	71F0165	2706	3 10
W	X.21 cable, if customer-supplied, must meet X.21 cable requirements	71F0164	2704	3 10
X	If customer-supplied, must meet EIA-422A requirements	N/A	N/A	N/A

FC 7002, 7004 Realtime Interface Co-Processor Multiport/2 Adapter/A Configurations

The Realtime Interface Co-Processor Multiport/2 Adapter/A must be used with an Electronic Interface Board and the appropriate device interface breakout box (cable). The following sections illustrate the configurations of the Realtime Interface Co-processor Multiport/2 Adapter/A with an Electronic Interface Board (EIB) and device interface breakout box and cable.

4-Port EIA-232-C Multiport/2 Co-Processor Adapter (FC 7022)

The following figure illustrates the Realtime Interface Co-Processor Multiport/2 Adapter/A with the 4-Port EIA-232-C EIB (FC 7022) attached to a device interface breakout box (cable):

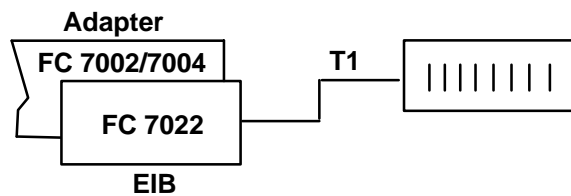

Cable Letter	Cable Name/Description	Part Number	Feature Code	Length m ft
T1	4/8-Port 232/422 Multiport/2 device interface breakout box (cable)	00F5531	7102	3 10

6-Port Synchronous EIA-232-C Multiport/2 Co-Processor Adapter (FC 7024)

The following figure illustrates the Realtime Interface Co-processor Multiport/2 Adapter/A with the 6-Port Synchronous EIA-232-C EIB (FC 7024) attached to a device interface breakout box (cable):

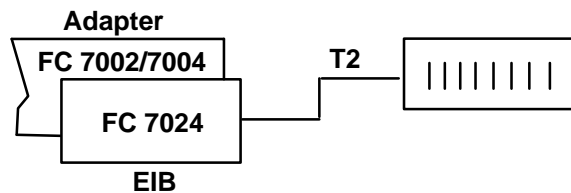

Cable Letter	Cable Name/Description	Part Number	Feature Code	Length m ft
T2	6-Port Sync device interface breakout box with Multiport/2 Cable	05F2028	7104	3 10

8-Port EIA-232-C Multiport/2 Co-Processor Adapter (FC 7026)

The following figure illustrates the Realtime Interface Co-Processor Multiport/2 Adapter/A with the 8-Port EIA-232C EIB (FC 7026) attached to a device interface breakout box (cable):

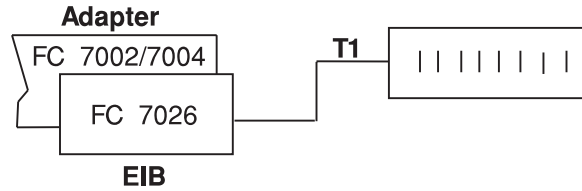

Cable Letter	Cable Name/Description	Part Number	Feature Code	Length	
				m	ft
T1	4/8-Port 232/422 Multiport/2 device interface breakout box (Cable)	00F5531	7102	3	10

4-Port EIA-232-C/4-Port EIA-422A Multiport/2 Co-Processor Adapter (FC 7030)

The following figure illustrates the Realtime Interface Co-Processor Multiport/2 Adapter/A with the 4-Port EIA-232C/4-Port EIA-422A EIB (FC 7030) attached to a device interface breakout box (cable):

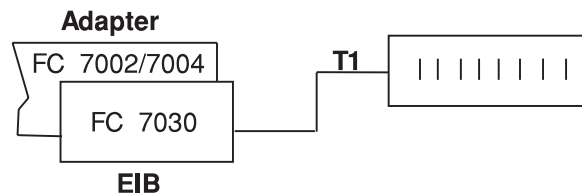

Cable Letter	Cable Name/Description	Part Number	Feature Code	Length	
				m	ft
T1	4/8-Port 232/422 Multiport/2 device interface breakout box (cable)	00F5531	7102	3	10

8-Port EIA-422-A Multiport/2 Co-Processor Adapter (FC 7028)

The following figure illustrates the Realtime Interface Co-Processor Multiport/2 Adapter/A with the 8-Port EIA-422-A EIB (FC 7028) attached to a device interface breakout box (cable):

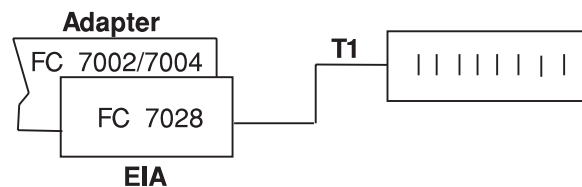

Cable Letter	Cable Name/Description	Part Number	Feature Code	Length m ft
T1	4/8-Port 232/422 Multiport/2 device interface breakout box (cable)	00F5531	7102	3 10

FC 7006, 7008 Realtime Interface Co-Processor Portmaster Adapter/A Configurations

The Realtime Interface Co-Processor Portmaster Adapter/A must be used with an Electronic Interface Board and the appropriate device interface breakout box (cable). The following sections illustrate the configurations of the Realtime Interface Co-processor Portmaster Adapter/A with an Electronic Interface Board (EIB) and device interface breakout box and cable.

8-Port EIA-232-D Portmaster Adapter (FC 7042)

The following figure illustrates the Realtime Interface Co-Processor Portmaster Adapter/A with the 8-Port EIA-232-D EIB (FC 7042) attached to a device interface breakout box (cable):

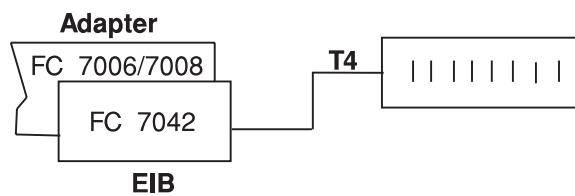

Cable Letter	Cable Name/Description	Part Number	Feature Code	Length m ft
T4	8-Port 232/422 Portmaster device interface box (cable)	53F2619	7108	1.2 4

8-Port EIA-422-A Portmaster Adapter (FC 7044)

The following figure illustrates the Realtime Interface Co-Processor Portmaster Adapter/A with the 8-Port EIA-422-A EIB (FC 7044) attached to a device interface breakout box (cable):

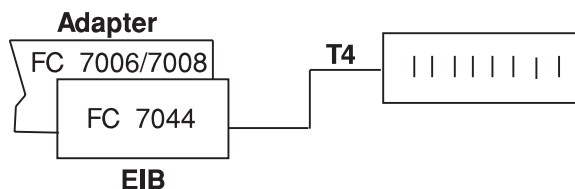

Cable Letter	Cable Name/Description	Part Number	Feature Code	Length m ft
T4	8-Port 232/422 Portmaster device interface breakout box (cable)	53F2619	7108	1.2 4

6-Port V.35 Portmaster Adapter (FC 7046)

The following figure illustrates the Realtime Interface Co-Processor Portmaster Adapter/A with the 6-Port V.35 EIB (FC 7046) attached to a device interface breakout box (cable):

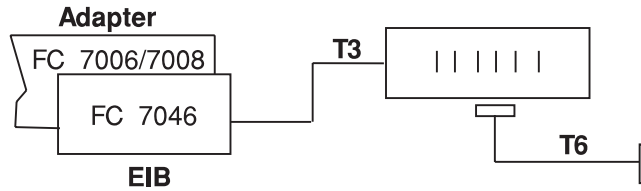

Cable Letter	Cable Name/Description	Part Number	Feature Code	Length m ft
T3	6-Port V.35 Portmaster with device interface breakout box (cable)	72F0165	7106	1.2 4
T6	6-Port V.35 Network Attachment (cable)	11H4958	7107	2 6.5

6-Port X.21 Portmaster Adapter (7048)

The following figure illustrates the Realtime Interface Co-Processor Portmaster Adapter/A with the 6-Port X.21 EIB (FC 7048) attached to a device interface breakout box (cable):

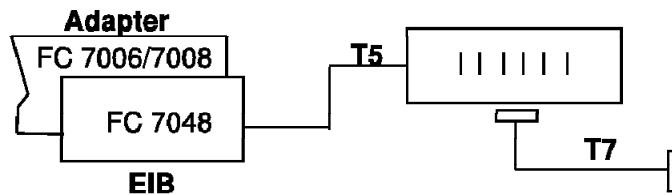

Cable Letter	Cable Name/Description	Part Number	Feature Code	Length m ft
T5	6-Port X.21 Portmaster with device interface breakout box (cable)	05F2028	7110	1.2 4
T7	6-Port X.21 Network Attachment (cable)	11H4957	7111	2 6.5

FC 2970 (Token-Ring High-Performance Network Adapter)

Considerations for Token-Ring applications are found in the following:

- IEEE 802.5 requirements
- *Token-Ring Network Introduction and Planning Guide (GA27-3677)*
- *A Building Planning Guide for Communication Wiring (G320-8059)*
- *Cabling System Planning and Installation Guide (GA27-3361)*
- *Using the Cabling System with Communication Products (GA27-3620).*

The following figure illustrates the Token-Ring High-Performance Network Adapter with an attachment cable for the Token-Ring LAN (Local Area Network). In order to make the necessary connections to this adapter, your setup person needs to know the devices and persons assigned to each port.

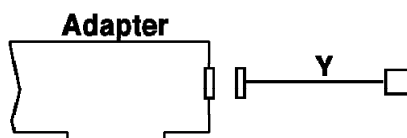

Cable Letter	Cable Name/Description	Part Number	Feature Code	Length	
				m	ft
Y	Token-Ring LAN cable, (shipped with the adapter)	6339098	N/A	3	10
		53F3930	N/A	6	20

FC 2972 (Auto Token-Ring LANstreamer MC 32 Adapter)

Considerations for Token-Ring applications are found in the following:

- IEEE 802.5 requirements
- *Token-Ring Network Introduction and Planning Guide (GA27-3677)*
- *A Building Planning Guide for Communication Wiring (G320-8059)*
- *Cabling System Planning and Installation Guide (GA27-3361)*
- *Using the Cabling System with Communication Products (GA27-3620).*

The following figure illustrates the Auto Token-Ring LANstreamer MC 32 Adapter with an attachment cable for the Token-Ring LAN.

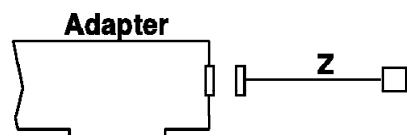

Cable Letter	Cable Name/Description	Part Number	Feature Code	Length	
				m	ft
Z	12-inch Conversion Cable (shipped with the adapter), converts from a 9 pin D-shell to an RJ-45 connector 10-foot data to RJ-45 cable (available)	60G1066	N/A	.3	1
		60G1063	N/A	3.04	10

Integrated Ethernet LAN Adapters

Ethernet cabling varies dependant on the type of system unit you have.

7010 Xstations Ethernet

The 7010 Model 140 and Model 150 integrated Ethernet provides attachments to 10BASE5 (AUI), 10BASE2 (BNC), and 10BaseT (twisted-pair) Ethernet. Twisted-pair Ethernet is achieved by connecting the 10BaseT (twisted-pair) converter directly into the 15 pin D-shell AUI Ethernet port. When connecting to an external transceiver (AA or MM), a block of (7) jumpers on the Xstation planar must be switched.

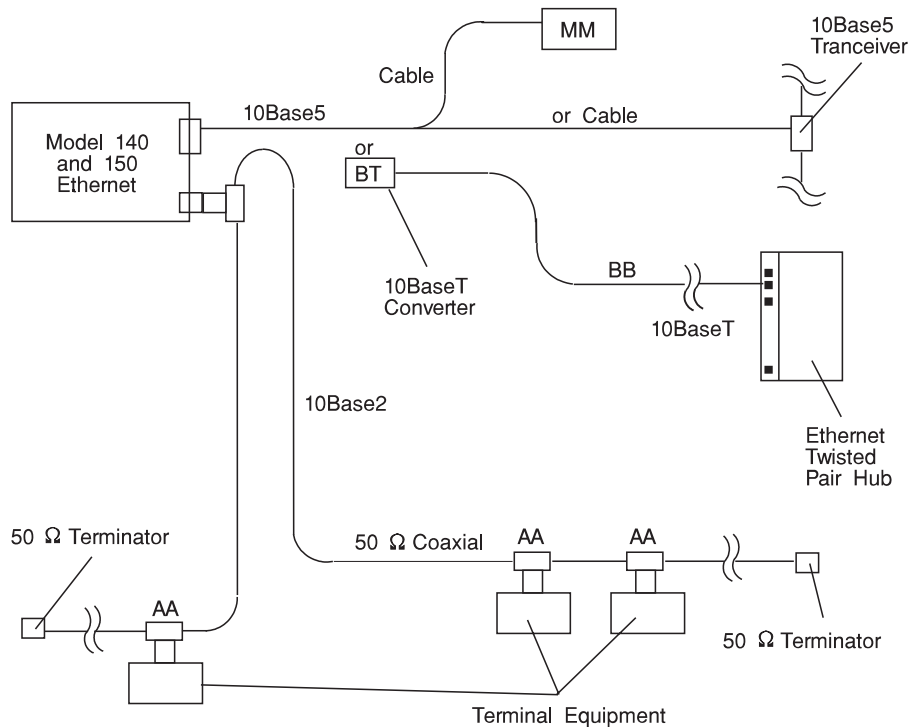

Cable Letter	Cable Name/Description	Part Number	Feature Code	Length m ft
AA	A coaxial "T" connector, "Y-" or "L-" shaped, is recommended	N/A	N/A	N/A
BB	Customer-supplied RJ-45 unshielded twisted-pair cable, must meet IEEE 802.3 requirements	N/A	N/A	N/A
BT	10BaseT Converter (Shipped with Xstation from the factory)	43G2820	N/A	N/A
MM	Ethernet 10Base2 Transceiver or Ethernet 10BaseT Transceiver (feature code includes cable)	02G7435	4223	1 3
		02G7429	4224	1 3

Cable Letter	Cable Name/Description	Part Number	Feature Code	Length m ft
AA	A coaxial "T" connector, "Y-" or "L-" shaped, is recommended	N/A	N/A	N/A
BB	Customer-supplied RJ-45 unshielded twisted-pair cable, must meet IEEE 802.3 requirements	N/A	N/A	N/A
MM	Ethernet 10BaseT Transceiver (feature code includes cable)	02G7429	4224	1 3

Models 250, 41T, 41W, 42T, and 42W Integrated Ethernet LAN Adapter

The Models 250, 41T, 41W, 42T and, 42W have integrated Ethernet thick and twisted pair. Twisted-pair Ethernet is achieved by connecting the 10BaseT (twisted-pair) converter directly into the 15 pin D-shell AUI Ethernet port. Transceivers must be ordered for use with Ethernet Thin (10base2). The following are examples of 10Base2, and 10Base5:**Note:** n is a maxi

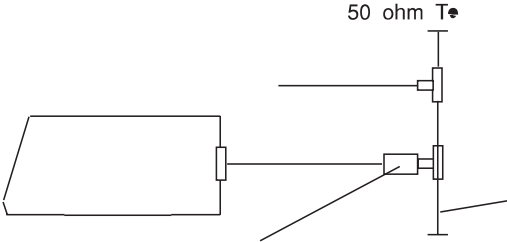

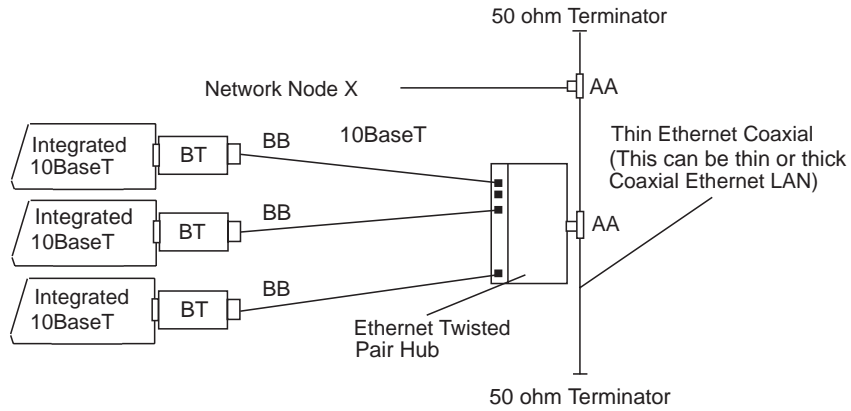

Cable Letter	Cable Name/Description	Part Number	Feature Code	Length m ft
AA	A coaxial "T" connector, "Y-" or "L-" shaped, is recommended	N/A	N/A	N/A
BB	Customer-supplied RJ-45 unshielded twisted-pair cable, must meet IEEE 802.3 requirements	N/A	N/A	N/A
MM	Ethernet 10BaseT Transceiver (feature code includes cable)	02G7429	4224	1 3
BT	10BaseT Converter (Shipped with system from the factory)	51G8479	N/A	N/A

Models 34H, 350, 360, 370, 380, 390, 39H, 3AT, 3BT and 3CT Integrated Ethernet LAN Adapter

The integrated Ethernet adapter features thick and thin connectors (FC 4221) or twisted-pair (FC 4222). The thick connector is an Ethernet standard connector.

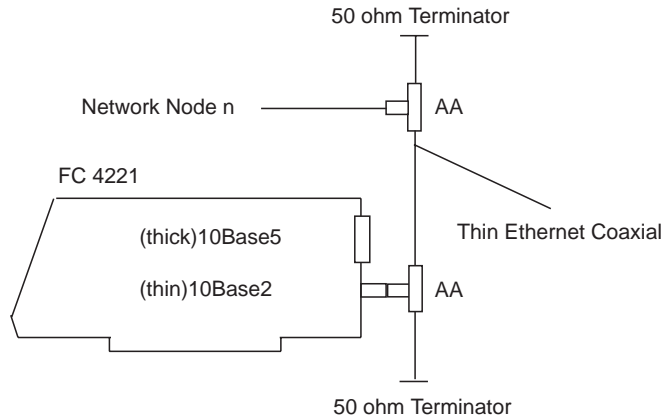

Note: n is a maximum of 30 nodes per segment (maximum of five segments with each segment connected by a repeater).

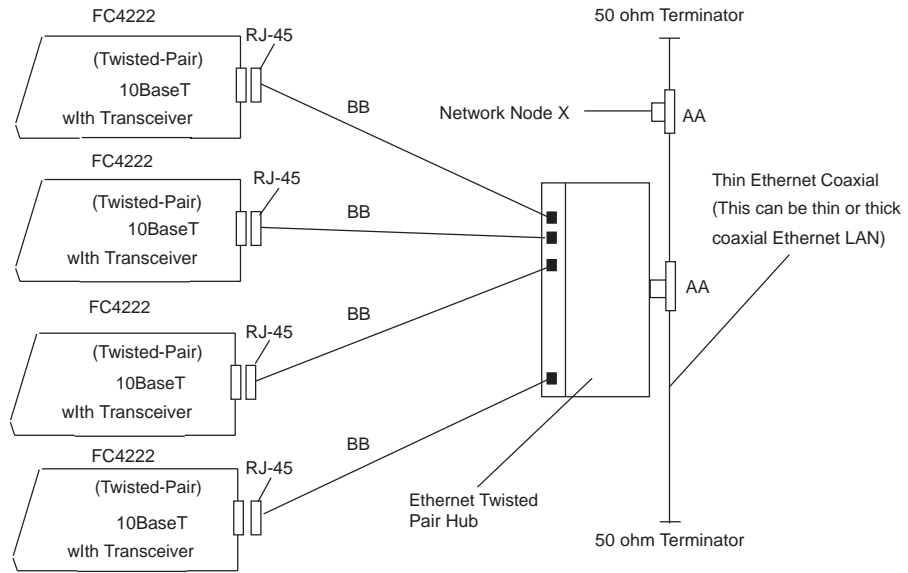

Cable Letter	Cable Name/Description	Part Number	Feature Code	Length m ft
AA	A coaxial "T" connector, "Y-" or "L-" shaped, is recommended	N/A	N/A	N/A
BB	Customer-supplied RJ-45 unshielded twisted-pair cable, must meet IEEE 802.3 requirements	N/A	N/A	N/A

FC 2980 (Ethernet High-Performance LAN Adapter)

The following figure illustrates the Ethernet High-Performance LAN Adapter with attachment cables. The thick connector is an Ethernet standard connector.

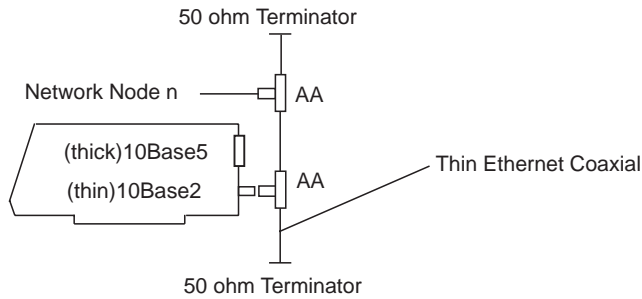

Note: n is a maximum of 30 nodes per segment (maximum of five segments with each segment connected by a repeater).

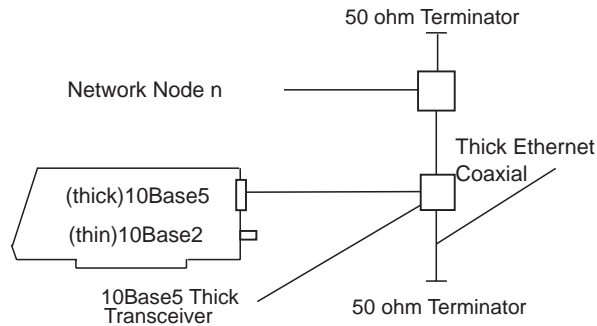

Note: n is a maximum of 100 nodes per segment (maximum of 5 segments with each segment connected by a repeater).

Cable Letter	Cable Name/Description	Part Number	Feature Code	Length m ft
AA	A coaxial "T" connector, "Y-" or "L-" shaped, is recommended	N/A	N/A	N/A

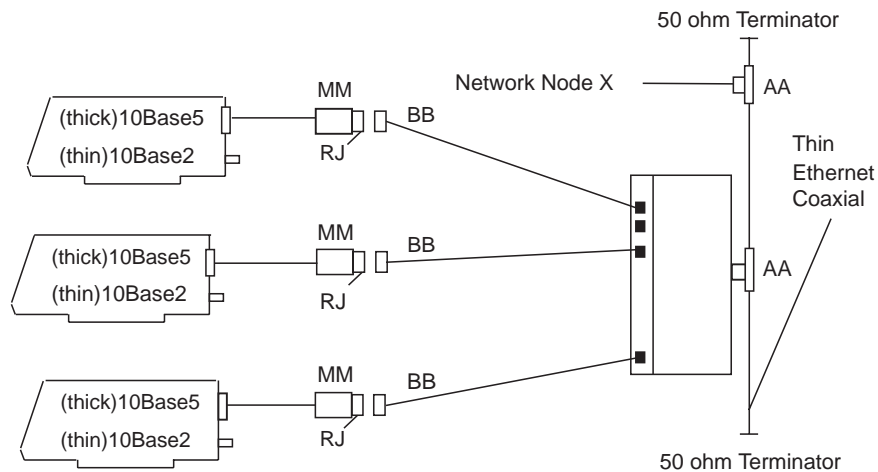

Cable Letter	Cable Name/Description	Part Number	Feature Code	Length m ft
AA	A coaxial "T" connector, "Y-" or "L-" shaped, is recommended	N/A	N/A	N/A
BB	Customer-supplied RJ-45 unshielded twisted-pair cable, must meet IEEE 802.3 requirements	N/A	N/A	N/A
MM	Ethernet 10Base-T Transceiver (feature code includes cable)	02G7429	4224	1 3

FC 2984, 2989 (TURBOWAYS 100 and 155 ATM Adapter)

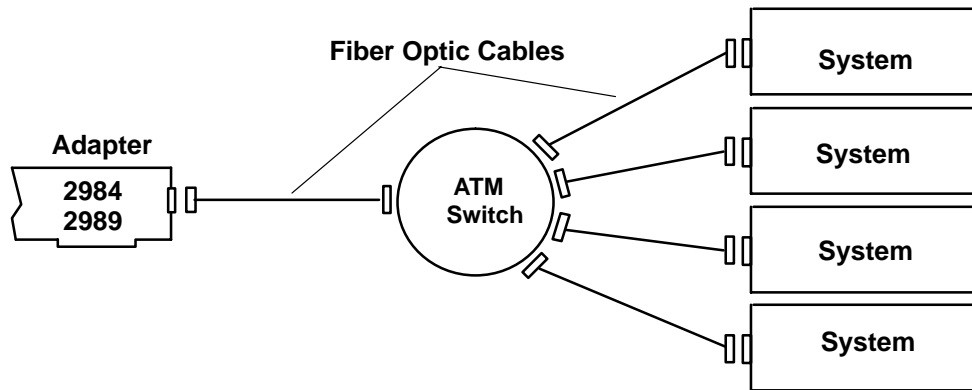

Cable Considerations

Fiber Channel cabling is required and must be ordered separately. Orders can be placed using an MES. For standard cable lengths and part numbers, see the chart below. Custom lengths are also available.

Cable Name/Description	Length		Part Number 62.5/125 Multimode
	m	ft	
Fiber Optic Cable	2	6.6	19G6706
	4	13	19G4864
	6	20	19G4865
	10	33	19G4866
	20	66	19G4867
	40	131	19G4868
	Custom		19G4863

Optical ports may also be connected by 62.5/125 micron multimode fiber, terminated with industry standard SC connectors. The maximum length between the optical port on the adapter and the switch is 0.7 kilometers with the 62.5/125 micron fiber.

FC 2990 (3270 Connection Adapter)

The following figure illustrates the 3270 Connection Adapter with attachment cable.

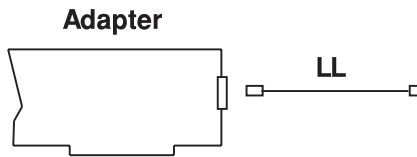

Cable Letter	Cable Name/Description	Part Number	Feature Code	Length m ft
LL	Customer-supplied coaxial cable	6245998	N/A	3 10

FC 2800 (System/370 Host Interface Adapter)

There are a variety of ways to cable the System/370 Host Interface Adapter to the 5088 or the 6098 Graphics Control Units.

The System/370 Host Interface Adapter and the 5080 Attachment Adapter are the same physical adapter. The way the adapter is cabled and the microcode loaded in the adapter changes the function. See the *5080 Graphics System Installation, Operation, and Problem Determination* manual, form number GA23-2063 for information about the various configurations using the host interface adapter and 5080 attachment adapter.

The host interface adapter has an HIA label on it. It connects the system to a 5088 or 6098 Controller. The adapter can pass the signal on to other systems.

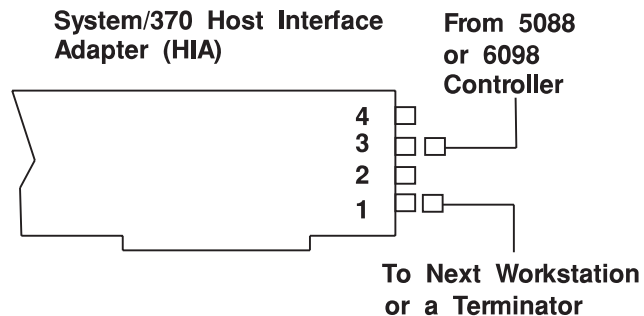

System 971

FC 2720, 2722, 2723, and 2724 (Adapters) Fiber

All FDDI-Fiber adapters require fiber cables are a customer responsibility. The design or installation of FDDI-Fiber requires form number GA27-3892. For more information on planning, see the *FDDI Optical Fiber Planning* and *FDDI Adapter User's Guide and*

The various FDDI adapter types can be used in a single ring configuration or a dual ring configuration. The single ring configuration provides a single point of failure. The dual ring configuration provides a point of failure and can be reconfigured to maintain network connectivity.

The following figure illustrates the FDDI-Fiber adapter configurations. The FC 2720 and 2724 are for the base card only. The FC 2722 and 2723 are for the FDDI dual-ring upgrade kit.

2720 or 2724 FDDI Fiber
Base Adapter Single-Ring
Attach

FDDI

PP

2723
Attach

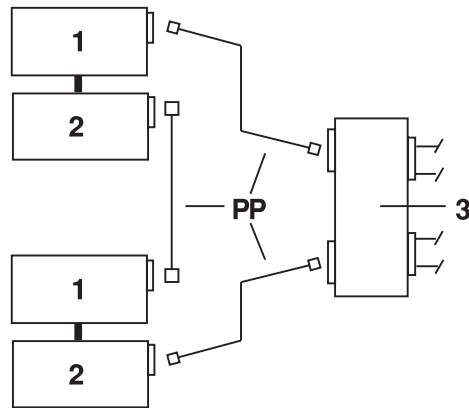

Dual Ring Configuration

Cable Letter	Cable Name/Description	Part Number	Feature Code	Length m ft
PP	<p>All FDDI Fiber Adapters require multi-mode FDDI optical fiber jumper cables.</p> <p>Jumper cables are the responsibility of the customer and can be ordered from the local cabling distributor.</p> <p>For installation of FDDI systems, refer to publication <i>FDDI Introduction and Planning Guide</i>, GA27-3892.</p> <p>For additional information concerning FDDI optical systems, refer to publication <i>FDDI Optical Fiber Planning and Installation Guide</i>, GA27-3943.</p>	N/A	N/A	N/A
1	FDDI Fiber Base Adapter Single-Ring Attach	N/A	2720 or 2724	N/A
2	FDDI Fiber Dual-Ring Attach	N/A	2722 or 2723	N/A
3	Concentrator	N/A	N/A	N/A

FC 2725 and 2726 Shielded Twisted-Pair (STP) FDDI Adapter

All FDDI-STP adapters require shielded twisted pair copper jumper cables. Jumper cables are a customer responsibility and may be ordered from authorized cabling distributors. For more information about jumper cables, planning, design or installation of FDDI systems, refer to *FDDI Introduction and Planning Guide*, order number GA27-3892. For more information regarding FDDI optical systems, refer to *FDDI Optical Fiber Planning and Installation Guide*, order number GA27-3943.

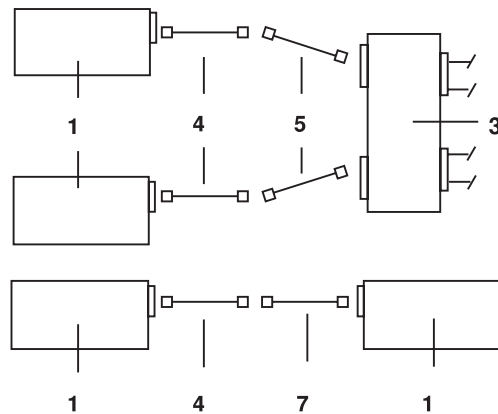

Item Number	Cable Letter	FRU Number	Description
1	N/A	65G1878	FDDI-STP (Type 2-T) single ring adapter
3	N/A	N/A	Concentrator
4	FB	33G2761	FDDI-STP adapter cable
5	FC	33G2760	FDDI-STP - FDDI-STP transition cable
7	FA	33G2762	FDDI-STP reversing cable

Note: The part numbers in the table above are controlled by Mechanicsburg.

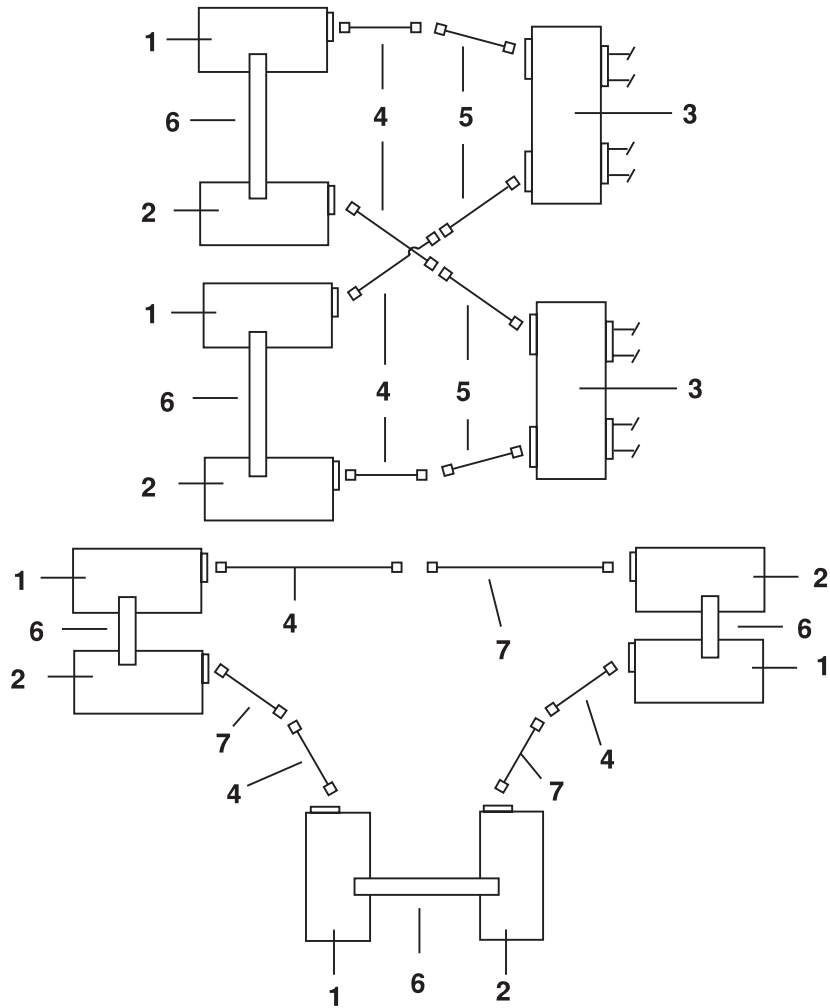

Item Number	Cable Letter	FRU Number	Description
1	N/A	65G1878	FDDI-STP (Type 2-T) single ring adapter
2	N/A	43G0876	FDDI-STP (Type 2-U) dual ring upgrade kit adapter
3	N/A	N/A	Concentrator
4	FB	33G2761	FDDI-STP adapter cable
5	FC	33G2760	FDDI-STP - FDDI-STP transition cable
6	N/A	93F1162	FDDI-STP dual ring upgrade kit crossover cable
7	FA	33G2762	FDDI-STP reversing cable

Note: The part numbers in the table above are controlled by Mechanicsburg.

Cable FA - FDDI Copper Adapter Reversing Cable				
Adapter Card D Connector Pin	Wire Number	Wire Color	Data Connector Pin	Usage
Shield (ground)	1	Shield	Shield (ground)	Ground
1	3	Black	Black	Receive +
5	4	Red	Red	Transmit +
6	2	Orange	Orange	Receive -
9	5	Green	Green	Transmit -

Cable FB - FDDI Copper Adapter Cable				
Adapter Card D Connector Pin	Wire Number	Wire Color	Data Connector Pin	Usage
Shield (ground)	1	Shield	Shield (ground)	Ground
5	3	Black	Black	Receive +
1	4	Red	Red	Transmit +
9	2	Orange	Orange	Receive -
6	5	Green	Green	Transmit -

FC 2860 (Serial Optical Channel Converter)

The following figure illustrates the Serial Optical Channel Converter with an attachment cable.

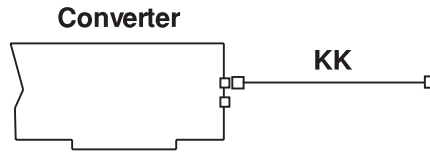

Cable Letter	Cable Name/Description	Part Number	Feature Code	Length	
				m	ft
KK	Optical Channel Converter Cable	46F2440	2866	6	20
		46F2441	2867	10	33
		46F2442	2868	20	65.5
		46F2443	2869	60	197
		46F2444	2870	100	328

FC 2402 and 2403 (Network Terminal Accelerator Adapters)

10Base-T Cabling

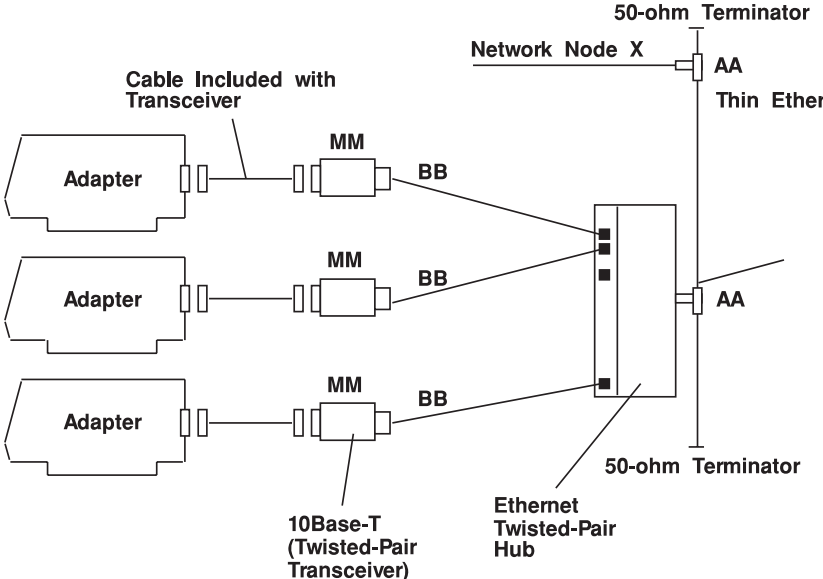

10Base-2 Cabling

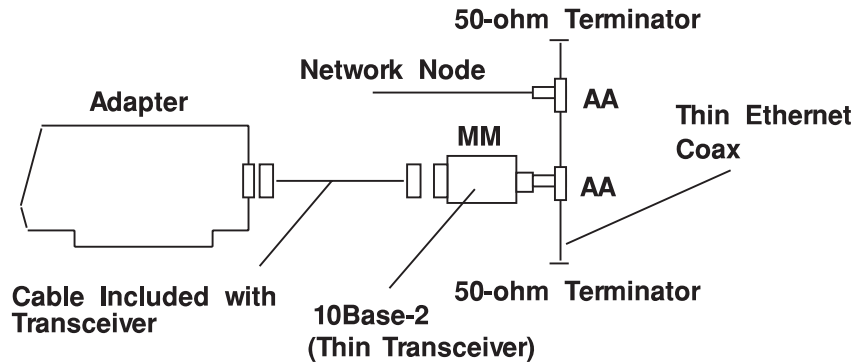

Note: n is a maximum of 30 nodes per segment (maximum of 5 segments connected by a repeater).

Cable Letter	Cable Name/Description	Part Number	Feature Code	Length m ft
AA	Customer-supplied coaxial T-connector, Y- or L-shaped is recommended.	N/A	N/A	N/A
MM	Ethernet 10Base-2 transceiver Cable (feature code includes cable)	02G7435	4223	1 3

10Base-5 Cabling

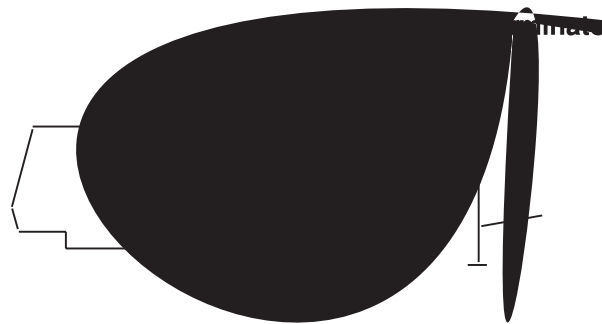

FC 1904/1902 (Fibre Channel Adapter 1063)

This Fibre Channel Switch has a maximum of 16 ports. The switch operates at 1063 mega-bits per second. Feature code 1902 is for the optical driver.

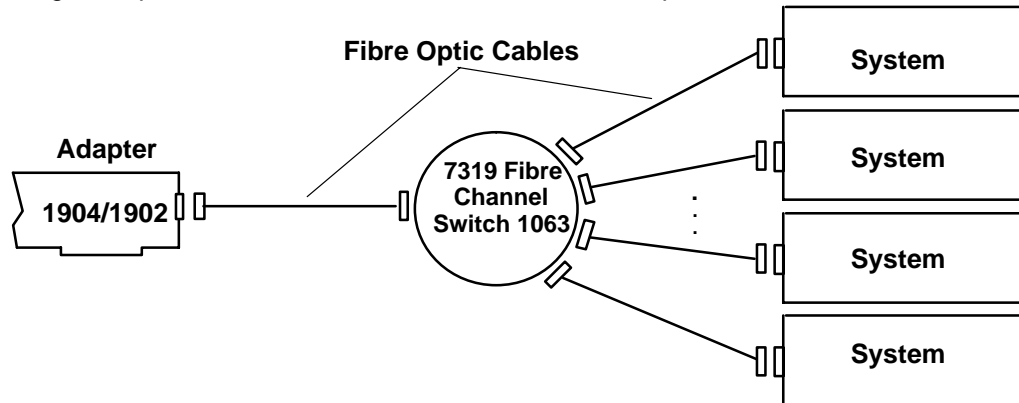

Cable Considerations

Fibre Channel cabling is required and must be ordered separately. Orders for cables can be placed through MES. For standard cable lengths and part numbers, see the chart below.

Cable Name	Length		Part Number * Multi-mode
	m	ft	
Fibre Optic Cable	7	22	54G3384/54G3385
	13	42	54G3384/54G3386
	22	72	54G3384/54G3387
	31	101	54G3384/54G3388
	46	150	54G3384/54G3389
	61	200	54G3384/54G3390
	Custom		54G3384/54G3391

Note: * There are two part numbers in the table. The first is for ordering cables in the United States. The second is for ordering cables in other countries.

Optical ports are connected with 50/125 multi-mode Fibre and terminated with industry-standard SC connectors.

Multi-mode

- 50 Micron Fibre
- Short Wave - 680 nanometers wave length

Full Speed

- 1063 mega-bits per second
- Up to 500 meters cable length

FC 1906 (Fibre Channel Adapter/266)

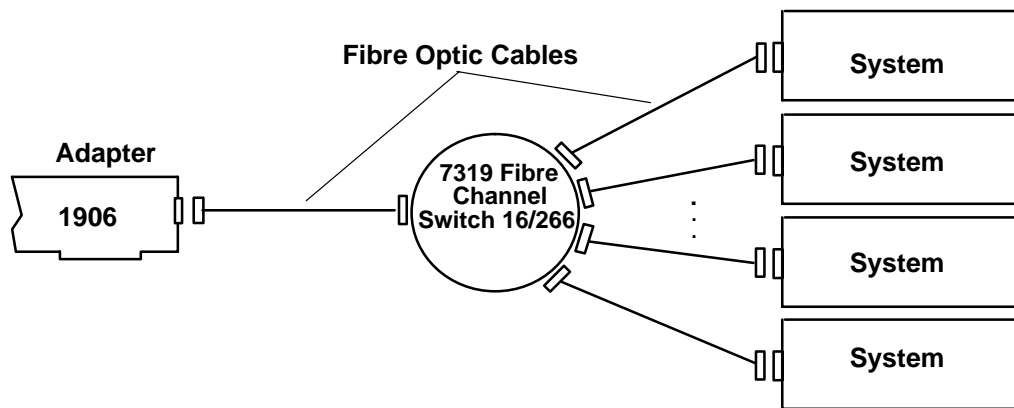

Cable Considerations

Fibre Channel cabling is required and must be ordered separately. Some specific lengths are available. Custom lengths and cable accessories are also available.

Cable Name/ Description	Length		Part Number 50/125 Multimode	Part Number 62.5/125 Multimode
	m	ft		
Fiber Optic Cable	2	6.6	NA	19G6706
	4	13	19G4772	19G4864
	6	20	19G4773	19G4865
	10	33	19G4774	19G4866
	20	66	19G4775	19G4867
	40	131	19G4776	19G4868
	60	197	19G4777	NA
	80	262	19G4778	NA
	100	328	19G4799	NA
	Custom		NA	19G4863

Optical ports may also be connected by either 50/125 (recommended) or 62.5/125 micron multimode fiber, terminated with SC connectors (industry-standard connectors). The maximum length between the optical port on the adapter and the switch is 2 kilometers with the 50/125 micron cables and 0.7 kilometers with the 62.5/125 micron fiber.

Channel Attachment Adapter Cabling

This section provides information on cabling for channel attached devices.

FC 2755 (Block Multiplexer Channel Adapter)

Establishing communications with an S/370 or S/390 host requires special planning. Cabling, hardware, and software considerations are discussed below. For more detailed information on planning for, installing, and operating the adapter, refer to the *Block Multiplexer Channel Adapter User's Guide and Service Information*, order number SC23-2427.

Cable Considerations

The cable and cable assembly in the following figure are separately orderable. Use of the specified cable and cable assembly is recommended due to the critical cabling specifications required for your systems connection to the host.

To order the cables necessary to attach the cable assembly to the host, contact your marketing representative. Keep the following in mind when ordering:

Notes:

1. Blue channel cables must be used if the adapter is to be operated at 4.5MB or if the 3044 Model 2 Channel Extender is used.
2. Cables (bus and tag) must be used in pairs of equal length and matching color (blue or gray, but not both). Bus and tag cables can be ordered separately and must be ordered to the desired length. The Host Channel Cable group for your system is 0185.
3. There are some cable length limitations. When data streaming mode is used, there can be no more than 122 m (400 ft) between the system unit and the host. If there are other channel-attached devices located between the system unit and the host, deduct 4.5 m (15 ft) for each device in your cable measurement. Some devices may require additional cable length calculations; consult your *System/360, System/370, 4300, 9370 and ES9000 Processors Input Output Equipment Installation Manual-Physical Planning*, order number GC22-7064, for the particular device.
4. The system unit can connect to a 3044 Model 002 Channel Extender, which allows the System/370 parallel channel to be extended up to 3 km (1.9 miles). It can also connect to a 9034 Model 1 ESCON Converter, which allows communications with a System/370 or System/390 ESCON channel. There can be up to 3 km (1.9 miles) between the 9034 and the host.

Adapters to Single Channel



Hardware Considerations

- The remote power interface as described in *System/360 and System/370 Power-Control Interface Original Equipment Manufacturers' Information*, order number GA22-6906, is not supported on the system.
- The processors supported by the Block Multiplexer Channel Adapter are summarized below. Certain processors can use the 9034 Model 1 ESCON Converter or the 3044 Model 2 Channel Extender. Connection to an ESCON channel requires a 9034 Model 1. You cannot use both a 9034 and a 3044 on the same channel.

System Processor	Channel Type	Speed
9021	Parallel	Up to 4.5MB
9021	ESCON*	Up to 4.5MB
9121	Parallel	Up to 4.5MB
9121	ESCON*	Up to 4.5MB
9221	Parallel	Up to 4.5MB
9221	ESCON*	Up to 4.5MB
ES/3090	Parallel	Up to 4.5MB
ES/3090 (J)	ESCON*	Up to 4.5MB
308X	Parallel	Up to 3.0MB
4381	Parallel	Up to 3.0MB

* Requires use of the 9034 Model 1 ESCON Converter.

- The Block Multiplexer Channel Adapter supports three speeds. The type of processor channel used depends on the speed setting.

Speed Setting	Channel Speed	Processor Channel
0	DCI	Any
2	2.7MB (maximum)	3MB
4	4.5MB (maximum)	4.5MB

Software Considerations

Consider the following when planning for the Block Multiplexer Channel Adapter:

- AIX Version 3.2 or later is required for your system. Adapter channel addresses and speed are set up using SMIT.
- The System/390 host I/O control program (IOCP) must be updated to include your system. The system is defined as a 3088.
- The System/390 host operating systems must be updated to recognize and support your system unit.

FC 2756 (System/390 ESCON Control Unit Adapter)

Establishing communications with a System/390 host requires special planning. Cabling, hardware, and software considerations are discussed below. For more detailed information on planning for, installing, and operating the adapter, refer to the *Enterprise System Connection Adapter User's Guide and Service Information*, order number SC23-2474.

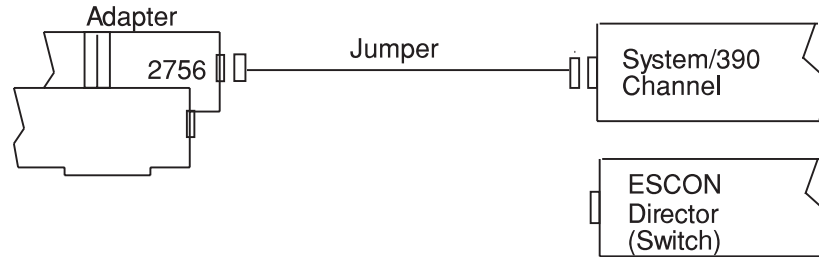

Note: The ESCON jumper cable can connect to any ESCON channel, trunk, or ESCON director.

Cable Considerations

ESCON jumper cables may be ordered separately.

To order the cable necessary to attach to the host, contact your marketing representative. The following table lists the standard ESCON duplex-to-duplex jumper cable part numbers.

Cable Name/Description	Part Number	Length	
		m	ft
System/390 ESCON Channel Jumper Cable (Duplex-to-Duplex)	74F5412	3.7	12
	74F5413	6.1	20
	74F5414	12.1	40
	74F5415	21.3	70
	74F5416	30.4	100
	74F5417	61	200
	74F5418	122	400

Refer to Maintenance Information for Enterprise Systems Connection Links, *Fiber optic Link Maintenance*, order number SY27-2597 for additional information.

Hardware Considerations

The processors supported by the System/390 ESCON Channel Adapter are summarized below.

System Processor	Channel Type	Speed
9021	ESCON	Up to 17MB
9121	ESCON	Up to 10MB
9221	ESCON	Up to 10MB
ES/3090 (J)	ESCON	Up to 10MB

Software Considerations

Consider the following when planning for the ESCON channel adapter:

- AIX Version 3.2 or later is required. Adapter channel address and speed are set up using SMIT.
- The System/390 I/O Control Program (IOCP) must be updated to include your system. The IOCP should specify a 3088 device type, or an SCTC (if using HCD).
- The System/390 operating system must be updated to recognize and support your system unit.

FC 2735 (HIPPI Channel Adapter)

The following figure illustrates the HIPPI Channel Adapter set with the attachment cables:

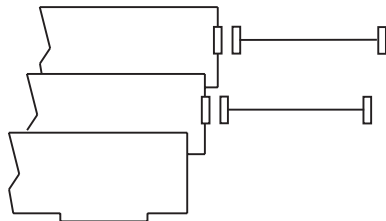

Cable Letter	Cable Name/Description	Part Number	Feature Code	Length m ft
1A	Customer-supplied HIPPI cable, must be HIPPI-compliant with ANSI standard HIPPI-pHX3.183-1991	N/A	N/A	N/A

FC 2759 (S/370 Channel Emulator/A Adapter)

The following figure illustrates the S/370 Channel Emulator/A adapter with an attachment cable (the cable is included with the feature):

Single Adapter to Single Channel

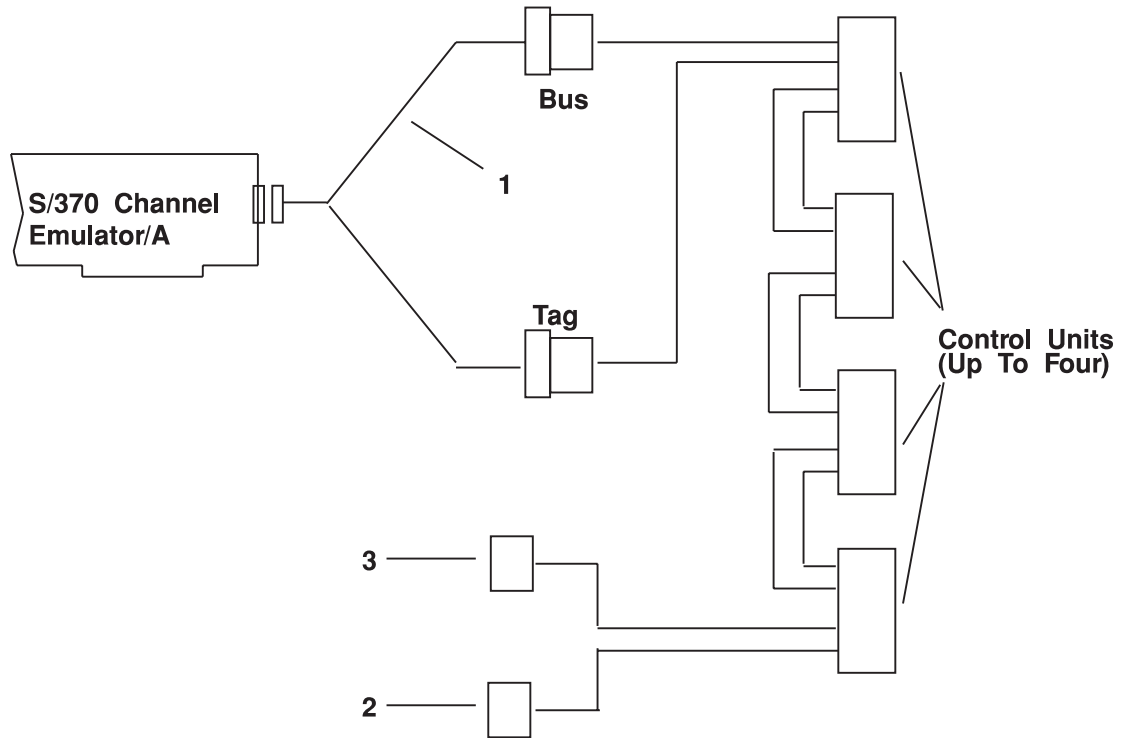

Cable Letter	Cable Name/Description	Part Number	Feature Code	Length	
				m	ft
1	S/370 Channel Emulator/A Cable	68F7209	N/A	3.0	9.8
2	Bus Terminator	2282675	N/A	NA	
3	Tag Terminator	2282676	N/A	NA	

Note: Refer to the *System/360, System/370, 4300, 9370 and ES9000 Processors Input/Output Equipment Installation Manual - Physical Planning*, order number GC22-7064, for details and restrictions regarding channel cabling.

FC 2754 (S/390 ESCON Channel Emulator)

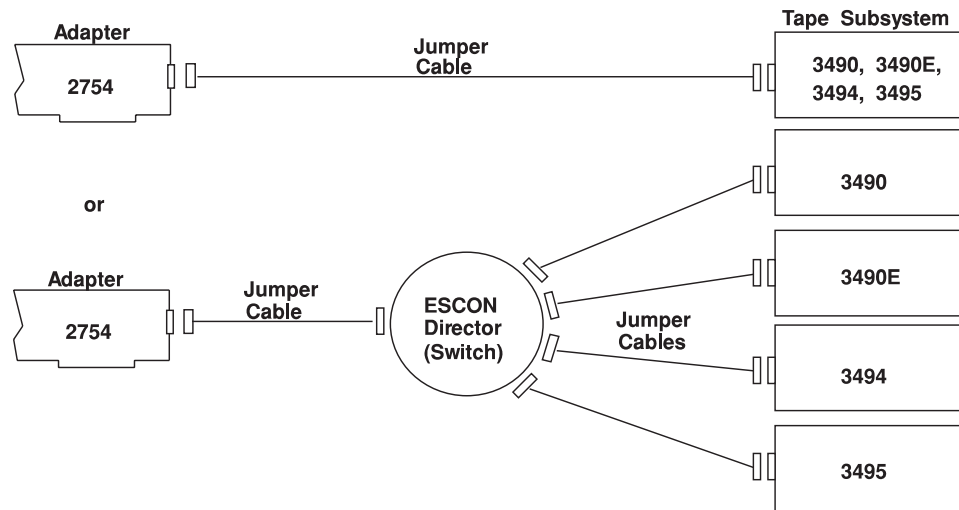

Cable Considerations

ESCON jumper cables may be ordered separately.

To order the cable necessary to attach your system, contact your marketing representative. The following table lists the standard ESCON duplex-to-duplex jumper cable part numbers.

Cable Name/Description	Part Number	Length	
		m	ft
System/390 ESCON Channel Jumper Cable (Duplex-to-Duplex)	74F5412	3.7	12
	74F5413	6.1	20
	74F5414	12.1	40
	74F5415	21.3	70
	74F5416	30.4	100
	74F5417	61	200
	74F5418	122	400

Fiber optical cables for the ESCON Channel Emulator are required and should be ordered separately. For more information about planning for and installing required cables, see Planning for Enterprise System Connection Links in, *ESCON Link Planning section*, order number (GA23-0367).

Software Considerations

Consider the following when planning for the S/390 ESCON Channel Emulator:

- AIX Version 3.2 or later is required.
- Software for tape subsystem support is obtained from Storage Systems Division.

Graphics Adapter Cabling

This section provides information on cabling for graphics adapters. Displays mentioned in this section have the following characteristics:

1. POWERdisplay 17 (features a Trinitron TM1 CRT with a maximum viewable image size of 409 mm (16.1 inches) measured diagonally).
2. POWERdisplay 20 display (features a Trinitron TM CRT with a maximum viewable image size of 486 mm (19.1 inches) measured diagonally).
3. 6091-19i display (features a Trinitron TM CRT that has a fixed image size of 439 mm (17.3 inches) measured diagonally).
4. 1091-051 display (features a Trinitron TM CRT that has a fixed image size of 376 mm (14.8 inches) measured diagonally).

FC 2770 (Color Graphics Display Adapter)

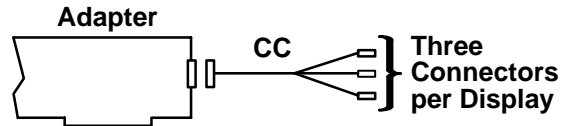

Cable Letter	Cable Name/Description	Part Number	Feature Code	Length m ft
CC	Display adapter cable, contains an integral toroid assembly	58F2903	N/A	2.4 8

FC 4208 and 2803 (POWER Gt1, Gt1b)

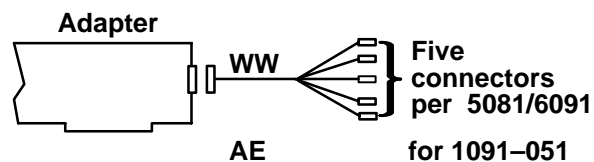

The adapter also supports attachment to some PS/2 displays, with attached cables.

Cable Letter	Cable Name/Description	Part Number	Feature Code	Length m ft
WW	POWER Gt1 Display Adapter Cable, contains an integral toroid assembly.	58F2902	4217	2 6
AE	Gt1 to 1091-051	09G3588	9020	1.83 6

¹ Trademark of Sony Corporation

FC 4207 (POWER Gt1x)

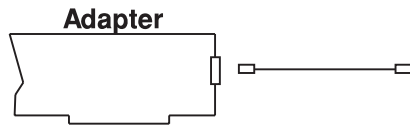

AB (POWERdisplays 16, 17, 19, 20, 5081, 6091)

AC (6314, 6317, 6319, 8508, 8517)

AD POWERdisplay 16s, 1091-051

Cable Letter	Cable Name/Description	Part Number	Feature Code	Length m ft
AB	Gt1x display cable	09G3539	4214	1.83 6
AC	Gt1x display cable	52G3255	4213	0.3 1
AD	Gt1x to 1091-051	09G3589	9021	1.83 6
AD	Gt1x POWERdisplay 16s	09G3589	4229	1.83 6

FC 2768 (POWER Gt4e)

The following figure illustrates the POWER Gt4e with an attachment cable for one display.

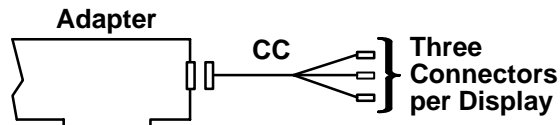

Cable Letter	Cable Name/Description	Part Number	Feature Code	Length m ft
CC	Display adapter cable (contains an integral toroid assembly)	58F2903	N/A	2.4 8

FC 2711 and 2713 (POWER Gt4i and Gt4xi)

The figure below illustrates the POWER Gt4i and Gt4xi with an attachment cable for one display.

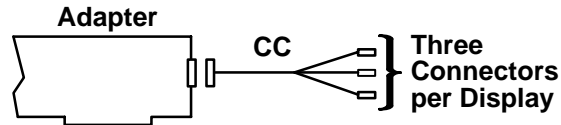

Cable Letter	Cable Name/Description	Part Number	Feature Code	Length m ft
CC	Display adapter cable (contains an integral toroid assembly)	58F2903	N/A	2.4 8

FC 2766 (POWER GXT100 Graphics Adapter)

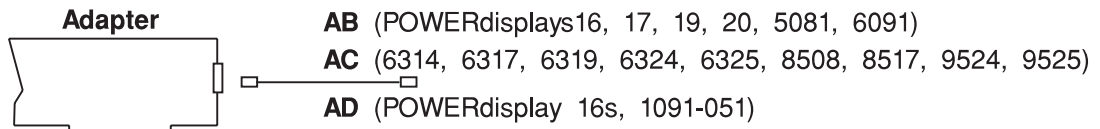

Cable Letter	Cable Name/Description	Part Number	Feature Code	Length m ft
AB	Display cable, 3 BNC connectors	09G3539	4214	1.83 6
AC	Display conversion cable, 13W3 to 15-pin	52G3255	4213	0.3 1
AD	Display cable, 5 BNC connectors	09G3589	4229	1.83 6

FC 2767 (POWER GXT150 Graphics Adapter)

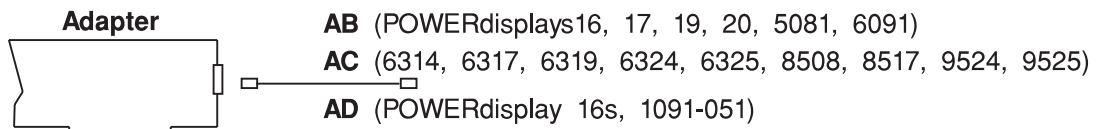

Cable Letter	Cable Name/Description	Part Number	Feature Code	Length m ft
AB	Display cable, 3 BNC connectors	09G3539	4214	1.83 6
AC	Display conversion cable, 13W3 to 15-pin	52G3255	4213	0.3 1
AD	Display cable, 5 BNC connectors	09G3589	4229	1.83 6

FC 2660 (POWER GXT150L Graphics Adapter)

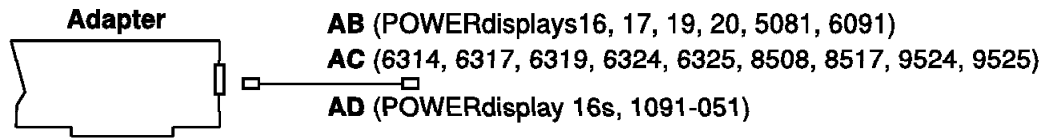

Cable Letter	Cable Name/Description	Part Number	Feature Code	Length	
				m	ft
AB	Display cable, 3 BNC connectors	09G3539	4214	1.83	6
AC	Display conversion cable, 13W3 to 15-pin	52G3255	4213	0.3	1
AD	Display cable, 5 BNC connectors	09G3589	4229	1.83	6

FC 2650 (POWER GXT150M Graphics Adapter)

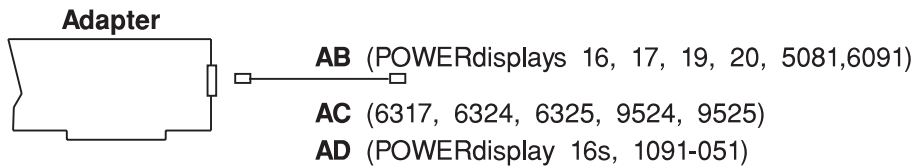

Cable Letter	Cable Name/Description	Part Number	Feature Code	Length	
				m	ft
AB	Display cable, 3 BNC connectors	09G3539	4214	1.83	6
AC	Display conversion cable, 13W3 to 15-pin	52G3255	4213	0.3	1
AD	Display cable, 5 BNC connectors	09G3589	4229	1.83	6

FC 2665 (POWER GXT155L Graphics Adapter)

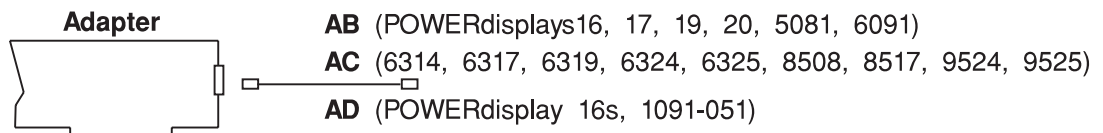

Cable Letter	Cable Name/Description	Part Number	Feature Code	Length	
				m	ft
AB	IptioB Ä- Ä				

FC 2801 and 2802 (5085 or 5086 Attachment Adapters)

The following figure illustrates the 5085 or 5086 Attachment Adapters with an attachment cable for one 5085 or 5086 Graphics Processor.

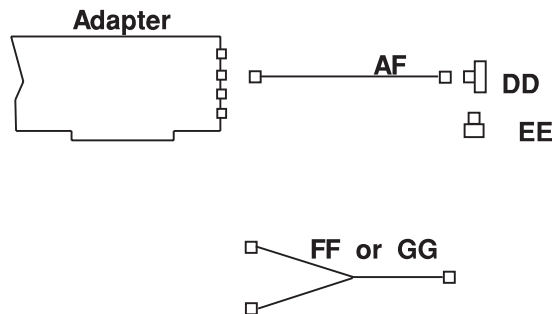

Cable Letter	Cable Name/Description	Part Number	Feature Code	Length m ft
AF	Customer-supplied coaxial cable	6245998	N/A	5 16.4
DD	Coaxial BNC Tee connector	N/A	N/A	N/A
EE	BNC terminator	6246330	N/A	N/A
FF	"Y" cable from 5085 Graphics Processor to system unit	6247042	N/A	5 16.4
GG	"Y" cable from 5086 Graphics Processor to system unit	6247041	N/A	5 16.4

For specific planning and cabling information, refer to the *5080 Graphics System Installation, Operation, and Problem Determination Guide*, order number GA23-2063.

FC 2810 (Graphics Input Device Adapter)

The following figure illustrates the Graphics Input Device Adapter with an attachment cable.

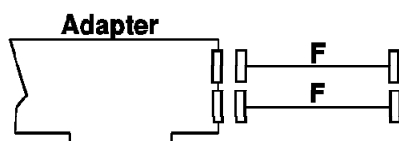

Cable Letter	Cable Name/Description	Part Number	Feature Code	Length m ft
F	Lighted Programmable Function Keyboard, Dials, or Tablet Attachment Cable, supplied with the 6094 Model 10 Dials or the 6094 Lighted Programmable Function Keyboard Model 20	6247480	2811	2.1 7

FC 4350 (7235 Attachment Adapter) POWER GTO Accelerator Adapter

The following figure shows the POWER GTO Accelerator Adapter attached to the 7235 POWER GTO to the system unit.

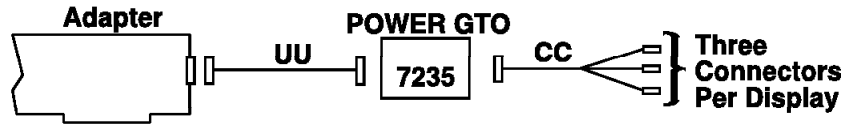

Cable Letter	Cable Name/Description	Part Number	Feature Code	Length	
				m	ft
UU	7235 Signal Cable, used to attach system unit to 7235 (supplied with 7235)	74F3102	N/A	2.0	6.5
CC	Display Adapter Cable, contains an integral toroid assembly (cable supplied with 7235)	58F2903	N/A	2.4	8

FC 2820 (7250 Attachment Adapter) POWER GXT1000 Graphics Accelerator

The following figure shows the POWER GXT1000 Graphics Accelerator Adapter attached to the 7250 POWER GXT1000.

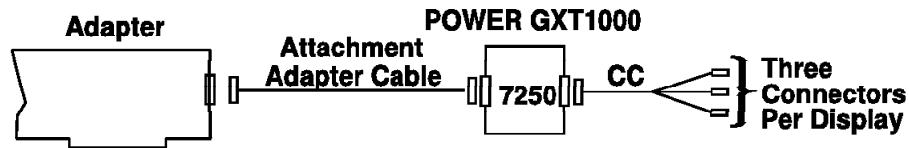

Cable Letter	Cable Name/Description	Part Number	Feature Code	Length	
				m	ft
	Attachment Adapter Cable	19G5935	N/A	2	6.6
CC	Display Adapter Cable, contains an integral toroid assembly	58F2903	N/A	2.4	8

FC 2850 POWER GXT800M 3D Graphics Adapter W/Texture Memory

Display Type	Screen Resolution (Non-Interlaced)	Refresh Freq (Hz)	Adapter Cable Part Number
6091-16 Color POWERdisplay 16	1280 x 1024	60 1 *	39H8683
		77 2	39H8683
6091-19i Color POWERdisplay 19	1280 x 1024	60 3 *	39H8683
		77	39H8683
1091-051 Color POWERdisplay 16S	1280 x 1024	72*	09G3588 4
5081-16 Color 5081-019 w/ RPQ	1280 x 1024	60*	39H8683
6091-19 Color	1280 x 1024	60*	39H8683
6091-23 Color	1280 x 1024	60*	39H8683
POWERdisplay 17 POWERdisplay 20	1024 x 768	74	39H8683
		76	39H8683
	1280 x 1024	60*	39H8683
		77	39H8683
P50	1024 x 768	74	Cable Included with Display
		75	Cable Included with Display
		85	Cable Included with Display
	1280x1024	60*	Cable Included with Display
P70	1024 x 768	70	96G2156
		74	96G2156
		75	96G2156
		85	96G2156
	1280 x 1024	60*	96G2156
		75	96G2156
		77	96G2156
P200	1024 x 768	70	96G2156
		74	96G2156
		75	96G2156
		85	96G2156
	1280 x 1024	60*	96G2156
		75	96G2156
		77	96G2156
		85 5	96G2156

Display Type	Screen Resolution (Non-Interlaced)	Refresh Freq (Hz)	Adapter Cable Part Number
P201	1024 x 768	70	96G1712
		74	96G1712
		75	96G1712
		85	96G1712
	1280 x 1024	60*	96G1712
		75	96G1712
		77	96G1712
		85	96G1712
9516-A03 (US/EMEA) 9516-A04 (AP)	1280 x 1024	60*	39H8682
Other VESA Resolutions/Refresh Rates	1024 x 768	60	
		70	
		75	
		85	
	1280 x 1024	60*	
		75	
		85	

Note:

* Default display mode. Monitors listed are selectable via the AIX utility (SMIT) except where noted.

¹ For 6091-16 Color/POWERdisplay 16 at 60 Hz, set the monitor display mode switch to out(1).

² For 6091-16 Color/POWERdisplay 16 at 77 Hz, set the monitor display mode switch to in(2).

³ For 6091-19i Color/POWERdisplay 19 at 60 Hz, set the monitor display mode switch to 2.

⁴ When installing cable P/N 09G3588, the black leaded BNC connector (labeled "V") *must* be connected to the "VD" sync out connector on the back of the display.

⁵ Only P200 Monitors with the N2 Chassis (M/T 6555, Model 77x) support 1280x1024 at 85Hz.

I/O Adapter Cabling

This section provides information on cabling for I/O adapters.

FC 6211 (High-Performance Disk Drive Subsystem Adapter)

The following figure illustrates the High-Performance Disk Drive Subsystem Adapter with attachment cable.

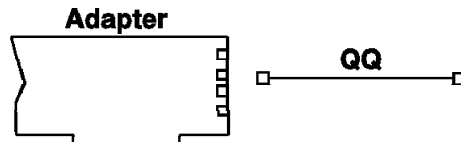

Cable Letter	Cable Name/Description	Part Number	Feature Code	Length	
				m	ft
QQ	Serial Link Cable	07G4859	N/A	3	10
		07G4860	N/A	10	33

High-Availability Configurations

All 7013 and 7015 systems can share a 9333 Model 500 or Model 010 respectively with another system unit. Such configurations may increase system availability and aid in recovery from certain types of hardware, software, and media failures. If one of the systems involved, or a High-Performance Disk Drive Subsystem Adapter fails, the other system can access the shared drives (with appropriate software support). Each 9333 Model 010 or Model 500 supports two independent adapter serial interfaces.

A typical high-availability configuration requires the following:

- Two POWERstations or POWERservers
- One or more High-Performance Disk Drive Subsystem Adapters per host system
- One SCSI High-Performance I/O Controller per system and at least one SCSI disk drive, which can be used to boot the system
- Two or more 9333 Model 010 Drawers or 9333 Model 500 Subsystems (this allows mirroring of data files across drawers or subsystems, preventing a single point of failure)
- Sufficient 10m (33 ft) Serial Link Cables to connect system units with drawers or subsystems.

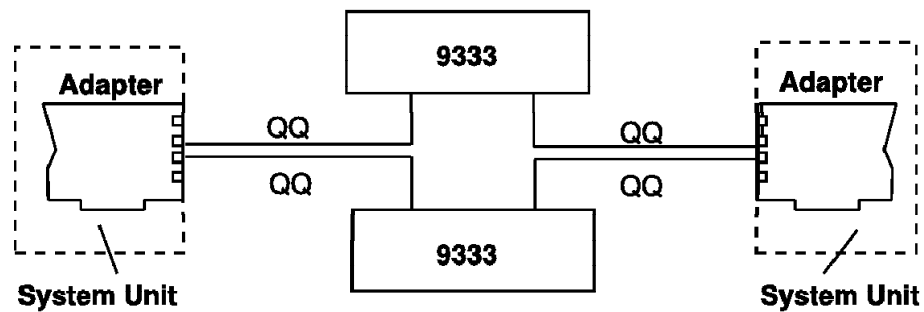

Cable Letter	Cable Name/Description	Part Number	Feature Code	Length m ft
QQ	Serial Link Cable	07G4859	N/A	3 10
		07G4860	N/A	10 33

FC 6212 (High-Performance Subsystem Adapter 40/80MB/Sec)

The following figure illustrates the High-Performance Subsystem Adapter 40/80MB/Sec with attachment cable.

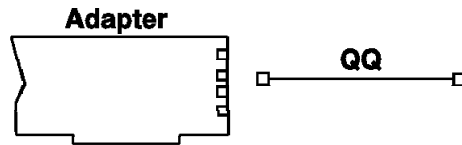

Cable Letter	Cable Name/Description	Part Number	Feature Code	Length	
				m	ft
QQ	Serial Link Cable	07G4859	N/A	3	1
		07G4860	N/A	10	33

High-Availability Configurations

All 7013 and 7015 systems can share a 9333 Model 501 or Model 011 respectively with another system unit. Such configurations may increase system availability and aid in recovery from certain types of hardware, software, and media failures. If one of the systems involved, or a High-Performance Disk Drive Subsystem Adapter fails, the other system can access the shared drives (with appropriate software support). Each 9333 Model 011 or Model 501 supports two independent adapter serial interfaces.

A typical high-availability configuration requires the following:

- Two system units
- One or more High-Performance Disk Drive Subsystem Adapters per host system
- One SCSI High-Performance I/O Controller per system and at least one SCSI disk drive, which can be used to boot the system
- Two or more 9333 Model 011 Drawers or 9333 Model 501 Subsystems (this allows mirroring of data files across drawers or subsystems, preventing a single point of failure)
- Sufficient 10-m (33-ft) Serial Link Cables to connect system units with drawers or subsystems.

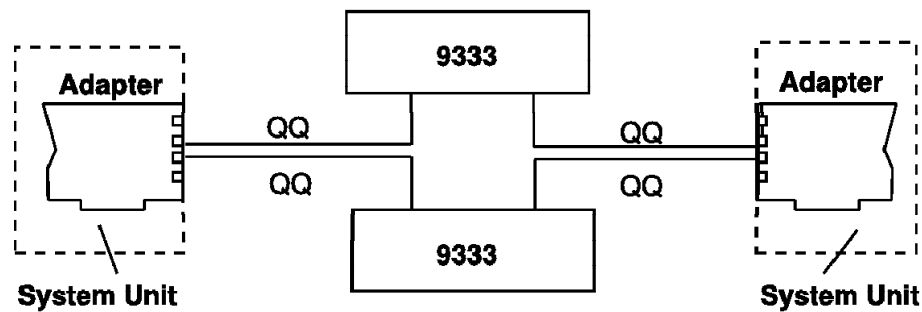

Cable Letter	Cable Name/Description	Part Number	Feature Code	Length m ft
QQ	Serial Link Cable	07G4859	N/A	3 10
		07G4860	N/A	10 33

The figure above shows two systems attached to a 9333 Subsystem Model 011 or 501. The Model 9333 Models 011 and 501 can attach to up to eight system units at the same time.

Cabling Considerations for 9333 High-Performance Disk Drive Subsystems

The following points should be considered when connecting the 9333 High-Performance Disk Drive Subsystem to the system:

- Up to four subsystems can be connected to a High-Performance Disk Drive Subsystem Adapter, providing up to sixteen disk drives per adapter. The subsystems cannot be serially connected, and there are no external terminators to be installed or removed.
- 9333 Model 010 Drawer subsystems can be installed in the same rack as the CPU drawer, or in a nearby expansion rack.
- There are no address switches in 9333 subsystems. The addresses are determined only by the way in which the subsystems are connected to the system.
- 9333 subsystems can be connected to two High-Performance Disk Drive Subsystem Adapters, either in the same or in different system units. If a subsystem is connected to two adapters in two different systems, ensure that the address of that subsystem on each of the systems is carefully recorded to avoid confusion between similarly addressed devices on the two systems. Information regarding the checking of disk drive addresses in 9333 subsystems can be found in 9333 documentation.

FC 6214, 6216, 6217, and 6219 (SSA Subsystems Attaching to SSA Adapters)

Use this section when connecting SSA subsystem units (such as the 7133 or 7131 model 405) to SSA Adapters (such as the Enhanced SSA 4-Port Adapter, the SSA 4-Port RAID Adapter, or the Micro Channel SSA Multi-Initiator/RAID EL Adapter).

This section provides the configuration rules for each SSA adapter, a general introduction to SSA cabling, and details of the SSA cables.

The installation and service manuals for each SSA subsystem unit have more information that relates to connecting that unit; those manuals contain cabling details for sample configurations that meet the simplest requirements. Marketing Representatives have information on more complex configurations for installations where performance or availability are particularly important.

SSA Loops, Links, and Data Paths

In the simplest SSA configuration, SSA devices are connected through two or more SSA links to an SSA adapter that is located in a using system. The devices, SSA links, and SSA adapter are configured in loops. Each loop provides a data path that starts at one connector of the SSA adapter and passes through a link (SSA cable) to the devices. The loop continues through the devices and returns through another link to a second connector on the SSA adapter.

The maximum permitted length for an external copper cable that connects two SSA nodes (disk drives or adapters) is 25 meters (82 feet).

Nodes that have the fibre-optic extender (feature code 5500 on MT 7133) feature can be connected by fiber optic cable over a maximum permitted length of 2.4 kilometers (7874 feet).

All devices that are attached to an SSA adapter card **1** are connected through SSA links **2**. Data and commands to a particular device pass through all other devices in the loop between the adapter and the target device.

Data can travel in either direction round a loop. The adapter can, therefore, access the devices **3** through two data paths. The using system cannot detect which data path is being used.

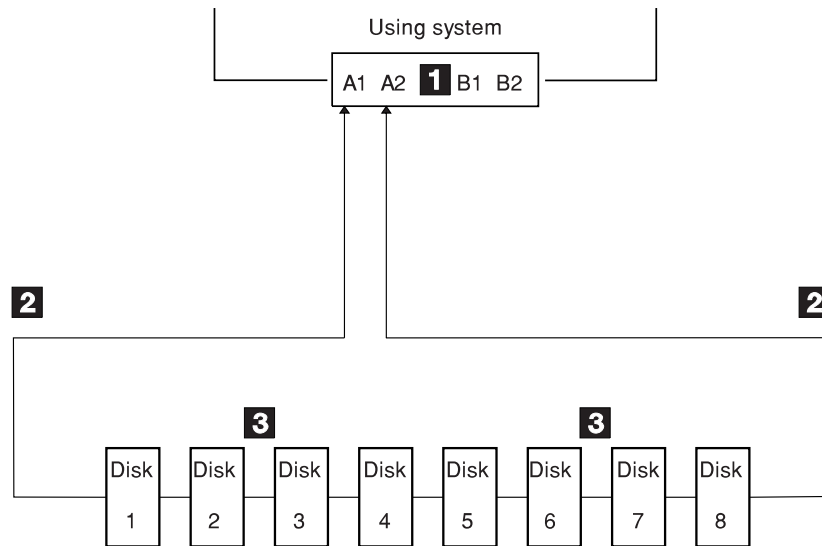

If a disk drive fails, or is turned off, the loop is broken, and one of the data paths to each disk drive is no longer available. The other disk drives continue to work through the remaining data path, but an error is reported to the system.

Rules for SSA Loops

For SSA loops that include the SSA 4-Port Adapter (FC 6214, type 4-D) or the Enhanced SSA 4-Port Adapter (FC 6216, type 4-G), the following rules apply:

- Each SSA loop must be connected to a valid pair of connectors on the SSA adapter (that is, either connectors A1 and A2, or connectors B1 and B2).
- Only one of the two pairs of connectors on an adapter card can be connected in a particular SSA loop.
- A maximum of 48 devices can be connected in a particular SSA loop.
- A maximum of two pairs of adapter connectors can be connected in a particular loop if one adapter is an SSA 4-Port Adapter (type 4-D).
- A maximum of eight pairs of adapter connectors can be connected in a particular SSA loop if all the adapters are Enhanced SSA 4-Port Adapters (type 4-G).
- A maximum of two SSA adapters, that are connected in a particular SSA loop, can be installed in a single host system unit.

For SSA loops that include the SSA 4-Port RAID Adapter (FC 6217, type 4-I), the following rules apply:

- Each SSA loop must be connected to a valid pair of connectors on the SSA adapter (that is, either connectors A1 and A2, or connectors B1 and B2).
- A maximum of 48 devices can be connected in a particular SSA loop.
- Only one pair of adapter connectors can be connected in a particular SSA loop.

For SSA loops that include the Micro Channel SSA Multi-Initiator/RAID EL Adapter (FC 6219, type 4-M), the following rules apply:

- Each SSA loop must be connected to a valid pair of connectors on the SSA adapter (that is, either connectors A1 and A2, or connectors B1 and B2).

- A maximum of 48 devices can be connected in a particular SSA loop.
- If the fast-write cache or RAID functions of the adapter are used, no other adapter can be connected in an SSA loop with this adapter.
- If the fast-write cache or RAID functions of the adapter are not used, a second Micro Channel SSA Multi-Initiator/RAID EL Adapter (or a PCI SSA Multi-Initiator/RAID EL Adapter) can be connected in the loop.

SSA Cables for 7133

The following SSA cables are available as features of the 7133:

Part Number	Feature Code	Length	
		m	ft
07H9163	5002 (See note)	0.18	0.6
31H7960	5006 (See note)	0.6	1.9
07H8985	5010	1.0	3.3
32H1465	5025	2.5	8.2
88G6404	5050	5.0	16.4
32H1466	5100	10	32.8
88G6406	5250	25	82.0

Note: For Models 010 and 500 only

If you order one or more 7133 Model 010 or 020 units as part of a new RS/6000 system, some cables are supplied with each 7133 unit. These cables might be connected to the unit, or the adapter, or both. Which cables are supplied depends on the number of disk drives that are installed in the 7133 unit:

Number of Disk Drives	Number of Cables	Part Number	Feature Code	Length	
				m	ft
1 through 4	2	88G6404	5050	5.0	16.4
5 through 8	2	88G6404	5050	5.0	16.4
	1	07H8985	5010	1.0	3.3
9 through 12	2	88G6404	5050	5.0	16.4
	1	07H8985	5010	1.0	3.3
	1 (Model 010 only)	07H9163	5002	0.18	0.6
13 through 16	2	88G6404	5050	5.0	16.4
	2	07H8985	5010	1.0	3.3
	1 (Model 010 only)	07H9163	5002	0.18	0.6

Some of these cables might have to be disconnected and discarded when the system is installed.

SSA Cables for 7131

This section provides information on cabling for 7131 model 405 to the SSA 4-Port Adapters.

Pages 3-65 and 3-66 show two configurations for SSA subsystems using 7131 units.

Attention: When you connect the SSA cables to a 7131 unit, always connect them as specified in the diagram; this enables operators and service representatives to identify the disk drives more easily.

MT 7131 Model 405

Important: All of the feature codes listed for the SSA Copper Cables (item **2**) in the following table are feature codes of machine type 7131.

Item	Description	Part Number	Feature Code	Length	
				m	ft
1	SSA 4-Port Adapter	31H3614	6214 feature of system unit	N/A	N/A
1	Enhanced SSA 4-Port Adapter	40H5707	6216 feature of system unit	N/A	N/A
1	SSA 4-Port RAID Adapter	89H5617	6217 feature of system unit	N/A	N/A
1	Micro Channel SSA Multi-Initiator/ RAID EL Adapter	84H9706	6219 feature of system unit	N/A	N/A
2	SSA Cable, 7131 to Adapter	07H8985	2895*	1.0	3.3
		32H1465	2896	2.5	8.2
		88G6404	2897	5.0	16.4
		32H1466	2898	10	32.8
		88G6406	2899	25	82.0

Base Configuration

A 7131 unit base configuration includes two disk drive carrier assemblies. These carrier assemblies are installed in the lower two slots of the 7131 unit. The other 3 disk drive positions contain dummy disk drive carrier assemblies.

In the simplest configuration, the SSA loop is completed by connecting the two SSA connectors on the 7131 unit to one of the two pairs of connectors on an SSA adapter card in the using system:

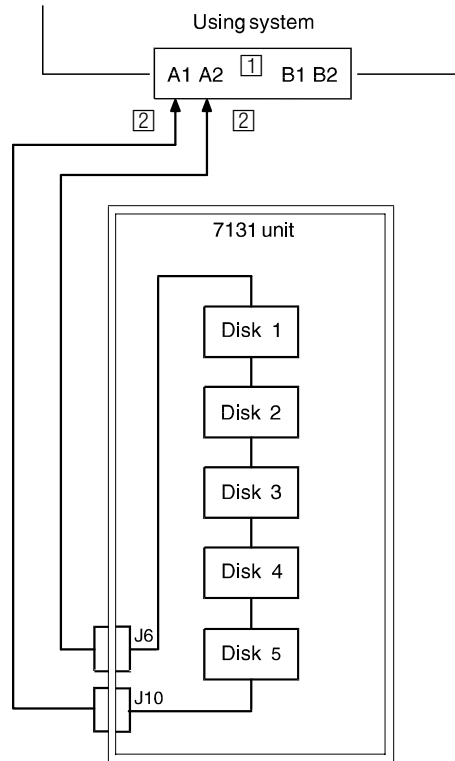

Note: The cables shown in the diagram above are described on page 3-64.

Loop Configuration using Four 7131 Units

All 20 disk drive carrier assemblies in the four full 7131 units are connected in a single loop.

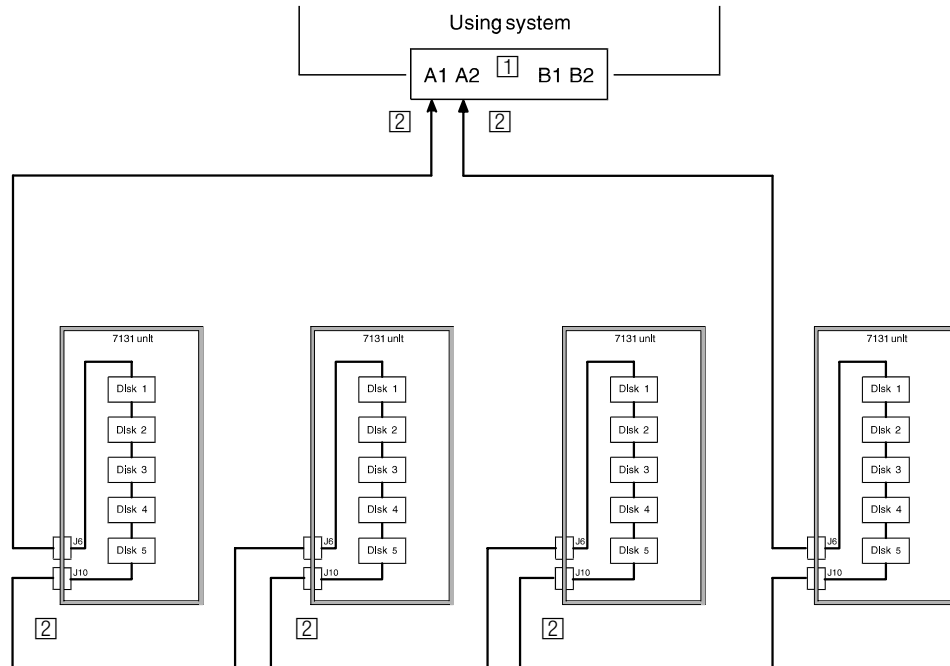

For a higher-availability configuration, a second SSA adapter can be included in the loops.

Note: The cables shown in the diagram above are described on page 3-64.

FC 2401 (M-Video Capture Adapter)

The following figure illustrates the M-Video Capture Adapter with an attachment cable.

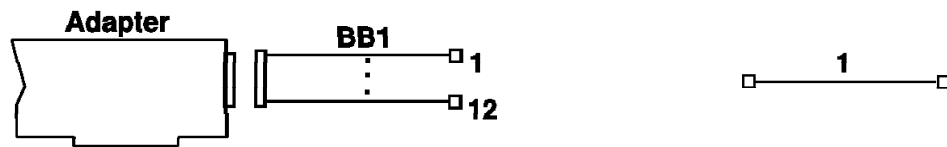

Cable Letter	Cable Name/Description	Part Number	Feature Code	Length m ft
1	Customer-supplied cable	N/A	N/A	N/A
BB1	Supplied cables	92F3714	N/A	N/A

FC 6300 (9291/9295 Digital Trunk Adapter)

The following figure illustrates the 9291/9295 Digital Trunk Adapter with an attachment cable.

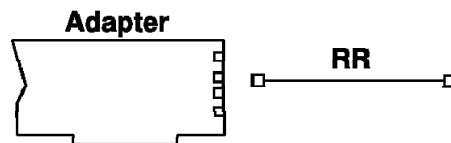

Cable Letter	Cable Name/Description	Part Number	Feature Code	Length m ft
RR	Cable to 9291/9295 assembly, provided with VPACK	34F0873	N/A	2 6.6

FC 6301 (M-Audio Capture and Playback Adapter)

The following figure illustrates the M-Audio Capture and Playback Adapter with an attachment cable.

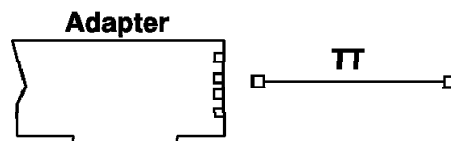

Cable Letter	Cable Name/Description	Part Number	Feature Code	Length m ft
TT	Customer-supplied cable	N/A	N/A	

FC 6302 (Ultimedia Audio Adapter)

The following figure illustrates the Ultimedia Audio Adapter.

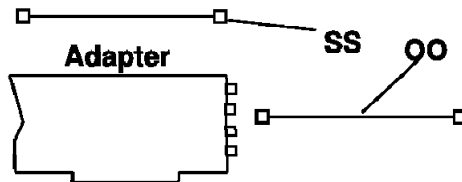

Cable Letter	Cable Name/Description	Part Number	Feature Code	Length m ft
OO	Customer-supplied cables: Line In cable, Microphone In cable Line out cable, and Headphone out cable	N/A	N/A	
SS	Internal CD-ROM cable (supplied with adapter)	NA	NA	NA

FC 6304 (Ultimedia Video I/O Adapter)

The following figure illustrates the Ultimedia Video I/O Adapter with an attachment cable.

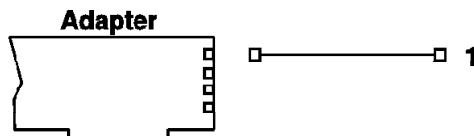

Cable Letter	Cable Name/Description	Part Number	Feature Code	Length m ft
1	Customer-supplied cable for connection to: S-VHS mini din jack for video in C-VBS RCA type jack for video in S-VHS mini din jack for video out C-VBS RCA type jack for video out	N/A	N/A	N/A

Standard I/O Ports

There are many new Machine Types and Models of Systems. These new systems have a variety of standard I/O interfaces. Most of the new systems have interfaces as shown in the figure below. Some of the new systems have one or more of the following interfaces standard Ethernet, Token Ring and SCSI. Check the manuals that came with your system for the standard I/O interfaces on your system unit. See the appropriate cabling sections for cabling these interfaces. See “Attaching User Input Devices” on page 3-72.

The following figure illustrates the standard I/O ports (built into the planar board of many of the system units) with attachment cables. The 7015 system unit supports serial port 1 (S1), serial port 2 (S2), and parallel port (P) only. To make the necessary connections to this planar, your setup person needs to know how each port is used. The Standard I/O ports for Models G30, J30, and R30 are shown in topic 3-70.

Standard I/O

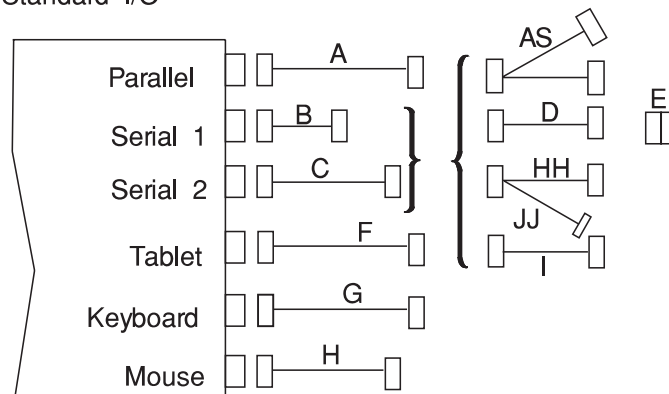

Cable Letter	Cable Name/Description	Part Number	Feature Code	Length	
				m	ft
A	PC Parallel Printer Cable	1525612 09F5544	3100	3	10 5 16.4
B	Serial port jumper cable, two provided with each system models 320, 32H, 520, 530, 540, and 550	00G0943	N/A	0.09	0.33
C	Serial port jumper cable for 7015 Models 930 and 950, two provided with each system unit	59F4533	N/A	3	10
D	Async Cable-EIA-232/V.24, if customer-supplied, must meet EIA-232D requirements	6323741	2936	3	10
E	Printer/Terminal Interposer EIA-232	58F2861	2937	N/A	
F	Tablet cable, supplied with tablet	6247480	2811	2.1	7
G	Keyboard cable, supplied with keyboard	N/A	N/A	3	10
H	Mouse cable, supplied with mouse	N/A	N/A	2.75	9
I	Printer/Terminal Cable EIA-232 if customer-supplied, must meet EIA-232D requirements	12H1204	2934	3	10

Cable Letter	Cable Name/Description	Part Number	Feature Code	Length m ft
AR	Serial port jumper cable that converts from a 9-pin D-shell connector to a 25-pin D-shell (supplied with the system unit).	6133917	N/A	.25 0.83
AS	Serial port fanout cable feature that makes the second serial port available from a single serial port connector on the back of some Models	31F4590	3107	0.17 0.57
HH	6094 Attachment Cable, attaches to both device and power cable (JJ)	39F8228	4060	1.8 6
JJ	Power cable for 6094, attaches to display	39F8302	4061	1.8 6

The following figure illustrates the standard I/O ports with attachment cables for Models G30, J30, and R30. The cables are described in the table above.

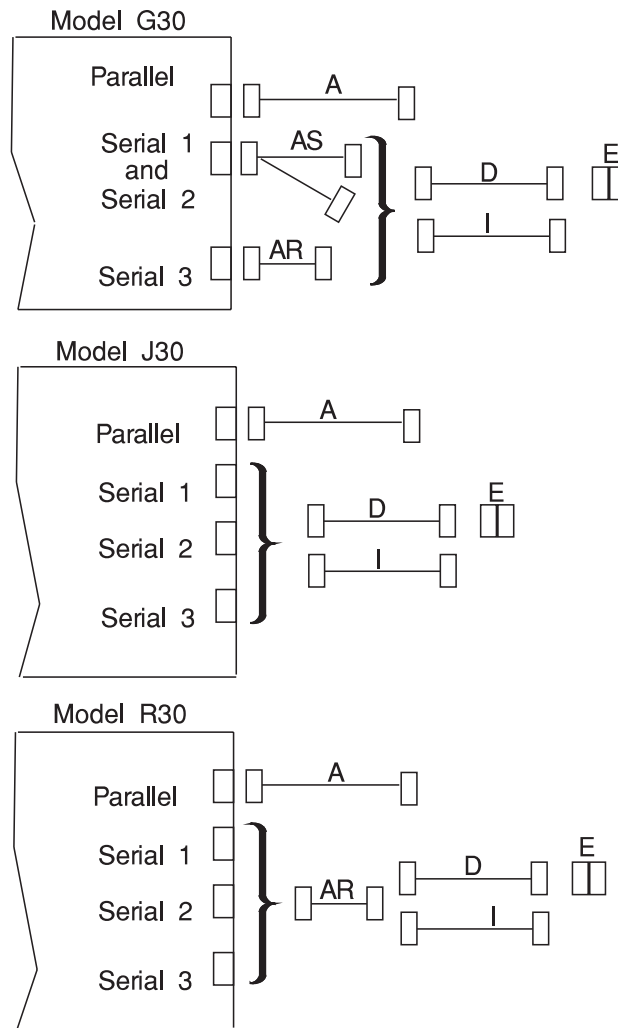

Re-IPL Cabling

This section provides information on cabling for serial Re-IPL.

FC 3122 and 3123 (Serial to Re-IPL Port Re-IPL Cables)

The following figure illustrates how to install a serial Re-IPL cable.

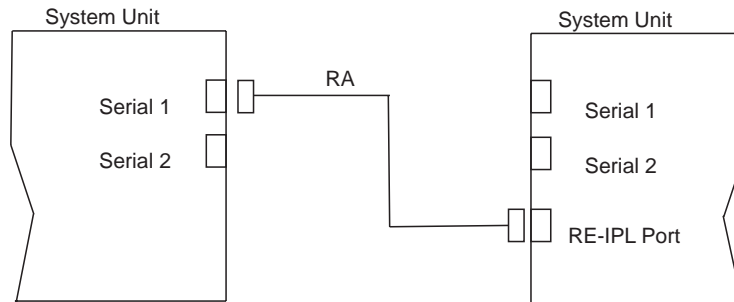

Cable Letter	Cable Name/Description	Part Number	Feature Code	Length m ft
RA	Serial to Re-IPL Port Can be customer-supplied	65G6887	3122	3.7 12
RA	Serial to Re-IPL Port Can be customer-supplied	65G6979	3123	8 39.4

FC 3124 and 3125 (Serial to Serial Port Re-IPL Cables)

The following figure illustrates how to install a serial Re-IPL cable.

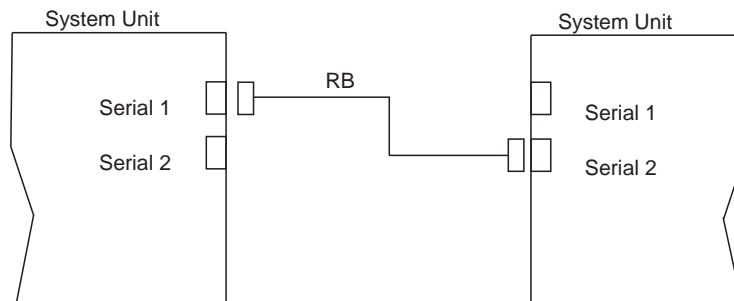

Cable Letter	Cable Name/Description	Part Number	Feature Code	Length m ft
RB	Serial to Serial Port Can be customer-supplied	88G4853	3124	3.7 12
RB	Serial to Serial Port Can be customer-supplied	88G4854	3125	8 39.4

Attaching User Input Devices

The following topics show how to attach user input devices to system units. This is shown for example only; some system units do not support user input devices.

Attaching to the Standard I/O Interfaces

When Ethernet, Token-Ring, SCSI or SCSI-2 come as standard interfaces, their attachment is shown in the specified section.

Keyboard

The following drawing shows the keyboard attached to the standard I/O port K. The keyboard cable is supplied with the keyboard.

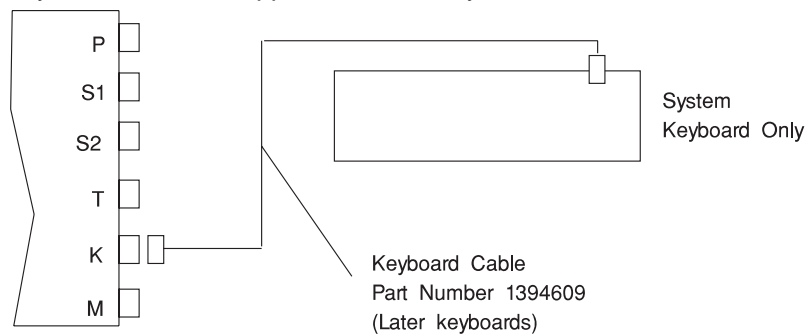

Speaker and Keyboard

Some systems were shipped that did not have a speaker in the keyboard or the system unit. The following drawing shows the keyboard attached to a speaker box with a 3 ft. cable which attaches to the standard I/O port K. The speaker box has a keyboard connector to pass the keyboard signals through to the keyboard. The keyboard cable is supplied with the keyboard.

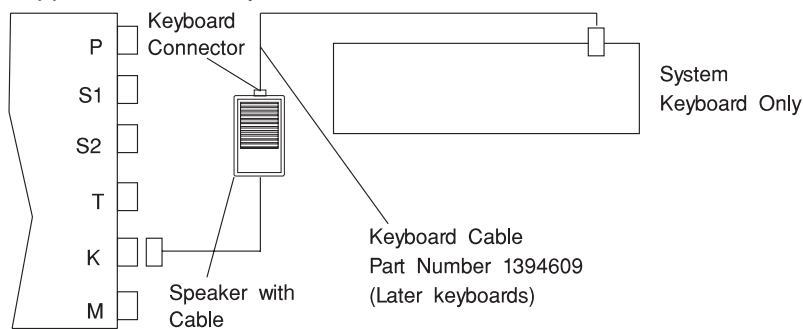

Mouse

The following drawing shows the mouse attached to the standard I/O port M.

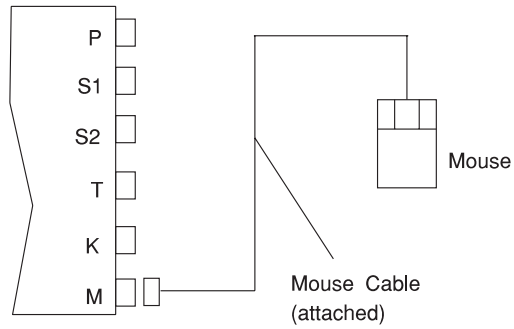

5083 Tablet

The following drawing shows the tablet attached to the standard I/O port T. The cursor or stylus attaches to the tablet.

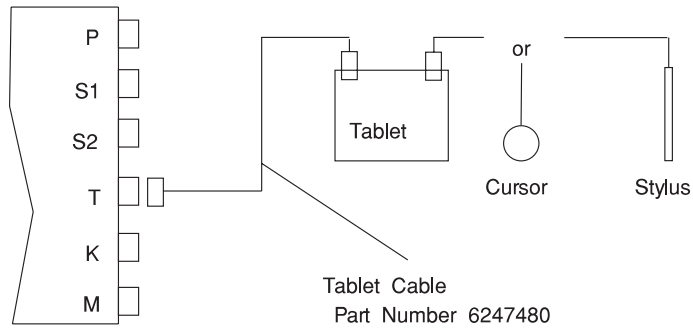





Attaching the Graphic Displays

There are several graphic displays and display adapters used with system units. There are three ways to attach graphic displays to the system units:

- Attach a monochrome display using a 15-position D-shell connector.
- Attach a color graphics display using an RGB video cable.
- Attach the 7235 using a 68-position D-shell connector. The color graphics display then attaches to the 7235.

The following examples show the cabling arrangements.

5081 or 6091 Display Attached to a Color Graphics Adapter

The following drawing shows a 5081 or 6091 display attached directly to a color graphics display adapter in the system unit.

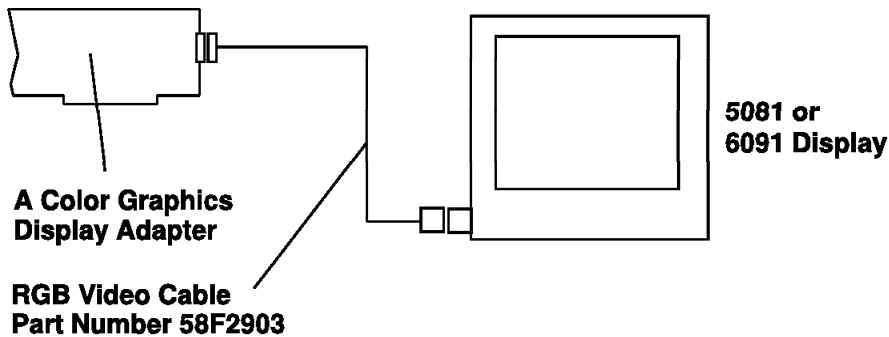

5081 or 6091 Display Attached to a 7235

The following drawing shows a 7235 attached directly to a graphics subsystem adapter in the system unit.

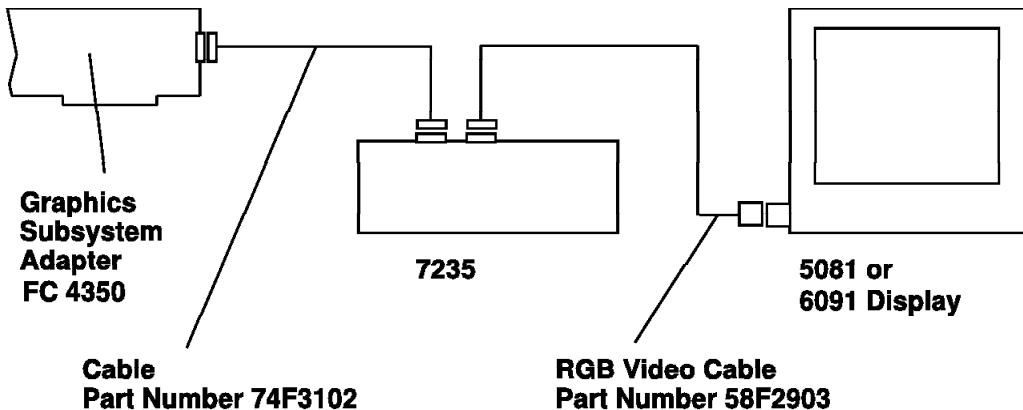

8508 Display

The following drawing shows an 8508 display attached directly to a grayscale graphics display adapter in the system unit. Attach the toroids (there may be only one) to the display signal cable near the adapter.

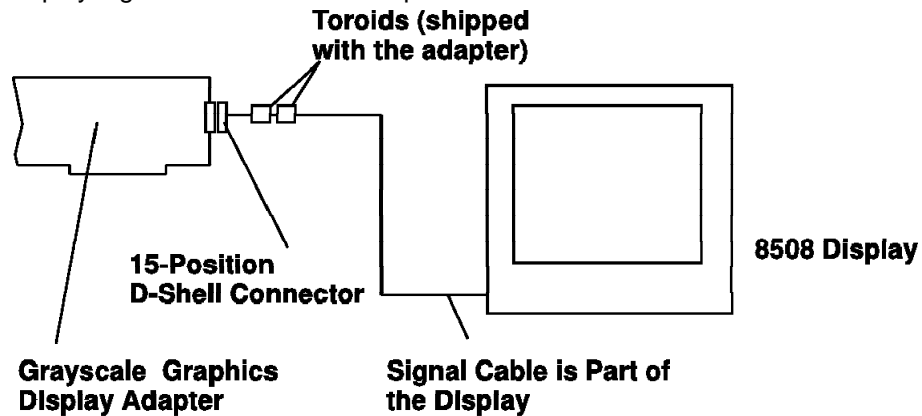

Attaching the External Diskette Drive

Some of the early early model system units had 5.25-inch diskette drives for compatibility with previous systems.

4869 5.25-Inch

The following drawing shows a 4869 attached to the optional external diskette drive connector on a system unit.

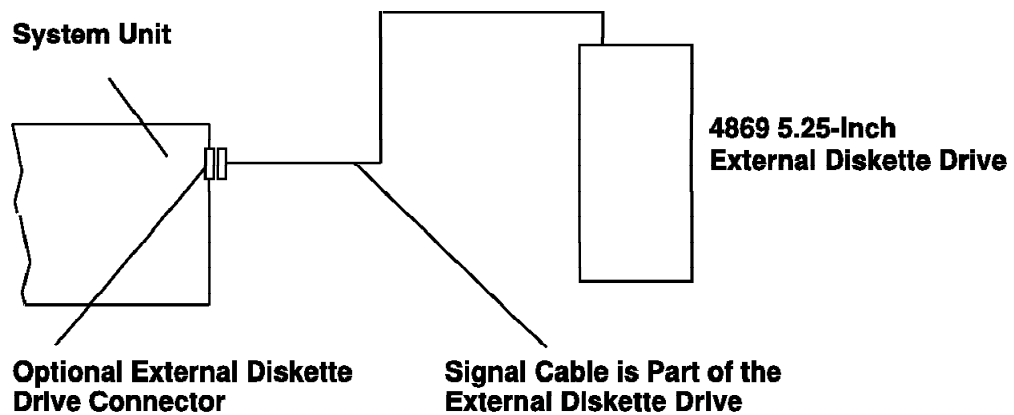

Attaching to the M-Video Capture Adapter (NTSC Version)

Connecting Input Devices

All input devices are connected via the Primary I/O cable.

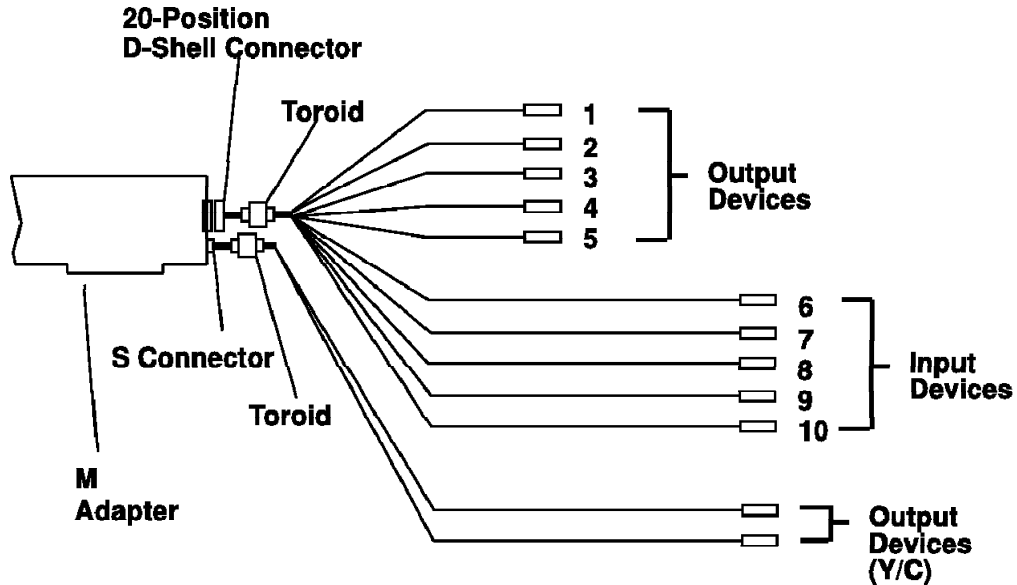

Note: The Primary I/O cable is not intended to attach directly to input/output devices; RCA plugs are required.

Input Device	Connections
NTSC Composite Video	Cable -10
RGB with Separate Composite Analog Sync Note: The composite analog sync may come from the composite video output of a camera. If this camera composite video output is used for the sync input, do not use the camera as a composite video source as well.	Red to Cable -9 Green to Cable -8 Blue to Cable -7 Composite Analog Sync to Cable -6
RGB with Sync on Green	Red to Cable -9 Green to Cable -8 Blue to Cable -7
Y/C Video Note: RGB and Y/C inputs cannot be used simultaneously. Use shielded cables.	Chroma (C) to Cable -9 Luma (Y) to Cable -8

Connecting Output Devices

The M-Video Capture Adapter simultaneously drives NTSC, RGB, and Y/C output monitors.

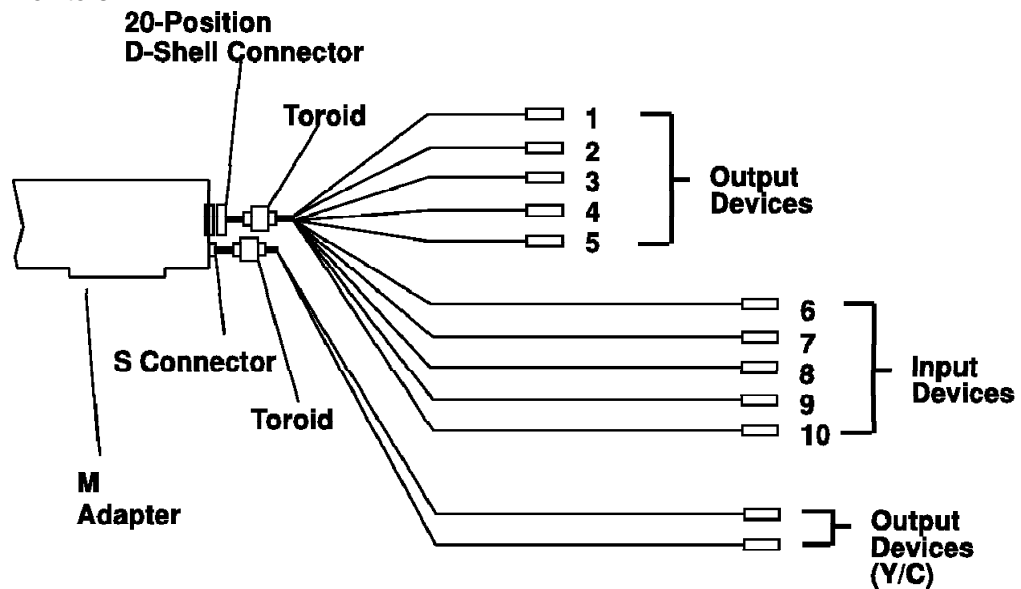

Note: The Primary I/O cable is not intended to attach directly to input/output devices; RCA plugs are required.

Output Device	Connections
NTSC Monitor	Cable -5
RGB with Sync on Green	Red to Cable -4 Green to Cable -3 Blue to Cable -2
Note: If the Sync on Green output is used, the NTSC Y/C outputs are <i>not</i> usable.	
RGB with Separate Sync	Red to Cable -4 Green to Cable -3 Blue to Cable -2 Sync to Cable -1
Y/C Monitor	Monitor to S-Connector Cable

Attention: The Red, Green and Blue video outputs must be terminated in 75 ohms or all outputs will be overdriven. 75-ohm termination is normally built into the monitors, but ensure that the 75-ohm switch is properly set. If you are not using a 75-ohm terminated RGB video display, use the 75-ohm terminator plugs supplied with the M-Video Capture Adapter.

Attaching to the M-Video Capture Adapter (PAL Version)

Connecting Input Devices

All input devices are connected via the Primary I/O cable.

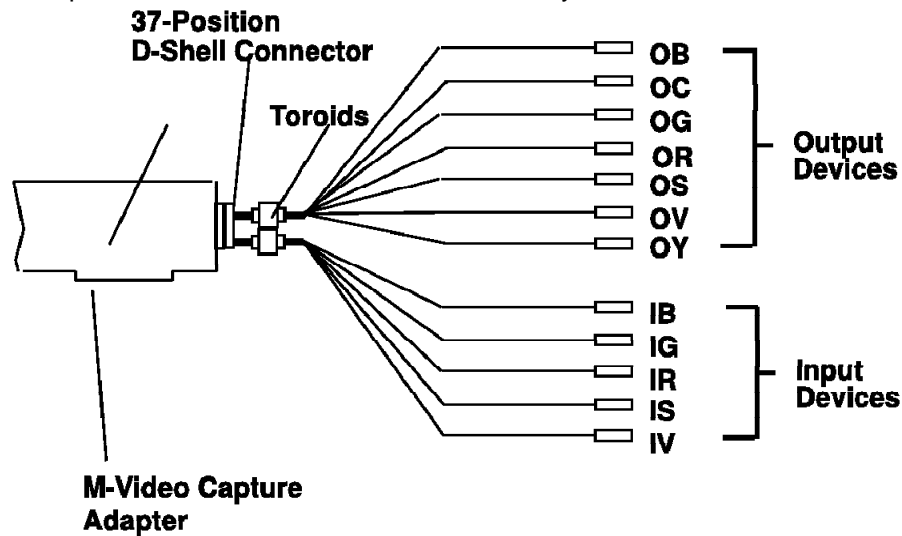

Note: The Primary I/O cable is not intended to attach directly to input/output devices; RCA plugs are required.

Input Device	Connections
Pal Composite Video	Cable IV
RGB with Separate Composite Analog Sync Note: The composite analog sync may come from the composite video output of a camera. If this camera composite video output is used for the sync input, do not use the camera as a composite video source as well.	Red to Cable IR Blue to Cable IB Green to Cable IG Composite Analog Sync to Cable IS
RGB with Sync on Green	Red to Cable IR Green to Cable IG Blue to Cable IB
Y/C Video	Chroma (C) to Cable IR Luma (Y) to Cable IG
Notes: 1. RGB and Y/C inputs cannot be used simultaneously. 2. Use shielded cables.	

Connecting Output Devices

The M-Video Capture Adapter simultaneously drives PAL, RGB, and Y/C output monitors.

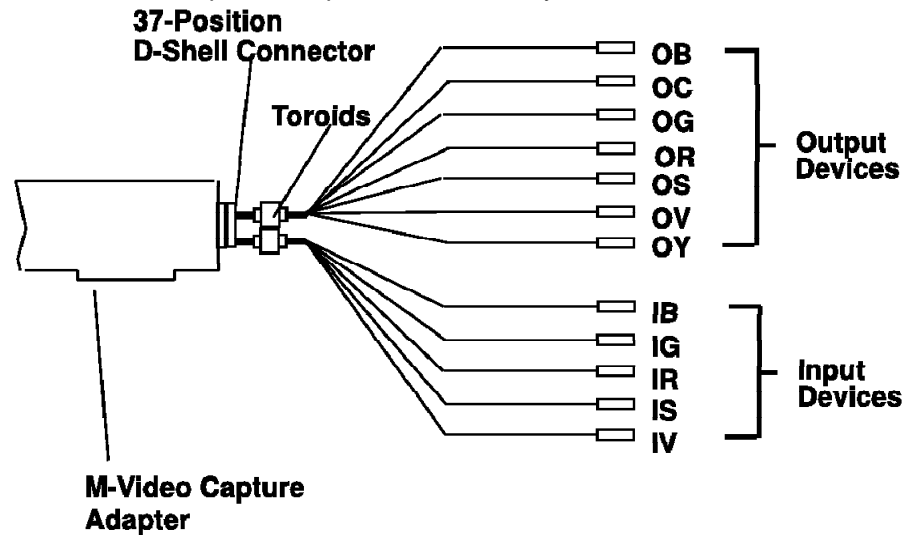

Note: The Primary I/O cable is not intended to attach directly to input/output devices; RCA plugs are required.

Output Device	Connections
PAL Monitor	Cable OV
RGB with Sync on Green Note: If the Sync on Green output is used, the PAL and Y/C outputs will <i>not</i> be useable.	Red to Cable OR Green to Cable OG Blue to Cable OB
RGB with Separate Sync	Red to Cable OR Green to Cable OG Blue to Cable OB Sync to Cable OS
Y/C Monitor	Chroma (C) to Cable OC Luma (Y) to Cable OY

Attention: The Red, Green, and Blue video outputs must be terminated in 75 ohms or all outputs will be overdriven. 75-ohm termination is normally built into the monitors, but ensure that the 75-ohm switch is properly set. If you are not using a 75-ohm terminated RGB video display, use the 75-ohm terminator plugs supplied with the M-Video Capture Adapter.

Chapter 4. SCSI Cabling

Description of the SCSI Cable Information

The following sections describe the cabling, termination, and addressing for all SCSI controllers. There are many descriptions describing how to cable various controllers to the SCSI devices.

Note: The end brackets of non-OEM SCSI-2 differential controllers carry the label, "Differential."

OEM SCSI-1 or SCSI-2 single-ended and SCSI-2 differential controllers may carry one of the following ANSI icons:

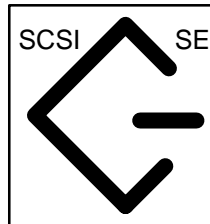

Single-Ended

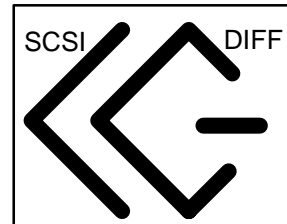

Differential

How to Find the 5% You Need to Know

The following SCSI cable section contains lots of information on all of the SCSI Controllers, cables, terminators and SCSI rules. If all you want to do is attach one SCSI device to a SCSI controller, you do not need all of this information and you can follow the quick procedure below. If you are attaching more than one device to a controller, you need to read the entire general section and all of the detail section for the SCSI controller so you understand all of the controller rules.

QUICK Procedure to attach one device.

- Go to table “External SCSI Devices” on page 4-4 and look up the device you want to attach. Make a note of its characteristics.
- Go to table “Cabling SCSI Devices” on page 4-3 and in the first column look up the controller to which you want to attach the device. (**Note:** You cannot attach single-ended (SE) devices to differential controllers or visa-versa). Note the page number from the first column.
- Go to the page for the selected controller and continue forward until you come to the “Controller-to-First Device Cable Table.” Look up the cable you need. Both the feature code and part number are provided. The machine type (MT) column tells you if the cable is ordered with the system or with the device.

Example: You want to attach a 7204-010 external 1GB disk drive.

- From the table “External SCSI Devices” on page 4-4, you record that the 7204-010 is an 8-bit, single-ended dual connector device.
- You decide to connect this device to the SCSI-2 Fast /Wide controller. From “Cabling SCSI Devices” on page 4-3 you see that the cabling information for this controller starts on “Cabling the SCSI-2 Single-Ended Fast/Wide Controller FC 2414, 2415, and 9216” on page 4-40page only.
- You go to “Cabling the SCSI-2 Single-Ended Fast/Wide Controller FC 2414, 2415, and 9216” on page 4-40 and continue to the “Controller-to-First Device Cables” on page 4-41. From this table you choose feature code 2437 which is the cable to attach an 8-bit device which has 2 connectors.
- From the MT column, you know to order that feature code against the host system.

Note: The terms SCSI IDs and SCSI addresses are used interchangeably in the publication.

Cabling SCSI Devices

The table below shows where in this section to look for information on cabling specific SCSI configurations:

Note: To understand the cabling for the SCSI controllers read “General SCSI Considerations” on page 4-5, and then refer to the sections described in the table for information on specific SCSI cabling configurations.

Reference and Page	ID	Standard on Model	Type	Description	Label
“Cabling the SCSI I/O Controller FC 2828, 2829, and 2835” on page 4-8	SCSI-1	7013-520 thru 560 7015-930/950 7016-all models	Single-ended	Adapter	4-1
“Cabling the SCSI-1 Integrated Controller for Machine Types 7012, 7013, and 7015” on page 4-18	SCSI-1	7012-340 thru 375 7013-570 thru 590 7015-970 thru 990	Single-ended	Integrated	N/A
“Cabling the SCSI-2 Fast/Wide Integrated Controller for Machine Type 7012 Models 380/390/39H and 7030 Models 3AT/3BT/3CT” on page 4-16	SCSI-2	7012-380/390/39H 7030-3AT/3BT/3CT	Single-ended/ Single-ended	Integrated	N/A
“Cabling the SCSI Integrated Controller for Machine Types 7006, 7008, 7009, and 7011” on page 4-21	SCSI-1	7008 7011-220/230	Single-ended	Integrated	N/A
	SCSI-2	7006 7009 7011-250	Single-ended	Integrated	N/A
“Cabling the SCSI-2 Single-Ended Controller FC 2831 and 2410” on page 4-24	SCSI-2	7013-580/58H/590 7015-970/980	Single-ended	Adapter	4-4
“Cabling the SCSI-2 Differential I/O Controller FC 2420” on page 4-28	SCSI-2	N/A	Differential	Adapter	4-2
“Cabling the SCSI-2 Single-Ended Fast/Wide Controller FC 2414, 2415, and 9216” on page 4-40	SCSI-2	7013-59H 7012-G30 7015-R30	Single-ended/ Single-ended	Adapter	4-7
“Cabling the SCSI-2 Differential Fast/Wide Controller FC 2413, 2416, and 9217” on page 4-49	SCSI-2	7013-J30	Single-ended/ Differential	Adapter	4-6
Cabling for the Enhanced SCSI-2 Differential Fast/Wide Controller FC 2412, 9212, 2418 and 2419 uses the same cables as the “Cabling the SCSI-2 Differential Fast/Wide Controller FC 2413, 2416, and 9217” on page 4-49	SCSI-2	7013-J30/J40 7015-R40	Single-ended/ Differential	Adapter	4-C

External SCSI Devices

The table below shows some characteristics of some External SCSI Devices:

Machine Type / Model	Bus Width	SE or Diff	Connectors
7203 - 001	8 Bit	Single-ended	Single
7204 - 001	8 Bit	Single-ended	Single
7204 - 010	8 Bit	Single-ended	Dual
7204 - 112	16 Bit	Single-ended	Dual
7204 - 113	16 Bit	Single Ended	Dual
7204 - 114	16 Bit	Single Ended	Dual
7204 - 139	16 Bit	Single Ended	Dual
7204 - 215	8 Bit	Differential	Dual
7204 - 315	16 Bit	Differential	Dual
7204 - 317	16 Bit	Differential	Dual
7204 - 320	8 Bit	Single-ended	Single
7204 - 325	16 Bit	Differential	Dual
7204 - 339	16 Bit	Differential	Dual
7205 - 311	16 Bit	Differential	Dual
7206 - 001	8 Bit	Single-ended	Dual
7206 - 005	8 Bit	Single-ended	Dual
7207 - 001	8 Bit	Single-ended	Single
7207 - 011	8 Bit	Single-ended	Single
7207 - 012	8 Bit	Single-ended	Single
7207 - 315	16 Bit	Differential	Dual
7208 - 001	8 Bit	Single-ended	Single
7208 - 011	8 Bit	Single-ended	Single
7208 - 341	16 Bit	Differential	Dual
7209 - 001	8 Bit	Single-ended	Single
7209 - 002	8 Bit	Single-ended	Dual
7209 - 003	8 Bit	Single-ended	Dual
7210 - 001	8 Bit	Single-ended	Single
7210 - 005	8 Bit	Single-ended	Dual
7210 - 010	8 Bit	Single-ended	Dual
7210 - 015	8 Bit	Single-ended	Dual
7331 - 205	16 Bit	Differential	Quad
7331 - 305	16 Bit	Differential	Quad
7332 - 005	8 Bit	Single-ended	Dual
7131 - 105	16 Bit	Single-ended	Single
7131 - 105	16 Bit	Differential	Dual
7336 - 205	16 Bit	Differential	Quad

General SCSI Considerations

SCSI Terminators

- There must be exactly two terminators on the SCSI bus, and they must be located at each extreme end of the bus.
- If the configuration consists of a controller with external devices only (not high-availability), for all controllers except the SCSI-2 Fast/Wide Controller, connect the internal card edge terminator on the top edge connector of the SCSI-1 or SCSI-2 single-ended controller. Connect the SCSI device terminator (D-shell connector) to the last device on the bus.
- If the configuration consists of internal devices only, for all controllers except the SCSI-2 Fast/Wide Controller, connect the external terminator to the external connector of the SCSI controller. The internal cable contains a built-in terminator on the other end of the cable.
- If the configuration uses both internal and external devices, connect a terminator on the last external device on the bus, and use the internal cable with the built-in terminator.
- Some devices may be shipped with terminators attached. Remove these terminators.
- Some terminators are referred to as FPT-3 or FPT-18. The FPT stands for Forced Perfect Termination. Some cables integrate these terminators.

SCSI Bus Length General Guidelines

SCSI bus length is defined as the distance between terminators at either end of an SCSI bus.

- For configurations using both internal and external cabling, length restrictions refer to the length from the end of the internal cable (terminator) to the terminator on the last device on the external bus.
- Devices such as the 9334 - 010 or 9334 - 500 require a dedicated external SCSI-1 or SCSI-2 controller.
- Devices which have two SCSI connectors have internal cabling which must be included when calculating total cable length. When connecting these devices, connect one cable into one connector and the other cable (or terminator, if this is the last device on the bus) to the second connector. Do not "piggy back" the second cable/terminator onto the first as you would on a device with only one connector. See illustration below.

Single-Ended External Narrow Bus

This "piggy back" connector is not to be used if it is attached to a two connector device.

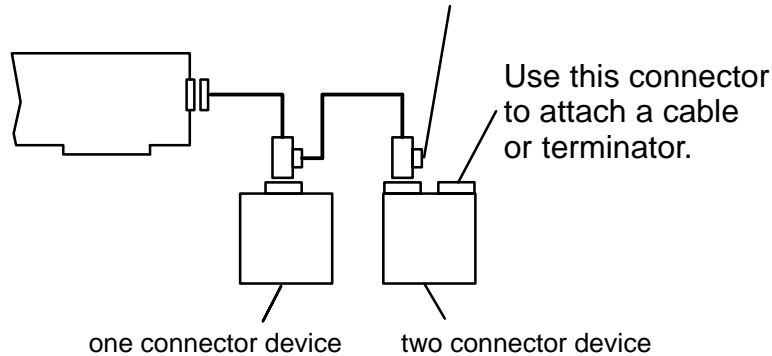

SCSI Device Addresses or IDs

The SCSI-1 and SCSI-2 single-ended controllers support a maximum of eight SCSI addresses.

- For any single-controller configuration, a maximum of seven additional devices are permitted, providing that the supported configuration specific bus lengths are not exceeded. Other restrictions such as bus length may further limit the number of allowable devices.
- For two-controller configurations (high-availability), up to six devices are permitted, providing that the supported configuration specific bus lengths are not exceeded. Other restrictions such as bus length may further limit the number of allowable devices.
- The SCSI bus address determines priority on the bus. Address priority from the highest to the lowest is as follows:
 - 7, ..0, 15,...8 (address 15 to 8 are only used on SCSI-2 wide buses). Address 7, the highest priority, must always be assigned to the controller. In general, assign the fastest devices the lowest priority. Disk drives should be assigned IDs in the range of 0 to 3; CD-ROMS in the range of 3 to 4, and tapes in the range of 4 to 6 (addresses 15 to 8 can also be used on SCSI-2 wide buses as additional lower-priority addresses)
- The default ID of the SCSI controller in a single controller configuration is 7. All devices on that bus must have a unique ID from 0 to 6 (8 to 15 are also valid if SCSI-wide); two different devices may not have the same SCSI ID. In the high-availability configurations, the second controller must have its address changed to avoid conflicts.

Note: The SCSI address switch for each device must be set while power to the system unit is off. The operating system determines the system configuration during IPL. If an SCSI address is changed after the operating system is loaded, the operating system must be stopped and loaded again to have the correct configuration. Standalone diagnostics always default to a SCSI ID of 7 when testing SCSI controllers and devices. Choosing SCSI IDs other than 7 for both controllers prevents any problems when using standalone diagnostics on systems in HA clusters or in multi-initiator configurations. Please check the SCSI documentation

for your specific SCSI subsystem to insure that there are no ID conflicts if the adapters are addressed at ID (s) other than 6 and 7.

To determine what SCSI addresses are available you must know what SCSI addresses are already in use. The following are several ways to do this:

- If the system is operational and AIX is loaded and configured, use the **lsdev -C -s scsi** (where the l in lsdev is a lowercase L) command to list all of the devices in the Customized Devices Object Class. The list shows name, status, location (the software location code), and the description.
- Use customer planning information supplied by the customer.
- Use the "About Your Machine" listing that was shipped with your system unit to determine the internal device addresses.
- Physically check each device address. Refer to Chapter 2 of this book to identify the SCSI address jumpers or switches.

Overload Protection and Terminator Power (Term Power)

The SCSI controllers provide term power for the SCSI bus; connect devices to the bus so they do not provide term power. The controller uses either a fuse that must be replaced after failure, or a positive temperature coefficient (PTC) resistor that resets within five minutes after the overload cause is removed. SCSI-2 controllers all use a PTC resistor.

- Do not connect or disconnect any SCSI device while power is on. Such "hot plugging" is forbidden because this practice may blow the controller fuse, trip the PTC resistor, corrupt data or permanently damage SCSI controller chips in controllers or devices.
- The fuse or PTC on an SCSI controller protects the external and internal SCSI bus. The fuse may be blown or the PTC tripped by a defective cable, terminator, or device attached to the controller, but not by a defective controller.

Controller Access Time

- Consider the following to keep controller access time within reasonable limits:
 - Have the disk being backed up and the backup device on separate controllers
 - Attach four or fewer disk drives to the same SCSI-1 controller and six or fewer disk drives to a SCSI-2 controller.
 - If possible have the high-usage disk drives (such as operating system drives) on the same controller with low-usage devices to improve access time.

Cabling the SCSI I/O Controller FC 2828, 2829, and 2835

To understand the cabling for this controller, read “General SCSI Considerations” on page 4-5, then read the following for specific information.

As Required Engineering Change (EC)

For all machines shipped prior to 16 May 1991 (and for some machines shipped between 17 May and 14 June 1991), any SCSI-1 High Performance Controller that has an internally installed SCSI device connected to the card edge connector can only have two externally attached devices. If the customer having this configuration wishes to use more than two external devices, an “As Required Engineering Change (EC)” which provides a new internal cable is available at no charge upon request by service personnel.

This EC is not required if only external devices are attached.

Grey-colored internal terminators crimped on the internal SCSI ribbon cable indicate that the EC has been installed; pre-EC terminators are blue or black.

SCSI-1 Single-Ended Cable Lengths Using this Controller

SCSI-1 single-ended cabling should be accomplished in accordance with the following criteria and machine type specifications.

Note: SCSI cable length maximums must be carefully observed to avoid transmission line mismatch problems.

- The maximum length of a chain of SCSI devices and cables is 6 m (19.7 feet). This maximum length includes the internal cabling of a device that has two connectors.
- For systems with both internal and external cables, the 6 m (19.7 feet) maximum is defined as the distance from the internal terminator to the external terminator.

Cable and Terminator Tables for SCSI-1 I/O Controller

The following tables and examples aid in properly cabling a SCSI bus.

System Internal Cable Lengths

Machine Type	Feature Code	Description	Cable Length (meters)
7012/320/32H	2828	Disk drive SCSI Option	0.5
7013 thru 560	*	First card, with internal devices	3.67
7013	2829	Second card, with internal devices	1.56
7015/930/950	*	Length inside CPU drawer	1.2
7016	*		2.37
Note: * These cables ship with the base machine and cannot be ordered separately			

Note: All differential cables are terminated at the end of the cable farthest from the SCSI controller.

Controller-to-First Device Cables

MT	F/C	Cable Description	Part Number	Cable Length (meters)
Host System	2832	Controller-to-first-device (where the first device has one connector)	70F9733 31F4221	1.57
7204-010 7206-005 7209-002 7210-005	2837/ 9123	Controller-to-first-device (where the first device has two connectors.)	33F4606	1.5
9334	2919 2917	Controller-to-9334/500	07G5143 07G5127	2.38 1.57
Host System 9334	2832 9205 9203	Controller-to-9334/010 or media drawer (7015 system)	71F1072 31F4223 71F1073 31F4224	2.38 1.48
9334	9210	Controller-to-1/2 inch, 9-track tape drive (7015 system) or Controller-to-9334-010	00G1278	4.75

Note: The 70F9733, 71F1072, and 71F1073 cables are no longer manufactured, but are still usable, the 70F9733 is limited to four external devices maximum.

Device Internal Cable Lengths

Device	Cable Length (meters)
7203, 7204, 7206,-1 7207, 7208, 7209-1, 7210	Negligible
7206-5, 7209-2	.25
9348	Negligible
9334-010	1.0
9334-500	2.66
7015 Media Drawer	3.1

Device-to-Device Cables

MT	F/C	Cable Description	Part Number	Cable Length (meters)
Host System	3130	Device-to-device (where second device has one connector)	70F9734/ 31F4222	0.66
7204-010 7206-005 7209-002 7210-005	2840/ 9126	Device-to-device (where second device has two connectors)	33F4607	0.7

Note: The 70F9734 cable is no longer manufactured, but still usable if no more than 4 external devices are attached.

Terminators for Use with this Controller

Card Edge

An SCSI card edge terminator is required when no internal cable or SCSI device is attached. This terminator is installed on the top edge of the SCSI card.

Terminator Description	Part Number
Card edge, non-FPT	70F9900
Card edge, FPT-3	00G0972

Note: The 70F9900 terminator is no longer manufactured, but still usable if no more than 2 external devices are attached.

Card External

A SCSI card external terminator is required when no external cable or SCSI device is attached. This terminator attaches to the SCSI card external bus connector on the rear edge of the SCSI card.

Terminator Description	Part Number
60-pin, external	15F6743

Single-Ended External

An SCSI external terminator is required when any external cable or SCSI device is attached. This terminator is attached at the external end of the bus.

Terminator Description	Part Number
50-pin, Low-density, external, non-FPT	70F9671
50-pin, Low-density, external, FPT-3	00G0968
50-pin, Low-density, external, FPT18C	52G4260

Notes:

1. The 70F9671 terminator is no longer manufactured, but it is still usable if no more than four external devices are attached.
2. The 52G4260 terminator was released as a common replacement for all of the single-ended terminators. It replaces the FPT-3 part number 00G0968, the FPT-18 part number 43G0467, and the FPT-18 part number 51G7736. All of these terminators are still usable; new installations and field replacements are supplied with the new 52G4260 terminator.

Cabling Examples

Example 1:

Connect a 7207 1/4-inch tape drive and a 7010 CD-ROM to a 7013/530 system; there are two SCSI devices inside the covers, already connected to the SCSI card.

Solution:

From the tables on the previous two pages, the following cable lengths are obtained:

• System Internal SCSI Cable Lengths: internal length	3.67 m
• SCSI Device Internal Cable Length: 7207 internal length	negligible
• SCSI Device Internal Cable Length: 7210 internal length	negligible
• SCSI External Cable length: controller-to-first-device(31F4221)	1.57
• SCSI External Cable length: device-to-device (31F4222)	0.66 m
Total	5.90 m

The internal cable has a terminator on the end of the bus, internal to the system unit. Terminator (P/N 00G0968) should be connected after the last external device to terminate the other end of the bus. Note that a third external device cannot be connected on this bus, as the length would exceed 6 meters.

Example 2:

Connect a 7207 1/4-inch tape drive and a 7210 CD-ROM to a 7013/530 system that already has seven devices connected to the base SCSI controller.

Solution:

Add another controller as follows. From the SCSI length tables on previous pages, the following cable lengths are obtained:

• SCSI Device Internal Cable Length: 7207 internal length	negligible
• SCSI Device Internal Cable Length: 7210 internal length	negligible
• SCSI External Cable length: controller-to-first-device(31F4221)	1.57
• SCSI External Cable length: device-to-device (31F4222)	0.66 m
Total	2.23 m

An SCSI card edge terminator (PN 00G0972) should be attached to the top edge connector of a second SCSI card, in order to terminate the end of the bus at the SCSI controller. Terminator (PN 00G0968) should be connected after the last external device to terminate the other end of the bus.

Example 3:

Add an internal 400MB disk drive to a 7012/32H system that already has one internal 320MB disk drive on the SCSI bus.

Solution:

- Connect the 400MB disk drive to the SCSI bus.

From the SCSI length tables on previous pages, the following cable lengths are obtained:

• SCSI Device Internal Cable Length: 7012 internal length	0.5 m
Total	0.5 m

The internal cable already should have a terminator on the bus end that is internal to the system unit. A second terminator (PN 15F6743) should already be connected to the SCSI controller external bus connector terminating the other end of the bus.

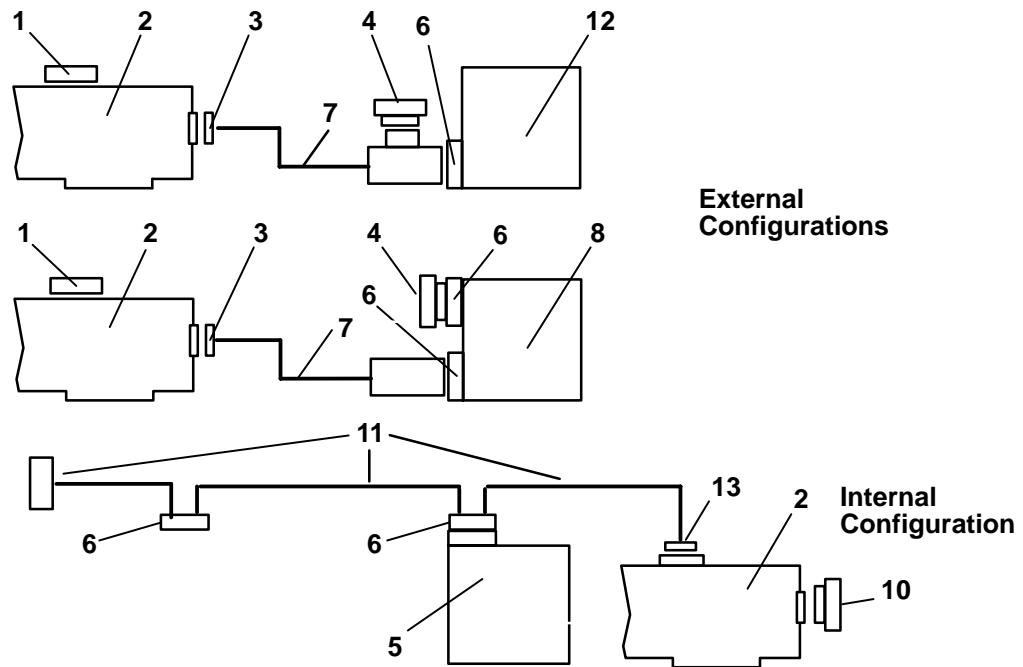

Item Number	SCSI-1 Part Number	SCSI-2 Part Number	Description
1	00G0972	00G0972	50-position card edge terminator
2	51G9425		SCSI-1 I/O controller (labelled "4-1" near external connector)
		52G7509 11H4779	SCSI-2 I/O controller (labelled "4-4" near external connector)
3			60-position SCSI-1/50-position SCSI-2 connector
4	00G0968 or 52G4260	51G7736 or 52G4260	50-position SCSI external terminator
5			One-connector type SCSI internal device
6			50-position SCSI connector
7	31F4221 70F9733	32G0397	Dual-connector type controller-to-device SCSI cable (attaches single connector devices)
	33F4606	8191425	Single-connector type controller-to-device cable (attaches two connector devices)
8			Two-connector type SCSI devices
10	15F6743		60-position SCSI external terminator
	51G7737 or 52G4259		50-position high-density SCSI-2 single-ended external terminator

Item Number	SCSI-1 Part Number	SCSI-2 Part Number	Description
11			Internal SCSI disk drive cable and terminator assembly
12			One-connector type SCSI device
13			50-position card edge SCSI connector

Attaching Multiple SCSI Single-Ended Devices

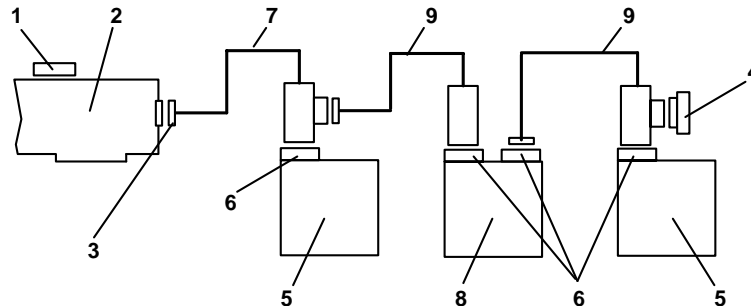

Item Number	SCSI-1 Part Number	SCSI-2 Part Number	Description
1	00G0972	00G0972	50-position card edge terminator
2	51G9425		SCSI-1 I/O controller (labelled "4-1" near external connector)
		52G7509 11H4779	SCSI-2 I/O controller (labelled "4-4" near external connector)
3			60-position SCSI-1/50-position SCSI-2 connector
4	00G0968 or 52G4260	51G7736 or 52G4260	50-position SCSI external terminator
5			One-connector type SCSI internal device
6			50-position SCSI connector
7	31F4221 or 70F9733	32G0397	Dual-connector type controller-to-device SCSI cable (attaches single connector devices)
8			Two-connector type SCSI device
9	31F4222	31F4222	Dual-connector type device-to-device cable (attaches single connector devices)
	33F4607	33F4607	Single-connector type device-to-device cable (attaches two connector devices)

High-Availability SCSI-1 and SCSI-2 Single-Ended Cabling

Attention: The following high-availability section describes supported hardware configurations. These configurations may not be supported by your software application. Be sure that your software application supports these configurations before attempting to use them.

Note: The passthrough terminator cables are no longer available except through RPQ 8A0759 for the SCSI-1 controller and RPQ 8A0758 for the SCSI-2 controller. The recommended high-availability SCSI configuration is the SCSI-2 differential controller and subsystems.

The high-availability configuration has important prerequisites:

- No internal SCSI single-ended devices may be attached to either SCSI single-ended controller used in the high-availability configuration.

Note: 1. The integrated SCSI function found on the planar of certain models, such as 7012/340/350, cannot be used for high-availability. To achieve high-availability on these models, separate SCSI-1 Single-Ended, SCSI-2 single-ended, or SCSI-2 differential controllers must be used.
2. The recommended high-availability SCSI configuration is the SCSI-2 differential controller and differential subsystem.

- No internal terminators may be used on either SCSI single-ended I/O Controller.
- Jumper J1 (2 pieces) or P3 (2 pieces) must be moved, refer to Chapter 1, "Adapter Information" on page 1-1.
- A Passthrough Terminator, Controller-to-First-Device Cable must be used from each SCSI single-ended I/O Controller to the first SCSI single-ended device at each end of the device chain. (Only available through RPQ.)
- High-availability software must be installed on both system units.
- A specific device-to-device cable (listed below) should be used.

Note: The termination of the SCSI single-ended chain is continued by the Passthrough Terminator in the event that one host becomes disconnected.

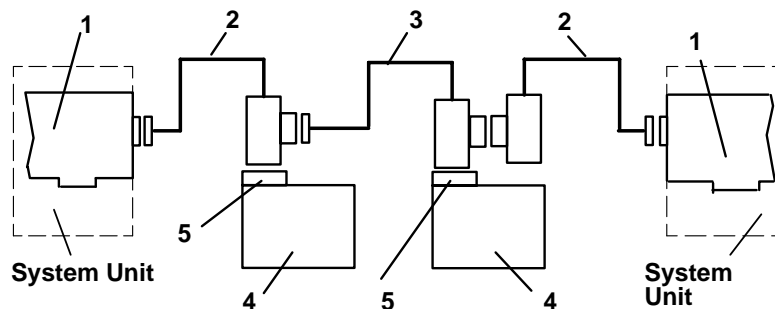

Item Number	SCSI-1 Part Number	SCSI-2 Part Number	Description
1	51G9425		SCSI-1 I/O controller (labelled "4-1" near external connector)
		52G7509 11H4779	SCSI-2 I/O controller (labelled "4-4" near external connector)
2	00G0959	51G8568	Passthrough Terminator, Controller-to-First- Device Cable
	70F9171		9334/500 attachment
3	31F4222	31F4222	Device-to-device cable for single connector devices
4			One-connector type SCSI device
5			50-position SCSI connector

Cabling the SCSI-2 Fast/Wide Integrated Controller for Machine Type 7012 Models 380/390/39H and 7030 Models 3AT/3BT/3CT

To understand the cabling for this controller, read "General SCSI Considerations" on page 4-5, then read the following for specific information.

There are two unique considerations when cabling this controller:

- There are actually two separate SCSI controllers, thus enabling the internal and external SCSI buses to be completely independent. Because of this independence, the internal cable length and number of internally attached devices need not be considered when cabling external devices. This is different from previous designs and makes cabling considerations simpler.
- The internal bus is a 16-bit bus and the external bus is a 16-bit bus.

Physical differences between the wide bus (16-bit) and the narrow bus (8-bit) are:

Wide Bus (16-bit)	Narrow Bus (8-bit)
Uses a 68 conductor cable.	Uses a 50 conductor cable.
Can attach either wide (16-bit) or narrow (8-bit) devices to the internal bus (narrow devices only have narrow (8-bit) performance). Can attach either all wide or all narrow devices to the external bus.	Can only attach to narrow devices.
4 address bits, allowing for 16 unique addresses.	3 address bits, allowing for 8 unique addresses.

Note: AIX 3.2.5 with the appropriate PTFs supports only SCSI IDs from 0 to 7, limiting the number of device attachments to 7 per bus. The default SCSI address of this controller is 7.

SCSI-2 Single-Ended External Cable Lengths Using This Controller

SCSI-2 single-ended cabling should be accomplished in accordance with the following criteria and machine-type specifications. SCSI cable length maximums must be carefully observed to avoid transmission line mismatch problems.

Due to increased maximum data rates in systems with SCSI-2 fast devices, the SCSI-2 single-ended bus length is 3 meters (9.9 ft) maximum. This maximum length includes the internal cabling of a device that has two connectors. All configurations incorporating OEM devices are restricted to a 3 meter (9.9 ft) maximum length. However, certain configurations using supported devices with specialized termination allow longer bus lengths. The following bulleted items indicate the only supported configurations that are longer than 3 meters:

- With this integrated controller, an SCSI bus length of 3.75 m (12.3 ft) may be achieved using part numbers 52G4231 or 92F2559 and 31F4222 or 35F4607 to attach up to 4 external (supported) SCSI devices in a narrow bus implementation.
- With this integrated controller a maximum SCSI bus length of 5.04 m (16.53) may be achieved using part number 52G4232 or 88G5755 to attach a 9334/500 to a 7012 system.

Note: Appropriate terminators are also required.

Cable and Terminator Tables for the SCSI-2 Single-Ended Fast/Wide Integrated Controller

The following tables and examples are provided as an aid to properly cable an SCSI-2 single-ended bus.

System Internal Cable Lengths

Because this controller has separate internal and external SCSI buses, the internal cable lengths need not be considered when attaching external SCSI devices.

Controller-to-First Device Cables

Refer to “Controller-to-First Device Cables” on page 4-41.

Device Internal Cable Lengths

Refer to “Device Internal Cable Lengths” on page 4-9 for information on narrow bus devices.

Device-to-Device Cables

Refer to “Device-to-Device Cables” on page 4-9 for information on narrow bus cables, or on page 4-42 for information on wide bus cables.

Terminators for Use with This Controller

Internal Cabling

This controller has an onboard terminator for the internal bus; if the internal bus is not used, there is no need for additional internal terminators. If the internal bus is used, terminator P/N 88G3977 should be attached at the end of the internal cable.

External Cabling

The controller has an onboard terminator for the external bus; no additional external terminators are needed if this bus is not being used.

An SCSI-2 single-ended external terminator is required when any external cable or device is attached. Refer to Terminator Description table on page 4-42.

Cable Examples for the SCSI-2 Single-Ended Fast/Wide Integrated Controller

The cable examples in the section “Cable Examples for the SCSI-2 Single-Ended Fast/Wide Controller” on page 4-44 can be used as a reference for internal and external device attachments.

High-Availability SCSI-2 Integrated Controller

High-availability is not supported with this controller.

Cabling the SCSI-1 Integrated Controller for Machine Types 7012, 7013, and 7015

To understand the cabling for this controller, read "General SCSI Considerations" on page 4-5, then read the following for specific information.

SCSI-1 Single-Ended Cable Lengths Using this Controller

SCSI-1 single-ended cabling should be accomplished in accordance with the following criteria and machine type specifications.

Note: SCSI cable length maximums must be carefully observed to avoid transmission line mismatch problems.

- The maximum length of a chain of SCSI devices and cables is 6 m (19.7 feet). This maximum length includes the internal cabling of a device that has two connectors.
- For systems with both internal and external cables, the 6 m (19.7 feet) maximum is defined as the distance from the internal terminator to the external terminator.

Cable and Terminator Tables for the SCSI-1 Integrated Controller

The following tables and examples are provided as an aid to properly cable an SCSI bus.

System Internal Cable Lengths

Machine Type	F/C	Description	Cable Length (meters)
7012-340 to 375	*	Integrated SCSI cable	0.5
7013-(all except 550L), 570 and 580 shipped before 7/1/93	*	Integrated SCSI cable	3.45
7013-550L	*	Integrated SCSI cable	3.85
7013-580/58H/590 shipped after 7/1/93	*	Integrated SCSI cable	1.95

Controller-to-First Device Cables

MT	F/C	Cable Description	Part Number	Cable Length (meters)
Host System	2833	Integrated SCSI controller-to-first-device (where first device has one connector)	32G0397	1.57
7204-010 7206-005 7209-002 7210-005	2838/ 9124	Integrated SCSI controller-to-first-device (where first device has two connectors)	8191425	1.5
9334	2918	Integrated SCSI controller-to-9334/500	70F9188	1.48

Device Internal Cable Lengths

Refer to "Device Internal Cable Lengths" on page 4-9.

Device-to-Device Cables

Refer to "Device-to-Device Cables" on page 4-9.

Terminators for Use with this Controller

This controller has an internal terminator built into the controller.

Controller Output Connector

An SCSI card external terminator is required when no external cable or SCSI device is attached. This terminator attaches to the SCSI controller external bus connector on the rear edge of the box.

Terminator Description	Part Number
50-pin, high-density, external, FPT-3	00G2223
50-pin, high-density, external, FPT18C	52G4259

Note: The 52G4259 terminator was released as a common replacement for all of the single-ended terminators. It replaces the FPT-3 part number 00G2223, part number 51G7737, and the FPT-18 part number 43G0378. All of these terminators are still usable; new installations and field replacements are supplied with the new 52G4259 terminator.

SCSI-1 Single-Ended External

An SCSI external terminator is required when any external cable or SCSI device is attached. This terminator is attached at the external end of the bus.

Terminator Description	Part Number
50-pin, low-density, external, non-FPT	70F9671
50-pin, low-density, external, FPT-3	00G0968
50-pin, low-density, external, FPT18C	52G4260

Note: The 52G4260 terminator was released as a common replacement for all of the single-ended terminators. It replaces the FPT-3 part number 00G0968, the FPT-18 part number 43G0467, and the FPT-18 part number 51G7736. All of these terminator are still usable; new installations and field replacements are supplied with the new 52G4260 terminator.

Cable Examples for the Integrated Controller

The cable examples in “Cabling Examples” on page 4-10 can be used as reference for device-to-device attachment. Substitute the above integrated controller-to-device cables for the controller-to-device cables in the examples.

High-Availability SCSI-1 Integrated Controller

High-availability is not supported with this controller.

Cabling the SCSI Integrated Controller for Machine Types 7006, 7008, 7009, and 7011

Note: To understand the cabling for this controller, read “General SCSI Considerations” on page 4-5, then read the following for specific information.

SCSI Single-Ended Cable Lengths

SCSI single-ended cabling should be accomplished in accordance with the following criteria and machine type specifications. The maximum lengths stated below include the internal cabling of any device that has two connectors.

- For the 7006, and 7009 controllers, the total cable length is limited to 3 m (9.8 ft) which allows a maximum of two external devices.
- For the 7008 and 7011-220/230 controllers, the maximum cable length is 6 m (19.7 ft).
- For 7011-250 controllers, if any SCSI-2 device is attached, the total cable length is limited to 3 meters which allows a maximum of 3 external devices. If only SCSI-1 devices are attached (internally or externally) on the SCSI bus the total cable length is limited to 6 m (19.7 ft).

Cable and Terminator Tables for this Controller

The following tables and examples aid in properly cabling a SCSI bus.

System Internal Cable Lengths

Machine Type	Notes	Cable Length (meters)
7006	Integrated SCSI length	.76
7008	Integrated SCSI length	Negligible
7009	Integrated SCSI length	.76
7011	Integrated SCSI length	.2

Note: These controllers have an internal terminator.

Controller-to-First Device Cables

MT	F/C	Cable Description	Part Number	Cable Length (meters)
Host System	2833	Integrated SCSI controller-to-first-device (where first device has one connector)	32G0397	1.57
7204-010 7206-005 7209-002 7210-005	2839/9125	Integrated controller-to-first-device (where first device has two connectors)	8191425	1.5

Device Internal Cable Lengths

Refer to "Device Internal Cable Lengths" on page 4-9.

Device-to-Device Cables

Refer to "Device-to-Device Cables" on page 4-9.

Terminators for Use with This Controller

The single-ended controller has an internal terminator built into the controller.

Controller Output Connector

An SCSI card external terminator is required when disk drive is installed in the box and no external cable or SCSI device is attached. This terminator attaches to the SCSI controller external bus connector on the rear edge of the box.

Terminator Description	Part Number
50-pin, high-density, external, FPT-18	43G0378
50-pin, high-density, external, FPT-18+	51G7737
50-pin, high-density, external, FPT18C	52G4259

Note: The 52G4259 terminator was released as a common replacement for all of the single-ended terminators. It replaces the FPT-3 part number 00G2223, part number 51G7737, and the FPT-18 part number 43G0378. All of these terminators are still usable; new installations and field replacements are supplied with the new 52G4259 terminator.

SCSI-1 Single-Ended External

An SCSI external terminator is required when any external cable or SCSI device is attached. This terminator is attached at the external end of the bus.

Terminator Description	Part Number
50-pin, low-density, external, FPT-18	43G0467
50-pin, low-density, external, FPT-18+	51G7736
50-pin, low-density, external, FPT18C	52G4260

Note: The 52G4260 terminator was released as a common replacement for all of the single-ended terminators. It replaces the FPT-3 part number 00G0968, the FPT-18 part number 43G0467, and the FPT-18 part number 51G7736. All of these terminators are still usable; new installations and field replacements are supplied with the new 52G4260 terminator.

Cabling Examples

The cable examples in “Cabling Examples” on page 4-10 can be used for reference for device-to-device attachment. Substitute the above integrated controller-to-device cables for the controller-to-device cables in the examples. Use the above terminators in place of the terminators in the examples

High-Availability with this Controller

High-availability is not supported with this controller.

Cabling the SCSI-2 Single-Ended Controller FC 2831 and 2410

To understand the cabling for this controller, read “General SCSI Considerations” on page 4-5, then read the following for specific information.

SCSI-2 Single-Ended Cable Lengths Using this Controller

SCSI-2 single-ended cabling should be accomplished in accordance with the following criteria and machine type specifications.

Note: SCSI-2 single-ended cable length maximums must be carefully observed to avoid transmission line mismatch problems.

- Due to increased maximum data rates, the SCSI-2 single-ended bus length is specified to be 3 m (9.9 ft.) maximum. This maximum length includes the internal cabling of a device that has two connectors. All configurations incorporating OEM devices are restricted to 3 m maximum length. However, certain configurations with specialized termination allow longer bus lengths. The following configurations are the only supported configurations that are longer than 3 meters.

Note: The following referenced part numbers are cables only; terminators are also required.

For cable lengths and feature codes a specific reference is listed immediately following the cable part number. If no reference is made immediately following the part number, see “Cable and Terminator Tables for SCSI-2 Single-Ended Controller” on page 4-25.

- An SCSI bus length of 3.75 m (12.3 ft) may be achieved using Part Numbers 32G0397 and 31F4222/33F4607 (refer to “Device-to-Device Cables” on page 4-9) to attach up to four external, supported SCSI devices to a 7011, 7012 or 7013 system.
- An SCSI bus length of 4.25 m (13.9 ft) may be achieved using Part Numbers 51G857 (or 52G7451) an internal six-drop cable, 32G0397, and 31F4222 to attach up to two supported SCSI devices on the external bus, together with up to six SCSI devices on the internal bus, to a 7013 system.
- An SCSI bus length of 5.2 m (17.1 ft) may be achieved using Part Number 45G2858 to attach a 9334-500 to a 7011, 7012 or 7013 system.
- An SCSI bus length of 5.5 m (18 ft) may be achieved using Part Number 45G2858 to attach to a 6100 Drawer containing only new feature code 2555 1GB disk drives (1GB disk drives shipped before 8/17/93 do not work), or feature code 2580 2GB disk drives, or any SCSI-1 disk drives.
- A SCSI bus length of 5.9 m (19.3 ft) may be achieved using Part Number 51G8569 to attach a 9334-010 to a 7015 system.

Note: The total number of attached SCSI devices must be seven or fewer.

- For systems with both internal and external cables, the maximum length is defined as the distance from the internal terminator to the external terminator.

Cable and Terminator Tables for SCSI-2 Single-Ended Controller

The following tables and notes aid in properly cabling an SCSI-2 single-ended bus. For diagram examples, refer to pages 4-12 and 4-13.

System Internal Cable Lengths

The SCSI-2 Single-Ended controller is included with the 7013-580's that were shipped after 7/1/93. Only two external devices can be attached to this controller using part numbers from table "Controller-to-Device Cables" and part numbers from table "Device-to-Device Cables" on page 4-9 to attach the external devices.

The SCSI-2 Single-Ended controller is included with all 970B's and 980B's to drive the internal disk drives, no external devices can be attached to this controller.

Internal Cables for 5XX Models

MT	F/C	Cable Description	Part Number	Cable Length (meters)
SCSI-2 Controller	2831	Internal six-drop cable and attached terminator	52G7451	1.86
*	*	Internal six-drop cable and attached terminator	51G8571	1.81
Note: * This cable has been replaced by 52G7451.				

Controller-to-Device Cables

MT	F/C	Cable Description	Part Number	Cable Length (meters)
Host System	2836	Controller-to-first-device (where first device has one connector)	32G0397	1.57
7204-010 7206-005 7209-002 7210-005	2838/ 9124	Controller-to-first-device (where first device has two connectors)	8191425	1.57
9334	9211	Controller-to-9334-010	51G8569	4.75
	2920	Controller-to-9334-500	45G2858	2.38

Device Internal Cable Lengths

Refer to "Device Internal Cable Lengths" on page 4-9.

Device-to-Device Cables

Refer to "Device-to-Device Cables" on page 4-9.

Terminators for Use with this Controller

Card Edge

An SCSI-2 single-ended card edge terminator is required when no internal cable is attached. This terminator is installed on the top edge of the SCSI card.

Terminator Description	Part Number
Card edge, FPT-3	00G0972

Card External

An SCSI-2 single-ended card external terminator is required when no external cable is attached. This terminator attaches to the SCSI single-ended card external bus connector on the rear edge of the SCSI-2 single-ended card.

Note: The SCSI-2 single-ended controller is labelled "4-4" near the external connector, and the terminator is labelled "SCSI-2 SE".

Terminator Description	Part Number
50-pin, high-density, external, FPT-18+	51G7737
50-pin, high-density, external, FPT18C	52G4259

Note: The 52G4259 terminator is used in place of the 51G7737 terminator; the 51G7737 terminator is still usable.

External Terminator

An SCSI-2 single-ended external terminator is required when any external cable or device is attached (except for 9334/010 attachment or high-availability configuration). This terminator is attached at the external end of the bus, and is labelled "SCSI-2 SE".

Terminator Description	Part Number
50-pin, low-density, external, FPT-18+	51G7736
50-pin, low-density, external, FPT18C	52G4260

Note: The 52G4260 terminator is used in place of the 51G7736 terminator; the 51G7736 terminator is still usable.

Cabling Examples for the SCSI-2 Single-Ended Controller

Refer to "Cabling Examples" on page 4-10.

High-Availability SCSI-2 Single-Ended Cabling

Attention: The following high-availability section describes supported hardware configurations. These configurations may not be supported by your software application. Be sure that your software application supports these configurations before attempting to use them.

Note: Passthrough terminator cables are no longer available except through RPQ 8A0758 for the SCSI-2 controller. The recommended high-availability SCSI configuration is the SCSI-2 differential controller and subsystems.

The high-availability configuration has important prerequisites:

- No internal SCSI single-ended devices may be attached to either SCSI single-ended controller used in the high-availability configuration.
- No internal terminators may be used on either SCSI single-ended I/O Controller.
- Jumper P3 (2 pieces) must be moved.
- High-availability software must be installed on both system units.

Note: The only approved high-availability configuration using this Controller is using the following cables to attach up to two external supported SCSI devices that are shared by any two 7011, 7012, or 7013 systems.

MT	F/C	Cable Description	Part Number	Cable Length (meters)
*	N/A	Passthrough terminator, controller-to-device	51G8568	1.57
Host System	3130	Device-to-device	31F4222	.66

* This cable is available only as an RPQ.

Note: See cabling examples in “High-Availability SCSI-1 and SCSI-2 Single-Ended Cabling” on page 4-14.

Cabling the SCSI-2 Differential I/O Controller FC 2420

SCSI-2 I/O controllers may be of single-ended or differential SCSI bus signal driver design. Differential devices cannot be attached to single-ended controllers and single-ended devices cannot be attached to differential controllers.

Identifying SCSI-2 Differential Components

Note: SCSI controllers, devices, enclosures, and cables that are not marked with reference to single-ended or differential design should be considered as single-ended.

- Differential controllers are labeled Differential SCSI on the rear controller bracket.
- Differential devices are labeled Differential SCSI as near as possible to the appropriate connector.
- Differential enclosures are labeled Differential SCSI as near as possible to appropriate internal and external connectors. Differential enclosure access panels that must be removed to allow access to devices or cables are labeled: All internal SCSI devices and cables are Single-ended SCSI.

OEM Components

OEM devices may be marked with one of the following ANSI icons:

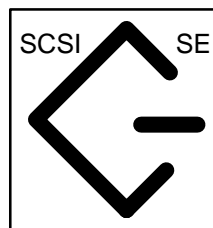

Single-Ended

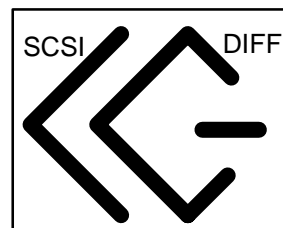

Differential

SCSI-2 Differential Bus Lengths Using This Controller

Differential SCSI bus length is defined as the distance between terminators at either end of a SCSI bus.

- For configurations using external cabling, length restrictions refer to the length from the built-in differential terminator on the controller to the last device on the external SCSI bus.
- Devices that have two connectors, such as the 9334-011/501, have internal cabling that must be included when calculating total cable length. When connecting these devices, connect one cable into one connector and the other cable (or terminator if this is the last device on the bus) to the second connector. Up to two 9334-011/501 may be connected on one SCSI-2 differential bus.
- The SCSI-2 differential bus length should be no longer than 19m (62.3 ft.).

Cable and Terminator Tables for the SCSI-2 Differential Controller

SCSI-2 differential cabling should be accomplished in accordance with the following criteria and machine type specifications.

SCSI-2 differential cable length maximums must be carefully observed to avoid transmission line mismatch problems.

Use the 2xxx feature codes listed in the following tables to order just the cable or terminator. Use the 9xxx feature codes to order a cable or terminator as a select feature for the SCSI device you are attaching. These cables and terminator may also be provided with other feature codes.

System Differential Internal Cable Lengths

There are no internal connections to the SCSI-2 differential controller.

Controller-to-First-Device Cables

MT	F/C	Cable Description	Part Number	Cable Length (meters)
7204-2xx	2854/9138	Controller-to-7204-2xx differential device (8-bit)	87G1358	0.6
	2921/9221		67G0593	4.75
9334	2921/9221	Controller-to-9334-011 differential device (8-bit)	67G0593	4.75
	2923/9223		95X2494	8.0
9334	2931	Controller-to-9334-501 deskside differential unit (8-bit)	67G0589	1.48
	2933		67G0590	2.38
	2935		67G0566	4.75
	2937		67G0562	8.0
7135	2902/9202	Controller-to-7135 (16-bit)	67G1260	2.4
	2905/9205		67G1261	4.5
	2912/9212		67G1262	12.0
	2914/9214		67G1263	14.0
	2918/9218		67G1264	18.0
	2919	Interposer required to attach cable.	61G8323	N/A

Differential Device Internal Cable Lengths

Device	Cable Length (meters)
9334/011	3.1
9334/501	2.66
7204	0.25
7134	2.7
7135	.66

Differential Device-to-Device Cables

MT	F/C	Cable Description	Part Number	Cable Length (meters)
7204-2xx	2848/9134	7204-to-7204 differential device cable (8-bit)	74G8511	.66
9334	2925/9225	9334-011-to-9334-011 differential (8-bit)	95X2492	2.0
9334	2939/9239	9334-501-to-9334-501 differential device cable (8-bit)	95X2498	2.0
7135	2901/9201	7135-to-7135 (16-bit)	67G1259	.6

Differential Terminators for Use with This Controller

- Each end of the bus must have a terminator; that is, there are only two terminators on the bus.
 - The SCSI-2 Differential High Performance External I/O Controller (Type 4-2) has built-in, removable differential terminators. One additional external terminator is required when connecting devices to the external SCSI bus.

F/C	Terminator Description	Part Number
2847/ 9133	50-pin, low-density, external, narrow bus (8-bit)	79X3795/87G1356
	68-pin, external, wide bus (16-bit)	61G8324

Cabling Examples for the SCSI-2 Differential Controller

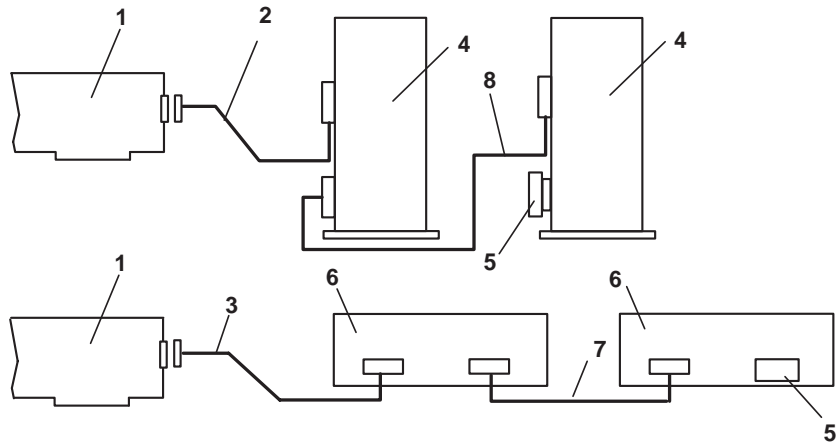

Item Number	Part Number	Description	Cable Length (meters)
1	43G0176 11H2447	SCSI-2 Differential High-Performance External I/O Controller (Type 4-2 labeled 4-2 near the external connector)	N/A
2	67G0566	Controller-to-first 9334-501 deskside differential unit,	4.75
	67G0562	Controller-to-first 9334-501 deskside differential unit,	8.0
3	67G0593	Controller-to-9334-011 or 7204 differential unit,	4.75
	95X2494	Controller-to-9334-011 or 7204 differential unit,	8.0
4		9334-501 deskside differential unit	N/A
5	79X3795	External differential terminator, 50-pin, low-density, 9334-011/501	N/A
6		9334-011 or 7204 differential device	N/A
7	95X2492	9334-011 or 7204 differential device-to-9334-011	N/A
	95X2498	or 7204 differential device cable,	2
8		9334-501 deskside differential unit-to-9334-501 deskside differential unit cable,	2

Special Cabling Considerations for the 7135 RAIDiant Array

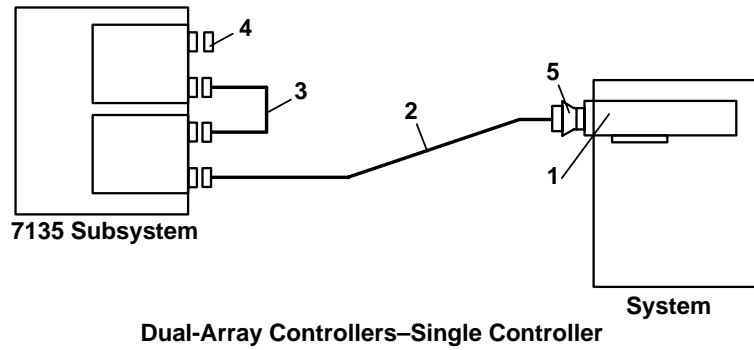

Item Number	Part Number	Description	Cable Length meters
1	43G0176 11H2447	SCSI-2 Differential High-Performance External I/O Controller (Type 4-2 labeled 4-2 near the external connector)	N/A
2	67G1263	Cable, controller-to-7135,	14
3	67G1259	Cable, array-controller-to-array-controller,	0.6
4	61G8324	Terminator, differential, 68-pin	N/A
5	61G8323	Interposer, 68-pin to 50-pin interface	N/A

Note: For item 2, a shorter cable can be used. Refer to “Controller-to-First-Device Cables” on page 4-29 under 7135.

High-Availability Configuration SCSI-2 Differential Cabling

Attention: The following high-availability section describes supported hardware configurations. These configurations may not be supported by your software application. Be sure that your software application supports these configurations before attempting to use.

The high-availability configuration is implemented with the SCSI-2 Differential High-Performance External I/O Controller (Type 4-2) by plugging the middle leg connector of the high-availability configuration Y-cable into the controller external 50-pin connector and by removing the two built-in differential terminator resistors from the controller. The two top legs of the high-availability configuration Y-cable plug into the SCSI bus.

If the SCSI-2 Differential High-Performance External I/O Controller (Type 4-2) is at the end of the SCSI bus, the shorter top leg of the high-availability configuration Y-cable must be terminated with the differential high-density 50-pin terminator, part number 52G7350.

Notes: The high-availability configuration (Y-cable with a terminator on the shorter top leg) permits the controller to be disconnected from the SCSI bus by removing the 50-pin external bus connection (middle leg of the Y-cable). Although the SCSI bus continuity is maintained during removal of the controller, noise generated may create undetected bus errors if the bus is in use. To maintain data integrity, the SCSI bus should be quiesced during the removal of controllers, devices, terminators, or cables.

High-availability software must be installed on both system units.

Cables for High-Availability and Target Mode

MT	F/C	Cable Description	Part Number	Cable Length (meters)
Host System	2422	Y-cable (8-bit)	52G7348	.765
Host System	2423	System-to-system Cable (Target mode environment) 8-bit	52G7349	2.5

Terminator for High-Availability and Target Mode

F/C	Cable Description	Part Number
*	50-pin high-density (connects to Y-cable)	52G7350
Note: * Included in F/C 2422		

Cabling Examples for High-Availability SCSI-2 Differential Configurations

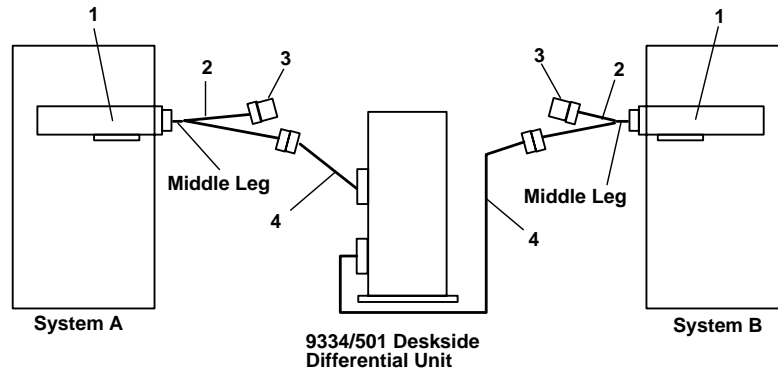

Item Number	Part Number	Description	Cable Length (meters)
1	43G0176 11H2447	SCSI-2 Differential High-Performance External I/O Controller (Type 4-2 labelled 4-2 near the external connector)	N/A
2	52G7348	Y-cable, differential, high-availability configuration, (total, all legs)	0.765
3	52G7350	Differential terminator, high-availability configuration Y-cable, 50-pin, high-density	N/A
4	67G0566	Cable, controller-to-first 9334-501 deskside differential unit	4.75

Notes:

1. When a Y-cable is used, the internal terminator on the controller card must be removed.
2. For item 4, other cables can be used as long as the total bus length is kept to 19 meters or less. Refer to "Controller-to-First-Device Cables" on page 4-29 under 9334-501.

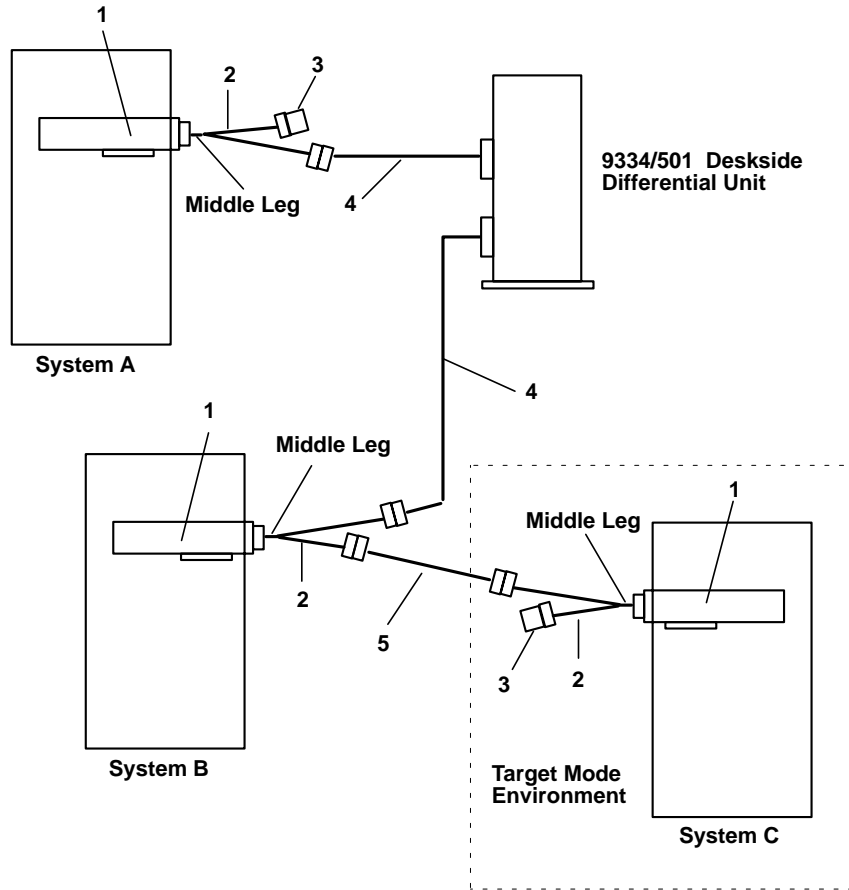

Item Number	Part Number	Description	Cable Length (meters)
1	43G0176 11H2447	SCSI-2 Differential High-Performance External I/O Controller (Type 4-2 labelled 4-2 near the external connector)	N/A
2	52G7348	Y-cable, differential, high-availability configuration, (total, all legs)	0.765
3	52G7350	Differential terminator, high-availability configuration Y-cable, 50-pin, high-density	N/A
4	67G0566	Cable, controller-to-first 9334-501 deskside differential unit,	4.75
5	52G7349	Cable, system-to-system, SCSI-2 differential,	2.5

Notes:

1. When a Y-cable is used, the internal terminator on the controller card must be removed.
2. For item 4, other cables can be used as long as the total bus length is kept to 19 meters or less. Refer to "Controller-to-First-Device Cables" on page 4-29 under 9334-501.

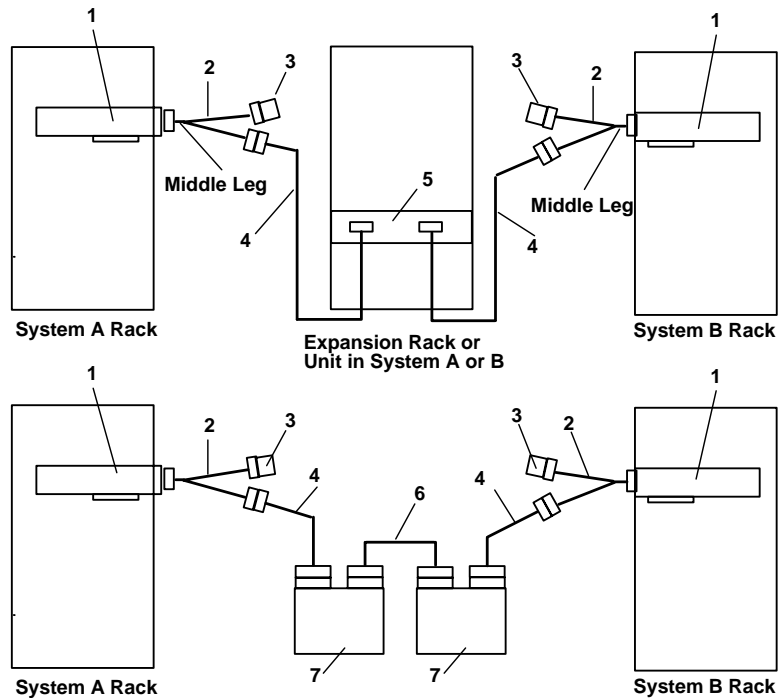

Item Number	Part Number	Description	Cable Length (meters)
1	43G0176 11H2447	SCSI-2 Differential High-Performance External I/O Controller (Type 4-2 labelled 4-2 near the external connector)	N/A
2	52G7348	Y-cable, differential, high-availability configuration, (total, all legs)	0.765
3	52G7350	Differential terminator, high-availability configuration Y-cable, 50-pin, high-density	N/A
4	67G0593	Cable, controller-to-first 9334-011 or 7204 differential device,	4.75
5		9334-011 differential drawer	N/A
6	95X2492	9334-011 differential drawer-to-9334-011 differential drawer or 7204 differential unit to 7204 differential unit cable,	2
7		7204 differential unit	N/A

Notes:

1. When a Y-cable is used, the internal terminator on the controller card must be removed.
2. For item 4, other cables can be used as long as the total bus length is kept to 19 meters or less. Refer to "Controller-to-First-Device Cables" on page 4-29 under 9334-011.

Special Cabling Considerations for the 7135 RAIDiant Array

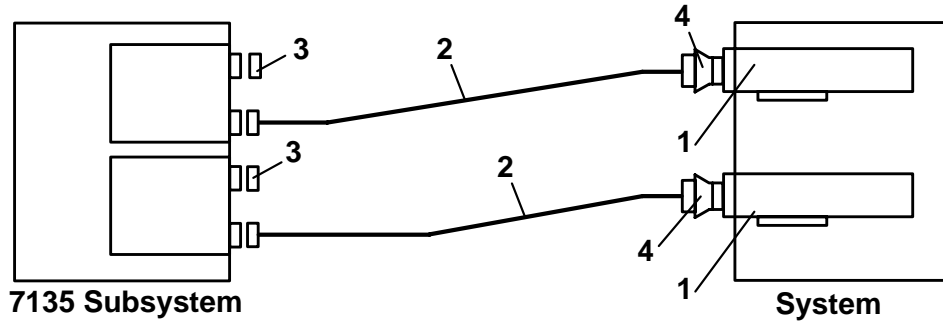

Dual-Array Controllers–Dual SCSI Controllers–Single Host

Item Number	Part Number	Description	Cable Length (meters)
1	43G0176 11H2447	SCSI-2 Differential High-Performance External I/O Controller (Type 4-2 labeled 4-2 near the external connector)	N/A
2	67G1264	Cable, controller-to-7135,	18

Note: For item 2, a shorter cable can be used. Refer to “Controller-to-First-Device Cables” on page 4-29 under 7135.

Special Cabling Considerations for the 7135 RAIDiant Array (continued)

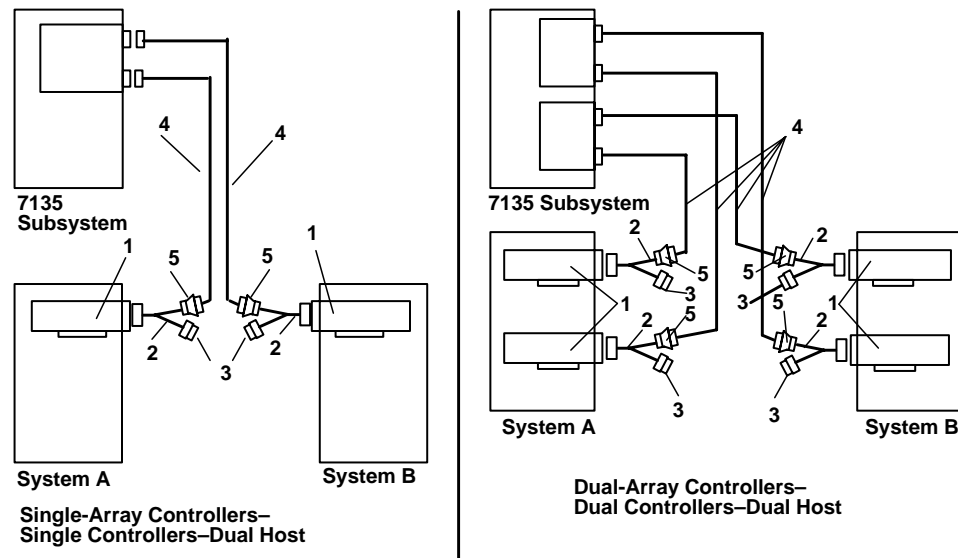

Item Number	Part Number	Description	Cable Length (meters)
1	43G0176 11H2447	SCSI-2 Differential High-Performance External I/O Controller (Type 4-2 labeled 4-2 near the external connector)	N/A
2	52G7348	Y-cable, differential, high-availability configuration, (total all legs)	0.765
3	52G7350	Terminator, differential, high-availability configuration, 50-pin, high-density (attaches to Y-cable only)	N/A
4	67G1261	Cable, controller-to-7135,	4.5
5	61G8323	Interposer, 68-pin to 50-pin interface	N/A

Notes:

1. When a Y-cable is used, the internal terminator on the controller card must be removed.
2. If item 2 is used (Y-cable), an Item 5 (interposer) is required between item 2 (Y-cable) and item 4 (controller-to-7135 cable).
3. For item 4, other cables can be used as long as the total bus length is kept to 19 meters or less. Refer to "Controller-to-First-Device Cables" on page 4-29 under 7135.

Special Cabling Considerations for the 7135 RAIDiant Array (continued)

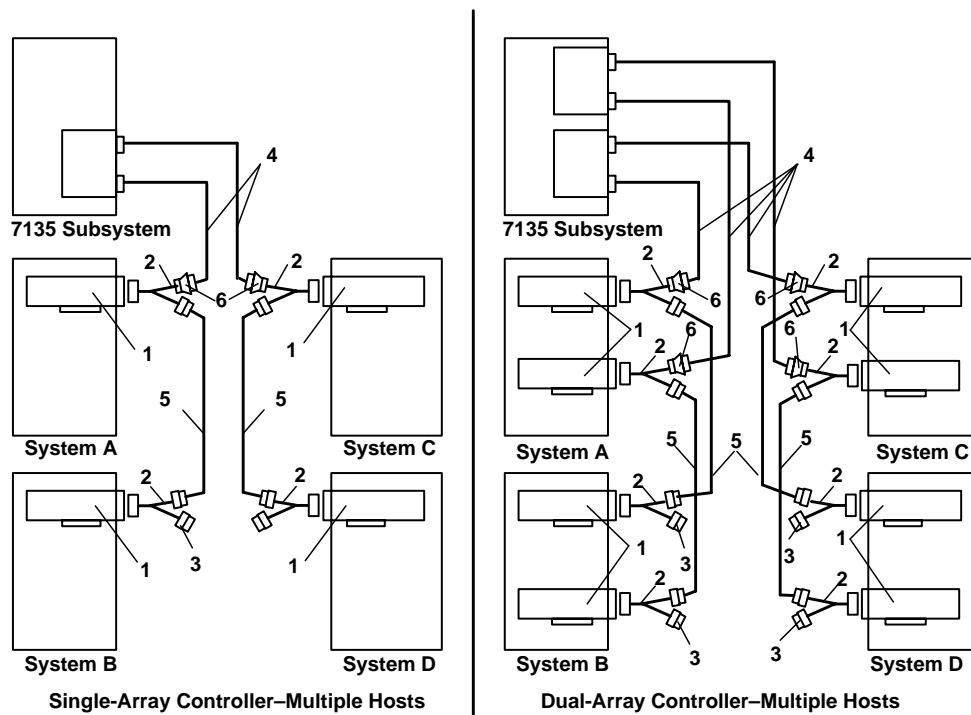

Item Number	Part Number	Description	Cable Length (meters)
1	43G0176 11H2447	SCSI-2 Differential High-Performance External I/O Controller (Type 4-2 labeled 4-2 near the external connector)	N/A
2	52G7348	Y-cable, differential, high-availability configuration, (total all legs)	0.765
3	52G7350	Terminator, differential, high-availability configuration, 50-pin, high-density (attaches to Y-cable only)	N/A
4	67G1261	Cable, controller-to-7135,	4.5
5	52G7349	Cable, system-to-system, SCSI-2 differential	2.5
6	61G8323	Interposer, 68-pin to 50-pin interface	N/A

Notes:

1. When a Y-cable is used, the internal terminator on the controller must be removed.
2. For item 4, other cables can be used as long as the total bus length is kept to 19 meters or less. Refer to table "Controller-to-First-Device Cables" on page 4-29 under 7135.

Cabling the SCSI-2 Single-Ended Fast/Wide Controller FC 2414, 2415, and 9216

To understand the cabling of this controller, read “General SCSI Considerations” on page 4-5, and then read the following for specific information.

There are two unique considerations when cabling this controller:

- The controller card has two independent SCSI controllers. One of the SCSI controllers is used exclusively for internal devices. The other SCSI controller is used exclusively for an external SCSI bus for external devices. Because of this independence, the internal cable length and number of internally attached devices need not be considered when cabling external devices. This is different from previous designs and makes cabling considerations simpler.
- Either bus may be connected as a wide (16-bit) or narrow (8-bit) bus.

Physical differences between the wide (16-bit) bus and the narrow (8-bit) bus are:

Wide Bus (16-bit)	Narrow Bus (8-bit)
Uses a 68 conductor cable.	Uses a 50 conductor cable.
Can attach either all wide (16-bit) or all narrow (8-bit) devices to either bus (narrow devices will only have narrow (8-bit) performance.)	Can only attach to narrow devices.
4 address bits, allowing for 16 unique addresses.	3 address bits, allowing for 8 unique addresses.

Note: AIX 3.2.5 with the appropriate PTFs supports only SCSI IDs from 0 to 7, limiting the number of device attachments to 7 per bus. The default address of this controller is 7.

SCSI-2 Single-Ended Cable Lengths Using This Controller

SCSI-2 single-ended cabling should be accomplished in accordance with the following criteria and machine type specifications.

Note: SCSI-2 single-ended cable length maximums must be carefully observed to avoid transmission line mismatch problems.

Due to increased maximum data rates, the SCSI-2 single-ended bus length is specified to be 3 m (9.9 ft) maximum. This maximum length includes the internal cabling of a device that has two connectors. All configurations incorporating OEM devices are restricted to a 3 m (9.9 ft) maximum length. However, certain configurations using supported devices with specialized termination allow longer bus lengths. The following bulleted items indicate the only supported configurations that are longer than 3 m.

Note: The following referenced part numbers are for cables only; terminators are also required.

- An SCSI bus length of 3.75 m (12.3 ft) may be achieved using part numbers 52G4231 or 92F2559 and 31F4222 or 35F4607 to attach up to 4 external (supported) SCSI devices in a narrow bus implementation to a 7011, 7012, 7013, or 7030 system.
- A maximum SCSI bus length of 5.04 m (16.53 ft) may be achieved using part number 52G4232 or 88G5755 to attach a 9334/500 to a 7011, 7012, 7013, or 7030 system.

- An SCSI bus length of 5.5 m (18 ft) may be achieved using part number 92F2559 to attach a 6226 Drawer containing only new feature code 2555 1GB disk drives (1GB disk drives shipped before 8/17/93 do not work), or feature code 2580 2GB disk drives, or any SCSI-1 drives.
- An SCSI bus length of 5.9 m (19.3 ft) may be achieved using part number 52G4235 to attach a 9334-010 to a 7015 system.

Cable and Terminator Tables for the SCSI-2 Single-Ended Fast/Wide Controllers

The following tables and examples aid in properly cabling a SCSI-2 single-ended bus.

System Internal Cable Lengths

Because this controller card has separate internal and external SCSI buses, the internal cable lengths need not be considered when attaching external SCSI devices.

Optional Internal SCSI-2 Single-Ended Fast/Wide Cables

MT	F/C	Cable Description	Part Number	Cable Length (meters)
Model 5XX and SCSI-2 SE F/W	2430	Internal six-drop cable, 8-bit narrow bus, terminator included	52G7451	1.86
Model 5XX and SCSI-2 SE F/W	2431	Internal six-drop cable, 16-bit wide bus, the terminator is included when the F/C is ordered	52G4430	1.57
7006/7009	2434	Internal three-drop cable, 16-bit wide bus, The terminator is included when the F/C is ordered	65G8085	0.77

Controller-to-First Device Cables

MT	F/C	Cable Description	Part Number	Cable Length (meters)
Host System	2439	Controller-to-first device (where first device has one connector) 8-bit narrow bus, terminator included in MES F/C	52G4231	1.5
Host System	2437	Controller-to-first device (where first device has two connectors) 8-bit narrow bus, terminator included in MES F/C	92F2559	1.5
	2435	Controller-to-first device (where first device has two connectors) 16-bit wide bus, terminator included in MES F/C	52G9501	1.5

MT	F/C	Cable Description	Part Number	Cable Length (meters)
9334	9212	Controller-to-9334-010 (8-bit narrow bus)	52G4235	4.75
9334	2926/9226 2907/9207	Controller-to-9334-500 (8-bit narrow bus)	52G4232 88G5755	1.5 2.38
7027	3133 3134	Controller-to-7027	40H7353 40H7352	3 6

Device Internal Cable Lengths

Refer to "Device Internal Cable Lengths" on page 4-9 for information on narrow bus devices.

Device-to-Device Cables

Refer to "Device-to-Device Cables" on page 4-9 for information on narrow bus cables.

MT	F/C	Cable Description	Part Number	Cable Length (meters)
7204-1xx	2860/9139	Fast/Wide SE device-to-device cable (16-bit)	52G9921	.5

Terminators for Use with This Controller

Card Internal

The controller has an onboard terminator for the internal bus; no additional terminators are needed if this bus is not being used.

Internal Cabling

The internal narrow device cable has a built-in terminator. The wide cable uses a detachable terminator. Part number 88G3977 is used for new build cables and has locking tabs for a more secure connection. The earlier version part number 92F2566 (FRU 92F0322) is still available.

Card External Connector

The controller has an onboard terminator for the external bus; no additional terminators are needed if this bus is not being used.

SCSI-2 Single-Ended External Cabling

An SCSI-2 single-ended external terminator is required when any external cable or device is attached. The terminator should be attached at the external end of the bus.

Terminator Description	Part Number
50 pin, low-density, external, narrow bus, FPT-18+	51G7736
50-pin, low-density, external, narrow bus, FPT18C	52G4260
68 pin, high-density, external wide Boulay	52G9907 (FRU 92F0432)

Note: The 52G4260 terminator is used in place of the 51G7736 terminator; the 51G7736 terminator is still usable.

Cable Examples for the SCSI-2 Single-Ended Fast/Wide Controller

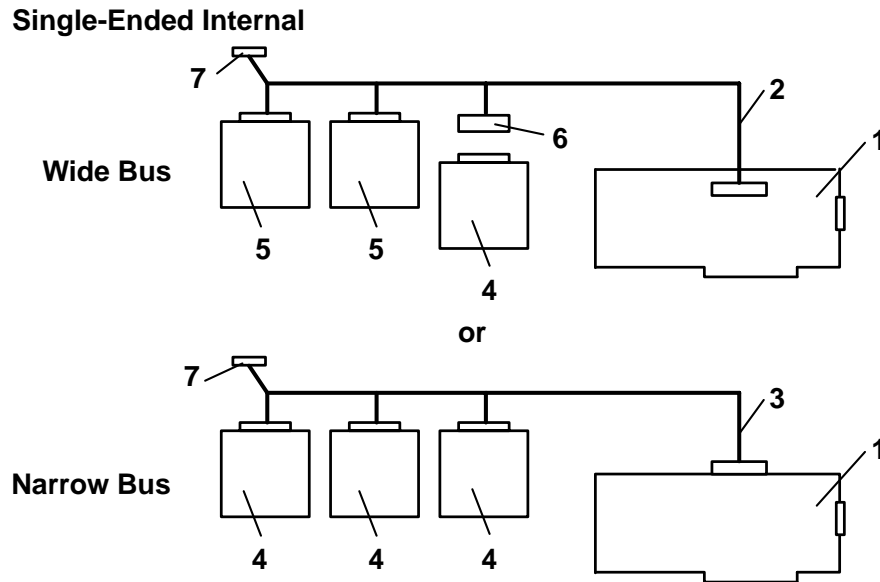

Item Number	Description
1	Controller
2	Internal SCSI cable and terminator assembly (wide)
3	Internal SCSI cable and terminator assembly (narrow)
4	Narrow device (50-pin connector)
5	Wide device (68-pin connector)
6	68-pin to 50-pin interposer (only used with 7012 and 7030 "wide" bus, FRU 92F0324 (assembly P/N 92F2565)) Note: 7013 and 7015 boxes do not allow mixing wide and narrow devices on the same bus.
7	Terminator

Single-Ended External Narrow Bus

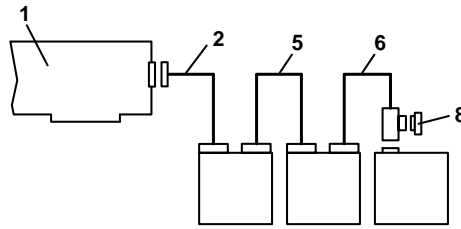

or

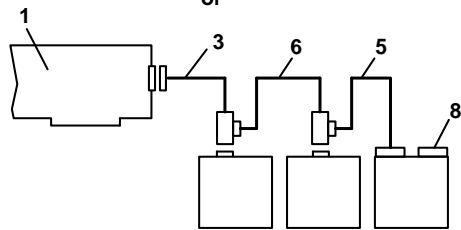

Single-Ended External Wide Bus

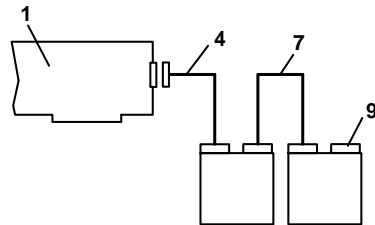

Item Number	Part Number	Description	Cable Length (meters)
1		Controller	N/A
2	92F2559	Controller-to-dual-connector device (narrow 8-bit)	1.5
3	52G4231	Controller-to-single-connector device (narrow 8-bit)	1.5
4	52G9501	Controller-to-dual-connector device (wide 16-bit)	1.5
5	33F4607	Device-to-dual-connector device (narrow 8-bit)	.66
6	31F4222	Device-to-single-connector device (narrow 8-bit)	.7
7	52G9921	Device-to-dual-connector device (wide 16-bit)	.5
8	51G7736 or 52G4260	Terminator (narrow 8-bit)	N/A
9	52G9907	Terminator (wide 16-bit)	N/A

Special Cabling Considerations for the 7131 Single-Ended Interface

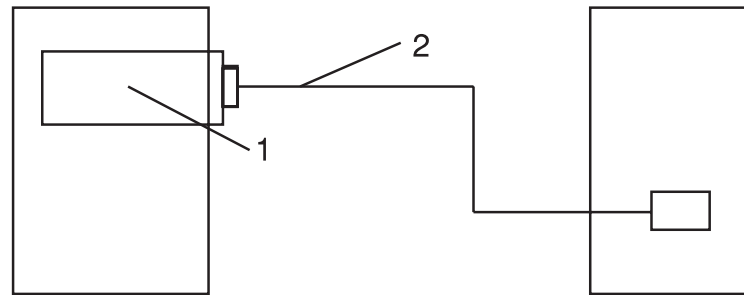

7131 - 105

Item Number	Part Number	Description	Cable Length (meters)
1	11H3600	SCSI-2 Fast/Wide Controller	N/A
2	52G9501	Controller-to-dual-connector device (16-bit)	1.5

Note: The single ended version of the 7131 cannot be connected to any other device. The SCSI terminator is built into the 7131.

Special Cabling Considerations for the 7027 - HSC Single-Ended Interface

The following figure shows the back of the 7027. Banks A, B, and C are on the front of the 7027.

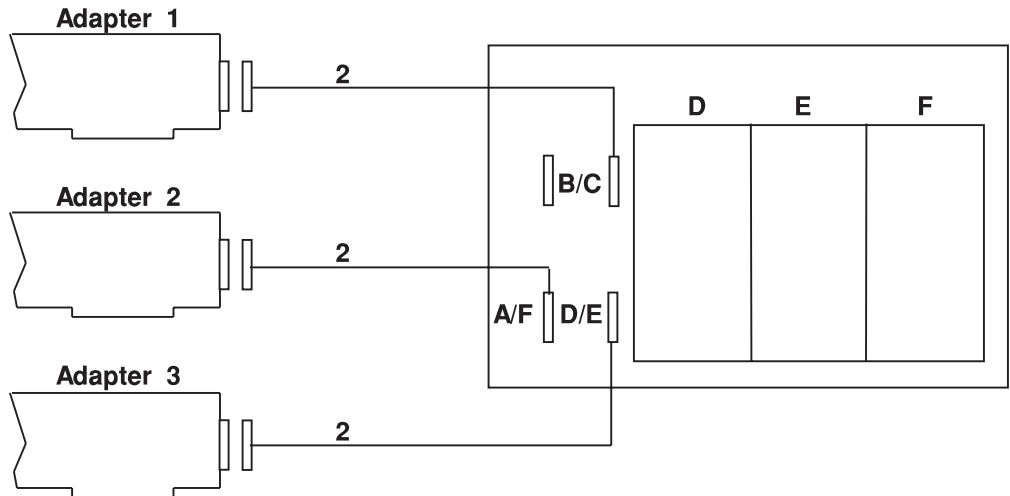

Note: Up to three adapters can be connected as shown. The adapters are on different SCSI-Busses. This is not a multi-initiator setup.

- Adapter 1 controls Banks B and C.
- Adapter 2 controls Banks A and F.
- Adapter 3 controls Banks D and E.

Item Number	Part Number	Description	Cable Length (meters)
1		SCSI-2 Fast/Wide Adapter	NA
2	40H7353	Adapter-to-Dual-Connector device (16-bit)	3.0
	40H7352		6.0

High-Availability SCSI-2 Single-Ended Fast/Wide Controller Cabling

Special Cabling Considerations for the 7027 - HSC Single-Ended Interface with the Twin Initiator Option (FC 6552)

Attention:

- FC 6552 must be installed on your 7027 to use the twin initiator option.
- Be sure that your software application supports the twin (multi) initiator option before attempting to use.
- Only one adapter per system per SCSI bus is allowed.

The following figure shows the back of the 7027. Banks A, B, and C are on the front of the 7027. Banks A and F are not used in the twin (multi) initiator option. Refer to the *7027 Disk Drive Drawer Installation and Service Guide*, order number SA38-0520 for more information.

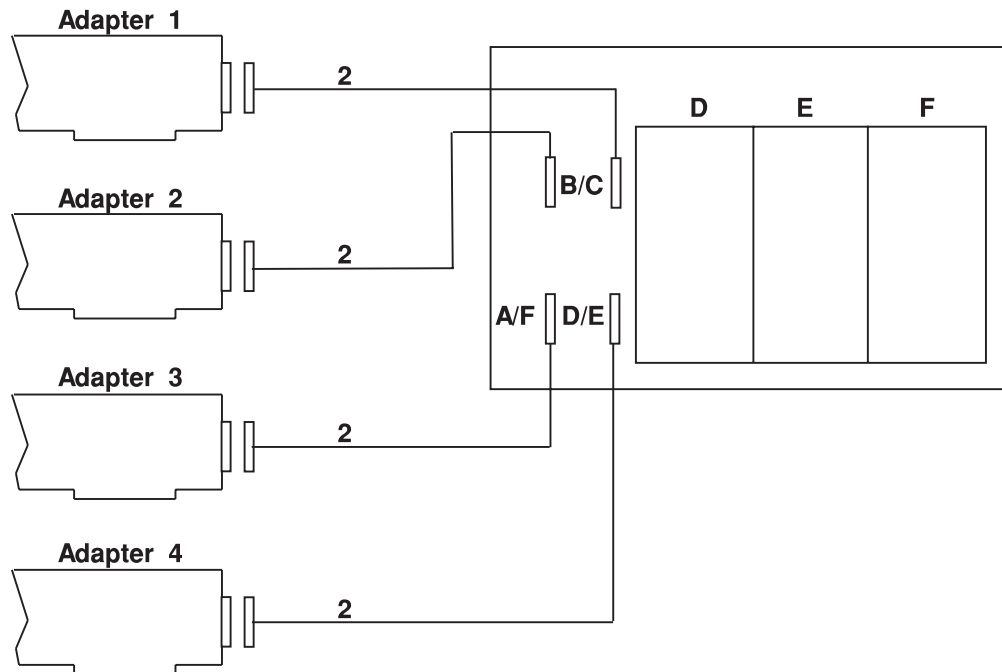

Note:

- The top two connectors control banks B, and C (adapters 1, and 2 share the same SCSI bus). Adapters 1 and 2 must be in different host systems.
- The bottom two connectors control banks D, and E (adapters 3, and 4 share the same SCSI bus). Adapters 3 and 4 must be in different host systems.
- Banks A, and F are not available with this twin initiator configuration.

Item Number	Part Number	Description	Cable Length (meters)
1		SCSI-2 Fast/Wide Adapter	NA
2	40H7353	Adapter-to-Dual-Connector device (16-bit)	3.0
	40H7352		6.0

Cabling the SCSI-2 Differential Fast/Wide Controller FC 2413, 2416, and 9217

To understand the cabling of this controller, read “General SCSI Considerations” on page 4-5, and then read the following for specific information.

This controller has two independent SCSI-2 fast/wide controllers:

- One controller is single-ended. It is used for the internal SCSI bus, supporting single-ended internal connections only. The internal bus can be cabled as either wide (16-bit) or narrow (8-bit). Refer to “Cable Examples for the SCSI-2 Single-Ended Fast/Wide Controller” on page 4-44 for examples of internal bus cabling.
- The other controller is used exclusively for the external SCSI bus and supports differential connections only. The external bus can be cabled as either wide (16-bit) or narrow (8-bit).

Note: AIX 3.2.5 with the appropriate PTFs supports only SCSI IDs from 0 to 7, limiting the number of device attachments to 7 per bus. The default address of this controller is 7.

SCSI-2 Differential Cable Lengths Using This Controller

SCSI-2 differential cabling should be accomplished in accordance with the following criteria and machine-type specifications.

Note: SCSI-2 differential cable length maximums must be carefully observed to avoid transmission line mismatch problems.

The SCSI-2 fast/wide differential bus length is specified to be 25 m (82 ft) maximum. For configurations using external cabling length restrictions, refer to the length from the built-in differential terminator on the controller to the last device on the external SCSI bus.

Attach only differential devices on the external bus and single-ended devices on the internal bus.

Cable and Terminator Tables for the SCSI-2 Differential Fast/Wide Controller

The following tables and examples aid in properly cabling a SCSI-2 differential bus.

Controller-to-First-Device Cables

MT	F/C	Cable Description	Part Number	Cable Length (meters)
Host System	2438	Controller-to-first device (where first device has two connectors) 8-bit narrow bus terminator included in MES F/C	88G3636	1.5
Host System	2436	Controller-to-first device (where first device has two connectors) 16-bit wide bus terminator included in MES F/C	52G4337	1.5
9334	2922/9222 2924/9224	Controller-to-9334-011 (8-bit narrow bus)	52G4327 88G5757	4.75 8.0
9334	2932/9232 2934/9234 2936/9236 2938/9238	Controller-to-9334-501 (8-bit narrow bus)	52G4326 88G5758 88G5759 88G5760	1.5 2.38 4.75 8.0
7134	2902 2905 2912 2914 2918	Controller-to 7134 (16-bit wide bus)	88G5750 88G5749 88G5747 88G5748 88G5746	2.4 4.5 12.0 14.0 18.0
	2920	Interposer required to attach 7134 controller cable to the controller.	50G0460	N/A
7135	2902/9202 2905/9205 2912/9212 2914/9214 2918/9218	Controller-to 7135 (16-bit wide bus) (can also be used as a System-to-System cable with Y-cable 52G4234)	67G1260 67G1261 67G1262 67G1263 67G1264	2.4 4.5 12.0 14.0 18.0
	2920	Interposer required to attach 7135 controller cable to the controller.	50G0460	N/A
7027	3134 3133 3137	Controller-to 7027 (16-bit wide bus) F/C includes necessary interposer	40H7352 40H7353 88G5747	3.0 6.0 12.0
	3138	Controller-to 7137 (16-bit wide bus) F/C includes necessary interposer	88G5746	18.0
	2920	Interposer required to attach 7137 controller cable to the controller.	50G0460	N/A

Differential Device Internal Cable Lengths

Refer to “Differential Device Internal Cable Lengths” on page 4-29 for information on narrow bus differential devices.

Differential Device-to-Device Cables

Refer to “Differential Device-to-Device Cables” on page 4-30 for information on narrow bus differential cables.

Device-to-Device Wide (16-bit)

MT	F/C	Cable Description	Part Number	Cable Length (meters)
Host System	2424	Device-to-device, (16-bit wide bus)	52G4291	.6
	2425		52G4233	2.5
7135	2901/9201	7135-to-7135 (16-bit wide bus)	67G1259	.6

Differential Terminators for Use with This Controller

Card External Connector

The controller has an onboard terminator for the external bus; no additional terminators are needed if this bus is not being used.

SCSI-2 Differential External Cabling

An SCSI-2 differential external terminator is required when any external cable or device is attached. The terminator should be attached at the external end of the bus.

Terminator Description	Part Number
50-pin, low-density, external, narrow bus (8-bit)	79X3795
50-pin, low-density, external, narrow bus (8-bit)	87G1356
50-pin, high-density external narrow bus (8-bit)	52G7350
68-pin, external, wide bus (16-bit)	61G8324

Cabling Examples for the SCSI-2 Differential Fast/Wide Controller

Differential External

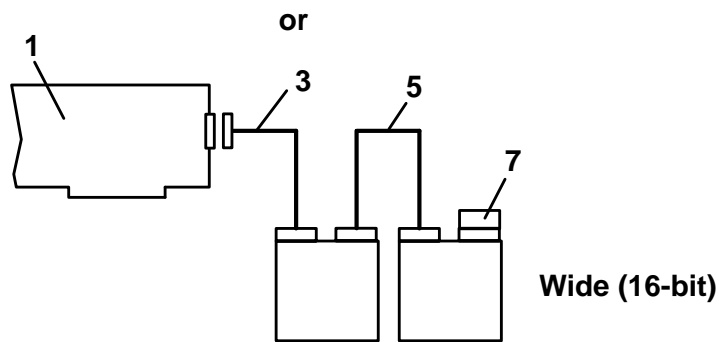
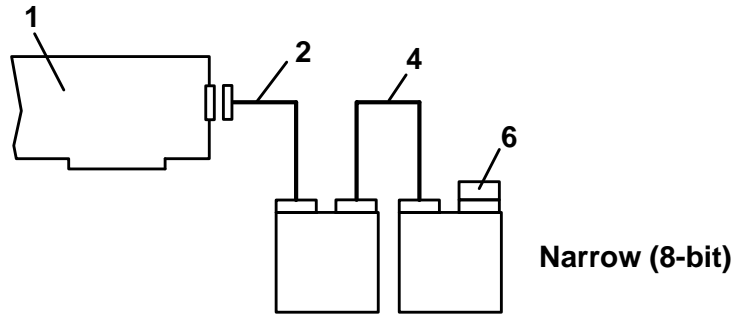

Item Number	Part Number	Description	Cable Length (meters)
1		SCSI-2 Differential Fast/Wide Controller (4-6 or 4-C)	N/A
2	52G4327 52G4326 88G3636	Controller-to-9334-011 (narrow 8-bit) Controller-to-9334-501 (narrow 8-bit) Controller-to-720x (narrow 8-bit)	4.75 1.5 1.5
3	52G4337	Controller-to-first device (wide 16-bit)	1.5
4	95X2492 95X2498 74G8511	Device-to-9334-011 (narrow 8-bit) Device-to-9334-501 (narrow 8-bit) Device-to-720x (narrow 8-bit)	2.0 2.0 .66
5	52G4291 52G4233	Device-to-device (wide 16-bit)	.6 2.5
6	87G1356	Terminator (narrow 8-bit)	N/A
7	61G8324	Terminator (wide 16-bit)	N/A

Special Cabling Considerations for the 7134

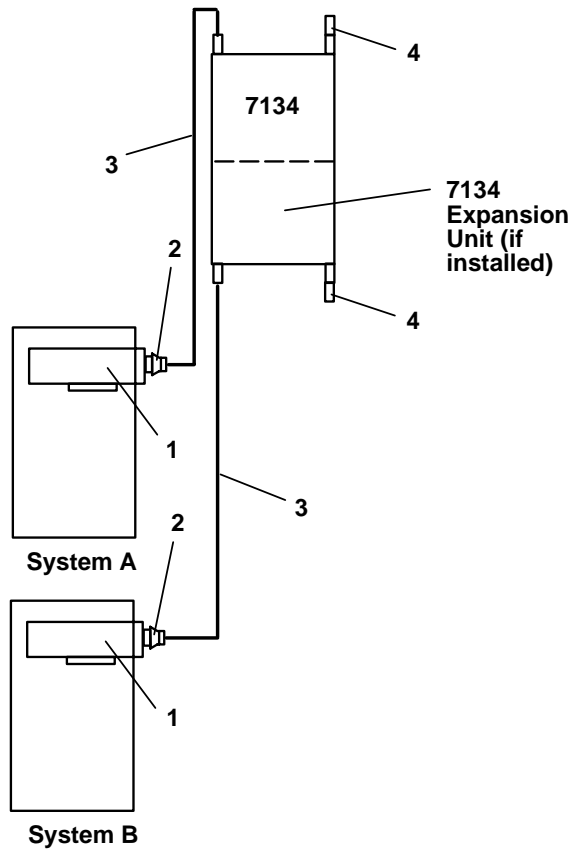

Item Number	Part Number	Description	Cable Length (meters)
1		SCSI-2 Differential Fast/Wide Controller (4-6 or 4-C)	N/A
2	50G0460	Interposer (converts controller connector to "P" type)	N/A
3	88G5750	Controller-to-7134 cable (wide)	2.4
	88G5749	Controller-to-7134 cable (wide)	4.5
	88G5747	Controller-to-7134 cable (wide)	12.0
	88G5748	Controller-to-7134 cable (wide)	14.0
	88G5746	Controller-to-7134 cable (wide)	18.0
4	61G8324	Terminator (wide 16-bit)	N/A

Note: System A and B are not on the same SCSI bus and do not share any drives.

Special Cabling Considerations for the 7134 (Continued)

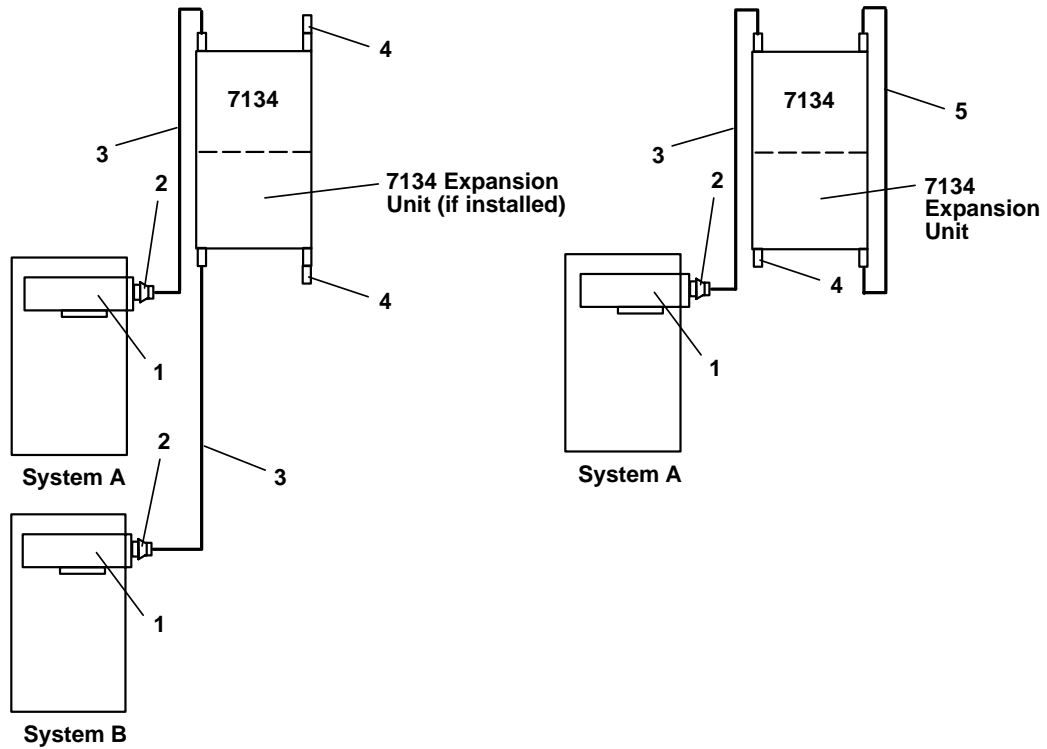

Item Number	Part Number	Description	Cable Length (meters)
1		SCSI-2 Differential Fast/Wide Controller (4-6 or 4-C)	N/A
2	50G0460	Interposer (converts controller connector to "P" type)	N/A
3	88G5750	Controller-to-7134 cable (wide)	2.4
	88G5749	Controller-to-7134 cable (wide)	4.5
	88G5747	Controller-to-7134 cable (wide)	12.0
	88G5748	Controller-to-7134 cable (wide)	14.0
	88G5746	Controller-to-7134 cable (wide)	18.0
4	61G8324	Terminator (wide 16-bit)	N/A
5	67G3341	Internal SCSI-2 Bus Linkage Cable (wide)	0.69

Notes:

- For item 3, various cable combinations can be used as long as the total bus length is kept to 25 meters or less. Total bus length must include the internal cable length for the 7134 which is 2.7 m. The bus length for the 7134 Expansion Unit is an additional 2.7 m.
- Systems A and B are not on the same SCSI-2 bus and do not share disk drives.

Special Cabling Considerations for the 7135 RAIDiant Array

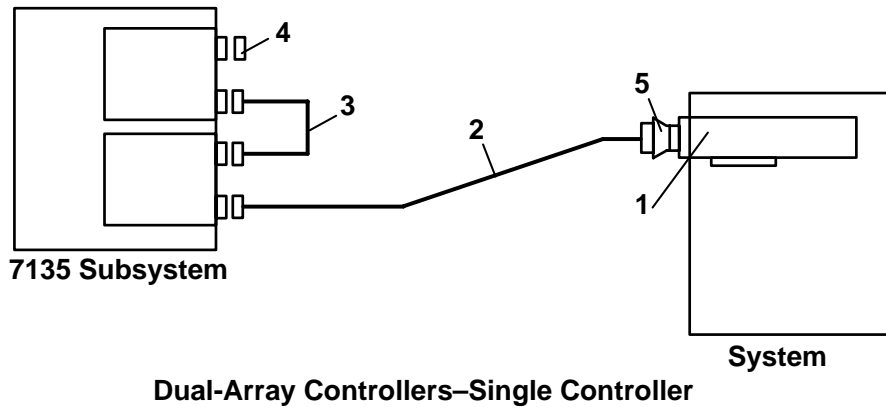

Item Number	Part Number	Description	Cable Length (meters)
1		SCSI-2 Differential Fast/Wide Controller (4-6 or 4-C)	N/A
2	67G1264	Cable, controller-to-7135	18
3	67G1259	Cable, array-controller-to-array-controller	0.6
4	61G8324	Terminator (wide 16-bit)	N/A
5	50G0460	Interposer (wide 16-bit) (converts the controllers external connector to "P" type)	N/A

Note: For item 2, a shorter cable can be used. Refer to "Controller-to-First-Device Cables" on page 4-50 under 7135.

Special Cabling Considerations for the 7331-205 or 7331-305 8mm Tape Library or the 7336-205 4mm Tape Library

Single Drive - Single Host or Dual Drive - Single Host

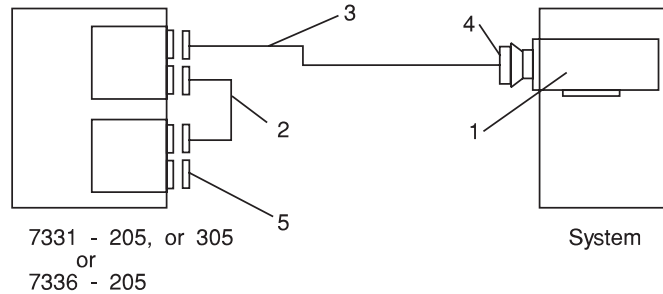

Dual Drive - Dual Host

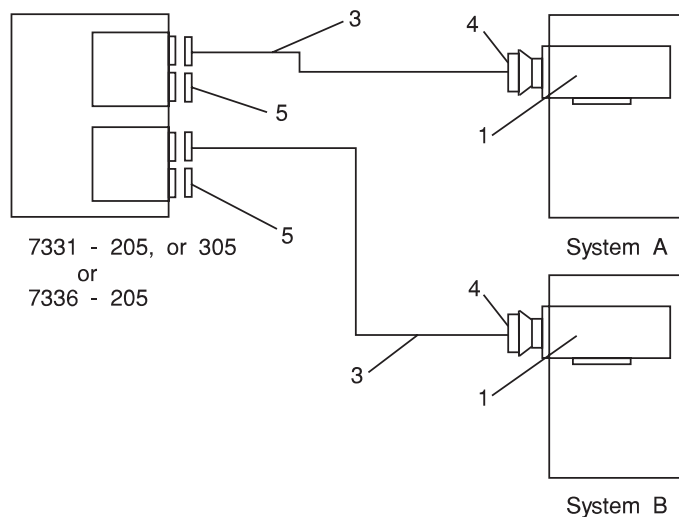

Item Number	Part Number	Description	Cable Length (meters)
1		SCSI-2 Differential Fast/Wide Controller (4-6 or 4-C)	
2		Cable - SCSI jumper	
3	06H0636 52G4233 88G5749 88G5747 88G5746	Device-to-Device cable (wide 16-bit)	1.0 2.5 4.5 12.0 18.0
4	50G0460	Interposer (wide 16-bit) converts the controller's external connector to a "P" type connector.	
5	61G8324	Terminator (16-bit)	

Note: For more information on these configurations, refer to the *7331 Tape Library Installation Guide*, order number SA26-7110, or the *7336 4mm Tape Library Model 205 Set up and Operator guide*, order number SA37-0309.

Special Cabling Considerations for the 7131 Differential Interface (FC 2508)

Single Host - Single Tower

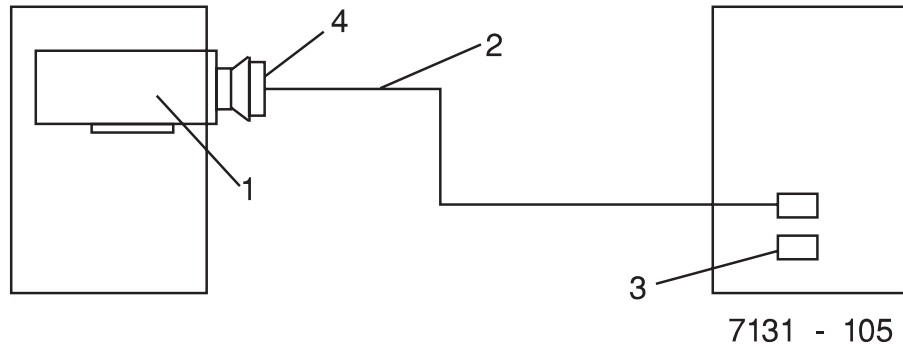

Single Host - Dual Tower

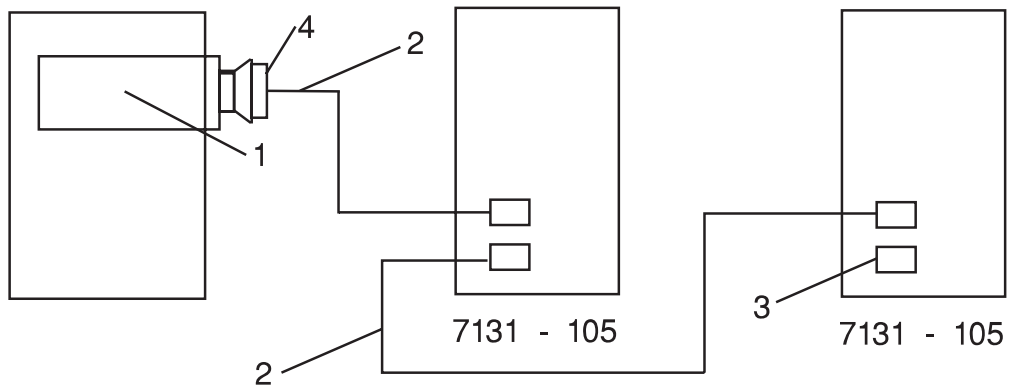

Item Number	Part Number	Description	Cable Length (meters)
1		SCSI-2 Differential Fast/Wide Controller (4-6 or 4-C)	
2	52G4291 06H0636 52G4233 88G5749 88G5747 88G5748 88G5746	Device-to-Device cable (wide 16-bit)	0.6 1.0 2.5 4.5 12.0 14.0 18.0
3	61G8324	Terminator (16-bit)	
4	50G0460	Interposer (wide 16-bit) converts the controller's external connector to a "P" type connector.	

Special Cabling Considerations for the 7027 - HSD Differential Interface

The following figure shows the back of the 7027. Banks A, B, and C are on the front of the 7027.

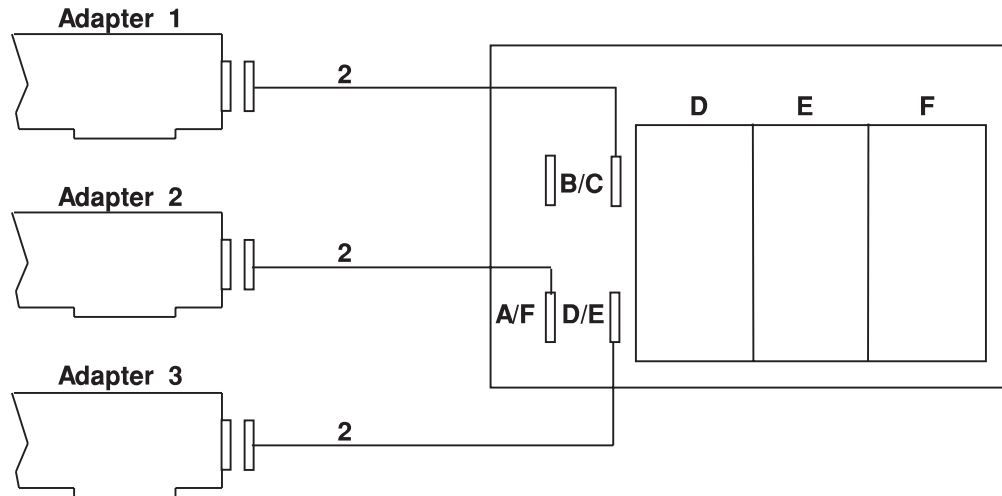

Note: Up to three adapters can be connected as shown. The adapters are on different SCSI-Busses. This is not a multi-initiator setup.

- Adapter 1 controls Banks B and C.
- Adapter 2 controls Banks A and F.
- Adapter 3 controls Banks D and E.

Item Number	Part Number	Description	Cable Length (meters)
1		SCSI-2 Differential Fast/Wide Controller (4-6 or 4-C)	NA
2	52G4233 40H7351 88G5747 88G5746	Adapter-to-Dual-Connector device (16-bit)	2.5 6.0 12.0 18.0

High-Availability Configuration SCSI-2 Differential Fast/Wide Controller Cabling

Attention: The following section describes supported hardware configurations. These configurations may not be supported by your software application. Be sure that your software application supports these configurations before attempting to use.

The high-availability configuration is implemented with the SCSI-2 Fast/Wide controller by removing the three built-in differential terminator resistors (labelled RN1, RN2, and RN3) on the controller, then attaching the middle leg connector of the high-availability configuration Y-cable to the controller's external 68-pin connector. The remaining two legs of the Y-cable are then used to attach other systems and devices to the SCSI bus.

If the SCSI-2 Fast/Wide Controller is at the end of the SCSI bus, the shorter leg of the high-availability configuration Y-cable must be terminated with the appropriate terminator.

Note: The high-availability configuration (Y-cable with a terminator on the shorter top leg) allows disconnection of the controller from a "live" SCSI bus, by removal of the external bus connection (the middle leg of the Y-cable). Although termination and SCSI bus continuity is maintained during removal of the controller, noise generated may create undetected bus errors if the bus is in use during the time of removal. To maintain data integrity, the SCSI bus should be inactive during the removal of controllers, devices, cables, or terminators.

High-availability software must be installed on system units cabled into a high-availability configuration.

Cable and Terminator Tables for the High-Availability Configuration SCSI-2 Differential Fast/Wide Controller

The following tables and examples aid in properly cabling an SCSI-2 differential bus.

MT	F/C	Cable Description	Part Number	Cable Length (meters)
7204-3xx	2845/9131 2846/9132	Device-to-Device cable, wide bus (16-bit)	52G4291 52G4233	0.66 2.5
Host System	2426	Controller-to-device Y-cable, wide bus (16-bit)	52G4234	0.94
Host System	2427	Controller-to-device Y-cable, narrow bus (8-bit)	52G4349	0.765
7204-2xx	2854/9138 2921/9221	From Y-cable-to-7204-2xx, narrow bus (8-bit)	87G1358 67G0593	.6 4.75
9334	2921/9221 2923/9223	From Y-cable-to-9334-11, narrow bus (8-bit)	67G0593 95X2494	4.75 8.0
9334	2935 2937	From Y-cable-to-9334-501, narrow bus (8-bit)	67G0566 67G0562	4.75 8.0
Host System	2425	System-System cable (target mode environment) (16-bit)	52G4233	2.5
Host System	2423	System-System cable (target mode environment) (8-bit)	52G7349	2.5

Terminator Description	Part Number
50-Pin, high-density, external, Y-cable, narrow bus (8-bit)	52G7350
68-Pin, external, wide bus (16-bit)	61G8324

Cabling Examples for the High-Availability Configuration SCSI-2 Differential Fast/Wide Controller

High-Availability Wide (16-bit)

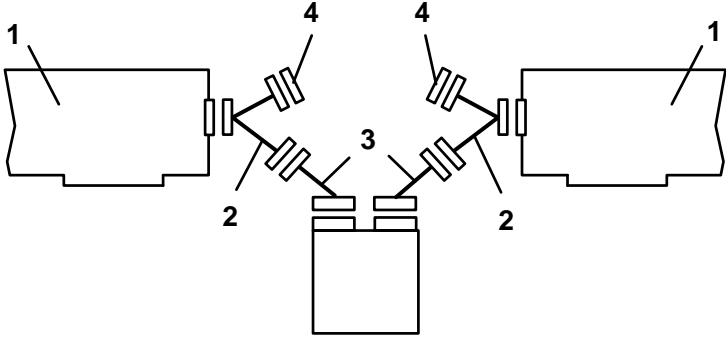

Attention: Adapters must be in different host systems; only one adapter per system per SCSI bus is allowed.

Item Number	Part Number	Description	Cable Length (meters)
1		SCSI-2 Differential Fast/Wide Controller (4-6 or 4-C)	N/A
2	52G4234	Y-cable	.94
3	52G4291 52G4233	Device-to-Device cable (Y-cable to device for high availability use)	0.6 2.5
4	61G8324	Differential Terminator (wide 16-bit)	N/A

Note: When a Y-cable is used, the three (3) termination resistors on the controller card must be removed.

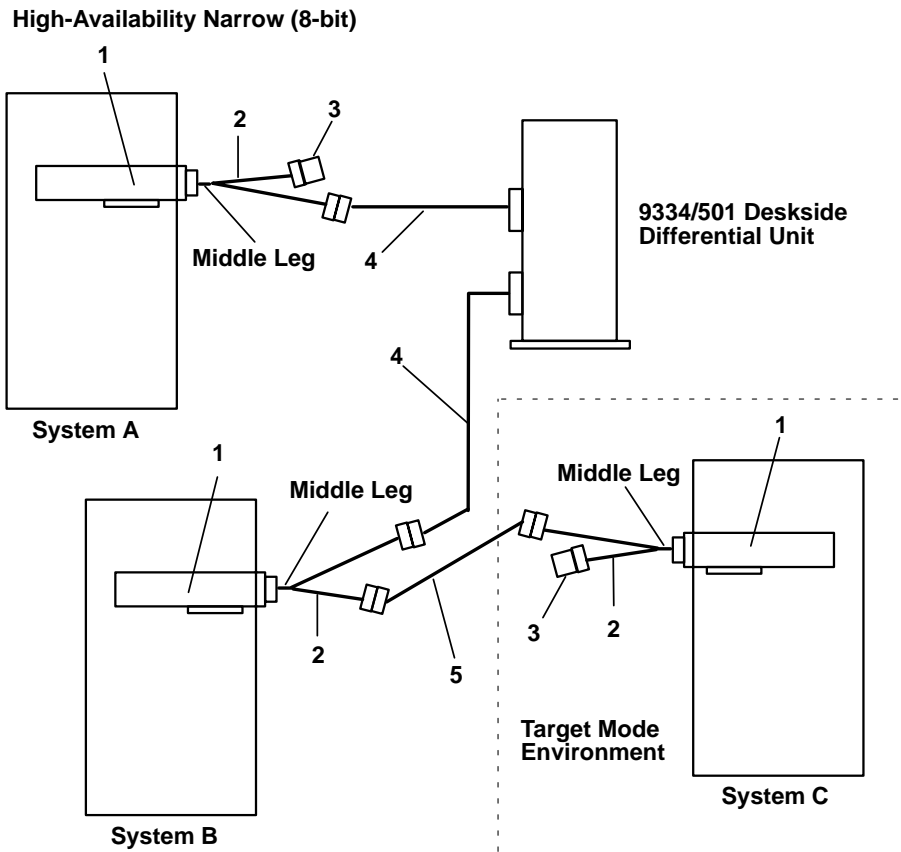

Item Number	Part Number	Description	Cable Length (meters)
1		SCSI-2 Differential Fast/Wide Controller (4-6 or 4-C)	N/A
2	52G4349	System 8-bit differential Y-cable, (total all legs)	0.765
3	52G7350	Differential terminator, high-availability configuration, 50-pin, high-density (attaches to Y-cable only)	N/A
4	67G0566	Cable, controller-to-first 9334-501 deskside differential unit,	4.75
5	52G7349	Cable, system-to-system, SCSI-2 differential	2.5

Notes:

1. When a Y-cable is used, the three (3) termination resistors on the controller card must be removed.
2. For item 4, other cable combinations can be used as long as the total bus length is kept to 25 meters or less. Refer to table "Controller-to-First-Device Cables" on page 4-50 under 9334/501.

High-Availability Narrow (8-bit)

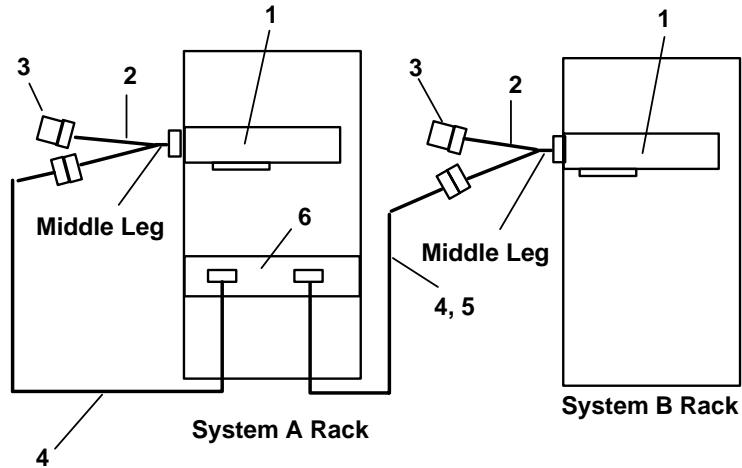

Item Number	Part Number	Description	Cable Length (meters)
1		SCSI-2 Differential Fast/Wide Controller (4-6 or 4-C)	N/A
2	52G4349	System 8-bit differential Y-cable, (total all legs)	0.765
3	52G7350	Differential terminator, high-availability configuration, 50-pin, high-density (attaches to Y-cable only)	N/A
4	67G0593	From Y-cable-to-9334, narrow bus (8-bit)	4.75
5	95X2494	From Y-cable-to-9334, narrow bus (8-bit)	8.0
6		9334-011 differential drawer	N/A

Note: When a Y-cable is used, the three (3) termination resistors on the controller card must be removed.

Special Cabling Considerations for the 7027 - HSD Differential Interface with Multiple Initiators

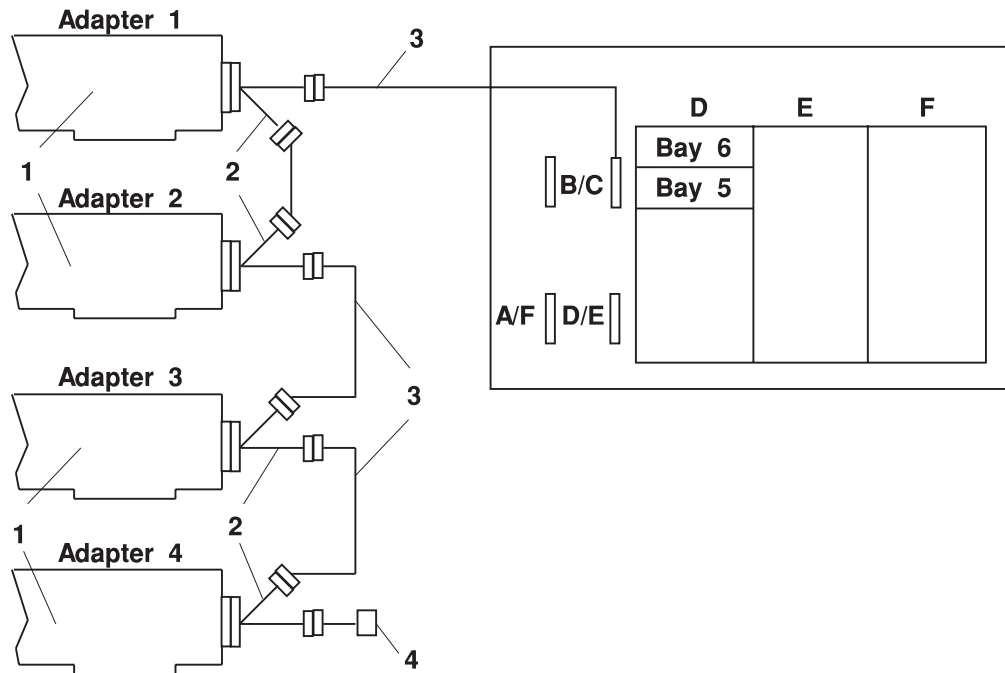

Attention: Adapters must be in different host systems; only one adapter per system per SCSI bus is allowed.

Item Number	Part Number	Description	Cable Length (meters)
1		SCSI-2 Differential Fast/Wide Controller (4-6 or 4-C)	NA
2	52G4234	Y-cable	0.94
3	52G4291 52G4233 88G5749 40H7351	Device-to-Device Cable (wide 16-bit)	0.6 2.5 6.0 12.0
4	61G8324	Terminator (16-bit)	

Note: This configuration shows four adapters in a multiple-initiator configuration with the devices in banks B and C. If four adapters are used then you must remove the devices from bays 5 and 6 in banks D and B. If only three adapters are used, you must remove the device in bay six of banks B and D. For more information, refer to the 7027 Disk Drive Drawer *Installation and Service Guide*, order number SA38-0520.

Note: When Y-cables are used, on card terminating resistors must be removed from the adapters.

Special Cabling Considerations for the High-Availability 7134

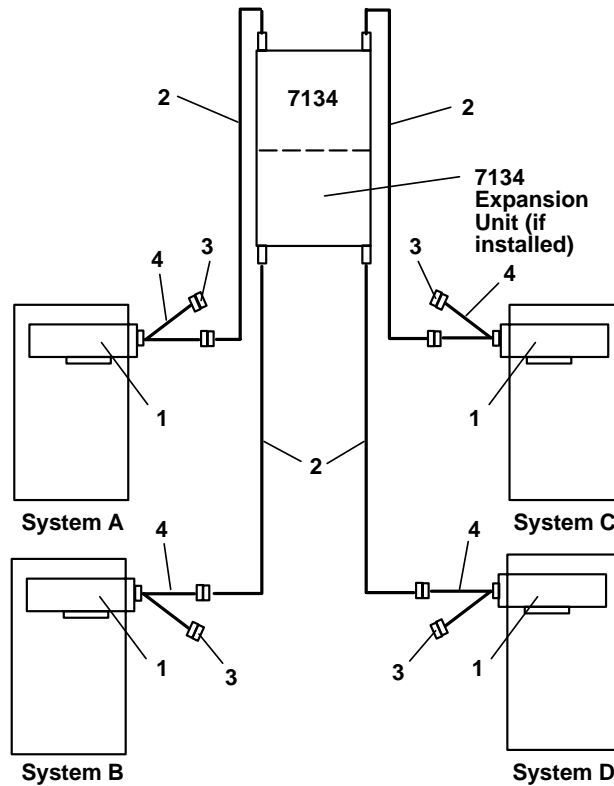

Item Number	Part Number	Description	Cable Length (meters)
1		SCSI-2 Differential Fast/Wide Controller (4-6 or 4-C)	N/A
2	88G5750 88G5749	Controller-to-7134 cable (wide) Controller-to-7134 cable (wide)	2.4 4.5
3	61G8324	Terminator (wide 16-bit)	N/A
4	52G4234	Y-cable	0.94

Notes:

1. When a Y-cable is used, the three (3) termination resistors on the controller card must be removed.
2. For item 2, other cable combinations can be used as long as the total bus length is kept to 25 meters or less. Refer to table "Controller-to-First-Device Cables" on page 4-50 under 7134. Total bus length must include the internal cable length for the 7134. Refer to "Differential Device Internal Cable Lengths" on page 4-29.
3. In this example, systems A and C are on one SCSI bus and systems B and D are on another SCSI bus. In this configuration, systems A and C do not share drives with systems B and D.

Special Cabling Considerations for the High-Availability 7134 (Continued)

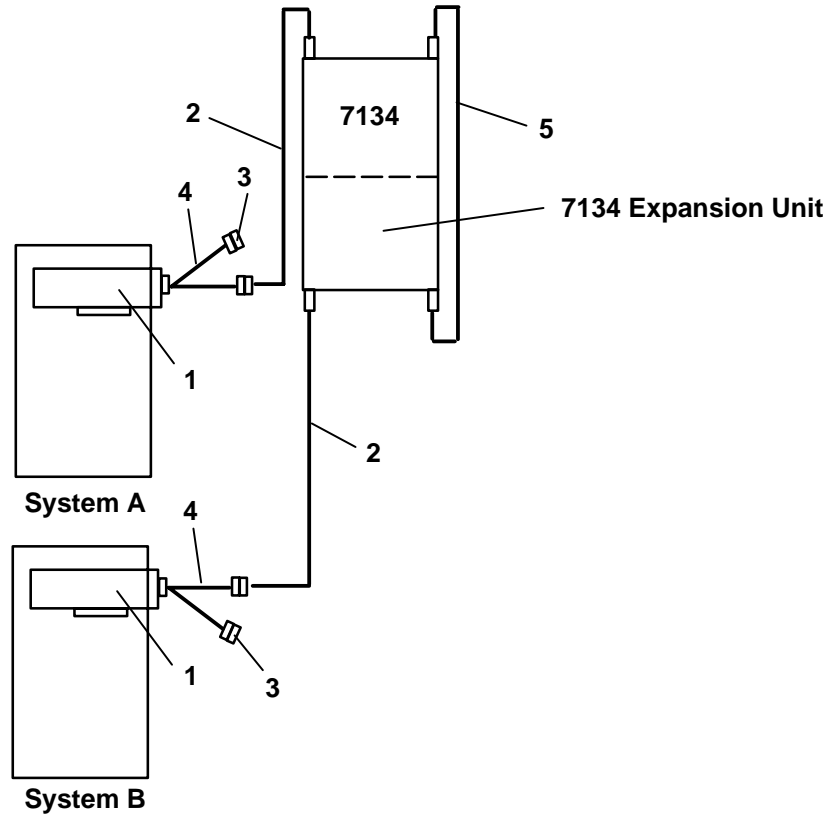

Item Number	Part Number	Description	Cable Length (meters)
1		SCSI-2 Differential Fast/Wide Controller (4-6 or 4-C)	N/A
2	88G5750 88G5749 88G5747 88G5748	Controller-to-7134 cable (wide) Controller-to-7134 cable (wide) Controller-to-7134 cable (wide) Controller-to-7134 cable (wide)	2.4 4.5 12.0 14.0
3	61G8324	Terminator (wide 16-bit)	N/A
4	52G4234	Y-cable	0.94
5	67G3341	Internal SCSI-2 Bus Linkage Cable (wide)	0.69

Notes:

1. For item 2, various cable combinations can be used as long as the total bus length is kept to 25 meters or less. Total bus length must include the internal cable length for the 7134 which is 2.7 m. The bus length for the 7134 Expansion Unit is an additional 2.7 m. For example, if item 2 above is the 4.5 meter cable in both places, the total bus length is .94 m + 4.5 m + 2.7 m + .69 m + 2.7 m + 4.5 m + .94 m which equals 16.97 m
2. When a Y-cable is used, the three (3) termination resistors on the controller card must be removed.

Special Cabling Considerations for the 7135 RAIDiant Array

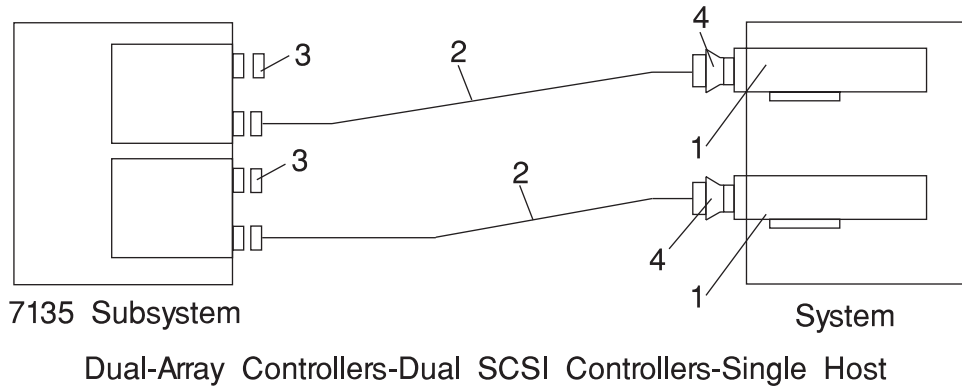

Item Number	Part Number	Description	Cable Length (meters)
1		SCSI-2 Differential Fast/Wide Controller (4-6 or 4-C)	N/A
2	67G1264	Cable, controller-to-7135	18
3	61G8324	Terminator (wide 16-bit)	N/A
4	50G0460	Interposer (wide 16-bit)	N/A

Note: For item 2, a shorter cable can be used. Refer to table “Controller-to-First-Device Cables” on page 4-50 under 7135.

Special Cabling Considerations for the 7135 RAIDiant Array (continued)

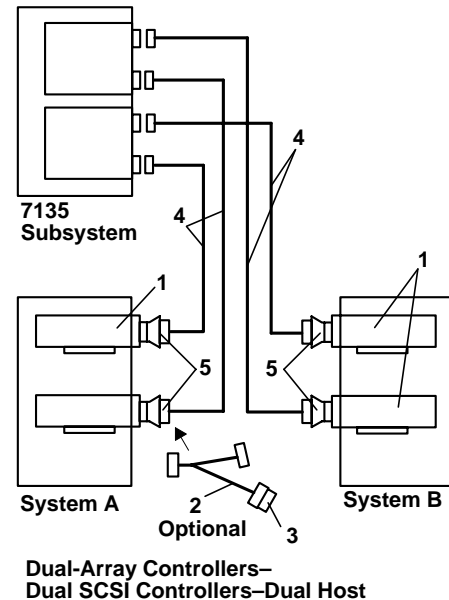
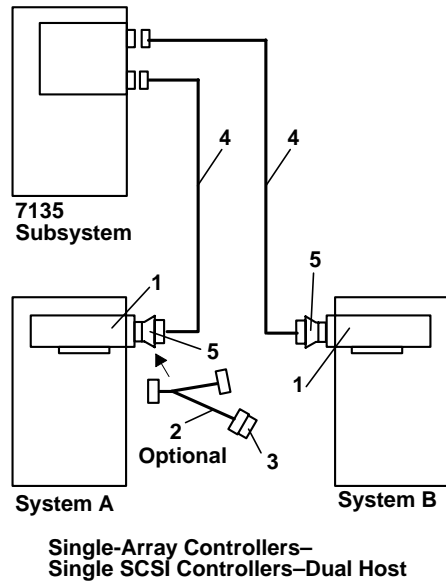

Item Number	Part Number	Description	Cable Length (meters)
1		SCSI-2 Differential Fast/Wide Controller (4-6 or 4-C)	N/A
2	52G4234	Y-cable, differential, high-availability configuration, (total all legs)	0.94
3	61G8324	Terminator (wide 16-bit)	N/A
4	67G1261	Cable, controller-to-7135	4.5
5	50G0460	Interposer (wide 16-bit)	N/A

Notes:

1. When a Y-cable is used, the three (3) termination resistors on the controller card must be removed.
2. If item 2 (Y-cable) is used, item 5 (interposer) is not needed.
3. For item 4, other cable combinations can be used as long as the total bus length is kept to 25 meters or less. Refer to table "Controller-to-First-Device Cables" on page 4-50 under 7135.

Special Cabling Considerations for the 7135 RAIDiant Array (continued)

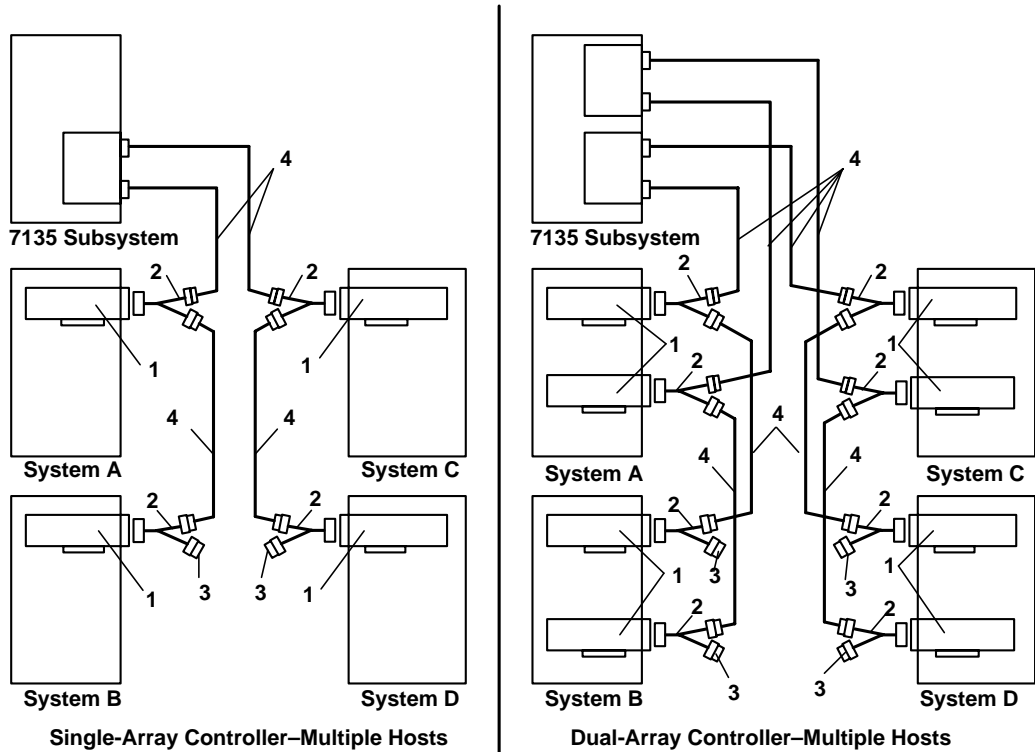

Item Number	Part Number	Description	Cable Length (meters)
1		SCSI-2 Differential Fast/Wide Controller (4-6 or 4-C)	N/A
2	52G4234	Y-cable, differential, high-availability configuration, (total all legs)	0.94
3	61G8324	Terminator (wide 16-bit)	N/A
4	67G1261	Cable, controller-to-7135	4.5
	or 52G4233	Cable, system-to-system, SCSI-2 differential	2.5

Notes:

1. When a Y-cable is used, the three (3) termination resistors on the controller card must be removed.
2. For item 4, other cable combinations can be used as long as the total bus length is kept to 25 meters or less. Refer to table "Controller-to-First-Device Cables" on page 4-50 under 7135.

Special Cabling Considerations for the 7131 Differential Interface (FC 2508) High Availability

Dual Host - Single Tower

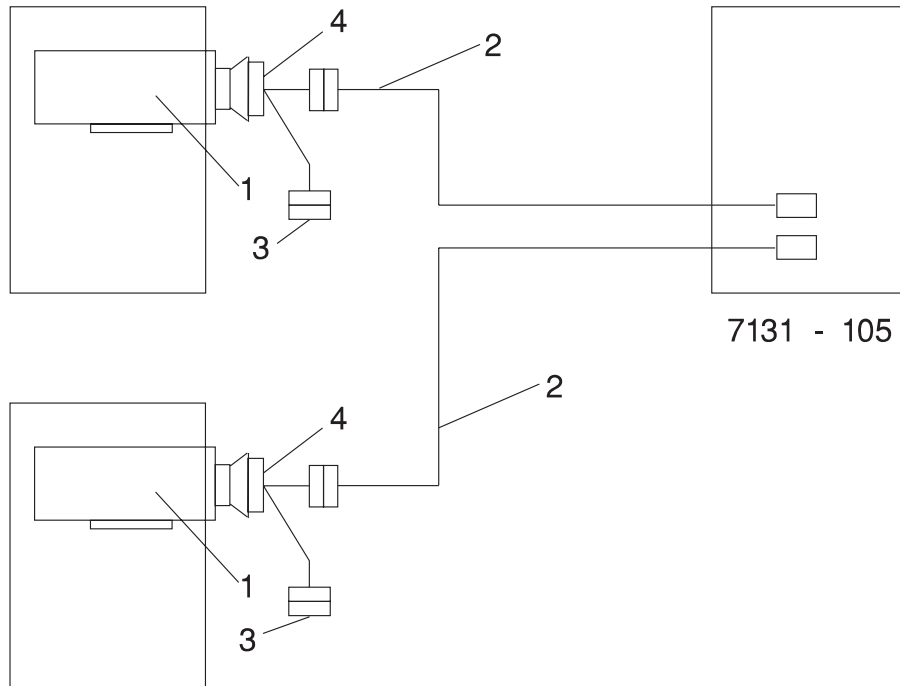

Item Number	Part Number	Description	Cable Length (meters)
1		SCSI-2 Differential Fast/Wide Controller (4-6 or 4-C)	N/A
2	52G4291 06H0636 52G4233 88G5749 88G5747 88G5748 88G5746	Device-to-Device cable (wide 16-bit)	0.6 1.0 2.5 4.5 12.0 14.0 18.0
3	61G8324	Terminator (16-bit)	N/A
4	52G4234	Y-cable	0.94

Note:

1. When a Y-cable is used, the three (3) termination resistors on the controller adapter must be removed.
2. For item 2, any cable combination may be used as long as the total bus length is kept to 25 meters or less.
3. Please refer to the 7131 documentation for SCSI addressing limitations. If there are any devices in the upper media bay of the 7131, the adapters are restricted to certain SCSI IDs.

Chapter 5. Cable Assembly and Pin-Outs

Disclaimer

The information presented in this chapter *does not* guarantee functionality or compliance with any RFI or EMI regulations.

This information should be used along with other information about the location and use of the cables to help provide custom cabling that is acceptable for this customer.

General Cable Building Information

The following information are things to consider and to keep in mind if you are going to build your own cables. All of this information does not apply to all cables you are building. Use the information that is needed.

- Any communications cable being run outdoors must have an appropriate lightning arrester on it.
- All outer foil shields should be connected to the metal shell of the connector at both ends.
- Be sure any wire that is connected at one end is terminated at the other end. No wire should be attached to circuitry at only one end, because it acts like an antenna to pick up or give out electrical noise.
- On *modem* cables for async communications, ground wires for twisted pairs should be connected together and to position 7 of the connector at each end of the cable.
- On *other than modem* async communications cables, the outer foil drain wire should connect to the metal shell of the connector on the system end of the cable. The outer foil drain wire should be connected to position 1 of the connector on the device end of the cable.
- The connectors on all cables should provide strain relief to prevent breaking the wires.

Adapter-Specific Cable Building Information

The following information is presented to help the person building or servicing custom cables understand specific needs of certain adapters.

The following charts show pin-out information for many cables. Only pins that are used are mentioned. Cables are presented alphabetically, according to the letter designations given in Chapter 3, "Cables and Cabling" on page 3-1. The connector summary at the end of this section lists many cables and their associated connectors.

Custom cables must conform to the appropriate standards. Standards information can usually be obtained from a cable vendor, but copies of EIA specifications can be purchased by writing to the following address:

Electronic Industries Association
Attn. Standards Office
2001 Pennsylvania Ave., NW
Washington, DC 20006

Cable Description and Page Number

Most of the cables in this chapter are arranged alphabetically.

Cable	Description	Page
A	PC Parallel Printer Cable	5-3
B and C	Serial Port Jumper Cables	5-5
D	Async Cable EIA-232/V.24	5-6
E	Printer/Terminal Interposer	5-7
I	Printer/Terminal Interface Cable	5-8
J	8-Port Interface Cable	5-8
K	Terminal Cable EIA-422A	5-9
L	16-Port Interface Cable EIA-232	5-9
M	16-Port Interface Cable EIA-422A	5-9
P	8-pin RJ-45 to DB-25 Converter Cable	5-10
Q	X.25 Attachment Cable X.21	5-11
R	X.25 Attachment Cable V.24	5-12
S	X.25 Attachment Cable V.35	5-13
T	4-Port Multiprotocol Communications Interface Cable	5-13
U	V.35 cable for use with 4-Port Multiprotocol Communications Controller	5-14
V	EIA-232D/V.24 cable for use with 4-Port Multiprotocol Communications Controller	5-15
W	X.21 cable for use with 4-Port Multiprotocol Communications Controller	5-16
X	EIA-422A cable for use with 4-Port Multiprotocol Communications Interface Cable (Port 0 only)	5-17
Z	8-pin RJ-45 to DB-9 converter cable for use with the Auto Token Ring LAN Streamer	5-18
AR	Serial Port Cable (EIA-232) for systems with a nine (9) pin serial port connector	5-19
AS	Serial Port Fanout Cable or "Y" Cable (EIA-232) for systems with a single 25 pin connector that has both serial port 1 and serial port 2 on the same connector	5-20
KK	Optical Channel Converter Cable	5-21
N	64-Port Async Controller to 16-Port Async Concentrator Cable	5-22
XX	16-Port Concentrator EIA-232 Printer or Terminal Cable	5-24
YY	16-Port Concentrator EIA-232 Modem Cable	5-26
NB and NC	128-Port Async Controller Cable, 8-wire	5-29
ND	128-Port Async Controller to Remote Async Node Cable	5-31
NE	128-Port Async Controller EIA-232 Modem Cable, System Side	5-32
NF	128-Port Async Controller EIA-232 Modem Cable, Device Side	5-34
NG	128-Port Async Controller EIA-422 Modem Cable, System Side	5-35
NH	128-Port Async Controller EIA-422 modem Cable, Device Side	5-36
NK	10-pin RJ-45 to DB-25 Converter Cable for Use with the Remote Async Node	5-37
NL	Cable for Connecting Remote Async Node to a Printer or Terminal Device	5-38
NM	Cable for Connecting Remote Async Node to a Modem Device	5-40
NP	RS-422 Cable for 16-port RAN	5-43
RA	Serial Re_IPL Cable 25-pin D to 9-pin D	5-44
RB	Serial Re_IPL Cable 25-pin D to 25-pin D	5-45
T1	4 or 8 Port EIA-232 or EIA-422 Multiport/2 Interface Cables	5-46
T2	6-Port Multiport/2 Cable	5-49
T3	6-Port V.35 Portmaster Cable	5-50
T4	8-Port EIA-232 or EIA-422 Portmaster Cable	5-51
T5	6-Port X.21 Portmaster Cable	5-52
T6	6-Port V.35 Network Attachment Cable for use with the 6-Port V.35 Portmaster Adapter/A	5-54
T7	6-Port X.21 Network Attachment Cable for use with the 6-Port X.21 Portmaster Adapter/A	5-55

Cable A

Description: PC Parallel printer Cable.

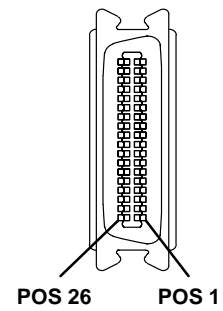
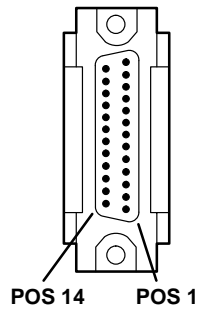

System End Connector	Signal	Device End Connector
Pin (Male)		Socket (Female)
1	Strobe	1
2	Data	2
3	Data	3
4	Data	4
5	Data	5
6	Data	6
7	Data	7
8	Data	8
9	Data	9
10	ACK	10
11	Busy	11
12	PE	12
13	Select	13

System End Connector	Signal	Device End Connector
Pin (Male)		Socket (Female)
14	Autofeed XT	14
18	Ground	15
19	Ground	16
Not Used		17
Not Used		18
21	Ground	19
21	Ground	20
21	Ground	21
22	Ground	22
22	Ground	23
23	Ground	24
23	Ground	25
24	Ground	26
24	Ground	27
24	Ground	28
25	Ground	29
25	Ground	30
16	INIT	31
15	Error	32
25	Ground	33
Not Used		34
Not Used		35
17	Select IN	36

Cables B and C

Description: Serial Port Jumper Cables.

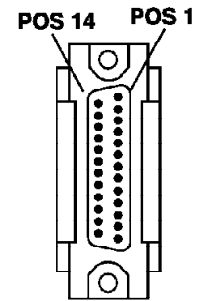
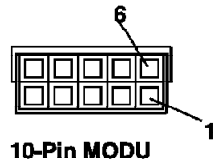

System End Connector	Signal	Device End Connector
Socket (Female)		Pin (Male)
1	TxD	2
2	DTR	20
3	RTS	4
4	RI	22
5	Not Used	
6	RxD	3
7	DSR	6
8	CTS	5
9	CD	8
10	Signal Ground Shield	7 1

Cable D

Description: Async Cable EIA-232/V.24.



System End Connector	Signal	Device End Connector
Socket (Female)		Pin (Male)
Shell	Shield Ground	1, Shell
2	TxD	2
3	RxD	3
4	RTS	4
5	CTS	5
6	DSR	6
7	Signal Ground	7
8	CD	8
20	DTR	20
22	RI	22

For applications where the Multiprotocol Adapter/A is used, the following additional pins are required.

System End Connector	Signal	Device End Connector
Socket (Female)		Pin (Male)
15	Tx CLK	15
17	Rx CLK	17

Cable E

Description: Printer/Terminal Interposer-EIA-232. Use this to convert a modem cable to Printer or terminal connection.

This is a Printer/Terminal interposer which is about two inches long and connects the pins from input to output as shown below. See cable I on page 5-8 for a printer terminal cable.



System End Connector	Signal	Device End Connector
Socket (Female)		Pin (Male)
1	Shield Ground	shell
2	TxD	3
3	RxD	2
4	RTS	5
5	CTS	4
6, 8	DSR, CD	20
7	Signal Ground	7
20	DTR	6, 8

Cable I

Description: Printer/Terminal Interface Cable. The cable is 3m or 10 feet long.



System End Connector	Signal	Device End Connector
Socket (Female)		Pin (Male)
Shell	Shield Ground	Shell, 1
2	TxD	3
3	RxD	2
4	RTS	5
5	CTS	4
6, 8	DSR, CD	20
7	Signal Ground	7
20	DTR	6, 8

Cable J

Description: Part of the Multiport Interface Cable.

The pin-out information for the connector on the back of the 8-port adapter is given in the adapters chapter of this book on page 1-73. The Multiport Interface Cable allows attachment of up to eight separate devices to any of the 8-port asynchronous adapters.

Cable K

Description: Terminal Cable EIA-422A.



System End Connector	Signal	Device End Connector
Socket (Female)		Pin (Male)
shell	Shield Ground	1
2	TxA	15
3	RxA	19
4	TxB	17
5	RxB	25
7	Signal Ground	7

Cable L

Description: Part of the 16-Port Interface Cable-EIA-232.

The pin-out information for the connector on the back of the 16-Port Async Adapter-EIA-232 is given in the adapter section on page 1-77.

Cable M

Description: Part of the 16-Port Interface Cable-EIA-422A.

The pin-out information for the connector on the back of the 16-Port on page 1-79. Async Adapter EIA-422 is given in the adapter section.

Cable P

Description: RJ-45 to DB-25 Converter for the 16-Port Concentrator

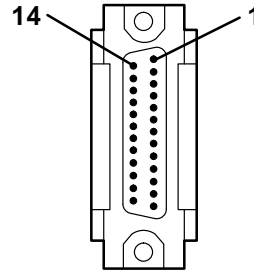
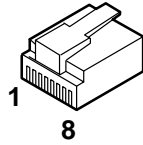

Concentrator End Connector	Signal	Device End Connector
Pin		Pin (Male)
1	Shield Ground	Float *
2	RTS	4
3	RxD	3
4	CD	8
5	Signal Ground	7
6	TxD	2
7	DTR	20
8	CTS	5

Cable Q

Description: X.25 Attachment Cable X.21.

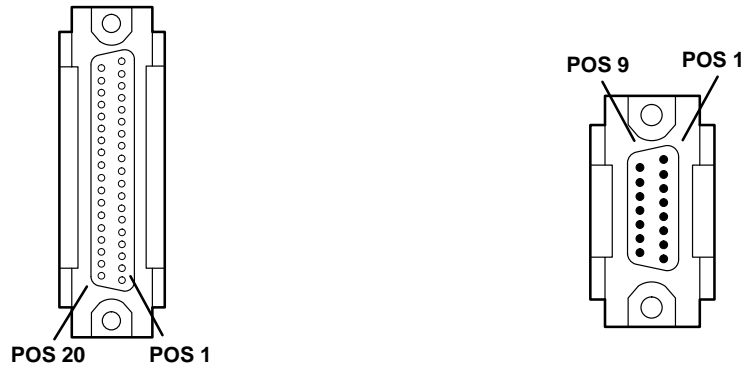

System End Connector	Signal	Device End Connector
Socket (Female)		Pin (Male)
10	T (A)	2
28	T (B)	9
11	C (A)	3
29	C (B)	10
12	R (A)	4
30	R (B)	11
13	I (A)	5
31	I (B)	12
14	S (A)	6
32	S (B)	13
7*	Ground	8
9*	Ground	8

*Tied together at system end connector.

Cable R

Description: X.25 Attachment Cable-V.24.



System End Connector	Signal	Device End Connector
Socket (Female)		Pin (Male)
2	TxD	2
3	RxD	3
4	RTS	4
5	CTS	5
6	DSR	6
8	CD	8
24	Tx CLK	15
26	Rx CLK	17
27	LLBT	18
20	DTR	20
21	RLBT	21
22	CI	22
25	TI	25
7*	Ground	7
9*	Ground	7
15*	Ground	7

*Tied together at system end connector.

Cable S

Description: X.25 Attachment Cable V.35.

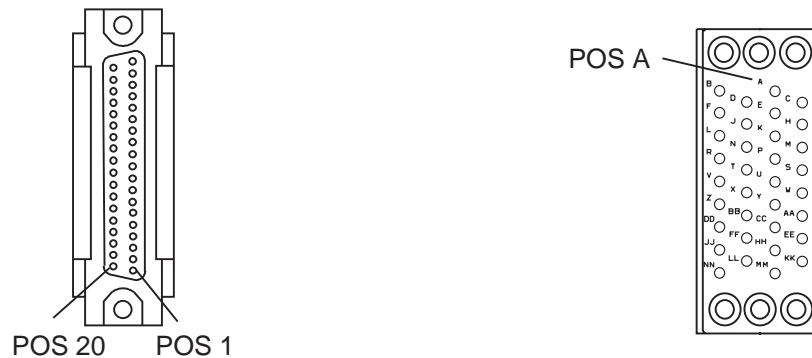

System End Connector	Signal	Device End Connector
Socket (Female)		Pin (Male)
4	RTS	C
5	CTS	D
6	DSR	E
8	CD	F
20	DTR	H
22	CI	J
35	TxD (A)	P
17	TxD (B)	S
37	RxD (A)	R
19	RxD (B)	T
36	Tx Clk (A)	Y
18	Tx Clk (B)	AA
34	Rx Clk (A)	V
16	Rx Clk (B)	X
7	Ground	B
15	Ground	B

Cable T

Description: This cable comes with an Interface/Breakout box. It has eight connectors for the four ports. See cabling chapter of this book for description of the 4-Port Multiprotocol Communications interface cable. The interface cable is used with the 4-Port Multiprotocol Communications Controller.

The pin-out information for the connector on the back of the 4-Port Multiprotocol Communications Controller is given in the adapters chapter on page 1-42.

Cable U

Description: 4-Port Multiprotocol Communications Controller V.35 Cable.

Use a 15-position female connector and a 34-position block connector. The bulk cable must have four shielded twisted pairs and six individually shielded wires.



System End Connector Socket (Female)	Signal	Twisted Pair Number	Device End Connector Pin (Male)
1	Ground Shield		A (Shield)
2	TxD (B)	1	S
3	RTS		C
4	RxD (B)	2	T
5	CTS		D
6	DSR		E
7	CD		F
8	Signal Ground		B
9	TxD (A)	1	P
10	Tx Clk (A)	3	Y
11	RxD (A)	2	R
12	Tx Clk (B)	3	AA
13	Rx Clk (B)	4	X
14	Rx Clk (A)	4	V
15	DTR		H

Cable V

Description: EIA-232D/V.24 cable for use with the 4-Port Multiprotocol Communications Controller.

Use a 25-position male connector and a 25-position female connector. Use bulk cable that has individually shielded wires.

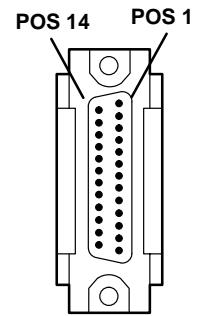
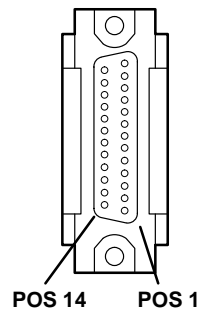

System End Connector	Signal	Device End Connector
Socket (Female)		Pin (Male)
2	TxD	2
3	RxD	3
4	RTS	4
5	CTS	5
6	DSR	6
7	Signal Ground	7
8	CD	8
15	Tx Clk	15
17	Rx Clk	17
20	DTR	20
22	RI	22
23	HRS	23
24	DTE Clk	24
1	Shield Ground	

Cable W

Description: X.21 cable for use with the 4-Port Multiprotocol Communications Controller.

Use a 15-position male connector and a 15-position female connector. Use bulk cable with at least five shielded twisted pairs. Wire the pairs as shown (the pin numbers are the same on both ends).

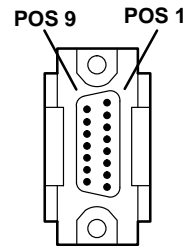
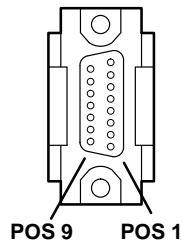

System End Connector	Signal	Device End Connector
Socket (Female)		Socket (Female)
	Shield	
2	T(A)	2
3	C(A)	3
4	R(A)	4
5	I(A)	5
6	S(A)	6
8	Signal Ground	8
9	T(B)	9
10	C(B)	10
11	R(B)	11
12	I(B)	12
13	S(B)	13

Cable X

Description: EIA-422A cable for use with the 4-Port Multiprotocol Communications Controller (Port 0 only).

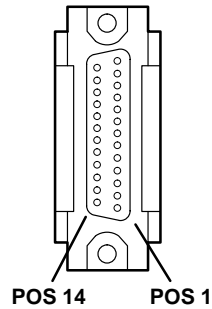

System End Connector	Signal	Device End Connector
Socket (Female)		Customer-supplied
	Ground Shield	
2	TxA	-
3	RxA	-
4	TxB	-
5	RxB	
7	Signal Ground	-
17	RxB Clk	-
22	RxA Clk	-
23	TxA Clk	-
24	TxB Clk	-

Cable Z

Description: 8-pin RJ-45 to DB-9 converter cable for use with the Auto Token Ring LAN Streamer.

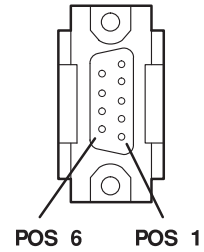
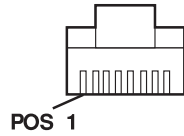

8-Pin RJ-45 Connector		9-Pin D-Shell Connector	
Pin	Signal	Signal	Pin
1	No Connection		
2	No Connection		
3	Ring Out A	Ring Out 2	5
4	Ring In B	Ring In 1	1
5	Ring In A	Ring In 2	6
6	Ring Out B	Ring Out 1	9
7	No Connection		
8	No Connection		

Cable AR

Description: This Serial Port cable (Async Cable EIA-232) is for systems that have a nine pin serial port connector.



System End Connector Socket (Female)	Signal	Device End Connector Pin (Male)
Shell	Shield Ground	1, Shell
3	TxD	2
2	RxD	3
7	RTS	4
8	CTS	5
6	DSR	6
5	Signal Ground	7
1	CD	8
4	DTR	20
9	RI	22

Cable AS

Description: This Serial Port fanout cable (Async Cable EIA-232D) is a feature that makes the second Serial Port available on systems that have a single serial port connector with signals for two serial ports. The pin-out is such that if a standard serial port cable is installed on the system then Serial Port (1) is available. This Serial Port fanout cable is a "Y" cable with three connectors. They have a single standard serial port connector that connects to the system and two standard serial port output connectors, one for serial port (1) and another for serial Port (2).



System End Connector	Signal	Device End Connector
Socket (Female)		Pin (Male)
Shell	Shield Ground	1, Shell
2	TxD (1)	2
3	RxD (1)	3
4	RTS (1)	4
5	CTS (1)	5
6	DSR (1)	6
7	Signal Ground	7
8	CD (1)	8
20	DTR (1)	20
22	RI (1)	22
Shell	Shield Ground	1, Shell
14	TxD (2)	2
16	RxD (2)	3
19	RTS (2)	4
13	CTS (2)	5
15	DSR (2)	6
7	Signal Ground	7
12	CD (2)	8
24	DTR (2)	20
17	RI (2)	22
Others	Reserved	Others

Cable KK

Description: Optical Channel Converter Cable.

If customer-supplied, the cable must be built based on the following:

- Operating wavelength: 780 nm
- Fiber type and length:
 - 50/125 um (minimum length, 4 m (13 ft)), maximum length is determined by user-available link loss.
 - 62.5/125 um (minimum length, 4 m (13 ft)), maximum length is determined by user-available link loss, and cannot exceed 500 m (1640 ft), regardless of link loss.
- User-available link loss: 10.5 dB
- Averaged launched power: Minimum -4.7 dBm, Typical -3 dBm, Maximum -0.9 dBm
- Receiver sensitivity: Minimum -16.0 dBm, Maximum -0.9 dBm
- SC connector attenuation: Typical 0.25 dB, Maximum 0.5 dB
- Total fiber bandwidth must exceed 300 MHz.

64-Port Async Controller to Async Concentrator Cable

The following information is for custom built cables connecting the 64-Port Async Controller to the 16-Port Concentrator.

Both ends use the RJ-45 connectors. The cable has six conductors (three twisted pair) and is shielded on the outside.

Cable N

Description: 64-Port Async Controller to 16-Port Async Concentrator Cable

Line Length

If built to a length of 305 m (1000 feet) or less, each conductor must be 28 AWG or larger (typically stranded wire with seven strands of number 36 wire); if built between 305 m (1000 feet) and 762 m (2500 feet), each conductor must be 24 AWG or larger solid wire. Use appropriate RJ-45 connector for wire type.

The removable toroid(s) (some may have only one) is supplied on the 7.6 m (25 foot) cable shipped with the adapter. It must be removed from the cable supplied with the adapter and installed on the custom built cable. Install one of them within 152 mm (6 inches) of the 16-port concentrator and the other one (if available) within 152 mm (6 inches) of the adapter.

Use the following information to build this cable.

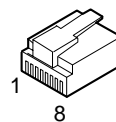
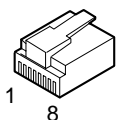

Concentrator End Connector Position	Wiring of the Pairs	Mnemonic (Signal Name)	64-Port Async Controller End Connector Position
1	Pair 1	Transmit data A	1
2	Pair 1	Transmit data B	2
3	Shield	No connection	3
4	Pair 2	Transmit Clock B	4
5	Pair 2	Transmit Clock A	5
6	No connection	Shield	6
7	Pair 3	Receive Data B	7
8	Pair 3	Receive Data A	8

Attention: The receivers and drivers used in most asynchronous communications devices are sensitive to electrostatic discharge (ESD). To reduce the possibility of exposure to ESD, observe the following cabling practices when building or using device cables for attachment to the Remote Async Node 16-Port EIA-232:

Note: Do not build a cable that has exposed conductors, leads, or pins that could be touched by someone not protected against ESD. Avoid the use of punchdown blocks and patch panels which have exposed terminator/pins. In the event that you use intermediate connectors or cables, be sure to discharge them to ground before plugging them into equipment.

16-Port Concentrator-to-Device Cables

Cable XX

Description: 16-Port Concentrator EIA-232 Printer or Terminal Cable

The following information is for custom built cables connecting the 16-Port Concentrator to a printer or terminal device.

This cable can be up to 61 m (200 ft) long. Use overall foil/braid shielded multi-conductor cable that is recommended for low capacitance (less than 12.5 picofarads per foot) use. Conductors should be 28 AWG (7 strands of Number 36 wire). For lengths of less than 61 m (200 ft), a higher capacitance cable can be used, as long as the total capacitance does not exceed 2500 picofarads.

Note: Connections to pins 6 and 22 are not required since DSR and RI are not supported on this controller. If DSR and RI wires are included in the cable, ensure that they are not connected to socket pins, as they may act as noise-receiving antennas and could impair data transmission.

Attention: The receivers and drivers used in the 16-Port Concentrator are very sensitive to electrostatic discharge (ESD). To reduce the possibility of exposure to ESD, observe the following cabling practices th

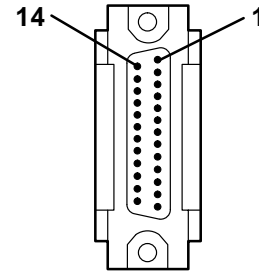
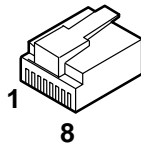

Concentrator End Connector	Signal	Device End Connector
Pin		Pin (Male)
1	Shield Ground	Float *
2	RTS	5
3	RxD	2
4	CD	20
5	Signal Ground	7
6	TxD	3
7	DTR	6, 8
8	CTS	4

Note: *In some cases it may be preferable to connect the shield ground at Pin 1 of the device end and allow the system end to float. In either case, the shield should be connected to the frame ground at one end only.

Cable YY

Description: 16-Port Concentrator EIA-232 modem Cable

The following information is for custom built cables connecting the 16-port concentrator to a modem.

This cable can be up to 61 m (200 ft) long. Use overall foil/braid shielded multi-conductor cable that is recommended for low capacitance (less than 12.5 picofarads per foot) use. Conductors should be 28 AWG (7 strands of Number 36 wire). For lengths of less than 61 m (200 ft), a higher capacitance cable can be used, as long as the total capacitance does not exceed 2500 picofarads.

Note: Connections to pins 6 and 22 are not required since DSR and RI are not supported on this controller. If DSR and RI wires are included in the cable, ensure that they are not connected to socket pins, as they may act as noise-receiving antennas and could impair data transmission.

Attention: The receivers and drivers used in the 16-Port Concentrator are very sensitive to electrostatic discharge (ESD). To reduce the possibility of exposure to ESD, observe the following cabling practices when building or using device cables for attachment to the 16-Port Concentrator:

1. Do not build a cable that has exposed conductors, leads, or pins that could be touched by someone not protected against ESD. Avoid the use of punchdown blocks and patch panels. In the event that you use intermediate connectors or cables, be sure to discharge them to ground before plugging them into equipment.
2. Do not run any cables outdoors without having proper transient voltage suppression devices installed.
3. Do not route cables near or around items such as power transformers, high-power switching devices and refrigerations units.
4. Use shielded cables. All wires should be terminated, not floating. The shield should be connected to shield ground at the concentrator.

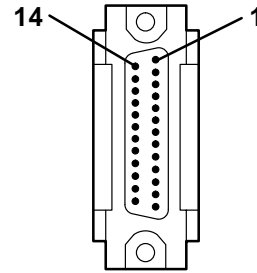
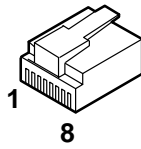

Concentrator End Connector	Signal	Device End Connector
Pin		Pin (Male)
1	Shield Ground	Float *
2	RTS	4
3	RxD	3
4	CD	8
5	Signal Ground	7
6	TxD	2
7	DTR	20
8	CTS	5

Note: *In some cases it may be preferable to connect the shield ground at Pin 1 of the device end and allow the system end to float. In either case, the shield should be connected to the frame ground at one end only.

128-Port Async Controller

The following information is for custom built cables connecting the 128-Port Async Controller to the Remote Async Nodes (RANs) and RANs to async devices. For more information on asynchronous communications, see *AIX Versions 3.2 and 4 Asynchronous Communications Guide* order number SC23-2488.

128-port async adapter

FC (8128) 128-Port Async Adapter is a Micro Channel adapter which can communicate with a Remote Async Node (RAN) at bit rates up to 1.2 Mbps.

Cabling the adapter and the four different Remote Async Nodes

The following table shows the bit rates when the different remote async nodes are connected:

Adapter Feature Code	Adapter Description	Remote Async Node	Maximum RAN to device Bit Rate in bps
8128	Micro Channel 128-Port Async	FC 8130 box style EIA-232	57,000
		FC 8136 rack style EIA-232	
		FC 8137 box style Enhanced EIA-232	230,000
		FC 8138 box style Enhanced RS-422	

128-Port Async Controller to Remote Async Node Cables

The cable has an HD-15 male connector on the controller side and an HD-15 female connector on the remote async node side.

Cables NB and NC

Description: 128-Port Async Controller Cable, 8-wire.

The cable has eight conductors, four twisted-pair, and is shielded on the outside. If built to a length of 300 m (1000 ft) or less, conductors should be 28 AWG (stranded wire) with a capacitance rating of 52 pF/m (16 pF/ft) or less (Belden type 9806 or equivalent). For lengths greater than 300 m (1000 ft), conductors should be 24 AWG (stranded wire) with a capacitance rating of 52 pF/m (16 pF/ft) or less (Belden type 9831 or equivalent).

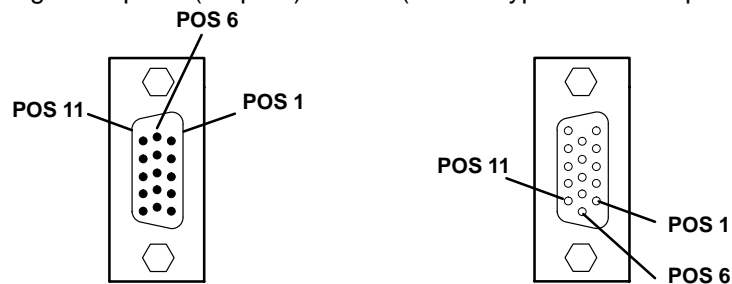

System End Connector		Device End Connector	
Pin (Male)	Signal	Signal	Socket (Female)
1	RxD -	TxD -	1
2	RxD +	TxD +	2
4	RxC -	TxC -	4
5	RxC +	TxC +	5
6	TxD -	RxD -	6
7	TxD +	RxD +	7
9	TxC -	RxC -	9
10	TxC +	RxC +	10
Shell	Shield Ground	Shield Ground	Shell

Line Length, 8-wire

Controller line length for the 128-port async subsystem is measured as the total cabling length from the adapter to the last remote async node on the controller line. Individual cable lengths between remote async nodes or between the adapter and the first remote async node are not significant as long as total cable length does not exceed 1200 m (3930 feet) depending on the baud rate.

The 128-port async controller supports multiple controller line baud rates in 8-wire direct-attach mode. The following table shows the maximum allowable controller line length for each supported baud rate. The controller line length is the actual cable length from the controller to the last remote async node in the controller line.

For maximum performance, NB cables can be greater than 4.6 m (15 ft) if the distance from the controller to the last remote async node in the controller line does not exceed 300 m (1000 ft) running at 1.2 Mbps or 90m (300 ft.) running at 2.4 Mbps.

Controller Line Baud Rate	Total Controller Cable Length	
	m	ft
bps		
2400	1200	3930
4800	1200	3930
9600	1200	3930
19200	1200	3930
38400	1200	3930
57600	1200	3930
76800	1200	3930
115000	900	2950
230000	400	1350
460000	300	1000
920000	300	1000
1200000	300	1000
2400000	90	300

Note: The above table assumes no intermediate connectors between remote async nodes. Each additional connection decreases the maximum allowable controller line length by approximately two percent due to increased line capacitance.

Cable ND

Description: 128-Port Async Controller to Remote Async Node Cable, 4-wire.

The cable has four conductors, two twisted-pair, and is shielded on the outside. If built to a length of 300 m (1000 ft) or less, conductors should be 28 AWG (stranded wire) with a capacitance rating of 52 pF/m (16 pF/ft) or less (Belden type 9804 or equivalent). For lengths greater than 300 m (1000 ft), conductors should be 24 AWG (stranded wire) with a capacitance rating of 52 pF/m (16 pF/ft) or less (Belden type 9829 or equivalent).

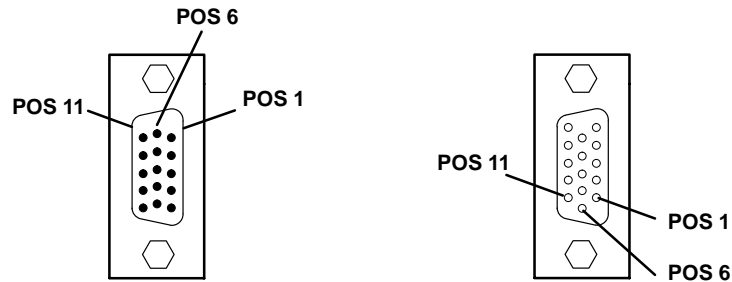

System End Connector		Device End Connector	
Pin (Male)	Signal	Signal	Socket (Female)
1	RxD -	TxD -	1
2	RxD +	TxD +	2
6	TxD -	RxD -	6
7	TxD +	RxD+	7
Shell	Shield Ground	Shield Ground	Shell

Line Length, 4-wire

The 128-port Async Controller supports two controller line baud rates in 4-wire, direct-attach mode. The following table shows the maximum allowable controller line length for each supported baud rate. The controller line length is the actual cable length from the controller to the last remote async node in the controller line.

Controller Line Baud Rate	Total Controller Cable Length	
	m	ft
230000	400	1350
460000	300	1000

Note: The above table assumes no intermediate connectors between remote async nodes. Each additional connection decreases the maximum allowable controller line length by approximately two percent due to increased line capacitance.

Cable NE

Description: 128-Port Async Controller EIA-232 Modem Cable, System-Side.

The cable has eight twisted-pair conductors and is shielded on the outside. Cable length can be from 1.8 m (6 ft) to 3.7 m (12 ft). Conductors should be 24 AWG (stranded wire) with a capacitance rating of 41 pF/m (12.5 pF/ft) or less.

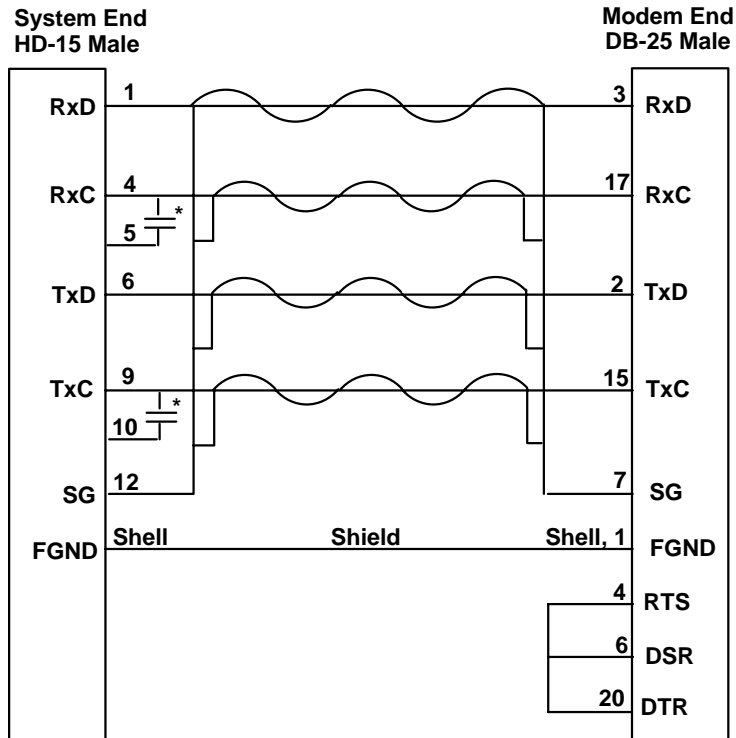

* 2200pf Capacitor

Note: See next page for notes.

The 128-port async controller supports multiple controller line baud rates in EIA-232 synchronous-modem-attach mode. Although the 128-port async controller can operate at 57.6 Kbps, to ensure a low error rate on the synchronous link, controller line baud rates of 19.2 Kbps or less are recommended.

Note: The length to the furthest RAN including modem cable should be limited to 50 feet. If there is a requirement to go up to 1000 feet, then EIA-422 modems must be used.

Attention: Testing Recommendation - When setting up equipment: Hook up all equipment near the host system. Make sure that the 128-port adapter, cables, modems, and RAN are all functioning properly. Equipment is easier to trouble shoot when all components are local. Consult modems technical manual for settings and wiring when modems are used back to back in a test configuration as described here. Baud rates of 19.2 Kbps or less are recommended to help insure low error rates. Using EIA232 modems, the length to the furthest RAN including modem cable should be limited to 50 feet. If there is a requirement to go up to 1000 feet, then EIA422 modems must be used.

Cable NF

Description: 128-Port Async Controller EIA-232 Modem Cable, Device-side.

The cable has eight twisted-pair conductors and is shielded on the outside. Cable length can be from 1.8 m (6 ft) to 3.7 m (12 ft). Conductors should be 24 AWG (stranded wire) with a capacitance rating of 41 pF/m (12.5 pF/ft) or less.

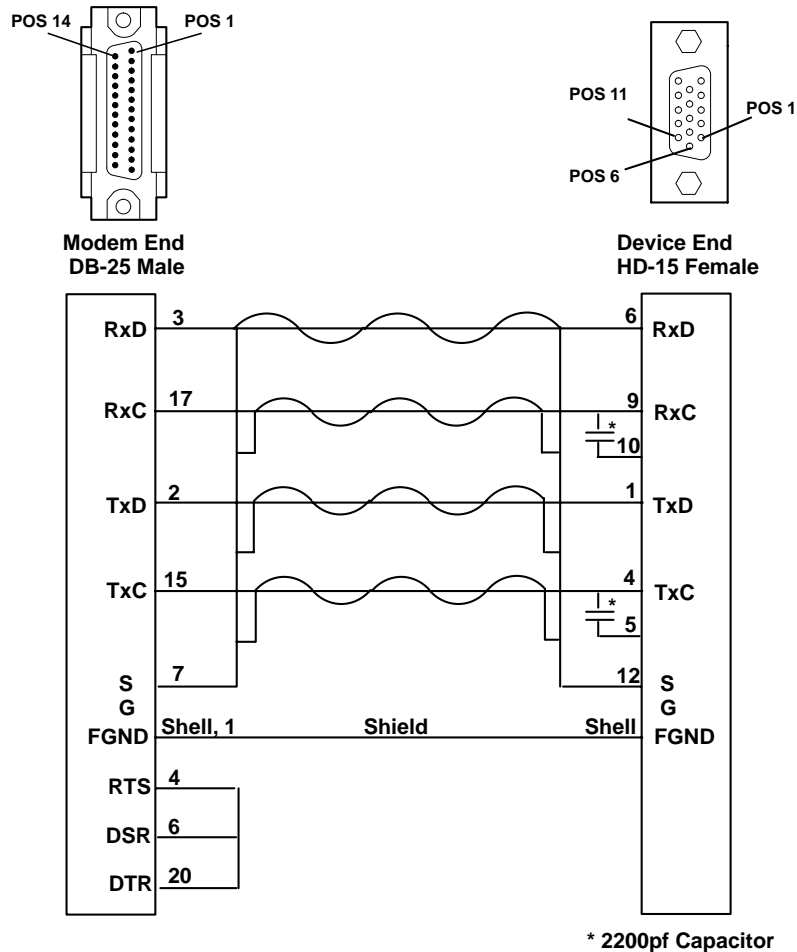

The 128-port async controller supports multiple controller line baud rates in EIA-232 synchronous-modem-attach mode. Although the 128-port async controller can operate at 57.6 Kbps, to ensure a low error rate on the synchronous link, controller line baud rates of 19.2 Kbps or less are recommended.

Note: The length to the furthest RAN including modem cable should be limited to 50 feet. If there is a requirement to go up to 1000 feet, then EIA-422 modems must be used.

See Testing Recommendation in Chapter 5 Cable NE on page 5-33.

Cable NG

Description: 128-Port Async Controller EIA-422 Modem Cable, System.

The cable has eight conductors, four twisted-pair, and is shielded on the outside. If built to a length of 300 m (1000 ft) or less, conductors should be 28 AWG (stranded wire) with a capacitance rating of 52 pF/m (16 pF/ft) or less (Belden type 9806 or equivalent). For lengths greater than 300 m (1000 ft), conductors should be 24 AWG (stranded wire) with a capacitance rating of 52 pF/m (16 pF/ft) or less (Belden type 9831 or equivalent).

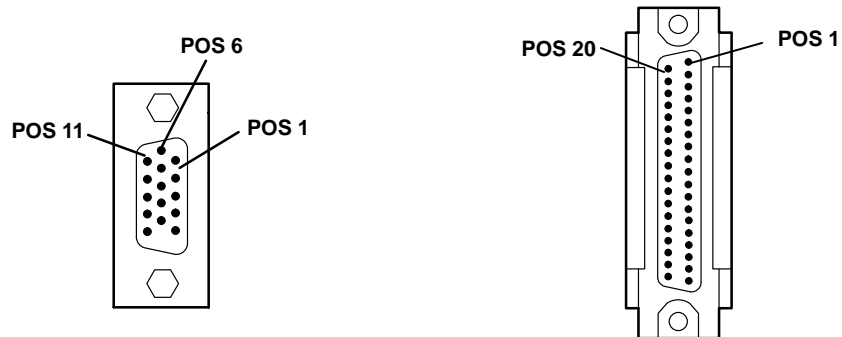

System End Connector			Device End Connector	
Pin	(Male)	Signal	Signal	Socket (Female)
1		RxD -	RD -	6
2		RxD +	RD +	24
4		RxC -	RT -	8
5		RxC +	RT +	26
6		TxD -	SD -	4
7		TxD +	SD +	22
9		TxC -	ST -	5
10		TxC +	ST +	23
12		Shield Ground	Shield Ground	19

The 128-port async controller supports multiple controller line baud rates in EIA-422 synchronous-modem-attach mode. See the Controller Line Baud Rate table for Cable NB "Line Length, 8-wire" on page 5-30.

Cable NH

Description: 128-Port Async Controller EIA-422 Modem Cable, Device-Side.

The cable has eight conductors, four twisted-pair, and is shielded on the outside. If built to a length of 300 m (1000 ft) or less, conductors should be 28 AWG (stranded wire) with a capacitance rating of 52 pF/m (16 pF/ft) or less (Belden type 9806 or equivalent). For lengths greater than 300 m (1000 ft), conductors should be 24 AWG (stranded wire) with a capacitance rating of 52 pF/m (16 pF/ft) or less (Belden type 9831 or equivalent).

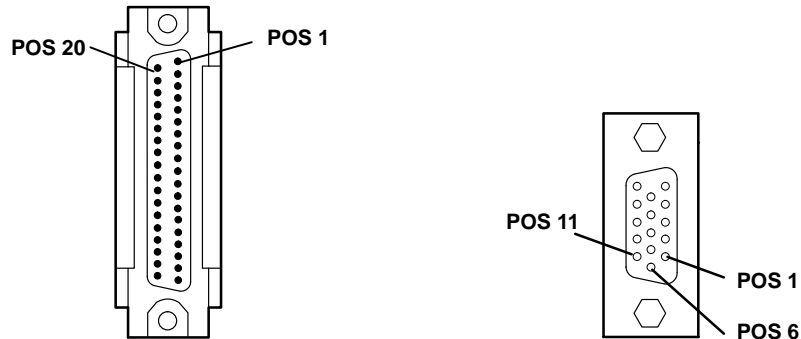

System End Connector			Device End Connector	
Pin	(Male)	Signal	Signal	Socket (Female)
6		RD -	RxD -	6
24		RD +	RxD +	7
8		RT -	RxC -	9
26		RT +	RxC +	10
4		SD -	TxD -	1
22		SD +	TxD +	2
5		ST -	TxC -	4
23		ST +	TxC +	5
19		Shield Ground	Shield Ground	12

The 128-port async controller supports multiple controller line baud rates in EIA-422 synchronous-modem-attach mode. See the Controller Line Baud Rate table for Cable NB "Line Length, 8-wire" on page 5-30.

Remote Async Node-to-Device Cables

Cable NK

Description: 10-pin RJ-45 to DB-25 Converter Cable for use with the Remote Async Node 16-Port EIA-232.

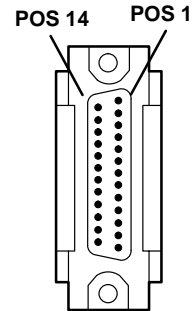
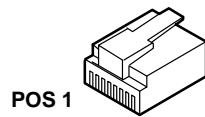

System End Connector			Device End Connector	
Pin	(Male)	Signal	Signal	Socket (Female)
1		RI	RI	22
2		DSR	DSR	6
3		RTS	RTS	4
4		Chassis Ground	Chassis Ground	Shell
5		TxD	TxD	2
6		RxD	RxD	3
7		Signal Ground	Signal Ground	7
8		CTS	CTS	5
9		DTR	DTR	20
10		CD	CD	8

Note:

1. This cable assembly is shielded.
2. This cable assembly and the 64-port RJ-45 to DB-25 converter cable (FC 6402) are not interchangeable.

Cable NL

Description: Customer-supplied cable for connecting Remote Async Node 16-Port EIA-232 to a printer or terminal device.

Cable length can be up to 30 m (100 ft) for baud rates up to 57.6 Kbps. See "RAN to Device Cable Lengths" on page 5-41. Use overall foil/braid shielded multiconductor cable with a capacitance rating of 41 pF/m (12.5 pF/ft) or less. Conductors should be 28 AWG (stranded wire). For lengths less than 61 m (200 ft), higher capacitance cable can be used, as long as the total capacitance (including intermediate connectors and cables) does not exceed 2500 pF.

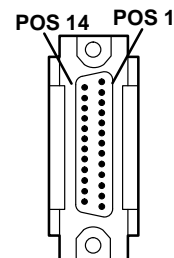
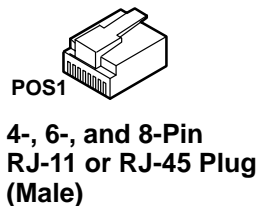

DB-25 Pin (Male)

	4-Pin RJ-11	6-Pin RJ-11	8-Pin RJ-45	Terminal/Printer DTE DB-25	
RI					
DSR*			1	20	DTR
RTS		1	2	5	CTS
FGND	Shell 1	2	3	Shell	FGND
TxD	2	3	4	3	RxD
RxD	3	4	5	2	TxD
SG	4	5	6	7	SG
CTS		6	7	4	RTS
DTR			8	6	DSR
DCD*				8	DCD

RAN to Printer/Terminal Cable (NL)
for 4- and 6-Pin RJ-11, and 8-Pin RJ-45 Plugs

Note: *The physical location of DCD and DSR may be interchanged through software control if desired. Used only on 8-pin RJ-45 cable.

2

20

ell

3

2

7

4

6

8

Terminal Cable (ML)
RJ-45 Plug

Cable NM

Description: Customer-supplied cable for connecting Remote Async Node 16-Port EIA-232 to a modem device.

Cable length can be up to 30 m (100 ft) for baud rates up to 57.6 Kbps. See "RAN to Device Cable Lengths" on page 5-41. Use overall foil/braid shielded multiconductor cable with a capacitance rating of 41 pF/m (12.5 pF/ft) or less. Conductors should be 28 AWG (stranded wire). For lengths less than 61 m (200 ft), higher capacitance cable can be used, as long as the total capacitance (including intermediate connectors and cables) does not exceed 2500 pF.

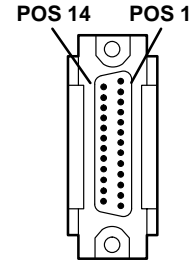
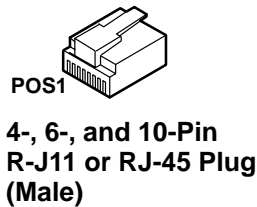

DB-25 Pin (Male)

	4-Pin RJ-11		6-Pin RJ-11		10-Pin RJ-45		Cable NM Modem DCE DB-25	
RI	1				1		22	RI
DSR	2				2		6	DSR
RTS	3		1		3		4	RTS
FGND	4	1	2		4		Shell	FGND
TxD	5	2	3		5		2	TxD
RxD	6	3	4		6		3	RxD
SG	7	4	5		7		7	SG
CTS	8		6		8		5	CTS
DTR	9				9		20	DTR
DCD	10				10		8	DCD

RAN to Modem Cable (NM)
for 4-Pin, 6-Pin RJ-11, and 10-Pin RJ-45 Plugs

Attention: The receivers and drivers used in most asynchronous communications devices are sensitive to electrostatic discharge (ESD). To reduce the possibility of exposure to ESD, observe the following cabling practices when building or using device cables for attachment to the Remote Async Node 16-Port EIA-232:

1. Do not build a cable that has exposed conductors, leads, or pins that could be touched by someone not protected against ESD. Avoid the use of punchdown blocks and patch panels which have exposed terminator/pins. In the event that you use intermediate connectors or cables, be sure to discharge them to ground before plugging them into equipment.
2. Do not run any cables outdoors without having proper transient voltage suppression devices installed.
3. Do not route cables near or around items such as power transformers, high-power switching devices and refrigeration units.
4. Use shielded cables. All wires should be terminated, not floating. The shield should be connected to shield ground at the remote async node.

Note:

1. This cable assembly is shielded.
2. This cable assembly and the 64-port RJ-45 to DB-25 converter cable (FC 6402) are not interchangeable.

RAN to Device Cable Lengths

RAN to Device Line Baud Rate bps	Total RAN to Device Cable Length	
	m	ft
57600 or less	30	100
115000	24	80
230000	12	40

The following diagram illustrates cable NM using an 8-pin RJ-45 plug.

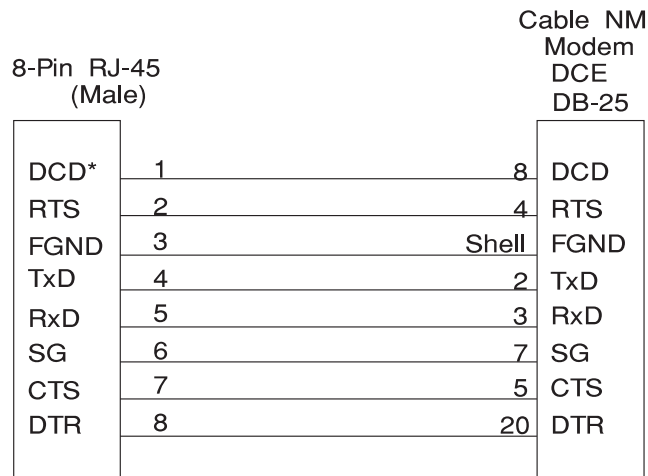

RAN to Modem Cable (NM)
for 8-Pin RJ-45 Plug

Note: *The physical location of DCD is switched with DSR through software control.

Attention: The receivers and drivers used in most asynchronous communications devices are sensitive to electrostatic discharge (ESD). To reduce the possibility of exposure to ESD, observe the following:

1. Do not build a cable that has exposed conductors, leads, or pins that could be touched by someone not protected against ESD. Avoid the use of punchdown blocks and patch panels which have exposed terminator/pins. In the event that you use intermediate connectors or cables, discharge them to ground before plugging them into equipment.
2. Do not run any cables outdoors without having proper transient voltage suppression devices installed.
3. Do not route cables near or around items such as power transformers, high-power switching devices and refrigeration units.
4. Use shielded cables.
5. All wires should be terminated, not floating. The shields should be connected to shield ground at the remote async node.

Cable NP

Description: 10-pin RJ-45 to DB-25 converter cable for use with the Enhanced Remote Async Node 16-Port RS-422. Only six wires are used by the NP cable.

Note: An NK cable (an EIA-232 cable) can be used for an NP cable if available. It has some extra wires but should work.

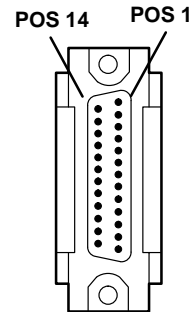
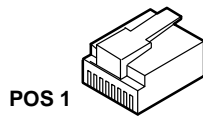

System End Connector		Device End Connector		
Pin	(Male)	Signal	Signal	Socket (Female)
1		Reserved	Reserved	22
2		Reserved	Reserved	6
3		TxD+	TxD+	4
4		Chassis Ground	Chassis Ground	Shell
5		TxD-	TxD-	2
6		RxD-	RxD-	3
7		Signal Ground	Signal Ground	7
8		RxD+	RxD+	5
9		Reserved	Reserved	20
10		Reserved	Reserved	8

Note:

- This cable assembly is shielded.

Cable RA

Description: This is a Serial to Re_IPL port Re_IPL Cable.

There are two lengths of serial to Re_IPL port Re_IPL cables available. One cable is 3.7 meters and the other is 8 meters long.



System End Connector	Signal	Device End Connector
Socket (Female)		Socket (Female)
7	Ground	1
2, 3	TxD	3
6, 8, 20	DTR	2
4, 5, 22	RTS	4

Cable RB

Description: This is a serial to serial port Re_IPL Cable.

The serial to serial port Re_IPL cable comes in two lengths, 3.7 or 8 meters long.



System End Connector	Signal	Device End Connector
Socket (Female)		Socket (Female)
Shell	Shield Ground	Shell, 1
2	TxD	3
3	RxD	2
4	RTS	5
5	CTS	4
6, 8	DSR, CD	20
7	Signal Ground	7
20	DTR	6, 8

Multiport/2 4P/8P Interface Cable

The 4P/8P Multiport Interface Cable supports all of the following Multiport/2 Electronic Interface Boards:

- 8P EIA-422
- 8P EIA-232
- 4P EIA-232
- 4P EIA-232/4P EIA-422.

Cable T1

Description: 4/8-Port 232/422 Multiport/2 Cable. The system end of the 4/8-Port 232/422 Multiport/2 Cable consists of a 78-position D-shell connector. The cable device end consists of a Molded Distribution Box (MDB) with eight 25-pin D-shell connectors to allow up to eight standard device connections, depending on the number of ports supported by the Multiport/2 adapter.

EIA-422 Multiport/2 Adapter 78- and 25-Position Connector

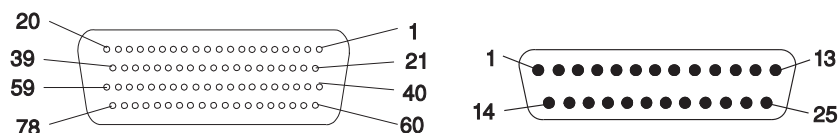

Mnemonic	Port 0	Port 1	Port 2	Port 3	25-Position Connector
TxD	40	04	66	69	02/BA-103
RxD	02	64	28	31	03/BB-104
RTS	01	63	27	30	04/CA-105
CTS	61	25	48	51	05/CB-106
DTECLK	41	05	--	--	24/DA-113
SG	43	07	08	67	07/AB-102
DCD	22	45	09	12	08/CF-109
RxCLKIN	62	26	--	--	17/DD-115
DTR	60	24	47	50	20/CD-108.2
DSR	42	06	68	71	06/CC-107
HRS	21	44	--	--	23/CH-111
RI	03	65	29	32	22/CE-125
TxCLKIN	23	46	--	--	15/DB-114

Mnemonic	Port 4	Port 5	Port 6	Port 7	25-Position Connector
TxD+	73	55	76	58	02/TXA
TxD-	34	16	37	19	04/TXB
RxD+	54	75	57	78	03/RXA
RxD-	15	36	18	39	05/RXB
SG	11	70	--	--	07/

8-Port EIA-232-C Multiport/2 Adapter 78- and 25-Position Connectors

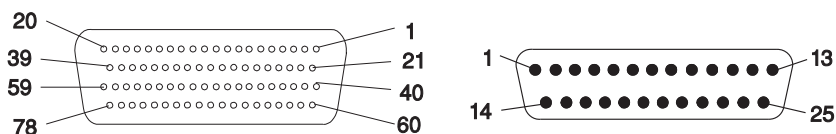

Mnemonic	Port 0	Port 1	Port 2	Port 3	Port 4	Port 5	Port 6	Port 7	25-Position Connector
TxD	40	04	66	69	73	55	76	58	02/BA-103
RxD	02	64	28	31	54	75	57	78	03/BB-104
RTS	01	63	27	30	34	16	37	19	04/CA-105
CTS	61	25	48	51	15	36	18	39	05/CB-106
DTECLK	41	05	--	--	--	--	--	--	24/DA-113
SG	43	07	08	67	11	70	--	--	07/AB-102
DCD	22	45	09	12	74	56	77	59	08/CF-109
RxCLKIN	62	26	--	--	--	--	--	--	17/DD-115
DTR	60	24	47	50	35	17	38	20	20/CD-108.2
DSR	42	06	68	71	72	33	53	14	06/CC-107
HRS	21	44	--	--	--	--	--	--	23/CH-111
RI	03	65	29	32	49	52	10	13	22/CE-125
TxCLKIN	23	46	--	--	--	--	--	--	15/DB-114

4-Port EIA-232-C Multiport/2 Adapter 78- and 25-Position Connectors

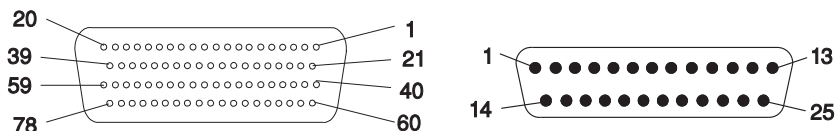

Mnemonic	Port 0	Port 1	Port 2	Port 3	25-Position Connector
TxD	40	04	66	69	02/BA-103
RxD	02	64	28	31	03/BB-104
RTS	01	63	27	30	04/CA-105
CTS	61	25	48	51	05/CB-106
DTECLK	41	05	--	--	24/DA-113
SG	43	07	08	67	07/AB-102
DCD	22	45	09	12	08/CF-109
RxCLKIN	62	26	--	--	17/DD-115
DTR	60	24	47	50	20/CD-108.2
DSR	42	06	68	71	06/CC-107
HRS	21	44	--	--	23/CH-111
RI	03	65	29	32	22/CE-125
TxCLKIN	23	46	--	--	15/DB-114

4-Port EIA-232-C/4-Port-422-A Multiport/2 Adapter



Cable T2

Description: 6-Port Sync Multiport/2 Cable.

The system end of the 6-Port Sync Multiport/2 cable consists of a 78-position D-shell connector. The cable device end consists of an MDB with six 25-pin D-shell connectors to allow six devices to be connected to the six ports supported by this adapter.

6-Port Synchronous EIA-232-C Multiport/2 Adapter 78-and 25-Position Connectors

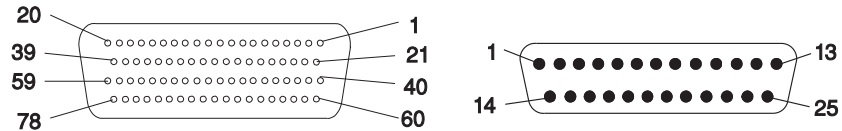

Mnemonic	Port 0	Port 1	Port 2	Port 3	Port 4	Port 5	25-Position Connector
TxD	40	04	66	69	73	55	02/BA-103
RxD	02	64	28	31	54	75	03/BB-104
RTS	01	63	27	30	34	16	04/CA-105
CTS	61	25	48	51	15	36	05/CB-106
DTECLK	41	05	19	20	10	13	24/DA-113
SG	43	07	08	67	11	70	07/AB-102
DCD	22	45	09	12	74	56	08/CF-109
RxCLKIN	62	26	57	77	18	53	17/DD-115
DTR	60	24	47	50	35	17	20/CD-108.2
DSR	42	06	68	71	72	33	06/CC-107
HRS	21	44	76	37	38	58	23/CH-111
RI	03	65	29	32	49	52	22/CE-125
TxCLKIN	23	46	78	59	39	14	15/DB-114

Cable T3

Description: 6-Port V.35 Portmaster Cable.

The system end of the 6-Port V.35 Portmaster cable consists of a 100-position D-shell connector. The cable device end consists of an MDB with six 25-pin D-shell connectors to allow six devices to be connected to the six ports supported by the adapter.

6-Port V.35 Portmaster Adapter/A 100- and 25-Position Connectors

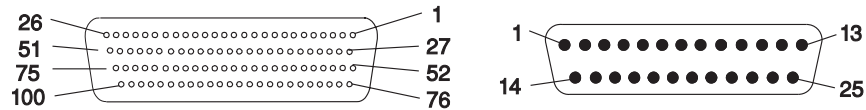

Mnemonic	I/O	Port 0	Port 1	Port 2	Port 3	Port 4	Port 5	25-Position Connector
TxDA	O	94	21	47	71	72	23	02
TxDB	O	70	46	22	95	96	48	14
RxDA		08	54	58	29	28	57	03
RxDB		33	78	82	04	03	81	16
TxCA IN		76	06	77	56	27	55	15
TxCB IN		52	31	53	80	02	79	12
RxCA		20	41	38	19	32	30	17
RxCB		45	16	13	44	07	05	09
TxCA OUT	O	24	73	98	25	99	26	24
TxCB OUT	O	49	97	74	50	75	51	11
RTS	O	42	43	92	93	37	39	04
CTS		15	65	86	87	59	09	05
DCD		89	40	62	61	35	84	08
DTR	O	18	91	69	68	14	12	20
DSR		66	90	88	64	60	85	06
SGND	--	34	17	63	67	01	83	07
FGND		-- 100 Shield						01

Cable T4

Description: 8-Port 232/422 Portmaster Cable.

The system end of the 8-Port 232/422 Portmaster cable consists of a 100-position D-shell connector. The cable device end consists of an MDB with eight 25-pin D-shell connectors to allow up to eight devices to be connected to the eight ports supported by the adapter.

8-Port EIA-422-A Portmaster Adapter/A 100- and 25-Position Connectors

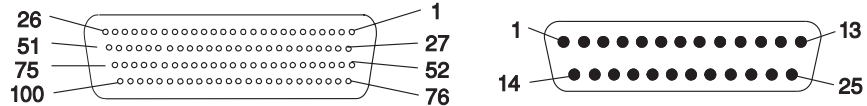

Mnemonic	I/O	Port 0	Port 1	Port 2	Port 3	Port 4	Port 5	Port 6	Port 7	25-Position Connector
TxD	O	51	54	07	10	13	16	94	48	02/SDA
RxD	O	52	55	08	11	14	17	95	49	24/SDB
		02	05	83	86	89	92	46	74	03/RDA
		78	81	35	38	41	44	72	25	17/RDB
-RTS	O	01	04	82	85	88	91	45	73	04/RSA
-CTS	O	76	79	33	36	39	42	70	23	20/RSB
		77	80	34	37	40	43	71	24	05/CSA
		53	56	09	12	15	18	96	50	06/CSB
TxCLK		28	31	59	62	65	68	21	99	08/STA
RxCLK		03	06	84	87	90	93	47	75	22/STB
		29	32	60	63	66	69	22	100	15/RTA
		27	30	58	61	64	67	20	98	23/RTB
SGND FGND	--	19	19	26	26	57	57	97	97	07/GND 01/FGND
Cable Shield										

Cable T5

Description: 6-Port X.21 Portmaster Cable.

The system end of the 6-Port X.21 Portmaster cable consists of a 78-position D-shell connector. The cable device end consists of an MDB with six 25-pin D-shell connectors to allow six devices to be connected to the six ports supported by the adapter.

6-Port X.21 Portmaster Adapter/A 78 - and 25-Position Connectors

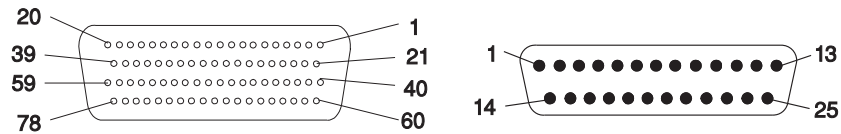

Mnemonic	I/O	Port 0	Port 1	Port 2	Port 3	Port 4	Port 5	25-Position Connector
T(A)	O	40	04	66	69	73	55	02
T(B)	O	41	05	19	20	10	13	24
R(A)		02	64	28	31	54	75	03
R(B)		62	26	57	77	18	53	17
C(A)	O	01	63	27	30	34	16	04
C(B)	O	60	24	47	50	35	17	20
I(A)		61	25	48	51	15	36	05
I(B)		42	06	68	71	72	33	06
S(A)		23	46	78	59	39	14	15
S(B)		21	44	76	37	38	58	23
X(A)	O	22	45	09	12	74	56	08
X(B)	O	03	65	29	32	49	52	22
SGND	--	43	07	08	67	11	70	07

8-Port EIA-232-D Portmaster Adapter/A 100- and 25-Position Connectors

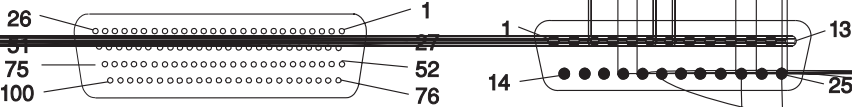

Mnemonic	I/O	Port 0	Port 1	Port 2	Port 3	Port 4	Port 5	Port 6	Port 7	25-Position Connector
TxD	O	51	54	07	10	13	16	94	48	02/BA
RxD		02	05	83	86	89	92	46	74	03/BB
RTS	O	01	04	82	85	88	91	45	73	04/CA
CTS		77	80	34	37	40	43	71	24	05/CB
DCD		28	31	59	62	65	68	21	99	08/CF
DTR	O	76	79	33	36	39	42	70	23	20/CD
DSR		53	56	09	12	15	18	96	50	06/CC
HRS		27	30	58	61	64	67	20	98	23/CI
RI		03	06	84	87	90	93	47	75	22/CE
TxCLKIN		29	32	60	63	66	69	22	100	15/DB
TxCLK	O	52	55	08	11	14	17	95	49	24/DA
RxCLK		78	81	35	38	41	44	72	25	17/DD
SGND	--	19	19	26	26	57	57	97	97	07/AB
FGND		Cable Shield								01/AA

Cable T6

Description: 6 Port V.35 Network Attachment Cable for use with the 6 Port-V.35 Portmaster.

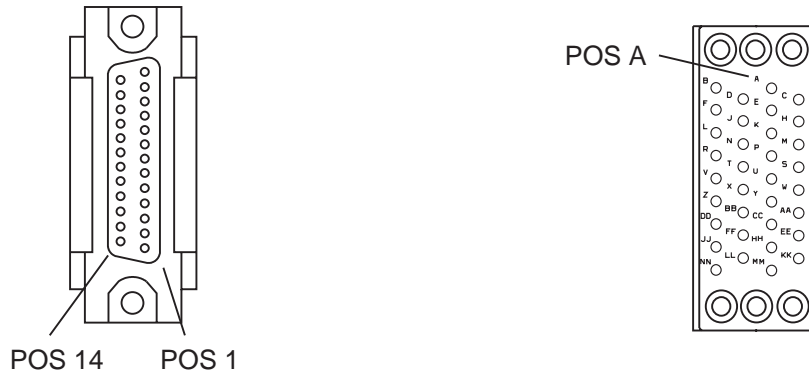

System End Connector	Signal	Device End Connector
Socket (Female)		Pin (Male)
4	RTS	C
5	CTS	D
6	DSR	E
8	CD	F
20	DTR	H
24	DTECLK(A)	U
11	DTECLK(B)	W
2	TxD (A)	P
14	TxD (B)	S
3	RxD (A)	R
16	RxD (B)	T
15	Tx Clk (A)	Y
12	Tx Clk (B)	AA
17	Rx Clk (A)	V
9	Rx Clk (B)	X
7	Ground	B
8	Frame Ground	Shield

Cable T7

Description: 6-Port X.21 Network Attachment Cable for use with the 6-Port-X.21 Portmaster.

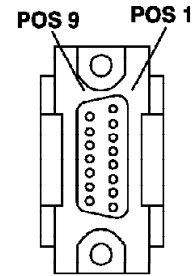
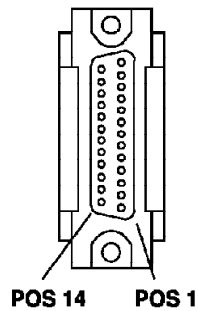

System End Connector	Signal	Device End Connector
Socket (Female)		Pin (Male)
2	T (A)	2
24	T (B)	9
4	C (A)	3
20	C (B)	10
3	R (A)	4
17	R (B)	11
5	I (A)	5
6	I (B)	12
15	S (A)	6
23	S (B)	13
15	X(A)	7
23	X(B)	14
7	Ground	8

Connector Descriptions

Cable Letter	Cable Name	Connector Descriptions (adapter end/device end)
A	PC Parallel Printer Cable	25-pin D male/36-pin D male barrier
B	Serial Port Jumper Cable	10-pin MODU female/25-pin D male
D	Async Cable-EIA-232/V.24	25-pin D female/25-pin D male
E	Printer/Terminal Interposer-EIA-232	25-pin D female/25-pin D male
I	Printer/Terminal Cable-EIA-232	25-pin D female/25-pin D male
J	Multiport Interface Cable	78-pin D male/78-pin D female
K	Terminal Cable-EIA-422A	25-pin D male/25-pin D male
L	16-Port Interface Cable-EIA-232	78-pin D male/25-pin D male
M	16-Port Interface Cable-EIA-422A	78-pin D male/25-pin D male
N	64-Port Controller Cable	RJ-45 male/RJ-45 male
P	64-Port Converter Cable for the 16 port concentrator	8-pin RJ-45 male/25-pin D male
Q	X.25 Attachment Cable-X.21	37-pin D female/15-pin D male
R	X.25 Attachment Cable-V.24	37-pin D female/25-pin D male
S	X.25 Attachment Cable-V.35	37-pin D female/34-pin Type M male
T	4-Port Multiprotocol Interface Cable	78-pin D male/78-pin D female
U	Multiprotocol Attachment Cable-V.35	15-pin D female/34-pin Type M male
V	Multiprotocol Attachment Cable-EIA-232/V.24	25-pin D female/25-pin D male
W	Multiprotocol Attachment Cable-X.21	15-pin D female/15-pin D female
X	EIA-422A Cable	25-pin D female/customer supplied
Z	Token Ring converter Cable	8-pin RJ-45 male/9-pin D
AR	9-Pin to 25-Pin Serial converter Cable	9-pin D female/25-pin D male
AS	Serial Port fanout Cable makes second serial port available see Standard I/O Ports page	25-pin D female/two 25-pin D male
KK	Serial Optical Channel Converter Cable (all lengths)	SC Optical Receptacle Connector (color-coded)
NB, NC	128-Port Async Controller Cable, 8-wire	15-pin HD male/15-pin HD female
ND	128-Port Async Controller Cable, 4-wire	15-pin HD male/15-pin HD female
NE	128-Port Async Controller EIA-232 Modem Cable, System	15-pin HD male/25-pin D male
NF	128-Port Async Controller EIA-232 Modem Cable, Device	25-pin D male/15-pin HD female
NG	128-Port Async Controller EIA-422 Modem Cable, System	15-pin HD male/37-pin D male
NH	128-Port Async Controller EIA-422 Modem Cable, Device	37-pin D male/15-pin HD female
NK	RJ-45 to DB-25 Converter Cable	10-pin RJ-45 male/25-pin D male
NL	Customer-supplied cable for connecting Remote Async Node 16-Port EIA-232 to a printer or terminal device	4-, 6-, 8-, 10-pin RJ-45 male/25-pin D male
NM	Customer-supplied cable for connecting Remote Async Node 16-Port EIA-232 to a modem device	4-, 6-, 8-, 10-pin RJ-45 male/25-pin D male
NP	RJ-45 to DB-25 Converter Cable	10-pin RJ-45 male/25-pin D male
RA	Serial to Re-IPL Port Re-IPL Cable	25-pin D female/9-pin D female
RB	Serial to Serial port Re-IPL Cable	25-pin D female/25-pin D female
T1	4/8-Port 232/422 Multiport/2 Cable	78-pin D male/25-pin D male

Cable Letter	Cable Name	Connector Descriptions (adapter end/device end)
T2	6-Port Sync Multiport/2 Cable	78-pin D male/25-pin D male
T3	6-Port V.35 Portmaster Cable	100-pin D male/25-pin D male
T4	8-Port 232/422 Portmaster Cable	100-pin D male/25-pin D male
T5	6-Port X.21 Portmaster Cable	78-pin D male/25-pin D male
T6	6-Port Network Cable V.35 Portmaster	25-pin D female/34-pin Type M male
T7	6-Port Network Cable X.21 Portmaster	25-pin D female/15-pin D male
XX	16-Port Concentrator to printer or terminal device	8-pin RJ-45 male/25-pin D male
YY	16-Port Concentrator to modem	8-pin RJ-45 male/25-pin D male

Standard I/O pinouts

Keyboard Connector

The physical layout of the keyboard connector is shown in the following illustration.

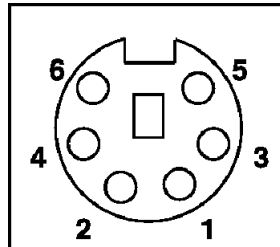

Pin	Signal
1	Keyboard Data
2	Speaker Signal
3	Ground
4	+5V dc
5	Keyboard Clock
6	Speaker Ground

Mouse Connector

The physical layout of the mouse adapter connector is shown in the following illustration.

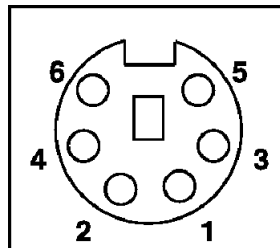

Pin	Signal
1	Mouse Data
2	Reserved
3	Ground
4	+5V dc
5	Mouse Clock
6	Reserved

Tablet Connector

The physical layout of the tablet connector is shown in the following illustration.

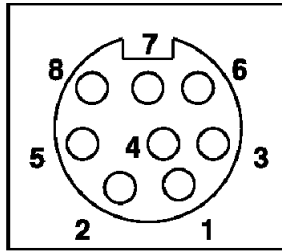

Pin	Signal
1	Ground
2	Direct Current
3	(dc) Return (Ground)
4	+5 V dc Reserved
5	Receive from device
6	Transmit to device
7	Reserved
8	Reserved

Serial Port Connectors

A physical layout of the serial port connectors is shown in the following two illustrations.

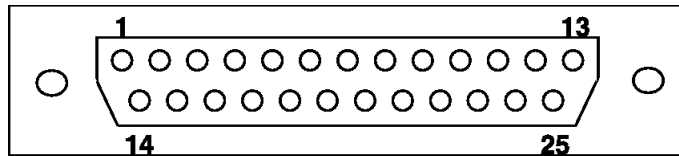

25 Pin D-Shell

Pin	Signal
2	Transmit Data
3	Receive Data
4	Request to Send
5	Clear to Send
6	Data Set Ready
7	Signal Ground
8	Data Carrier Detect
20	Data Terminal Ready
22	Ring Indicate

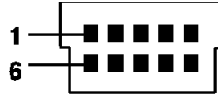

10 Pin MODU Male

Pin	Signal
1	Transmit Data
2	Data Terminal Ready
3	Request to Send
4	Ring Indicate
5	Reserved
6	Receive Data
7	Data Set Ready
8	Clear to Send
9	Data Carrier Detect
10	Signal Ground

Parallel Port Connector

A physical layout of the parallel port connector is shown in the following illustration.

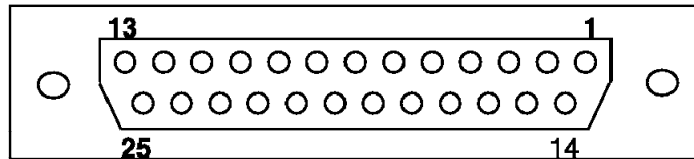

25 Pin D-Shell

Pin	Signal	Pin	Signal
1	Strobe	14	Autofeed XT
2	PDATA0	15	Error
3	PDATA1	16	INIT
4	PDATA2	17	Select In
5	PDATA3	18	Ground
6	PDATA4	19	Ground
7	PDATA5	20	Ground
8	PDATA6	21	Ground
9	PDATA7	22	Ground
10	ACK	23	Ground
11	Busy	24	Ground
12	PE	25	Ground
13	Select	--	--

External Diskette Connector

The following illustration shows the external diskette connector.

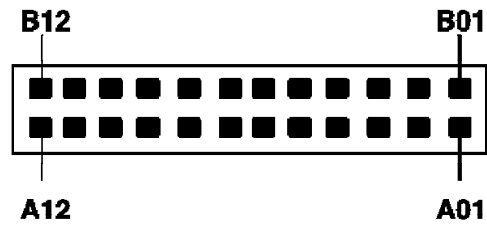

Pin	Signal	Pin	Signal
A01	Rd wt current/ High Density	B01	Track 0
A02	Enable 74F760S	B02	Write Protect
A03	Ground	B03	Read Data
A04	Index	B04	Head Select 1 OC
A05	Motor Enable 0 OC	B05	Diskette Change
A06	Drive Select 1 OC	B06	Reserved
A07	Drive Select 0 OC	B07	Ground
A08	Motor Enable 0 1C	B08	Ground
A09	Direction OC	B09	Ground
A10	Step	B10	Ground
A11	Write Data OC	B11	Ground
A12	Write Enable	B12	Ground

Index

Numerics

1/4-inch cartridge tape drives 2-12
1/4-inch cartridge tape drives, setting the SCSI address 2-12
1.37GB SCSI disk drive 2-88
10/100 Mbps ethernet MC adapter 1-185
10/100 Mbps ethernet MC adapter specifications 1-185
1080MB SCSI disk drives 2-72
12.0GB 4-mm tape drive 2-26
128-port async controller 1-86
128-port async controller 15-position HD-15 connector 1-87
128-port async controller to RAN cables 5-28
16-port async adapter - EIA-232-D 1-76
16-port async adapter - EIA-422A 1-78
160MB SCSI disk drive 2-46
1G SCSI disk drives 2-69
2.0G-byte 4-mm tape drive 2-14
2.0G-byte 4-mm tape drive, manually removing the tape cartridge 2-1
2.0GB SCSI-2 disk drive 2-91
2.3G-byte 8-mm tape drive 2-30
2.4G-byte SCSI disk drive 2-1, 2-94
20.0 GB 8-mm tape drive 2-43
200MB SCSI disk drive 2-47
320MB and 400MB SCSI disk drive 2-48
3270 connection 1-127
355MB and 670MB SCSI disk drive 2-49
4-port EIA-232-C multiport/2 adapter 1-47
4-port EIA-232-C/4-Port EIA-422-A multiport/2 adapter 1-53
4-port multiprotocol communications controller 1-41
4.0 GB 4-mm tape drive 2-18
4.0 GB 4-mm tape drive, external 2-17
5.25 inch diskette drive 2-2
5086/5085 attachment adapter 1-136
540MB SCSI disk drive 2-51
5G-byte 8-mm tape drive 2-39
6-port synchronous EIA-232-C multiport/2 adapter 1-51
6-port V.35 portmaster adapter/A 1-61
6-port X.21 portmaster adapter/A 1-63
64-port async controller 1-80
8-port async adapters 1-73
8-port EIA-232-C multiport/2 adapter 1-49
8-port EIA-232-D portmaster adapter/A 1-57
8-port EIA-422-A multiport/2 adapter 1-55
8-port EIA-422-S portmaster adapter/A 1-59
857MB SCSI disk drive 2-52

857MB slim-high SCSI disk drive 2-53

A

adapter cabling 3-1
(fiber distributed data interface (FDDI) adapter fiber 3-31
128-port async controller 3-8
16-port async adapter EIA-232 3-5
16-port async adapter EIA-422A 3-5
3270 connection adapter 3-29
4-Port Multiprotocol Communications Controller 3-14
5080 coax communication adapter 3-30
5085 or 5086 attachment adapter 3-52
5086/5085 attachment adapter 3-30
64-port async controller 3-7
7235 attachment adapter (POWER GTO accelerator) 3-53
7250 attachment adapter (POWER GXT1000 graphics accelerator) 3-53
8-port async adapter EIA-232 3-3
8-port async adapter EIA-42 3-3
8-port async adapter MIL-STD 188 3-4
9291/9295 digital trunk adapter 3-67
ARTIC960 FC 292X adapters 3-11
ARTIC960 FC 293X adapters 3-12
auto token-ring LANstreamer MC 32 adapter 3-20
block multiplexer channel adapter 3-41
color graphics display adapter 3-48
ethernet high-performance LAN adapter 3-26
fibre channel adapter 1063 3-39
fibre channel adapter/266 3-40
graphics input device adapter 3-52
high-performance disk drive subsystem adapter 3-56
high-performance subsystem adapter 40/80MB/Sec 3-58
HIPPI channel adapter 3-45
Integrated Ethernet LAN adapters 3-21
M-Audio capture and playback adapter 3-67
M-Video capture adapter 3-67
multiprotocol adapter/A 3-13
network terminal accelerator adapter 3-37
POWER Gt1, and Gt1b display adapters 3-48
POWER Gt1x display adapter 3-49
POWER Gt4e display adapter 3-49
POWER Gt4i and Gt4xi display adapters 3-50
POWER GTO accelerator (7235 attachment adapter) 3-53

- adapter cabling (*continued*)
 - POWER GXT150 graphics adapter 3-50
 - POWER GXT150L graphics adapter 3-51
 - POWER GXT150M graphics adapter 3-51
 - POWER GXT155L graphics adapter 3-51
 - POWER GXT800M 3D graphics adapter 3-54
 - realtime interface co-processor multiport/2 adapter/A 3-15
 - realtime interface co-processor portmaster adapter/A 3-18
 - S/370 channel emulator/A adapter 3-46
 - S/390 ESCON channel emulator adapter 3-47
 - SCSI I/O Controller FC 2828, 2829, and 2835 4-8
 - SCSI integrated controller for machine types 7006, 7008, 7009, and 7011 4-21
 - SCSI-1 integrated controller for machine types 7012, 7013, and 7015 4-18
 - SCSI-2 Differential Fast/Wide Controller FC 2413, 2416, and 9217 4-49
 - SCSI-2 Differential I/O Controller FC 2420 4-28
 - SCSI-2 Fast/Wide Integrated Controller for Machine Type 7012 Models 380/390/39H and 7030 Models 3AT/3BT/3CT 4-16
 - SCSI-2 Single-Ended Controller FC 2831 and 2410 4-24
 - SCSI-2 single-ended fast/wide controller FC 2414, 2415, and 9216 4-40
 - serial optical channel converter 3-36
 - Shielded Twisted-Pair (STP) (FDDI) adapter copper 3-33
 - system/370 host interface adapter 3-29
 - system/390 ESCON control unit adapter 3-44
 - token-ring high-performance network adapter 3-20
 - TURBOWAYS 100 and 155 ATM adapter 3-28
 - ultimedia audio adapter 3-68
 - ultimedia video I/O adapter 3-68
 - X.25 interface co-processor/2 3-13
 - adapter identification label cross-reference list 1-4
 - adapter identification reference list for IHV supplied adapters 1-3
 - adapter type number, cross-reference list 1-4
 - adapter-specific cable building 5-1
 - adapter, Micro Channel Multi-Initiator/RAID EL
 - description 1-124
 - lights 1-125
 - adapter, SSA 4-port
 - description 1-118
 - lights 1-119
 - adapter, SSA 4-port RAID
 - description 1-122
 - lights 1-123
 - adapter, SSA 4-port, enhanced
 - description 1-120
 - lights 1-121
 - address priority, SCSI 4-6
 - addresses, SCSI 12.0GB 4-mm 2-26
 - addresses, SCSI 20.0 GB 8-mm 2-43
 - addresses, SCSI 4.0GB 4-mm 2-18
 - ARTIC960 4-port multiprotocol communications controller 1-168
 - ARTIC960 6-port V.36 communications controller 1-178
 - ARTIC960 8-port EIA-232 E communications controller 1-176
 - ARTIC960 8-port X.21 communications controller 1-174
 - assembly, cable 5-1
 - async expansion adapter 1-138, 1-139
 - ATM 155 Video Streaming Adapter 1-184
 - attaching the dials and lighted program function
 - Keyboard 3-74
 - attaching the external 5.25 in. diskette drive 3-77
 - attaching the graphic displays 3-76
 - attaching the M-Video capture adapter (NTSC version) 3-78
 - attaching the M-Video capture adapter (PAL version) 3-80
 - attaching to the standard I/O interfaces devices 3-72
 - attaching user input devices 3-72
 - auto token-ring LANstreamer MC 32 adapter 1-161
- ## B
- block multiplexer channel adapter 1-128
 - building adapter-specific cables 5-1
 - building, cables 5-1
 - bus length, SCSI 4-5
- ## C
- cable assembly 5-1
 - cable building 5-1
 - cable description
 - 128-port async controller to RAN 5-28
 - Cable A 5-3
 - Cable AR 5-19
 - Cable AS 5-20
 - Cable D 5-6
 - Cable E 5-7
 - Cable I 5-8
 - Cable J 5-8
 - Cable K 5-9
 - Cable KK 5-21
 - Cable L 5-9
 - Cable M 5-9
 - Cable N 5-22
 - Cable ND 5-31
 - Cable NE 5-32
 - Cable NF 5-34
 - Cable NG 5-35
 - Cable NH 5-36

cable description (*continued*)

- Cable NK 5-37
 - Cable NL 5-38
 - Cable NM 5-40
 - Cable NP 5-43
 - Cable P 5-10
 - Cable Q 5-11
 - Cable R 5-12
 - Cable RA 5-44
 - Cable RB 5-45
 - Cable S 5-13
 - Cable T 5-13
 - Cable T1 5-46
 - Cable T2 5-49
 - Cable T3 5-50
 - Cable T4 5-51
 - Cable T5 5-52
 - Cable T6 5-54
 - Cable T7 5-55
 - Cable U 5-14
 - Cable V 5-15
 - Cable W 5-16
 - Cable X 5-17
 - Cable XX 5-24
 - Cable YY 5-26
 - Cable Z 5-18
 - Cables B and C 5-5
 - Cables NB and NC 5-29
- cable description and page number 5-2
- cable pin-outs 5-1
- cablings 3-1
- cablings SCSI devices 4-3
- cablings the 7131 SSA disk drive subsystems 3-64
- cablings the 7133 SSA disk drive subsystems 3-63
- cablings the 9333 high-performance disk drive subsystems 3-60
- cablings the SCSI I/O controller FC 2828, 2829, and 2835 4-8
- cablings the SCSI integrated controller for machine types 7006, 7008, 7009, and 7011 4-21
- cablings the SCSI-1 integrated controller for machine types 7012, 7013, and 7015 4-18
- cablings the SCSI-2 Differential Fast/Wide Controller FC 2413, 2416, and 9217 4-49
- cablings the SCSI-2 Differential I/O Controller FC 2420 4-28
- cablings the SCSI-2 Fast/Wide Integrated Controller for Machine Type 7012 Models 380/390/39H and 7030 Models 3AT/3BT/3CT 4-16
- cablings the SCSI-2 Single-Ended Controller FC 2831 and 2410 4-24
- cablings the SCSI-2 single-ended fast/wide controller FC 2414, 2415, and 9216 4-40
- cablings, SCSI 4-1
- cablings, SSA adapters FCs 6214, 6216, 6217, and 6219 3-61

- cache, SSA fast-write cache option card 1-124
- cartridge tape drives, 1/4-inch 2-12
- CD-ROM drives 2-3
- CD-ROM, manually removing the disc, type a drive 2-7
- CD-ROM, manually removing the disc, type b drive 2-9
- CD-ROM, manually removing the disc, type c drive 2-9
- CD-ROM, terminator resistors 2-11
- CD-ROM, vertical orientation 2-10
- communications adapter cabling 3-1
- connector descriptions 5-56
- considerations, EIA-232 cabling 3-1
- cross-reference, adapter identification label 1-4

D

- descriptions, connector 5-56
- device address, SCSI 4-6
- Devices Information 2-1
- digital trunk adapter 1-140
- digital trunk dual adapter 1-142
- drives
 - 12.0GB 4-mm tape drive 2-26
 - 20.0 GB 8-mm tape drive 2-43
 - 4.0GB 4-mm tape 2-18
 - 5.25 inch diskette 2-2
 - CD-ROM 2-3

E

- EIA-232 cabling 3-1
- enhanced remote async node 16-port EIA-232 1-88
- enhanced remote async node 16-port RS-422 1-88
- enhanced remote async node EIA-232 1-88
- enhanced remote async node RS-422 1-88
- enhanced SCSI-2 differential fast/wide adapter/A 1-114
- enhanced SSA 4-port adapter 1-120
- ESCON channel adapter 1-130
- ESCON channel emulator adapter 1-131
- ethernet high-performance LAN adapter 1-37
- ethernet, 10/100 Mbps MC adapter 1-185
- ethernet, 10/100 Mbps MC adapter specifications 1-185
- external 1/4-inch cartridge tape drive 1.2G-byte 2-13
- external 1/4-inch cartridge tape drive 150M-byte 2-13
- external 1/4-inch cartridge tape drive 525M-byte 2-13
- external SCSI devices 4-4, 4-5

F

- FC (8130) 1-88
- FC (8136) 1-89
- FC 2850 1-34

FC 6219 1-124
FC 6222 1-124
FC(8137) 1-88
FC(8138) 1-88
FDDI-fiber dual ring upgrade adapter 1-68
FDDI-fiber single ring adapter 1-67
FDDI-STP dual ring upgrade adapter 1-71
FDDI-STP single ring adapter 1-69
fiber distributed data interface (FDDI) dual ring upgrade adapter 1-46
fiber distributed data interface (FDDI) single ring adapter 1-45
fibre channel 1063 adapter short wave 1-182
fibre channel/266 adapter 1-167
front panel, remote async node 1-91

G

general SCSI considerations 4-5
graphics adapter cabling 3-48
graphics input device adapter 1-134
graphics subsystem adapters 1-13
GXT800M (FC2850) 3D graphics adapter with texture memory 1-34
GXT800M 3D graphics adapter with texture memory specifications 1-34
GXT800M graphics adapter connector 15-pin D-shell (HD-15) 1-36

H

high-performance disk drive subsystem adapter 1-102
high-performance disk drive subsystem adapter (40/80MB Byte/S) 1-113
high-performance disk drive subsystem adapter (80M Byte/S) 1-105
high-performance ethernet LAN adapter 10Base2 1-165
high-performance ethernet LAN adapter AUI and 10BaseT 1-163

I

I/O adapter cabling 3-56
identifying OEM components 4-28
identifying SCSI-2 differential components 4-28
IHV supplied adapters reference list 1-3
indicators
 Micro Channel Multi-Initiator/RAID EL adapter 1-125
 SSA 4-port adapter 1-119
 SSA 4-port adapter, enhanced 1-121
 SSA 4-port RAID adapter 1-123
Integrated Ethernet LAN adapters
 7010 Xstations 3-21
 models 250, 41T, 41W, 42T, and 42W 3-23

Integrated Ethernet LAN adapters (*continued*)
 models 34H, 350, 360, 370, 380, 390, 39H, 3AT, 3BT and 3CT 3-24
 models M20, M2A, 220, and 230 3-22
internal 8X speed SCSI-2 CD-ROM drive 2-6
internal double-speed SCSI CD-ROM drive 2-6
internal quad-speed SCSI-2 CD-ROM drive 2-6

J

JPEG compression option for ultimedia video I/O adapter 1-152
jumper setting, SCSI 12.0GB 4-mm 2-26
jumper setting, SCSI 20.0 GB 8-mm 2-43

K

keyboard, attach 3-72

L

length, SCSI bus 4-5
lights
 Micro Channel Multi-Initiator/RAID EL adapter 1-125
 SSA 4-port adapter 1-119
 SSA 4-port adapter, enhanced 1-121
 SSA 4-port RAID adapter 1-123

M

m-audio capture and playback adapter 1-146
m-video capture adapter (NTSC) 1-147
m-video capture adapter (PAL) 1-149
manually removing the CD-ROM disc 2-7
manually removing the tape cartridge, 2.0G-byte 4-mm tape drive 2-1
media streamer audio/video decoder 1-187
media streamer audio/video decoder audio connector 1-188
Micro Channel Multi-Initiator/RAID EL Adapter description 1-124
Micro Channel Multi-Initiator/RAID EL Adapter (type 4-I) lights 1-125
Multiport/2 4P/8P Interface Cable 5-46
multiprotocol adapter/A 1-65

N

network terminal accelerator 2048 adapter 1-157
network terminal accelerator 256 adapter 1-155
node number 1-92

O

overload protection, SCSI 4-7

P

page number of, cable descriptions 5-2
pin-out tables
 128-port async controller to RAN 5-28
 Cable A 5-3
 Cable AR 5-19
 Cable AS 5-20
 Cable D 5-6
 Cable E 5-7
 Cable I 5-8
 Cable J 5-8
 Cable K 5-9
 Cable KK 5-21
 Cable L 5-9
 Cable M 5-9
 Cable N 5-22
 Cable ND 5-31
 Cable NE 5-32
 Cable NF 5-34
 Cable NG 5-35
 Cable NH 5-36
 Cable NK 5-37
 Cable NL 5-38
 Cable NM 5-40
 Cable NP 5-43
 Cable P 5-10
 Cable Q 5-11
 Cable R 5-12
 Cable RA 5-44
 Cable RB 5-45
 Cable S 5-13
 Cable T 5-13
 Cable T1 5-46
 Cable T2 5-49
 Cable T3 5-50
 Cable T4 5-51
 Cable T5 5-52
 Cable T6 5-54
 Cable T7 5-55
 Cable U 5-14
 Cable V 5-15
 Cable W 5-16
 Cable X 5-17
 Cable XX 5-24
 Cable YY 5-26
 Cable Z 5-18
 Cables B and C 5-5
 Cables NB and NC 5-29
pin-outs, cable 5-1
positive temperature coefficient (PTC) 4-7
power cords, remote async node 1-97
POWER Gt3 graphics subsystem 1-26
POWER Gt3i graphics subsystem 1-28
POWER Gt4 and POWER Gt4x 24-bit graphics subsystem 1-18

POWER Gt4 and POWER Gt4x 8-bit graphics subsystem 1-16
POWER Gt4e graphics subsystem 1-27
POWER Gt4i 24-bit graphics subsystem 1-24
POWER Gt4xi 24-bit graphics subsystem 1-22
POWER Gt4xi 8-bit graphics subsystem 1-20
POWER GXT1000 graphics accelerator attachment adapter 1-29
POWER GXT150 graphics subsystem 1-31
power plug table, remote async node 1-97
power supply, remote async node 1-96
priority, SCSI address 4-6

R

RAN 1-89
RAN, EIA-232 enhanced 1-88
RAN, EIA-232 original 1-88
RAN, RS-422 enhanced 1-88
Re-IPL cable RA 5-44
Re-IPL cable RB 5-45
Re-IPL cabling 3-71
 serial to Re-IPL port Re-IPL cable 3-71
 serial to serial port Re-IPL cable 3-71
Re-IPL cabling, Serial to Re-IPL Port 3-71
Re-IPL cabling, Serial to Serial Port 3-71
realtime interface co-processor multiport/2 adapter/A
 4-Port EIA-232-C 3-15
 4-Port EIA-232-C/4-Port EIA-422A 3-16
 6-Port Synchronous EIA-232-C 3-15
 8-Port EIA-232-C 3-16
 8-Port EIA-422-A 3-16
realtime interface co-processor portmaster adapter/A
 6-Port X.21 3-19
 8-Port EIA-232-D 3-18
 8-Port EIA-422-A 3-18
receive card (HIPPI) channel attachment adapter 1-159
reference list, IHV supplied adapters 1-3
remote async node 3-9
remote async node 16-port EIA-232 1-88, 1-89
remote async node cabling 3-8
remote async node EIA-232, connectors 1-94
remote async node FC (8130) 1-88
remote async node FC (8137) 1-88
remote async node FC (8138) 1-88
remote async node front panel 1-91
remote async node rack style FC (8136) 1-89
remote async node, power supply 1-96
remote async node, programming 1-92
remote async node, RS-422 connectors 1-95
removing tape cartridge
 12.0GB 4-mm tape drive, manually remove 2-26
 2.0G-byte 4-mm tape drive 2-15
 2.3G-byte 8-mm tape drive 2-30
 20GB 8-mm tape drive 2-45

removing tape cartridge (*continued*)
4-mm tape drive 2-20
5G-byte 8-mm tape drive 2-40

S

S/370 channel emulator/A 1-132
S/370 host interface adapter 1-136
SCSI address priority 4-6
SCSI addresses
1.37G-byte SCSI disk drive 2-88
1080MB SCSI disk drives 2-72
12.0GB 4-mm tape drive internal installation 2-26
160MB SCSI disk drive 2-46
1G SCSI disk drives 2-69
2.0G-byte 4-mm tape drive 2-14
2.0G-byte SCSI-2 disk drive 2-91
2.3G-byte 8-mm tape drive 2-30
2.4G-byte SCSI disk drive 2-1, 2-94
20.0 GB 8-mm tape drive internal installation 2-43
200MB SCSI disk drive 2-47
320MB and 400MB SCSI disk drive 2-48
355MB and 670MB SCSI disk drive 2-49
4.0 GB 4-mm tape drive external 2-17
4.0GB 4-mm tape drive internal installation 2-18
5.0 GB 8-mm tape drive external 2-39
5.0 GB 8-mm tape drive internal 2-40
540MB SCSI disk drive 2-51
857MB SCSI disk drive 2-52
857MB slim-high SCSI disk drive 2-53
CD-ROM 2-4
CD-ROM type a, switch settings 2-4
CD-ROM type b, jumper settings 2-5
CD-ROM type c, jumper settings 2-6
internal 1/4-inch cartridge tape drive 2-12
internal 1/4-inch cartridge tape drive 1.2G-byte 2-13
internal 1/4-inch cartridge tape drive
150M-byte 2-13
internal 1/4-inch cartridge tape drive
525M-byte 2-13
SCSI bus length 4-5
SCSI cabling 4-1
SCSI device address 4-6
SCSI devices external 4-4, 4-5
SCSI devices, cabling 4-3
SCSI differential high-performance internal/external I/O
controller 1-100
SCSI ID 4-6
SCSI single-ended high-performance internal/external
I/O controller 1-98
SCSI terminators 4-1, 4-5
SCSI-2 differential fast/wide adapter/A 1-106
SCSI-2 fast/wide adapter/A 1-110
SCSI-2 single-ended high-performance internal/external
I/O controller 1-103

serial to Re-IPL port, Re-IPL cable RA 5-44
serial to serial port Re-IPL cable 5-45
setting the SCSI address, cartridge tape drives,
1/4-inch 2-12
Setting the Terminator Resistor 2-2
speaker 3-72
speaker and keyboard, attach 3-72
SSA 4-Port Adapter (type 4-D)
description 1-118
lights 1-119
SSA 4-Port Adapter, enhanced (type 4-G)
description 1-120
lights 1-121
SSA 4-Port RAID Adapter (type 4-I)
description 1-122
lights 1-123
SSA cables for 7131 3-64
SSA cables for 7133 3-63
SSA cabling for adapter FCs 6214, 6216, 6217, and
6219 3-61
SSA fast-write cache option card 1-124
standard I/O ports 3-69

T

terminator power (TERMPWR) 4-7
terminators, SCSI 4-1, 4-5
token-ring high-performance network adapter 1-39
transmit card (HIPPI) channel attachment
adapter 1-159
TURBOWAYS 100 ATM adapter 1-166
TURBOWAYS 155 ATM adapter 1-181
type A tape drive SCSI addresses 2-18
type A1 disk drive, SCSI addresses 2-77
type A2 disk drive, SCSI addresses 2-78
type A3 disk drive, SCSI addresses 2-78
type A4 8-bit disk drive, SCSI addresses 2-79
type A4 disk drive, SCSI addresses 2-79
type B tape drive SCSI addresses 2-19
type B1 disk drive, SCSI addresses 2-80
type B2 disk drive, SCSI addresses 2-80
type B3 disk drive, SCSI addresses 2-81
type C1 disk drive, SCSI addresses 2-81
type C2 disk drive, SCSI addresses 2-82
type C3 disk drive, SCSI addresses 2-82
type C4 disk drive, SCSI addresses 2-83
type C5 8-bit disk drive, SCSI addresses 2-84
type C5, a C2 used as an 8-bit disk drive, SCSI
addresses 2-84
type D1 16 bit disk drive, SCSI addresses 2-85
type D1 16-bit disk drive, SCSI addresses 2-86
type D2 16-bit disk drive, SCSI addresses 2-85
type D3 8-bit disk drive, SCSI addresses 2-86
type D3, a D1 used as an 8-bit disk drive, SCSI
addresses 2-86

type E1 disk drive, SCSI addresses 2-87
type number, adapter identification cross-reference
list 1-4

U

ultimedia audio adapter 1-154
ultimedia video I/O adapter 1-151

X

X.25 interface co-processor/2 1-43

Reader's Comments — We'd Like to Hear From You

RS/6000 Adapters, Devices, and Cable Information for Micro Channel Bus Systems

Part Number: SA38-0533-03

Overall how satisfied are you with the information in this book?

	Very Satisfied	Satisfied	Neutral	Dissatisfied	Very Dissatisfied
Overall Satisfaction	<input type="checkbox"/>	<input type="checkbox"/>	<input type="checkbox"/>	<input type="checkbox"/>	<input type="checkbox"/>

How satisfied are you that the information in this book is:

	Very Satisfied	Satisfied	Neutral	Dissatisfied	Very Dissatisfied
Accurate	<input type="checkbox"/>	<input type="checkbox"/>	<input type="checkbox"/>	<input type="checkbox"/>	<input type="checkbox"/>
Complete	<input type="checkbox"/>	<input type="checkbox"/>	<input type="checkbox"/>	<input type="checkbox"/>	<input type="checkbox"/>
Easy to find	<input type="checkbox"/>	<input type="checkbox"/>	<input type="checkbox"/>	<input type="checkbox"/>	<input type="checkbox"/>
Easy to understand	<input type="checkbox"/>	<input type="checkbox"/>	<input type="checkbox"/>	<input type="checkbox"/>	<input type="checkbox"/>
Well organized	<input type="checkbox"/>	<input type="checkbox"/>	<input type="checkbox"/>	<input type="checkbox"/>	<input type="checkbox"/>
Applicable to your tasks	<input type="checkbox"/>	<input type="checkbox"/>	<input type="checkbox"/>	<input type="checkbox"/>	<input type="checkbox"/>

Please tell us how we can improve this book:

Thank you for your response. May we contact you? Yes No

When you send comments to us, you grant us a nonexclusive right to use or distribute your comments in any way we believe appropriate without incurring any obligation to you.

_____ Name	_____ Address
_____ Company or Organization	_____
_____ Phone Number	_____

Fold and Tape

Please do not Staple

Fold and Tape

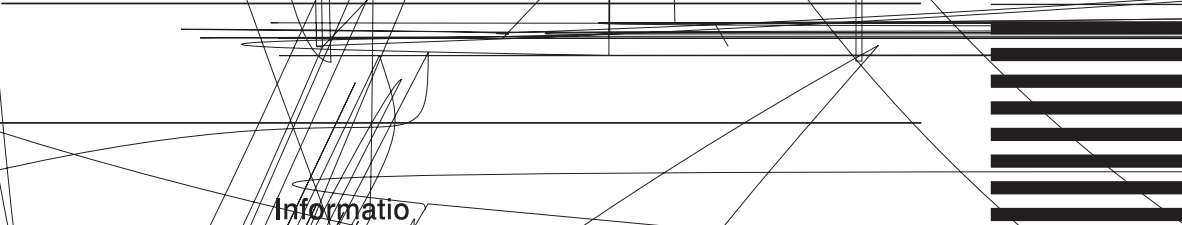

Informatio



Fold and Tape

Please do not Staple

Fold and Tape



Part Number: 07L9126



Printed in the United States of America
on recycled paper containing 10%
recovered post-consumer fiber.

SA38-0533-03



07L9126



Spine information:



RS/6000

**Adapters, Devices, and Cable Information
for Micro Channel Bus Systems**