

82C481

T-52-33-45

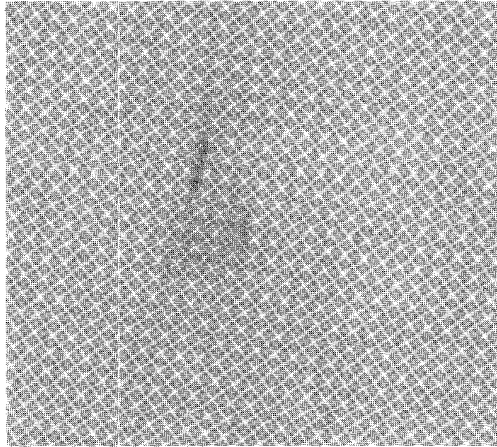
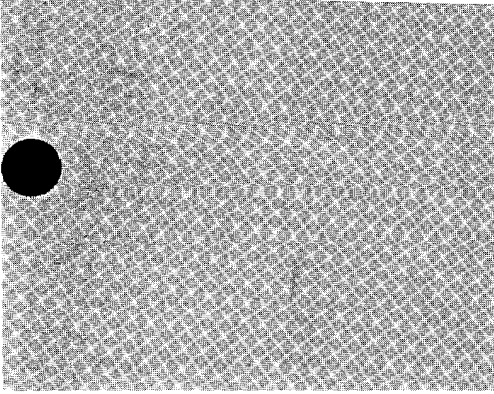

True Color
Graphics Accelerator

Advance Product Information

March 1992

ADVANCE
PRODUCT
INFORMATION

P R E L I M I N A R Y

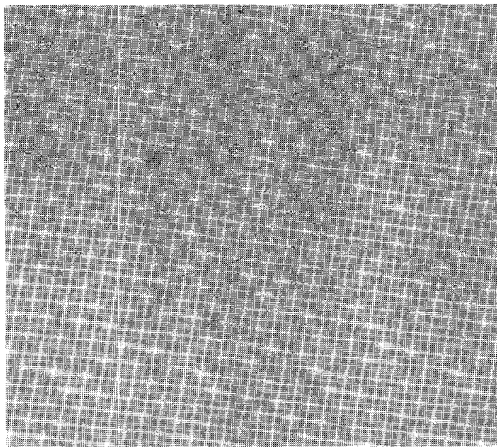

CHIPS®

A

9000-3806

Copyright Notice

Copyright © 1991, 1992 Chips and Technologies, Inc. ALL RIGHTS RESERVED.

This manual is copyrighted by Chips and Technologies, Inc. You may not reproduce, transmit, transcribe, store in a retrieval system, or translate into any language or computer language, in any form or by any means, electronic, mechanical, magnetic, optical, chemical, manual, or otherwise, any part of this publication without the express written permission of Chips and Technologies, Inc.

Restricted Rights Legend

Use, duplication, or disclosure by the Government is subject to restrictions set forth in subparagraph (c)(1)(ii) of the Rights in Technical Data and Computer Software clause at 252.277-7013.

Trademark Acknowledgement

CHIPS and NEAT are registered trademarks of Chips and Technologies, Inc. CHIPS, CHIPS_{Set}, MICROCHIPS, SCAT, NEAT_{sx}, LeAP_{Set}, LeAP_{Set}_{sx}, PEAK, CHIPS/230, CHIPS/250, CHIPS/280, CHIPS/450, CHIPSPak, CHIPSPort, CHIPSlink, and SMARTMAP are trademarks of Chips and Technologies, Incorporated.

IBM AT, XT, PS/2, Micro Channel, Personal System/2, Enhanced Graphics Adapter, Color Graphics Adapter, Video Graphics Adapter, IBM Color Display, and IBM Monochrome Display are trademarks of International Business Machines.

Hercules is a trademark of Hercules Computer Technology.

MS-DOS is a trademark of Microsoft, Incorporated.

MultiSync is a trademark of Nippon Electric Company (NEC).

Brooktree and RAMDAC are trademarks of Brooktree Corporation.

Inmos is a trademark of Inmos Corporation.

Tri-State is a trademark of National Semiconductor Corporation.

Disclaimer

This document is provided for the general information of the customer. Chips and Technologies, Inc., reserves the right to modify the information contained herein as necessary and the customer should ensure that it has the most recent revision of the data sheet. CHIPS makes no warranty for the use of its products and bears no responsibility for any errors which may appear in this document. The customer should be on notice that the field of personal computers is the subject of many patents held by different parties. Customers should ensure that they take appropriate action so that their use of the products does not infringe upon any patents. It is the policy of Chips and Technologies, Inc. to respect the valid patent rights of third parties and not to infringe upon or assist others to infringe upon such rights.

B



82C481 True Color Graphics Accelerator

- Accelerates Windows environments and CAD applications
- Drawing engine support for 16, 24 and 32bpp operations
- Hardware Graphics Functions:
 - Bit Blt
 - Line Draw
 - Color Mixing
 - Polygon Fill
 - Pattern Fill
 - Scissoring
- Tightly coupled to the Brooktree Bt484/Bt485 RAMDACs™ and Texas Instruments TLC34075 Color Palette DAC
- Zero Wait State operation for system memory to screen memory BitBlts
- Integrated graphics accelerator solution requires only 6 standard TTL components plus VRAM to implement a 1M video subsystem
- Pin compatible with the 82C480 graphics accelerator providing an easy upgrade path
- Software transparent non-interlaced monitor support

- Support for 1M VRAMs at a wide variety of resolutions and color depths:

256Kx4 VRAM	1M	2M	4M
512x512x32bpp	✓	✓	✓
640x480x16bpp	✓	✓	✓
640x480x32bpp	✓	✓	✓
1024x768x8bpp	✓	✓	✓
1024x768x16bpp	✓	✓	✓
1024x768x24bpp	✓	✓	✓
1280x1024x4bpp	✓	✓	✓
1280x1024x8bpp	✓	✓	✓
1280x1024x16bpp	✓	✓	✓

- Resolutions supported up to 2048x2048x8bpp (either interlaced or non-interlaced) with video rates up to 400 MHz
- Single Chip Solution: 160-Pin Plastic Flatpack
- Fully Backwards Compatible with IBM® 8514/A at register level
- Low-Power CMOS process

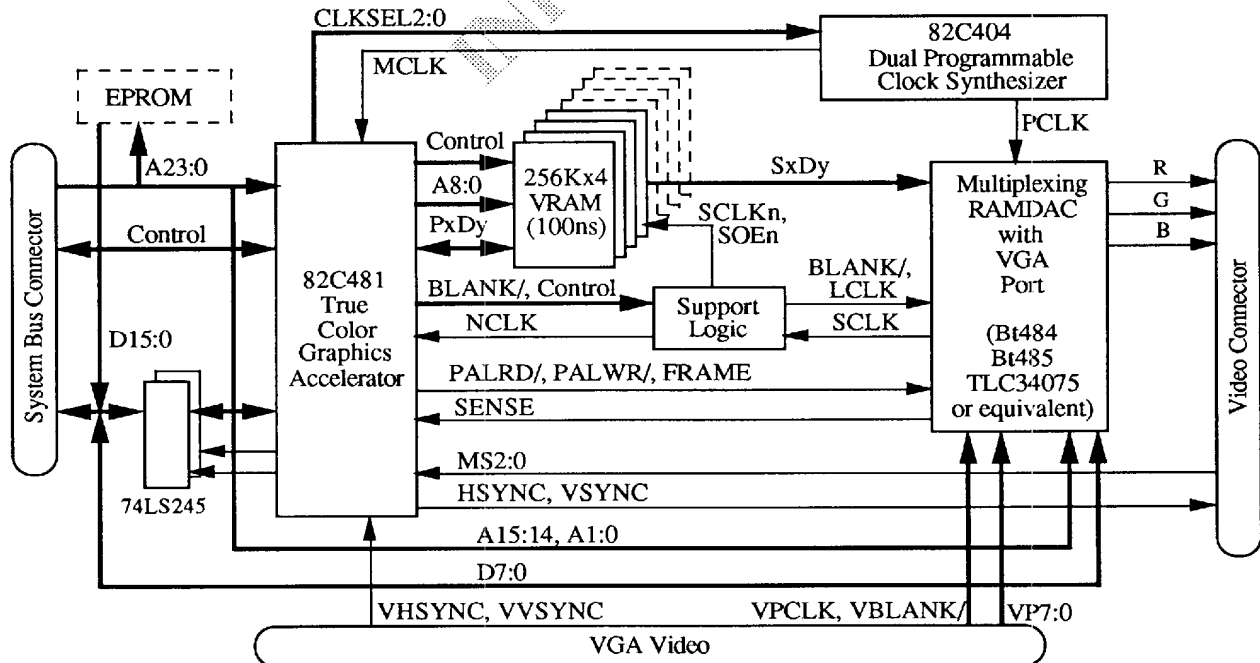

82C481 System Block Diagram



T-52-33-45

Revision History

<u>Revision</u>	<u>Date</u>	<u>By</u>	<u>Comment</u>
0.1	10/02/91	DR	Initial review copy
0.2	1/16/92	DR	Updated to include UISA interface
0.3	2/26/92	DR	Added timing information

ADVANCE
PRODUCT
INFORMATION



Table of Contents

<u>Section</u>	<u>Page</u>	<u>Section</u>	<u>Page</u>
Introduction	5	Pixel Operations	87
Bit-Block Transfer (BITBLT).....	6	Mixes.....	87
Line Draw	6	Source Operand Selection	87
VRAM Interface	6	Foreground and Background	87
Performance	6	Foreground Select Mode	89
Video Subsystem Total Chip Count	6	Color Comparison.....	91
Bus Interface	7	Plane Masks.....	91
External Color Palette	7	Across Planes vs. Through Planes	92
ROM Interface	7	Scratch Register	92
Extension Registers	7	Drawing Operations.....	95
Monitor Support	7	Line.....	95
Text and Alphanumeric Support	7	SSV Drawing	95
Package	7	Rectangle	96
82C481 System Diagrams.....	8	Copy Rectangle	97
Pinouts.....	9	Fast Rectangle	97
Pin Diagram	9	X Rectangle	97
Pin List	10	Y Rectangle	98
Pin Descriptions - System Bus Interface.....	11	Polygon Fill	98
Pin Descriptions - Display Memory.....	17	Text Modes.....	98
Pin Descriptions - Clocks.....	19	Application Schematic Examples.....	99
Pin Descriptions - Video Interface.....	20	Introduction	99
Pin Descriptions - Test, Power & Ground.....	22	ISA Bus Circuit Example.....	101
Register and Port Address Summaries.....	23	PC/AT Bus Circuit Example	102
Register Bit Summary	24	Micro Channel Bus Circuit Example.....	103
Functional Description.....	69	VRAM Memory Config. A (82C480).....	104
System Interface	69	VRAM Memory Config. A (NIBBLE).....	105
Micro Channel Interface	70	VRAM Memory Configuration B.....	106
ISA Interface	70	Video Circuit (IMSG176/178) Color Palette.....	107
UISA Interface.....	70	Video Circuit (BT471/478) Color Palette.....	108
EISA Interface	70	Video Circuit (BT484/485).....	109
Queue	70	Electrical Specifications.....	111
Interrupts	71	Absolute Maximum Conditions.....	111
Memory Interface.....	73	Operating Conditions	111
Memory Architecture.....	73	DC Characteristics.....	111
Memory Configurations	74	AC Characteristics.....	112
RAM Cycle Types.....	74	Nugget Clock Timing	112
Video Interface.....	77	Reset Timing	112
Horizontal Timing.....	77	ISA Bus Timing	113
Vertical Timing	78	MC Bus Timing	120
Refresh Counter	79	VRAM Timing	123
Serial Bus	80	Switching Characteristics.....	123
Alternate Video Registers.....	80	Timing Requirements	123
Initialization/Configuration.....	83	Video Timing	132
Reset	83	Video Register Parameters	133
POS Operation	83	Mechanical Specifications.....	135
Configuration Options	83		



List of Figures and Tables

<u>Figure</u>	<u>Page</u>	<u>Table</u>	<u>Page</u>
System Diagram	1	VRAM 256K Resolution Support.....	6
VGA/8514 Pass-Through Interface	5	Relative Performance	6
82C481 Pinouts	9	Minimum Video Subsystem Chip Count	6
Video Timing Signals.....	78	82C481 Pin Usage	7
Mix Select	88	82C481 Pin List	10
Pixel Drawing Engine	90	16-bit Byte Steering	12
Bresenham Algorithm Implementation.....	96	Bus Cycle Type	14
ISA Bus Circuit Example.....	101	Monitor ID Type	16
PC/(UISA) Bus Circuit Example.....	102	MCLK Frequency vs. VRAM Speed	19
Micro Channel Bus Circuit Example.....	103	82C481 Registers	23
VRAM Memory Config. A (82C480)	104	Bit Summary	24
VRAM Memory Config. A (NIBBLE)	105	Horizontal Sync Polarities	29
VRAM Memory Configuration B	106	Vertical Sync Polarities	30
Video Circuit - IMSG176/178 Color Palette.....	107	IBM 8514/A Standard ROM Address Map..	31
Video Circuit - BT471/478 Color Palette.....	108	Data Path in 8:1 4 bpp Mode	41
Video Circuit - BT484/485 Color Palette.....	109	MC IBM 8514/A vs. 480 ROM Map.....	43
82C481 + 64200 Wingine Block Diagram	110	VGA ROM Map	43
82C481 + 64200 Wingine PCB Layout.....	110	Background Mix Selection	58
Nugget Clock Timing	112	Foreground Mix Selection.....	59
ISA/UISA 8-bit I/O Cycle Timing.....	114	Bus Signal Connections	69
ISA/USIA Bus Palette I/O Cycle Timing.....	115	Memory Configurations & Resolutions	74
ISA/UISA Bus 16-bit I/O Cycle Timing.....	116	Sync Polarities vs. Resolution.....	77
ISA Bus ROM Memory Cycle Timing.....	117	Scan Modulus	79
UISA Bus ROM Memory Cycle Timing	117	Alternate Register Selects	81
USIA Bus ROM 16-bit Memory Cycle Timing.....	118	Alternate Register Enable.....	81
USIA Bus ROM Memory Cycle Timing	119	VRAM Interleave.....	84
MC Bus I/O Cycle Timing	121	ROM Base Address	85
MC Bus ROM Memory Cycle Timing.....	122	Mix Selection	87
VRAM Fast Page Read Cycle Timing	125	Color Compare Operation	91
VRAM Fast Page Write Cycle Timing	126	Fill Boundary Mask.....	92
VRAM Fast Page RMW Cycle Timing	127	Absolute Maximum Conditions.....	111
VRAM Color Register Set Cycle Timing.....	128	Normal Operating Conditions	111
VRAM Flash Write Cycle Timing.....	129	DC Characteristics	111
VRAM Data Transfer Cycle Timing.....	130	AC Characteristics - Nugget Clock Timing.....	112
VRAM Refresh Cycle Timing	131	AC Characteristics - Reset Timing	112
82C481 Video Timing	132	AC Characteristics - ISA Bus Timing	113
82C481 Mechanical Specifications.....	135	AC Characteristics - MC Bus Timing	120
82C481 PCB Pad Layout	135	AC Characteristics - VRAM Timing	123
		AC Characteristics - Video Timing.....	132
		Video Register Parameters	133

Introduction

The 82C481 True Color Graphics Accelerator provides optimum performance and support for 16, 24, and 32 bit per pixel (bpp) modes in Windows environments and CAD applications. The 82C481 provides memory interface logic, video control logic, and interface logic to the ISA (PC/AT™) Bus, EISA Bus, and Micro Channel (MC).

The 82C481 has a dedicated hardware drawing engine which supports a wide range of pixel color depths. The drawing engine is optimized to accelerate functions most commonly used in a Windows environment at all color depths. This includes BitBlt, Rectangle and Line Drawing functions with Raster Ops. It also supports a variety of monochrome to color expansion schemes used for pattern fill and text generation. The 82C481 is designed for easy integration with high color RAMDACs.

The 82C481 can support a wide range of memory configurations. The minimum useful memory configuration is 512KBytes and the maximum is 4MBytes. The 82C481 drawing engine requires a

minimum of 1MByte to support 16, 24, and 32bpp modes.

The 82C481 supports the following modes selectable via software:

- VGA mode (pass through video from VGA subsystem)
- Graphics Accelerator or Advanced Function Mode (video from 82C481 frame buffer)

The 82C481 defaults to VGA mode on reset. In the Advanced Function mode, the 82C481 supports high resolutions and color depths. Custom software drivers enable accelerator hardware functions such as BitBlt, line drawing, polygon fill, patterns, raster operations, and scissoring (post-clipping).

Software support for the 82C481 is provided via Chips and Technologies supplied drivers for major software applications. All software which supports the IBM 8514/A will also support a compatible 82C481 implementation.

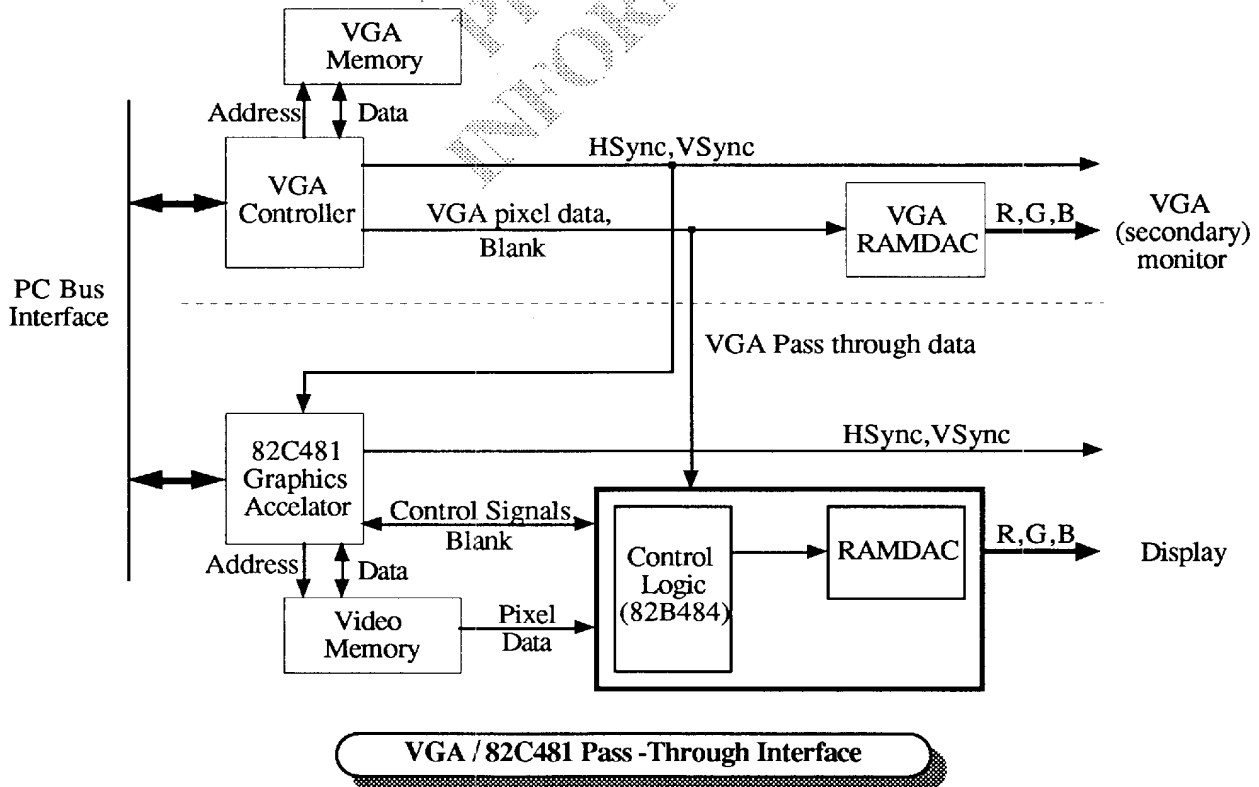



BIT-BLOCK TRANSFER (BITBLT)

The 82C481 uses an internal 320 bit register file for BitBlts (8 words x 32/40 bits). This allows reading a block of pixels in page mode, then writing it using page mode write or RMW cycles. The 82C481 has a 32/40-bit internal data path, and its fast clock rate results in optimum BitBlt performance. Bitblts can be performed on pixels up to 32-bits deep.

LINE DRAW

Line draw functions (straight lines only) are handled in hardware by the 82C481 chip. Arcs, circles, and other higher-level shapes must be decomposed to a series of short straight-line segments. The 82C481 uses the Bresenham algorithm for drawing arbitrary line segments. For vector drawing along a 45° axis, two faster line drawing mechanisms are supported. Short lines (of length 16 or less) can be generated in a pen-plotter format, two strokes per command. Long lines require four commands per stroke. Line drawing is supported at all pixel depths.

VRAM INTERFACE

The 82C481 supports (256Kx4) and (256Kx8) VRAMs allowing a low cost, low chip-count implementation. The 82C481 can also perform Flash Write cycles if the VRAMs support this feature. The 82C481 supports a fast memory clock (up to 50 MHz) to maximize use of VRAM bandwidth.

The 82C481 supports seven memory cycle types:

1. Read (page mode)
2. Write (page mode)
3. Read-Modify-Write (page mode)
4. RAS-only refresh
5. Data Transfer Cycle
6. Color Register Set Cycle (optional)
7. Flash Write Cycle (optional)

PERFORMANCE

The 82C481 provides up to 2 times the performance of the IBM XGA hardware at standard resolutions and color depths. Projected performance for major graphics operations are listed below (MB/s = million bytes per second):

Function	82C481	IBM XGA	Relative Performance
Clear (Flash) Horizontal	0.5 ms	30 ms	60x
Solid Line	24.0 MB/s	8 MB/s	3x
Rectangle Fill	4.2 MB/s	2.4 MB/s	1.75x
BitBlt	18.0 MB/s	9.0 MB/s	2x

VIDEO SUBSYSTEM TOTAL CHIP COUNT

Using the 82C481, a complete 16-bit video accelerator subsystem can be built with just 9 ICs including display memory, as shown in the table below:

Qty	Chip Type
1	82C481 True Color Graphics Accelerator
2	74LS245 Transceivers
1	Bt475 RAMDAC™
4	256Kx4 VRAM (+4 for 8 planes)
1	82B484 Support Chip
9	Total

Additional components required would be the 82C404 Programmable Clock Synthesizer, 15-pin video connector, and various resistors and capacitors. The indicated configuration (4 256K x 4 VRAM's) supports 640x480 non-interlaced 16-color and 256-color modes, and 1024x768 interlaced (44.900 MHz.) and non-interlaced (75.000 MHz.) 16-color mode.

Adding 256-color support for 1024x768 would require four additional 256Kx4 VRAM chips (for a total of 8 256K x 4 VRAM's). This would also support 1280x1024 16-color mode if the appropriate RAMDAC is used.

For high resolution/true color support, a high performance RAMDAC™ can be used. The parts count varies with implementation but a typical list is shown below:

Qty	Chip Type
1	82C481 True Color Graphics Accelerator
2	74LS245 Transceivers
1	Bt484 RAMDAC™ or TLC34075 Palette DAC
8	256Kx4 VRAM (16 for 2MByte depth)
6	Standard 74F and 74LS TTL devices
18	Total



Additional components required would be the 82C404 Programmable Clock Synthesizer, 15-pin video connector, and various resistors and capacitors. The indicated configuration (8 256K x 4 VRAM's) supports 512 x 512 x 32bpp, 640 x 480 x 16bpp, 1024 x 768 x 8bpp and 1280 x 1024 x 4bpp all at non-interlaced frequencies. If 2MBytes (16 256Kx4 VRAMs) are implemented, the resolutions supported are 1280 x 1024 x 8bpp, 1024 x 768 x 16bpp, and 640 x 480 x 32bpp.

If a 'Power-On-Self-Test' (POST) ROM is implemented in a Micro Channel bus configuration, two additional 8-bit address latches (74LS373 or equivalent) are required.

BUS INTERFACE

The 82C481 allows selection of either EISA/ISA (PC/AT), UISA (PC/AT), or MC (Micro Channel) Bus Interface by detecting strapping options during reset. All control signals for both interface types are integrated on chip.

The 82C481 supports both 8-bit and 16-bit CPU interfaces.

EXTERNAL COLOR PALETTE

The 82C481 supports the programming of an external color palette DAC (RAMDAC) by decoding the CPU addresses and generating the read and write signals for the external palette.

Normally, each RAMDAC analog output provides 6-bit resolution (64 shades of color on each of the analog R, G, and B outputs). However, one of several general purpose output pins provided by the 82C481 may be used for selecting 8-bit-per-color mode for the DAC.

ROM INTERFACE

The 82C481 supports an optional 8-bit ROM for Power-On-Self-Test (POST) code which may be implemented in AT-bus systems without using additional external components except the ROM chip. The ROM address is decoded and the ROMCS/ pin is asserted to enable ROM data onto the data bus. A 16-bit ROM may be implemented with two ROM chips and one additional external PAL.

Video initialization code and support functions may be included in the POST ROM, incorporated into the system BIOS, loaded from disk at system initialization as a TSR, or incorporated directly into drivers.

EXTENSIONS AND EXTENDED REGISTERS

The 82C481 chip provides advanced modes of operation. These advanced features are controlled via bits in extension registers.

The 82C481 registers are virtually all readable. This improves the testability of the chip and simplifies state saving.

MONITOR SUPPORT

The 82C481 supports the following analog monitors:

- IBM Monochrome Display 8503 or compatible
- IBM High Resolution Monochrome Display 8507 or compatible
- IBM Color Display 8512 or compatible
- IBM Color Display 8513 or compatible
- Interlaced monitors supporting high resolution (IBM 8514, 8515, or compatible)
- Multisync and compatible monitors
- Any interlaced or non-interlaced monitor with a resolution of up to 2560x2048 and supporting video rates of up to 400 MHz

TEXT AND ALPHANUMERIC SUPPORT

The 82C481 chip does not support a separate text mode in hardware. Text display is supported via graphics modes, so text may be any size.

PACKAGE

The 82C481 is available in a 160-pin plastic flat pack (PFP).

Complete descriptions of all 82C481 pins are included in this document starting on the next page. The pins are separated into the following logical groups for discussion: Bus Interface, Display memory, Video, Clock, Power, and Ground.

82C481 Pin Usage Summary

Bus Interface:	55
Display Memory:	62
Control/Status:	16
Video:	4
Clock:	2
Power:	7
Ground:	14

Total: 160



T-52-33-45

82C481 SYSTEM DIAGRAMS

Included at the end of this document are schematic examples of the following:

1. 8/16-bit ISA (PC/AT) Bus Interface
16-bit Micro Channel (MC) Bus Interface
2. Memory Interfacing (40-bit Configuration A)
Memory Interfacing (80-bit Configuration B)
3. Video/Clock Logic (82B484 - BT475/477)
Video/Clock Logic (82B484 - BT475/477)
Video/Clock Logic (BT484)
Video/Clock Logic (TLC34075)

ADVANCE
PRODUCT
INFORMATION



T-52-33-45

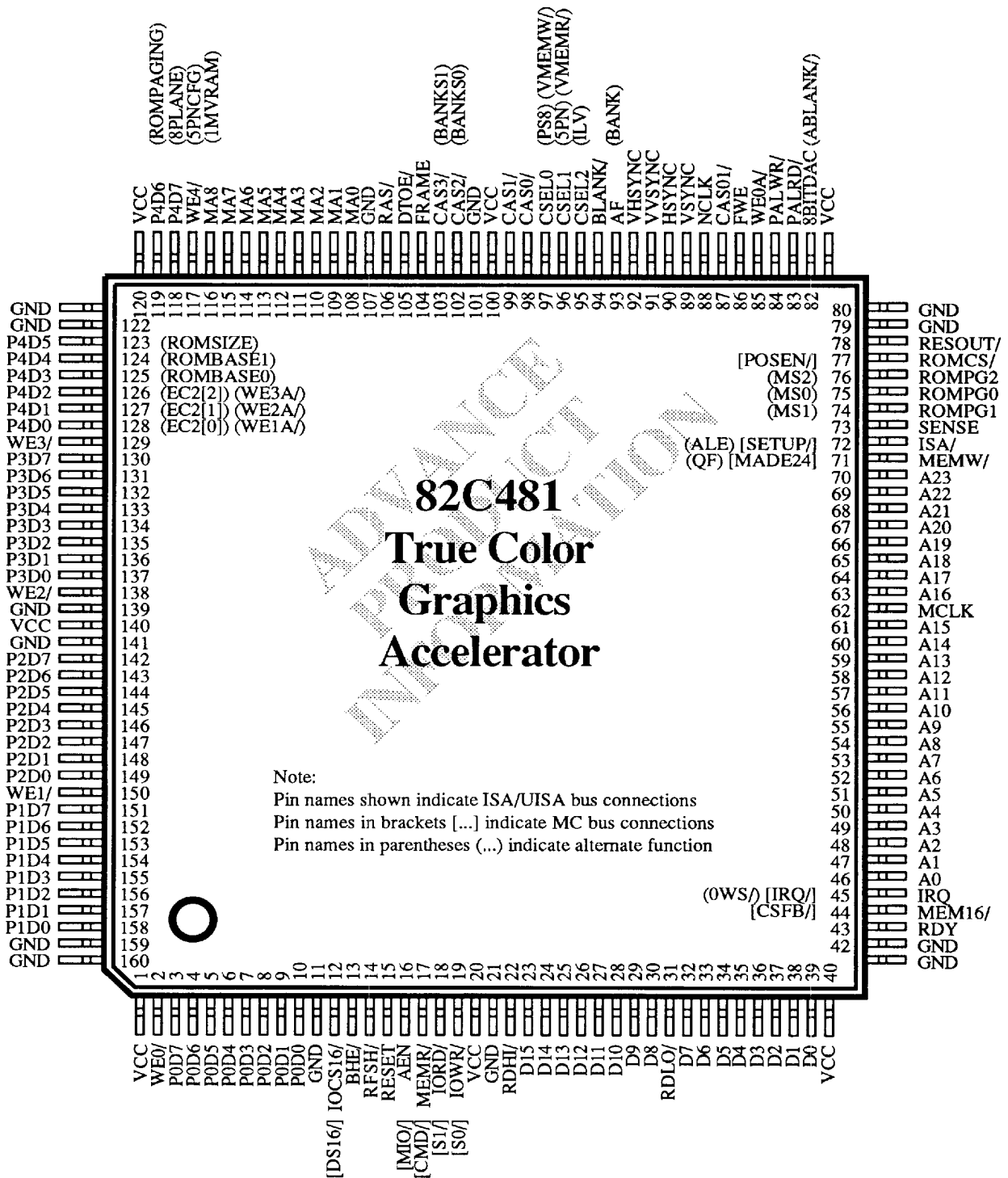



Pin List

T-52-33-45

Pin Name	Pin #	Pin Name	Pin #	Pin Name	Pin #
AEN	16	GND	42	P2D5	144
AF	93	GND	79	P2D6	143
A0	46	GND	80	P2D7	142
A1	47	GND	101	P3D0	137
A2	48	GND	107	P3D1	136
A3	49	GND	121	P3D2	135
A4	50	GND	122	P3D3	134
A5	51	GND	139	P3D4	133
A6	52	GND	141	P3D5	132
A7	53	GND	159	P3D6	131
A8	54	GND	160	P3D7	130
A9	55	FRAME	104	P4D0	128
A10	56	FWE	86	P4D1	127
A11	57			P4D2	126
A12	58	HYSNC	90	P4D3	125
A13	59	IOCS16/	12	P4D4	124
A14	60	IORD/	18	P4D5	123
A15	61	IOWR/	19	P4D6	119
A16	63	IRQ	45	P4D7	118
A17	64	ISA/	72	RAS/	106
A18	65	MA0	108	RDHI/	22
A19	66	MA1	109	RDLO/	31
A20	67	MA2	110	RDY	43
A21	68	MA3	111	RESET	15
A22	69	MA4	112	RESOUT/	78
A23	70	MA5	113	RFSH/	14
BHE/	13	MA6	114	ROMCS/	77
BLANK/	94	MA7	115	ROMPG0	75
CAS0/	98	MA8	116	ROMPG1	74
CAS01/	87	MCLK	62	ROMPG2	76
CAS1/	99	MEMR/	17	SENSE	73
CAS2/	102	MEMW/	71	VCC	1
CAS3/	103	MEM16/	44	VCC	20
CSEL0	97	NCLK	88	VCC	40
CSEL1	96	PALRD/	83	VCC	81
CSEL2	95	PALWR/	84	VCC	89
DTOE/	105	P0D0	10	VCC	100
D0	39	P0D1	9	VCC	120
D1	38	P0D2	8	VCC	140
D2	37	P0D3	7	VHSYNC	92
D3	36	P0D4	6	VSYNC	89
D4	35	P0D5	5	VVSYNC	91
D5	34	P0D6	4	WE0/	2
D6	33	P0D7	3	WE0A/	85
D7	32	P1D0	158	WE1/	150
D8	30	P1D1	157	WE1A/	128
D9	29	P1D2	156	WE2/	138
D10	28	P1D3	155	WE2A/	127
D11	27	P1D4	154	WE3/	129
D12	26	P1D5	153	WE3A/	126
D13	25	P1D6	152	WE4/	117
D14	24	P1D7	151	8BITDAC	82
D15	23	P2D0	149		
GND	11	P2D1	148		
GND	21	P2D2	147		
GND	41	P2D3	146		
		P2D4	145		



PIN DESCRIPTIONS

System Bus Interface

T-52-33-45

Pin #	Pin Name	Type	Active	Description
23	D15	I/O	High	System Upper Data Bus
24	D14	I/O	High	
25	D13	I/O	High	All byte steering is done internally, so the 82C481 may
26	D12	I/O	High	be used without data transceivers in motherboard
27	D11	I/O	High	applications; 74LS245 or equivalent transceivers are
28	D10	I/O	High	recommended for adapter cards to meet the 24 mA drive
29	D9	I/O	High	requirement.
30	D8	I/O	High	
32	D7	I/O	High	System Lower Data Bus
33	D6	I/O	High	
34	D5	I/O	High	
35	D4	I/O	High	
36	D3	I/O	High	
37	D2	I/O	High	
38	D1	I/O	High	
39	D0	I/O	High	
70	A23	In	High	System Address Bus. Latched internally for the MC
69	A22	In	High	bus on the falling edge of CMD/. Gated internally using
68	A21	In	High	ALE for UISA designs. Transparent internally for ISA
67	A20	In	High	designs.
66	A19	In	High	
65	A18	In	High	In MC designs, connect A23:0 to A23:0. In ISA
64	A17	In	High	(PC/AT) Bus designs, connect A19:0 to SA19:0 and
63	A16	In	High	A23:20 to ground. In UISA designs, connect A16:0 to
61	A15	In	High	SA16:0, and A23:17 to LA23:17.
60	A14	In	High	
59	A13	In	High	In MC designs, A14:0 must be latched externally by
58	A12	In	High	ADL/ or CMD/ for the ROM. In ISA bus designs, the
57	A11	In	High	address inputs need not be latched.
56	A10	In	High	
55	A9	In	High	
54	A8	In	High	
53	A7	In	High	
52	A6	In	High	
51	A5	In	High	
50	A4	In	High	
49	A3	In	High	
48	A2	In	High	
47	A1	In	High	
46	A0	In	High	



PIN DESCRIPTIONS

System Bus Interface

Pin #	Pin Name	Type	Active	Description															
72	ISA/ [SETUP/] (ALE)	In	Both	<p>The state of this pin during reset, in combination with pin 95 (CSEL2) determines the bus configuration for the 82C481.</p> <table border="1"> <thead> <tr> <th>ISA/</th> <th>CSEL2</th> <th>Bus Type</th> </tr> </thead> <tbody> <tr> <td>0</td> <td>0</td> <td>Unlatched ISA (UISA)</td> </tr> <tr> <td>0</td> <td>1</td> <td>ISA (82C480 compatible)</td> </tr> <tr> <td>1</td> <td>0</td> <td>Unlatched ISA (UISA)</td> </tr> <tr> <td>1</td> <td>1</td> <td>MicroChannel (82C480 compatible)</td> </tr> </tbody> </table> <p>This pin may be tied to ground or RESOUT/ in ISA Bus configurations. In UISA bus configurations, this pin should be connected to BALE. The MC interface also drives this pin to select the 82C481 during POS (if latched low on reset, the POS registers at 100-102h are not accessible and all other registers are accessible).</p>	ISA/	CSEL2	Bus Type	0	0	Unlatched ISA (UISA)	0	1	ISA (82C480 compatible)	1	0	Unlatched ISA (UISA)	1	1	MicroChannel (82C480 compatible)
ISA/	CSEL2	Bus Type																	
0	0	Unlatched ISA (UISA)																	
0	1	ISA (82C480 compatible)																	
1	0	Unlatched ISA (UISA)																	
1	1	MicroChannel (82C480 compatible)																	
15	RESET	In	High	<p>RESET=1 resets the 82C481 and tristates all output pins except RESOUT/. Also puts internal counters in a known state for chip test.</p>															
78	RESOUT/	Tri-O	Low	<p>RESOUT/ is an inverted and delayed RESET. It is used to enable external tristate buffers required to drive programming options on the 82C481 pins; these options are latched on the falling edge of RESET. RESOUT/ is guaranteed to stay low long enough to meet the hold time requirement from RESET for any programming option. Some options, such as on the MA8 pin, may be driven by RESOUT/ directly.</p>															
13	BHE/	In	Low	<p>Byte High Enable. Low indicates that the high order byte at the current word address is being accessed. Along with A0, indicates which bytes are transferred over the bus (all byte steering is done internally):</p> <table border="1"> <thead> <tr> <th>BHE/</th> <th>A0</th> <th>Effect</th> </tr> </thead> <tbody> <tr> <td>0</td> <td>0</td> <td>Both bytes on D15:0 (16-bit slot only)</td> </tr> <tr> <td>0</td> <td>1</td> <td>High byte on D15:8 (16-bit slot only)</td> </tr> <tr> <td>1</td> <td>0</td> <td>Low byte on D7:0 (8- or 16-bit slot)</td> </tr> <tr> <td>1</td> <td>1</td> <td>High byte on D7:0 (8-bit slot only)</td> </tr> </tbody> </table> <p>The 82C481 configures itself to 8- or 16-bit slots. BHE/ is located on the 16-bit bus extension in PC/AT systems, so BHE/ has an internal pullup to hold it inactive in case the card is installed in an 8-bit slot.</p> <p>Note: Performance is greatly reduced when operating in an 8-bit ISA slot due to the length of 8-bit ISA bus cycles. The 82C481 will not function correctly in an 8-bit slot when a UISA bus interface is used.</p>	BHE/	A0	Effect	0	0	Both bytes on D15:0 (16-bit slot only)	0	1	High byte on D15:8 (16-bit slot only)	1	0	Low byte on D7:0 (8- or 16-bit slot)	1	1	High byte on D7:0 (8-bit slot only)
BHE/	A0	Effect																	
0	0	Both bytes on D15:0 (16-bit slot only)																	
0	1	High byte on D15:8 (16-bit slot only)																	
1	0	Low byte on D7:0 (8- or 16-bit slot)																	
1	1	High byte on D7:0 (8-bit slot only)																	



PIN DESCRIPTIONS

System Bus Interface

Pin #	Pin Name	Type	Active	Description
22 31	RDHI/ RDLO/	Tri-O Tri-O	Low Low	Direction control for high and low external data bus transceivers. These outputs are tristate when RESET is active. Internal pullups to prevent driving the bus. 0 = Read data from 82C481 1 = Write data into 82C481
71	MEMW/ [MADE24] [QF]	I/O	Both	For UISA designs as in all 82C480 ISA designs, this pin should be connected to MEMW/. For compatibility with 82C480 designs this pin is tristate after reset. In ISA (PC/AT) bus interface, this pin is actually unused and does not have to be connected. In UISA designs it indicates a memory write cycle. For ISA designs implementing a local display list processor, this pin can be used to indicate that the queue is full. To output the Queue Full status this pin must be enabled through an extended configuration register bit (EC1[8]). In MC interface, MADE24=1 indicates only 24 bits of address are being decoded; the 82C481 will not respond to any cycle in MC mode unless this pin is high. MADE24 may also be used as an active-high chip select to decode 32-bit addresses.
17	MEMR/ [CMD/]	In	Low	In MC, indicates a command cycle (valid data on the bus). It is driven by CMD/ from the MC bus. In ISA bus, indicates a memory read cycle. This signal is used to decode ROMCS/ accesses as well as PIX_TRANS accesses in UISA mode.



PIN DESCRIPTIONS

System Bus Interface

Pin #	Pin Name	Type	Active	Description																																				
19	IOWR/ [S0/]	In	Low	In ISA (PC/AT) bus interface, indicates an I/O Write cycle. In MC bus interfaces, indicates Status bit 0 (S0).																																				
18	IORD/ [S1/]	In	Low	In ISA (PC/AT) bus interface, indicates an I/O Read cycle. In MC bus interfaces, indicates Status bit 1 (S1).																																				
16	AEN [MIO/]	In	Both	In ISA (PC/AT) bus interface, defines valid I/O address: 0 = Valid I/O address, 1 = Invalid I/O address (DMA cycle). If single-cycle DMA is used, memory addresses will be on the bus at the same time that IORD/ or IOWR/ is active. The 82C481 will not respond to IORD/ or IOWR/ while AEN=1. In MC bus interface, indicates memory or I/O cycle: 1 = memory cycle, 0 = I/O cycle.																																				
				<table border="1"> <thead> <tr> <th>MIO/</th> <th>S1/</th> <th>S0/</th> <th>Cycle Type</th> </tr> </thead> <tbody> <tr> <td>0</td> <td>0</td> <td>0</td> <td>-reserved-</td> </tr> <tr> <td>0</td> <td>0</td> <td>1</td> <td>I/O Read</td> </tr> <tr> <td>0</td> <td>1</td> <td>0</td> <td>I/O Write</td> </tr> <tr> <td>0</td> <td>1</td> <td>1</td> <td>-reserved-</td> </tr> <tr> <td>1</td> <td>0</td> <td>0</td> <td>-reserved-</td> </tr> <tr> <td>1</td> <td>0</td> <td>1</td> <td>Memory Read</td> </tr> <tr> <td>1</td> <td>1</td> <td>0</td> <td>Memory Write</td> </tr> <tr> <td>1</td> <td>1</td> <td>1</td> <td>-reserved-</td> </tr> </tbody> </table>	MIO/	S1/	S0/	Cycle Type	0	0	0	-reserved-	0	0	1	I/O Read	0	1	0	I/O Write	0	1	1	-reserved-	1	0	0	-reserved-	1	0	1	Memory Read	1	1	0	Memory Write	1	1	1	-reserved-
MIO/	S1/	S0/	Cycle Type																																					
0	0	0	-reserved-																																					
0	0	1	I/O Read																																					
0	1	0	I/O Write																																					
0	1	1	-reserved-																																					
1	0	0	-reserved-																																					
1	0	1	Memory Read																																					
1	1	0	Memory Write																																					
1	1	1	-reserved-																																					
14	RFSH/	In	Low	Active low signal indicating Refresh cycle. When this pin is low, the chip is not accessible to memory cycles.																																				
43	RDY	Tri-O	High	Ready. Driven low to indicate that the current cycle should be extended with wait states. Driven high at the end of cycle to indicate 'ready', then tristated. This signal is normally tristated. It is driven low to insert the necessary wait states if the 82C481 cannot respond immediately to memory or I/O requests (eg. ROM memory cycles in MC). Another way to look at this pin is as an active-low wait-state request line, rather than as an active-high ready line. This signal remains tristated for all accesses to the VGA palette registers (03C6h-03C9h) even if EC1[15]=1. In that case it relies on the VGA in the system to generate 'ready'.																																				



PIN DESCRIPTIONS

System Bus Interface

Pin #	Pin Name	Type	Active	Description
44	MEM16/ [CSFB/]	Tri-O	Low	In ISA (PC/AT) bus configurations, this pin is currently unused. For future compatibility, this pin should be connected to MEMCS16/. In UISA bus configurations this pin indicates a 16-bit memory access. In MC bus configurations, this pin is called 'Card Select Feedback'; it indicates any valid access to the 82C481. It is an unlatched decode of A23:0, MIO/, and MADE24.
12	IOCS16/ [DS16/]	Tri-O	Low	In ISA (PC/AT) bus interface, indicates 16-bit I/O cycle. In MC Interface, indicates 16-bit Memory or I/O cycle. Asserted by the 82C481 to indicate that the chip is capable of transferring 16 bits over the bus at the requested address. In the MC bus, DS16/ is active for all 82C481 accesses except those to the RAMDAC, POS, and ROM.
45	IRQ [IRQ/] (0WS/)	Tri-O	Both	In the ISA (PC/AT) bus, this pin is tristated when interrupts are not enabled, low when interrupts are enabled but no interrupt is pending, and high when interrupts are enabled and an interrupt is pending. In the MC bus, this pin functions as an active-low open-collector output. The interrupt request pin is normally connected to IRQ9. IRQ9/ may be shared by multiple controllers on the MCA bus; in the ISA bus, only one controller at a time may have IRQ9 enabled. In the UISA bus, this pin functions the same as in ISA mode unless ZWS EC0[8]=1 indicating connection to 0WS/. When ZWS is enabled no interrupts are generated externally. Active low zero wait state cycle requests are generated for memory-mapped (EC0[2:0]) accesses to PIX_TRANS when the queue is not full (or when data is ready for PIX_TRANS MEMR/ cycles).
77	ROMCS/ [POSEN/]	I/O	Low	In ISA (PC/AT) bus configurations, this pin indicates access to ROM space. In MC configurations, this pin indicates access to ROM space or to the POS ID registers (I/O address 100-101h and SETUP/ active). In 82C481-based designs with ROM, the POS registers map into the ROM. In systems without ROM, the same information may be provided from external TTL drivers activated by A0 and POSEN/. Note: Since ROMCS/ is in input mode during reset, an internal pullup resistor ensures the ROM is held in a quiescent state.



PIN DESCRIPTIONS

Pin #	Pin Name	Type	Active	Description
76	ROMPG2 (MS2)	I/O	High	ROM Page (ROM Address msb) outputs / Monitor ID inputs. During reset, these pins are inputs sampled on the falling edge of RESET (these pins have internal 50K pullups) to latch the state of the Monitor ID inputs (MS2:0) from the video connector, which may then be read from the Subsystem Status register. If a ROM is connected to ROMPG2:0, MS2:0 are normally driven onto these pins with a tri-state buffer enabled by RESOUT/. However, if P4D6 is low at the falling edge of RESET, these pins remain inputs so MS2:0 may be connected to these pins directly. If P4D6 is high at the falling edge of RESET, these pins then become outputs driven by ROM_PAGE_SEL[2:0]. If ROM paging capability is desired, these pins connect to ROM address inputs A14:12 (32K) or A12:10 (8K).
74	ROMPG1 (MS1)	I/O	High	
75	ROMPG0 (MS0)	I/O	High	

MS2	MS1	MS0	Monitor Type
0	0	0	reserved
0	0	1	8507 (Mono) (31.5/35.5 KHz)
0	1	0	8514 (Color) (31.5/35.5 KHz)
0	1	1	reserved
1	0	0	reserved
1	0	1	8503 (Mono) (31.5 KHz)
1	1	0	8512/13 (Color) (31.5 KHz)
1	1	1	reserved

Note: The ROMPG2:0 outputs are forced high during SETUP mode, independent of the ROM Page register contents.

Note: ROM_PG_SEL [2:0] register bits are set to 1 on RESET, so that the ROM page defaults to ROM page 7.

Note: In MC systems, address bits A11:0 must be latched for the ROM. Addresses may be latched by 74LS373 or equivalent transparent latches on the falling edge of CMD/ or by 74LS374 or equivalent registers on the rising edge of ADL/. In ISA systems, ROM addresses A11:0 are held valid during the entire bus cycle and need not be latched.

Note: In MC systems, A1:0 may be connected directly to the RAMDAC. IMSG176 or equivalent RAMDACs latch their register select inputs internally on the leading edge of PALRD/ or PALWR/ and the MC bus holds addresses valid long enough to meet hold time requirements. If addresses are latched for a ROM however, use the latched address to minimize the bus signal fanout.



PIN DESCRIPTIONS

Display Memory Interface

Pin #	Pin Name	Type	Active	Description																				
118	P4D7 (8PLANE)	I/O	High	VRAM Data Bus. The first digit in the signal name indicates the position of the pixel within the 'nugget'. The second indicates the bit position ('plane') within the pixel. P4D2:0 also function as Alternate Write Enable signals WE3:1A/. In standard modes, these signals are the same as WE3:1/. If 8, 256Kx4 VRAMs are installed, the memory may be mapped as 2048x1024x4bpp by enabling the alternate WE signals. This nibble mode is enabled through Extended Configuration register EC1. The state of pin 104 on reset enables WEA3:0/ and CAS01/. The P4Dn pins are also used for hardware configuration options. On the falling edge of RESET, the state of the P4Dn pins are latched internally. These 8 bits contain internal pull-ups which cause the options to default to standard 8514/A compatible values. An external LS244 buffer (enabled by RESOUT/) may be used to drive non-default ('0') configuration values on any subset of the P4Dn pins. The inputs of the buffer may be strapped to ground or tied to jumpers for user-configurable options. Software may write over any configuration options latched from P4Dn which eliminates the need for most strapping options. P4D7 is saved at reset as a read-only bit in Subsystem Status register (42E8) bit-7 (SUBSYS_STAT[7]). It is also accessible (read/write) in Extended Configuration register 2 (5AE8h) bit-7 (EC2[7]). It is interpreted as the 8PLANE ('8 Bit Planes') bit: 0 4-Plane/16-color configuration 1 8-Plane/256-color configuration (default) P4D6 is saved in EC2[6] as ROM Paging: 0 ROMPG2:0 are input pins readable at SUBSYS_STAT[6:4] (Monitor Sense pins). 1 ROMPG2:0 output ROM_PAGE_SEL[2:0] (Monitor Sense bits are latched from ROMPG2:0 on the falling edge of RESET only) P4D5 is saved in EC2[5] as ROM Size: 0 = 32K, 1 = 8K ROM space P4D4:3 are saved in EC2[4:3] at reset. These are interpreted by hardware as ROMBase: <table border="1"> <tr> <th>P4 Bit 4:3</th> <th>8K MCA</th> <th>8K ISA</th> <th>32K</th> </tr> <tr> <td>00</td> <td>C8000h</td> <td>C6000h</td> <td>D0000h</td> </tr> <tr> <td>01</td> <td>D8000h</td> <td>D8000h</td> <td>D8000h</td> </tr> <tr> <td>10</td> <td>C0000h</td> <td>C0000h</td> <td>C0000h</td> </tr> <tr> <td>11 (default)</td> <td>C6000h</td> <td>C8000h</td> <td>C8000h</td> </tr> </table>	P4 Bit 4:3	8K MCA	8K ISA	32K	00	C8000h	C6000h	D0000h	01	D8000h	D8000h	D8000h	10	C0000h	C0000h	C0000h	11 (default)	C6000h	C8000h	C8000h
P4 Bit 4:3	8K MCA	8K ISA	32K																					
00	C8000h	C6000h	D0000h																					
01	D8000h	D8000h	D8000h																					
10	C0000h	C0000h	C0000h																					
11 (default)	C6000h	C8000h	C8000h																					
119	P4D6 (ROMPAGING)	I/O	High																					
123	P4D5 (ROMSIZE)	I/O	High																					
124	P4D4 (ROMBASE1)	I/O	High																					
125	P4D3 (ROMBASE0)	I/O	High																					
126	P4D2 (reserved) (WE3A/)	I/O	High																					
127	P4D1 (reserved) (WE2A/)	I/O	High																					
128	P4D0 (reserved) (WE1A/)	I/O	High																					
130	P3D7	I/O	High																					
131	P3D6	I/O	High																					
132	P3D5	I/O	High																					
133	P3D4	I/O	High																					
134	P3D3	I/O	High																					
135	P3D2	I/O	High																					
136	P3D1	I/O	High																					
137	P3D0	I/O	High																					
142	P2D7	I/O	High																					
143	P2D6	I/O	High																					
144	P2D5	I/O	High																					
145	P2D4	I/O	High																					
146	P2D3	I/O	High																					
147	P2D2	I/O	High																					
148	P2D1	I/O	High																					
149	P2D0	I/O	High																					
151	P1D7	I/O	High																					
152	P1D6	I/O	High																					
153	P1D5	I/O	High																					
154	P1D4	I/O	High																					
155	P1D3	I/O	High																					
156	P1D2	I/O	High																					
157	P1D1	I/O	High																					
158	P1D0	I/O	High																					
3	P0D7	I/O	High																					
4	P0D6	I/O	High																					
5	P0D5	I/O	High																					
6	P0D4	I/O	High																					
7	P0D3	I/O	High																					
8	P0D2	I/O	High																					
9	P0D1	I/O	High																					
10	P0D0	I/O	High																					



PIN DESCRIPTIONS

Display Memory Interface

Pin #	Pin Name	Type	Active	Description	
116	MA8	(1MVRAM)	I/O	High	VRAM Address. On the falling edge of RESET, the state of MA8 is latched into extension register EC2[10]. If EC2[10] = 0, 256Kb VRAMs are being used (same as the IBM 8514/A); if EC2[10] = 1, 1Mb VRAMs are being used, and the 82C481 reinterprets VRTCFCG register bits to maintain register compatibility with the 8514/A. MA8 (only) has an internal 50K pull-up resistor, so the default is 1. To select 256K VRAMs, drive MA8 with RESOUT/.
115	MA7		Tri-O	High	
114	MA6		Tri-O	High	
113	MA5		Tri-O	High	
112	MA4		Tri-O	High	
111	MA3		Tri-O	High	
110	MA2		Tri-O	High	
109	MA1		Tri-O	High	
108	MA0		Tri-O	High	
106	RAS/		Tri-O	Low	VRAM Row Address Strobe. An internal pullup keeps the VRAMs in a quiescent state during reset. During normal operation, RAS/ will be observed active (low) except when a RAS precharge cycle is necessary.
103	CAS3/	(BANKS1)	I/O	Low	VRAM Column Address Strobes for memory banks 0-3. CAS3:1/ are unused in single-bank configurations (such as the basic four 1M-VRAM minimum configuration). CAS3:2/ have internal pullups and are sampled at reset and saved in EC2[9:8] as the number of VRAM banks installed: 00=1, 01=2, and 11=4 banks.
102	CAS2/	(BANKS0)	I/O	Low	
99	CAS1/		Tri-O	Low	
98	CAS0/		Tri-O	Low	
117	WE4/	(5PN)	I/O	Low	VRAM Write Enables for pixels 4:0 of the nugget, respectively. WE4/ is only used in 5-pixel nugget configurations (it is unused in 4-pixel nugget configurations, such as the basic four 1M-VRAM minimum configuration). WE4/ has an internal pullup and should be connected to RESOUT/ or GND to configure the 82C481 for 4-pixel nuggets. The state of WE4/ at reset (called the 5PN or '5-Pixel Nugget' bit) is saved in Extension Register EC2[11] (read/write) and in the Memory Control register MEM_CNTL[0] as part of the horizontal configuration (HORCFG) bitfield.
129	WE3/		Tri-O	Low	
138	WE2/		Tri-O	Low	
150	WE1/		Tri-O	Low	
2	WE0/		Tri-O	Low	
85	WE0A/		Tri-O	Low	VRAM Alternate Write Enable. This signal along with WEA3:1/ constitute the alternate nibble write enable signals. They are enabled on reset by pulling down pin 104 with a 2.2KΩ resistor. They are used in combination with CAS01/ to create a nibble mode 2048x1024x4bpp frame buffer.
105	DTOE/		Tri-O	Low	Data Transfer / Output Enable for all VRAM chips
86	FWE		Tri-O	High	Flash Write Enable. This VRAM control signal may be used to generate Flash Write and Color Register Set cycles for VRAMs which support these functions. It is low after reset and can be enabled through Extended Configuration Register EC1[5].
87	CAS01/		Tri-O	Low	VRAM Column Address strobe for pixels P2 and P3 of the first memory bank. CAS0/ = P0, P1, and P4.



PIN DESCRIPTIONS

T-52-33-45

Pin #	Pin Name	Type	Active	Description								
62	MCLK	In	High	Memory Clock. MCLK clocks everything except the CRT control logic (which uses NCLK). The MCLK frequency is selected to match the speed of the RAMs used: <table border="1" style="margin-left: 20px;"> <thead> <tr> <th>MCLK</th> <th>VRAM Access (projected)</th> </tr> </thead> <tbody> <tr> <td>36 MHz</td> <td>120 ns</td> </tr> <tr> <td>45 MHz</td> <td>100 ns</td> </tr> <tr> <td>50 MHz</td> <td>80 ns</td> </tr> </tbody> </table>	MCLK	VRAM Access (projected)	36 MHz	120 ns	45 MHz	100 ns	50 MHz	80 ns
MCLK	VRAM Access (projected)											
36 MHz	120 ns											
45 MHz	100 ns											
50 MHz	80 ns											
88	NCLK	In	High	Nugget Clock. Used to generate timing inside the 82C481 chip. 82C481 internal logic is clocked on the rising edge of NCLK. HSYNC is delayed by one half NCLK cycle and is clocked on the falling edge of NCLK. The NCLK frequency is equal to or half of the VRAM serial data rate. Max pin freq = 40MHz. Max. internal post-divide freq = 32MHz. (See EC1[12:10])								
95	CSEL2	(INTERLEAVE) Tri-O	High	Video Clock Select. These pins are multiplexed if Static Status Enable (EC1[4]) = 0 (default). When BLANK/=0 (blank active), CSEL2:0 are used to select one of up to eight frequencies using external clock selection logic. The selected frequency is used to clock the external video shift registers and RAMDAC. It is divided by 1,2,4,5,8, or 10 for input on NCLK. CSEL2:0 are controlled by EC3[10:8] (CSEL0 is duplicated in ADVFUNC_CNTL[2]). While BLANK/=1 (blank inactive), these pins output INTERLEAVE, 5PN (5-pixel nugget), and PS8 (Pseudo-8-plane mode) bits. 5PN is MEM_CNTL[0]. PS8 mode is selected by setting VRTCFCG=00 (MEM_CNTL[3:2]) (normal setting is 01). If EC1[4]=1, then these pins always output the clock select data. In UISA mode, CSEL1 and CSEL0 may be used to output MEMR/ and MEMW/ signals decoded for the VGA range. This is useful for implementing a local VGA which only decodes addresses A16:0. Refer to the description of extended configuration register EC0[7:6] to enable this feature.								
96	CSEL1	(5PN) (VMEMR/) Tri-O	High									
97	CSEL0	(PS8) (VMEMW/) Tri-O	High									
93	AF	(BANK)	Tri-O	High	Advanced Function is multiplexed with BANK if Static Status Enable (EC1[4]) = 0 (default). If BLANK/=0, indicates Advanced Function (ADVFUNC_CNTL[0]); 1=82C481 drives the video connector, 0=external logic (usually a VGA) drives the video connector. If BLANK/=1, indicates BANK, used by external logic to select which serial output enables (SOE3:0/) to activate for a particular scan line in 4-bank configurations: BANK=0 selects SOE1:0/; BANK=1 selects SOE3:2/. If EC1[4]=1, then AF always outputs ADVFUNC_CNTL[0].							



PIN DESCRIPTIONS

Pin #	Pin Name	Type	Active	Description
83	PALRD/	Tri-O	Low	Connected to the Read input of the Palette DAC (Bt485, TLC34075, Bt471, or compatible). Asserted when the 82C481 is enabled and an I/O Read occurs to addresses x2EAh-x2EDh (or x3C6h-x3C9h in VGA pass-through mode with EC1[15]=1). Tristate during reset.
84	PALWR/	Tri-O	Low	Connected to the Write input of the Palette DAC (Bt485, TLC34075, Bt471, or compatible). Asserted when the 82C481 is enabled and an I/O Write occurs to addresses x2EAh-x2EDh (or x3C6h-x3C9h in VGA pass-through mode). Tristate during reset.
82	8BITDAC (ABLANK/)	I/O	High	If EC2[11]=0 then this pin is used to control the '6/8-Bit-Analog-Output' pin of a Bt478 or equivalent Palette DAC (0=6-bit, 1=8-bit). This pin is sampled at reset, the state is loaded into EC2[13], then this pin becomes an output driven by EC2[13]. This pin and register bit can be used as a general purpose output with a reset-sampled default value. If EC2[11]=1 then this pin is redefined as an Alternate Blank/ output. It is controlled by the horizontal and vertical alternate blank registers at I/O address 32E8h - 3EE8h.
90	HSYNC	Tri-O	Both	Horizontal and Vertical Sync signals for the monitor and Blanking signal for the external palette DAC. Sync polarities are programmable. Tristated during reset. All timing is generated with respect to NCLK.
89	VSYNC	Tri-O	Both	
94	BLANK/	Tri-O	Low	
92	VHSYNC	In	Both	Horizontal and Vertical Sync signals from external VGA. When not in Advanced Function (AF) mode (i.e., 82C481 not enabled), these signals are used to drive the HSYNC and VSYNC outputs instead of the 82C481 H/V Sync.
91	VVSYNC	In	Both	
73	SENSE	In	High	Sense Input for analog output and monochrome/color monitor connection testing. For compatibility, this pin should be connected to the outputs of an LM339 comparator or to the sense pin of the RAMDAC. The SENSE input may be read via software as bit-0 of the Display Status register at 02E8h.



PIN DESCRIPTIONS

Video Interface

Pin #	Pin Name	Type	Active	Description
104	FRAME	Tri-O	Both	<p>Odd/Even frame for use with external cursor hardware when in interlaced modes. Must be enabled through EC1[7]. Default is tri-state.</p> <p>0 Even field 1 Odd field</p> <p>During RESET the inverted state of this pin is latched in WEN (EC1[3]). It is used to determine if the nibble write enable signals and CAS01/ should be enabled. As sampled at pin 104 during reset:</p> <p>0 Enable CAS01/ and WE3A:0A 1 82C480 compatible (default)</p>

ADVANCE
PRODUCT
INFORMATION



PIN DESCRIPTIONS

Test, Power, and Ground

Pin #	Pin Name	Type	Active	Description
1	VCC	P	-	Power Pins
20	VCC	P	-	
40	VCC	P	-	
81	VCC	P	-	
100	VCC	P	-	
120	VCC	P	-	
140	VCC	P	-	
11	GND	P	-	Ground Pins
21	GND	P	-	
41	GND	P	-	
42	GND	P	-	
79	GND	P	-	
80	GND	P	-	
101	GND	P	-	
107	GND	P	-	
121	GND	P	-	
122	GND	P	-	
139	GND	P	-	
141	GND	P	-	
159	GND	P	-	
160	GND	P	-	

ADVANCE
PRODUCT
INFORMATION



Registers

T-52-33-45

Register Mnemonic	Register Name	Read Access	Write Access	Bits	Register Type	Page
POS_2	Setup Control	0102	0102	1	POS	25
DISP_STAT	Display Status	02E8*	N/A	3	8514/A	25
H_TOTAL	Horizontal Total	26E8*	02E8*	9	8514/A	26
DAC_MASK	DAC Mask	02EA	02EA†	8	RAMDAC	26
DAC_R_INDEX	DAC Read Index	02EB	02EB†	8	RAMDAC	27
DAC_W_INDEX	DAC Write Index	02EC	02EC†	8	RAMDAC	27
DAC_DATA	DAC Data	02ED	02ED†	8	RAMDAC	28
H_DISP	Horizontal Displayed	06E8*	06E8*	8	8514/A	28
H_SYNC_STRT	Horizontal Sync Start	0AE8*	0AE8*	8	8514/A	29
H_SYNC_WID	Horizontal Sync Width	0EE8*	0EE8*	6	8514/A	29
V_TOTAL	Vertical Total	12E8*	12E8*	12	8514/A	30
V_DISP	Vertical Displayed	16E8*	16E8*	12	8514/A	30
V_SYNC_STRT	Vertical Sync Start	1AE8*	1AE8*	12	8514/A	31
V_SYNC_WID	Vertical Sync Width	1EE8*	1EE8*	6	8514/A	31
DISP_CNTL	Display Control	22E8*	22E8*	7	8514/A	32
H_AB_START	Horizontal Alternate Blank Start		32E8*	9	CHIPS	33
H_AB_END	Horizontal Alternate Blank End		36E8*	9	CHIPS	33
V_AB_START	Vertical Alternate Blank Start		3AE8*	12	CHIPS	34
V_AB_END	Vertical Alternate Blank End		3EE8*	16	CHIPS	34
SUBSYS_STAT	Subsystem Status	42E8*	N/A	16	8524/A	35
SUBSYS_CNTL	Subsystem Control	2EE8*	42E8*	12	8514/A	36
ROM_PAGE_SEL	ROM Page Select	46E8*	46E8*	3	8514/A	37
ADVFUNC_CNTL	Advanced Function Control	4AE8*	4AE8*	2	8514/A	38
EC0	Extended Configuration Register 0	52E8*	52E8*	16	CHIPS	39
EC1	Extended Configuration Register 1	56E8*	56E8*	16	CHIPS	40
EC2	Extended Configuration Register 2	5AE8*	5AE8*	13	CHIPS	42
EC3	Extended Configuration Register 3	5EE8*	5EE8*	15	CHIPS	44
CUR_Y	Current Y Position	82E8*	82E8*	11	8514/A	45
CUR_X	Current X Position	86E8*	86E8*	12	8514/A	46
DESTY_AXSTP	Destination Y Position/Axial Step Constant	8AE8*	8AE8*	13	8514/A	46
DESTX_DIASTP	Destination X Position/Diagonal Step Constant	8EE8*	8EE8*	13	8514/A	47
ERR_TERM	Error Term	92E8*	92E8*	16	8514/A	47
MAJ_AXIS_PCNT	Major Axis Pixel Count/Rectangle Width	96E8*	96E8*	11	8514/A	48
GP_STAT	Graphics Processor Status	9AE8*	N/A	10	8514/A	49
CMD	Command	N/A	9AE8*	16	8514/A	50
SHORT_STROKE	Short Stroke Vector Transfer	9EE8*	9EE8*	16	8514/A	52
BKGD_COLOR	Background Color	A2E8*	A2E8*	8	8514/A	53
FRGD_COLOR	Foreground Color	A6E8*	A6E8*	8	8514/A	54
WRT_MASK	Write Mask	AAE8*	AAE8*	8	8514/A	55
RD_MASK	Read Mask	AEE8*	AEE8*	8	8514/A	56
COLOR_CMP	Color Compare	B2E8*	B2E8*	8	8514/A	57
BKGD_MIX	Background Mix	B6E8*	B6E8*	7	8514/A	58
FRGD_MIX	Foreground Mix	BAE8*	BAE8*	7	8514/A	59
MULTIFUNC_CNTL	Multi-function Control Index (MFC)	N/A	BEE8*	4	8514/A	60
MIN_AXIS_PCNT	Minor Axis Pixel Count	MFC[0]	BEE8*	11	8514/A	60
SCISSORS_T	Top Scissors	MFC[1]	BEE8*	12	8514/A	61
SCISSORS_L	Left Scissors	MFC[2]	BEE8*	12	8514/A	61
SCISSORS_B	Bottom Scissors	MFC[3]	BEE8*	12	8514/A	62
SCISSORS_R	Right Scissors	MFC[4]	BEE8*	12	8514/A	62
MEM_CNTL	Memory Control	MFC[5]	BEE8*	7	8514/A	63
PATTERN_L	Fixed Pattern Low	MFC[8]	BEE8*	8	8514/A	64
PATTERN_H	Fixed Pattern High	MFC[9]	BEE8*	5	8514/A	65
PIX_CNTL	Pixel Control	MFC[A]	BEE8*	8	8514/A	66
PIX_TRANS	Pixel Data Transfer	E2E8*	E2E8*	8/16	8514/A	67

* Indicates 16-bit read/write access at port addresses xxx8/xxx9.

† When in VGA Pass-through mode, write accesses to 3C6-3C9h are mirrored in the 82C481 RAMDAC.



Registers Bit Summary

T-52-33-45

Register	I/O	15	14	13	12	11	10	9	8	7	6	5	4	3	2	1	0		
DISP_STAT	02E8	0	0	0	0	0	0	0	0	0	0	0	0	0	TOG	VBK	SENS		
H_TOTAL	26E8	0	0	0	0	0	0	0	H TOTAL + 1										
DAC_MASK	02EA	X	X	X	X	X	X	X	X	PALETTE MASK									
DAC_R_INDEX	02EB	X	X	X	X	X	X	X	X	READ INDEX									
DAC_W_INDEX	02EC	X	X	X	X	X	X	X	X	WRITE INDEX									
DAC_DATA	02ED	X	X	X	X	X	X	X	X	RAMDAC DATA REGISTER									
H_DISP	06E8	0	0	0	0	0	0	0	HORIZONTAL DISPLAYED										
H_SYNC_START	0AE8	0	0	0	0	0	0	0	0	HORIZONTAL SYNC START									
H_SYNC_WID	0EE8	0	0	0	0	0	0	0	0	0	POL	H SYNC WIDTH							
V_TOTAL	12E8	0	0	0	0	VERTICAL TOTAL BASE									VTADJ				
V_DISP	16E8	0	0	0	0	VERTICAL DISPLAYED BASE									VDADJ				
V_SYNC_STRT	1AE8	0	0	0	0	VERTICAL SYNC START BASE									VSADJ				
V_SYNC_WID	1EE8	0	0	0	0	0	0	0	0	0	POL	V SYNC WIDTH							
DISP_CNTL	22E8	0	0	0	0	0	0	0	0	0	DISPEN	INL	DBL	MEMCFG	ODD				
H_AB_START	32E8	0	0	0	0	0	0	0	0	HORIZONTAL ALTERNATE BLANK START									
H_AB_END	36E8	0	0	0	0	0	0	0	HORIZONTAL ALTERNATE BLANK END										
V_AB_START	3AE8	0	0	0	0	VERTICAL ALTERNATE BLANK START									VASADJ				
V_AB_END	3EE8	BEN	BHE	BNE	BLE	VERTICAL ALTERNATE BLANK END									VAEADJ				
SUBSYS_STAT	42E8R	CHIP ID				CHIP REV				8BP	MON ID			GPI	IIO	PF	VBF		
SUBSYS_CNTL	42E8W	GPCTRL		CHPTST	IGPI	IIO	IPF	IVBF	0	0	0	0	RGPI	RIIO	RPF	RVBF			
ROM_PAGE_SEL	46E8	0	0	0	0	0	0	0	0	0	0	VGA	VGA	ROM PAGE					
ADVFUNC_CNTL	4AE8	0	0	0	0	0	0	0	0	0	0	0	0	CLK0	1	AF			
EC0	52E8	I/O BASE ADDRESS								ABE	ZWS	CSE	VME	VMR			PTR		
EC1	56E8	PRE	SNIB	NUGGET	DIV	PAT	VEN	QFEN	FEN	YPM	FWE	SSE	WEN	CEN	M32	M16			
EC2	5AE8	0	0	DAC	0	5PN	1M	BANKS	8BP	RPG	RSIZ	ROMBASE	1	1	1				
EC3	5EE8	MON ID			OVR	0	CLK2	CLK1	CLK0	ALE	AHE	ALS	AHS	MFC REG INDEX					
CUR_Y	82E8	0	0	0	0	0	Y-POSITION												
CUR_X	86E8	0	0	0	0	X-POSITION													
DESTY_AXSTP	8AE8	0	0	0	SGN	Y-DESTINATION / AXIAL STEP CONSTANT													
DESTX_DIASTP	8EE8	0	0	0	SGN	X-DESTINATION / DIAGONAL STEP CONSTANT													
ERR_TERM	92E8	R/W	R/W	R/W	INITIAL ERROR TERM														
MAJ_AXIS_PCNT	96E8	0	0	0	0	MAJOR AXIS PIXEL COUNT / RECTANGLE WIDTH													
GP_STAT	9AE8R	0	0	0	0	0	0	BSY	RDY	QUEUE STATE									
CMD	9AE8W	COMMAND			BSQ	0	0	16B	PCD	INCY	MAJ	INCX	DRW	TYP	LAST	AP	WRT		
SHORT_STROKE	9EE8	ANGLE			DRW	LENGTH			ANGLE			DRW	LENGTH						
BKGD_COLOR	A2E8	0	0	0	0	0	0	0	0	BACKGROUND COLOR									
FRGD_COLOR	A6E8	0	0	0	0	0	0	0	0	FOREGROUND COLOR									
WRT_MASK	AAE8	0	0	0	0	0	0	0	0	WRITE MASK									
RD_MASK	AAE8	0	0	0	0	0	0	0	0	READ MASK									
COLOR_CMP	B2E8	0	0	0	0	0	0	0	0	COLOR COMPARE									
BKGD_MIX	B6E8	0	0	0	0	0	0	0	0	0	BSS	BACKMIX							
FRGD_MIX	BAE8	0	0	0	0	0	0	0	0	0	FSS	FOREMIX							
MULTIFUNC_CNTL	BEE8	INDEX				X	X	X	X	X	X	X	X	X	X	X	X		
MIN_AXIS_PCNT	BEE8	0	0	0	0	0	MINOR AXIS PIXEL COUNT/ RECT HEIGHT												
SCISSORS_T	BEE8	0	0	0	1	TOP SCISSORS													
SCISSORS_L	BEE8	0	0	1	0	LEFT SCISSORS													
SCISSORS_B	BEE8	0	0	0	1	BOTTOM SCISSORS													
SCISSORS_R	BEE8	0	1	0	0	RIGHT SCISSORS													
MEM_CNTL	BEE8	0	1	0	1	0	0	0	0	0	CRS	FWS	SWP	VRTCFG	HORCFG				
PATTERN_L	BEE8	1	0	0	0	0	0	0	0	0	0	MASK LOW							
PATTERN_H	BEE8	1	0	0	1	0	0	0	0	0	0	MASK HIGH							
PIX_CNTL	BEE8	1	0	1	0	0	0	0	0	MIXSEL	COLCMPOP			PMODE	INA				
PIX_TRANS	E2E8	PIXEL/PLANE DATA									PIXEL/PLANE DATA								



SETUP CONTROL REGISTER

(POS_2)

Read at I/O Address 102h

Write at I/O Address 102h

Byte Accessible only

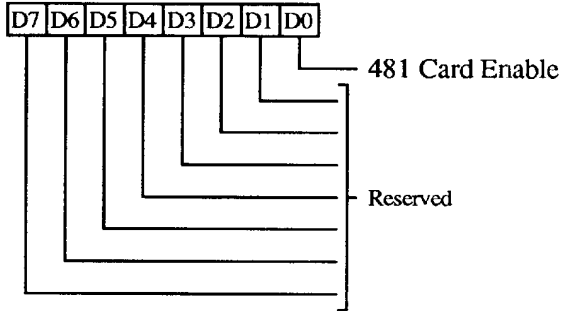

- 0 481 Card Enable
 - 1 = Card enabled
 - 0 = Card disabled (all registers and memory invisible to system except POS Setup registers).

7-1 Reserved (0)

DISPLAY STATUS REGISTER

(DISP_STAT)

Read only at I/O Address 02E8h

Byte or Word Accessible

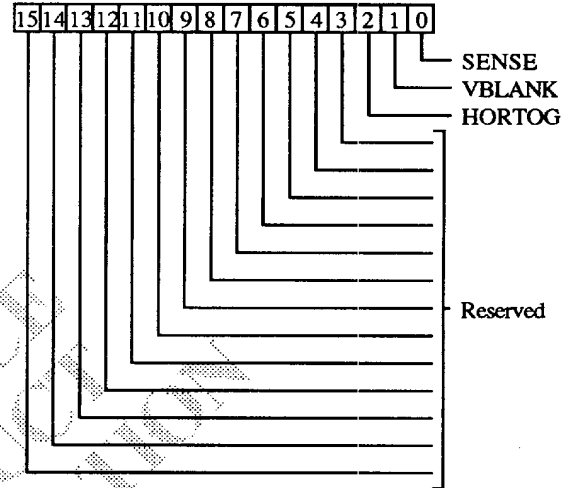

- 0 SENSE is the result of a wired-OR of comparators on each of the RGB video signals. This sense input may be used to determine if a color, monochrome or no monitor is connected to the analog connector. The RAMDAC expects to be driving a 75Ω matched impedance cable. The comparator reference voltage is generally chosen to be approximately half of the full scale DAC output. By programming the RAMDAC for various voltage outputs and patterns and then reading SENSE, the monitor type can be deduced.
- 1 VBLANK Vertical Blank State
 - 0 = Vertical Blank inactive
 - 1 = Vertical Blank active
- 2 HORTOG Horizontal Toggle reads the state of a flip-flop which is clocked by HSYNC; the beginning of the sync pulse (which generally occurs after the end of displayed data) can be detected by polling this bit and waiting for a change of state.

15-3 Reserved (0)



T-52-33-45

**HORIZONTAL TOTAL REGISTER
(H_TOTAL)**

Read at I/O Address 26E8h
Write at I/O Address 02E8h
Byte or Word Accessible

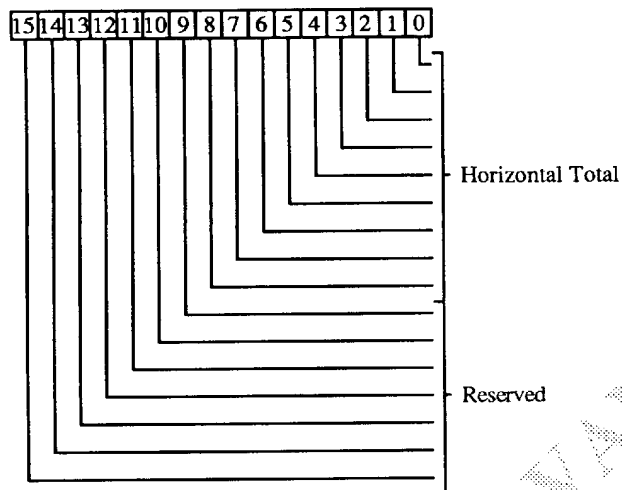

**DAC MASK REGISTER
(DAC_MASK)**

Read/Write at I/O Address 2EAh
Write at I/O Address 03C6h (VGA Mode Only)
Read at I/O Address 03C6h (AF=0 and PRE=1)
Byte Accessible only

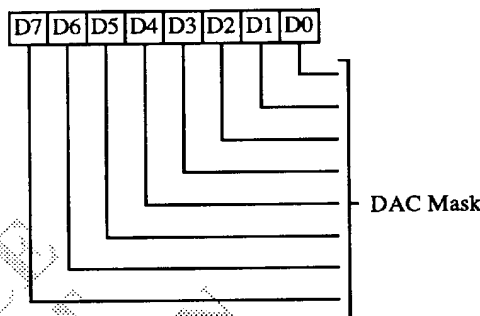

8-0 Horizontal Total defines the total horizontal scan line width including the display, blank, and sync times. All horizontal timings are measured in terms of the nugget clock, the NCLK divisor, and the state of MEM_CNTL[0] (4pixel/5pixel nuggets). By definition, H_TOTAL is measured from the start of the first displayed pixel on the scan line. Therefore, the total time per scan line is:

$$(H_TOTAL + 1) * (NCD[2:0] + 1) NCLK \text{ periods.}$$

15-9 Reserved (0)

7-0 DAC Mask. This register is in the RAMDAC Color Palette. Pixel data bits are ANDed with the DAC Mask before going to the palette. This can be used to split the display buffer into multiple buffers by alternately enabling different planes.

The 82C481 palette registers may be written at their equivalent VGA I/O addresses when the 82C481 is in VGA pass-through mode. This allows the 82C481 palette to mirror the contents of the VGA palette hence displaying the correct colors when outputting VGA pass-through video. This is required for 8514/a compatibility.

The 82C481 responds to I/O read accesses to the VGA palette only if PRE, EC1[15]=1. This is useful if both a VGA and the 82C481 are sharing the same RAMDAC. In this case however, the 82C481 relies on the VGA to generate the necessary wait states.

Note: Only A9:0 are used in the decode of the 8514/a palette addresses. The PALRD/ and PALWR/ signals are generated for all addresses which map into ranges x2EAh - x2EDh (eg. 06EAh - 06EDh. 12EAh - 12EDh or FAEA h - FAEDh). The VGA palette addresses use all 16 I/O address lines to decode their 03C6h-03C9h range.

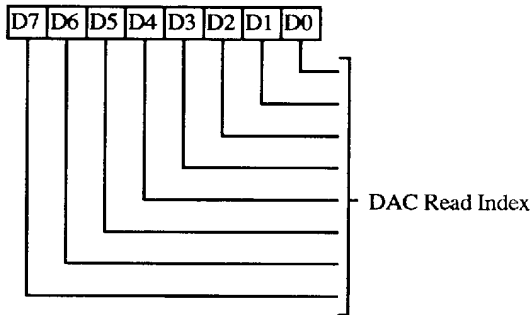
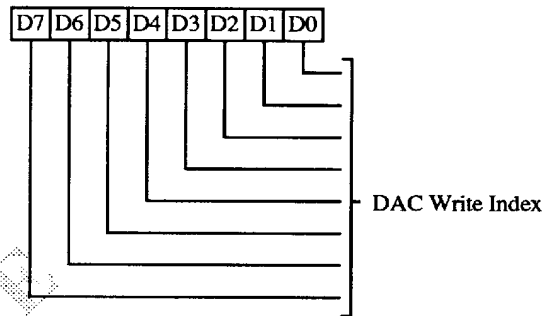
**DAC READ INDEX REGISTER
(DAC R INDEX)***Read/Write at I/O Address 2EBh**Write at I/O Address 03C7h (VGA Mode Only)**Read at I/O Address 03C7h (AF=0 and PRE=1)**Byte Accessible only***DAC WRITE INDEX REGISTER
(DAC W INDEX)***Read/Write at I/O Address 2ECh**Write at I/O Address 03C8h (VGA Mode Only)**Read at I/O Address 03C8h (AF=0 and PRE=1)**Byte Accessible only*

7-0 DAC Read Index. This register is in the RAMDAC Color Palette.

The DAC Read Index is used to point to the location in the RAM lookup table which will be read by the current sequence of I/O reads to the DAC_DATA register. To read the contents of a location in the RAM palette:

1. Write the RAM address for that location to the DAC Read Index register. The data in the RAMDAC at that address is read into the DAC_DATA register. The DAC Read Index register auto-increments to point to the next RAMDAC address location. Address location 0FFh wraps around to 0.
2. The palette data for that location may then be read by three consecutive accesses to the DAC_DATA register; one each for Red, Green, and Blue palette data (6 or 8 bits).

Upon completion of the third read to the DAC_DATA register, the 18/24 bits of data for the next address location is available to be read from the DAC_DATA register.

The IBM 8514/A and VGA both use an 18-bit wide color palette (6 bits each for Red, Green, and Blue). The 82C481 supports both 6 and 8 bit RAMDACs.

7-0 DAC Write Index. This register is in the RAMDAC Color Palette.

The DAC Write Index is used to point to the location in the RAM lookup table which will be loaded following the completion of a triple write sequence to the DAC_DATA register. To update a location in the RAM palette:

1. Write the RAM address for that location to the DAC Write Index register.
2. In three consecutive writes to the DAC_DATA register, output Red, Green, and Blue palette data (6 or 8 bits).

Upon completion of the third write to the DAC_DATA register, the 18/24 bits of palette data is transferred to the RAMDAC lookup table. The DAC Write Index is then incremented to point to the next RAMDAC address location. Address location 0FFh wraps around to 0.

The IBM 8514/A and VGA both use an 18-bit wide color palette (6 bits each for Red, Green, and Blue). The 82C481 supports both 6 and 8 bit RAMDACs.



**DAC DATA REGISTER
(DAC_DATA)**

Read/Write at I/O Address 2EDh
Write at I/O Address 03C9h (VGA Mode Only)
Read at I/O Address 03C9h (AF=0 and PRE=1)
Byte Accessible only

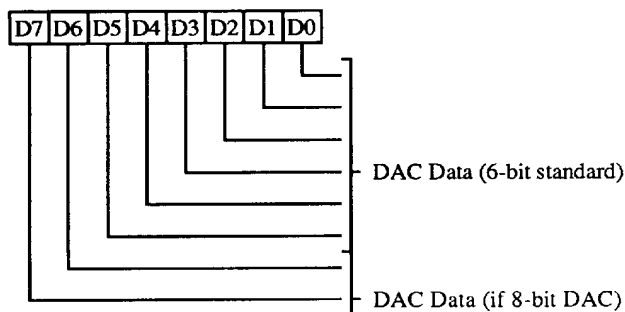

7-0 DAC Data. This register is in the RAMDAC Color Palette.

To write a new color for a pixel, first write its address to DAC_W_INDEX, then write the red, green, and blue values consecutively to DAC_DATA. After the blue value is written, all three color values are simultaneously transferred to the palette, and DAC_W_INDEX is incremented to point to the next palette word. This allows writing the whole palette with only one write to the DAC_W_INDEX register.

To read a color value, first write its address to DAC_R_INDEX; this causes that location's value to be copied into a temporary register (18 or 24-bit) and DAC_R_INDEX to be incremented. Then the red, green, and blue values (6 or 8-bit) may be read consecutively by reading the DAC_DATA register. As soon as the blue value is read, the next location's color data is transferred to the temporary register and DAC_R_INDEX is again incremented. This allows reading of the whole palette with only one write of the DAC_R_INDEX register.

The IBM 8514/A and VGA both use an 18-bit wide color palette (6 bits each for Red, Green, and Blue). The 82C481 supports both 6 and 8 bit RAMDACs.

**HORIZONTAL DISPLAYED REGISTER
(H_DISP)**

Read at I/O Address 06E8h (Chips Extension)
Write at I/O Address 06E8h
Byte or Word Accessible

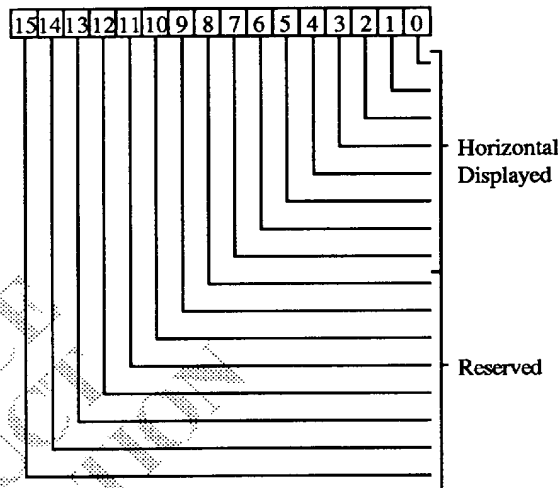

7-0 Horizontal Displayed defines both the number of displayed pixels per scan line and the start of the horizontal blanking. All horizontal timings are performed in terms of double nuggets. The start of the horizontal blanking signal occurs at:

$$(H_DISP + 1) * (NCD[2:0] + 1)$$

NCLK periods after the start of the scan line.

15-8 Reserved (0)



**HORIZONTAL SYNC START REGISTER
(H_SYNC STRT)**

Read at I/O Address 0AE8h (Chips Extension)
Write at I/O Address 0AE8h
Byte or Word Accessible

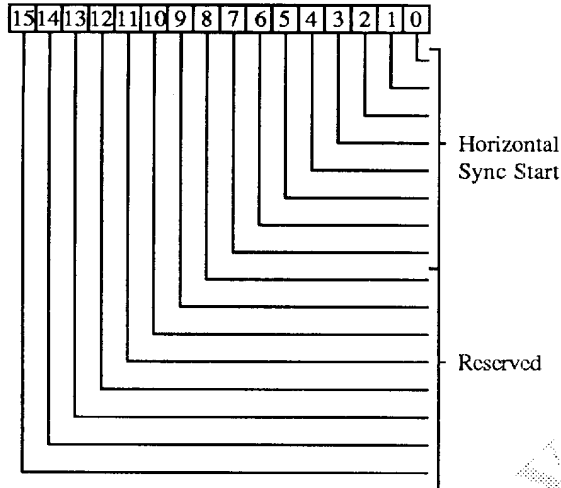

**HORIZONTAL SYNC WIDTH REGISTER
(H_SYNC WID)**

Read at I/O Address 0EE8h (Chips Extension)
Write at I/O Address 0EE8h
Byte or Word Accessible

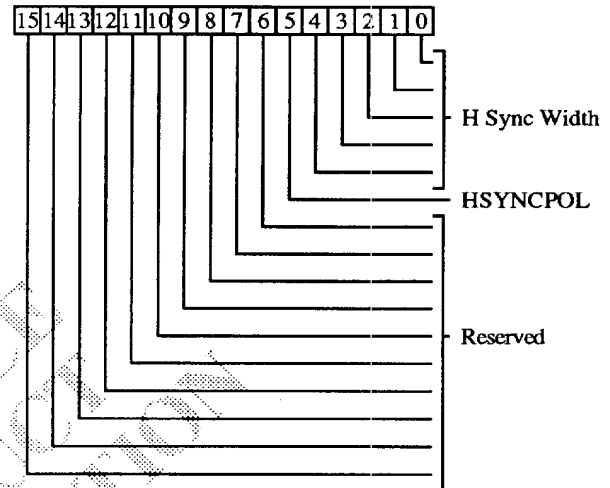

7-0 Horizontal Sync Start defines the timing delay of the horizontal sync signal from the start of a scan line. For HSYNC to occur, H_SYNC_STRT must be less than H_TOTAL. The horizontal sync pulse begins at $(H_SYNC_STRT + 1) * (NCD[2:0] + 1)$ NCLK periods after the beginning of a scan line.

15-8 Reserved (0)

4-0 Horizontal Sync Width defines the width of the horizontal sync pulse. The horizontal sync pulse is independent of Horizontal Total in that the end of a scan line does not terminate the HSYNC signal. The width of the pulse is:

$$H \text{ Sync Width} * (NCD[2:0] + 1) \text{ NCLK periods.}$$

5 HSYNCPOL (Horizontal Sync Polarity)

- 1 = Negative (-)
- 0 = Positive (+)

The horizontal and vertical sync polarities are used to indicate the horizontal and vertical frame times to some IBM monitors as described below:

Horizontal Sync Polarity	Vertical Sync Polarity	Horizontal Scan Freq (KHz)	Vertical Scan Freq (Hz)
-	-	31.47	59.94
-	+	31.47	70.08
+	-	31.47	70.08
+	+	35.52	43.48

15-6 Reserved (0)



VERTICAL TOTAL REGISTER

(V_TOTAL)

Read at I/O Address 12E8h (Chips Extension)

Write at I/O Address 12E8h

Byte or Word Accessible

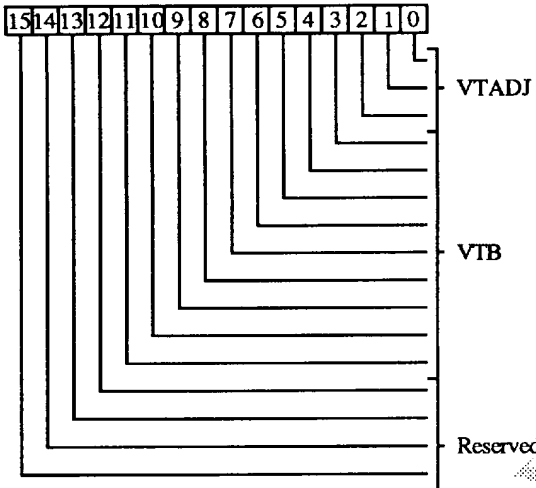

- 2-0 VTADJ (Vertical Total Adjust)
- 11-3 VTB (Vertical Total Base)

The Vertical Total value is calculated from VTB, VTADJ, and the Scan Modulus. The internal vertical counter is incremented at the end of every scan line when in non-interlaced mode. When in interlaced mode, the vertical counter increments every half scan line (ie. when the horizontal counter reaches H_TOTAL+2 and H_TOTAL). For true interlacing to occur, Vertical Total must be programmed to an odd number of half scan lines (ie. VTADJ is even).

$$\text{Vertical Total} = (\text{Modulus} * \text{VTB}) + \text{VTADJ} + 1$$

The Scan Modulus is calculated from the DBLSCAN and MEMCFG bits of the DISP_CNTL register as follows:

DBLSCAN	MEMCFG	Scan Modulus
0	00	2
0	01	4
0	10	6
0	11	8
1	00	4
1	01	8
1	10	12
1	11	16

15-12 Reserved (0)

VERTICAL DISPLAYED REGISTER

(V_DISP)

Read at I/O Address 16E8h (Chips Extension)

Write at I/O Address 16E8h

Byte or Word Accessible

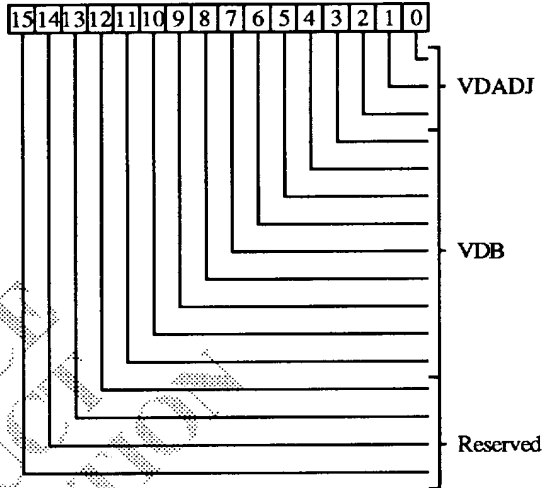

- 2-0 VDADJ (Vertical Displayed Adjust)
- 11-3 VDB (Vertical Displayed Base)

The Vertical Displayed value is calculated from VDB, VDADJ, and the Scan Modulus (opposite). The internal vertical counter is incremented at the end of every scan line when in non-interlaced mode; every half scan line (ie. when the horizontal counter reaches H_TOTAL+2 and H_TOTAL) when in interlaced mode. The Vertical Displayed value also determines the starting location for the Vertical Blank signal. The Vertical Blank signal is synchronized to the end of a scan line (full H_TOTAL).

$$\text{Vertical Disp} = (\text{Modulus} * \text{VDB}) + \text{VDADJ} + 1$$

Since Vertical Total must be odd when in interlaced mode, scan lines have an alternating odd/even relationship with the half scan line count in alternate frames. (In even frames, the vertical counter begins counting at the start of a full scan line and ends on a half scan line. In the odd frame which follows, the vertical counter begins on a half scan line and ends on a full scan line.) Because Vertical Blank is synchronized to full H_TOTAL, the Vertical Blank pulse for even frames is delayed by H_TOTAL+2 and is shorter by this amount in odd frames.

15-12 Reserved (0)



**VERTICAL SYNC START REGISTER
(V_SYNC_STRT)**

Read at I/O Address 1AE8h (Chips Extension)
Write at I/O Address 1AE8h
Byte or Word Accessible

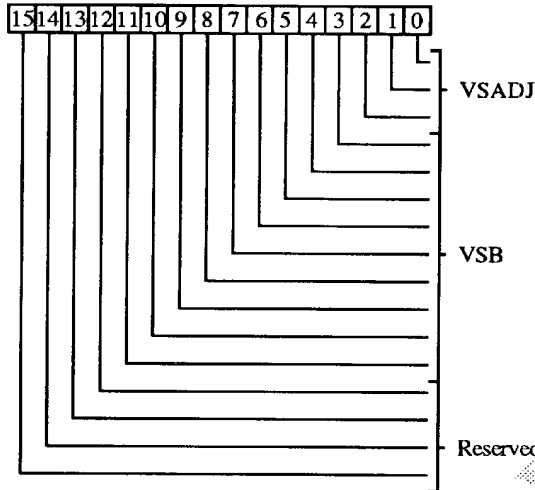

**VERTICAL SYNC WIDTH REGISTER
(V_SYNC_WID)**

Read at I/O Address 1EE8h (Chips Extension)
Write at I/O Address 1EE8h
Byte or Word Accessible

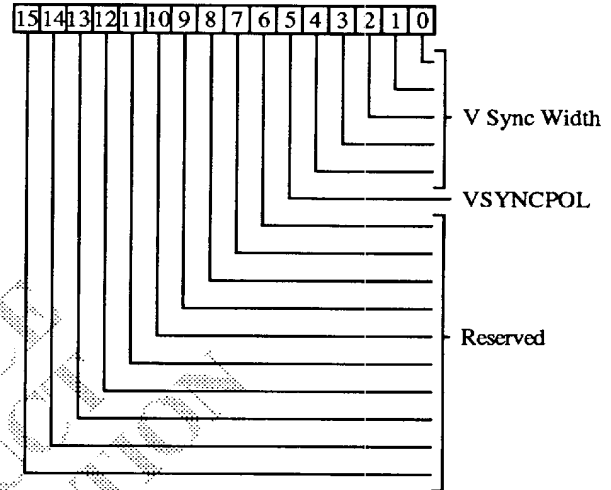

- 2-0 VSADJ (Vertical Sync Start Adjust)
- 11-3 VSB (Vertical Sync Start Base)

The Vertical Sync Start value is calculated from VSB, VSADJ, and the Scan Modulus. The internal vertical counter register is incremented at the end of every scan line when in non-interlaced mode. When in interlaced mode, the vertical counter increments every half scan line (i.e. when the horizontal counter reaches H_TOTAL+2 and H_TOTAL). The Vertical Sync signal is not synchronized to the end of a scan line (full H_TOTAL) as is the Vertical Blank.

$$\text{VsyncStart} = (\text{VSB} * \text{Modulus}) + \text{VSADJ} + 1$$

The Scan Modulus is calculated from the DBLSCAN and MEMCFG bits of the DISP_CNTL register as follows:

DBLSCAN	MEMCFG	Scan Modulus
0	00	2
0	01	4
0	10	6
0	11	8
1	00	4
1	01	8
1	10	12
1	11	16

- 15-12 Reserved (0)

- 4-0 Vertical Sync Width defines the width of the vertical sync pulse in scan lines. The vertical sync pulse is independent of Vertical Total so that when the vertical counter reaches Vertical Total, the VSYNC signal is not terminated. When in interlaced mode, the pulse width is counted in half scan lines.
- 5 VSYNCPOL (Vertical Sync Polarity)
 - 1 = Negative (-)
 - 0 = Positive (+)

The horizontal and vertical sync polarities are used to indicate the horizontal and vertical frame times to some IBM monitors as described below:

Horizontal Sync Polarity	Vertical Sync Polarity	Horizontal Scan Freq (KHz)	Vertical Scan Freq (Hz)
-	-	31.47	59.94
-	+	31.47	70.08
+	-	31.47	70.08
+	+	35.52	43.48

- 15-6 Reserved (0)



**DISPLAY CONTROL REGISTER
(DISP_CNTL)**

Read at I/O Address 22E8h (Chips Extension)

Write at I/O Address 22E8h

Byte or Word Accessible

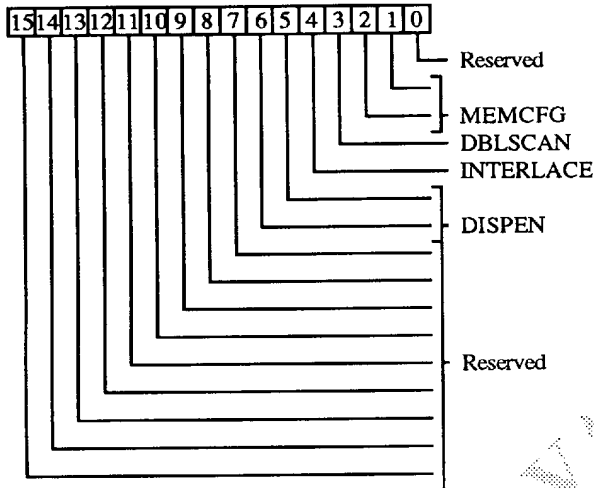

6-5 DISPEN (Display Enable)

6 5 Function

0	0	No effect
0	1	Enable Hsync, Vsync, Blank, data transfer cycles, and refresh cycles
1	x	Disable Hsync, Vsync, Blank, data transfer cycles, and refresh cycles

Bits 6:5 control an R-S latch. The output of this latch is read back in bit 5; bit 6=0.

15-7 Reserved (0)

NOTE: INTERLACE, DBLSCAN, and MEMCFG bits are duplicated in each of the alternate video register sets.

0 Reserved (0)

2-1 MEMCFG (Memory Configuration)

MEMCFG	Scan Lines per VRAM Row Address
0 0	1
0 1	2
1 0	3
1 1	4

Note: If two or more banks of VRAM are present the data is horizontally interleaved. This means that each VRAM Row Address has twice the data as in a single bank implementation. For example with 2 banks (2MByte) each row address contains 4096 bytes (512bits x 4 bit/VRAM x 8 VRAMs/bank * 2 banks). If a 1280x1024x8bpp display is desired, then MEMCFG must be set to 01. This configures the frame buffer to 2048x1024 at 8bpp which will fit the display horizontally and vertically.

3 DBLSCAN (Double Scan).

- 0 = Single scan
- 1 = Double scanning enabled

4 INTERLACE

- 0 = Non-interlace
- 1 = Interlace



**HORIZONTAL ALT BLANK START REGISTER
(H_AB_STRT)**

Write at I/O Address 32E8h (Chips Extension)
Byte or Word Accessible

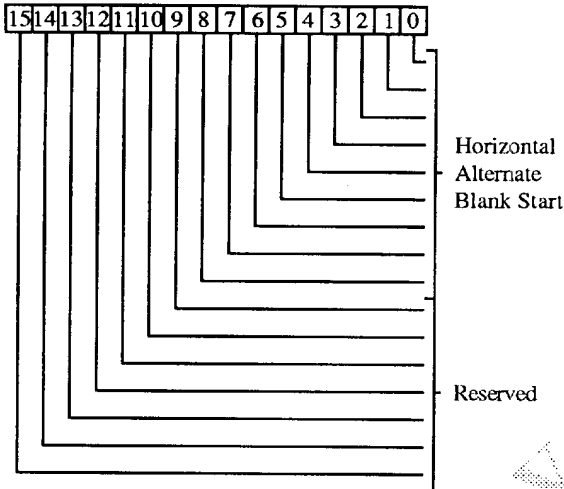

8-0 Horizontal Alternate Blank Start defines the start of the Alternate Blank signal. The horizontal alternate blank pulse begins at

$$(H_AB_STRT+1) * (NCD2:0)$$

NCLK periods after the beginning of a scan line.

15-9 Reserved (0)

**HORIZONTAL ALT BLANK END REGISTER
(H_AB_END)**

Write at I/O Address 36E8h (Chips Extension)
Byte or Word Accessible

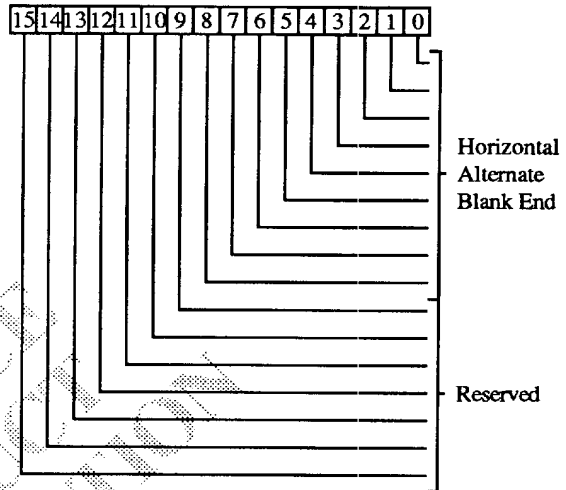

8-0 Horizontal Alternate Blank End defines the stop of the Alternate Blank signal. The horizontal alternate blank pulse ends at

$$(H_AB_END+1) * (NCD2:0)$$

NCLK periods after the beginning of a scan line.

15-9 Reserved (0)



VERTICAL ALT BLANK START REGISTER (V_AB_STRT)

Write at I/O Address 3AE8h (Chips Extension)
Byte or Word Accessible

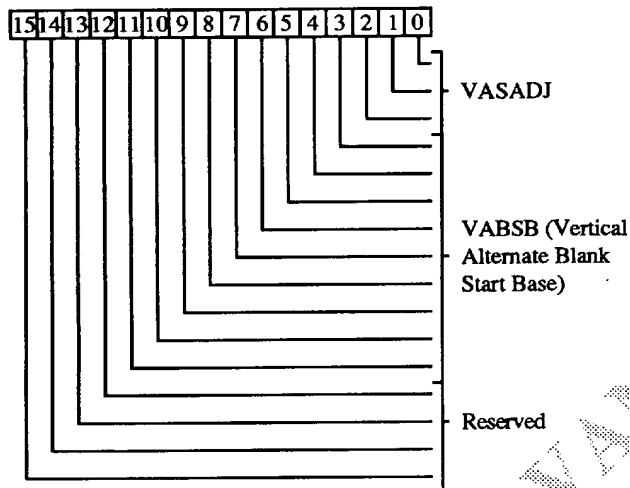

VERTICAL ALT BLANK END REGISTER (V_AB_END)

Write at I/O Address 3EE8h (Chips Extension)
Byte or Word Accessible

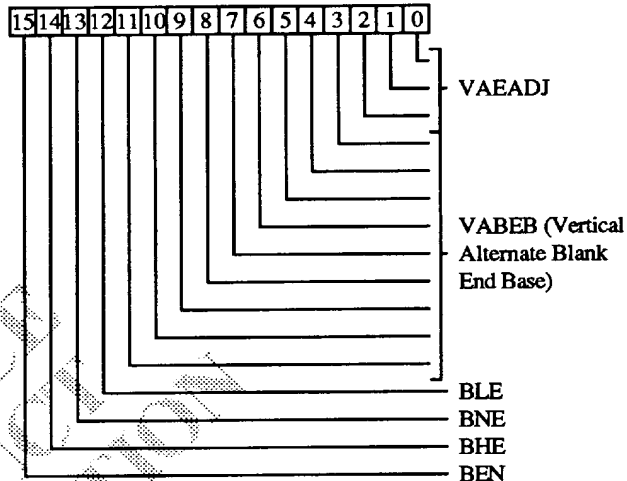

2-0 VASADJ (Vertical Alternate Blank Start Adjust)

11-3 Vertical Alternate Blank Start Base

The Vertical Alternate Blank Start value is calculated from VABSB, VASADJ, and the Scan Modulus. The Vertical Alternate Blank signal is synchronized to the end of a scan line (full H_TOTAL) as is the Vertical Blank.

$$\text{Vertical Alternate Blank Start} = (\text{VSB} * \text{Scan Modulus}) + \text{VSADJ} + 1$$

The Scan Modulus is calculated from the DBLSCAN and MEMCFG bits of the DISP_CNTL register as follows:

DBLSCAN	MEMCFG	Scan Modulus
0	00	2
0	01	4
0	10	6
0	11	8
1	00	4
1	01	8
1	10	12
1	11	16

15-12 Reserved (0)

2-0 VAEADJ (Vertical Alternate Blank End Adjust)

11-3 Vertical Alternate Blank End Base

The Vertical Alternate Blank End value is calculated from VABEB, VAEADJ, and the Scan Modulus in a similar manner as the Vertical Alternate Blank Start.

$$\text{Vertical Alternate Blank Start} = (\text{VSB} * \text{Scan Modulus}) + \text{VSADJ} + 1$$

12 BLE Alternate Blank Alternate Low Resolution Enable

- 0 = Alt Blank is the same as Blank
- 1 = Alt Blank enabled

13 BNE Alternate Blank Normal Resolution Enable

- 0 = Alt Blank is the same as Blank
- 1 = Alt Blank enabled

14 BHE Alternate Blank Alternate High Resolution Enable

- 0 = Alt Blank is the same as Blank
- 1 = Alt Blank enabled

15 BEN Alternate Blank Master Enable

- 0 = EC2[13] output on pin 82 (default)
- 1 = Alt Blank enabled



T-52-33-45

SUBSYSTEM STATUS REGISTER (SUBSYS_STAT)

Read at I/O Address 42E8h
Byte or Word Accessible

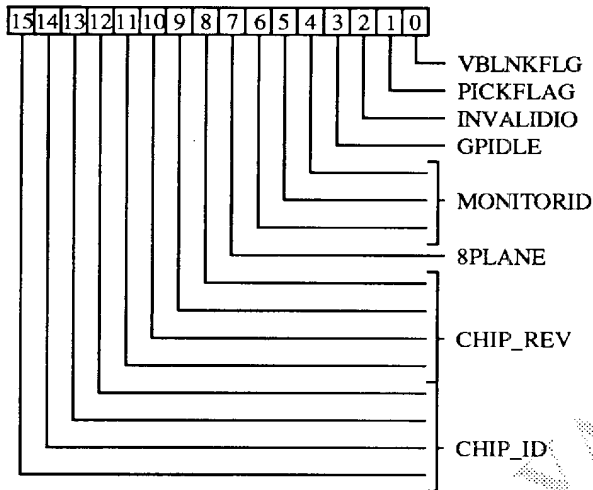

may be modified by writing to the MONITORID latches (R?W) in Extended Configuration Register EC3[15:13].

The MONITORID bits are driven by some monitors to indicate monitor type. The following monitor IDs are returned by IBM and compatible monitors:

Monitor ID	IBM Monitor Type
0 0 0	Reserved
0 0 1	8507 (1024x768) Monochrome
0 1 0	8514 (1024x768) Color
0 1 1	Reserved
1 0 0	Reserved
1 0 1	8503 (640x480) Monochrome
1 1 0	8512/8513 (640x480) Color
1 1 1	Reserved

7 8PLANE - 8 bit planes
Latched on reset from P4D7, 8PLANE emulates the function of the jumper on the IBM 8514/A board. This bit is R/W in Extended Configuration Register EC2[7].

- 0 = 4 planes
- 1 = 8 planes

3-0 Interrupt requests. These bits show the state of internal interrupt requests; these will only activate the IRQ pin if the corresponding Interrupt Enable bit in the SUBSYS_CNTL register is set. Interrupts may only be reset by writing a 1 to the corresponding Interrupt Clear bit in the SUBSYS_CNTL register. The interrupt conditions supported are:

- 0** VBLNKFLG (Vertical Blank Flag) - Vertical blank signal has become active
- 1** PICKFLAG - The current XY position went inside the scissor while executing a line, outline, SSV, bitblt or rectangle command.
- 2** INVALIDIO - The host attempted to write to the queue when no words were available or read from PIX_TRANS when no data was ready.
- 3** GPIDLE - The graphics drawing engine is idle.

11-8 CHIP_REV - Revision number of the silicon. This number, in combination with the CHIP_ID will allow programmers to determine which advanced capabilities are available on this 82C481. Revisions 0-2 indicate 82C480 devices.

3 = 82C481 Initial Release

15-12 CHIP_ID - This field contains the CHIPS ID for 8514/A compatible implementations. It is in accordance with the Video Electronics Standards Association 8514/A specifications.

0 = Chips and Technologies, Inc.

6-4 MONITORID - This field contains the monitor ID bits. If there is no ROM present (ROMCS/ = 0 on reset) and ROMPAGING = 0, then these bits are read directly from pins MS2:0. If there is no ROM present and ROMPAGING = 1, or if there is a ROM, then these bits are the state of the MS2:0 pins latched at reset. In this case, the data



**SUBSYSTEM CONTROL REGISTER
(SUBSYS CNTL)**

Read at I/O Address 2EE8h (Chips Extension)

Write at I/O Address 42E8h

Byte or Word Accessible

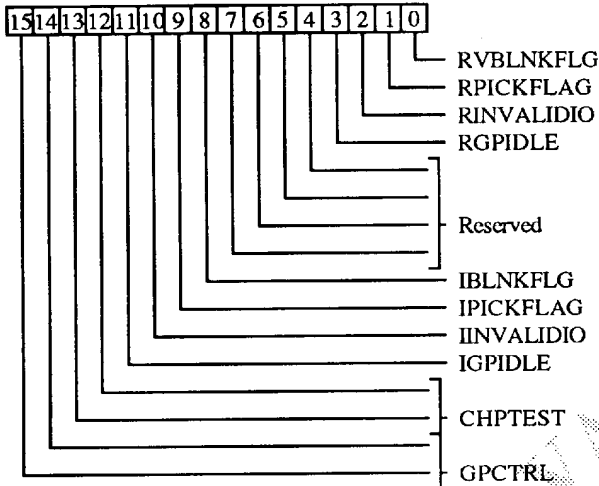

3-0 Interrupt Reset. These bits are used to reset active interrupt flags. They may be reset individually or in combination.

- 0 = Don't reset flag
- 1 = Reset flag

The reset bits are as follows:

- 0** RVBLNKFLG Reset Vertical Blank Flag
- 1** RPICKFLAG Reset PICK Flag
- 2** RINVALIDIO Reset Queue overflow / Data underflow flag
- 3** RGPIDLE Reset Graphics Engine Idle flag

Note: Bits 3:0 always read back = 0.

7-4 Reserved (0)

11-8 Interrupt Enables. These bits are used to permit a particular interrupt condition to generate an external IRQ.

- 0 = Disable interrupts for this condition
- 1 = Enable interrupts for this condition

- 8** IBLNKFLG Enable Vertical Blank interrupt
- 9** IPICKFLAG Enable PICK interrupt
- 10** IINVALIDIO Enable Queue Overflow / Data Underflow interrupt
- 11** IGPIDLE Enable Graphics Engine Idle interrupt

13-12 CHPTST Program to 01 to enable normal function.

On read back, bit 13 = 1 if 13:12 were programmed to 1x; otherwise = 0. On reset, initialized to 0 (Normal Operation). Bit 12 always reads back as 0.

15-14 GPCTRL Graphics Processor Control

15 14 Effect on 82C481

0	0	No effect
0	1	Enable Chip
1	0	Reset Chip. Stop all VRAM cycles, flush queue, clear GPBUSY and Queue Status flags. Don't reset counters or tristate pins.
1	1	Reset Chip. Stop all VRAM cycles, flush queue, clear GPBUSY and Queue Status flags. Don't reset counters or tristate pins. (Same as 1 0).

Bits 15:14 control an R-S type latch. The status of this software reset latch is read back in bit 15; bit 14 = 0.

On reset bit D15 = 0 (enabled).

Note: If the bus interface is UISA and pin 45 is connected to 0WS- on the AT bus, then EC1[8] should be set. This disables the generation of hardware interrupts to the system.



**ROM PAGE SELECT REGISTER
(ROM PAGE SEL)**

Read at I/O Address 46E8h (Chips Extension)

Write at I/O Address 46E8h

Byte or Word Accessible

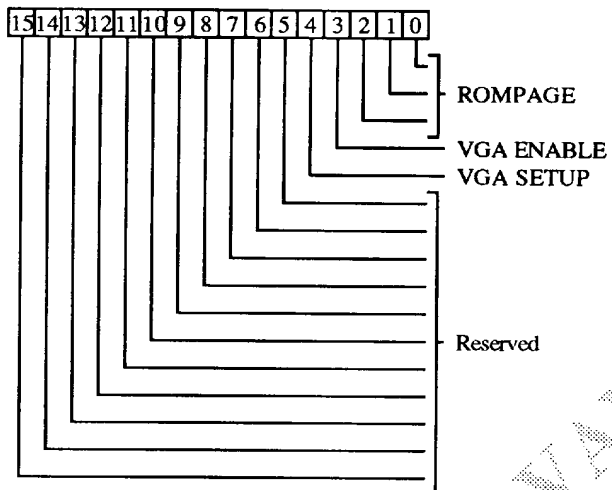

from occurring, we suggest the ROM (if installed) be relocated to another address range using the ROM relocation bits in Extended Configuration Register EC3. EC3 also contains bits to disable ROM paging and to select the size of the ROM address space.

3 VGA ENABLE This bit is not physically present on the 82C481, but is standard on ISA VGA cards. It is included here for completeness.

0 = Disable VGA
1 = Enable VGA

4 VGA SETUP This bit is not physically present on an 82C481 card but is standard on ISA VGA cards. It is included here for completeness.

0 = Normal operation
1 = Setup mode

15-5 Reserved (0)

2-0 ROMPAGE. ROMPAGE allows mapping one of 8 different 4K pages of on-board ROM to the same 4K memory in address space.

When implementing a ROM for an 82C481 design, it would be desirable to occupy a similar address range as does the IBM 8514/A adapter. Unfortunately, all of the standard IBM 8514/A address ranges except CA000h-CA7FFh conflict with most extended VGA BIOS. To prevent a conflict

ISA Bus Address (20-bit)	MC Bus Address (24-bit)	ROMPAGE 2 1 0	32K x 8 ROM Address	Comments
C6800-C6FFF	0C6800-0C6FFF	x x x	7800-7FFF	Fixed ROM
C7000-C7FFF	0C7000-0C7FFF	0 0 0	0000-0FFF	Paged ROM
C7000-C7FFF	0C7000-0C7FFF	0 0 1	1000-1FFF	Paged ROM
C7000-C7FFF	0C7000-0C7FFF	0 1 0	2000-2FFF	Paged ROM
C7000-C7FFF	0C7000-0C7FFF	0 1 1	3000-3FFF	Paged ROM
C7000-C7FFF	0C7000-0C7FFF	1 0 0	4000-4FFF	Paged ROM
C7000-C7FFF	0C7000-0C7FFF	1 0 1	5000-5FFF	Paged ROM
C7000-C7FFF	0C7000-0C7FFF	1 1 0	6000-6FFF	Paged ROM
C7000-C7FFF	0C7000-0C7FFF	1 1 1	7000-7FFF	Paged ROM
CA000-CA7FF	0CA000-0CA7FF	x x x	7000-77FF	Fixed ROM

IBM 8514/A Standard ROM Address Mapping



ADVANCED FUNCTION CONTROL REGISTER (ADVFUNC_CNTL)

Read at I/O Address 4AE8h (Chips Extension)
 Write at I/O Address 4AE8h
 Byte or Word Accessible

Alternate Video Register sets are an 82C481 extension of the 8514/A standard. They are used to support alternate display timing parameters (eg. 1024 x 768 non-interlaced) transparently to the software when running IBM 8514/A compatible code.

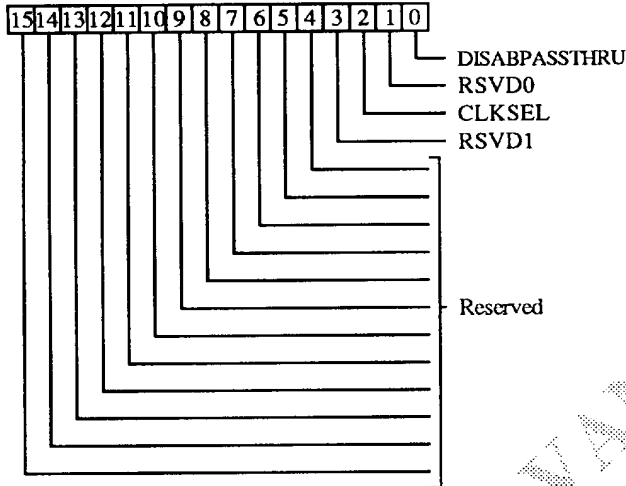

- 3 RSDV1 Reserved bit 1 = 0
- 15-4 Reserved (0)

WARNING: All write accesses to this register will clear the Alternate Register Set OVERRIDE bit (EC3[12]). This means that a non-standard resolution driver must rewrite register EC3 each time a write to ADVFUNC_CNTL is performed.

- 0 DISABPASSTHRU This bit controls the VGA pass-through feature of the 82C481.
 - 0 = VGA video is passed through the 82C481 RAMDAC to the display.
 - 1 = Advanced Function. 82C481 video is passed through the RAMDAC to the display.
- 1 RSDV0 Reserved bit 0 = 1
- 2 CLKSEL (Clock Select) This clock select bit is one of three supported by the 82C481. For backwards compatibility to the 8514/A standard CLKSEL0 appears here. The IBM 8514/A supports only two clock frequencies; 0 = 25.175MHz (640 x 480), and 1 = 44.900MHz (1024 x 768 interlaced). The 82C481 supports 8 clock frequencies through its extended clock select bits in register EC3. This CLKSEL0 bit in ADVFUNC_CNTL, along with a second CLKSEL0 bit in EC3[8], controls the selection of the alternate video register sets if they are enabled. The active CLKSEL0 data is that written during the last write to one of these two locations. EC3[8] always reads back the current status of the active CLKSEL0 bit (ie. from a write to either ADVFUNC_CNTL or EC3) whereas ADVFUNC_CNTL reads back the last data written to it.



EXTENDED CONFIGURATION REGISTER 0 (EC0)

Read at I/O Address 52E8h (Chips Extension)
Write at I/O Address 52E8h (Chips Extension)
Byte or Word Accessible

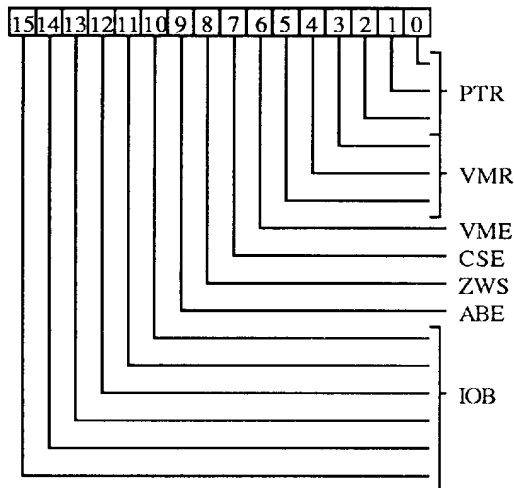

2-0 PTR PIX_TRANS Memory Mapped Range. The PIX_TRANS register may be memory mapped for faster system to screen transfers. Any memory accesses in the activated range will be interpreted as a read/write to the PIX_TRANS I/O register.

PTR			Address Range
2	1	0	
X	X	1	0A0000-0AFFFF (64K)
X	1	X	0B0000-0B7FFF (32K)
1	X	X	0B8000-0BFFFF (32K)
0	0	0	Disabled (Default)

Note: This memory mapping scheme is only advantageous if Zero Wait State (ZWS) and 16-bit accesses (VMR) are enabled.

5-3 VMR Video Memory Range for MEMCS16/ decode. An unlatched address decode will generate MEMCS16/ for each range:

VMR			Address Range
5	4	3	
X	X	1	0A0000-0AFFFF (64K)
X	1	X	0B0000-0B7FFF (32K)
1	X	X	0B8000-0BFFFF (32K)
0	0	0	Disabled (Default)

Warning: Whenever accessing any of the Extended Configuration registers, always preserve the state of the reserved bits. These reserved bits may be defined for special function control in the future.

6 VME VGA Memory command Enable. If set, VMEMR/ and VMEMW/ signals will be generated for accesses to the 0A0000-0BFFFF range and output instead of CSEL1:0 on pins 96, and 97.

- 0 = Clock Select data (Default)
- 1 = VMEMR/ and VMEMW/

7 CSE Clock Select Enable. Enables output on pins 96, and 97 when in UISA system bus interface mode. In all other bus interface modes (ISA, and Microchannel) this bit has no effect.

- 0 = Pins 96, and 97 Tri-state (Default)
- 1 = Output Enabled

8 ZWS Zero Wait State Enable. This bit enables the open collector 0WS pin for the video memory ranges selected by PTR2:0.

- 0 = Disabled (Default)
- 1 = 0WS enabled

Note: If your hardware implementation has this pin connected to the AT Bus 0WS signal, then this bit should be set during the boot sequence to avoid accidental enabling of an interrupt.

9 ABE Alternate Blank Enable. This bit enables writing to the alternate blank (overscan) registers (32E8-3AE8h).

- 0 = 3xE8h registers not accessible (Default)
- 1 = Alternate Blank registers writeable at 3xE8h

15-10 IOB I/O Base Address for all non-VGA decoded registers. These 6 bits are compared with address lines A9:A4 to determine an I/O address access. The default is 101110b (xxxx xx10 1110 1xxx = 2E8-2EF). Due to the possible conflict with ArcNet network cards mapping at 2E8h, the 82C481 is reconfigurable to another I/O space. A single I/O write to x2E8h should not conflict with an ArcNet card if the I/O write occurs before the ArcNet initialization (ie. before its device drivers are executed). All VGA cards perform I/O accesses to 46E8h during the boot process and this has no permanent effect on these cards.



EXTENDED CONFIGURATION REGISTER 1 (EC1)

Read at I/O Address 56E8h (Chips Extension)
Write at I/O Address 56E8h (Chips Extension)
Byte or Word Accessible

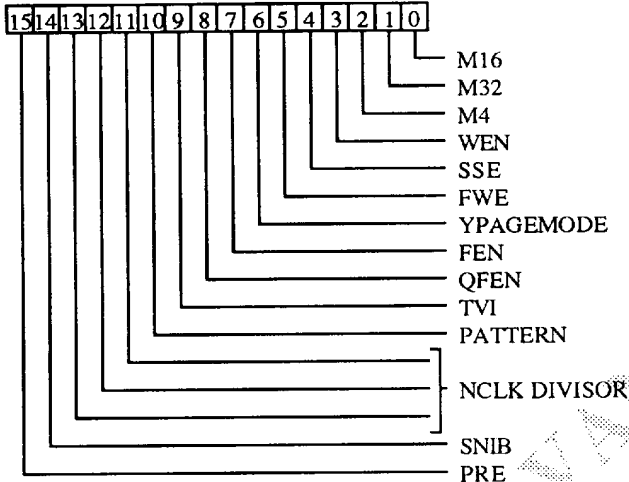

- 0 M16 16-plane Pixel Depth.
0 = Normal Operation
1 = 16bpp Operation
The 82C481 drawing engine supports a subset of its drawing operations in 16bpp mode. These are described in detail in the High Color Drawing section of the Functional Description.
- 1 M32 32-plane Pixel Depth.
0 = Normal Operation
1 = 32bpp Operation
The 82C481 drawing engine supports a subset of its drawing operations in 32bpp mode. These are described in detail in the High Color Drawing section of the Functional Description. This setting is also used for 24bpp modes.
- 2 M4 4-plane Pixel Depth.
0 = Normal Operation
1 = Nibble Mode Enabled
The 82C481 drawing engine supports a 4bpp mode when only 1MByte of memory is installed (8 256Kx4 VRAMs only). This bit enables alternate definitions of the

WE3A:0A and CAS01/ pins. This permits display and drawing functions into a 2048 x 1024 x 4bpp frame buffer.

- 3 WEN WE3A:0A/ and CAS01/ Enable. This bit is latched on reset as the inverted value of pin 104.
0 = 82C480 Compatible Operation
1 = WE3A:0A/, CAS01/ Enabled

When in 8bpp (normal) mode, WE3A:0A/ mirror WE3:0/ respectively. In nibble mode (M4 = 1), each WE signal operates independently. In high color (16,24,and 32bpp) modes, combinations of WE signals operate in parallel.

WEN	M4	WE0A/ WE3A:1A/	CAS01/
0	X	Z	P4D2:0
1	0	WE0	WE3:1
1	1	Nibble WE's	CAS1/

- 4 SSE Static Status Enable. There are 4 pins which multiplex information required by the 82B484 support chip. They are CSEL2:0, and AF. For designs not using an 82B484, the VRAM bank access information may not be needed. Therefore it is possible to disable the multiplexing, leaving the clock select status and AF permanently on these pins. This eliminates the need to use an external latch if only these signals are required.
0 = Normal Operation (Default)
1 = Static Operation
- 5 FWE Flash Write Support Enable. The FWE pin is always driven low after reset. This bit in combination with CRS and FWS bits of the MEM_CTRL register are used to perform Flash Write VRAM special cycles (Flash Write or Color Register Set).
0 = FWE pin forced low
1 = VRAM Special Cycles Enabled
- 6 YPAGEMODE In frame buffer configurations where there is more than one scan line per row address this bit should be set. It enables page mode cycles to occur when the y-ordinate changes but not the row address.
0 = Y page mode disabled (default)
1 = Y page mode cycles enabled
- 7 FEN Frame Status Enable. External devices

Warning: Whenever accessing any of the Extended Configuration registers, always preserve the state of the reserved bits. These reserved bits may be defined for special function control in the future.



implementing a hardware cursor need to know which frame is active when displaying interlaced modes. FRAME, pin 104, provides this information.

- 0 = FRAME tristate (default)
- 1 = FRAME enabled (0=even, 1=odd)

8 QFEN Queue Full Enable. Implementations which cache a display list require a simple method for detecting space in the 82C481 queue. QF, pin 71, provides this information in ISA modes only.

- 0 = QF tristate (default)
- 1 = QF enabled (0 = not full, 1 = full)

9 TVI Tristate VRAM Interface. External devices needing to access the frame buffer directly may tri-state the VRAM address, data, and control signals.

- 0 = VRAM interface enabled (default)
- 1 = VRAM interface disabled

10 PATTERN Enables the 8x8 bit pattern register and substitutes it for the standard 8 bit pattern. For pattern usage see the PATTERN_L register (MFC{8}).

- 0 = Use PAT_L, PAT_H (default)
- 1 = Use extended 8 x 8 pattern

13-11 NCLK DIVISOR In designs not using the 82B484, a synchronous 1/8 PCLK signal may not be available. All timing for the 82C480 is generated internally based on the NCLK input directly. For compatibility, the 82C481 expects to have a 1/8 PCLK signal input. The 82C481 additionally has the

ability to prescale the NCLK input so that the CRT controller receives a 1/8 PCLK. The prescale options are:

EC1			Prescale	Usage
12	11	10	Divisor	
0	0	0	1	4bpp (default)
0	0	1	2	8bpp
0	1	1	4	16bpp
1	1	1	8	32bpp

All other combinations are illegal and may result in stopping the internal CRT nudget clock. Register bits EC1[12:10] are cleared on reset. The RAMDAC serial data "load clock" may be connected directly to the NCLK input of the 82C481. This register must be set to restrict the internal 8-pixel clock to less than 32MHz. (Max NCLK frequency = 40MHz)

14 SNIB Swap Nibble. The Bt484/Bt485 RAMDACs reverse the order of the nibbles in 8:1 multiplexing mode. The 82C481 can internally swap its nibbles to arrange the data in the VRAMs correctly. When in 4bpp mode (M4=1) the pixel data is organized as shown in the table below.

- 0 = Normal Ordering
- 1 = Bt484/Bt485 Swap Nibble order

15 PRE Palette Read Enable

- 0 = VGA Palette Reads Disabled (Default)
- 1 = VGA Palette Reads Enabled

RAMDAC Pixel Port	82C481 Data Port	82C481 Internal Data Path (TLC34075) (Bt484/Bt485)		External VRAM Interface		
		SNIB = 0	SNIB = 1	Write Enable SNIB = 0	SNIB = 1	CAS SNIB = X
P(A)	P0D3:0	SD3:0	SD7:4	WE0/	WE0A/	CAS0/
P(B)	P0D7:4	SD7:4	SD3:0	WE0A/	WE0/	CAS0/
P(C)	P1D3:0	SD11:8	SD15:12	WE1/	WE1A/	CAS0/
P(D)	P1D7:4	SD15:12	SD11:8	WE1A/	WE1/	CAS0/
P(E)	P2D3:0	SD19:16	SD23:20	WE2/	WE2A/	CAS01/
P(F)	P2D7:4	SD23:20	SD19:16	WE2A/	WE2/	CAS01/
P(G)	P3D3:0	SD27:24	SD31:28	WE3/	WE3A/	CAS01/
P(H)	P3D7:4	SD31:28	SD27:24	WE3A/	WE3/	CAS01/

Data Path in 8:1 4bpp Mode (M4 = 1)

Note: The board routing for signals WE3:0 and WE3A:0A is dependent upon the 8:1 MUX data organization of the RAMDAC used.



T-52-33-45

EXTENDED CONFIGURATION REGISTER 2 (EC2)

Read at I/O Address 5AE8h (Chips Extension)
Write at I/O Address 5AE8h (Chips Extension)
Byte or Word Accessible

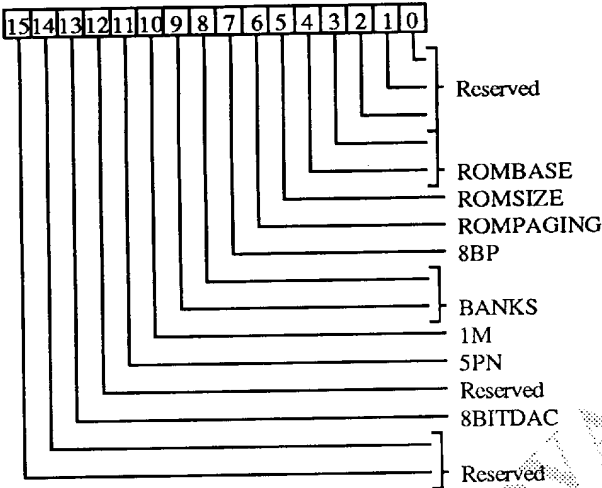

- 2-0 Reserved = 1. These bits are latched on reset from P4D2:0 and as yet have no defined usage. They each have internal pull-up resistors so they default to 1.
- 4-3 ROMBASE ROM Base defines the start of the 82C481 ROM address space in system memory (default = 11). These bits are latched on reset from P4D4:3. ROM address mapping is also dependant on ROMSIZE (below) and the type of system interface.

EC2		8K		32K	
[4]	[3]	MC	ISA	MC	ISA
0	0	0C8000	C6000	0D0000	D0000
0	1	0D8000	D8000	0D8000	D8000
1	0	0C0000	C0000	0C0000	C0000
1	1	0C6000	C8000	0C8000	C8000

ROM page 0 always maps to the first 4K of address space.

Note: The VGA ROM takes up 32K bytes at C0000-C7FFFh which conflicts with the space used by the MC bus 8514/A (C6000-C7FFFh). Also, CA000h as used

by IBM conflicts with other cards in typical ISA bus systems. For this reason, it is recommended that the ROM space in 481-based systems be configured for the default addresses: C6000-C7FFFh in MC and C8000-C9FFFh in the ISA bus. For specific ROM mapping tables consult the tables on the following page.

- 5 ROMSIZE Indicates the size of the address space allocated in memory (starting at the base address indicated by ROMBASE above).
 - 0 = 32K ROM address space
 - 1 = 8K ROM address space (default)
 This bit is latched on reset from P4D5.

If a 32K physical ROM is implemented in an 8K address space, then the ROMPG2:0 pins should be connected to ROM address inputs A14:12. The upper 4K of the ROM space may then be paged from any one of the eight 4K pages in the ROM. This is done via the ROM_PAGE_SEL register. If an 8K physical ROM is connected, ROMSIZE should be selected as 8K and ROMPG2:0 do not need to be connected. These bits may then be used as general purpose outputs or may be selected by the ROM PAGING bit as transparent inputs for the MONITOR_ID bits.

- 6 ROMPAGING This bit is latched on reset from P4D6.
 - 0 = ROMPG pins are inputs
 - 1 = ROMPG pins are outputs

If ROMPAGING = 1, after latching the MONITOR_ID data on reset, the ROMPG pins then become outputs. If ROMSIZE is also latched low on reset, then ROMPG pins always output the contents of ROM_PG_SEL[2:0]. If ROMSIZE = 1, then ROMPG pins output either address or ROM_PG_SEL[2:0] as demonstrated in the paging table on the following page.

If ROMPAGING = 0, then the ROMPG pins become transparent inputs readable at SUBSYS_STAT[6:4]. This allows the detection of a monitor which was connected after power was switched on.

Warning: Whenever accessing any of the Extended Configuration registers, always preserve the state of the reserved bits. These reserved bits may be defined for special function control in the future.



T-52-33-45

- 7 8BP (8 Bit Planes). This bit is a copy of the read-only 8PLANE bit in SUBSYS_STAT[7]. It is latched from P4D7 on reset. Configuration drivers written specifically for the 82C481 may write this bit, eliminating the need for a jumper.
 - 0 = 4-bit planes
 - 1 = 8-bit planes (default)
- 9-8 BANKS Indicates the number of VRAM banks connected to the 82C481.
 - 00 = 1 bank
 - 01 = 2 banks
 - 10 = 3 banks
 - 11 = 4 banks (default)

These bits are latched from pins CAS3/ and CAS2/ on reset. When BANKS = 01 or 11, the data is always horizontally interleaved.
- 10 1MB Indicates type of VRAMs used:
 - 0 = 64Kx4
 - 1 = 256Kx4 (default)

This bit is latched from MA8 on reset.
- 11 5PN 5-Pixel Nuggets. This bit is latched from WE4/ on reset. It determines whether the VRAM bank configuration is 4 or 5 pixels deep. It is necessary to program MEM_CNTL[0] = 1 in order to set the 82C481 into 5-pixel nugget mode.
- 12 Reserved (0)
- 13 8BITDAC 8-Bit DAC Control. Latched from 8BITDAC on reset.
 - 0 = 6-bit
 - 1 = 8-bit
- 15-14 Reserved (0)

Note: The 82C481 mapping table shown below demonstrates the address space mapping for a default 481 MCA configuration. Paging in the C7000-C7FFFh range is chosen by n=ROM_PAGE_SEL[2:0]. The value of 'n' is determined by the ROMPAGING bits. '0L' refers to the lower 4KB of the 8KB ROM page 0; '0H' refers to the upper 4KB of that page.

System Address	IBM MCA 8514/A ROM Address	481 MCA 8K ROM Address	ROM Page
C6000-C67FF	N/A	0000-07FF	0L
C6800-C6FFF	7800-7FFF	0800-0FFF	7H/0H
C7000-C7FFF	n000-nFFF	n000-nFFF	n
CA000-CA7FF	7000-77FF	N/A	7L

8514/A and 481 ROM Map (MC Bus)

System Address	IBM ISA VGA ROM Address	Typical ISA VGA ROM Address	ROM Page
C0000-C5FFF	0-5FFF	0000-5FFF	0-5
C6000-C67FF	N/A	6000-67FF	6L
C6800-C6FFF	7800-7FFF	6800-6FFF	7H/6H
C7000-C7FFF	n000-nFFF	7000-7FFF	n / 7
CA000-CA7FF	7000-77FF	N/A	7L

VGA ROM Map (ISA Bus)



EXTENDED CONFIGURATION REGISTER 3 (EC3)

Read at I/O Address 5EE8h (Chips Extension)

Write at I/O Address 5EE8h (Chips Extension)

Byte or Word Accessible

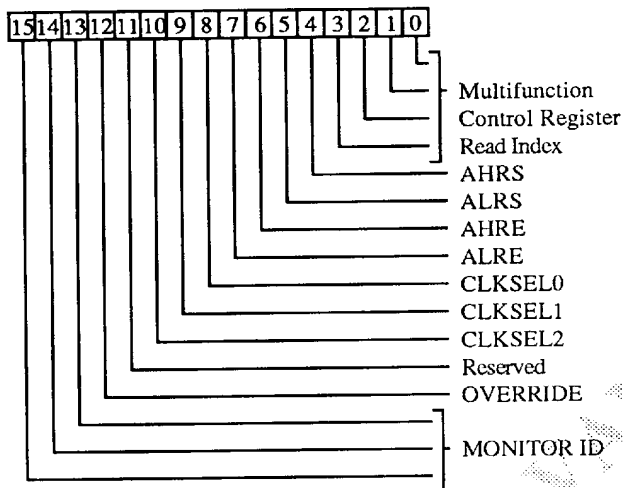

3-0 Multifunction Control Register Read Index. These bits indicate which of the Multifunction Control [MFC] index registers will be read by a read access to BEE8h. When a read is performed at BEE8h, the index bits [15:12] are undefined.

4 AHRS Alternate High Register Select. This bit controls write access to the Alternate High group of Video Timing Parameter Registers.

- 0 = Not selected (default)
- 1 = Selected

This bit is set to initialize the High-Resolution video parameters (1024 x 768). This would generally only be done once following power-up under the control of the BIOS or a device driver. It may be used to customize the video timing for a specific country or monitor type (eg. non-interlaced vs. interlaced).

Warning: This bit redirects write accesses to the alternate high registers. Enabling select bits AHRS and ALRS simultaneously disables all accesses. Leave this bit clear for normal operation. Standard 8514 applications should write to the normal registers.

5 ALRS Alternate Low Register Select. This bit controls write access to the Alternate Low group of Video Timing Parameter Registers.

- 0 = Not selected (default)
- 1 = Selected

This bit is set to initialize the Low-Resolution video parameters (640 x 480). This would generally only be done once following power-up under the control of the BIOS or device driver. It may be used to customize the video timing for a specific country or monitor type (eg. 72Hz. refresh).

Warning: This bit redirects write accesses to the alternate low registers. Enabling select bits AHRS and ALRS simultaneously disables all accesses. Leave this bit clear for normal operation. Standard 8514 applications should write to the normal registers.

6 AHRE Alternate High Register Enable. This bit enables the alternate High-resolution video timing register set. When this bit is set, a write to the ADVFUNC_CNTL register with CLKSEL0=1, will select the alternate high registers for use when generating video.

- 0 = Use normal video registers (default)
- 1 = Use Alternate High video registers

7 ALRE Alternate Low Register Enable. This bit enables the alternate Low-resolution video timing register set. When this bit is set, a write to the ADVFUNC_CNTL register with CLKSEL0=0, will select the alternate low registers for use when generating video.

- 0 = Use normal video registers (default)
- 1 = Use Alternate Low video registers

10-8 CLKSEL2:0 Clock Select 2-0. There are three sets of Clock Select bits maintained internally by the 481. One set each for Alternate High, Alternate Low, and normal video register sets. When one of the Alternate Register Select bits is set, then the CLKSEL bits corresponding to that alternate set is visible (read/write) at this location. The default on reset is the normal set. The CLKSEL0 bit of the normal video register set is always write accessible in the ADVFUNC_CNTL register.

11 Reserved (0)

Warning: All writes to this register should be 8-bit. Due to the nature of the control bits in the lower byte, simultaneous writes to the alternate CLKSEL bits would be indeterminate.



12 OVERRIDE (default = 1)

- 0 = Do not override AHRE, ALRE
- 1 = Force normal video register set

This bit allows an 82C481 custom driver to force the 481 to use the normal video register set. That is, it overrides the Alternate Register Enable bits since it is using a video mode other than 640 x 480 or 1024 x 768.

This bit is reset on any write to the ADVFUNC_CNTL register. This is necessary to avoid improper recovery when a non-standard exit from an application driver occurs. The 481 must always force an unsuspecting program (not a CHIPS 481 driver) to use the Alternate Video Register Set if one is enabled.

The implications of this reset is that if a high resolution device driver which uses OVERRIDE should need to write ADVFUNC_CNTL, then it must immediately write EC3 to again override the Alternate Register Enable bits.

15-13 MONITOR ID If the MONITOR ID bits of the SUBSYS_STAT register are latched on reset (ROMPAGING = 1) then the latched data may be modified by writing to EC3[15:13]. If ROMPAGING = 0 then the ROMPG2:0 pins are read transparently at SUBSYS_STAT[6:4]. Writing these bits has no effect on the data read in the SUBSYS_STAT register. The data read at this location is the same data that is read at SUBSYS_STAT[6:4]. Hence, if ROMPAGING = 0, the data read back at this location is not necessarily the data which was written.

CURRENT Y POSITION REGISTER (CUR_Y)

Read at I/O Address 82E8h
Write at I/O Address 82E8h
Byte or Word Accessible

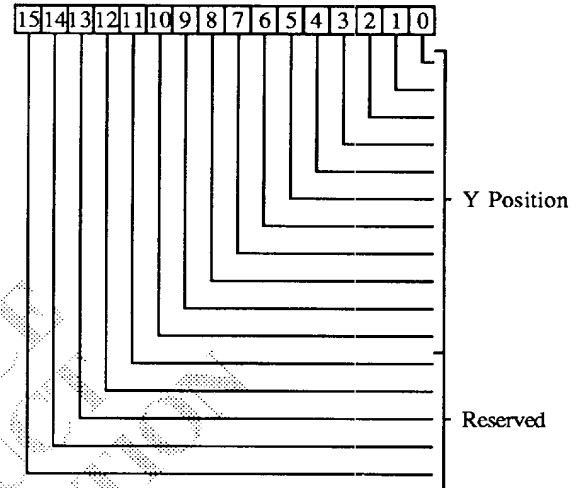

11-0 Y Position = Y coordinate of current position (in pixels). The XY position is relative to the top left corner of the display. Each scan line displays X-coordinates 0 through XMAX - 1. Each screen displays Y-coordinates 0 through YMAX - 1.

15-12 Reserved (0)



**CURRENT X POSITION REGISTER
(CUR_X)**

Read at I/O Address 86E8h
Write at I/O Address 86E8h
Byte or Word Accessible

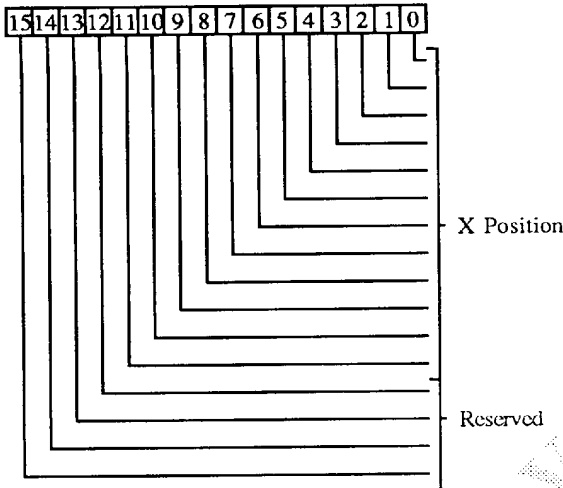

**DESTINATION Y POSITION REGISTER
AXIAL STEP CONSTANT REGISTER
(DESTY_AXSTP)**

Read at I/O Address 8AE8h (Chips Extension)
Write at I/O Address 8AE8h
Byte or Word Accessible

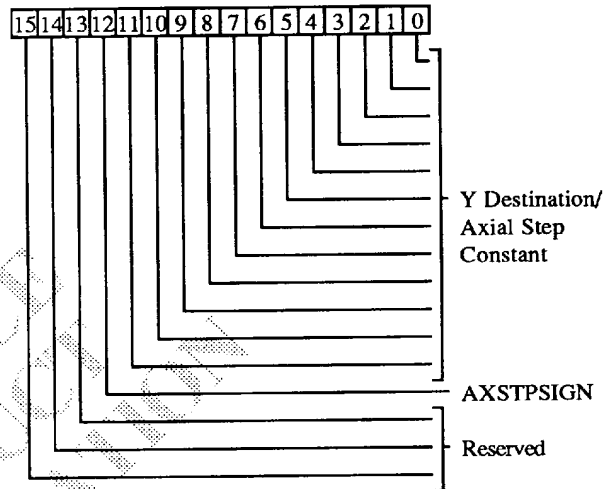

11-0 X Position = X coordinate of current position (in pixels). The XY position is relative to the top left corner of the display. Each scan line displays X-coordinates 0 through XMAX - 1. Each screen displays Y-coordinates 0 through YMAX - 1.

Warning: In 5PN mode, bits 11, 1 and 0 are remainder bits; 10:2 are the current X position modulus 5.

15-12 Reserved (0)

11-0 Y-Destination. During BITBLT operations this register is programmed to the destination Y address (measured in pixels).

11-0 Axial Step Constant. During line drawing, this register is programmed as the Bresenham constant $2 \cdot d_{minor}$ (d_{minor} is the length of the line projected onto the minor or dependant axis).

12 AXSTPSIGN Sign flag for Axial Step Constant (should be set to 0 during BITBLT operations).

15-13 Reserved (0)



**DESTINATION X POSITION REGISTER
DIAGONAL STEP CONSTANT REGISTER
(DESTX_DIASTP)**
Read at I/O Address 8EE8h (Chips Extension)
Write at I/O Address 8EE8h
Byte or Word Accessible

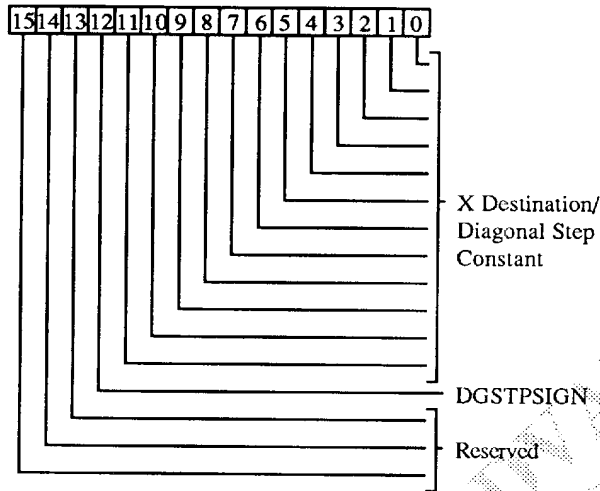

**ERROR TERM REGISTER
(ERR_TERM)**
Read at I/O Address 92E8h
Write at I/O Address 92E8h
Byte or Word Accessible

T-52-33-45

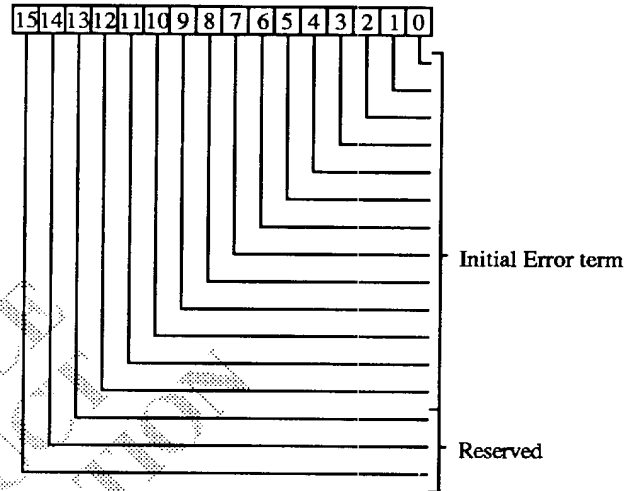

- 11-0 X-Destination. During BITBLT operations this register is programmed to the destination X address (measured in pixels).
- 11-0 Diagonal Step Constant. During line drawing, this register is programmed as the Bresenham constant $2 \cdot d_{\text{minor}} - 2 \cdot d_{\text{major}}$ (d_{minor} is the length of the line projected onto the minor or dependant axis; d_{major} is the length of the line projected onto the major or independent axis).
- 12 DGSTPSIGN Sign flag for Diagonal Step Constant (should be set to 0 for BITBLT operations).
- 15-13 Reserved (0)

- 12-0 Initial Error Term. This register is programmed to the Bresenham initial error term before a line drawing command is issued. Its initial value is set to $2 \cdot d_{\text{minor}} - d_{\text{major}}$ (d_{minor} is the length of the line projected onto the minor or dependant axis; d_{major} is the length of the line projected onto the major or independent axis). During the line draw, this register holds the current state of the error term. When bit 12=1, it causes the Bresenham logic to increment the dependant axis (make a diagonal step).
- 15-13 Reserved (R/W)
These bits are read/write but do not participate in the calculation of the error term.



T-52-33-45

**MAJOR AXIS PIXEL COUNT REGISTER
RECTANGLE WIDTH REGISTER
(MAJ_AXIS_PCNT)**

Read at I/O Address 96E8h (Chips Extension)
Write at I/O Address 96E8h
Byte or Word Accessible

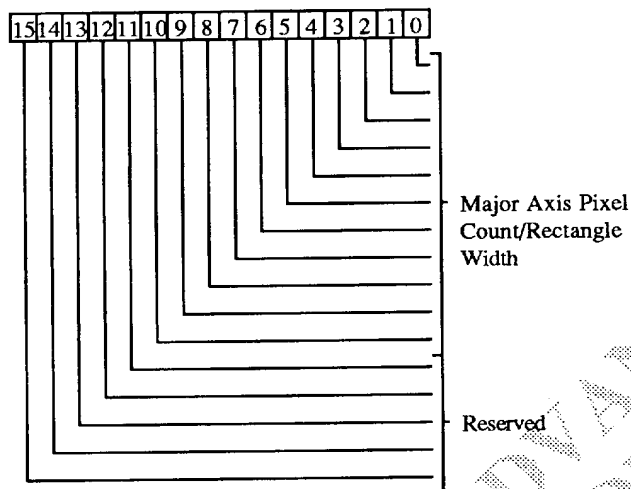

10-0 Major Axis Pixel Count holds the constant term $dmajor$ for Bresenham line drawing ($dmajor$ is the length of the projection of the line to be drawn along the independent axis). This must be a positive number. The programmed value should be:

$$\text{Major Axis Pixel Count} = dmajor - 1$$

10-0 Rectangle Width holds the width of the rectangle (in pixels) for BITBLT and rectangle drawing commands. The programmed value should be:

$$\text{Rectangle Width} = \text{Actual Width} - 1$$

15-11 Reserved (0)



GRAPHICS PROCESSOR STATUS REGISTER (GP_STAT)

Read at I/O Address 9AE8h
Byte or Word Accessible

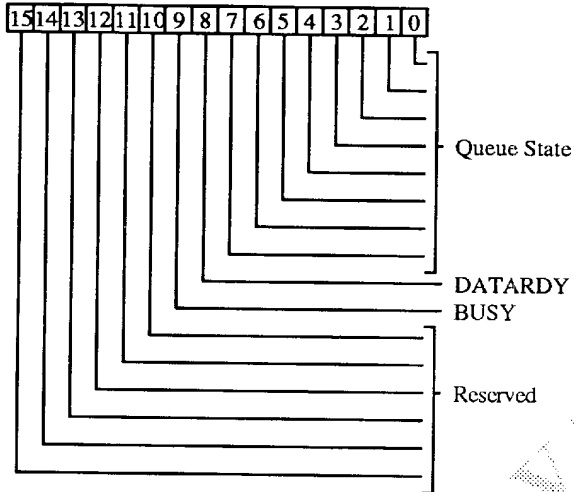

7-0 Queue State indicates the number of positions available in the queue. The standard 8514/A command queue is eight words deep. The 82C481 has a 16 word deep queue. Queue State is nicknamed the thermometer register. It shows the number of bytes available encoded linearly. Queue State = 0 if the queue is empty. In the 82C481, Queue State = 1 if there are at least 7 spaces available in the queue (there may be as many as 15). Always test BUSY to determine if the drawing engine is idle.

Queue State
76543210

- 00000000 = 16 words available
- 00000001 = 7-15 words available
- 00000011 = 6 words available
- 00000111 = 5 words available
- 00001111 = 4 words available
- 00011111 = 3 words available
- 00111111 = 2 words available
- 01111111 = 1 word available
- 11111111 = 0 words available-queue full

Note: The 82C481 has a hardware status pin, QF, dedicated to the queue status. It may be used by tightly coupled processors to feed the 82C481 with long command lists. Refer to EC1[8] for more information.

8 DATARDY indicates availability of variable data from the PIX_TRANS register.

- 0 = No new data ready
- 1 = Data is ready to be read from the PIX_TRANS register. This will occur if a drawing command is executed with WRTDATA=0 and PCDATA=1. It indicates that the next pixel has been read from the display buffer and may be read from the PIX_TRANS register.

Note: If the CPU attempts to read PIX_TRANS and there is no data ready, then the 82C481 extends the read cycle with I/O CH RDY. If no data becomes available within 256 MCLK periods, then the 82C481 releases the bus and generates an internal INVALIDIO interrupt.

9 BUSY (Graphics Processor Busy)

- 0 = Not Busy
- 1 = Busy (currently executing a drawing command).

15-10 Reserved (0)



COMMAND REGISTER (CMD)

Write at I/O Address 9AE8h
Byte or Word Accessible

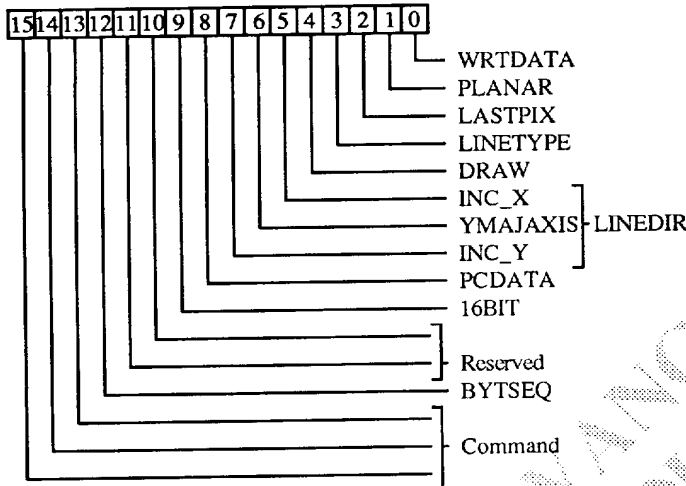

- 0 WRTDATA = Pixel write operation
 - 0 = Read operation (line, SSV, or rectangle commands). Commands execute normally except that no writes to memory are performed. This can be used with rectangle commands to copy rectangular blocks of the display bitmap into system memory.
 - 1 = Write operation. VRAM writes are enabled for drawing command.
- 1 PLANAR defines the orientation of the display bitmap for most drawing operations.
 - 0 = Through plane mode
 - 1 = Across plane mode
- 2 LASTPIX = Last Pixel Null
 - 0 = Last pixel is drawn
 - 1 = Last pixel is not drawn

Some rectangle drawing commands disregard this bit and force Across plane mode for increased speed. Reading in across planes mode is not supported in 16bpp, and 32bpp modes.

For line commands (CMD_LINE, SSV, or CMD_LINEAF) the current position (CUR_X, CUR_Y) is moved to the end of the line but the last pixel is not drawn. This

is used for those mixes (such as XOR) which would produce the wrong color if the same pixel were drawn twice (e.g. at the end of one polygon segment and at the start of the next segment).

For rectangles, this bit has different effects depending on which rectangle command is issued and also the state of the INC_X and INC_Y bits as listed below:

- CMD_RECT
 - INC_X = 0 Leftmost column not drawn
 - INC_X = 1 Rightmost column not drawn
- CMD_RECTV1
 - INC_Y = 0 Top row not drawn
 - INC_Y = 1 Bottom row not drawn
- CMD_RECTV2
 - No effect
- CMD_BITBLT
 - INC_X = 0 Leftmost column not drawn
 - INC_X = 1 Rightmost column not drawn

- 3 LINETYPE (Vector Enable).
 - 0 = Enable Bresenham line drawing
 - 1 = Enable vector line drawing

When vector line drawing is enabled (LINETYPE = 1) and a CMD_NOP issued, writes to the SHORT_STROKE register allow the specified vector to be drawn at the current position. When LINETYPE = 1, and a draw line command (CMD_LINE) is issued, a vector of length MAJ_AXIS_PCNT is drawn in the direction specified by LINEDIR. Lines drawn with LINETYPE = 1 are restricted to 45° angles. Lines of any slope may be drawn using the Bresenham drawing registers (LINETYPE = 0).
- 4 DRAW This bit is the equivalent of a pen up/pen down flag on a plotter.
 - 0 = Marking disabled for line and BitBlts. Current position is moved, but no pixels are modified.
 - 1 = Marking enabled.

Note: This bit should be set when attempting to read or write bitmap data.



- 5** **INC_X** (X positive) This bit along with INC_Y (below) determine which quadrant the slope of a line lies within. They also determine the orientation for rectangle draw commands. The upper left corner of the screen is the origin (x,y = 0,0).
- 0 = Lines are drawn in negative X direction (right to left).
 - 1 = Lines are drawn in positive X direction (left to right).
- 6** **YMAJAXIS** For Bresenham line drawing commands, this bit determines which axis is the independent or major axis. Bits INC_X, and INC_Y define which quadrant the slope falls within; this bit further defines the slope to within an octant.
- 0 = X is major (independent) axis.
 - 1 = Y is major (independent) axis.
- 7** **INC_Y** (Y positive) This bit along with INC_X (above) determine which quadrant the slope of a line lies within. They also determine the orientation for rectangle draw commands. The upper left corner of the screen is the origin (x,y = 0,0).
- 0 = Lines are drawn in the negative Y direction (up the screen).
 - 1 = Lines are drawn in the positive Y direction (down the screen).
- 7-5** **LINEDIR** When a line draw command (CMD_LINE) is issued with LINETYPE = 1, LINEDIR bits specify the angular direction in which the line is to be drawn (counterclockwise relative to the positive x-axis). The length of the line is determined by the MAJ_AXIS_PCNT register.
- | LINEDIR | Angular Direction |
|---------|-------------------|
| 0 0 0 | 000° |
| 0 0 1 | 045° |
| 0 1 0 | 090° |
| 0 1 1 | 135° |
| 1 0 0 | 180° |
| 1 0 1 | 225° |
| 1 1 0 | 270° |
| 1 1 1 | 315° |
- 8** **PCDATA** (Pixel Data Enable)
This bit is used to indicate that data is to be read/written through the PIX_TRANS register during the draw / SSV command.
- 0 = Pixel data transfer disabled

- 1 = Pixel data transfer enabled. The drawing engine waits for read/write of the PIX_TRANS register for each pixel during a draw operation. Depending on the foreground and background source select bits of the command issued, this data is not necessarily used in determining the actual pixel drawn.
- 9** **16BIT** 16-bit operation.
- 0 = PIX_TRANS register is accessed as an 8-bit register.
 - 1 = PIX_TRANS register is processed internally as two bytes in the order specified by BYTSEQ (below).
- Note: The IBM 8514/A does not handle 8-bit data transfer cycles properly to the PIX_TRANS register (IN AL,DX or OUT DX,AL). When developing programs which must execute on any IBM 8514/A or compatible, only 16-bit I/O operations should be performed (IN AX,DX or OUT DX,AX) to this register.*
- 11-10** Reserved (0)
- 12** **BYTSEQ** Byte Sequence affects both reads and writes of SHORT_STROKE and PIX_TRANS registers when 16BIT = 1.
- 0 = Take high byte first
 - 1 = Take low byte first
- 15-13** **CMD** Draw Command
- 111 = Illegal
 - 110 = CMD_BITBLT (Copy rectangle)
 - 101 = CMD_LINEAF (outline)
 - 100 = CMD_RECTV2 (Fast filled Y direction rectangle)
 - 011 = CMD_RECTV1 (Fill rectangle in Y direction)
 - 010 = CMD_RECT (Fill rectangle in X direction)
 - 001 = CMD_LINE
 - 000 = CMD_NOP (This should be used when drawing SSVs)
- Note: CMD_LINEAF and hardware fill commands do not function correctly in 16bpp and 32bpp modes.*



SHORT STROKE VECTOR TRANSFER REGISTER (SHORT STROKE)

Read at I/O Address 9EE8h (Chips Extension)

Write at I/O Address 9EE8h

Byte Accessible (16BIT=0)

Byte or Word Accessible (16BIT=1)

WARNING: The high byte of SHORT_STROKE must always be written in order for the command to execute. This means that if a byte write is performed to 9EE8h, it must be followed by a byte write to 9EE9h before the drawing engine will start. This register functions independent of the state of the 16BIT field in the CMD register.

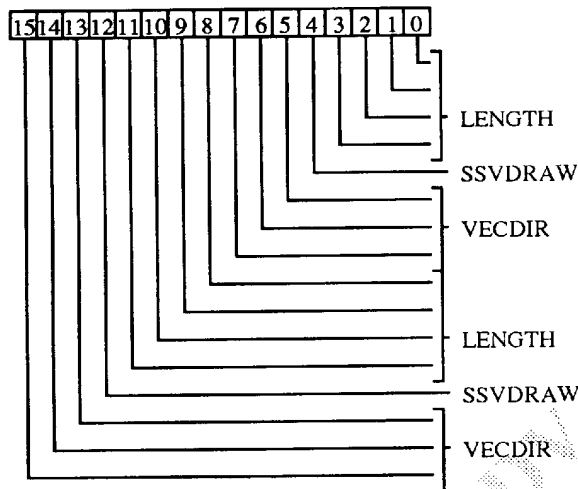

This is identical to the way in which the IBM 8514/A functions and is duplicated in the 82C481 for compatibility. The IBM Adapter Interface (AI) appears to always communicate with the 8514/A SHORT_STROKE register using 16-bit I/O instructions.

It is always possible to pad a single SSV instruction with a NUL byte. The drawing engine recognizes an SSV with LENGTH = 0 and SSVDRAW = 0 as a NOP.

3-0 LENGTH = Length of vector projected onto major axis (this is also the number of pixels drawn). The current position is always moved LENGTH pixels from its starting value. A LENGTH of 0 leaves the current position unchanged.

4 SSVDRAW
 0 = Don't write pixels
 1 = Write pixels

7-5 VECDIR Vector Direction indicates the angle (measured counter-clockwise from horizontal right) at which the line is drawn.

VECDIR	Angular Direction
0 0 0	000°
0 0 1	045°
0 1 0	090°
0 1 1	135°
1 0 0	180°
1 0 1	225°
1 1 0	270°
1 1 1	315°

15-8 The lower 8 bits are duplicated in the upper 8 bits of the register so that two SSV commands may be issued simultaneously. These vectors are then executed in the order specified by BYTSEQ (CMD[12]).



BACKGROUND COLOR REGISTER (BKGD_COLOR)

Write at I/O Address A2E8h
Byte or Word Accessible

There are separate modulo-n counters for all variable depth registers.

8-15 Reserved (0)

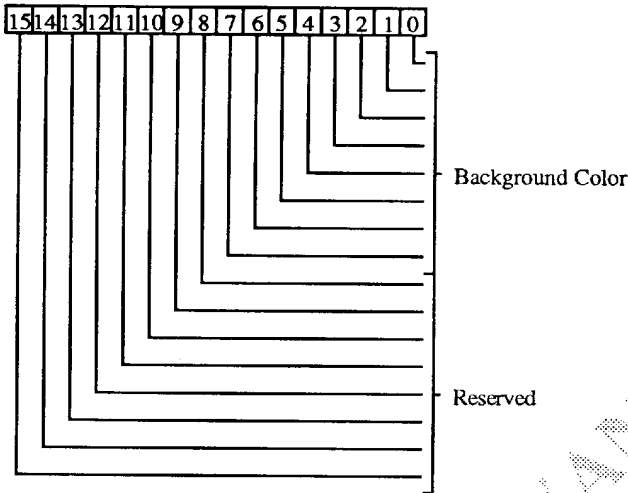

Warning: During drawing commands, A2E8h returns PIX_TRANS register data and performs as if a read were made to the PIX_TRANS register. This is required for IBM 8514/A compatibility.

The BKGD_COLOR register is writable at A2E8h whenever GPBUSY = DATARDY = 0 or when PCDATA = 0. Otherwise, during drawing commands with PCDATA = 1, a write to A2E8h functions as a write to the PIX_TRANS register.

7-0 Background Color. This is the color used for writing pixels where the Foreground Color Mix is selected and FSS=00, or the Background Color Mix is selected and BSS=00.

When in 16bpp mode the background color register is 16-bits deep. It is loaded as two consecutive 8-bit I/O writes to the BKGD_COLOR register. There is an internal modulo-2 counter to address the segments of the 16-bit color register correctly. The extended color register is mapped P(A), P(B). Any write to EC1, active command, hardware reset or software reset will clear the modulo-2 counter.

In 32bpp mode the background color register is 32-bits deep. Four I/O writes are required to write all 32-bits of this register. There is an internal modulo-4 counter to address the segments of the 32-bit color register correctly. The extended color register is mapped P(A), P(B), P(C), P(D). Any write to EC1, active command, hardware reset or software reset will clear the modulo-4 counter. This is useful for 24bpp modes in which only P(A), P(B), and P(C) are displayed. In this case, only 3 I/O writes are necessary. The modulo-4 counter will be reset when the associated command becomes active.



T-52-33-45

**FOREGROUND COLOR REGISTER
(FRGD_COLOR)**

Write at I/O Address A6E8h
Byte or Word Accessible

There are separate modulo-n counters for all variable depth registers.

8-15 Reserved (0)

Warning: During drawing commands, A6E8h returns PIX_TRANS register data and performs as if a read were made to the PIX_TRANS register. This is required for IBM compatibility.

The FRGD_COLOR register is writable at A6E8h whenever GPBUSY = DATARDY = 0 or when PCDATA = 0. Otherwise, during drawing commands with PCDATA = 1, a write to A6E8h functions as a write to the PIX_TRANS register.

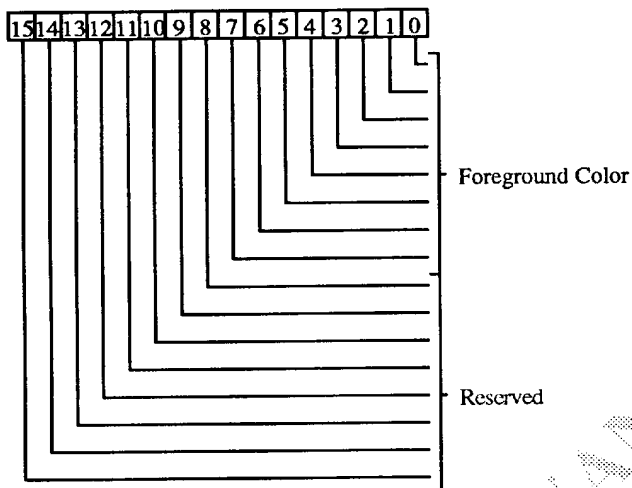

7-0 Foreground Color. This is the color used for writing pixels where the Foreground Color Mix is selected and FSS=01, or the Background Color Mix is selected and BSS=01.

When in 16bpp mode the foreground color register is 16-bits deep. It is loaded as two consecutive 8-bit I/O writes to the FRGD_COLOR register. There is an internal modulo-2 counter to address the segments of the 16-bit color register correctly. The extended color register is mapped P(A), P(B). Any write to EC1, active command, hardware reset or software reset will clear the modulo-2 counter.

In 32bpp mode the foreground color register is 32-bits deep. Four I/O writes are required to write all 32-bits of this register. There is an internal modulo-4 counter to address the segments of the 32-bit color register correctly. The extended color register is mapped P(A), P(B), P(C), P(D). Any write to EC1, active command, hardware reset or software reset will clear the modulo-4 counter. This is useful for 24bpp modes in which only P(A), P(B), and P(C) are displayed. In this case, only 3 I/O writes are necessary. The modulo-4 counter will be reset when the associated command becomes active.

**WRITE MASK REGISTER
(WRT_MASK)**

Read at I/O Address AAE8h (Chips Extension)

Write at I/O Address AAE8h

Byte or Word Accessible

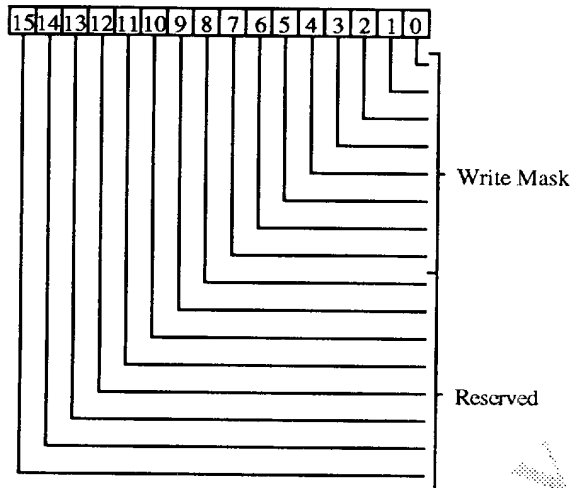

left untouched. The modulo-4 counter is then reset when the associated command becomes active.

There are separate modulo-n counters for all variable depth registers.

15-8 Reserved (0)

Note: WRT_MASK has some special functions during area fill operations. Refer to the discussion of the PLANEMODE bits with respect to area fill described in the Drawing Operations section of this manual.

Warning: Fill operations only function correctly in 4bpp and 8bpp modes. Performing a fill in 16bpp or 32bpp modes may produce undesirable results.

7-0 Write Mask is used to prevent data from being modified in specific planes.

- 0 = Disable modifying plane
- 1 = Enable modifying plane

The Write Mask is 8-bits deep in standard (8bpp) modes and in 4bpp modes.

When in 16bpp mode, the Write Mask is 16-bits deep. It is loaded as two consecutive 8-bit I/O writes to the WRT_MASK register. There is an internal modulo-2 counter to address the segments of the 16-bit Write Mask register correctly. The extended Write Mask register is mapped P(A), P(B). Any write to EC1, active command, hardware reset or software reset will clear the modulo-2 counter.

In 32bpp mode the Write Mask is 32-bits deep. Four I/O writes are required to write all 32-bits of this register. There is an internal modulo-4 counter to address the segments of the 32-bit Write Mask register correctly. The extended Write Mask register is mapped P(A), P(B), P(C), P(D). Any write to EC1, active command, hardware reset or software reset will clear the modulo-4 counter. This is useful for 24bpp modes in which only P(A), P(B), and P(C) are displayed. In this case, only 3 I/O writes are necessary. The fourth (P(D)) byte mask is



T-52-33-45

**READ MASK REGISTER
(RD_MASK)**

Read at I/O Address AEE8h (Chips Extension)
Write at I/O Address AEE8h
Byte or Word Accessible

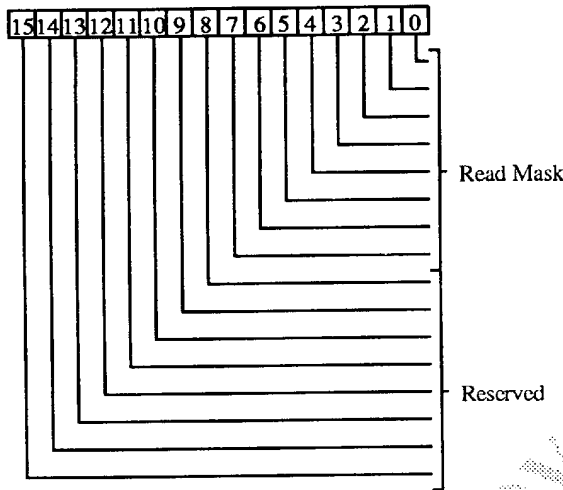

2 counter.

In 32bpp mode the Read Mask is 32-bits deep. Four I/O writes are required to write all 32-bits of this register. There is an internal modulo-4 counter to address the segments of the 32-bit Read Mask register correctly. The extended Read Mask register is mapped P(A), P(B), P(C), P(D). Any write to EC1, active command, hardware reset or software reset will clear the modulo-4 counter.

Only the P(A) Write Mask can be read back. There are separate modulo-n counters for all variable depth registers.

Warning: When performing a fill operation with PLANEMODE = 11, this register must contain a non-zero value even though it is not directly used for either the Boundary Mask or the Plane Mask.

Fill operations only function correctly in 4bpp and 8bpp modes. Performing a fill in 16bpp or 32bpp modes may produce undesirable results.

7-0 Read Mask is primarily used when performing bounded fill operations (PIX_CNTL[2]=1). RD_MASK affects the following operations:

- Fill operations using CMD_RECT
- Fill operations using CMD_BITBLT
- Reading data in Across Plane-Mode
- Monochrome to color expansions

RD_MASK is used to allow bit planes to participate in any logical or arithmetic mix:

- 0 = Allow plane to be read
- 1 = Prevent plane from being read

The effect of setting Read Mask = 0 for non-contiguous ranges of bits when an arithmetic mix is selected is undefined. This is because carry bits may propagate to bits (planes) which are masked by Read Mask.

The Read Mask is 8-bits deep in standard (8bpp) modes and in 4bpp modes.

When in 16bpp mode, the Read Mask is 16-bits deep. It is loaded as two consecutive 8-bit I/O writes to the RD_MASK register. There is an internal modulo-2 counter to address the segments of the 16-bit Read Mask register correctly. The extended Read Mask register is mapped P(A), P(B). Any write to EC1, active command, hardware reset or software reset will clear the modulo-

15-8 Reserved (0)

Note: RD_MASK has some special functions during area fill operations. Refer to the discussion of the PLANEMODE bits with respect to area fill described in the Drawing Operations section of this manual.



**COLOR COMPARE REGISTER
(COLOR_CMP)**

Read at I/O Address B2E8h (Chips Extension)
Write at I/O Address B2E8h
Byte or Word Accessible

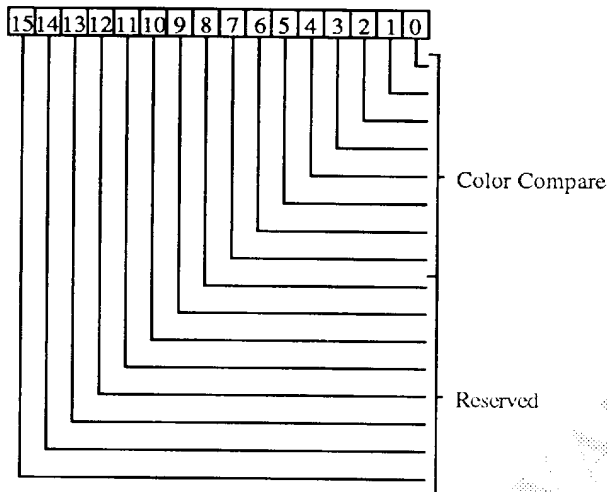

against pixels P(A), P(B) and P(C), P(D). Any write to EC1, active command, hardware reset or software reset will clear the modulo-2 counter.

In 32bpp mode the Color Compare register is 32-bits deep. Four I/O writes are required to write all 32-bits of this register. There is an internal modulo-4 counter to address the segments of the 32-bit Color Compare register correctly. The extended register data is compared against P(A), P(B), P(C), P(D). Any write to EC1, active command, hardware reset or software reset will clear the modulo-4 counter.

There are separate modulo-n counters for all variable depth registers.

Warning: In 16bpp and 32bpp modes, only the "=" COLORCMPOP will function correctly.

15-8 Reserved (0)

7-0 Color Compare defines an 8-bit color which is compared to the destination data during BitBlts. The arithmetic comparison to be used (<, >, =, true, false, etc..) is specified by the COLCMPOP bits of the PIX_CNTL register (MFC[A][5:3]).

If the result of the comparison is true, the destination data is left unchanged. This is like the transparency concept used by Microsoft Windows, but with two differences:

1. The comparison is generalized to include more than just an equality test.
2. The comparison is with the destination data, not the source. IBM refers to this type of comparison as underpaint. PLANEMODE and DRAW can affect the Color Compare.

The Color Compare Register is 8-bits deep in standard (8bpp) modes and in 4bpp modes.

When in 16bpp mode, the Color Compare Register is 16-bits deep. It is loaded as two consecutive 8-bit I/O writes to the COLOR_CMP register. There is an internal modulo-2 counter to address the segments of the 16-bit Color Compare register correctly. The extended register data is compared



BACKGROUND MIX REGISTER (BKGD MIX)

Read at I/O Address B6E8h (Chips Extension)

Write at I/O Address B6E8h

Byte or Word Accessible

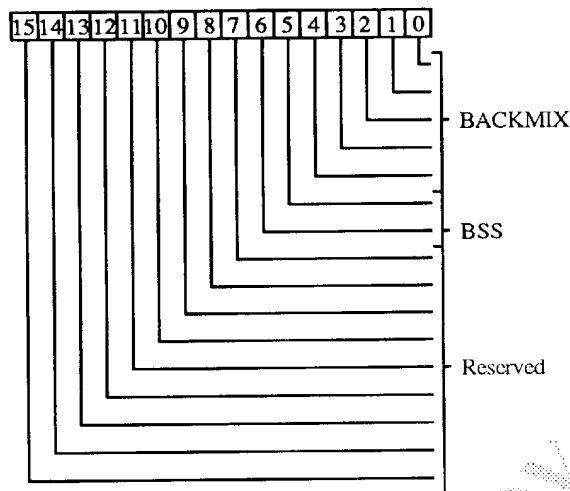

4-0 BACKMIX The background mix defines the mix or raster op to be used in drawing operations. It is analogous to the Foreground Color Mix. One of these two mixes is selected for each pixel in the current nugget based on the PIX_CNTL register. All 16 logical mixes, and five arithmetic mixes (sum, difference, min, max, and average) are supported in 4bpp and 8bpp modes. Only the logical mixes are

supported in the high color 16bpp and 32bpp modes. Options also exist for sum, average, and difference mixes to include saturation (no sum can be greater than 0FFh, and no difference can be less than 0). This prevents visually undesirable effects when these mixes are selected.

6-5 BSS Background Source Select

BSS	Source Selected
0 0	Background Color
0 1	Foreground Color
1 0	Pixel data (PIX_TRANS)
1 1	Bitmap data

Pixel data may be supplied pixel by pixel (through plane mode) or nugget by nugget (across plane mode). This permits data transfer between the screen and system memory. See PIX_TRANS register.

Bitmap data is the source data from the display buffer. The result of doing a line draw or SSV with this source selected is undefined. It is primarily used for BitBlt operations.

15-7 Reserved (0)

Note: In the table below, the destination (DST) operand is always the bitmap destination data, but the source (SRC) operand has four possible sources selected by the BSS bits. There are only 30 unique mixes (24-25, and 28-29 are duplicates).

BACKMIX	Result	BACKMIX	Result
0 0 0 0 0	not DST	1 0 0 0 0	min (SRC, DST)
0 0 0 0 1	0 (false)	1 0 0 0 1	DST-SRC with underflow
0 0 0 1 0	1 (true)	1 0 0 1 0	SRC-DST with underflow
0 0 0 1 1	DST	1 0 0 1 1	SRC+DST with overflow
0 0 1 0 0	not SRC	1 0 1 0 0	max (SRC, DST)
0 0 1 0 1	SRC xor DST	1 0 1 0 1	(DST-SRC)/2 with underflow
0 0 1 1 0	not (SRC xor DST)	1 0 1 1 0	(SRC-DST)/2 with underflow
0 0 1 1 1	SRC	1 0 1 1 1	(SRC+DST)/2 with overflow
0 1 0 0 0	not (SRC and DST)	1 1 0 0 0	DST-SRC with saturate
0 1 0 0 1	(not SRC) or DST	1 1 0 0 1	DST-SRC with saturate
0 1 0 1 0	SRC or (not DST)	1 1 0 1 0	SRC-DST with saturate
0 1 0 1 1	SRC or DST	1 1 0 1 1	SRC+DST with saturate
0 1 1 0 0	SRC and DST	1 1 1 0 0	(DST-SRC)/2 with saturate
0 1 1 0 1	SRC and (not DST)	1 1 1 0 1	(DST-SRC)/2 with saturate
0 1 1 1 0	(not SRC) and DST	1 1 1 1 0	(SRC-DST)/2 with saturate
0 1 1 1 1	not (SRC or DST)	1 1 1 1 1	(SRC+DST)/2 with saturate



T-52-33-45

FOREGROUND MIX REGISTER (FRGD MIX)

Read at I/O Address BAE8h (Chips Extension)
Write at I/O Address BAE8h
Byte or Word Accessible

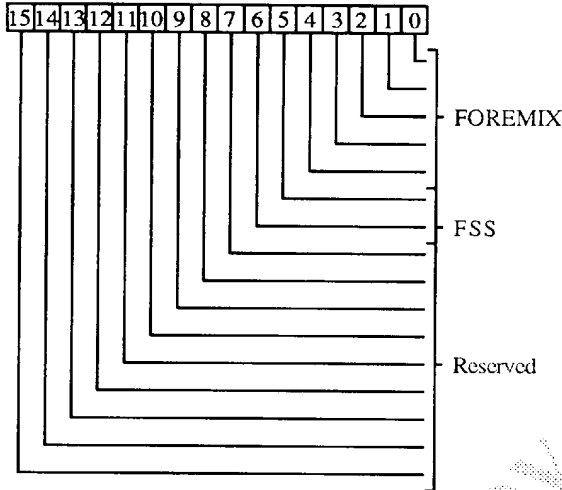

4-0 FOREMIX The foreground mix defines the mix or raster op to be used in drawing operations. It is analogous to the Background Color Mix. One of these two mixes is selected for each pixel in the current nugget based on the PIX_CNTL register. All 16 logical mixes, and five arithmetic mixes (sum, difference, min, max, and average) are supported in 4bpp and 8bpp modes. Only the logical mixes are

supported in the high color 16bpp and 32bpp modes. Options also exist for sum, average, and difference mixes to include saturation (no sum can be greater than 0FFh, and no difference can be less than 0). This prevents visually undesirable effects when these mixes are selected.

6-5 FSS Foreground Source Select

FSS	Source Selected
0 0	Background Color
0 1	Foreground Color
1 0	Pixel data (PIX_TRANS)
1 1	Bitmap data

Pixel data may be supplied pixel by pixel (through plane mode) or nugget by nugget (across plane mode). This permits data transfer between the screen and system memory. See PIX_TRANS register. Bitmap data is the source data from the display buffer. The result of doing a line draw or SSV with this source selected is undefined. It is primarily used for BitBlt operations.

15-7 Reserved (0)

Note: In the table below, the destination (DST) operand is always the bitmap destination data, but the source (SRC) operand has four possible sources selected by the FSS bits. There are only 30 unique mixes (24-25, and 28-29 are duplicates).

FOREMIX	Result	FOREMIX	Result
0 0 0 0 0	not DST	1 0 0 0 0	min (SRC, DST)
0 0 0 0 1	0 (false)	1 0 0 0 1	DST-SRC with underflow
0 0 0 1 0	1 (true)	1 0 0 1 0	SRC-DST with underflow
0 0 0 1 1	DST	1 0 0 1 1	SRC+DST with overflow
0 0 1 0 0	not SRC	1 0 1 0 0	max (SRC, DST)
0 0 1 0 1	SRC xor DST	1 0 1 0 1	(DST-SRC)/2 with underflow
0 0 1 1 0	not (SRC xor DST)	1 0 1 1 0	(SRC-DST)/2 with underflow
0 0 1 1 1	SRC	1 0 1 1 1	(SRC+DST)/2 with overflow
0 1 0 0 0	not (SRC and DST)	1 1 0 0 0	DST-SRC with saturate
0 1 0 0 1	(not SRC) or DST	1 1 0 0 1	DST-SRC with saturate
0 1 0 1 0	SRC or (not DST)	1 1 0 1 0	SRC-DST with saturate
0 1 0 1 1	SRC or DST	1 1 0 1 1	SRC+DST with saturate
0 1 1 0 0	SRC and DST	1 1 1 0 0	(DST-SRC)/2 with saturate
0 1 1 0 1	SRC and (not DST)	1 1 1 0 1	(DST-SRC)/2 with saturate
0 1 1 1 0	(not SRC) and DST	1 1 1 1 0	(SRC-DST)/2 with saturate
0 1 1 1 1	not (SRC or DST)	1 1 1 1 1	(SRC+DST)/2 with saturate



**MULTIFUNCTION CONTROL INDEX REGISTER
(MULTIFUNC_CNTL)**

Read at I/O Address BEE8h (Chips Extension)
Write at I/O Address BEE8h
Byte or Word Accessible

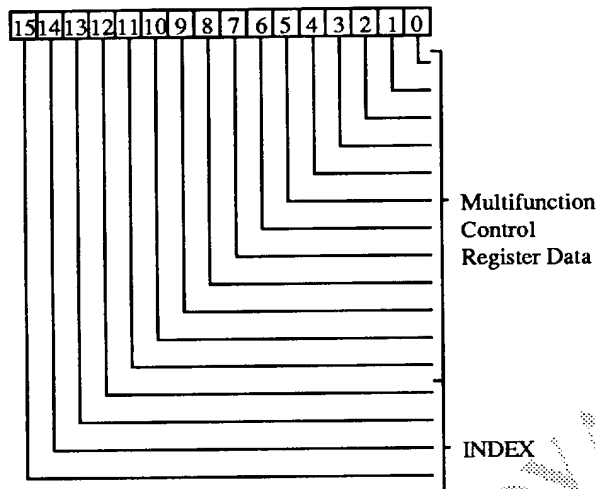

**MINOR AXIS PIXEL COUNT REGISTER
(MIN_AXIS_PCNT)
(MFC[0])**

Read at I/O Address BEE8h (Chips Extension)
Write at I/O Address BEE8h
Byte or Word Accessible

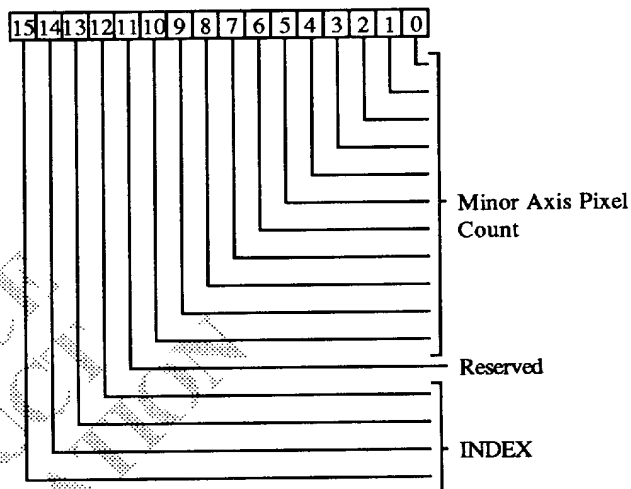

11-0 Multifunction Control Register Data. The MULTIFUNC_CNTL register is the index to a set of registers at the same address. The INDEX bits are used to determine which of the nine currently implemented registers is being written to. This data field is defined for each of the indexed registers in the pages to follow.

The 82C481 also allows these registers to be read. The index of the register to read is written to EC3[3:0] (Multifunction Control Register Read Index), then the register data is read from the least significant 12 bits at this register address (BEE8h); bits 15:12 are undefined.

15-12 INDEX indicates which Multifunction control sub-register is currently being written to.

10-0 Minor Axis Pixel Count is used to define the height for BITBLT and rectangle commands. The actual height is:

$$\text{Minor Axis Pixel Count} + 1$$

11 Reserved (0)

15-12 INDEX = 0000



T-52-33-45

**TOP SCISSORS REGISTER
(SCISSORS_T)
(MFC[1])**

Read at I/O Address BEE8h (Chips Extension)
Write at I/O Address BEE8h
Byte or Word Accessible

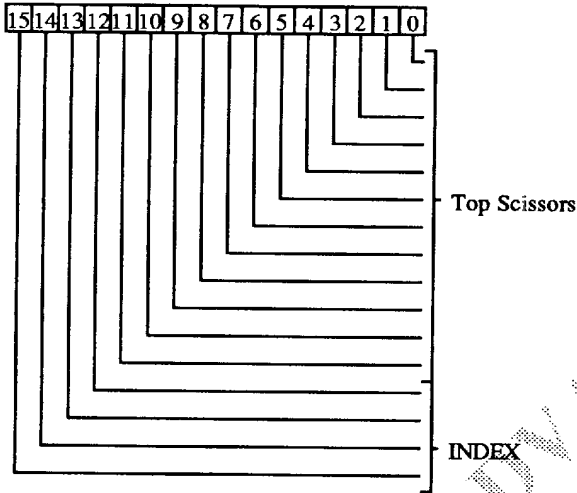

**LEFT SCISSORS REGISTER
(SCISSORS_L)
(MFC[2])**

Read at I/O Address BEE8h (Chips Extension)
Write at I/O Address BEE8h
Byte or Word Accessible

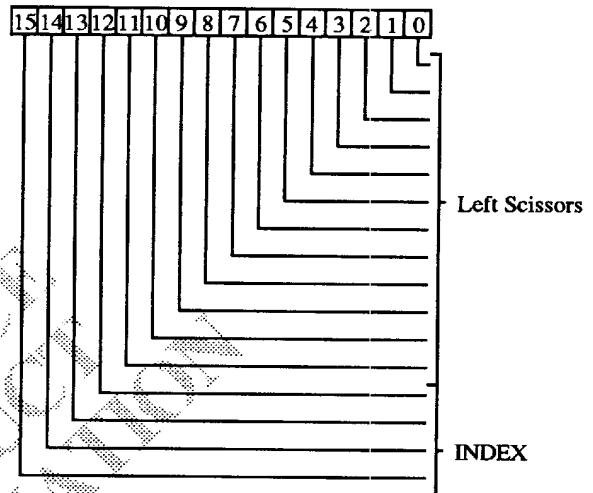

11-0 Top Scissors is the minimum Y coordinate value for the scissors rectangle.

15-12 INDEX = 0001

11-0 Left Scissors is the minimum X coordinate value for the scissors rectangle.

15-12 INDEX = 0010



**BOTTOM SCISSORS REGISTER
(SCISSORS_B)**

(MFC[3])

Read at I/O Address BEE8h (Chips Extension)

Write at I/O Address BEE8h

Byte or Word Accessible

**RIGHT SCISSORS REGISTER
(SCISSORS_R)**

(MFC[4])

Read at I/O Address BEE8h (Chips Extension)

Write at I/O Address BEE8h

Byte or Word Accessible

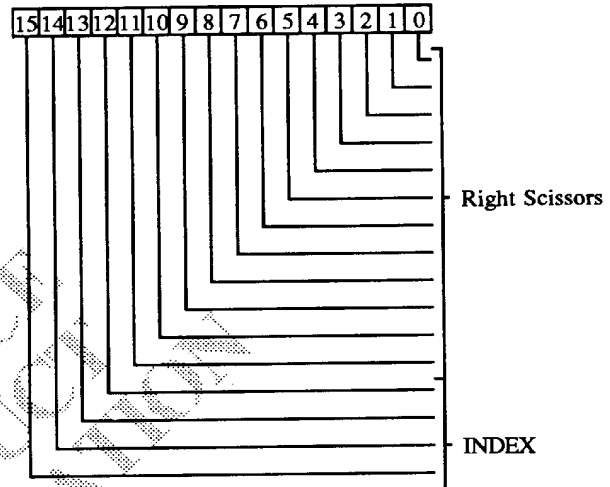
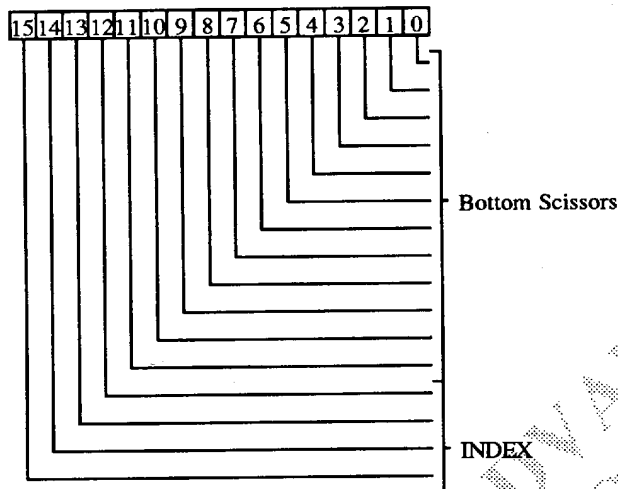

11-0 Bottom Scissors is the maximum Y coordinate value for the scissors rectangle.

15-12 INDEX = 0011

11-0 Right Scissors is the maximum X coordinate value for the scissors rectangle.

15-12 INDEX = 0100

ADVANCE PRODUCT INFORMATION



**MEMORY CONTROL REGISTER
(MEM_CNTL)
(MFC[5])**

Read at I/O Address BEE8h (Chips Extension)
Write at I/O Address BEE8h
Byte or Word Accessible

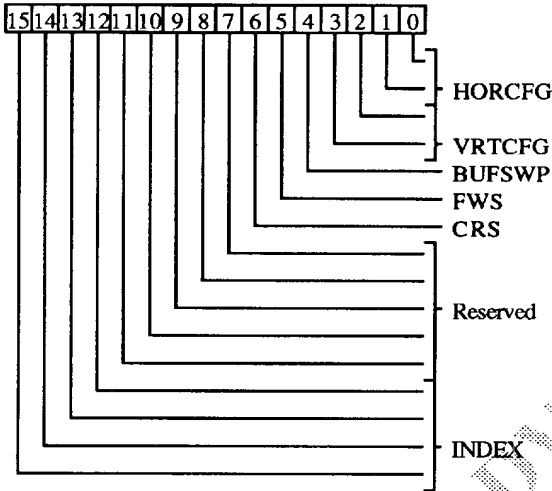

1-0 HORCFG This field contains information which the 82C481 uses to determine the X-Coordinate divisor. Bit 0 is used to indicate 5-pixel operation and should only be set if EC2[11] = 1 (the 5PN bit). Bit 1 determines if the VRAMs are interleaved in the horizontal direction. The interleave table results in the following:

HORCFG	Interleave
00	4
01	5
10	8
11	10

Note: This table is only valid for 256K VRAMs. For a complete table relating Interleave factors for 1M VRAMs, see the Initialization/Configuration chapter of the Functional Description.

HORCFG = 10 always for IBM 8514/A compatible modes. For the 82C481, only the last two values, 10 and 11 are of interest.

3-2 VRTCFG specifies the amount by which to divide the Y coordinate internally when addressing different memory configurations. These bits also determine the bank interleave factor in the Y (vertical) direction. These

bits are re-interpreted when 1Mbit VRAMs are used to maintain software compatibility with the IBM 8514/A (which used 256Kbit VRAMs). These bits are related to the number of VRAM banks in the system. The number of installed banks may be determined by reading EC2[9:8] (BANKS). When 8BP = 0, writing VRTCFG = 00 invokes Pseudo 8-Plane mode (PS8). Writing VRTCFG ≠ 00 deactivates PS8 mode.

VRTCFG	VRAM Banks
0 0	0.5
0 1	1
1 0	2
1 1	4

VRTCFG = 01 is the 8514/A standard value (4 banks either 4-planes or 8-planes deep).

VRTCFG = 1x is used for extended resolutions beyond 1024x768. These bits are always programmed to the same value as the MEM_CFG bits of the DISP_CNTL register. They determine the number of scan lines per row address.

4 BUFSWP is used to select planes when in Pseudo 8-plane (PS8) mode:

- 0 = select buffer 0 (lower 4 planes)
- 1 = select buffer 1 (upper 4 planes)

BUFSWP = 0 when not in PS8 mode.

5 FWS Flash Write Cycle Select. When FWS = 1 and FWE (EC1[5]) = 1, the FWE pin initiates a Flash Write cycle (with Write per Bit masking) on the entire VRAM row (512 bits). This is the fastest way to clear the screen to a specified color. Use a RECT command of width

$$(32/BPP) * (BANKS[0]+1).$$

5 CRS Color Register Set Cycle. When this bit is set and FWE (EC1[5]) = 1, the current drawing operation writes data to the VRAM color register rather than the memory. The VRAM color register stores the value which is used during Flash Write cycles. Use any drawing command which will perform VRAM write cycles to all of the VRAMs in all banks (eg. a RECT command of the same width defined above for Flash Write Cycles).

11-7 Reserved (0)

15-12 INDEX = 0101



**FIXED PATTERN LOW REGISTER
(PATTERN_L)**

(MFC[8])

Read at I/O Address BEE8h (Chips Extension)

Write at I/O Address BEE8h

Byte or Word Accessible

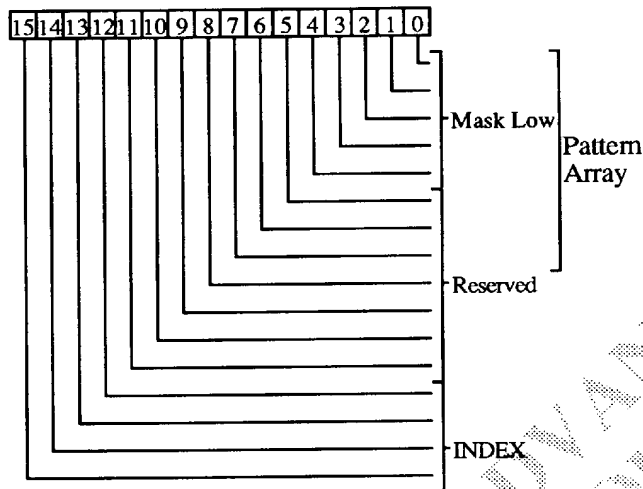

4-0 Mask Low is used to select the mix on a pixel by pixel basis. If MIXSEL = 01, then the pattern registers are used to select foreground or background mix. Mask Low applies to even numbered nuggets (0 is leftmost on the screen); Mask High is applied to odd numbered nuggets.

- 0 = select BACKMIX
- 1 = select FOREMIX

The bits are in left to right order as they would appear on the display:

- 4 = pixel 0 (within a nugget)
- 3 = pixel 1
- 2 = pixel 2
- 1 = pixel 3
- 0 = pixel 4 (if 5PN mode)

7-0 Pattern Array. When PATTERN (EC1[10]) = 1, the 8 x 8 pattern array is loaded by 8 consecutive I/O writes to this location. There is an internal modulo-8 counter which directs data into the 8 x 8 array. The modulo-8 counter is cleared by an I/O write to EC1, an active command, a hardware reset, or a software reset.

The pattern array data is used to select the mix on a pixel by pixel basis. If MIXSEL = 01 and PATTERN = 1, then the pattern

array data is used to select foreground or background mix.

- 0 = select BACKMIX
- 1 = select FOREMIX

The bits are in left to right order as they would appear on the display:

- 7 = pixel 0 (leftmost on the screen)
- 6 = pixel 1
- ...
- 1 = pixel 6
- 0 = pixel 7 (rightmost on the screen)

The pattern data is destination aligned. The pattern data is vertically aligned such that the least significant 3 y-ordinate address bits select the pattern register row. The pixels are horizontally aligned within a double nugget (8 pixels) such that the least significant 3 bits of x-ordinate selects the x pattern bit.

A further explanation of the Pattern Array function is contained in the Drawing Operation section of the Functional Description.

Warning: The Pattern Array only works in 4 pixel nugget operation with VRTCFG = 00 or 01.

- 11-5** Reserved (0)
- 15-12** INDEX = 1000



**FIXED PATTERN HIGH REGISTER
(PATTERN_H)
(MFC[9])**

T-52-33-45

Read at I/O Address BEE8h (Chips Extension)
Write at I/O Address BEE8h
Byte or Word Accessible

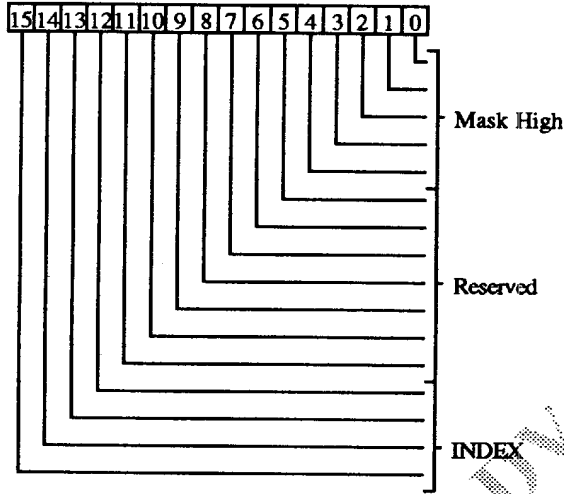

4-0 Mask High is used to select the mix on a pixel by pixel basis. If MIXSEL=01, then the pattern registers are used to select foreground or background mix. Mask High applies to odd numbered nuggets (0 is leftmost on the screen); Mask Low is applied to even numbered nuggets.

- 0 = select BACKMIX
- 1 = select FOREMIX

The bits are in left to right order as they would appear on the display:

- 4 = pixel 0 (within a nugget)
- 3 = pixel 1
- 2 = pixel 2
- 1 = pixel 3
- 0 = pixel 4 (if 5PN mode)

Note: The PATTERN_H register is not used when the pattern array is enabled.

- 11-5 Reserved (0)
- 15-12 INDEX = 1001



T-52-33-45

**PIXEL CONTROL REGISTER
(PIX_CNTL)
(MFC[A])**

Read at I/O Address BEE8h (Chips Extension)
Write at I/O Address BEE8h
Byte or Word Accessible

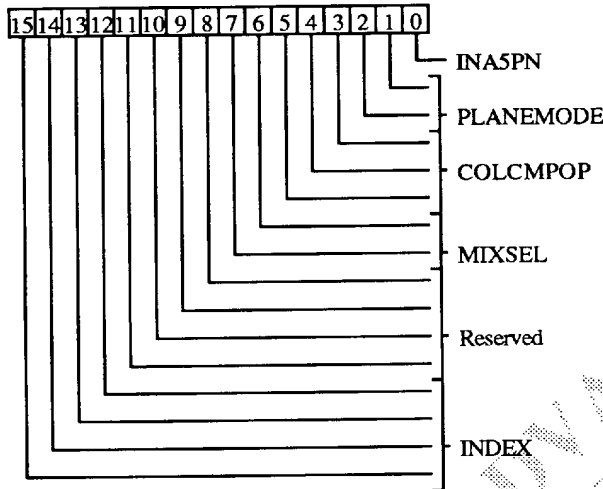

0 INASPN (Intra-Nugget Alignment)
Determines the modulus for alignment of BitBlt data in the internal data buffer.

- 0 = Modulus 4 (4PN)
- 1 = Modulus 5 (5PN)

2-1 PLANEMODE

- 0 0 = Normal Operation
- 0 1 = Indeterminate
- 1 0 = Fill area using RD_MASK as boundary mask. Does not fill second edge of boundary. Plane Mask is a mixture of RD_MASK and WRT_MASK.
- 1 1 = Fill area using WRT_MASK as boundary mask. Does fill second edge of boundary. Plane Mask is WRT_MASK (although RD_MASK must be non-zero for correct operation).

Note: For a complete description of area fill and the interactions of the PLANEMODE bits and masks, refer to the Area Fill discussion in Drawing Operations.

Warning: Area Fill operations only function in 4bpp and 8bpp modes.

5-3 COLCMPOP (Color Comparison Operation)
These bits determine the comparison operation performed on each pixel.

COLCMPOP Operation

0 0 0	False	(always write DST)
0 0 1	True	(never write DST)
0 1 0	DST >=	COLOR_CMP
0 1 1	DST <	COLOR_CMP
1 0 0	DST ≠	COLOR_CMP
1 0 1	DST =	COLOR_CMP
1 1 0	DST <=	COLOR_CMP
1 1 1	DST >	COLOR_CMP

Only False (000) and 'DST = ' (101) function correctly in 16bpp and 32bpp modes.

7-6 MIXSEL (Mix Select)

- 0 0 = FOREMIX is always used
- 0 1 = PATTERN_L,PATTERN_H select mix if PAT (EC1[10])=0. Pattern array selects mix if EC1[10]=1. (1 = FOREMIX, 0 = BACKMIX)
- 1 0 = Variable pixel data (from PIX_TRANS) selects the mix (1 = FOREMIX, 0 = BACKMIX).
- 1 1 = SRC selects the mix (used to implement transparency during a BITBLT command).

11-8 Reserved (0)

15-12 INDEX = 1010

T-52-33-45

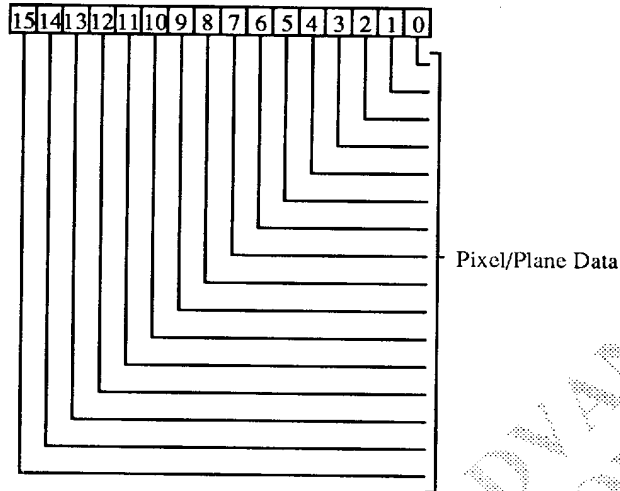
**PIXEL DATA TRANSFER REGISTER
(PIX_TRANS)***Read at I/O Address E2E8h**Write at I/O Address E2E8h**Byte Accessible (16BIT=0)**Byte or Word Accessible (16BIT=1)*

- 15-0** Pixel/Plane Data In through planes mode (PLANAR=0), bits 7:0 and 15:8 map onto bit planes 7:0 of an individual 8-bit pixel (PnD7:0). In across planes mode (PLANAR=1), bits 4:0 and 12:8 map onto pixels 0:4 within a 4/5 pixel group (1 bit per pixel).

The PIX_TRANS register can be used to allow data reads or writes to the display buffer. It can also be used to apply any arbitrary pattern during BITBLT or LINE drawing operations (4bpp or 8bpp mode only).

For high color modes, the only support for pixel data is through the CMD_RECT command (X-direction rectangle). Through Plane operation functions at all pixel depths. Across plane mode writes also function as expected. Across Plane reads only function in 4bpp and 8bpp modes.

The high color modes (16bpp and 32bpp) also have the restriction that they can only function with 16BIT=1 (ie. 16 bit accesses to the PIX_TRANS register). The pixel data order is similar to the 8bpp order in both modes. The byte order of the PIX_TRANS high/low bytes is still controlled by BYTSEQ. In 32bpp mode the first two

bytes go to P1D7:0 and POD7:0. The second two bytes go to P2D7:0 and P3D7:0. In 16bpp mode the PIX_TRANS data goes to one of the two byte pairs.

In across plane mode the 8 active bits (12:9, 4:1) still control 8 pixels. (The number of bytes drawn and thus the number of memory cycles required is 2 or 4 times as many).

WARNING: PIX_TRANS data functions only in CMD_RECT if M16=1 or M32=1.

WARNING: The type of data transfer operation performed depends upon the state of the 16BIT bit in the CMD register. The IBM 8514/A actually only functions correctly when 16 bit I/O transfers are performed. The useful data transferred however does depend on 16BIT. That is, if 16BIT=0, then an IN AX,DX reads 8 bits of valid data on the low data bus (AL) and no valid data on the high data bus (AH). Although an IN AL,DX to E2E8h will read the correct data, it does not clear the DATARDY bit and the graphics processor will remain idle until an IN is performed to E2E9h.

The high byte of PIX_TRANS must always be read/written in order for the command to continue execution. This means that if a byte write is performed to E2E8h, it must be followed by a byte write to E2E9h before the drawing engine will start. This is independent of the state of the 16BIT bit. The effect that the 16BIT bit has is that when 16BIT=1, both high and low bytes written are used (in the order specified by BYTSEQ). If 16BIT=0 however, only the low byte is executed (regardless of the state of BYTSEQ and the data written to E2E9h is ignored). The same is true of the read operation. This means that if a byte read is performed from E2E8h, it must be followed by a byte read from E2E9h before the drawing engine will start again. This is independent of the state of the 16BIT bit. The effect that the 16BIT bit has is that when 16BIT=1, both high and low bytes read are valid data (if BYTSEQ = 1 the high and low bytes are swapped). If 16BIT=0 however,



only the low byte is valid data (the data read from E2E9h should be discarded).

This is how the IBM 8514/A functions and is duplicated in the 82C481 for compatibility. The IBM Adapter Interface (AI) always appears to communicate with the 8514/A using 16-bit I/O instructions so the high byte dummy instructions are never needed. If you intend to write code which will work universally, it is probably safest to follow IBM's lead and always set 16BIT=1. If an odd number of pixels need to be written to PIX_TRANS then the high byte of the last output is discarded. Likewise, when inputting an odd length from the PIX_TRANS register, the high byte of the final data transfer may be discarded.

Note: For compatibility, this register may also be read at A2E8h and A6E8h during drawing commands.

PIXEL DATA TRANSFER REGISTER (PIX_TRANS)

*Read at Memory Address Range 0A0000-0BFFFFh
Write at Memory Address Range 0A0000-0BFFFFh
Word Accessible Only (16BIT=1)*

The PIX_TRANS register may also be memory mapped in the UISA bus interface mode. This is useful for accelerating system memory to screen memory transfers on the ISA bus. Standard 16-bit I/O transfers require 3 bus cycles whereas 16-bit memory transfers may be completed in 2 bus cycles by exerting a 0WS- signal. (For example a 10MHz ISA bus would be capable of transferring 10MBytes/sec across the memory bus compared to only 6.66MBytes/sec across the I/O bus).

The PIX-TRANS register may be mapped into one or more of three memory ranges selected by PTR (EC0[2:0]). These ranges map into the display adapter reserved memory range (VGA / EGA / CGA / MDA) which is usually under the control of the display driver controlling the 82C481. If there is a VGA in the system operating in text mode then this leaves the range 0A0000h-0AFFFFFh unused and available for memory mapping the PIX_TRANS register.

The reason that a range is used and not a single location is so that the software developer may use a REP MOVSW instruction to perform system to screen or screen to system BITBLTs. Data written to the memory is redirected into the queue as if it were an I/O write to the PIX_TRANS register. Queue overflow and time-out functions are handled in the same manner as for I/O cycles.

PIX_TRANS memory mapping can only be used in UISA mode. The VMR bits corresponding to the PTR bits must be set to request 16-bit data transfers on the ISA bus. To run the minimum 2 bus cycle memory data transfers, ZWS must be enabled.

When the PIX_TRANS register is memory mapped it does not effect its I/O mapping. Accesses to either location will result in data flowing to/from the PIX_TRANS register.



System Interface

The 82C481 can interface as a slave to 2 different system buses: MC (Micro Channel) and ISA (Industry Standard Architecture or PC/AT). It can interface to the ISA bus in 2 different ways (ISA and UISA). The 82C481 auto-configures to 8-bit or 16-bit slots on either bus. MC mode is the default, ISA mode is selected by tying ISA/ low, UISA mode is selected by pulling CSEL2 low during reset.

In either mode, the 82C481 supports I/O reads, I/O writes, memory reads, and interrupts. It supports memory writes in UISA mode only. It does not support, burst mode transfers, matched-memory transfers, 32-bit transfers, or any Bus Master functions. All reads or writes are of the 'Asynchronous-Extended' variety where an I/O Channel Ready signal from the chip controls the length of the cycle. On I/O accesses to the queue when the queue is not full, the bus default cycle is executed (Channel Ready not exerted). In UISA mode system memory to/from screen memory transfers may be completed in a shortened 16-bit memory cycle by exerting -0WS.

82C481 registers are mapped into areas which skip around in I/O space (see the IO Map, at the beginning of the register section). However, since PC/AT system boards decode only the lower 10 address bits as 'official' I/O addresses, all internal registers appear initially at PC/AT I/O address 2E8h. The rest of the address bits appear on the ISA bus, and are necessary for proper register selection, but are "don't cares" for some motherboard peripherals. Using the IBM standard 8514/A I/O mapping minimizes the impact on the PC or AT for potential conflicts. If there are conflicts (such as with a network controller) the base address (2E8h) may be remapped to a non-offending address. This is accomplished by modifying the IOB field in Extended Configuration Register EC0[15:10].

The initialization ROM is memory-mapped, defaulting to the range C8000h-C9FFFh for ISA/UISA buses or C6000h-C7FFFh for MC bus configurations. The display buffer is not memory mapped. The only way to read or write display memory is through the use of 82C481 commands. Control registers for such commands are mapped into I/O space. The data is also accessed through I/O space except in UISA mode where the variable data register optionally memory mapped.

VGA support is provided by the Micro Channel Video Bus Extension (MC systems), or the VESA

video pass-through connector (ISA systems). In VGA mode, video data and video clock are multiplexed to the palette/DAC, and syncs are multiplexed to the video connector. In VGA mode, the 82C481 responds to all writes to the VGA palette (3C6h-3C9h); this ensures the palette displays the VGA colors correctly. By default, the 82C481 does not respond to reads of the VGA palette to prevent bus contention. If it is required that the 82C481 respond to I/O read accesses, this may be enabled by setting PRE (EC1[15]). This bit is cleared on RESET. This may be desirable in merged 82C481 + VGA designs using a Brooktree Bt484 or equivalent RAMDAC.

Operation of the upper 8 data bits on the MC or ISA bus is controlled by Byte High Enable (BHE/). When the 82C481 is installed on an 8-bit bus, BHE/ is not driven (it is located on the 16-bit connector extension); an internal pull-up holds BHE/ inactive in this case. The 82C481 will not activate Data Size₁₆ (DS16/) for word or odd byte transfers if BHE/ = 1. The host will convert word transfers to byte transfers in this case. Internal byte steering logic directs odd-byte data over D7:0 when BHE/ = 1.

The 82C481 may be used without external data transceivers in motherboard applications where 4 mA drive is sufficient, or with transceivers where 24 mA drive is required. It provides RDLO/ and RDHI/ outputs to control the direction of these transceivers.

Bus signals are connected as follows.

82C481 Pin	MC	ISA	UISA
A23:20	A23:20	Ground	LA23:20
A19:17	A19:17	SA19:17	LA19:17
A16:0	A16:0	SA16:0	SA16:0
BHE/	-SBHE	-SBHE	-SBHE
AEN	M/IO	AEN	AEN
IORD/	-S1	-IOR	-IOR
IOWR/	-S0	-IOW	-IOW
MEMR/	-CMD	-SMEMR	-MEMR
MEMW/	MADE 24	-	-MEMW
IOCS16/	-CD DS16	-IOCS16	-IOCS16
RDY	CD CHRDY	IOCHRDY	IOCHRDY
RFSH/	-RFSH	-RFSH	-RFSH
IRQ	-IRQ9	IRQ9	-0WS / IRQ9
RESET	CHRESET	RESETDRV	RESETDRV
ISA/	-CD SETUP	Ground	BALE
MEMCS16/	-CD SFDBK	-MEMCS16	-MEMCS16



MICRO CHANNEL INTERFACE

Micro Channel mode is selected by default (ISA/ pin and CSEL2 pin not grounded). The following Micro Channel signals are not used: ADL/, PREEMPT/, DS16RTN, CHRDRYRTN, BURST/, TC/, ARBn, ARB/-GNT (all Bus Master/DMA functions), CHCK/, AUDIO, AUDIO GND, and all 32-bit extended signals. Addresses are latched on the falling edge of CMD/.

POS operations are described later in this document.

INDUSTRY STANDARD ARCHITECTURE (ISA) Interface

ISA Mode is selected by tying the ISA/ pin low. The 82C481 doesn't decode LA23:17, so SMEMR/ is used instead of MEMR/. SMEMR/ is used only for the ROM chip select. The 82C481 doesn't generate MEMCS16/ in ISA mode, so it does not support 16-bit ROM; this is not a serious limitation, because those wanting higher performance can copy the ROM to shadow RAM, which offers higher performance than 16-bit ROM.

The following ISA signals are not used: ALE, LA23:17, CLK, NMI/, DRQn, DACKn, T/C, MASTER/, MEMCS16/, OWS/. Only SA addresses are used on chip; these do not need to be latched so ALE is unnecessary.

INDUSTRY STANDARD ARCHITECTURE - UNLATCHED OPTION (UISA) Interface

UISA Mode is selected by tying the CSEL2 pin low. This mode is a superset of the ISA mode which uses unlatched addresses and memory maps the PIX_TRANS variable data register. LA23:17, SA16:15, MEMR/ and MEMW/ are used to decode ROM and PIX_TRANS accesses. The 82C481 also responds with -OWS to terminate memory cycles to the PIX_TRANS register. This interface offers higher performance for system to screen transfers than does the standard ISA interface. Hardware interrupts are sacrificed if -OWS is supported.

The following ISA signals are not used: SA19:17, CLK, NMI/, DRQn, DACKn, T/C, MASTER/. Both LA and SA addresses are used on chip so ALE is necessary.

EXTENDED INDUSTRY STANDARD ARCHITECTURE (EISA) Interface

EISA is a superset of the ISA bus. To interface the 82C481 to an EISA bus, use the signal connections as described for the ISA or UISA bus. No EISA extensions to the ISA architecture are supported.

POS Operations are not supported in ISA/EISA mode.

QUEUE

To improve performance, the 82C481 provides a write queue (called the "queue") for all registers at I/O address 8000h or greater. This includes all graphics processor registers. The only registers whose write data is not queued are CRT controller, palette, interrupt, and extended configuration registers. The queue improves efficiency of writing drawing commands and parameters, as well as for Variable Data---data provided to/from the host via the PIX_TRANS register (I/O mapped or memory mapped) while executing a drawing command. This is the mechanism whereby data is copied between the bitmap and system memory. Thousands of pixels may be transferred during a single 82C481 command, so a queue is imperative.

Because drawing parameters are queued, changes to these registers (such as changing the drawing color) will not take effect until any drawing operations in progress are finished. This allows parameters to be set for the next command immediately.

The queue is 16 words by 20 bits (16 data, 4 address). A23:15 and A9:0 are decoded to select the queue for writing; A13:10 go into the queue along with the 16 data bits, and are decoded upon leaving the queue to select the destination register.

The GP_STAT register at 9AE8h is used to poll the status of the read and write queues:

- Bit-9 GPBUSY (1=Busy)
- Bit-8 DATARDY (1=Pixel Transfer Data Ready)
- Bit-7:0 00000000 = 16 words available
- 00000001 = 7-15 words available
- 00000011 = 6 words available
- 00000111 = 5 words available
- 00001111 = 4 words available
- 00011111 = 3 words available
- 00111111 = 2 words available
- 01111111 = 1 words available
- 11111111 = 0 words available (queue full)

Bits 7:0 of this register is the Queue State (QS) field which shows the number of words available in the queue. Nicknamed the "thermometer" register, it shows the number of bytes available, encoded linearly. QS tells not only that there are words available, but how many; this can reduce the amount of polling necessary. QS = 0 does not imply the 82C481 graphics processor is idle; it may still have data waiting in its hidden lower 8 words, or it may have consumed all the data from the queue but still be executing a drawing command. Always test the



T-52-33-45

GPBUSY bit to determine if the graphics processor is idle.

The "read queue" is only one word deep, and is used only for Pixel Transfer Data. The Pixel Transfer Data Ready bit (DATARDY) indicates there is data waiting to be read from the PIX_TRANS register (E2E8h).

If a write access to the queue occurs when the queue is full, or a read access to the PIX_TRANS register occurs when there is no data available then the 82C481 extends the I/O (or memory) cycle automatically. If after a timeout interval, space does not become available in the queue, or for a read no data becomes available, then the 82C481 terminates the bus cycle. After terminating an unsuccessful bus cycle, the 82C481 internally generates an INVALIDIDIO interrupt. If this interrupt is enabled it will generate an external interrupt. In any event, it will set internally and no further drawing engine operation will occur until it is cleared.

INTERRUPTS

The interrupt request (IRQ) pin supports interrupts on the MC or ISA bus. IRQ is normally attached to IRQ9 on either the MC or ISA bus. In MC mode, IRQ acts as an active-low open-collector output. In ISA mode, IRQ is 3-stated when no interrupts are enabled, it is driven low when interrupts are enabled but not active, and is driven high when interrupts are enabled and active (this is like the EGA/VGA). IRQ9 may be shared with another adapter on the ISA bus if only one has its interrupts enabled at a time. In either case, IRQ has no internal pull-up or pull-down; it relies on the motherboard to pull IRQ to an inactive state.

IRQ has IOL min = -12 mA. While this does not technically meet the ISA or MC 24 mA spec, the board designer may still want to drive IRQ9 directly, instead of using an external 74LS125 driver.

There are four internal sources of interrupts:

IRQ3 Idle (GPIDLE): The 82C481 graphics processor is idle and the queue is empty. The GPIDLE interrupt may be used as a substitute for polling of the GPBUSY bit prior to writing a drawing command and parameters. Once the 82C481 is idle, the next command and parameters may be written to the queue at 8000h-FFFFh without polling the Queue State bits.

IRQ2 Queue over/underflow (INVALIDIDIO): An attempt has been made to write to the queue when no words were available, or to read PIX_TRANS when no data was ready. This

interrupt is generated only after the bus cycle has been extended and a timeout occurs on the cycle.

IRQ1 Write inside scissor rectangle (PICKFLAG): The 82C481 has written the display buffer within the Scissor Rectangle while executing a CMD_LINE, CMD_LINEAF, CMD_RECT, CMD_RECTV1, CMD_RECTV2, the destination phase of a CMD_BITBLT command or a SSV. IRQ1 is used for picking operations. This interrupt only functions in 4bpp and 8bpp modes.

IRQ0 Vertical Blank (VBLNKFLAG): Vertical blanking is active. IRQ0 may be used to synchronize operations (such as scrolling) to the end of the frame.

Each internal interrupt goes active whenever the specified condition is true. The state of the internal interrupts may be read from the corresponding interrupt field in the Subsystem Status Register. However, the IRQ pin will only be activated when the condition becomes active, and only if that particular internal interrupt was already enabled by the corresponding interrupt enable bit in the Subsystem Control Register. To inactivate IRQ, each active internal interrupt must be cleared by writing 1 to the corresponding interrupt reset bit in the Subsystem Control Register. Interrupts may be cleared individually or in combination.



ADVANCE
PRODUCT
INFORMATION

Memory Interface

T-52-33-45

MEMORY ARCHITECTURE

The 82C481 is designed to use 256K or 1M VRAMs only (not DRAMs). Write-Per-Bit and Enhanced Page Mode features are required. The 82C481 uses a 40-bit VRAM data bus. This bus is called the Pixel Bus, and the pins are labeled PxDy where x = 0-4 and indicates the (8-bit) pixel position within a nugget (see next section) and y = 0-7 indicates the bit (plane). Each pixel has its own write enable pin (WE4:0), and each plane is selectively written using the VRAM Write-Per-Bit mask.

The 82C481 uses a packed pixel architecture. Each 8-bit pixel is stored in a pair of VRAMs; one holds the lower nibble, one the upper nibble. 512K 4-bpp (bit-per-pixel) systems are implemented by simply not populating the upper nibble VRAM locations. Because the VRAMs are four bits wide, the smallest number of bits per pixel for the display buffer is 4. However, by using the Plane Read Mask (RD_MASK), Plane Write Mask (WRT_MASK), and Palette Mask (DAC_MASK) registers, you can effectively divide the 4-bpp display buffer into two 2-bpp buffers or four 1-bpp buffers, each with the same resolution as the original 4-bpp buffer. This does not reduce VRAM requirements or increase resolution compared to 4-bpp, but does allow implementing a double-buffered 2-bpp or quadruple-buffered 1-bpp system using the same display buffer as for a 4-bpp system.

The 82C481 has a separate Memory Clock (MCLK) which may be adjusted to match the speed of the VRAMs used. Maximum frequencies are 40 MHz (for 100 ns VRAMs), 32 MHz (120 ns VRAMs), or 25 MHz (150 ns VRAMs). MCLK is asynchronous to Nugget Clock (NCLK), which controls video timing.

Nuggets

At this point, some terms must be defined: a nugget is the fundamental "word" of the 82C481. A nugget is either 32 or 40 bits, depending on the 5 Pixel Nugget (SPN) bit. A double nugget is two nuggets (64 or 80 bits), from the same row and column address of a horizontally interleaved pair of RAM banks. Double nuggets are the basic unit of all 82C481 horizontal video parameters.

Within a nugget, the pixels are "backwards" order. Pixel 0 (the rightmost pixel when the nugget is viewed as a 40 bit word) appears in the leftmost

position on the screen. In 8bpp and 4bpp modes pixels 1, 2, 3, and 4 appear in left-to-right order on the screen. In 16bpp mode pixels 1+2, and 3+4 are concatenated to form 2 pixels per nugget. In 32bpp mode pixels 1, 2, 3, and 4 are concatenated to form a single pixel per nugget. In Across-Planes mode, Pixel Transfer Data (PIX_TRANS) bits appear in the "correct" order. Only the least significant 5 bits of PIX_TRANS are used; bit-4 controls pixel-0 (the leftmost pixel as it appears on the screen), bits 3, 2, 1, and 0 respectively control pixels 1, 2, 3, and 4. Bit 0 is used only if in 5-pixel nugget modes.

The two halves of a double nugget are referred to as A and B, where A appears to the left of B on the screen.

The 82C481 may use one, two, or four RAM banks. The 82C481 VRAM banks are named Bank 0, 1, 2, and 3; if a single bank is used it is Bank 0; if two banks are used they are Banks 0 and 1. The 82C481 interleaves between banks using just a single pixel data bus. If a single bank is used, of course no interleaving is possible. If two banks are used, Banks 0 and 1 are interleaved horizontally ("horizontally" refers to the location of words from the same row and column address as they appear on the screen). If four banks are used, Banks 0 and 1, and Banks 2 and 3 are interleaved horizontally. Banks 0 and 2 or 1 and 3 are interleaved vertically. Banks 1 and 2 or 0 and 3 may interleave cycles when moving diagonally during line drawing operations.

Variable size nuggets (32/40) allow efficient support of 1280 horizontal resolution. When configured for 1024 horizontal resolution (32-bit nuggets) using eight 1 Mb VRAMs, the longest scan line which can be shifted out of the standard VRAM shift registers is:

$$\frac{(512 * 4)\text{bits/RAM} * 8 \text{ VRAMs}}{8 \text{ bits/pixel} * 2 \text{ scan lines/row address}} = 1024$$

By adding two more 1Mb VRAMs (40-bits, or 5 pixels, per nugget), the maximum horizontal resolution is increased to 1280:

$$\frac{(512 * 4)\text{bits/RAM} * 10 \text{ VRAMs}}{8 \text{ bits/pixel} * 2 \text{ scan lines/row address}} = 1280$$



T-52-33-45

Variable size nuggets have the following advantages:

1. Each VRAM row has exactly 2048 or 2560 (twice 1024 or 1280) pixels; there are no VRAM words wasted.
2. Each scan line is aligned to VRAM row boundaries and is totally contained in the VRAM row. There is no need for split buffer VRAMs nor data transfer cycles "on the fly".

1Mb VRAM Support

The 82C481 allows a 1024 x 768 system to be implemented with just four 1Mb VRAMs (for 16 colors) or eight (for 256 colors). Supporting 1M VRAMs reduces overall graphics system chip count and board area requirements. Also, a 1MByte frame buffer can support a 1280 x 1024 x 4bpp display.

Pseudo 8-Plane Mode

When the 8514/A board is configured for minimum memory (512KB) it normally supports four planes at 640 x 480 or 1024 x 768 resolution. Pseudo 8-plane mode (abbreviated PS8 mode) supports eight planes at 640 x 480 resolution, even though only four planes of the display buffer are populated. In this mode, data is stored as two separate 4-bpp buffers at different addresses, but is displayed together with Buffer 0 appearing as the low nibble and Buffer 1 appearing as the high nibble. During drawing operations, the high and low nibble (i.e. Buffer 1 and 0) are written separately, and the color indices and plane masks are left shifted by four bits when drawing the upper nibble. This mode is entered by setting the Y_Coordinate Divisor (VRTCFG) to 00, and the buffers are selected by setting the Swap bit; BUFSWP = 1 for Buffer 1 or BUFSWP = 0 for Buffer 0. BUFSWP = 0 always when not in Pseudo 8-Plane mode. You can only enter pseudo eight plane mode if 8BP=0 and BANKS=00 (ie. the 82C481 is configured as a 512K subsystem).

The IBM 8514/A requires programming of VRTCFG = 01 (normal) or 00 (pseudo 8-plane mode). The 82C481 interprets the VRTCFG registers to enable Pseudo 8-Plane mode for software compatibility, but it doesn't use VRTCFG to determine the number of VRAM banks. It does use VRTCFG to determine the y-ordinate addressing for the drawing engine.

The 82C481 finds the number of VRAM banks installed by reading strapping options on the CAS3:2/ pins, which are latched into Extended Configuration register EC2[9:8]. Pseudo 8-plane mode is only allowed in medium resolution (640 x 480). The Pseudo 8-plane logic is incorporated in the 82B484 Video Support Chip.

MEMORY CONFIGURATIONS

The 82C481 supports 12 possible memory configurations, which may be categorized by the number of planes (4 or 8), number of banks (1, 2 or 4), and the nugget width (4 or 5 pixels). To simplify things, the configurations are numbered, with up to four characters as follows:

- 1, 2, or 4: the number of banks
- M: to indicate 1 Mb VRAMs are used
- W: if 5 pixel nuggets (wide nuggets)
- D: if 8 planes are used (deep memory)

High color modes are a display subset of 8-plane configurations (hence they have the same memory configuration values). The following figure summarizes the configurations:

* 8514/A register-compatible configurations

Note: Maximum resolutions assume a 4:3 aspect ratio (except

# of VRAM Banks	Nugget Width (pixels)	# of Planes	Memory Configuration	# of VRAM Chips	Bitmap size (KB)	Maximum Resolution
1	4	4*	1M	4	512	1024x768x4
		8*	1MD	8	1024	1024x768x8
		16	1MD	8	1024	640x480x16
	5	4	1MW	5	640	1280x1024x4
		8	1MWD	10	1280	1280x1024x8
		16	1MWD	10	1280	1280x1024x4
2	4	4	2M	8	1024	1280x1024x4
		8	2MD	16	2048	1280x1024x8
		16	2MD	16	2048	1024x768x16
	5	32	2MD	16	2048	640x480x32
		4	2MW	10	1280	1280x1024x4
		8	2MWD	20	2560	1280x1024x8
4	4	4	4M	16	2048	2048x1536x4
		8	4MD	32	4096	2048x1536x8
		16	4MD	32	4096	1280x1024x16
	5	32	4MD	32	4096	1024x768x32
		4	4MW	20	2560	2560x2048x4
		8	4MWD	40	5120	2560x2048x8

1280 x 1024 which is not 4:3 but is in common use). Maximum horizontal resolution is determined as shown on the previous page, by the combined length of the VRAMs serial buffers.

Memory configurations are selected by strapping options on CAS3:2/ (BANKS), WE4/ (5PN), MA8 (1MVRAM), and P4D7 (8PLANE) pins. All options may be connected to jumpers, or overwritten by software to allow user upgrades (see Initialization section). The most common user upgrade would be from a 4-plane to an 8-plane configuration (e.g. 1M to 1MD); another upgrade might be from a 1024 x 768 x 8bpp adapter to a 1280 x 1024 x 8bpp one (e.g. 1MD to 2MD). The wide (5PN) memory configurations are less common than the 4PN configurations because of the more complicated software interface.



T-52-33-45

Configurations other than **1M**, or **1MD** are referred to as Extended Configurations. Extended Configurations require custom drivers, although some 8514/A drivers will be compatible with some Extended Configurations.

Whenever possible, the 82C481 interleaves VRAM banks to improve performance. VRAMs are designed so that pixels on the same scan line (i.e. same Y-coordinate) map to the same row address; bank interleaving is very effective in the X-direction because interleaved page-mode cycles can be used across a whole scan line (unless interrupted for RAM refresh). Only 1 to 4 scan lines fall in the same row address, so page mode can only be used for one to four consecutive pixels in the Y direction. This makes interleaving much less effective in the Y direction. Bank interleaving is impossible in Memory Configuration **1M** and its variations, which use only one bank.

In two-bank configurations, Bank-0 and Bank-1 are interleaved in the X direction on a nugget basis—32/40 bits in Bank 0, 32/40 bits in Bank 1, 32/40 bits in Bank 0, ...

In four bank configurations, banks are interleaved in both the X and Y direction. Banks interleave 0/1 or 2/3 in the X direction; Banks interleave 0/2 or 1/3 in the Y direction. Banks interleave 0/3 or 1/2 when movement is on a diagonal, such as for Short Stroke Vectors (SSVs).

Memory Configurations **1M** and **1MD** are register compatible to the IBM 8514/A in minimum and maximum memory configurations, respectively, but use 4 or 8 1Mb VRAMs instead of 16 or 32 256Kb VRAMs. A 1280 x 1024 x 4bpp resolution is also possible from **1MD** although this is not IBM 8514/A compatible.

Memory Configurations **1MW** and **1MWD** are extended configurations which support resolutions up to 1280 x 1024. This is also the maximum resolution available in a **2MW** or **2MWD** memory configuration. Because a 1280 x 1024 resolution implemented in 1 bank would consume all of the video memory for the display, it may be preferred to use the 2 bank implementation. This would leave some off-screen memory which could be used by an accelerated GUI driver.

Memory Configurations **4M** and **4MD** are extended configurations which support resolutions up to 2048 x 1536 x 8bpp and 1024 x 768 x 32bpp.

Memory Configurations **4MW** and **4MWD** are extended configurations which support resolutions up to 2560 x 2048. This is the highest resolution configuration.

RAM CYCLE TYPES

The 82C481 performs the following types of VRAM cycles:

1. Read (page mode)
2. Write (page mode)
3. Read-modify-write (page mode)
4. RAS-only refresh
5. Data Transfer
6. Color Register Set
7. Flash Write

Read, write, RMW, color register set, and flash write cycles may be bank interleaved. RAS-only refresh and Data Transfer cycles are performed on all banks simultaneously.

All read, write, flash write, or RMW cycles start by writing the VRAM Write-Per-Bit register, used to implement bit plane masking. The mask data comes from the Plane Write Mask register (WRT_MASK). The VRAM Write-per-Bit registers are written by holding WE3:0/ all active at the falling edge of RAS/, while driving the WRT_MASK data on the pixel data bus. Note that the WRT_MASK is always as wide as the pixel depth.

There are three sources of VRAM cycle requests:

1. Drawing engine (read, write, and RMW)
2. CRT Controller (Data Transfer)
3. RAM refresh logic (RAS-only refresh)

Data Transfer cycles have highest priority. All CAS/ lines go low simultaneously only during a Data Transfer cycle.

RAM refresh cycles have the next highest priority.

Drawing engine cycles have the lowest priority. All of these cycles except the color register set start by writing the VRAM write-per-bit register. Drawing engine operations will be done in a single page-mode cycle, unless one of the following happens:

1. RAM row address boundary is crossed by drawing engine; indicated internally by:
 - a. Y Row Address changing.
 - b. Y Coordinate register (CUR_Y) reloaded by host.
 - c. Y Coordinate register (CUR_Y) reloaded internally.
 - d. Changing from source to destination phase of Copy Rectangle (CMD_BITBLT) command. This may happen many times for a large rectangle. Once each time the internal scratch register is filled.



2. The WRT_MASK register is written by the host (requiring new write-per-bit values to be written to the VRAM).
3. A Data Transfer and/or RAM refresh cycle interrupts the page-mode operation.

ADVANCE
PRODUCT
INFORMATION



Video Interface

T-52-33-45

The Video circuitry controls addressing and timing for the VRAM display and memory refresh functions. It handles high or low resolutions in interlaced or non-interlaced display modes with equal ease, and generates programmable sync polarities for controlling different monitor modes.

The hardware is based around 2 principal counters, the Horizontal Counter (HCNT) and the Vertical Counter (VCNT). The values in the Video Registers are compared with these counters to generate Blanking and Sync signals, as well as VRAM Refresh and Data Transfer cycle requests. Two other counters determine Horizontal and Vertical Sync Pulse Widths. There are no interdependencies on Blank and Sync start times.

The Display Control (DISP_CNTL) register controls whether the Video Circuitry is enabled or reset, and whether interlacing is enabled. It also controls certain memory configuration parameters for display.

HORIZONTAL TIMING

All horizontal timings and register values are in terms of the octet clock (OCLK). OCLK is an internal clock derived from NCLK equalling 8/10 pixel clocks. NCLK must be prescaled using the nugget divisor bits of EC1[13:11] to create an 8/10 pixel OCLK. The Horizontal Counter indicates the octet currently being displayed. 0 corresponds to the leftmost actively displayed octet on the screen. The Horizontal Total (H_TOTAL) register indicates the total length of a single scan line, including horizontal retrace time.

Between 0 and H_TOTAL, 6 time events are detected:

1. 1/2 H_TOTAL
2. Horizontal Blank Start
3. Horizontal Alternate Blank Start
4. Horizontal Sync Start
5. Horizontal Alternate Blank End
6. Full H_TOTAL

At 1/2 H_TOTAL (usually about 2/3 across the active display area), the following occur:

1. Refresh Counter Increments (causing a refresh cycle)
2. Vertical Counter Increments (if interlace)
3. Vertical Sync Width Counter Increments (if interlace and VSYNC is active)

The Horizontal Displayed (H_DISP) register specifies the octet at which the internal Horizontal Blank (HBLNK) signal begins. HBLNK is ORed with

Vertical Blank (discussed below) to form the BLANK output signal. HBLNK continues through the end of the scan line (Full H_TOTAL).

VRAM Data Transfer Cycles are triggered by the beginning of HBLNK (delayed by two OCLK cycles). For standard VRAMs, all Data Transfers are initiated in this manner.

The Horizontal Alternate Blank Start (H_AB_STRT) register specifies the octet at which the internal Horizontal Alternate Blank signal begins. Horizontal Alternate Blank is ORed with Vertical Alternate Blank to form the ABLANK/ output signal. The Horizontal Alternate Blank signal ends when the internal horizontal counter equals Horizontal Alternate Blank End (H_AB_END).

The Horizontal Sync Start (H_SYNC_STRT) register specifies the octet at which the output signal horizontal sync (HSYNC) begins. The Horizontal Sync Width (H_SYNC_WID) register specifies the width, in OCLKs, of the HSYNC signal. Using this scheme, an HSYNC may be programmed to start anywhere within a scan line (even at the end), and generate a full pulse width.

Horizontal Sync Polarity (HSYNCPOL), along with Vertical Sync Polarity (VSYNCPOL) bits indicate the current display resolution to IBM compatible monitors:

HSYNCPOL	VSYNCPOL	Resolution
0	0	1024 x 768
0	1	720 x 350
1	0	640 x 400
1	1	640 x 480

At Full H_TOTAL, the scan line ends, and a new one is ready to begin at the left of the screen. The following events take place:

1. Refresh Counter Increments (causing refresh)
2. Vertical Counter Increments (always)
3. Vertical Sync Width Counter Increments (if VSYNC active)
4. Horizontal Blank Ends
5. Vertical Blank and certain other signals synchronize
6. Horizontal Total Counter Resets to Zero



VERTICAL TIMING

The Vertical Counter indicates the vertical scan line currently being displayed. 0 corresponds to the top actively displayed scan line on the screen.

The Vertical Total register (V_TOTAL) indicates the total number of scan lines in a single frame, including vertical retrace time.

Between 0 and V_TOTAL, 5 time events are detected:

1. Vertical Blank Start
2. Vertical Alternate Blank Start
3. Vertical Sync Start
4. Vertical Alternate Blank End
5. Full V_TOTAL

The Vertical Displayed (V_DISP) register specifies the scan-line at which the internal vertical blank (VBLNK) request signal begins. This signal is synchronized as VBLNK only at the ends of horizontal scan lines (see interlace discussion below). After synchronization, it is ORed with HBLNK to form the BLANK output signal. VBLNK continues through the end of the frame (V_TOTAL) when it ends synchronously on full H_TOT.

The Vertical Alternate Blank Start (V_AB_STRT) register specifies the scan-line at which the internal vertical alternate blank request signal begins. This signal is synchronized only at the ends of horizontal scan lines however it is not recommended to use alternate blank in interlaced mode. After synchronization, it is ORed with Horizontal Alternate

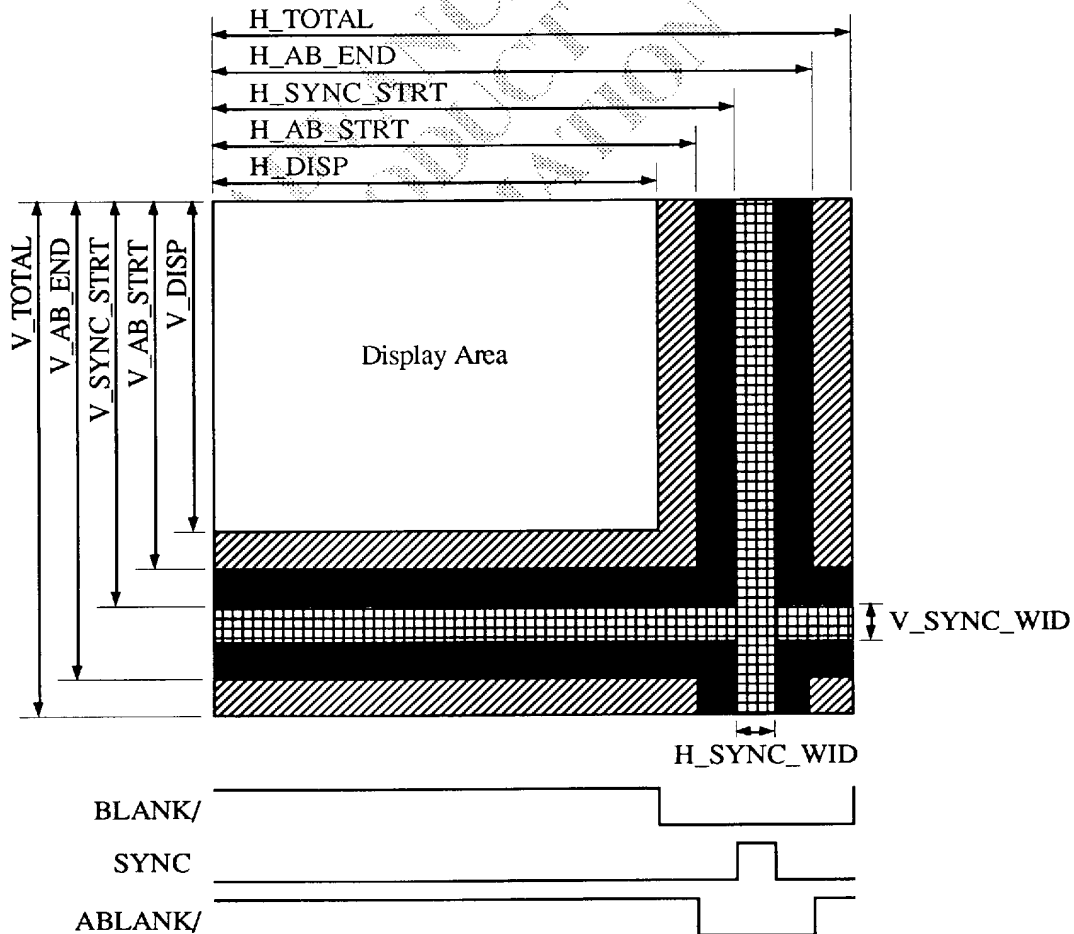

82C481 Video Timing Signals



Blank to form the ABLANK/ output signal. Vertical Alternate Blank continues until the Vertical Alternate Blank End (V_AB_END) register equals the internal vertical counter.

The Vertical Sync Start (V_SYNC_STRT) register specifies the scan-line at which the output signal VSYNC begins. The Vertical Sync Width register (V_SYNC_WID) specifies the width, in scan-lines (or half-scan-lines for interlace) of the VSYNC signal. Using this scheme, a VSYNC may be programmed to start anywhere within a frame (even at the end), and generate a full pulse width.

At Full V_TOTAL, the frame ends, and a new one is ready to begin at the top of the screen. The following events take place:

- 1) Vertical Blank Ends Synchronous to H_TOT
- 2) Vertical Total Counter Resets to Zero

In the V_TOTAL register, bits 11:3 indicate a number of scan lines, multiplied by a scan line modulus defined in the Display Control (DISP_CNTL) register; bits 2:0 of V_TOTAL are an adjustment added to the value in bits 11:3 to allow specifying values that are not an even multiple of the scan line modulus. Bits 11:3 are named Vertical Total Base (VTB) and bits 2:0 are named Vertical Total Adjust (VTADJ).

Similarly, bits 11:3 of V_DISP are named VDB and bits 2:0 are named VDADJ, and bits 11:3 of V_SYNC_STRT are named VSB and bits 2:0 are named VSADJ. If the adjust value is larger than the modulus, the timing is disabled. Actual timings are 1 greater than programmed in the V_TOTAL, V_DISP, and V_SYNC_STRT registers.

The scan line modulus is determined by the Memory Configuration (MEMCFG) and Double Scan (DBLSCAN) bits of the Display Control register, as shown below. MEMCFG is related to the number of banks of VRAMs installed (or the number of scan lines per row address). DBLSCAN = 1 indicates that each scan line is repeated on the display.

MEMCFG	DBLSCAN	Modulus	Notes
0 0	0	2	Indicates PS8 Mode if 512K; Also used for high color modes.
0 0	1	4	Illegal
0 1	0	4	Normal Modes
0 1	1	8	
1 0	0	6	
1 0	1	12	
1 1	0	8	
1 1	1	16	

For example, in 640 x 480 resolution, V_TOTAL = 418h; which after splitting into separate fields is VTB = 83h (131d) and VTADJ = 0. The scan line modulus = 4. The resulting number of scan lines is $131*4 + 0 + 1 = 525$.

For another example, in 640 x 480 resolution, V_DISP = 3BBh which can be separated into VDB = 77h (119d) and VDADJ = 3. The resulting scan line on which BLANK/ goes active is $119*4 + 3 + 1 = 480$, just as expected.

Interlace mode is enabled when the Display Control register INTERLACE bit = 1. Interlace does nothing more than enable the Vertical Counter to count half scan lines rather than full scan lines; all values programmed in interlaced mode must be divided by 2 to get the actual value. For true interlacing to occur, V_TOTAL must be programmed to output an odd number of half scan lines per field. The alternate blank output does not function in interlaced mode.

As an example of interlace, in 1024 x 768 resolution V_TOTAL = 660h, which separates into VTB = CCh (204d) and VTADJ = 0. The resulting number of scan lines per field is $(204*4 + 0 + 1)/2 = 408.5$. The total number of scan lines per frame (two fields) is 817.

As a last example, in 1024 x 768 resolution V_DISP = 5FBh, which separates into VDB = BFh (191d) and VDADJ = 3. The resulting scan line on which BLANK/ goes active is $(191*4 + 3 + 1)/2 = 384$.

Horizontal timing occurs on a full scan line basis only. This means that scan lines have an alternating odd/even relationship with the half-scan-line count in alternate frames. That is, in even frames, the first displayed scan line starts when VCNT = 0. In odd frames, the first displayed scan line starts when VCNT = 1.

On top of the very regular VSYNC period, a slightly irregular VBLANK period occurs. Requests for VBLANK occur on a very regular $N/2 + 1/2$ basis, but they are synchronized only at the ends of horizontal scan lines. This means VBLANK maintains the same odd/even relationship to the half-scan-line count as does the displayed scan lines. This has a side effect that VBLNK for even frames is one scan line longer than VBLNK for odd frames.

REFRESH COUNTER

The Refresh Counter is an independent 9-bit counter which increments every half-scan-line (regardless of interlace mode). Every time its value changes, a VRAM memory refresh cycle is triggered, and the counter value is used as the Row Address.



For refresh to occur, this scheme requires the Video Circuitry to be enabled (using DISP_CNTL[5]). Also, the Horizontal Total register must be loaded with a value such that, with the current NCLK input frequency, the VRAM refresh requirements are met.

SERIAL BUS

Nugget Clock (NCLK) is synchronous to the VRAM serial shift clock frequency, 40 MHz max. It is internally converted to an 8/10 pixel clock (OCLK) by the nugget divisor. OCLK is used by the 82C481 to generate CRT signals HSYNC, VSYNC, ABLANK/, and BLANK/.

The 82C481 chip can select the video clock from up to eight oscillators, using the CLKSEL2:0 outputs. In a pure IBM 8514/A compatible implementation using the 82C481, only CLKSEL0 is needed to select between the 25.175 MHz and 44.9 MHz clocks. In practice the CLKSEL outputs are connected to the select inputs of a ROM based clock synthesis chip (82C403) or a programmable clock synthesizer (82C404).

VRAM Serial Clocks (SCLK1:0) and Serial Output Enables (SOE3:0/) are not generated by the 82C481. They can be generated in discrete logic, or from a Palette chip such as the TLC34075. These signals can also be generated by the 82B484 support chip which provides all of the interface circuitry required between the VRAMs and a 8-bit RAMDAC.

Whenever BLANK/ is inactive; the 82B484 generates SCLK1:0 and SOE3:0/, compensates BLANK/ for serial data pipeline delays, and delivers the palette data and blanking synchronized. SCLK1:0 are stopped during BLANK/, so the next scan line will start on the correct pixel and no VRAM timings will be violated during the data transfer cycle.

There are two basic Video Configurations, A and B. There will of course be variations in external logic, depending on the video frequencies required, and whether the MCA Video Extension or VESA video pass-thru connector (for VGA video) is supported.

Video Configuration A enables data from only one bank at a time and supports video rates up to approximately 125 MHz. Systems using **Video Configuration A** would normally use the 82B484 Video Support Chip for video rates up to 80MHz.

All Memory Configurations but **1M** and its variants use two shift clocks (SCLK1:0) and four output enables (SOE3:0/). SOE3:0/ drive banks 3 to 0 respectively. SCLK0 drives banks 0 and 2, SCLK1 drives banks 1 and 3; SCLK1 and SCLK0 run 180° out of phase at 1/2 the RAMDAC load frequency;

each rising edge of SCLK0 or SCLK1 generates 32/40 bits. SOE0/ and SOE1/ also run 180° out of phase, as do SOE2/ and SOE3/. If there are two banks, Banks 0 and 1 are alternately enabled on 32/40 bit boundaries. If there are four banks, Banks 0 and 1 are alternately enabled on even scan lines; Banks 2 and 3 are alternately enabled on odd scan lines ("odd" and "even" assume non-interlaced screens and count from scan line 0 at the top of the screen). In **Video Configuration A**, serial data from all four banks may be bused together.

Configuration 1M and its variants are a special case, because they use only one bank of VRAM. Only 32/40 bits are output each serial clock cycle, so SCLK0 runs twice as fast in this configuration (no horizontal interleave). SOE0/ is active the entire active display time; SOE3:1/ and SCLK1 are inactive.

Video Configuration B enables video from banks 0 and 1 (or 2 and 3) simultaneously and supports video rates up to about 300 MHz. In this Configuration, SCLK0 still drives Banks 0 and 2 and SCLK1 still drives Banks 1 and 3, but they run in phase, each rising edge producing 64 bits of data. SOE3:0/ still drive Bank 3 through 0 respectively. SOE0/ and SOE1/ are active the entire display time on even scan lines, and SOE2/ and SOE3/ are active the entire display time on odd scan lines. In **Video Configuration B**, serial data from Banks 0 and 2 must be bused separately from Banks 1 and 3 (making the serial data bus 64/80 bits wide).

Video Configuration B may only be used with 2 or 4 banks of VRAM, but Video Configurations are otherwise not related to Memory Configurations. Only Memory Configurations **2M**, **4M**, and their variants are logical candidates for **Video Configuration B**; and only if you need more than the 80 MHz video rate the 82B484 supports.

Another option is to use a RAMDAC™ like the Brooktree Bt484/485 in **Video Configuration A**. These accept 32 bits of data at a time and multiplex the pixels internally. Such palette DACs can support video rates well above 80 MHz and eliminate the need for TTL shift registers. Pseudo 8-Plane mode is not supported by the Bt484/Bt485.

ALTERNATE VIDEO REGISTERS

The 82C481 maintains two alternate video register sets which may be used to force non-standard display parameters when programmed for one of the two standard 8514/A resolutions. They are called the Alternate High Resolution (AHR) and Alternate Low Resolution (ALR) register sets. These alternate



video register sets are intended for use at 1024x768 and 640x480 resolutions respectively. Each of the alternate register sets contains its own copy of the following registers and bit fields:

- | | |
|--------------------------|----------------|
| 1. Horizontal Total | H_TOTAL |
| 2. Horizontal Sync Start | H_SYNC_STRT |
| 3. Horizontal Sync Width | H_SYNC_WID |
| 4. Vertical Total | V_TOTAL |
| 5. Vertical Sync Start | V_SYNC_STRT |
| 6. Vertical Sync Width | V_SYNC_WID |
| 7. MEMCFG | DISP_CNTL[2:1] |
| 8. INTERLACE | DISP_CNTL[4] |
| 9. DBLSCAN | DISP_CNTL[3] |
| 10. CLKSEL[2:0] | EC3[10:8] |

The alternate video registers/bits overlay the I/O locations of the normal registers/bits. The set of registers which is visible to the system is determined by the alternate register select bits (AHRS and ALRS) of register EC3[5:4]. The register set which is active in the 82C481 is determined by the alternate register enable bits (AHRE and ALRE) of register EC3[7:6].

When writing the alternate registers, AHRS and ALRS act as "paging registers" selecting the register sets as follows:

AHRS	ALRS	Selects
0	0	Normal Registers
0	1	Alt. Low-resolution registers
1	0	Alt. High-resolution registers
1	1	Write Protect Video registers

The intention is to load the alternate registers only once, for example under control of a config.sys file. This would then allow the 82C481 to override programs which write the IBM 8514/A values directly to the display registers with values tuned for a specific system. This is useful in systems which have monitors capable of displaying non-interlaced 1024 x 768 resolution or systems requiring a higher vertical refresh frequency than the IBM standard.

The alternate registers are activated by the 8514/A CLKSEL[0] bit in conjunction with AHRE and ALRE as follows:

CLKSEL	AHRE	ALRE	Video Register Active
0	X	0	Normal
0	X	1	Alternate Low-resolution
1	0	X	Normal
1	1	X	Alternate High-resolution

The alternate video registers do not normally need to be saved, however they all are read/write accessible when selected. Note that the CLKSEL0 bit in the

extended configuration register is writeable at both EC3[8] and ADVFUNC_CNTL[2] however it is readable only at EC3[8]. The last data written to ADVFUNC_CNTL[2] is always readable at that location.

Note: Extended Configuration register EC3 should only be written in byte mode. This is because EC3 contains the alternate register selects in its low byte, and several alternate register set bits in its high byte. Writing this register as a word value may yield unpredictable results. Additionally, all extended configuration registers should have reserved bit values preserved. Software should perform RMW operations on these registers. This will allow software to work transparently with future definitions of these bits.



ADVANCE
PRODUCT
INFORMATION



Initialization / Configuration

T-52-33-45

Many aspects of 82C481 operation are configurable. All of these may be selected by hardware strapping options. These strapping options are latched internally at the falling edge of RESET; other functions may be multiplexed over these pins after reset. Options may be set by jumpers; the jumpers are connected to tristate buffers that drive the option pin when enabled by RESOUT/. Most strapping options may be read and written by software, so jumpers may be omitted in favor of a configuration utility. This method combines the best of hardware and software configuration techniques.

Options on the 82C481 are defined so that they all default to a simple 8514/A board configuration. This keeps the 82C481 compatible with its predecessor, the 82C480 which was architected around the IBM 8514/A structure. Most registers, including the extended registers, are always visible to the system (only the alternate blank registers have an enable mechanism).

RESET

On reset, all 82C481 pins except RESOUT/ are tristated.

8BITDAC, ROMCS/, MA8, WE4/, CAS3/2/, CSEL2, FRAME, and P4D7:0 latch configuration options at the falling edge of RESET; they have internal pull-ups to insure they default to 1 unless driven low to select the 0. RDHI/ and RDLO/ have 50K pullups to insure the data transceivers do not drive the system bus during reset. ROMCS/, PALRD/, and RAS/ have 50K pullups to insure the EPROM, RAMDAC, and VRAMs remain in the quiescent state during reset. All internal counters are reset when RESET = 1. Software registers are undefined after reset, unless noted otherwise.

A soft reset may be performed using the Subsystem Control register GPCTRL bits. This has the same effect as a hardware reset, except no pins are tristated, counters are not reset, and configuration options are not loaded.

POS OPERATION

Micro Channel POS_ID (100h-101h) are mapped to on-board ROM. When SETUP/ is active, reads of 100h or 101h activate ROMCS/ [POSEN/] and force ROM_PAGE_SEL[2:0] = 1. This allows any desired POS_ID to be burned in ROM. Boards without ROM may use tristate buffers enabled by POSEN/ to provide a POS_ID.

Register 102H, bit 0 (Card Enable) is implemented in the 82C481 itself. Card Enable is read/write accessible and responds only when SETUP/ is low.

POS registers are accessible as byte registers only and are not accessible in ISA mode.

CONFIGURATION OPTIONS

8/16-bit Bus Interface

The 82C481 configures itself for 8- or 16-bit bus operation. This is possible because BHE/ (SBHE/ on ISA bus) is on the 16-bit bus extension, so it is unconnected when the board is in an 8-bit slot. An internal pullup forces the 82C481 BHE/ pin inactive in this case. A0 and BHE/ are interpreted as follows:

A0	BHE/	MC/ISA Bus Definition	82C481 Definition
0	0	16-bit transfer	16-bit transfer
0	1	Even byte on D7:0	Even byte on D7:0
1	0	Odd byte on D15:8	Odd byte on D15:8
1	1	8-bit adapter	Odd byte on D7:0

Strapping Option - MC/ISA/UISA Bus

SETUP/ is only used in MCA systems; the bus always drives SETUP/ high during reset. SETUP/ may be grounded to select ISA bus interface. For both ISA and MC bus interfaces CSEL2 must be latched high (default) during reset. To select UISA mode, CSEL2 should be pulled low with a 2.2KΩ resistor or tri-state driver enabled by RESETOUT. This selects UISA mode regardless of the state of the ISA/ pin which should be connected to BALE. The bus interface type may not be read by software.

Strapping Option - 1M VRAMs

MA8 is only used by 1Mb VRAMs; if it is 1 on reset 1Mb VRAMs are assumed, if it is 0 256Kb VRAMs are assumed. An internal pull-up makes the pin default to 1Mb VRAMs; drive with RESOUT/ to select 256Kb. This option may be read/written at Extension Configuration register EC2[10]. Only a standard IBM 8514/A memory organization is permitted with 256K VRAMs. No extended color depths or resolutions are supported.

Strapping Option - Number of VRAM Banks

CAS3/ and CAS2/ are only used in configurations of more than 2 banks, so may be used to indicate the number of VRAM banks installed on the board to the 82C481. Internal pullup resistors maintain high



T-52-33-45

levels on these pins if unconnected or used to drive VRAM chip CAS/ inputs. In a 1 bank configuration, both CAS2/ and CAS3/ are tied to RESOUT/; in a 2 bank configuration, CAS3/ is tied to RESOUT/ and CAS2/ is left unconnected; in a 4 bank configuration, CAS2/ and CAS3/ are connected to bank 2 and 3 VRAM chip CAS/ inputs, respectively. The number of VRAM banks may be read/written at Extension Configuration register EC2[9:8].

The number of VRAM banks should be reflected in the VRTCFG and HORCFG bits of the Memory Control register (MEM_CNTL). The least significant bit of HORCFG determines whether 4 or 5 pixel nuggets are used. This bit is related to the depth of the VRAM banks, not the number of banks.

VRT- CFG	HOR- CFG	256Kb VRAM		1Mb VRAM		Notes
		Inter- leave VxH	Total Banks	Inter- leave VxH	Total Banks	
0 0	0 X	1x1	1	n/a	n/a	
0 0	1 X	1x2	2	1x1	1	PS8 Mode
0 1	0 X	2x1	2	1x2	2	
0 1	1 X	2x2	4	1x1	1	8514/A
1 0	0 X	n/a	n/a	2x2	4	
1 0	1 X	n/a	n/a	2x1	2	
1 1	0 X	4x1	4	n/a	n/a	
1 1	1 X	4x2	8	n/a	n/a	

Strapping Option - 8/6 bit DACs

Many VGA boards use the Inmos IMSG176 palette/DAC, which has 6-bit DACs. Other boards may use 8-bit DACs. Still others may use palette/DACs such as the Brooktree Bt478, whose DACs may function as either 8- or 6-bit, depending on the state of their 8/6 input. The 8BITDAC pin is provided for such DACs. There is no pull-up on 8BITDAC; a pull-up or pull-down must be provided to select 8 or 6 bit operation on reset; the state of 8BITDAC on the trailing edge of reset will be latched, and driven back out after reset. 8BITDAC may be read or set by software at Extended Configuration register EC2[13].

Monitor Options

The 82C481 reads analog video SENSE from LM339 comparators, just as VGA chips do, via the SENSE pin. The 82C481 also reads the Monitor ID bits from the Video Connector via pins MS2:0. SENSE may be read from the Display Status register DISP_STAT[0]; Monitor ID bits may be read from the Subsystem Status register SUBSYS_STAT[6:4]. If ROM paging is not used, P4D6 can be tied low and MS2:0 may be connected directly to the the

video connector; if the ROM_PG outputs are used, MS2:0 must be driven by a tristate buffer enabled by RESOUT/. The Monitor ID bits are then read/write in EC3[15:13]. The state of the ROM PAGING bit may be read/written at EC2[6].

Strapping Option - Enable Nibble Mode Signals

To support both a 2048 x 1024 x 4bpp and a 1024 x 1024 x 8bpp frame buffer from 1MB of VRAM the 82C481 implements 8 write enable signals and a pair of CAS signals for bank 0. The 82C481 is backwards (pin) compatible with the 82C480 hence these additional signals default to their 82C480 definitions. To enable these 5 new signals FRAME must be latched low (external pull-down resistor approx 2.2K Ω) on reset.

Other Strapping Options

All remaining options are latched from the pixel bus (P4Dy) on the falling edge of RESET. The P4Dy pixel bus allows 8 possible options, of which only 5 (P4D7-P4D3) are currently implemented. Extension bits currently unused (P4D2-P4D0) are reserved for future definition. Note that these three pins are used as Nibble Mode write enables if configured through the strapping option above. Internal pullups default all of these options to 1.

To select a 0 option, you should drive that pin with a tristate driver (e.g. 74LS244) enabled by RESOUT/. The inputs to these drivers may be grounded for options which will not change, or to jumpers for user selection. For those Px Dy lines which are not to be used by the display buffer, 0 options may be selected by pulling the pin low with a 4.7K Ω resistor. All these options appear in the Extended Configuration Registers and may be read and/or set by software.

Strapping Option - 8 Bit Planes (8BP)

P4D7 = 1 on the falling edge of RESET (default) indicates that 8 planes of VRAM are installed; 0 indicates 4 planes. Emulates the function of a jumper on the 8514/A board. 8PLANE is latched in Subsystem Status register SUBSYS_STAT[7]. 8BP may also be read or written at Extended Configuration register EC2[7].

Strapping Option - ROM Size (ROMSIZE)

If P4D5=1 on the falling edge of RESET (default), an 8K ROM address space is decoded in system memory. If P4D5 is sampled low during RESET, a 32K ROM address space is decoded. The size of the ROM also effects its base address (see the ROM Base Address description below). ROMSIZE may be read or written at EC2[5]. If ROMCS/ is sam-



T-52-33-45

pled low at reset, no ROM is mapped into address space.

Strapping Option - (ROMBASE)

P4D4:3 are latched on the falling edge of RESET to indicate the ROM base address. This configuration option allows all of the ROM address spaces in system memory to be relocated in case of address conflicts. Address conflicts are possible with any number of peripheral adapters. ROMBASE may be read or written at EC2[4:3]. Care must be taken when writing EC2 not to destroy the configuration information contained therein.

ROMBASE	8K MC	8K ISA	32K
0 0	C8000h	C6000h	D0000h
0 1	D8000h	D8000h	D8000h
1 0	C0000h	C0000h	C0000h
1 1 (default)	C6000h	C8000h	C8000h

ADVANCE
PRODUCT
INFORMATION



ADVANCE
PRODUCT
INFORMATION



Pixel Operations

T-52-33-45

MIXES

The 82C481 supports 30 mixes, or raster ops. These are selected by the FOREMIX bits of FRGD_MIX or the BACKMIX bits of the BKGD_MIX register, as shown in the table below. In addition to all 16 possible 2-operand logical mixes, there are 14 arithmetic mixes including min, max, average, sum, and difference (either SRC - DST or DST - SRC). Sum, difference, and average may be saturating (i.e. no sum can be greater than FFh and no difference can be less than 0) or allow overflow (sum and average) and underflow (difference). Saturation prevents unexpected visual results. A fixed or variable (supplied by the host) pattern may be applied to any drawing operation. Only the logical mixes are available to the 16bpp and 32bpp high color modes.

MIX	RESULT
0h = 00000b =	~DST
1h = 00001b =	0
2h = 00010b =	1
3h = 00011b =	DST
4h = 00100b =	~SRC
5h = 00101b =	SRC ^ DST /* XOR */
6h = 00110b =	~(SRC ^ DST)
7h = 00111b =	SRC
8h = 01000b =	~(SRC * DST) /* NAND */
9h = 01001b =	~(SRC * ~DST)
Ah = 01010b =	~(~SRC * DST)
Bh = 01011b =	~(~SRC * ~DST) /* OR */
Ch = 01100b =	SRC * DST /* AND */
Dh = 01101b =	SRC * ~DST
Eh = 01110b =	~SRC * DST
Fh = 01111b =	~SRC * ~DST /* NOR */
10h = 10000b =	min(SRC,DST)
11h = 10001b =	DST - SRC with underflow
12h = 10010b =	SRC - DST with underflow
13h = 10011b =	SRC + DST with overflow
14h = 10100b =	max(SRC,DST)
15h = 10101b =	(DST - SRC)/2 with underflow
16h = 10110b =	(SRC - DST)/2 with underflow
17h = 10111b =	(SRC + DST)/2 with overflow
18h = 11000b =	DST - SRC with saturate
19h = 11001b =	DST - SRC with saturate
1Ah = 11010b =	SRC - DST with saturate
1Bh = 11011b =	SRC + DST with saturate
1Ch = 11100b =	(DST - SRC)/2 with saturate
1Dh = 11101b =	(DST - SRC)/2 with saturate
1Eh = 11110b =	(SRC - DST)/2 with saturate
1Fh = 11111b =	(SRC + DST)/2 with saturate

SOURCE OPERAND SELECTION

The destination operand (DST) always comes from the bitmap. However, the source operand (SRC) can come from one of four places based on the Foreground or Background Source Select (FSS or BSS) fields. FSS and BSS are decoded identically, only FSS is shown below:

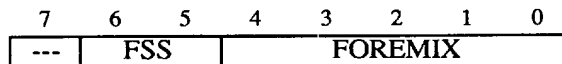

FSS	Foreground Source Select
0 0	Background Color (BKGD_COLOR)
0 1	Foreground Color (FRGD_COLOR)
1 0	Variable Pixel Data (PIX_TRANS)
1 1	Bitmap Data

The Background Color (BKGD_COLOR) and Foreground Color (FRGD_COLOR) are register values, used to draw in a solid color or pattern of two solid colors. The FRGD_COLOR and BKGD_COLOR registers are always the same depth as the pixels (ie. in 16bpp mode these registers are 16 bits wide and in 32bpp mode 32 bits wide).

Pixel Transfer (PIX_TRANS) is provided by/to the host, one byte per pixel or nugget (see Across Planes vs Through Planes, below). This allows applying any arbitrary pattern to a drawing operation, or copying data to/from system memory.

Bitmap data is from the source rectangle of a CMD_BITBLT command. This Source Select should only be used for the CMD_BITBLT command; results are undefined for other commands. Bitmap data is commonly referred to as "source" data, but should not be confused with "SRC" data, which is an ALU operand selected by either BSS or FSS. If FSS and BSS = 11, the terms "source" and "SRC" are equivalent.

FOREGROUND AND BACKGROUND

The 82C481 supports two Source Select/Mix pairs: Foreground and Background. The Foreground Source Select (FSS) is always used with the Foreground Mix (FRGD_MIX), and the Background Source Select (BSS) is always used with the Background Mix (BKGD_MIX). The combination of Foreground Source Select and Foreground Mix will be referred to simply as the Foreground; the combination of Background Source

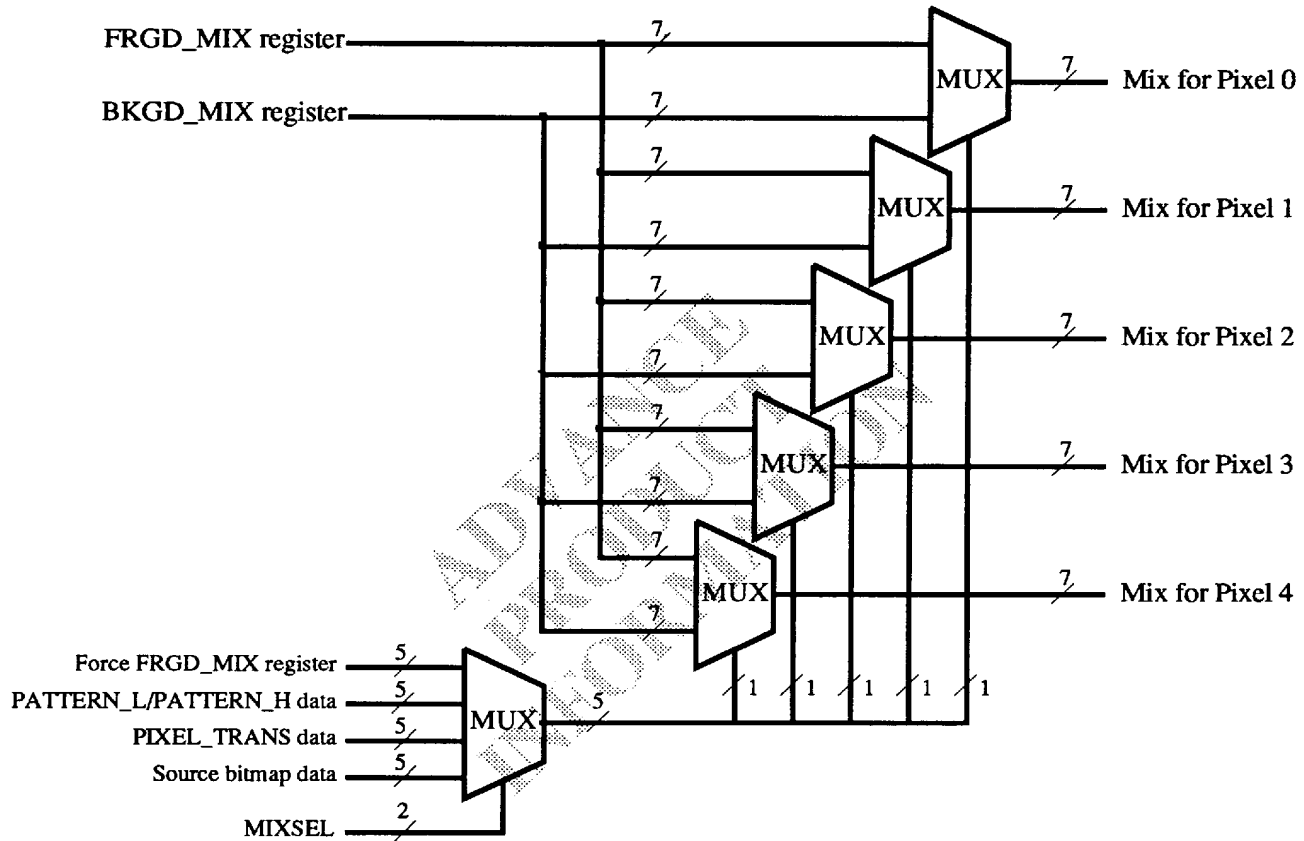

Mix Select for each Pixel Drawing Engine



Select and Background Mix will be referred to as the Background. There are also registers for the Foreground Color (FRGD_COLOR) and Background Color (BKGD_COLOR); these are not associated with the Foreground and Background mix. The Foreground Mix may select either Foreground Color or Background Color, and similarly for the Background Mix. "Foreground Color" and "Background Color" are just words used to distinguish between the two color registers.

Whether the Foreground or Background is used is determined on a pixel-by-pixel basis; even though the Memory Controller operates on up to four or five pixels at a time, each pixel Arithmetic Logic Unit (ALU) can independently use the Foreground or Background.

Foreground Select Mode

In one further level of indirection, there are four possible methods of selecting Foreground vs. Background, chosen by the mix select (MIXSEL) bits (PIX_CNTL[7:6]). MIXSEL applies to all ALUs.

Mix Select Mode (MIXSEL):

- 0 0 = Foreground is always used (most common value)
- 0 1 = Pattern Array or PAT_L/PAT_H select Foreground (1 selects FRGD_MIX)
- 1 0 = VAR (PIX_TRANS Variable data) selects Foreground (1 selects FRGD_MIX)
- 1 1 = Transparency selects Foreground

If MIXSEL = 00 (most commonly used option), the Foreground is always selected.

If MIXSEL = 01, and PAT (EC1[10]) = 0, PATTERN_L (PAT_L) and PATTERN_H (PAT_H) select Foreground. PAT_L and PAT_H are both 4 pixel-wide registers; PAT_L is used for the first 4 pixels in an octet (starting with octet 0 at the left of the screen), and PAT_H for the high 4 pixels of the octet. Bits (0), 1, 2, 3, and 4 of PAT_L and PAT_H control pixels (4), 3, 2, 1, and 0 on the screen respectively (SPN=1). These allow applying a fixed destination-aligned pattern. It may be a pattern of the Foreground and Background Color, or a pattern of Foreground and Background Mixes. To apply a 2D pattern, PAT_L and PAT_H must be reloaded on each scan line; there is no interrupt mechanism to prompt for reloading.

If PAT (EC1[10]) = 1, then a 2-D pattern can be applied using the 8 x 8 pattern array. The pattern array is loaded by 8 I/O writes to PAT_L[7:0]. Like the PAT_H/PAT_L registers, the pattern array is destination aligned.

If MIXSEL = 10, PIX_TRANS selects Foreground. PIX_TRANS is the variable data from the host. Bits (0), 1, 2, 3, and 4 control pixels (4), 3, 2, 1, and 0 of the destination respectively (SPN=1). This

operation is described as 'across the planes'.

In 16bpp and 32bpp modes the PIX_TRANS information is transferred in a different manner. PIX_TRANS across planes painting only works for X-RECT commands. Additionally, the across planes data can only be passed in 16 bit PIX_TRANS mode (_16BIT = 1). Any PIX_TRANS data remaining at the end of each scan line is discarded. (In 4bpp and 8bpp modes if one byte of the PIX_TRANS word is unused it is wrapped to the first byte of the next scan line).

If MIXSEL = 11, transparency selects Foreground. Transparency is 1 (true) if source data = 1 for every bit where RD_MASK = 1. RD_MASK is rotated right one bit for purposes of transparency comparisons. This is to allow the RD_MASK to specify different planes for transparency and area filling operations. If transparency is true, the Foreground is selected; otherwise the Background is selected. Source data is stored in the scratch register during the bitblt (see next section); the result of the transparency test is stored in place of bit 7 of the source. Transparency does not function correctly in 16bpp and 32bpp modes except for stretch bitblts as described below.

MIXSEL = 11 is used to allow "source transparency". Typically, one bit plane is designated as the transparency plane. If that bit is 1, the destination is left unmodified. Visually, the source data appears "transparent" for that pixel (i.e. after copying the source, you still see the old destination data at that pixel).

Should you select MIXSEL = 11 and FSS and/or BSS = 11 (SRC is bitmap data), you would expect to see the source data written to the destination at all the appropriate places. This is not quite what happens, because the foreground select bit overwrites bit 7 of the source, so instead of seeing the source written to the destination, you see the source with bit 7 modified.

MIXSEL = 11 is also used to do a stretch blt--i.e., a bitblt where the source data is stored in only one plane, and during the course of the bitblt it is expanded to eight planes. This is done by selecting (for example) MIXSEL = 11, FSS = 01, FOREMIX = 7, BSS = 00, BACKMIX = 7, and RD_MASK = 01h. In this case, the source is a monochrome image stored in plane 7 (selected by RD_MASK >> 1 = 80h); every pixel where bit 7 = 1, is drawn in Foreground Color, and every pixel where bit 7 = 0 is drawn in Background Color.

In 16bpp and 32bpp modes stretch blts function in a slightly different manner. The RD_MASK and WR_MASK are expanded to 16/32 bits. The rotation of the RD_MASK occurs as a byte rotation similar to the 8bpp mode, not as a rotation of a 16 or 32 bit word. For example when using 32bpp mode to produce a 24bpp display, 8 planes are available



T-52-33-45

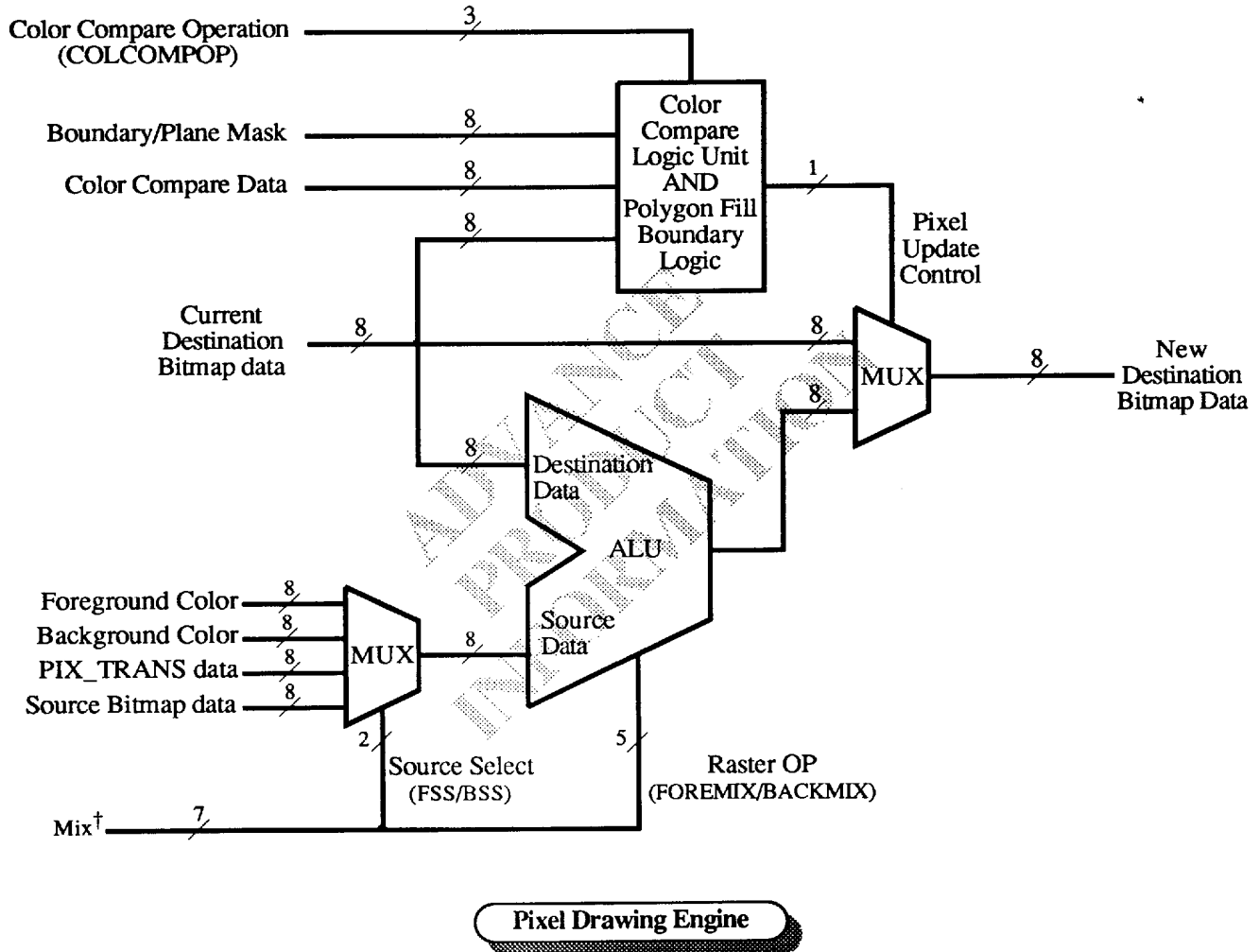

† This Mix comes from one of the 5 individual pixel mixes shown in the diagram on the previous page.



beneath the display for caching fonts. To select plane 31 the RD_MASK would be written as 00,00,00,01 which when rotated produces 00,00,00,80h.

Stretch blts are used for drawing bitmapped characters. Character fonts may be cached with a different character in each plane to conserve memory, and then drawn in the current foreground color. By selecting the mixes, the character cell may be opaque (i.e. Foreground or Background Color) or transparent.

COLOR COMPARISON

The 82C481 can do a magnitude comparison of the destination data to a fixed reference color, stored in the Color Comparison register (COLOR_CMP). If the comparison is true, the destination is left unchanged; if false, the drawing operation operates normally. The effect is that certain color(s) in the destination (i.e. "background") appear in front of the source (i.e. "foreground"). IBM refers to this operation as underpainting, meaning that the source pixels appear to be painted under the destination data. The 16bpp and 24bpp high color modes only support the COLRCMPOP's "=", "0" and "1". The COLOR_CMP register is the same depth as the pixel format in all cases.

Note that Color Comparison compares the destination data to a reference color; this is different than transparency (above), which tests the source data; the 82C481 does both.

The type of magnitude comparison between COLOR_CMP and DST is determined by the COLCMPOP bits of the Pixel Control register (PIX_CNTL[5:3]), as defined below:

COLCMPOP			Comparison	Notes
5	4	3		
0	0	0	0	Always false
0	0	1	1	Always true
0	1	0	DST >= C_CMP	Not equal
0	1	1	DST < C_CMP	
1	0	0	DST ≠ C_CMP	
1	0	1	DST = C_CMP	
1	1	0	DST <= C_CMP	
1	1	1	DST > C_CMP	

By selecting the proper mixes, the Color Comparison logic can implement a Color Exchange operation: all pixels of a specified color are replaced by a different color. This Color Exchange will be done on a rectangle defined by the Clipping Rectangle, or on a Polygon, as defined in Polygon Fill.

PLANE MASKS

The 82C481 has two host-writable plane mask registers: Plane Read Mask (RD_MASK) and Plane Write Mask (WRT_MASK). The 82C481 generates a third, the Plane Mix Enable (PME) under control of the PLANEMODE bits (PIX_CNTL[2:1]). If PLANEMODE = 10, PME = WRT_MASK * ~RD_MASK; else PME = WRT_MASK. The mask registers are the same length as the pixel depth.

A 0 in WRT_MASK always prevents writing the corresponding plane in memory, using the VRAM write-per-bit capability. A 0 in PME always prevents the corresponding planes from taking part in any mix (i.e. raster op); results are not specified for arithmetic mixes where a non-contiguous set of planes is enabled by PME.

The function of RD_MASK is more complicated:

During variable data read cycles, RD_MASK can determine which planes are read by the host depending on the value of the PLANEMODE bits. If PLANEMODE = 00, then the RD_MASK register has no effect on the data transfer. This is useful for reading the entire bitmap in Through Plane mode (PLANAR=0).

If PLANEMODE = 10 or 11, the pixel data returned should be read back in Across Plane mode (PLANAR=1). The RD_MASK is rotated right one bit and a logical test is performed between the rotated RD_MASK and bitmap data. Those pixels which have 1s in all planes where rotated RD_MASK = 1 return a 1. Because the data is returned in Across Planes mode, the drawing engine is moving 32 bits at a time and the data read back will be nugget aligned. This is useful for reading just one plane or color pattern. This operation does not function correctly in 16bpp or 32bpp modes.

In the read phase of a Copy Rectangle (CMD_BITBLT) command, when MIXSEL = 11 (Bitmap data selects Foreground), RD_MASK selects which planes to use to determine if the source is transparent. Those pixels which have 1s in all planes where RD_MASK = 1 are transparent. Plane 7 in the Scratch Register (see below) is used to store the transparency result, so only 128 colors are available when doing this operation.

In both cases above, RD_MASK is rotated right one bit before being used.

During Polygon Fill, the PLANEMODE bits determine the Boundary Mask. The Boundary Mask selects which plane(s) will describe the boundary of the polygon. Pixels which have 1s in all planes



where RD_MASK = 1 are boundary pixels. In this case, RD_MASK is not rotated. RD_MASK bit Functions:

RD MASK	Enabled Plane	
	Variable Data Read	Polygon Fill
0000 0001b	7	0
0000 0010b	0	1
0000 0100b	1	2
0000 1000b	2	3
0001 0000b	3	4
0010 0000b	4	5
0100 0000b	5	6
1000 0000b	6	7

The following table shows the mask values for the two area fill operations:

PIX CNTL [2:1]	Boundary Mask	Plane Mask
1 0	RD_MASK	WRT_MASK * (~RD_MASK)
1 1	WRT_MASK	WRT_MASK

ACROSS PLANES vs. THROUGH PLANES

In Pixel Data write mode (PCDATA = WRTDATA = 1), the 82C481 will stop before drawing each pixel (or nugget) for the host to write data in the Pixel Data register (PIX_TRANS). In Pixel Data read mode (PCDATA = 1, WRTDATA = 0), the 82C481 will stop after reading each pixel (or nugget) for the host to read data from PIX_TRANS. PCDATA = 1 applies to all drawing operations, including lines and short stroke vectors. This allows drawing lines using any arbitrary user-defined line pattern.

When PCDATA = 1, Pixel Data may be read/written across planes (AP) or through planes (TP).

In TP mode (PLANAR = 0), each byte of PIX_TRANS is interpreted as an 8-bit value representing up to eight planes of a single pixel (four planes in 4bpp mode). When doing bitblts in this mode, the 82C481 handles data just one byte at a time, not 32 bits at a time.

In TP pixel data read mode (PLANAR = 0, PCDATA = 1, WRTDATA = 0), the drawing engine waits to write the source pixel to PIX_TRANS before moving on to the next pixel. If necessary, it will wait for the host to read the last pixel from PIX_TRANS. In 4bpp and 8bpp mode, each byte of PIX_TRANS is written to the respective plane of two pixels. In 16bpp mode, the bytes form a single pixel. For 32bpp modes, two consecutive I/O writes to PIX_TRANS form a single pixel. The byte steering in high color modes is the same as for 4bpp

and 8bpp modes. The only command which supports TP high color data is CMD_RECT.

In TP pixel data write mode (PLANAR = 0, PCDATA = WRTDATA = 1), the drawing engine waits to receive a new PIX_TRANS byte from the queue before drawing each pixel. What effect PIX_TRANS has on the pixel operation is determined by the mix select (MIXSEL) field (PIX_CNTL[7:6]), and the mix registers (FRGD_MIX and BKGD_MIX). It is entirely possible that PIX_TRANS has no effect on the pixel operation at all, but the drawing engine still must receive pixel data from the host before it will proceed.

In AP mode (PLANAR = 1), PIX_TRANS is interpreted as a four/(five) bit quantity, where each bit controls one pixel. PIX_TRANS bits (0),1, 2, 3, and 4 control pixels (4),3, 2, 1, and 0, respectively. WRT_MASK can be used to control which bit planes are modified. AP mode should not be used with line draw and SSV commands, because these commands inherently operate on pixels, while AP mode works on nuggets, and results are difficult to predict. For high color modes AP write mode can only be used with CMD_RECT.

In AP pixel data read mode (PLANAR = PCDATA = 1, WRTDATA = 0), PIX_TRANS bits (0)/1 through 3 contain the transparency result of pixels (4)/3 through 0 of the last nugget read. The Plane Read Mask (RD_MASK) register can be used to select which planes participate in the transparency test. AP read mode does not work for high color 16bpp or 32bpp modes.

In AP pixel data write mode (PLANAR = PCDATA = WRTDATA = 1), each of PIX_TRANS bits (0)/1 through 3 selects foreground/background for pixels (4)/3 through 0 of the current nugget if MIXSEL = 10. If MIXSEL ≠ 2, PIX_TRANS has no effect on pixel operations, but the drawing machine still waits for a new PIX_TRANS byte before proceeding.

To improve performance in either AP or TP modes, PIX_TRANS data may be read/written two nuggets or pixels at a time by selecting 16-bit mode (_16BIT = 1). In this mode, PIX_TRANS is treated as a 16-bit register, and needs to be read/written only half as often. This is required for high color modes.

Also to improve performance, writes to PIX_TRANS are queued; this allows writing up to 32 bytes in advance. Reads from PIX_TRANS are not queued. See separate Queue section for details of Queue operation.

SCRATCH REGISTER

During the source phase of a Copy Rectangle (CMD_BITBLT) command, up to eight 32-bit words



are read into the Scratch Register. Data words are read using page mode cycles (bank-interleaved page mode if there are two or four banks). Pixel alignment is done as the data is written into the scratch register. If the source is nugget-aligned, all reads are done in 32-bit mode; if the source is not nugget-aligned, the edges are read in byte mode, and the interior is read in nugget mode.

T-52-33-45

During the destination phase of the Copy Rectangle command, data is read from the scratch register, combined with the destination data as specified by the FOREMIX or BACKMIX, and written back to the destination address. If the Mix is a function of the destination data, page-mode RMW cycles are used, otherwise simple page-mode write cycles are used. If the destination is nugget-aligned, all writes are done in 32-bit mode; otherwise the edges are written in byte mode and the interior of the rectangle is written in nugget mode.

ADVANCE
PRODUCT
INFORMATION



T-52-33-45

ADVANCE
PRODUCT
INFORMATION

Drawing Operations

T-52-33-45

The 82C481 supports 6 different drawing algorithms, including 2 for lines and 4 for rectangles. These algorithms define the motion from the current XY position, and are executed in the "drawing engine" circuitry. Other circuitry, the ALU, selects whether certain pixels or image planes are written, which color is written, etc. Marking of pixels takes place only inside the scissor rectangle; the drawing operation proceeds even outside the rectangle, but WE4:0/ are inhibited so no pixels are marked. (The scissor rectangle is defined by the XY coordinates programmed in the four SCISSORS registers).

The choice between Through Planes and Across Planes modes is important for the execution of the drawing algorithms. In general, TP mode is needed only to copy data between system memory and the bitmap. TP mode is relatively slow, requiring that each pixel be accessed in its own VRAM cycle. Most algorithms work faster in AP mode, since a whole doubleword (32 or 40 bits) may be accessed in a single VRAM cycle.

The drawing engine can take advantage of AP mode by invoking nugget mode. In this mode, the current X coordinate (CUR_X) can be moved as much as 4 pixels (4bpp/8bpp modes) in one machine cycle (a "machine cycle" is the basic cycle of the geometry state machine). Byte mode requires 4 machine cycles per nugget (even though the entire nugget could be written in one VRAM cycle). Some algorithms (Fast Fill and the Source pass of the Copy Rectangle) assume nugget mode, whereas others invoke it only when appropriate.

The selection of Pixel Data, using the PCDATA bit, controls the geometry engine only. It causes VRAM accesses to be limited by the transfer rate of Pixel Data across the system bus. That is, one byte of Pixel Data enables 1 VRAM access (either byte or nugget!). PCDATA does not control whether Pixel Data is used as an ALU control or data source! The Mix (FRGD_MIX, BKGD_MIX) and Pixel Control (PIX_CNTL) registers control these aspects.

Note that AP Pixel Data mode for Bresenham lines is tricky if not impossible to implement. This is because each new byte of Pixel Data triggers one VRAM memory cycle. Since every Bresenham "bump" to a new scan line requires a new memory cycle, and since it is difficult to determine how many pixels will appear on each scan line, it is difficult to

synchronize AP Pixel Data bytes with Bresenham drawing. Instead use TP mode.

Command Port bits INC_X and INC_Y effect the starting corner of the rectangle/line. If neither is set, the starting corner is the lower right. If INC_Y is set and INC_X is not, drawing starts in the upper right corner. All algorithm discussions below assume both bits are set, and drawing starts in the upper left corner.

LINE

The 82C481 Line command uses the Bresenham algorithm. Bresenham, like most Digital Differential Analysis (DDA) algorithms, first determines the major or independent axis (if the line were projected onto the X and Y-axis, the independent axis is the one with the longer projection). The major axis coordinate (X or Y) is the independent coordinate. The slope of the line is calculated for the other (dependent) coordinate as a function of the independent coordinate. For each pixel drawn the algorithm increments (or decrements) the independent coordinate, and adds the slope to the dependent coordinate, and if the fractional remainder (the error term) is greater than 0.5, the dependent coordinate is incremented; otherwise it stays the same.

The method above requires a division to compute the slope. This division can be avoided, however, since the algorithm is unaffected by multiplying by a constant.

The algorithm may be expressed by the C pseudo-code on the following page. The major axis is indicated by the 82C481 Y Major Axis (YMAJAXIS) bit; if YMAJAXIS = 1, Y is the major axis. Before drawing the line, the image space is decomposed into eight octants, and the octant in which the line is drawn is encoded by the INC_Y, YMAJAXIS, and INC_X bits (CMD[7:5]).

SSV DRAWING

Short Stroke Vector (SSV) is another line drawing function. SSV involves much less overhead than Line Draw (CMD_LINE); only one byte is required per vector, compared to four (or more) 16-bit words per vector if drawn by the Line command. Two SSVs may be generated with a single 16-bit write to the SSV Register. This lends itself well for character/text drawing.



/* 82C481 Implementation of Bresenham algorithm.

T-52-33-45

The following registers must be initialized by software before issuing a CMD_LINE command:

CUR_X	=	Initial x-axis coordinate
CUR_Y	=	Initial y-axis coordinate
MAJ_AXIS_PCNT	=	Length of line projected onto major axis (dmajor)
DESTX_DIASTP	=	2*dminor - 2*dmajor
DESTY_AXSTP	=	2*dminor
ERROR_TERM	=	2*dminor - dmajor

Where:

dminor	=	length of minor axis projection
dmajor	=	length of major axis projection

*/

```

CMD_LINE()
{
  int  xstep,ystep;
  if (INC_Y) {ystep = 1} else {ystep = -1}
  if (INC_X) {xstep = 1} else {xstep = -1}
  for (i=0; i < MAJ_AXIS_PCNT; i++)
  {
    plot(CUR_X,CUR_Y); /* Plot the pixel at the current x,y position */
    if (ERROR_TERM > 0)
    {
      CUR_X += xstep; /* Make a diagonal step */
      CUR_Y += ystep;
      ERROR_TERM += DESTX_DIASTP;
    }
    else
    {
      /* Make a linear step */
      if (YMAJAXIS) {CUR_Y += ystep} else {CUR_X += xstep};
      ERROR_TERM += DESTY_AXSTP;
    }
  }
}

```

Bresenham Algorithm Implementation

When using SSVs, the Command Register must first be set for no drawing command (CMD_NOP) and Short Stroke Vectors Enabled (LINETYPE = 1). LASTPIX and BYTSEQ Command Register bits are used by the SSV command. After the Command Register is set, a series of SSV drawing orders may be written to the SHORT_STROKE Register. This series may be padded with Null SSV bytes (all 0's).

Each SSV specifies a length (0 to 15 pixels), a direction (multiple of 45°), and a bit to indicate whether the SSV is drawn (visible) or not (invisible).

In all SSVs, the Current Position (CUR_X,CUR_Y) is moved from the starting position to a position which is N pixels (Length) away from the starting position, in the direction specified. A length of "0" will cause no movement. If drawing is not specified (SSVDRAW=0), no writes to memory are performed.

If drawing is specified, writes to memory take place as the current position is moved. The first pixel is always drawn at the Current Position. If LASTPIX is set, N pixels are written. If LASTPIX is not set, N + 1 pixels are written. If LASTPIX = 1 and LENGTH = 0, one pixel is drawn at the Current Position.

See the SSV register description for more details.

RECTANGLE

The 82C481 has one form of bitblt called Copy Rectangle (CMD_BITBLT), and three forms of rectangle fill called Fast Rectangle (CMD_RECTV2), Rectangle X (CMD_RECT), and Rectangle Y (CMD_RECTV1). Each of these is selected by the Draw Command bits in the Command Register CMD[15:13]. Only the CMD_RECT and CMD_BITBLT can be used in high color modes.



Copy Rectangle

The Copy Rectangle (CMD_BITBLT) command is a 2-pass algorithm used for copying one region of image bitmap memory into another in foreground or background.

In TP mode, it may also be used to conditionally blit system memory data into the Destination rectangle, contingent upon Source rectangle data. This setup would require PLANAR = 0 and MIXSEL = 11. This is not a standard usage of Through Plane mode according to IBM. This usage implies switching between Foreground and Background Mixes (based on Source data).

The first pass of the algorithm reads data from the Source image bitmap rectangle into the scratch register. The motion algorithm used for reading is identical to the Rectangle X algorithm in Across Plane mode (below) taking advantage of Nugget mode when possible. During this pass, pixel data is realigned through a barrel shifter into its Destination Intra-Nugget Pixel Position (INPP) alignment. The ALU is not used in this pass. If Command register DRAW bit (CMD[4]) is clear, Pixel Data may be read from the Source rectangle during this pass, but Across Planes is the only viable format. Data read this way is in the original INPP alignment, not realigned.

The second pass of the algorithm writes data from the scratch register into the Destination rectangle. The ALU is used to mix the Destination data with Pixel Data (if TP = WRTDATA = 1), Fixed Data, or Source Data, as chosen by the Mix. The algorithm used is identical to Rectangle X, using either Across or Through Plane mode. Across Plane mode is the fastest mode, using 1 bit-per pixel Variable Data (if AP = WRTDATA = 1), Pattern Register Data, or Source Data as the Mix select. The Color Comparators may be used to control Underpaint in 4bpp and 8bpp modes.

Fast Rectangle

CMD_RECTV2 uses a left-to-right alternating up-down sweep algorithm, and always draws a nugget at a time where possible. This is not the fastest rectangle command, but it is the faster of the two Y-direction rectangle commands. This command should not be used in high color (16bpp/32bpp) modes.

If the left edge of the rectangle is nugget-aligned, drawing starts in nugget mode. Otherwise, drawing starts as follows: drawing starts in pixel mode at the upper-left corner of the rectangle. One pixel at a time

is drawn, going to the right until a nugget boundary is reached; a maximum of three pixels (four for five-pixel nuggets) are drawn this way. Drawing proceeds downwards, drawing one partial nugget at a time until the bottom of the rectangle is reached. The write enables are used to write only the pixels of the nugget that fall inside the rectangle. The Current Position moves right to the next nugget, and drawing proceeds upwards in nugget mode. Drawing continues in nugget mode, alternating up and down directions, until the right edge of the rectangle to be drawn is less than a nugget wide.

If the right edge of the rectangle is nugget-aligned, drawing ends in nugget mode. Otherwise, the right edge is drawn exactly as described above for the left edge; one pixel at a time, until the right edge of the rectangle is reached.

Fast Rectangle assumes Across Plane operation. The selection of Across Plane or Through Plane modes by the PLANAR Command register bit is ignored.

X-Rectangle

The Rectangle X (CMD_RECT) drawing command is used for drawing or reading a rectangle in a horizontal orientation. This may be used in either TP or AP modes. In TP mode, it may be used most effectively for copying Variable Data between system memory and image memory. In AP mode, it is the fastest drawing command for large area fills, since it makes optimum use of page mode. It is also the drawing command used for area fills and floods (see below).

Motion starts in the upper left-hand corner of the rectangle (assuming INC_X and INC_Y are set in the command register), and proceeds to the right. Once the right end of the rectangle is reached, the Y position is incremented, and X position is reset to the left edge of the rectangle. Motion then repeats as in the first row, continuing until the whole rectangle is drawn.

When a full nugget can be written, this drawing algorithm will take full advantage of "nugget mode". All pixels within the nugget will be drawn by the drawing engine in one machine cycle. Otherwise, pixels in less than full nuggets (e.g. at the left and right edges or rectangles) will be drawn in "pixel mode", accumulating Write Enables one pixel at a time. In 4bpp mode using 1M (2048 x 1024 x 4bpp) nugget mode operates 4 pixels at a time since it is limited by the number of ALU's internal to the 82C481.



Nugget mode is never used in TP mode, because TP requires one memory cycle per pixel.

Y Rectangle

Rectangle Y (CMD_RECTV1) is used for drawing or reading a rectangle one pixel at a time in a vertical orientation. This type of drawing motion is useful for TP data manipulation, particularly copying Pixel Data between the system memory and bitmap when the data is vertically oriented. While it may be used in AP mode, it offers no speed advantage. Motion starts in the upper left-hand corner of the rectangle (assuming INC_X and INC_Y are set in the Command register) and proceeds downward in a 1-pixel-wide column. Once at the bottom of the rectangle, the X position is moved right by one pixel, and the Y position is reset to the top of the rectangle. This motion repeats for all columns, and the process continues until the whole rectangle is drawn. This command can be used in 8bpp and 4bpp modes.

POLYGON FILL

The 82C481 contains hardware to perform Polygon Fills using the CMD_RECT command with the proper PLANEMODE bit values. Polygon Fill is defined as filling an arbitrary area using any available mix, where the area is defined by a continuous boundary of the specified boundary color(s). The area may be concave or contain holes, and is filled using an "odd/even" algorithm. The area is filled by setting up a destination rectangle which encloses the polygon, setting PLANEMODE = 1Xb, and performing a CMD_RECT command. The 82C481 fills the polygon in AP mode, four pixels at a time, at full speed. Polygon fill only works in 4bpp and 8bpp modes.

Inside detection is done by defining the left edge of the destination rectangle as "outside". For each scan line, each time a pixel of the boundary color is crossed, the inside/outside state is toggled. The 82C481 can handle multiple inside/outside transitions per nugget.

There are two methods of defining the boundary color(s), selected by PLANEMODE bit 0:

If PLANEMODE[0] = 0, the boundary is defined to be those pixels having 1s in all bit positions where there are 1s in the Plane Read Mask (RD_MASK). The Plane Mask applied during the fill operation is:

$$\text{Plane Mask} = \text{WRT_MASK} * \sim(\text{RD_MASK})$$

Usually, a single plane would be used to mark the boundary, and if this plane is masked off from the

palette, the boundary would be invisible; this limits the system to 128 colors. When filling the polygon, the left boundary is marked but not the right; this allows producing a filled polygon that is only one pixel wide.

If PLANEMODE[0] = 1, the boundary is defined to be those pixels having 1s in all bit positions where there are 1s in the Plane Write Mask (WRT_MASK) register. For example, if WRT_MASK = FFh, the boundary would be marked in color FFh. The Plane Mask applied during the fill operation is:

$$\text{Plane Mask} = \text{WRT_MASK}$$

When filling the polygon, both the right and left boundaries are overwritten with the selected color. The advantage of this method is it does not require a separate plane to mark the boundary, so it is the only one that works with a 256 color system.

To facilitate drawing outlines of areas, the 82C481 provides an Outline command. This is similar to the Line command, but after drawing the first pixel of the line, it draws a pixel only when the Y coordinate increments. This produces a boundary of the enclosed area which is compatible with the Area Fill algorithm. Area filling may produce the wrong results if the boundary is self-intersecting. Using XOR mix with the Outline command will eliminate some errors, but not all. Careful orientation of the outline commands can ensure a correct result. The high color modes are not supported by the Outline command.

There is a variation of the area fill function which may be called the Fill/BitBlit. This allows a BitBlit to be done to the interior of a polygon. The Fill/BitBlit uses the RD_MASK and WRT_MASK exactly the same as the standard Fill operation.

TEXT MODES

There is no hardware text mode as in the VGA. The IBM 8514/A Adapter Interface (AI) supports two types of fonts: bitmapped fonts and stroke fonts. Bitmap fonts are stored in system memory as bitmaps, and stroke fonts are stored as a sequence of SSVs. The AI maintains a most-recently-used cache of four fonts of either type in a non-displayed area of the bitmap. If the character is in the cache, it can be drawn by just blitting (stretch blit); if it is not cached, the AI takes care of generating an image of the character and adding it to the cache.

Application Schematic Examples

This section includes schematic examples showing how to connect the 82C481 chip. The schematics are broken down into three main groups for discussion:

1) System Bus Interface

82C481 PC/AT (ISA) Bus Circuit Example:

Interfacing the 82C481 to the PC Bus requires buffering of the data bus (74LS245) and optional connection of an EPROM/ROM. All other connections between the PC Bus and the 82C481 are direct and do not require any additional components. If a 32K ROM is used and paging into an 8K address space is desired, then the Monitor ID bits must be driven onto pins MS2:0 by a 74LS244 or 74LS125.

82C481 Unlatched ISA Bus Circuit Example:

Interfacing the 82C481 to the PC Bus requires buffering of the data bus (74LS245) and optional connection of an EPROM/ROM. All other connections between the PC Bus and the 82C481 are direct and do not require any additional components. If a 32K ROM is used and paging into an 8K address space is desired, then the Monitor ID bits must be driven onto pins MS2:0 by a 74LS244 or 74LS125.

82C481 Micro Channel Bus Circuit Example:

Interfacing the 82C481 to the Micro Channel Bus requires buffering of the data bus (74LS245) and optional connection of an EPROM/ROM. If a ROM is used, the ROM addresses need to be latched using 74LS373 octal latches or equivalent. All other connections between the PC Bus and the 82C481 are direct and do not require any additional components. If a 32K ROM is used and paging into an 8K address space is desired, then the Monitor ID bits must be driven onto pins MS2:0 by a 74LS244 or 74LS125.

2) Display Memory Interface

82C481 Memory Configuration A:

This is one of the memory configurations which is commonly implemented for

support of lower resolutions (1280x1024 or below). It is backwards compatible with the 82C480 design. New designs will add nibble mode support (below) unless they use 256K x 8 VRAMs.

In this configuration, the memory banks are interleaved horizontally and share the same 32/40 bit serial data path.

82C481 Memory Configuration A with nibble mode support:

This is the memory configuration which is most commonly implemented for the lower resolutions supported by the 82C481 (1280x1024 or below). In this configuration, the memory bus is 32 bits wide. It must be noted that the WE routing shown here is for the 4bpp mode implemented by the Bt484 RAMDAC. It is not a standard and most other designs will route the WE3A:0A/ and WE3:0/ lines swapped (WE0A/ ←→ WE0/ etc.).

82C481 Memory Configuration B:

This memory configuration is used in high resolution and / or high color implementations. It allows the highest possible serial data output (64/80 bits per serial clock). This memory configuration is not compatible with the 82B484 support chip.

3) Video Interface

82C481 Video Interface Using an InMOS MSG176/178 Color RAMDAC:

The MSG176 is used on the IBM VGA and 8514/A adapter card. It has a triple 6-bit DAC output and requires a current reference. An MSG178 may be used to obtain the extended color definition offered by a triple 8-bit DAC output. An LM339 is required for Monitor Sense. Applications implementing 5-pixel nuggets must use a 74F374 to multiplex the 82C481 and VGA video data paths.

82C481 Video Interface Using a Brooktree Bt471/478 Color RAMDAC:

The Bt471/478 are similar in function to the MSG176/178. The Bt471/478 are



T-52-33-45

shown using a voltage reference (44-pin PLCC). An LM339 is required for Monitor Sense unless Bt475/477 RAMDACs are used. These RAMDACs implement the voltage comparators internally eliminating the need for the LM339. Applications implementing 5-pixel nuggets must use a 74F374 to multiplex the 82C481 and VGA video data paths.

82C481 Video Interface Using a Brooktree Bt484/485 Color RAMDAC:

The Bt484/485 is a high performance RAMDAC which has a VGA compatible register interface. It supports high color modes (24bpp) as well as high resolution non-interlaced displays (up to 135MHz). It also has a hardware cursor which is complementary to the 82C481. Serial clock timing must be generated discretely for this type of implementation but can be done (SCLKs and SOEs) using a few standard TTL devices. (Refer to Application note titled "82C481 Interface to a Bt484/Bt485 RAMDAC").

4) 64200 Wingine Interface

82C481 Interface to CHIPS 64200 "Wingine" VGA.

The 64200 is designed to share its VGA video memory with the 82C481. It also replaces the 82B484 support chip for 1M designs. The 64200 generates all of the necessary VRAM control signals and multiplexes the 32 bit serial data path to an 8-bit Bt47x compatible RAMDAC. This implementation is useful for designs competing in the high volume VGA compatible accelerator market.

82C481 / Wingine PCB

The form factor necessary to implement a Wingine + 82C481 design is a small 6.2" x 4.2" form factor.

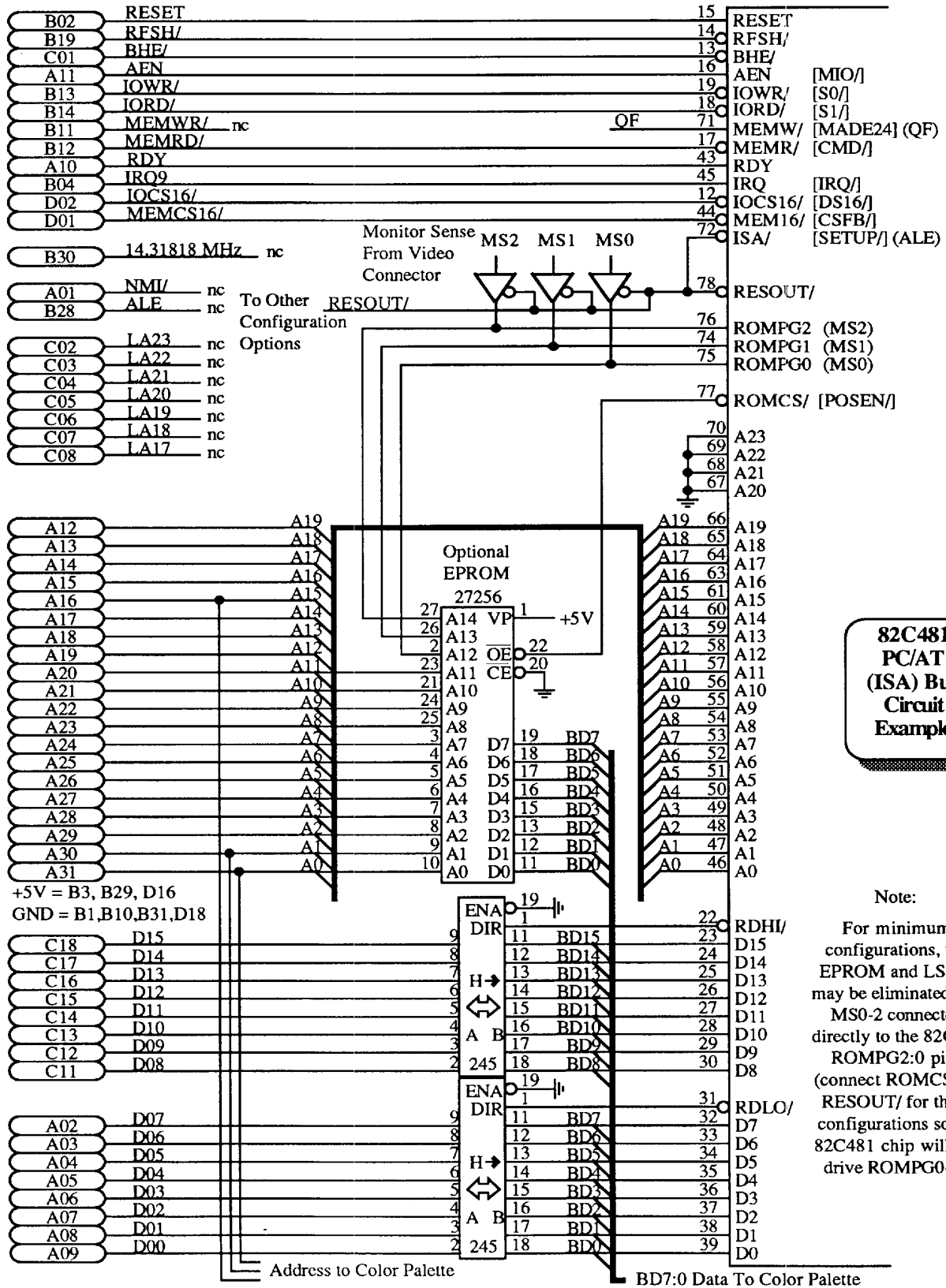



Application Schematic Examples

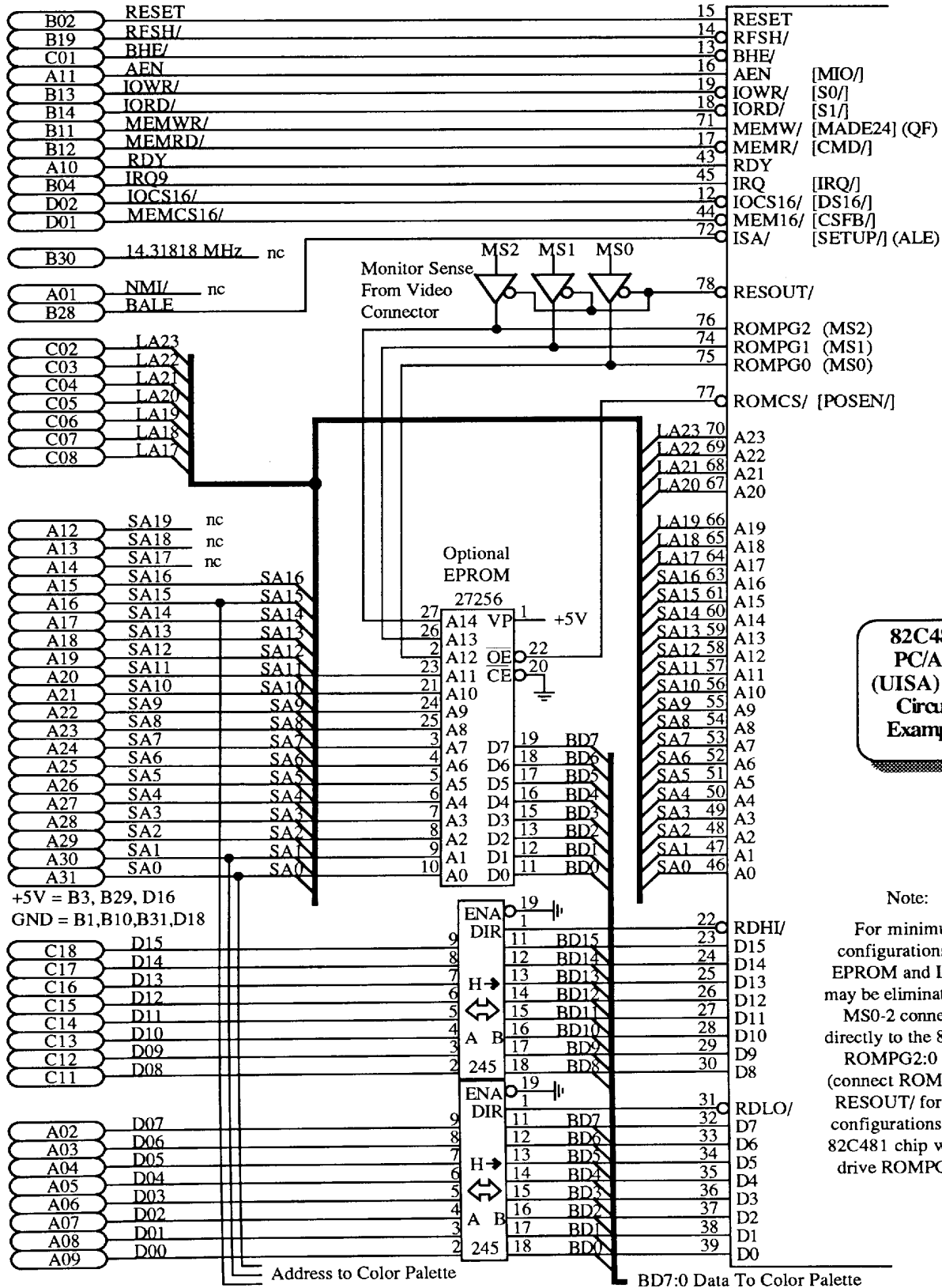

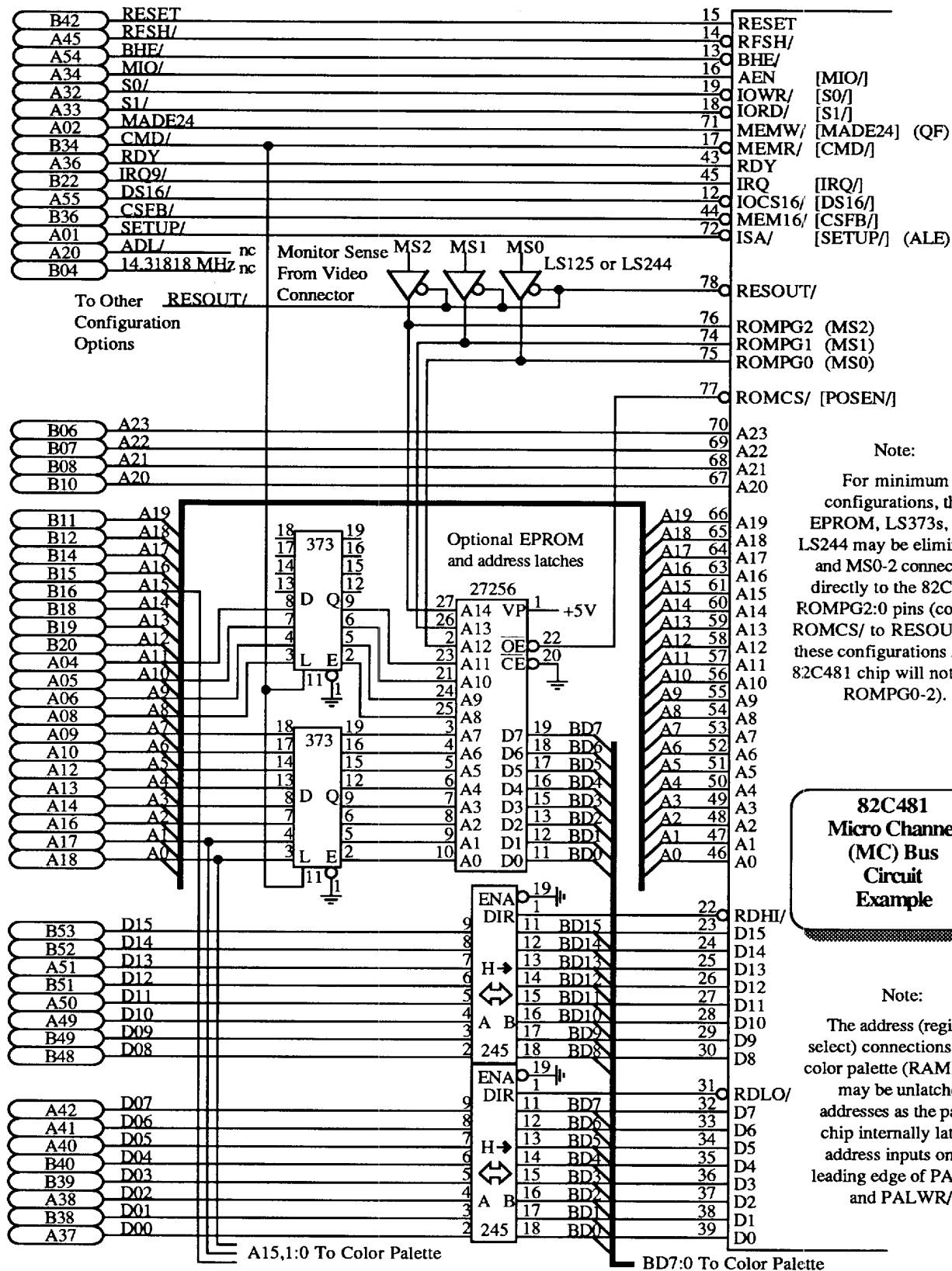



Application Schematic Examples

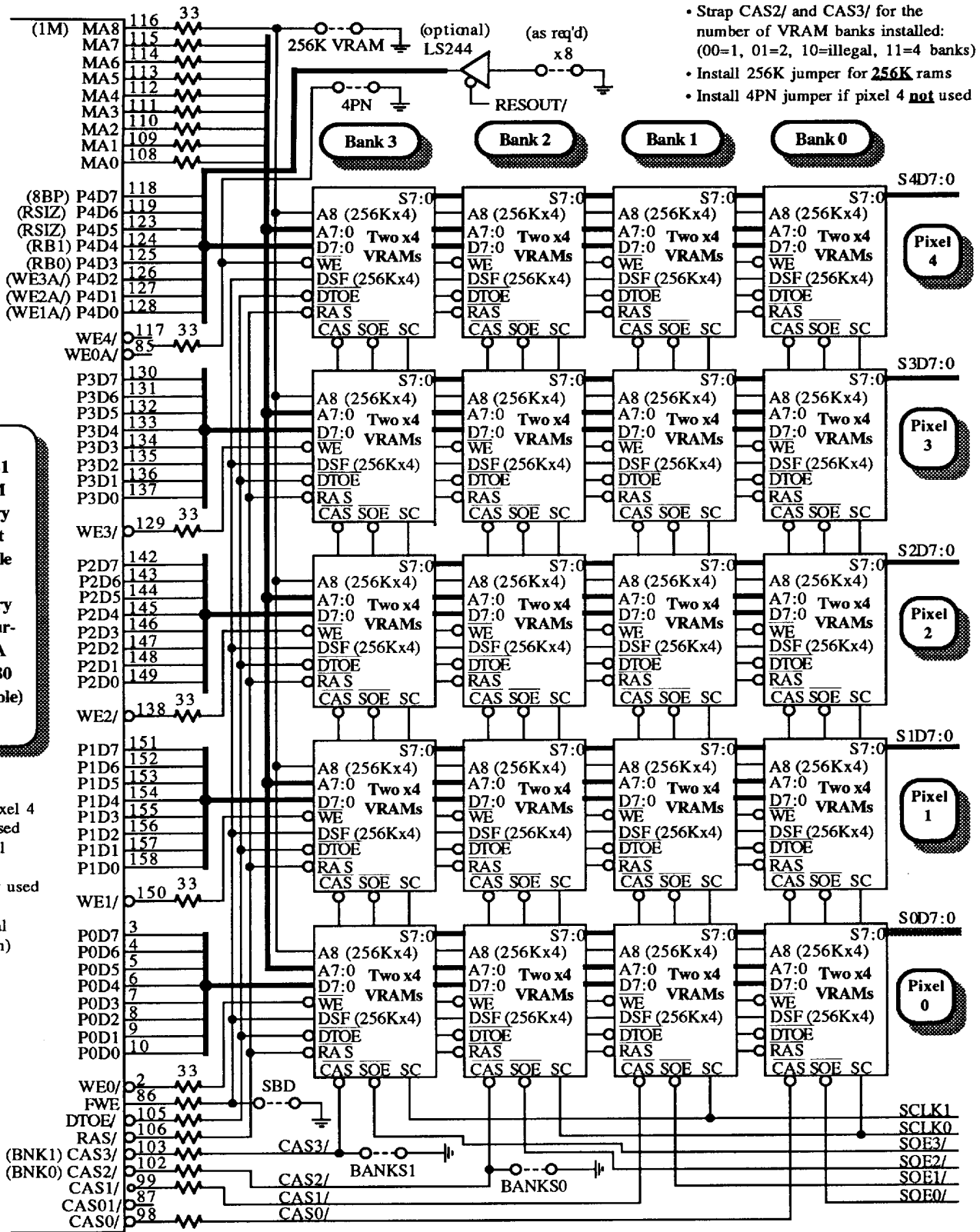

82C481 VRAM Memory Circuit Example - Memory Configuration A (82C480 compatible)

Note: Pixel 4 is only used in 5-pixel systems (normally used for 1280 horizontal resolution)



Warning: The WE line connections match the pixel shift order used by the Bt484 in 4bpp mode. These connections may be different for other color palette designs.

**82C481
VRAM
Memory
Circuit
Example
-
Memory
Configuration
A
(Nibble
Mode)**

Note: Pixel 4 is not used in Nibble Mode systems. This circuit will support 2048 x 1024 x 4 from bank 0 (1M). To enable the alternate WE3A:0A signals, FRAME must be pulled low during reset.

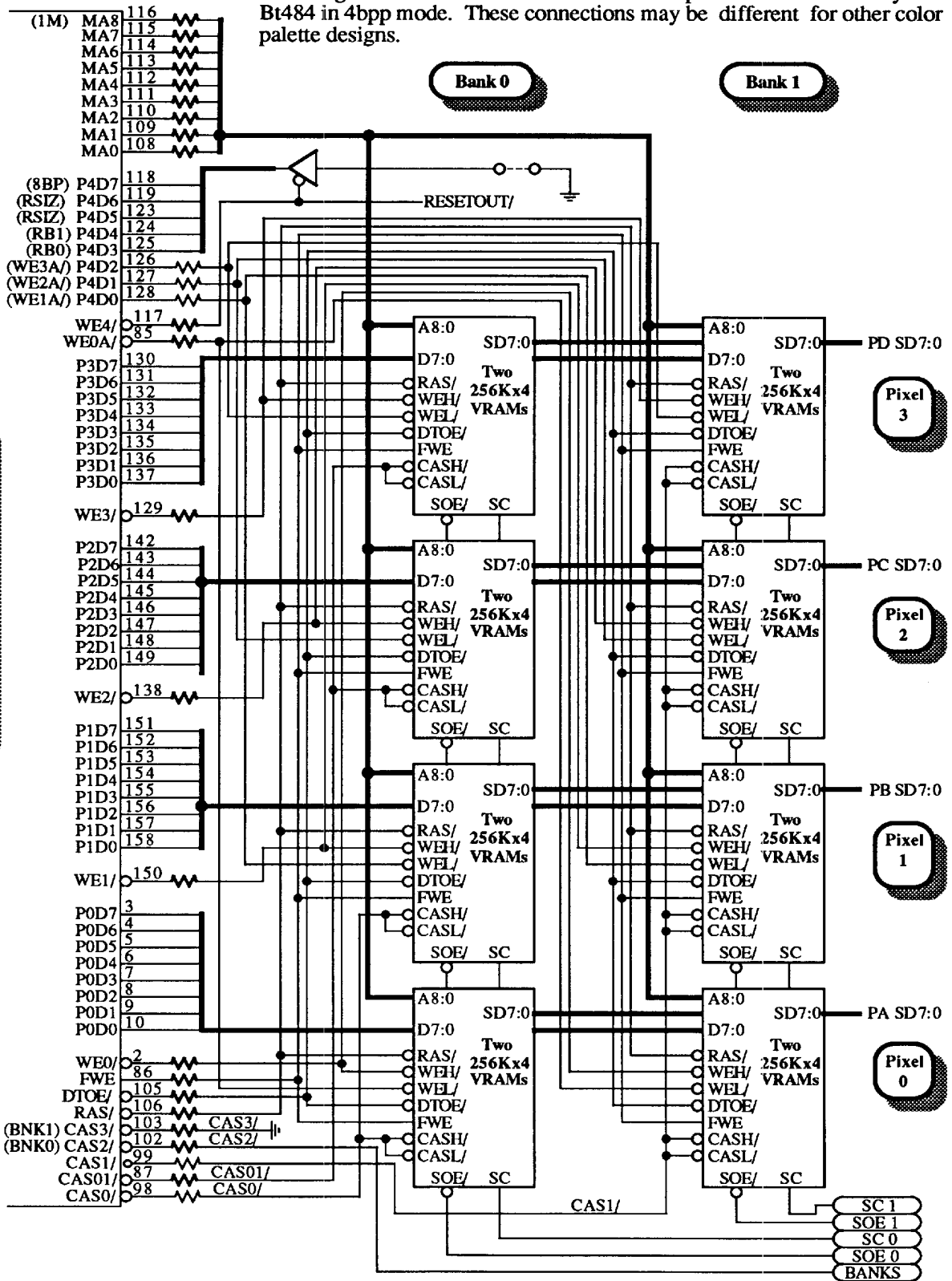



Application Schematic Examples

- Strap CAS2/ and CAS3/ for the number of VRAM banks installed: (00=n/a, 01=2, 10=3, 11=4 banks)
- Install 1MVRAM jumper for 256K rams
- Install 4PN jumper if pixel 4 not used

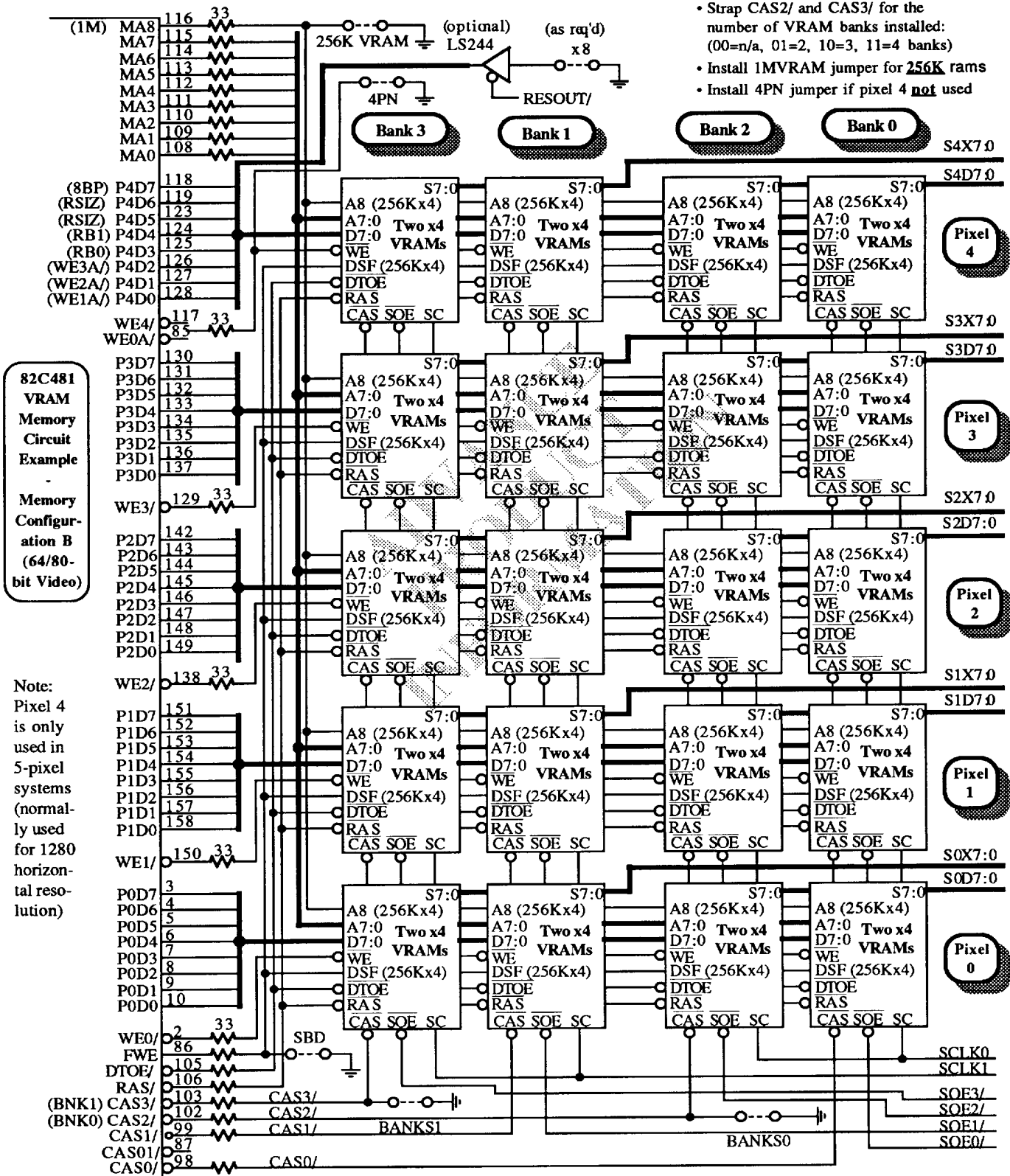

82C481 VRAM Memory Circuit Example
Memory Configuration B (64/80-bit Video)

Note: Pixel 4 is only used in 5-pixel systems (normally used for 1280 horizontal resolution)

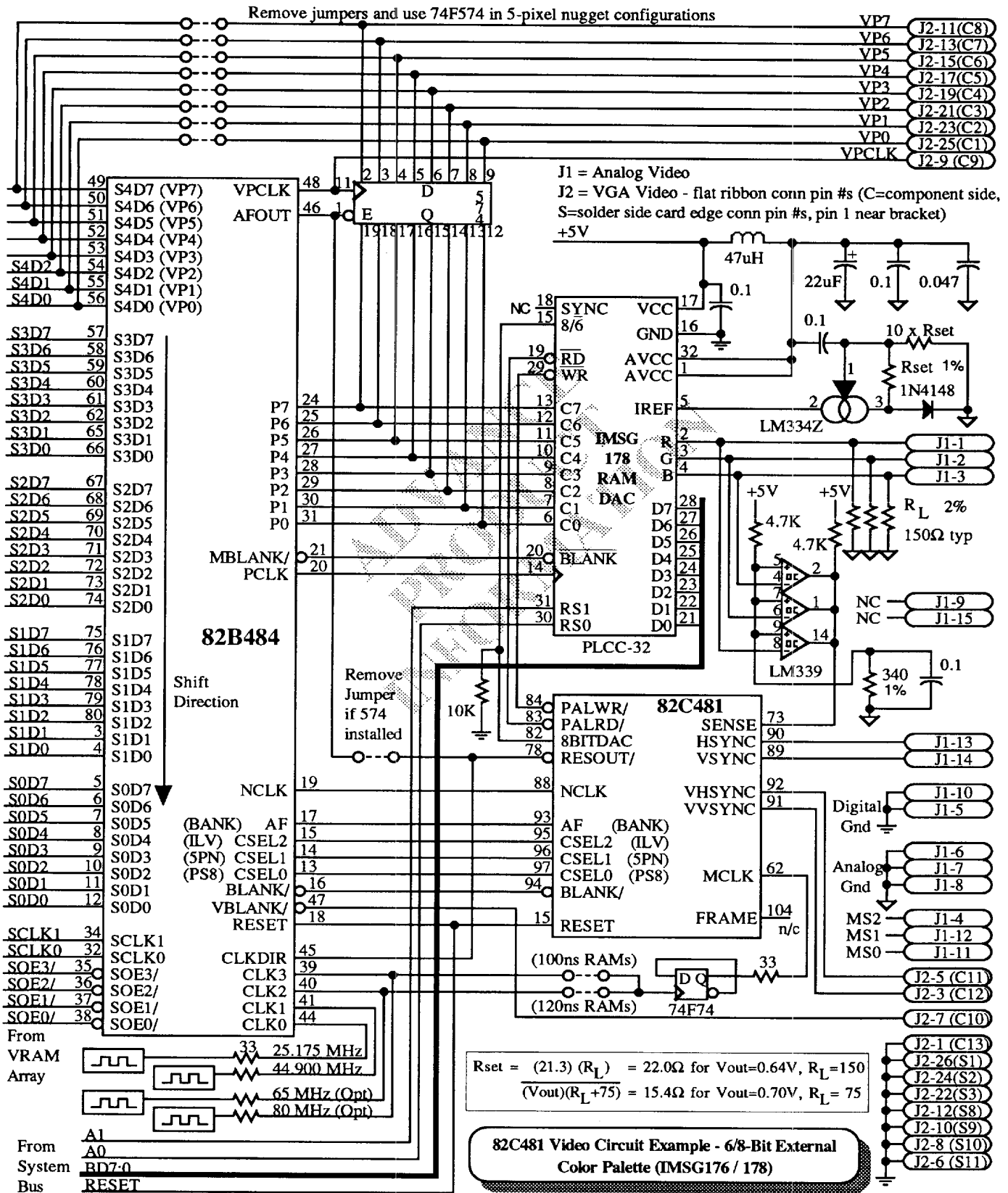

Revision 0.3

107

Advance Product Information 82C481

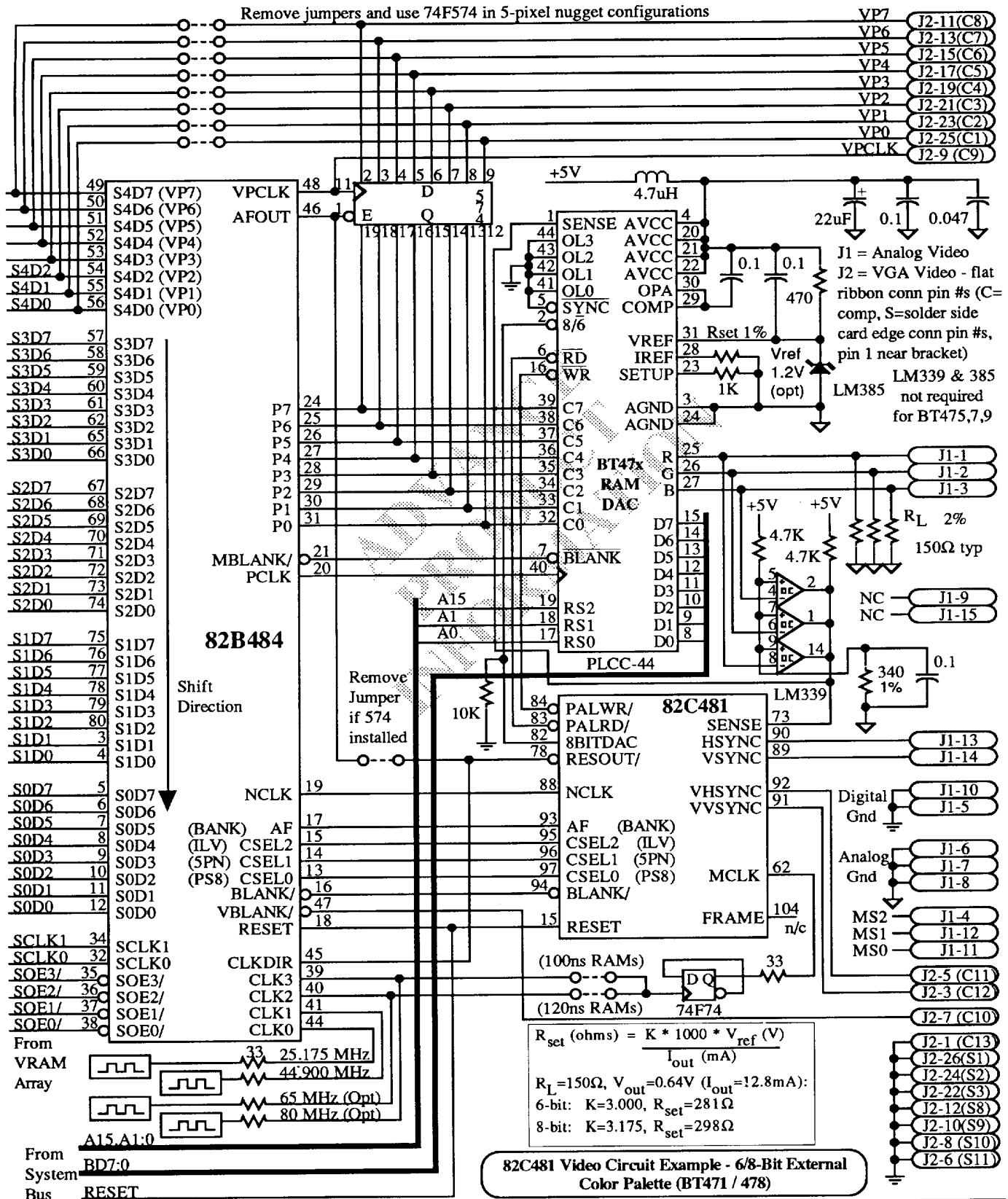

82C481 Video Circuit Example - 6/8-Bit External Color Palette (BT471 / 478)

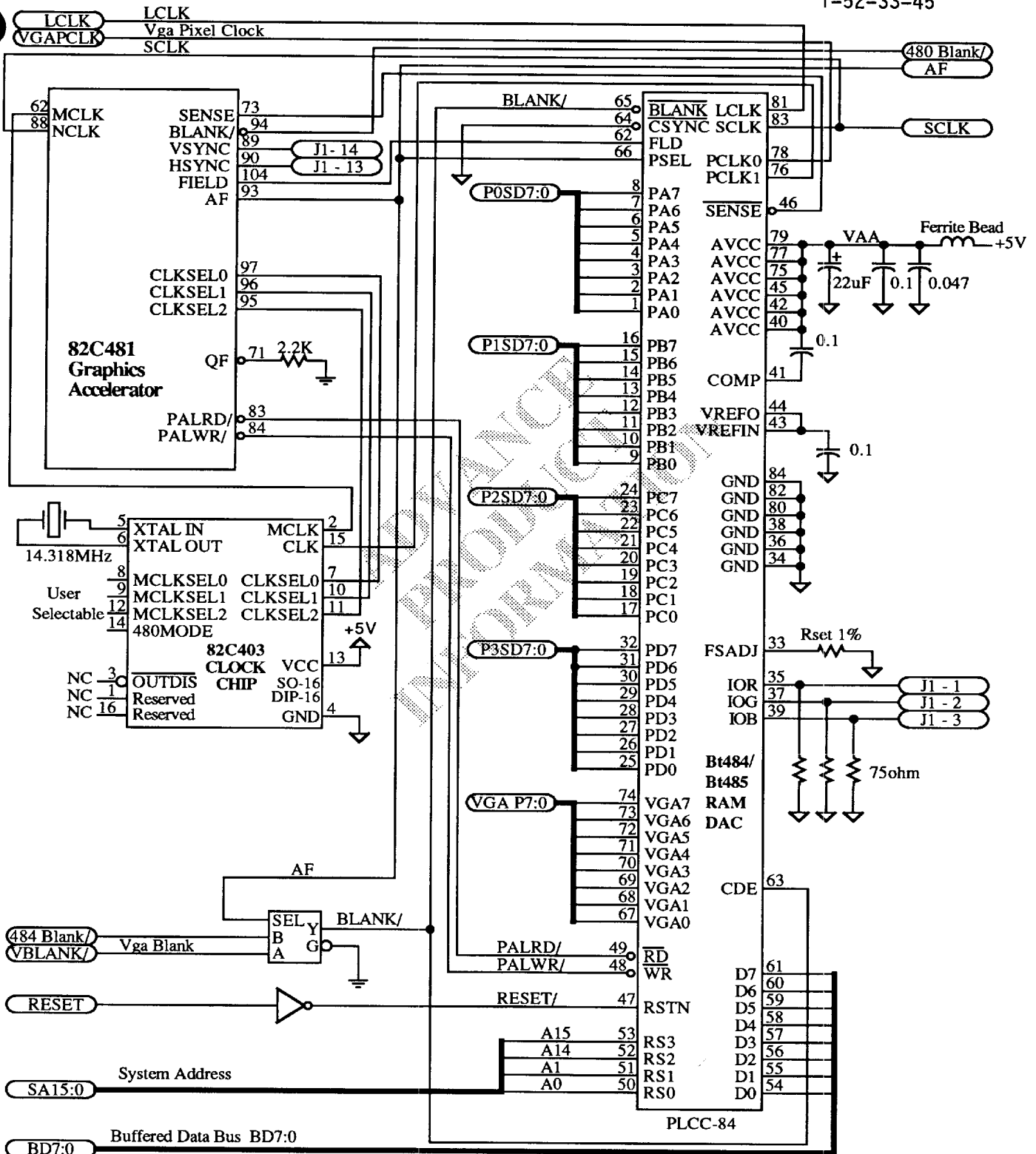

82C481 Video Circuit Example - High Performance RAMDAC (BT484 / 485)



T-52-33-45

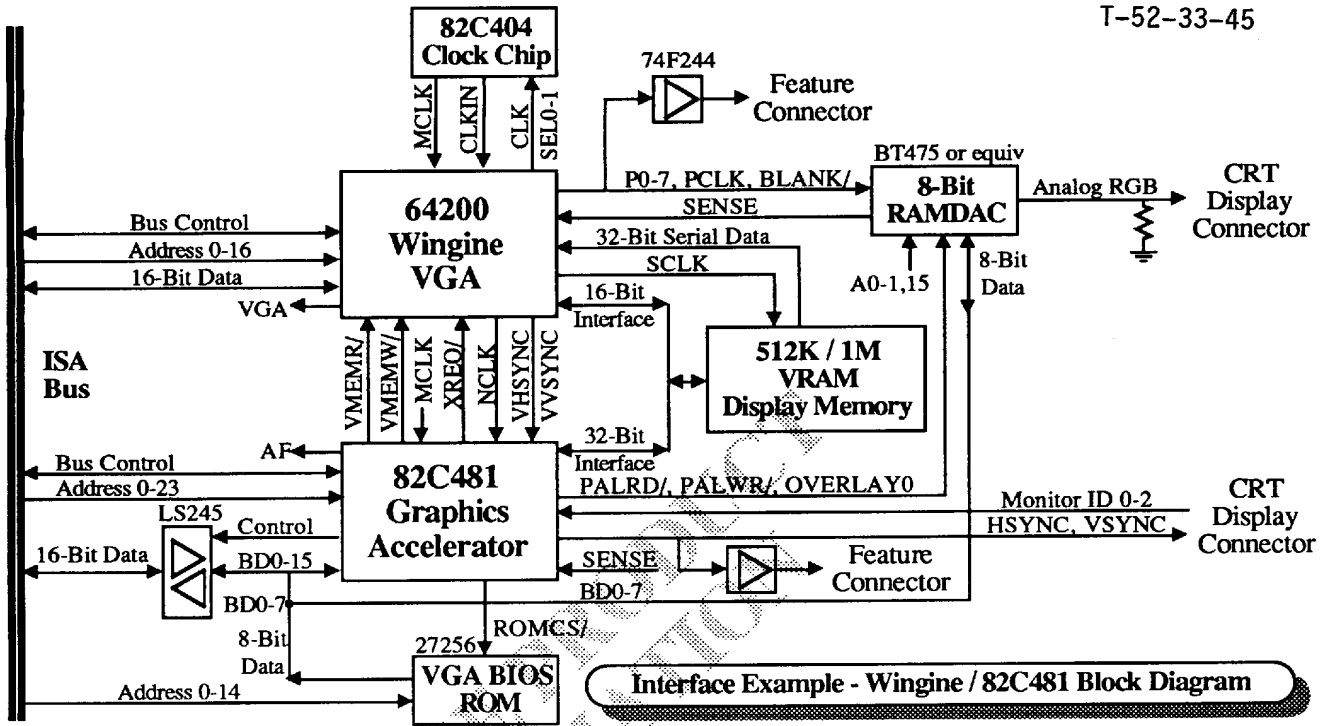

Interface Example - Wingine / 82C481 Block Diagram

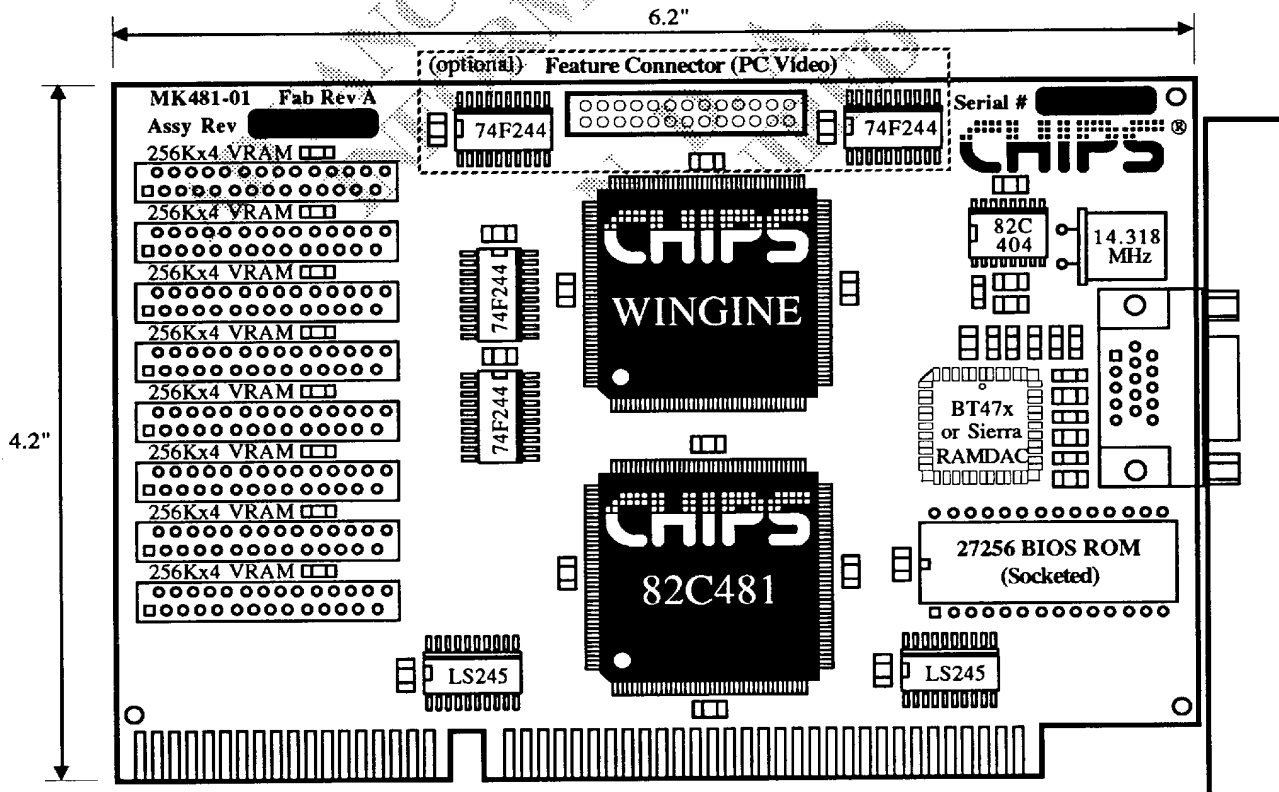

Example Wingine / 82C481 PCB

Electrical Specifications

ABSOLUTE MAXIMUM CONDITIONS

Symbol	Parameter	Min	Max	Units
P_D	Power Dissipation	–	1.0	W
V_{CC}	Supply Voltage	–0.5	6.5	V
V_I	Input Voltage	–0.5	$V_{CC}+0.5$	V
V_O	Output Voltage	–0.5	$V_{CC}+0.5$	V
T_{OP}	Operating Temperature (Ambient)	–25	85	°C
T_{STG}	Storage Temperature	–40	125	°C

Note: Permanent device damage may occur if Absolute Maximum Ratings are exceeded. Functional operation should be restricted to the conditions described under Normal Operating Conditions.

NORMAL OPERATING CONDITIONS

Symbol	Parameter	Min	Typ	Max	Units
V_{CC}	Supply Voltage	4.5	5	5.5	V
T_A	Ambient Temperature	0	–	70	°C

DC CHARACTERISTICS

(Under Normal Operating Conditions Unless Noted Otherwise)

Symbol	Parameter	Notes	Min	Max	Units
I_{CC1}	Power Supply Current	@50 MHz MCLK, 0°C	–	190	mA
I_{IL}	Input Leakage Current	Input, Tristate and Bidirectional Pins	–	10	µA
		@ $V_{IL} = -0.5V$ for pins with internal pullups	–	300	µA
I_{OZ}	Output Leakage Current	High Impedance	–100	+100	µA
V_{IL}	Input Low Voltage		–0.5	0.8	V
V_{IH}	Input High Voltage		2.0	$V_{CC}+0.5$	V
V_{OL}	Output Low Voltage	$I_{OL} = -12$ mA (IRQ, HSYNC, VSYNC)	–	0.4	V
		$I_{OL} = -6$ mA (all others)	–	0.4	V
V_{OH}	Output High Voltage	$I_{OH} = 8$ mA (IRQ)	2.4	–	V
		$I_{OH} = 0.5$ mA (all others)	2.4	–	V

Electrical specifications contained herein are preliminary and subject to change without notice.



T-52-33-45

AC TIMING CHARACTERISTICS - NUGGET CLOCK TIMING

Symbol	Parameter	Notes	Min	Max	Units
T _{NCLK}	Nugget Clock Cycle Time	Note 1	22	-	nS
T _{OCLK}	Octet Clock Cycle Time	T _{NCLK} *(EC1[13:11]+1)	30	-	nS
T _{NCLKH}	Nugget Clock High Time		11	-	nS
T _{NCLKL}	Nugget Clock Low Time		11	-	nS
T _{BLV}	Nugget CLK to Blank, Alternate Blank Valid		-	18	nS
T _{AFCV}	Nugget Clock to AF, CSEL valid		-	18	nS
T _{BLHLD}	Blank, Alternate Blank hold from NCLK		2	-	nS
T _{AFCHLD}	AF, CSEL Hold from NCLK High		2	-	nS

Note 1: The Nugget Clock frequency must be high enough to satisfy the refresh requirements of the VRAMs. The limiting display mode will be the one for which the horizontal total value is greatest. Refresh is performed for two VRAM rows each horizontal scan line. Therefore, for 1M VRAMs, the Refresh Period = T_{NCLK}*(horizontal total)*256. The internal octet clock (post divided NCLK) must not exceed 32MHz.

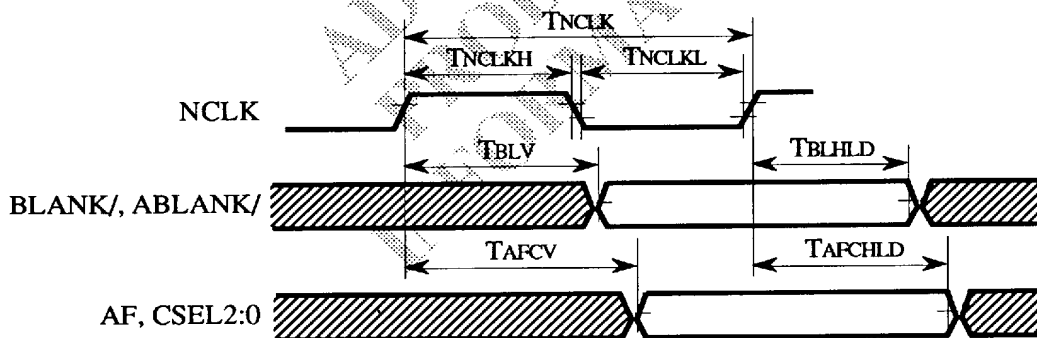

82C481 Nugget Clock Timing

AC TIMING CHARACTERISTICS - RESET TIMING

Symbol	Parameter	Notes	Min	Max	Units
-	RESET Pulse Width		64 T _{MCLK}	-	nS
T _{MCLK}	Memory Clock period	Dependant on VRAM access time	20	-	nS
T _{MCLKH}	Memory Clock High		9	-	nS
T _{MCLKL}	Memory Clock Low		9	-	nS

Output load C_L = 50pF unless otherwise noted.



T-52-33-45

AC TIMING CHARACTERISTICS - ISA BUS TIMING

Symbol	Parameter	Notes	Min	Max	Units
T1	IORD/, IOWR/ Pulse Width	Video registers	$3 \cdot T_{OCLK}$	–	nS
		All others	$4 \cdot T_{MCLK}$	–	nS
T2	RDY tristate (high-z) from IORD/, IOWR/ inactive	Note 2	–	25	nS
T3	A19:0, RFSH/, AEN setup to command		40	–	nS
T4	A19:0, RFSH/, AEN hold from command		20	–	nS
T6	I/O Read Data valid from IORD/ active		–	50	nS
T7	I/O Read Data hold from IORD/ inactive		0	40	nS
T8	IOWR/ active to Data in Valid		–	15	nS
T9	I/O Write Data hold from IOWR/ inactive		0	–	nS
T12	IORD/, IOWR/ to RDY inactive (Low)	Note 3	–	25	nS
T16	ROMCS/, PALRD/ active from MEMR/, IORD/		0	45	nS
T17	RDLO/, RDHI/ active from MEMR/, IORD/		–	45	nS
T18	RDLO/, RDHI/ inactive from MEMR/, IORD/		–	45	nS
T19	ROMCS/, PALRD/ inactive from MEMR/, IORD/	Note 3	0	25	nS
T20	IOCS16/ active from Address Valid		–	25	nS
T21	IOCS16/ inactive from Address Valid		–	25	nS
T22	PALWR/ active from IOWR/		–	25	nS
T23	PALWR/ inactive from IOWR/		–	25	nS
T25	IORD/, IOWR/ recovery time		80	–	nS
T26	BHE/ valid to IORD/, IOWR/ active		25	–	nS
T27	BHE/ hold from IORD/, IOWR/ inactive		30	–	nS
T28	ROMPG[2:0] valid from MEMR/ active		–	25	nS
T29	ROMPG[2:0] hold from MEMR/ inactive		0	–	nS
T80	LA23:17 hold from ALE inactive low		10	–	nS
T81	LA23:17 valid setup to ALE active high		0	–	nS
T82	MEM CS 16/ Active from LA23:17 Valid		0	30	nS
T83	MEM CS 16/ Inactive from LA23:17 Invalid		0	30	nS
T84	ALE high pulse width		30	–	nS
T85	MEMR/, MEMW/ active to OWS/ active		0	15	nS
T86	MEMR/, MEMW/ inactive to OWS/ inactive		0	30	nS
T87	VMEMR/, VMEMW/ active from MEMR/, MEMW/		0	15	nS
T88	VMEMR/, VMEMW/ inactive from MEMR/, MEMW/		0	15	nS

Note 2: The 82C481 will asynchronously bring RDY active (high-z) if the current command cycle ends while ready is inactive (low).

Note 3: The 82C481 does not exert RDY low for accesses to the palette at VGA I/O addresses (03C6h-03C9h).

Output load $C_L = 50\text{pF}$ unless otherwise noted.



T-52-33-45

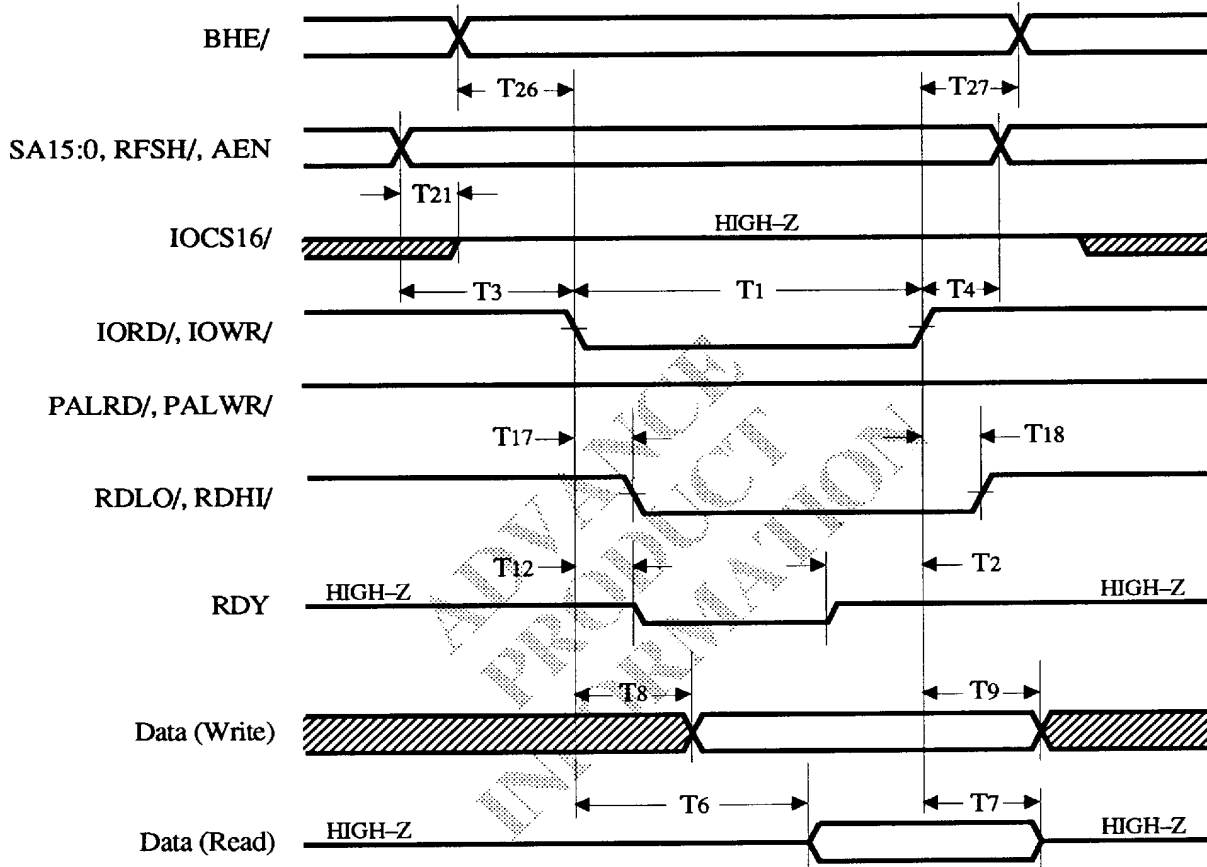

ISA-UISA 8-Bit Bus I/O Cycle Timing

Note: LA23:17, SA16, and ALE are not used in I/O access decodes. OWS/ is only returned during valid memory accesses.

T-52-33-45

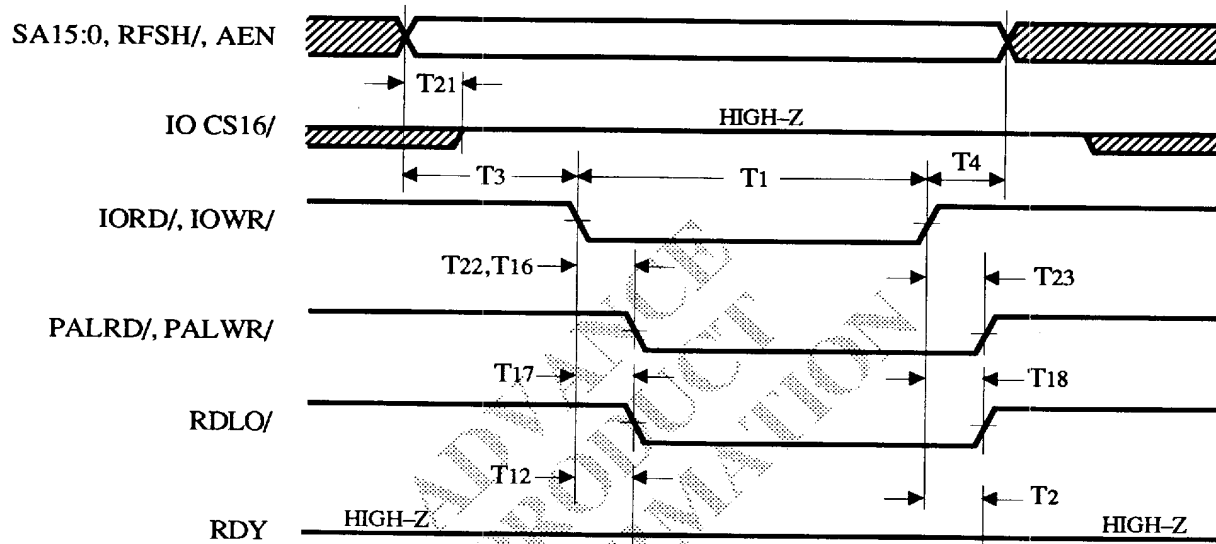

ISA-UISA Bus Palette I/O Cycle Timing

Note: LA23:17, SA16, and ALE are not used in I/O access decodes. OWS/ is only returned during valid memory accesses.

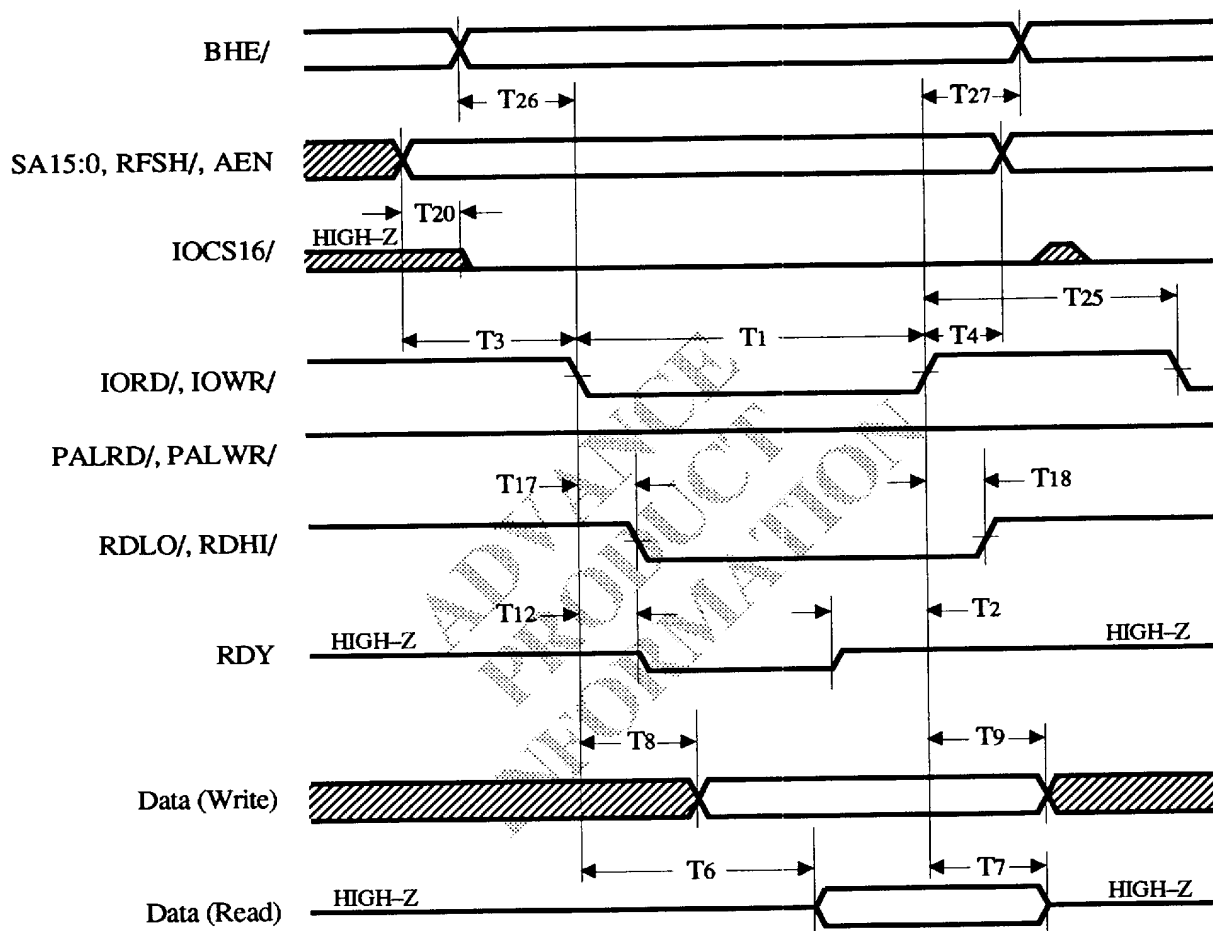

ISA-UISA Bus 16-Bit I/O Cycle Timing

Note: LA23:17, SA16, and ALE are not used in I/O access decodes. OWS/ is only returned during valid memory accesses.

T-52-33-45

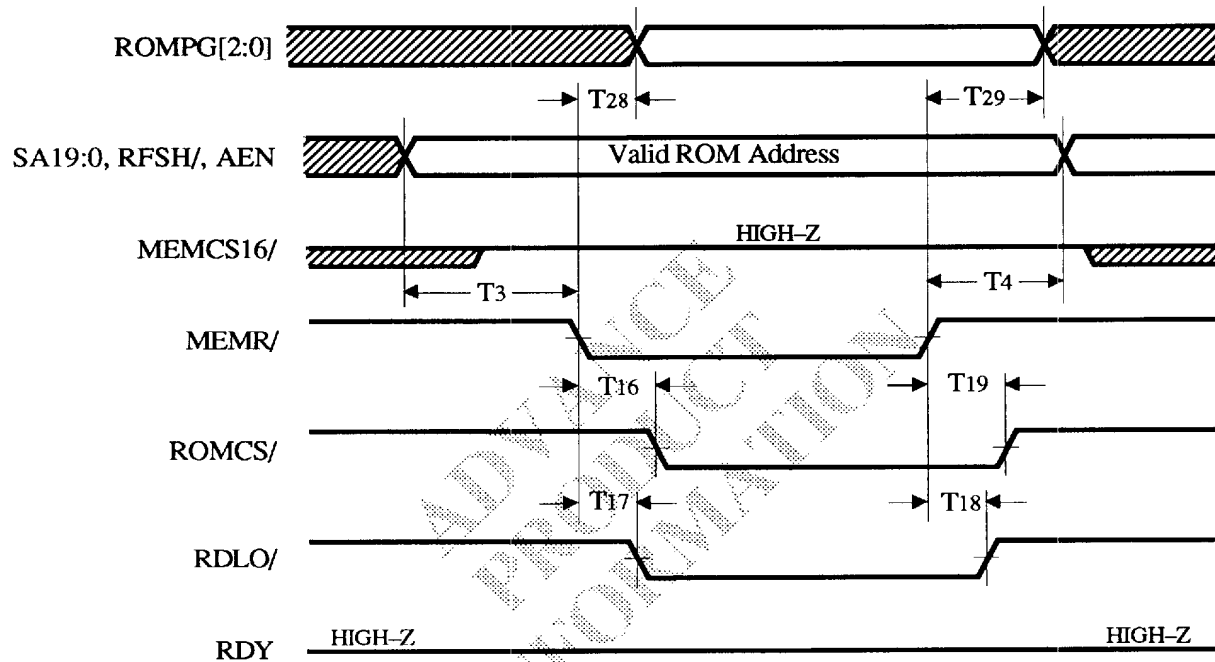

ISA Bus ROM Memory Cycle Timing



T-52-33-45

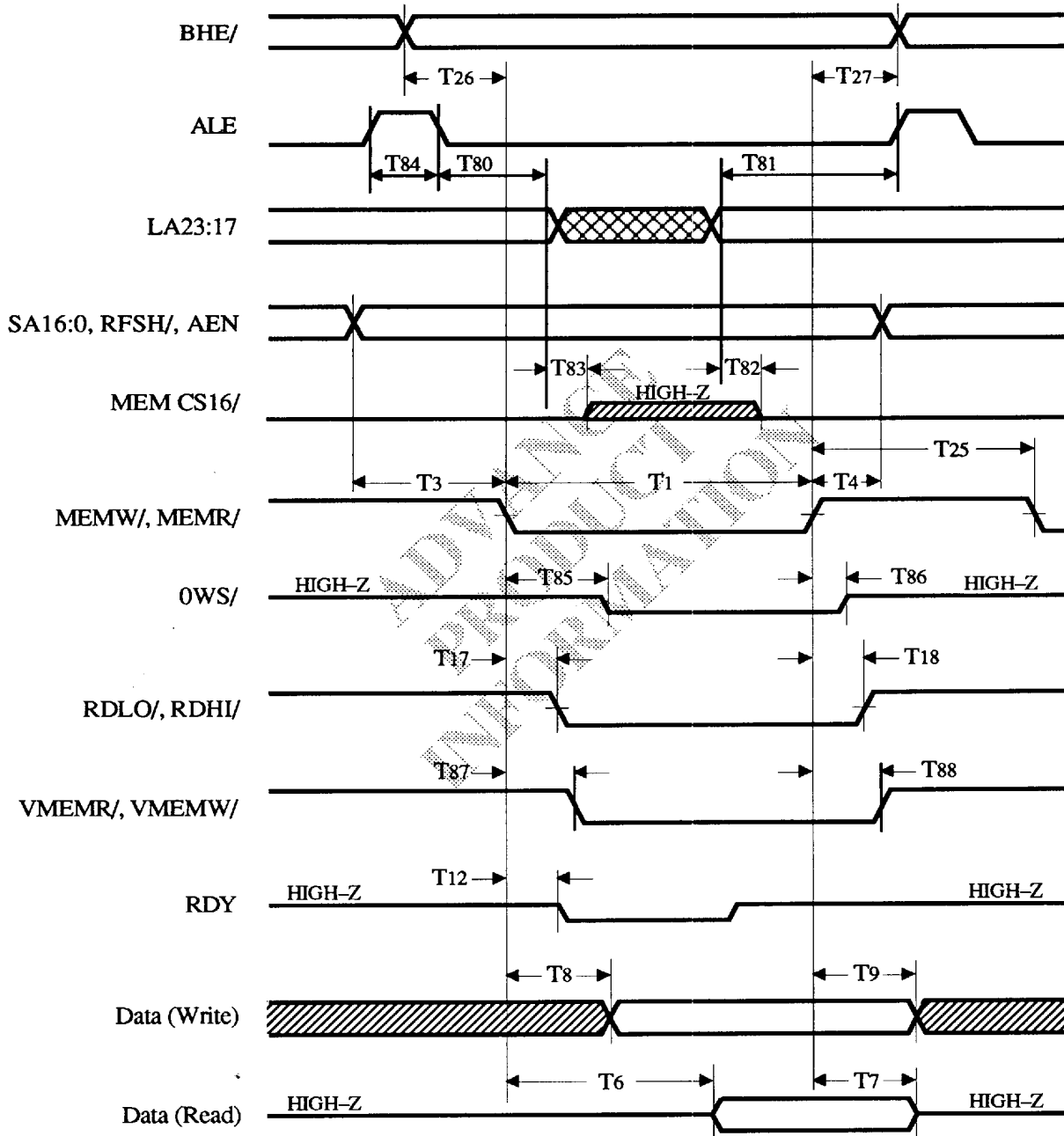

UISA Bus 16-Bit Memory Cycle Timing



T-52-33-45

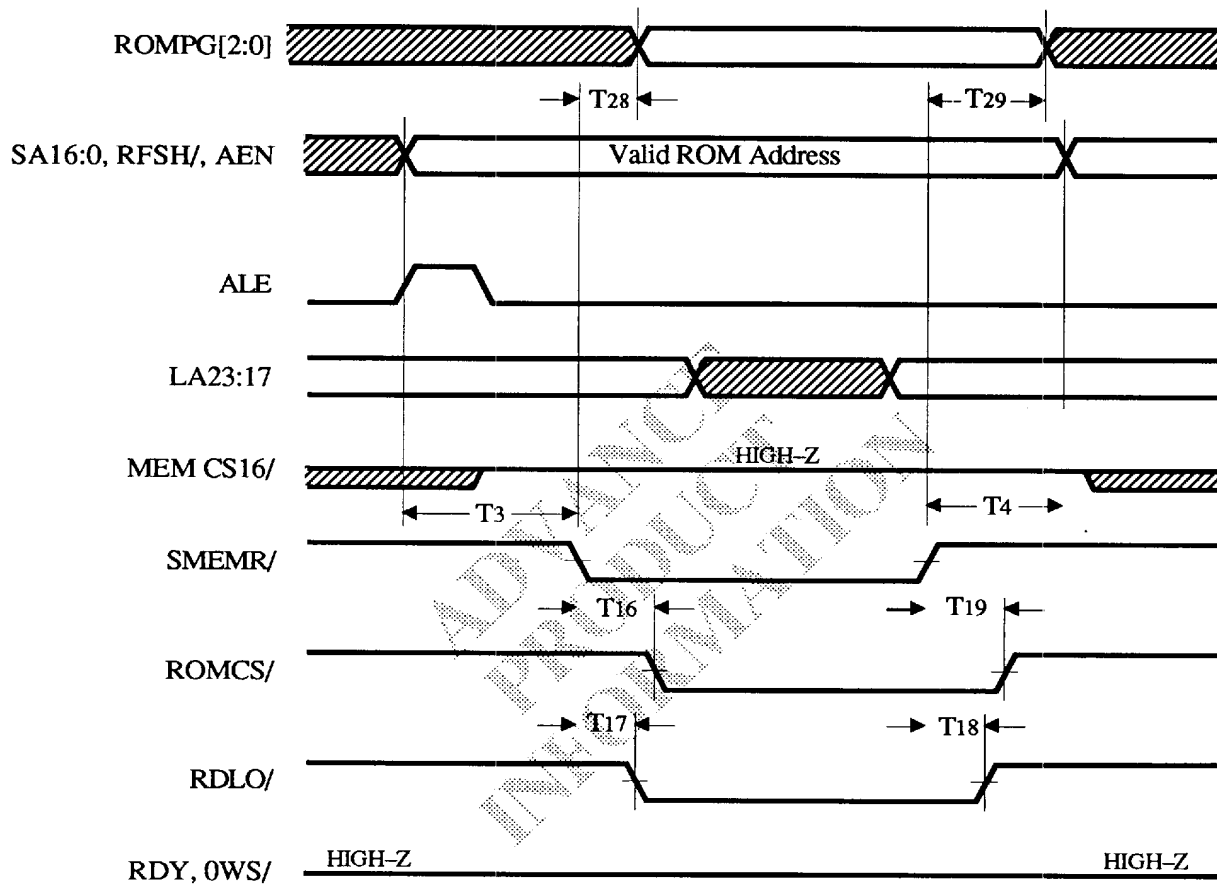

UISA Bus ROM Memory Cycle Timing



T-52-33-45

AC TIMING CHARACTERISTICS - MICRO CHANNEL BUS TIMING

Symbol	Parameter	Notes	Min	Max	Units
T40	Status hold from CMD/ inactive		20	-	nS
T42	Address hold from CMD/ inactive		30	-	nS
T43	Status setup to CMD/ active		45	-	nS
T44	Address Valid setup to CMD/ active		55	-	nS
T45	CMD/ Pulse Width	Video registers	$3 \cdot T_{OCLK}$	-	nS
		All others	$4 \cdot T_{MCLK}$	-	nS
T46	CMD/ inactive to next CMD/ active		80	-	nS
T47	CMD/ active to Write Data Valid		-	15	nS
T48	Write data hold from CMD/ inactive		0	-	nS
T49	Read data valid from CMD/ active		-	50	nS
T50	Read data hold from CMD/ inactive		0	40	nS
T52	CSFB/ active from Address valid		-	25	nS
T53	RDY active from CMD/ active		-	$256 \cdot T_{MCLK}$	nS
T54	Read data valid from RDY active (high)		-	50	nS
T55	RDY inactive (low) from Address valid		-	25	nS
T56	PALWR/ delay from CMD/ active		-	25	nS
T57	ROMCS/, PALRD/ active from CMD/ active		-	45	nS
T60	CSFB/ inactive from Address invalid		-	25	nS
T61	PALWR/ inactive from CMD/ inactive		-	25	nS
T62	BHE/ valid to CMD/ active		25	-	nS
T63	BHE/ hold from CMD/ active		30	-	nS
T64	ROMCS/, PALRD/ inactive from CMD/ inactive		-	25	nS
T65	DS16/ active from Address valid		-	25	nS
T66	DS16/ inactive from Address invalid		-	25	nS
T67	POSEN/ active from CMD/ active		-	45	nS
T68	POSEN/ inactive from CMD/ inactive		-	25	nS
T69	RDLO/, RDHI/ active from CMD/ active		-	45	nS
T70	RDLO/, RDHI/ inactive from CMD/ inactive		-	45	nS
T71	ROMPG[2:0] valid from CMD/ active		-	25	nS
T72	ROMPG[2:0] hold from CMD/ inactive		0	-	nS

Output load $C_L = 50pF$ unless otherwise noted.

T-52-33-45

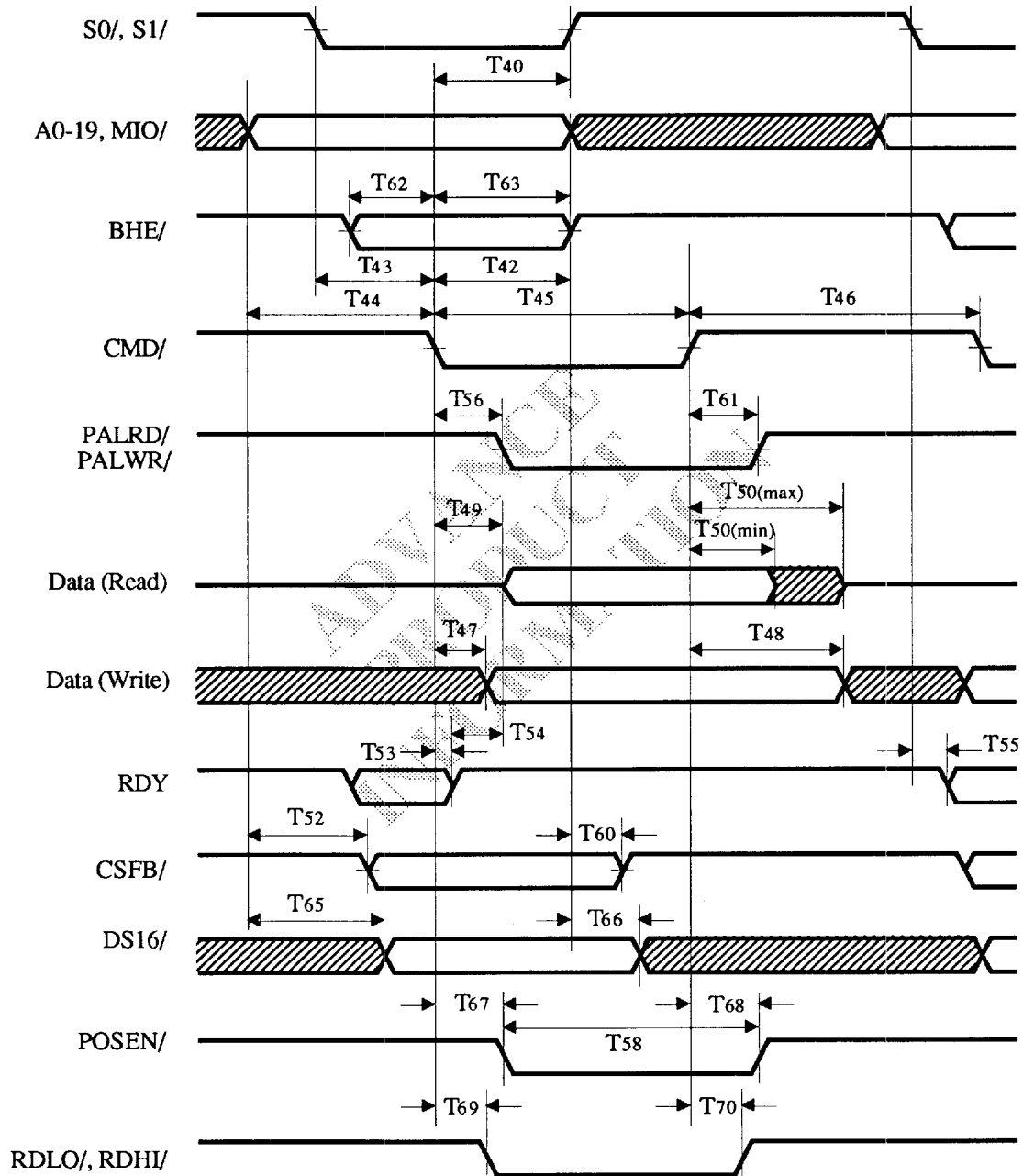

Micro Channel I/O BUS Cycle Timing

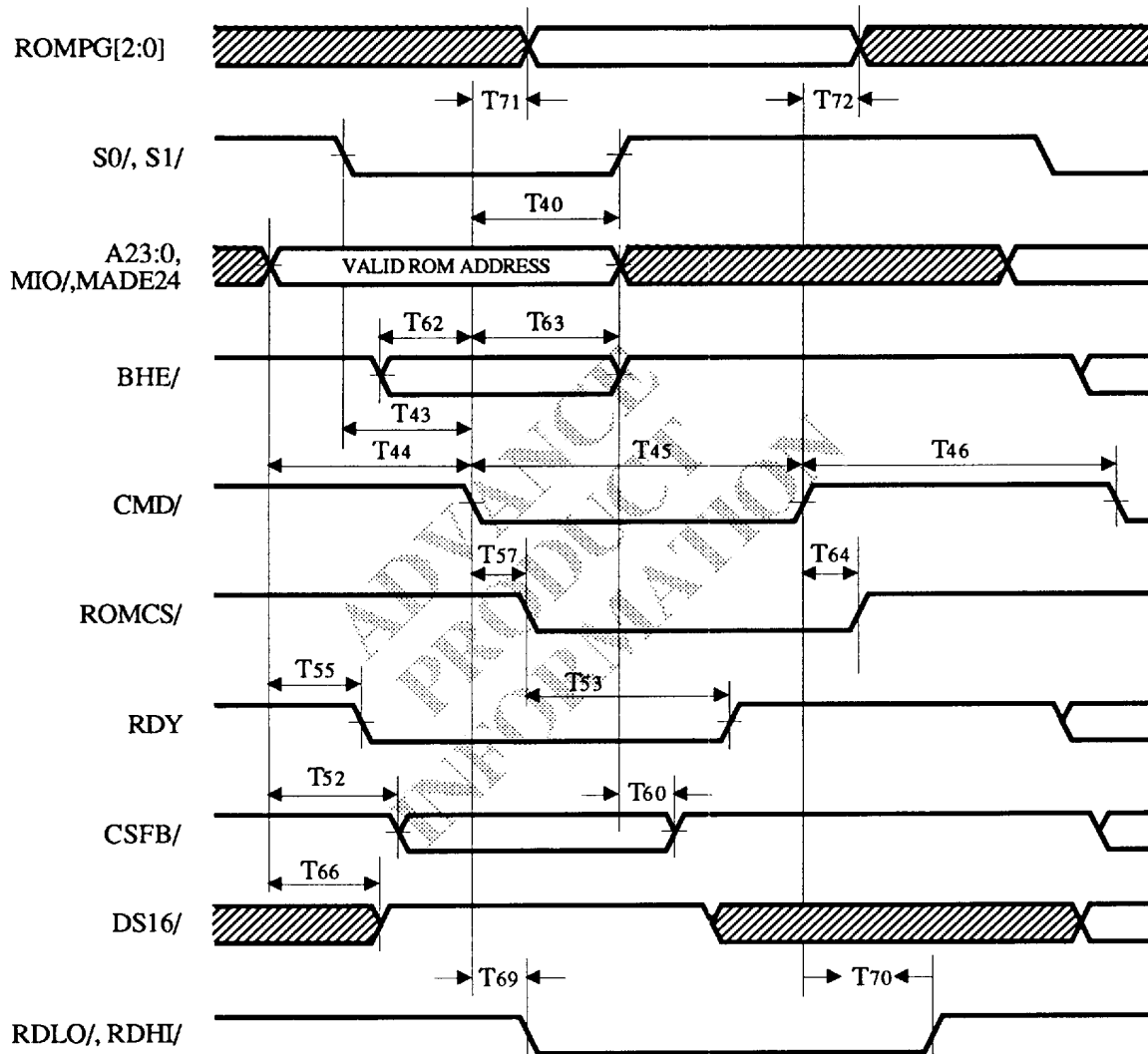

Micro Channel Bus ROM Memory Cycle Timing



AC CHARACTERISTICS

T-52-33-45

VRAM TIMING - SWITCHING CHARACTERISTICS

Symbol	Parameter	Min	Max	Units
T_{RAC}	Data Access Time from RAS/	–	100	nS
T_{CAC}	Data Access Time from CAS/	–	30	nS
T_{AA}	Access time from Column Address	–	60	nS
T_{ACP}	Access time from rising edge of CAS/	–	60	nS
T_{OEA}	Access time from OE/	–	30	nS
T_{OFF}	Output disable time from CAS/ high	–	30	nS
T_{OEZ}	Output disable time from OE/ high	–	30	nS

Note: All VRAM timing characteristics are referenced to a 40 MHz MCLK.

VRAM TIMING - TIMING REQUIREMENTS

Symbol	Parameter	Min	Max	Units
T_{RC}	Random read or write cycle time	200	–	nS
T_{RWC}	Read-modify-write cycle time	300	–	nS
T_{PC}	Fast-page cycle time	75	–	nS
T_{PRWC}	Fast-page read-modify-write cycle time	150	–	nS
T_{RP}	RAS/ precharge	80	–	nS
T_{RAS}	RAS/ pulse width	100	–	nS
T_{RASP}	Fast-page RAS/ pulse width	100	–	nS
T_{RSH}	RAS/ hold from CAS/	35	–	nS
T_{CPN}	CAS/ precharge	15	–	nS
T_{CP}	Fast-page CAS/ precharge time	15	–	nS
T_{CAS}	CAS/ pulse width	50	–	nS
T_{CSH}	CAS/ hold from RAS/	110	–	nS
T_{RCD}	RAS/ to CAS/ delay	50	–	nS
T_{CRP}	CAS/ high to RAS/ low precharge	25	–	nS
T_{ASR}	Row Address setup time	5	–	nS
T_{RAH}	Row Address hold time	15	–	nS
T_{ASC}	Column Address setup to CAS/	10	–	nS
T_{CAH}	Column Address hold time	20	–	nS

Note: Output load $C_L = 50\text{pF}$, unless otherwise noted.



AC CHARACTERISTICS

T-52-33-45

VRAM TIMING - TIMING REQUIREMENTS (continued)

Symbol	Parameter	Min	Max	Units
T _{RAD}	RAS/ to Column Address delay time	25	45	nS
T _{RAL}	Column Address to RAS/ lead time	25	-	nS
T _{RCS}	Read command setup time	10	-	nS
T _{RRH}	Read command hold time after RAS/ high	15	-	nS
T _{RCH}	Read command hold time after CAS/ high	10	-	nS
T _{WCH}	Write command hold time	30	-	nS
T _{WP}	Write command pulse width	40	-	nS
T _{RWL}	Write command to RAS/ lead time	40	-	nS
T _{CWL}	Write command to CAS/ lead time	40	-	nS
T _{DS}	Data-in setup time	10	-	nS
T _{DH}	Data-in hold time	25	-	nS
T _{AWD}	Column Address to WE/ delay	100	-	nS
T _{CWD}	CAS/ to WE/ delay	100	-	nS
T _{RWD}	RAS/ to WE/ delay	150	-	nS
T _{OED}	OE/ high to data-in setup delay	15	-	nS
T _{OEH}	OE/ high hold time after WE/ low	35	-	nS
T _{RPC}	RAS/ high to CAS/ low precharge time	25	-	nS
T _{DLS}	DT/ low setup time	5	-	nS
T _{RDH}	DT/ low hold time after RAS/ low	100	-	nS
T _{CDH}	DT/ low hold time after CAS/ low	40	-	nS
T _{DHS}	DT/ high setup time	25	-	nS
T _{DHH}	DT/ high hold time	25	-	nS
T _{DTR}	DT/ high to RAS/ high delay	10	-	nS
T _{DTC}	DT/ high to CAS/ high delay	10	-	nS
T _{WBS}	Write-per-bit setup time	5	-	nS
T _{WBH}	Write-per-bit hold time	25	-	nS
T _{WS}	Write bit selection setup time	3	-	nS
T _{WH}	Write bit selection hold time	25	-	nS
T _{DTH}	DT/ high hold time after RAS/ high	25	-	nS
T _{FWS}	FWE setup to RAS/ low	5	-	nS
T _{FWH}	FWE hold from RAS/ low	25	-	nS



T-52-33-45

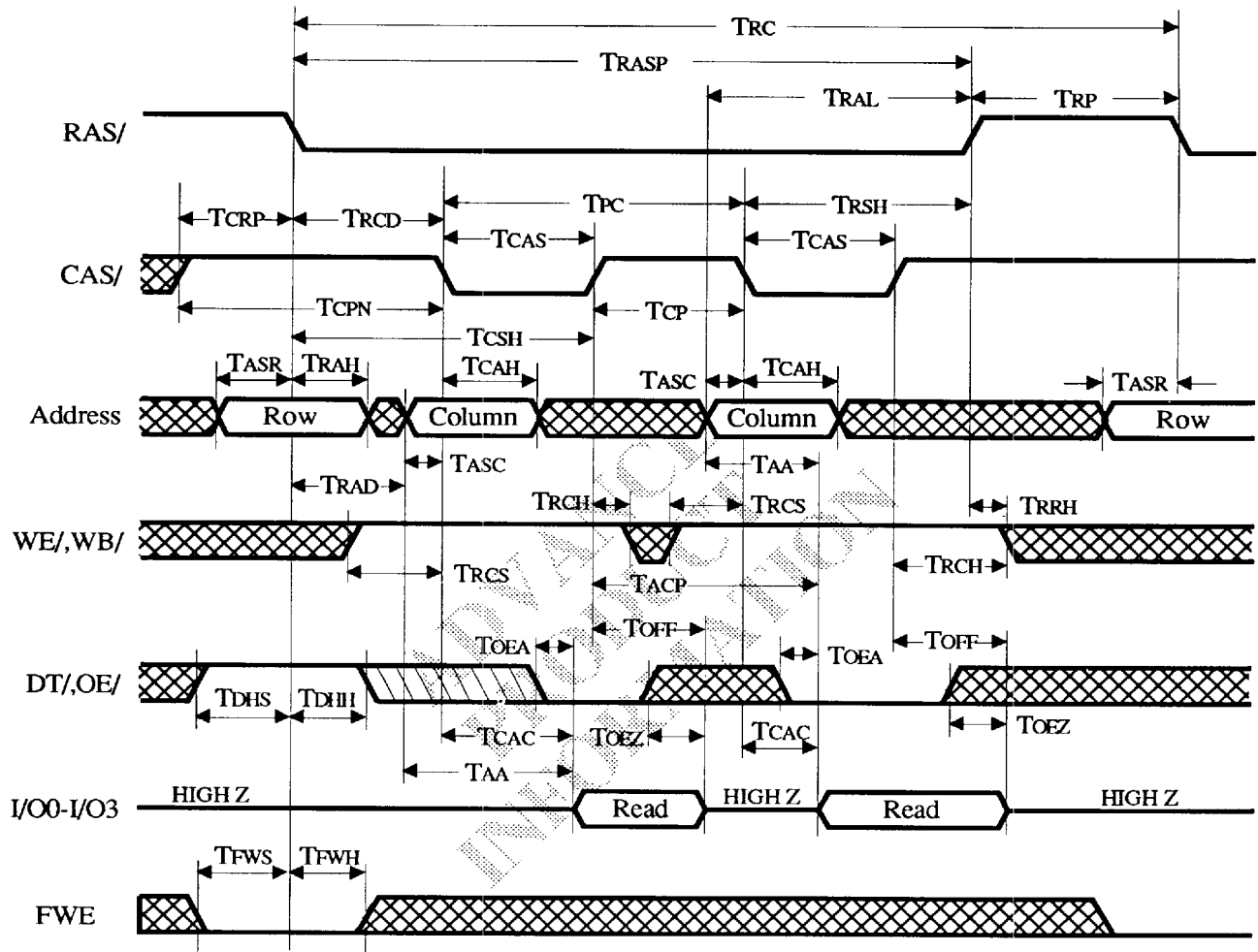

VRAM Fast-page Read Cycle Timing

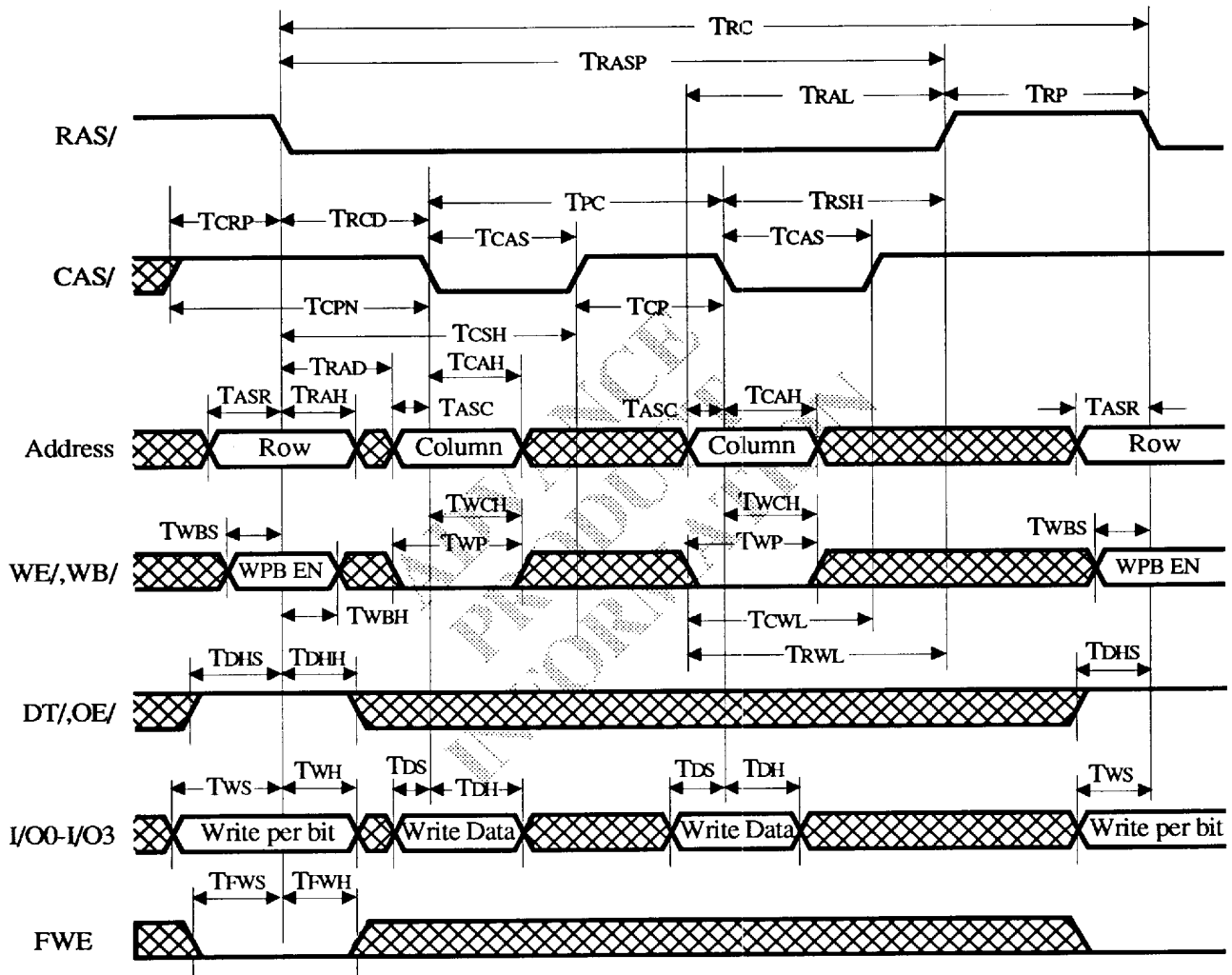

VRAM Fast-page Write Cycle Timing

T-52-33-45

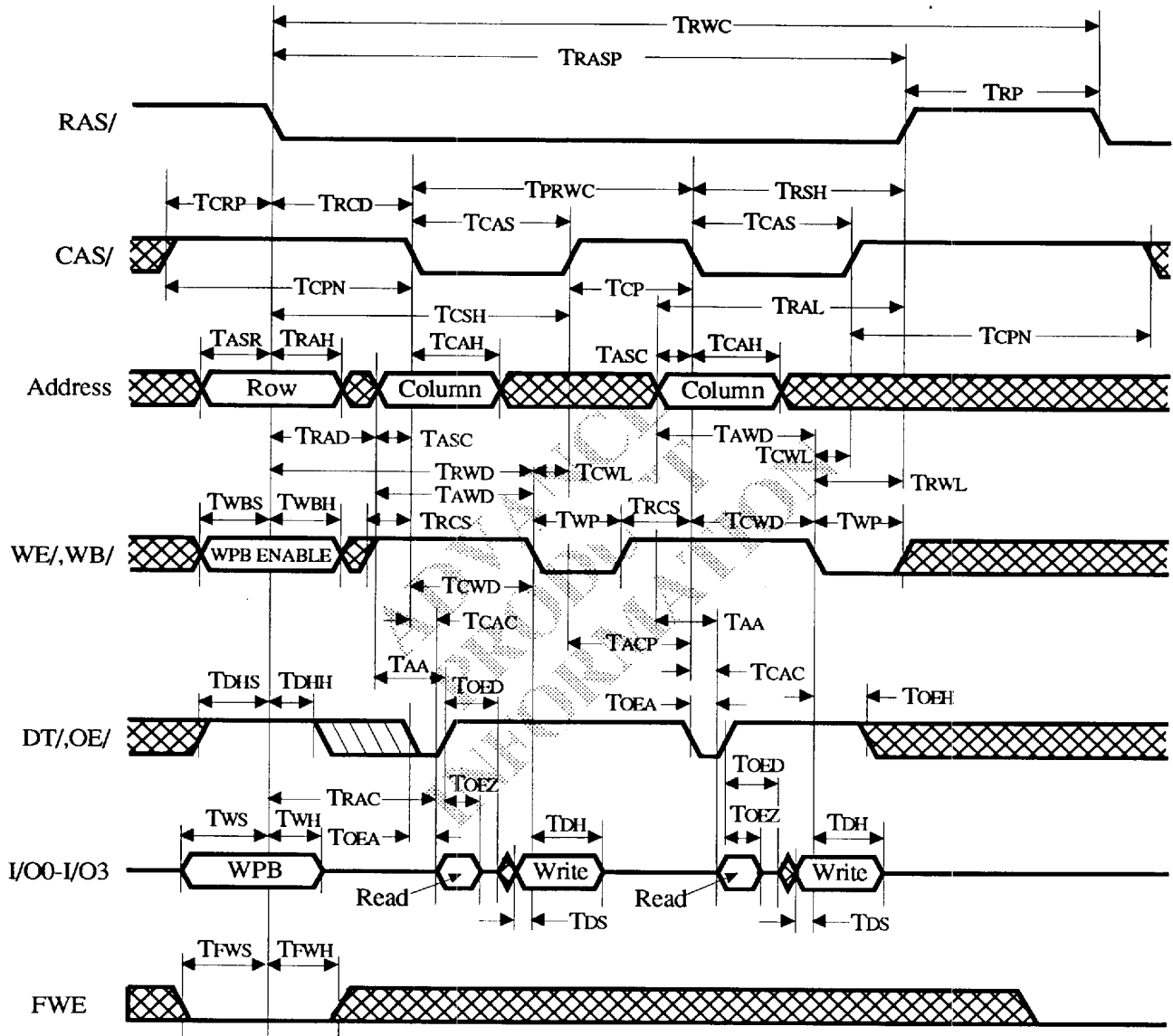

VRAM Fast-page Read-Modify-Write Cycle Timing

T-52-33-45

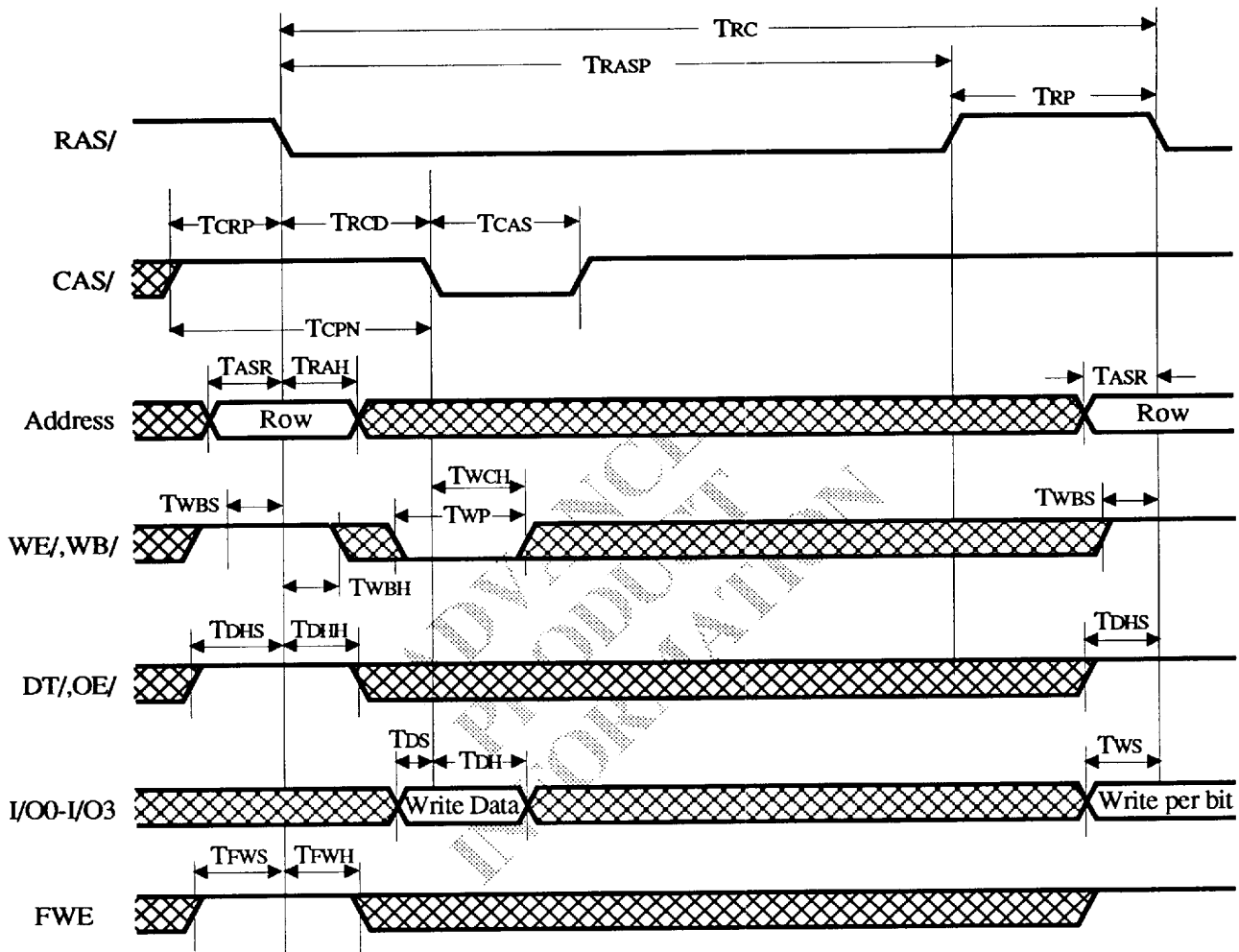

VRAM Color Register Set Cycle Timing

T-52-33-45

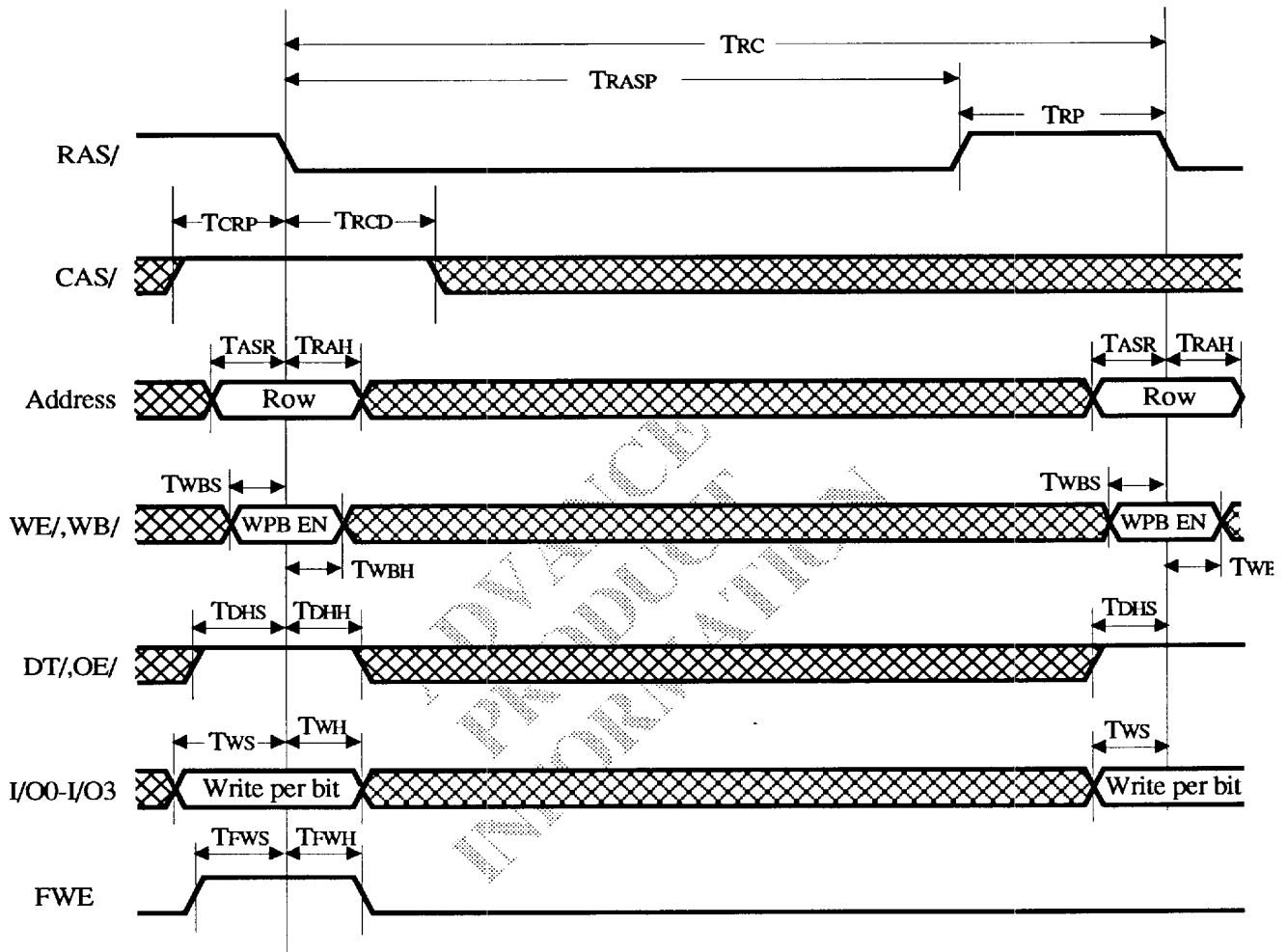

VRAM Flash Write Cycle Timing



T-52-33-45

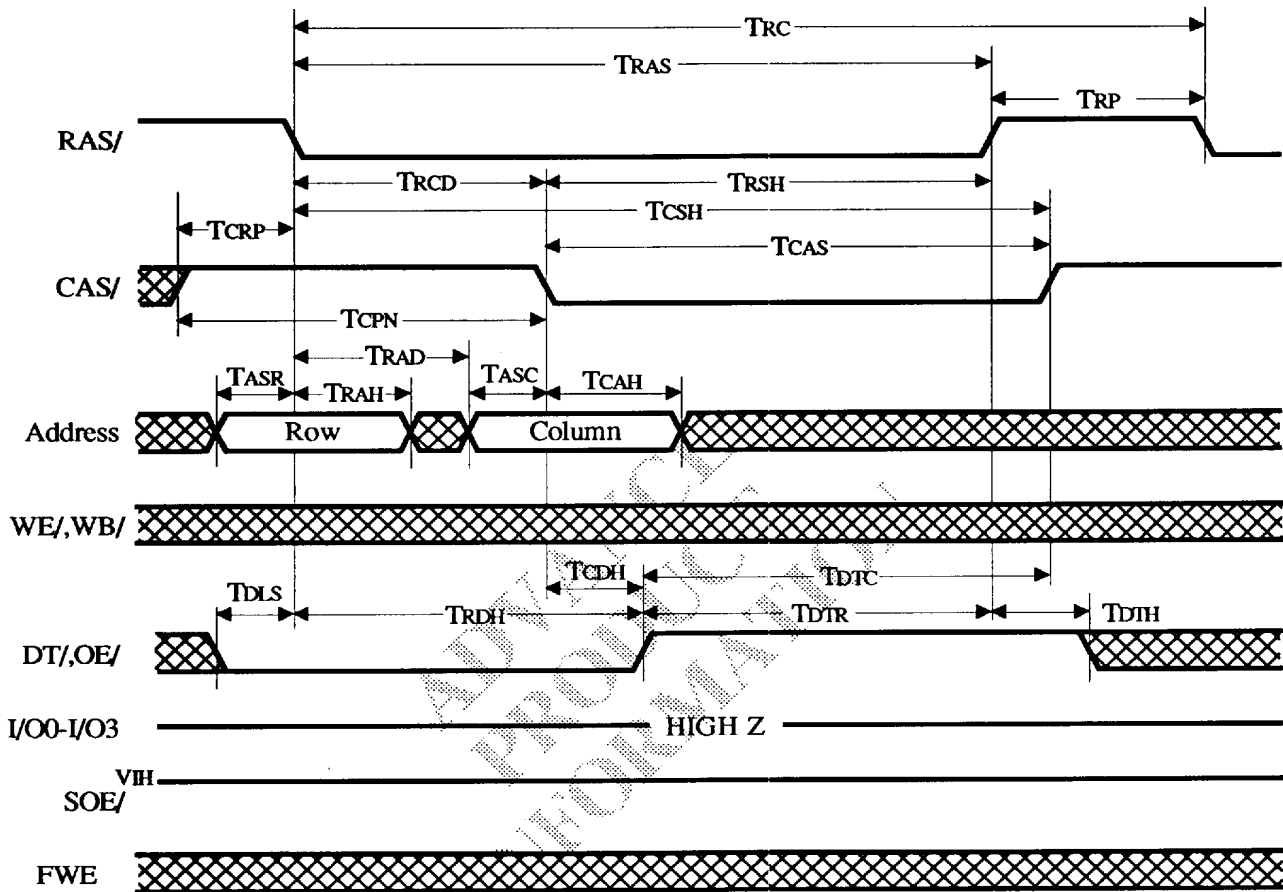

VRAM Data Transfer Cycle Timing

T-52-33-45

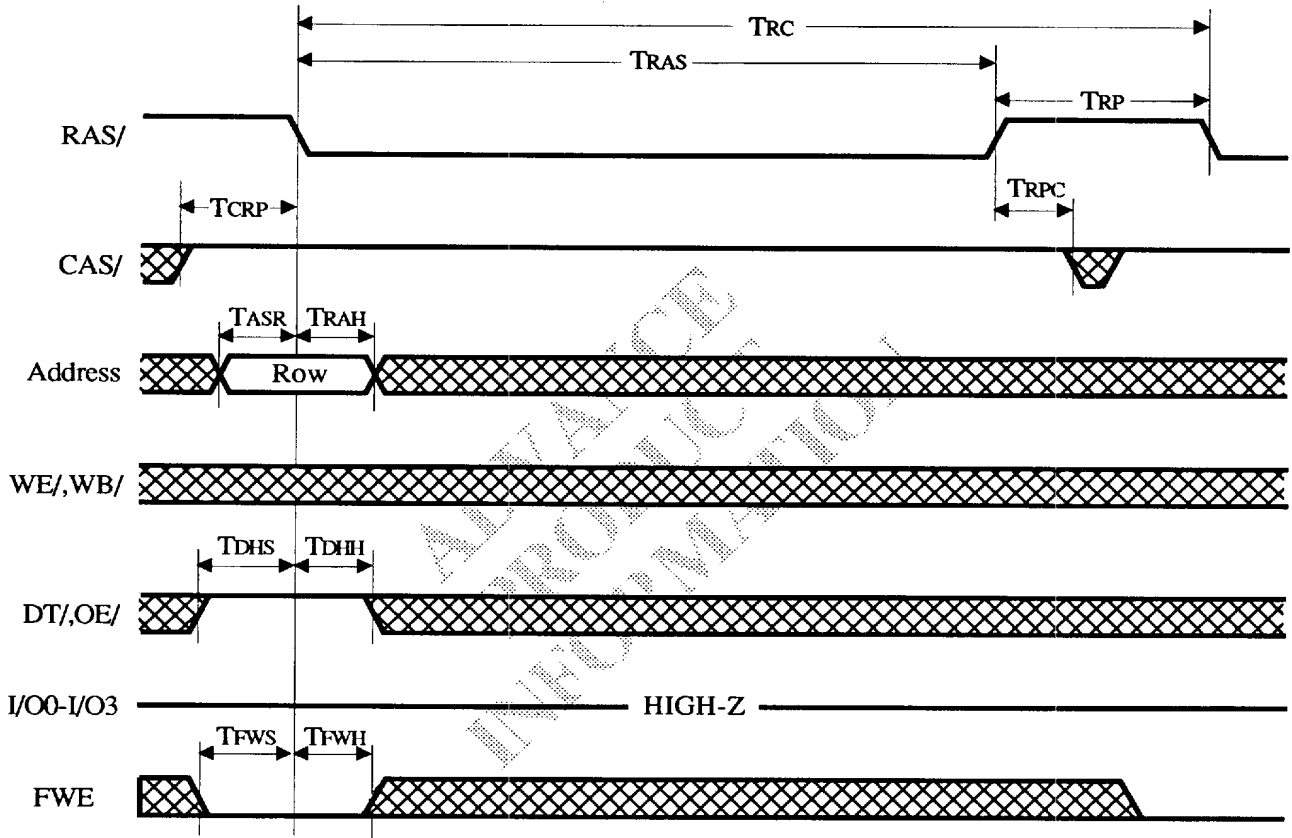

VRAM Refresh Cycle Timing



T-52-33-45

AC TIMING CHARACTERISTICS - VIDEO TIMING

Symbol	Parameter	Notes	Min	Max	Units
T_{VSH}	VSYNC delay from NCLK		-	25	nS
T_{VSV}	VSYNC delay from VVSYNC		-	25	nS
T_{HSN}	HSYNC delay from NCLK		-	25	nS
T_{HSV}	HSYNC delay from VHSYNC		-	25	nS

Output load $C_L = 50pF$ unless otherwise noted.

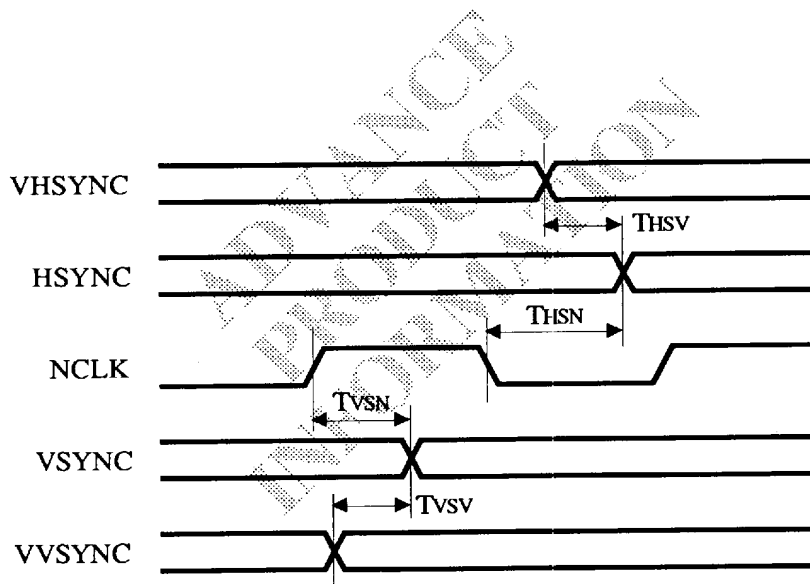

82C481 Video Timing



T-52-33-45

Video Register Parameters

Standard 8514/a Compatible Video Modes

Register Name	I/O Address	640x480 (Non-Interlaced)	640x480 Pseudo-8	1024x768 (Interlaced)	1024x768 (Non-Interlaced)
ADVFUNC_CNTL	4AE8	0003	0003	0007	0001
DISP_CNTL	22E8	0023	0021	0033	0023
MEM_CNTL	BEE8[5]	5006	5002	5006	5006
H_TOTAL	02E8	0063	0063	009D	009D
H_DISP	06E8	004F	004F	007F	007F
H_SYNC_STRT	0AE8	0052	0052	0081	0081
H_SYNC_WID	0EE8	002C	002C	0016	0016
V_TOTAL	12E8	0418	0830	0660	0660
V_DISP	16E8	03BB	0779	05FB	05FB
V_SYNC_STRT	1AE8	03D2	07A8	0600	0600
V_SYNC_WID	1EE8	0022	0022	0008	0008
SCISSORS_T	BEE8[1]	1000	1000	1000	1000
SCISSORS_L	BEE8[2]	2000	2000	2000	2000
SCISSORS_B	BEE8[3]	31DF	31DF	32FF	32FF
SCISSORS_R	BEE8[4]	427F	427F	43FF	43FF
EC2	5AE8	x4xx	x4xx	x4xx	x4xx

8BPP Extended Video Modes

Register Name	I/O Address	1280x1024 (Interlaced)	1280x1024 (Non-Interlaced)	1600x1200 (Non-Interlaced)
ADVFUNC_CNTL	4AE8	0001	0001	0001
DISP_CNTL	22E8	0033	0023	0023
MEM_CNTL	BEE8[5]	5006	5006	5006
H_TOTAL	02E8	00C3	00D7	00FF
H_DISP	06E8	009F	009F	00C7
H_SYNC_STRT	0AE8	00A1	00A2	00C9
H_SYNC_WID	0EE8	001B	0016	0013
V_TOTAL	12E8	0918	0848	0A29
V_DISP	16E8	07FB	07FB	085B
V_SYNC_STRT	1AE8	0800	07FB	0961
V_SYNC_WID	1EE8	000C	0023	0024
SCISSORS_T	BEE8[1]	1000	1000	1000
SCISSORS_L	BEE8[2]	2000	2000	2000
SCISSORS_B	BEE8[3]	33FF	33FF	37FF
SCISSORS_R	BEE8[4]	427F	427F	47FF
EC2	5EE8	x5xx	x5xx	x7xx



16BPP Extended Video Modes

Register Name	I/O Address	640x480 (Non-Interlaced)	1024x768 (Non-Interlaced)	1280x1024 (Non-Interlaced)
ADVFUNC_CNTL	4AE8	—	—	—
DISP_CNTL	22E8	0021	0023	0021
MEM_CNTL	BEE8[5]	5002	5006	5002
H_TOTAL	02E8	0063	009D	00D7
H_DISP	06E8	004F	007F	009F
H_SYNC_STRT	0AE8	0052	0081	00A2
H_SYNC_WID	0EE8	002C	0016	0016
V_TOTAL	12E8	0418	0660	0848
V_DISP	16E8	03BB	05FB	07FB
V_SYNC_STRT	1AE8	03D2	0600	07FB
V_SYNC_WID	1EE8	0022	0008	0023
SCISSORS_T	BEE8[1]	1000	1000	1000
SCISSORS_L	BEE8[2]	2000	2000	2000
SCISSORS_B	BEE8[3]	31DF	32FF	33FF
SCISSORS_R	BEE8[4]	427F	43FF	427F
EC2	5AE8	x4xx	x5xx	x4xx

32BPP Extended Video Modes

Register Name	I/O Address	512x512 (Non-Interlaced)	640x480 (Non-Interlaced)	1024x768 (Non-Interlaced)
ADVFUNC_CNTL	4AE8	—	—	—
DISP_CNTL	22E8	0021	0021	0021
MEM_CNTL	BEE8[5]	5002	5002	5002
H_TOTAL	02E8		0063	009D
H_DISP	06E8		004F	007F
H_SYNC_STRT	0AE8		0052	0081
H_SYNC_WID	0EE8		002C	0016
V_TOTAL	12E8		0418	0660
V_DISP	16E8		03BB	05FB
V_SYNC_STRT	1AE8		03D2	0600
V_SYNC_WID	1EE8		0022	0008
SCISSORS_T	BEE8[1]	1000	1000	1000
SCISSORS_L	BEE8[2]	2000	2000	2000
SCISSORS_B	BEE8[3]	31FF	31DF	32FF
SCISSORS_R	BEE8[4]	41FF	427F	43FF
EC2	5EE8	x4xx	x5xx	x7xx

T-52-33-45

Mechanical Specifications

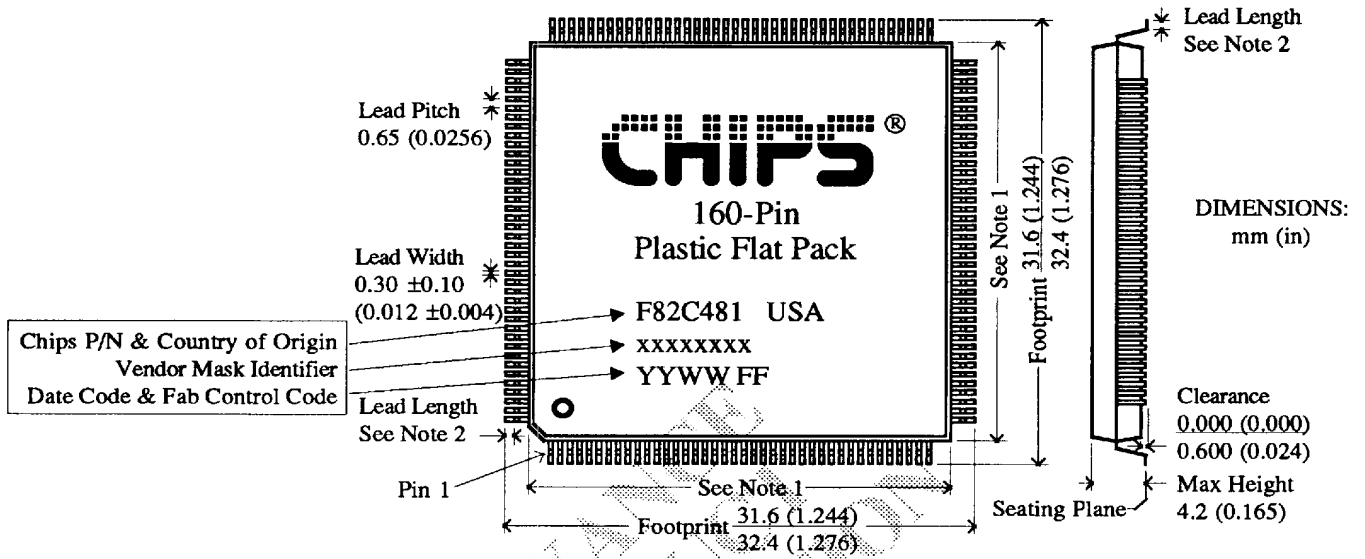

Note 1: Package Body Size = 28 ± 0.2 (1.102 ± 0.008)

Note 2: Lead Length = $\pm 0.8 \pm 0.2$ (0.031 ± 0.008)

Suggested PCB Pad Layout

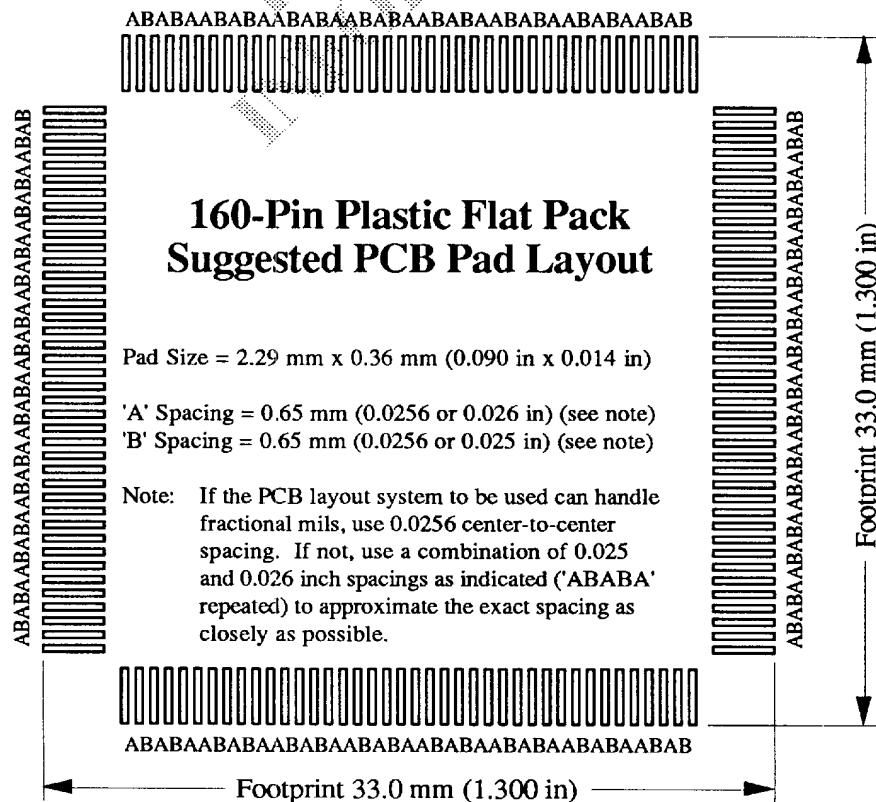

Pad Size = 2.29 mm x 0.36 mm (0.090 in x 0.014 in)

'A' Spacing = 0.65 mm (0.0256 or 0.026 in) (see note)

'B' Spacing = 0.65 mm (0.0256 or 0.025 in) (see note)

Note: If the PCB layout system to be used can handle fractional mills, use 0.0256 center-to-center spacing. If not, use a combination of 0.025 and 0.026 inch spacings as indicated ('ABABA' repeated) to approximate the exact spacing as closely as possible.