

APPENDIX A

CALCOMP

140 FLOPPY DISK DRIVE

OEM REFERENCE MANUAL

1975 EDITION

The following 50 pages is reproduced with the kind permission of California Computer Products, Inc., Anaheim, California.

The following 50 pages is reproduced with the
permission of California Computer Products,
San Jose, California.

APR 1974
42
3000

**This Document was scanned and
contributed by:**

Barry A. Watzman

CONTENTS

INTRODUCTION	1
Scope	1
Related Documents	1
General Description	1
PRODUCT DESCRIPTION	2
Summary of Specifications	2
Features	2
Options	3
FUNCTIONAL DESCRIPTION	4
General	4
Spindle Drive	4
Track Accessing	4
Read/Write Head	5
Flexible Disk	6
Flexible Disk Environment	7
Recording Format	8
Full Track Format	8
32 Sector Format	9
IBM 3740 Format	9
RELIABILITY	11
Service Life	11
Mean Time Between Failure (MTBF)	11
Mean Time to Repair (MTTR)	11
Preventive Maintenance	11
Recoverable Read Error Rate	11
Non-Recoverable Read Error Rate	12
Access Positioning Error Rate	12
Error Correction	12
Environmental Requirements	13
Cleanliness and Air Filter	14
Underwriter Approval	15
OPERATOR CONTROL	15
POWER REQUIREMENTS	15
Power Sequencing	15
AC Power	15
Spindle Motor Amperage	16
DC Power	16
CABLE CONNECTIONS	16
AC Power Cable	16
DC/Signal Cable	17

INPUT SIGNALS	20
OUTPUT SIGNALS	21
INTERFACE CIRCUITS	22
Interface Signal Levels	22
CONFIGURATIONS	25
INTERFACE TIMING	29
Track Positioning	29
Read Data Timing	31
Write Data Timing	32
Index/Sector Timing	33
Power-On to Data Transfer	33
DATA SEPARATOR OPTION WIRING	36
Raw Data Output	37
One-Shot Output	37
PHYSICAL DIMENSIONS	37
ACCESSORIES	38
OPERATING PROCEDURES	39
Flexible Disk Handling	39
Write Protect Option	40
Flexible Disk Loading	40

15
 16
 17
 18
 19
 20
 21
 22
 23
 24
 25
 26
 27
 28
 29
 30
 31
 32
 33
 34
 35
 36
 37
 38
 39
 40
 41
 42
 43
 44
 45
 46
 47
 48
 49
 50
 51
 52
 53
 54
 55
 56
 57
 58
 59
 60
 61
 62
 63
 64
 65
 66
 67
 68
 69
 70
 71
 72
 73
 74
 75
 76
 77
 78
 79
 80
 81
 82
 83
 84
 85
 86
 87
 88
 89
 90
 91
 92
 93
 94
 95
 96
 97
 98
 99
 100

101
 102
 103
 104
 105
 106
 107
 108
 109
 110
 111
 112
 113
 114
 115
 116
 117
 118
 119
 120
 121
 122
 123
 124
 125
 126
 127
 128
 129
 130
 131
 132
 133
 134
 135
 136
 137
 138
 139
 140
 141
 142
 143
 144
 145
 146
 147
 148
 149
 150
 151
 152
 153
 154
 155
 156
 157
 158
 159
 160
 161
 162
 163
 164
 165
 166
 167
 168
 169
 170
 171
 172
 173
 174
 175
 176
 177
 178
 179
 180
 181
 182
 183
 184
 185
 186
 187
 188
 189
 190
 191
 192
 193
 194
 195
 196
 197
 198
 199
 200

- **Data Outputs**

Choice of two read data outputs are provided as standard.

For the systems designer who desires a more efficient coding technique or chooses to separate data and clocks, raw data output representing unseparated clocks and data is provided.

For the systems designer who desires the drive to separate data, NRZ data and clock strobe outputs are provided by a one-shot decoder.

For the systems designer who desires IBM 3740 media interchangeability, an optional phase lock loop is offered. The PLL outputs separated data pulses and separated clock pulses.

- **Positive Pressurization**

A self-contained air system draws in, filters and controls air flow, providing positive pressurization in the media chamber. Provides greater reliability with cleaner head, media and moving parts.

- **Packaging**

Physical dimensions of the unit provide capability of mounting two units horizontally or three units vertically within a standard 19 inch RETMA rack.

- **Mounting**

The CalComp 140 is designed so that it may be mounted in any plane without degradation of performance or reliability. In the horizontal plane only "handle up" orientation is recommended.

- **Power Requirements**

Requires only two DC power inputs, +5V and +24V. Enables simpler and less expensive controller power supply.

No-charge AC power options provide for worldwide applications.

Options

- **Phase Lock Loop Data Separator**

In addition to highest data integrity, provides capability of detecting missing clocks as used with IBM 3740-type address marks. Separated data and separated clock outputs are coincident, enabling a simple "ORing" of the two to detect missing clocks.

- **Write Protect**

Provides for protection of data via the use of a hole in the flexible disk protective jacket. Option is designed as fail safe as tab is a "write enable" device. Should the tab be inadvertently removed, the flexible disk is automatically protected against destruction of data.

- **Sector Outputs**

32 hard sector holes are punched in the index track. Provides for OEM data formats.

10877

102 9

FUNCTIONAL DESCRIPTION

General

The CalComp 140 contains an electronics PWB, flexible disk drive system, read/write head positioning mechanism and necessary transducers. These elements combine to accomplish the following:

- Interpret input interface signals
- Position read/write head to desired track
- Read from or write data onto flexible disk
- Provide status information to host controller

All electronics are contained on a single printed circuit board. This PCB contains the following circuits:

- Input interface receivers
- Stepper motor control and drive circuits
- Index detection logic
- Sector detection logic
- Write protect detection logic
- Track 00 detection logic
- Head load actuator control and drive circuit
- Read circuit
- Data separator circuit
- Write circuit
- Output interface drivers

Spindle Drive

The flexible disk is driven at 360 RPM by a spindle which is attached by a drive belt to an AC drive motor. A registration hub is located on the chassis that precisely registers the flexible disk by the use of an expansion centering cone. As the cover is closed the centering cone expands, precisely registering the flexible disk on the drive spindle.

Track Accessing

The read/write head is moved to the correct track in response to input interface lines DIRECTION and STEP/. Each step pulse causes the stepper motor to rotate clockwise or counterclockwise in 30° increments, as defined by the state of the direction line. As the head is mounted on a carriage driven by the stepper motor helical shaft, each 30° rotational movement is converted to 0.021 inch linear movement (one track).

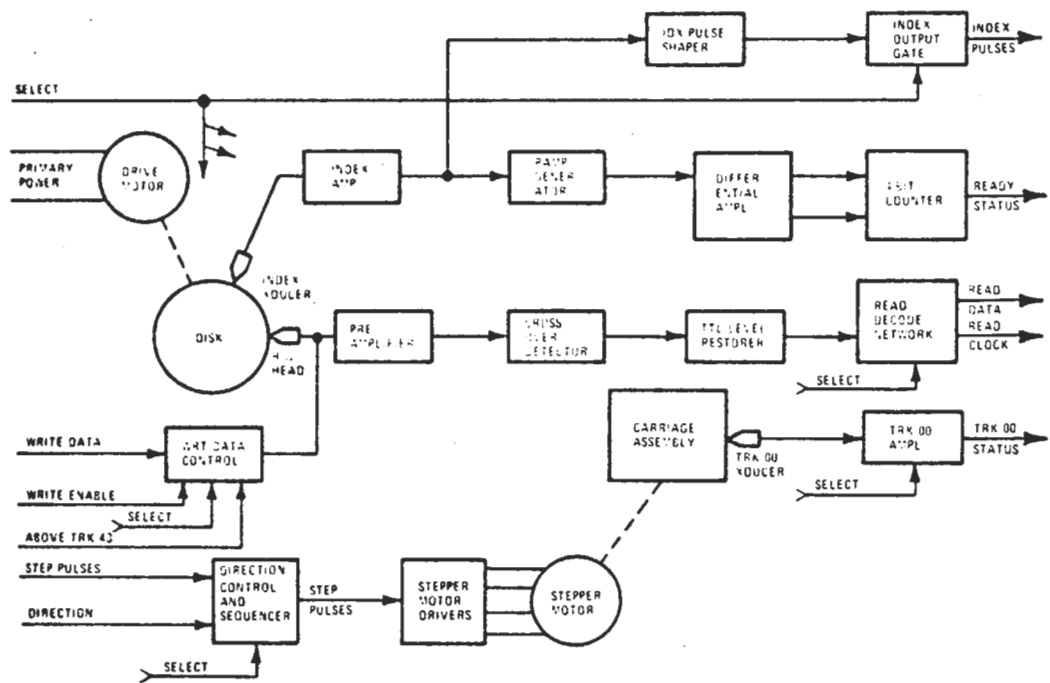

FIGURE 1, CALCOMP 140 BLOCK DIAGRAM

As the last step pulse is issued, the media is loaded against the head by the interface line HEAD LOAD/ in preparation for data transfer. The time required to move the last track is 6 MS, 10 MS is required for head mechanical stabilization, media loading time is 16 MS. Thus, by loading the media simultaneously with issuing the last step pulse, media loading time occurs during the time required for stepping the last track and mechanical stabilization of the head. Since media load time is not a factor in latency, higher throughput results.

Read/Write Head

The CalComp 140 uses a single element read/write head precisely designed to provide maximum signal playback with minimal wear. The head also contains a tunnel erase coil to provide erased areas between data tracks to compensate for normal tolerances between flexible disks and disk drives. These erased areas ensure media interchangeability as well as high data integrity.

The read/write head is mounted on a carriage which is driven by the stepper motor helical shaft. The head is precisely held in a plane perpendicular to the flexible disk, ensuring perfect head to media compliance. The flexible disk is loaded against the head in response to the input interface signal HEAD LOAD/ (see Figure 2).

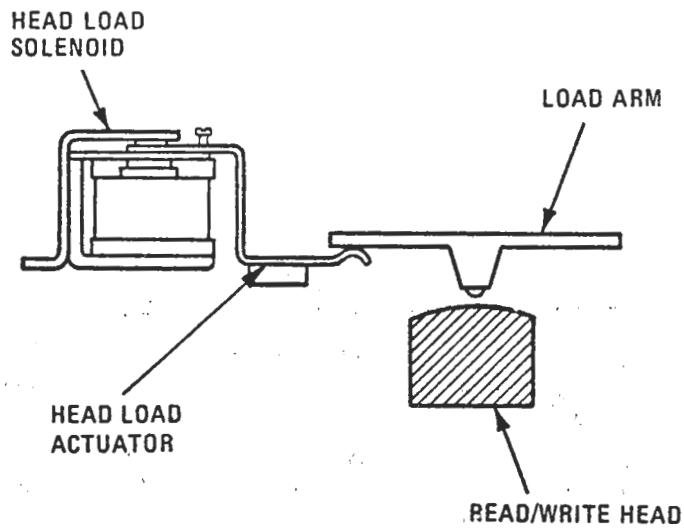
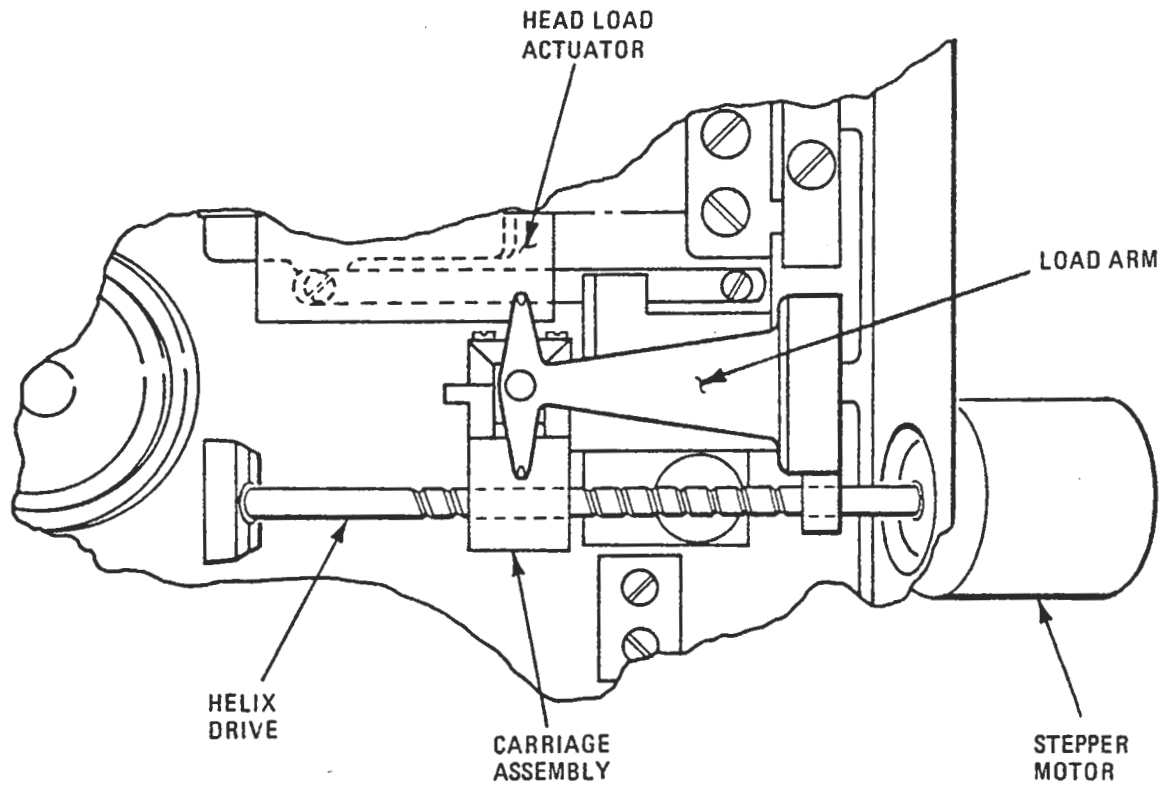

FIGURE 2. CARRIAGE ASSEMBLY

Flexible Disk

Recording media specified for use with the CalComp 140 is an oxide coated flexible disk enclosed within a protective plastic envelope. The protective envelope contains apertures for spindle loading, head contact and sector/index detection.

The recommended flexible disk is the IBM 3740 Diskette or CalComp approved equivalent. Flexible disk characteristics are as follows.

Disk Diameter	7.875 inches
Envelope Size	8 x 8 inches
Rotational Speed	360 RPM $\pm 2.5\%$
Rotational Period	166.67 MS $\pm 2.5\%$
Average Latency	83.33 MS
Tracks	77
Track Density	48 TPI
Bit Density	3200 BPI (INSIDE TRACK)

Flexible Disk Environment

Flexible disks must be in the same temperature and humidity environment as the disk drive for a minimum of 5 minutes prior to installation of the flexible disk into the disk drive.

Temperature	50 ^o F to 125 ^o F, maximum gradient of 20 ^o F per hour
Relative Humidity	8% to 80%, maximum wet bulb 85 ^o F

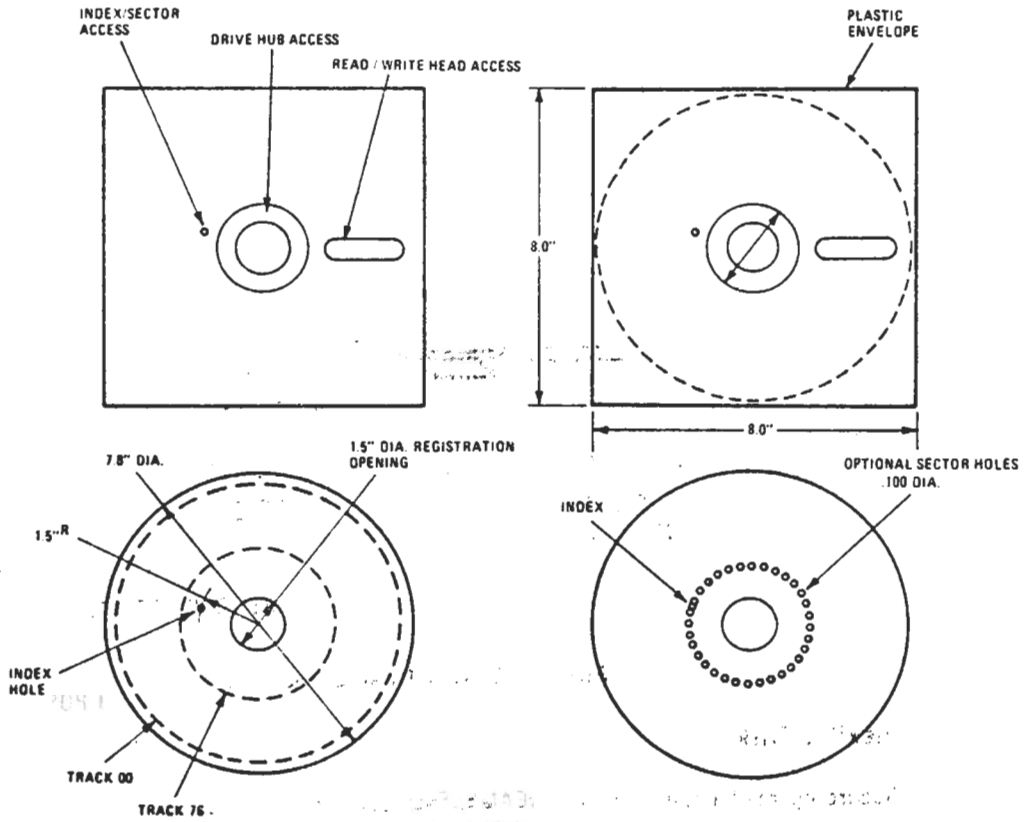

FIGURE 3. FLEXIBLE DISK DIMENSIONS

32 Sector Format

Figure 6 depicts a typical 32 sector format. This format is the least efficient OEM format due to the number of gaps required between data records, but is more efficient than the IBM 3740 data format. This format provides approximately 2.6 million bits of useful data storage.

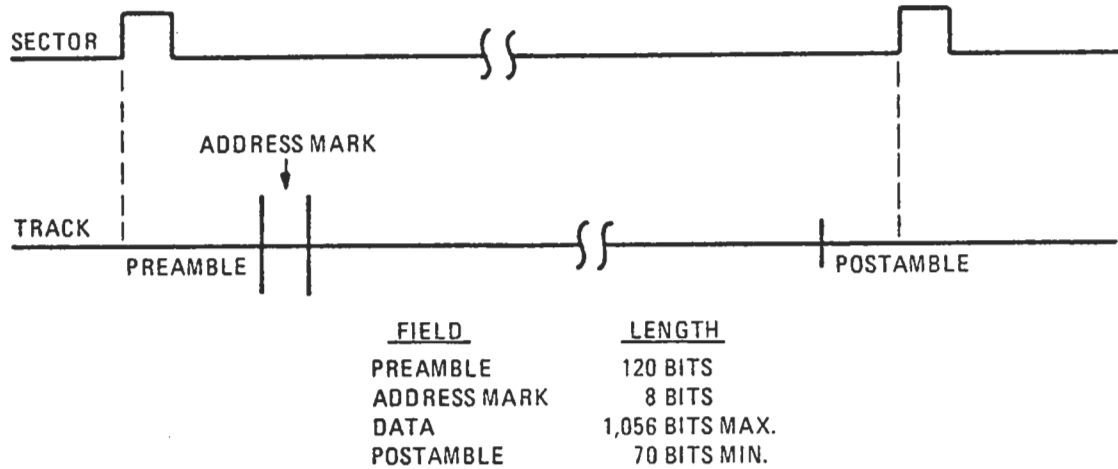

FIGURE 6. 32 SECTOR FORMAT

IBM 3740 Format

Figures 7 and 8 depict data formats as used with the IBM 3740 series of data recording equipment. The 3740 utilizes two formats. Track 00 contains Data Set Labels which contain descriptive information regarding data residing on tracks 01 through 76.

Tracks 01 through 73 and 75 and 76 contain 26 sectors each of 128 data bytes. Track 74 is not used. These sectors are grouped into Data Sets. A Data Set may be one or more sectors including overflowing onto other flexible disks. This format provides approximately 1.9 million bits of useful data storage.

For detailed data format and initialization information refer to IBM publication GA21-9190.

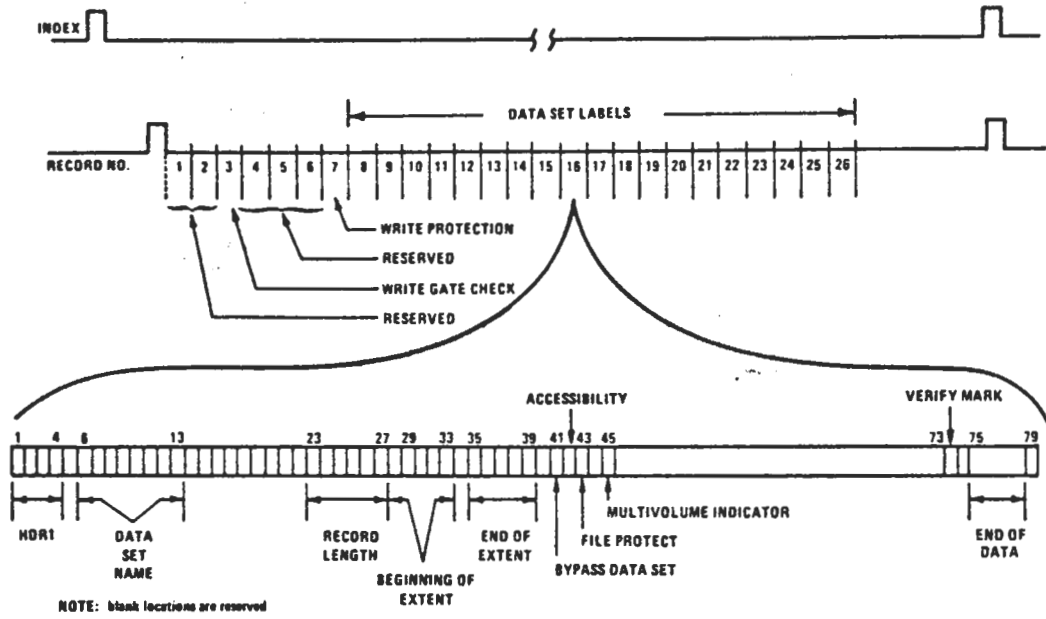

FIGURE 7, IBM DATA SET LABEL FORMAT

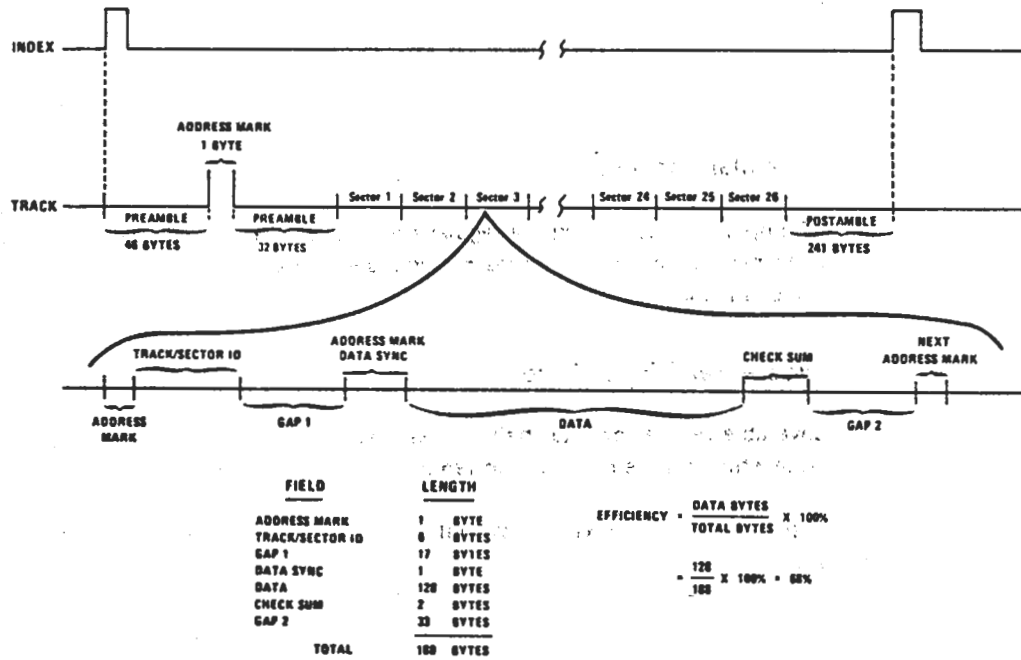

FIGURE 8, IBM TRACK FORMAT

RELIABILITY

Service Life

The CalComp 140 is designed and constructed to provide a useful life of 5 years or 30,000 hours, whichever occurs first, before a factory overhaul or replacement is required. Repair or replacement of parts will be permitted during the lifetime of the unit

Mean Time Between Failure (MTBF)

Following an initial period of 200 hours, MTBF is expected to exceed 5,000 hours. The following expression defines MTBF:

$$\text{MTBF} = \frac{\text{Operating Hours}}{\text{Number of Equipment Failures}}$$

Operating hours mean total "power-on" hours less any maintenance time. Equipment failures mean any stoppage or substandard performance of the unit because of equipment malfunction. Equipment failure shall exclude downtime or substandard performance due to operator error, adverse environment, power failure, or other failures not caused by the drive. To establish a meaningful MTBF operating hours must be greater than 2,500 hours and shall include all sites where the drives are used.

Equipment failures are defined as those actions requiring repairs, adjustments or replacements on an unscheduled basis, i.e., emergency maintenance is required because of hardware failure or substandard performance.

Mean Time to Repair (MTTR)

MTTR shall be less than 0.5 hours, and is defined as the time required for an adequately trained and competent serviceman to diagnose and correct a malfunction.

Preventive Maintenance

The CalComp 140 does not require regular preventive maintenance. For those OEMs who desire to perform periodic checks, a suggested schedule is available in the Model 140 Operation and Maintenance Manual.

Recoverable Read Error Rate

The recoverable read error rate shall be less than one error in 10^9 bits read. A recoverable read error is one which can be recovered in ten or less attempts to read the record.

Errors attributed to the flexible disk will not be included in determining the recoverable read error rate.

Non-Recoverable Read Error Rate

The non-recoverable read error rate shall be less than one error in 10^{12} bits read. A non-recoverable read error is one which remains after ten unsuccessful attempts to read the record.

Errors attributed to the flexible disk will not be included in determining the non-recoverable read error rate.

Access Positioning Error Rate

Provided proper interface timing requirements are followed, the access positioning error rate shall be less than one error per 10^6 positioning operations.

Error Correction

Write Errors

Write errors are usually detected as read errors and are sometimes difficult to identify. For those applications desiring the highest data reliability and are able to implement a "write/verify" operation (write and check read), the following procedure is recommended, assuming a read error was encountered during the verify portion.

- Perform up to 10 write/verify operations. If no error was detected, continue with processing.
- If additional errors are encountered, step to a random track and perform a read operation. If no errors occur the drive has an apparent write problem. To verify a problem exists, step to a spare track, if available, and perform the write/verify operation again. If no error occurs the flexible disk is defective. If additional errors occur the drive has a write problem.

Read Errors

The majority of read errors are recoverable by up to 10 attempts to read the record. Recoverable errors are usually caused by:

- Contamination not removed by the flexible disk wiping fabric.
- External random electrical noise.
- Defects in the written data not detected by a write/verify operation.
- Defects in the flexible disk not detected by an initialization routine.

The following procedure is recommended to recover temporary read errors.

- Perform up to 10 read operations to recover the data.
- If data cannot be recovered after ten attempts, step the head to the next track in the same direction as previously moved, then step back to the desired track.
- Repeat the 10 read attempts.
- If the read error still persists, the error is not recoverable.

Positioning Errors

Although positioning errors are rare, they may be recovered by one of two methods:

1. Stepping the head out until the interface line TRACK 00/ becomes active and performing the positioning operation again.
2. Reading the track ID and performing a corrective positioning operation.

Environmental Requirements

The CalComp 140 will provide satisfactory performance when operated within the following environmental parameters.

Temperature

Operating:	60°F to 100°F ambient, maximum gradient of 20°F per hour
Non-operating:	-30°F to 140°F
Heat Dissipation:	275 BTU/hr

Relative Humidity

Operating:	20% to 80%, maximum wet bulb 78°F
Non-operating:	5% to 98%, no condensation

Shock

Non-operating:	The CalComp 140 will not suffer damage nor fail to perform as specified when subjected to 18 impact shocks of 5G's ($\pm 10\%$) consisting of 3 shocks in opposite directions along each of 3 mutually perpendicular axes. Each shock impulse may have a time duration of 11 (± 1) milliseconds.
----------------	--

Vibration

- Operating:** The unit will withstand a peak displacement of ± 0.005 inch for the frequency range from 5 to 60 Hz and $\pm 2G$'s for the range from 60 to 500 Hz.
- Non-operating:** The unit will withstand 1.5G's from 5 to 55 Hz for four hours on each axis with a 20 minute frequency span (no external packaging or internal bracing required).

Altitude

- Operating:** Mean sea level to 10,000 feet
- Non-operating:** 1,000 feet below sea level to 15,000 feet above sea level.

Cleanliness and Air Filter

The CalComp 140 does not normally require periodic cleaning of the chassis or read/write head. Each flexible disk contains a special wiping fabric within its protective envelope to remove and trap excess oxide or foreign debris from the surface of the disk.

Should the read/write head require cleaning due to the continued use of a fully contaminated flexible disk, the head may be cleaned using lintless gauze dampened with 91% isopropyl alcohol. After cleaning, the head should be wiped with a clean, dry gauze to remove any residue left when the alcohol evaporates.

The CalComp 140 is equipped with a positive pressure air system. A fan attached to the spindle drive motor serves to draw air through a filter located at the rear of the unit and pass this air across the flexible disk. The function of this system is to control and filter air within the unit in order to provide the highest possible reliability. The air system is in constant operation including during flexible disk removal and replacement.

Since the CalComp 140 is used in numerous applications with varying environmental conditions, a recommended air filter replacement schedule is not provided. The systems designer or maintenance planner should be advised of the positive pressure system and take action appropriate to his particular application.

Underwriter Approval

The CalComp 140 is UL recognized. The systems designer should consult appropriate regulations as a part of implementing the drive into his system.

OPERATOR CONTROL

The simplicity of the CalComp 140 precludes the necessity of operator controls and indicators. A convenient method of opening the unit for flexible disk insertion and removal is provided. In the center of the face of the unit is a simple, thumb-operated pushbutton which is depressed to allow the spring-loaded front cover to open. The flexible disk may be inserted or removed, as appropriate. The cover may then be closed manually. The front cover is automatically locked shut (see Figure 9).

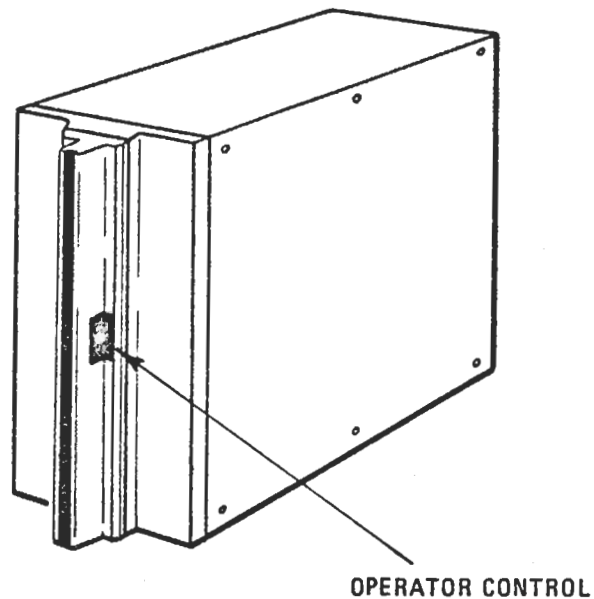

FIGURE 9. OPERATOR CONTROL

POWER REQUIREMENTS

Power Sequencing

The CalComp 140 is designed so that all AC and DC voltages may be applied or removed in any sequence.

AC Power

50 Hz \pm 0.5 Hz, single phase	60 Hz \pm 0.5 Hz, single phase
100 VAC \pm 10% (-007)	100 VAC \pm 10% (-005)
208 VAC \pm 10% (-008)	115 VAC \pm 10% (-001)
220 VAC \pm 10% (-003)	208 VAC \pm 10% (-006)
240 VAC \pm 10% (-004)	230 VAC \pm 10% (-002)

Spindle Motor Amperage

50 Hz \pm 0.5 Hz, Voltage \pm 10%

Voltage	Nominal Start	High Start	Nominal Run	High Run
100 VAC	1.26	1.50	0.95	1.10
208 VAC	0.65	0.80	0.48	0.60
220 VAC	0.75	1.00	0.56	0.70
240 VAC	0.71	0.90	0.57	0.75

60 Hz \pm 0.5 Hz, Voltage \pm 10%

Voltage	Nominal Start	High Start	Nominal Run	High Run
100 VAC	1.40	1.70	0.85	1.00
115 VAC	1.32	1.60	0.89	1.20
208 VAC	0.75	0.90	0.42	0.60
230 VAC	0.64	0.90	0.45	0.55

DC Power

+ 5 VDC \pm 2% @ 1.0 amps, maximum

+24 VDC \pm 5% @ 1.5 amps, maximum

CABLE CONNECTIONS

AC Power Cable

Connector

AC power is supplied to JO on the rear of the unit (see Figure 10). The mating connector and pins required for connection via No. 18 AWG are supplied with each unit. Connector information is as follows:

AC power connector (on unit)	P/N 90605-003
Mating connector *	P/N 90606-003 (MOLEX 1396R)
Mating contacts (3 req) *	P/N 90441-002 (MOLEX 1381-ATL)

*Supplied with each unit.

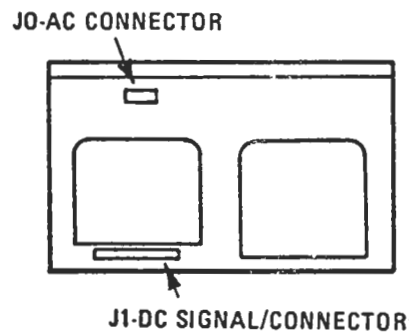

FIGURE 10. CONNECTOR LOCATIONS

PO Pin Assignments

Phase to Phase: PO-1 – input AC
PO-2 – chassis ground
PO-3 – input AC

Phase to Neutral: PO-1 – input AC
PO-2 – chassis ground
PO-3 – AC return

–NOTE–

With phase to phase systems pins 1 and 3 should be fused. With phase to neutral systems pin 1 should be fused. For UL approval the unit must draw its power from the host system.

Chassis ground and DC/ signal ground are isolated on the unit.

DC/Signal Cable

General

DC power, control and status information are transmitted between the control unit and the drive via the DC/Signal Cable. The mating connector required to interface with twisted pairs, returns grounded, No. 24 or No. 26 AWG wire is available. Cable twist should be approximately 30 twists per foot with a maximum cable length of 25 feet.

While each drive's interface is identical, provisions have been made whereby each drive may be assigned a unique address and used in a bussed, or daisy chained configuration. This is accomplished by the use of a SELECT line which enables communication between the CalComp 140 and its host controller. Each drive contains the select function and is to be controlled individually in a bussed configuration by the use of unique SELECT lines built into the DC/Signal Cable.

Another unique line is READY. This line is not gated with SELECT and serves as an interrupt to the controller. READY is intended to reduce controller overhead. This line is particularly useful during flexible disk changes.

All other lines are gated by SELECT, including data transfer. In a daisy chained configuration, a terminator PWB is required for the last unit in the chain. In a radial configuration, the terminator PWB is not required unless the DC/Signal Cable length exceeds 5 feet. The DC/Signal Cable is connected to J1 located at the rear of the unit (refer to Figure 10). Connector information is as follows:

DC/Signal connector (on unit)
Mating connector

P/N 95359-040
P/N 95365-140 (CANNON-UBS 130105-0000)

P1 Pin Assignments

WARNING: Pin Assignments according to industry connector convention, not CalComp schematic convention.

Ground Pin	Signal Pin	Signal Nomenclature
P-2	P-1	+5VDC
P-4	P-3	+5VDC
P-6	P-5	DIRECTION
P-8	P-7	STEP/
P-10	P-9	+24V
P-12	P-11	+24V
P-14	P-13	+24V
P-16	P-15	SELECT/
P-18	P-17	TRACK 00/
P-20	P-19	HEAD LOAD/
P-22	P-21	READY/
P-24	P-23	ABOVE TRACK 43/
P-26	P-25	INDEX/
P-28	P-27	SECTOR/
P-30	P-29	WRITE ENABLED/
P-32	P-31	WRITE DATA/
P-34	P-33	WRITE ENABLE/
P-36	P-35	READ DATA
P-38	P-37	READ CLOCK/ (OR RAW DATA)
P-40	P-39	PLO SYNC/

Interface Signal Definitions

All interface lines are low active (OV) unless otherwise specified. Driver and receiver circuits used within the CalComp 140 are DTL and TTL. Controller driver and receiver circuits must provide equivalent voltage and impedance levels for proper signal transmission.

LOW — refers to the low voltage condition commonly encountered with TTL and DTL logic, and corresponds to a voltage in the range of 0.0V to 0.4V.

HIGH — refers to the high voltage condition commonly encountered with TTL and DTL logic, and corresponds to a voltage in the range of 2.2V to 5.5V.

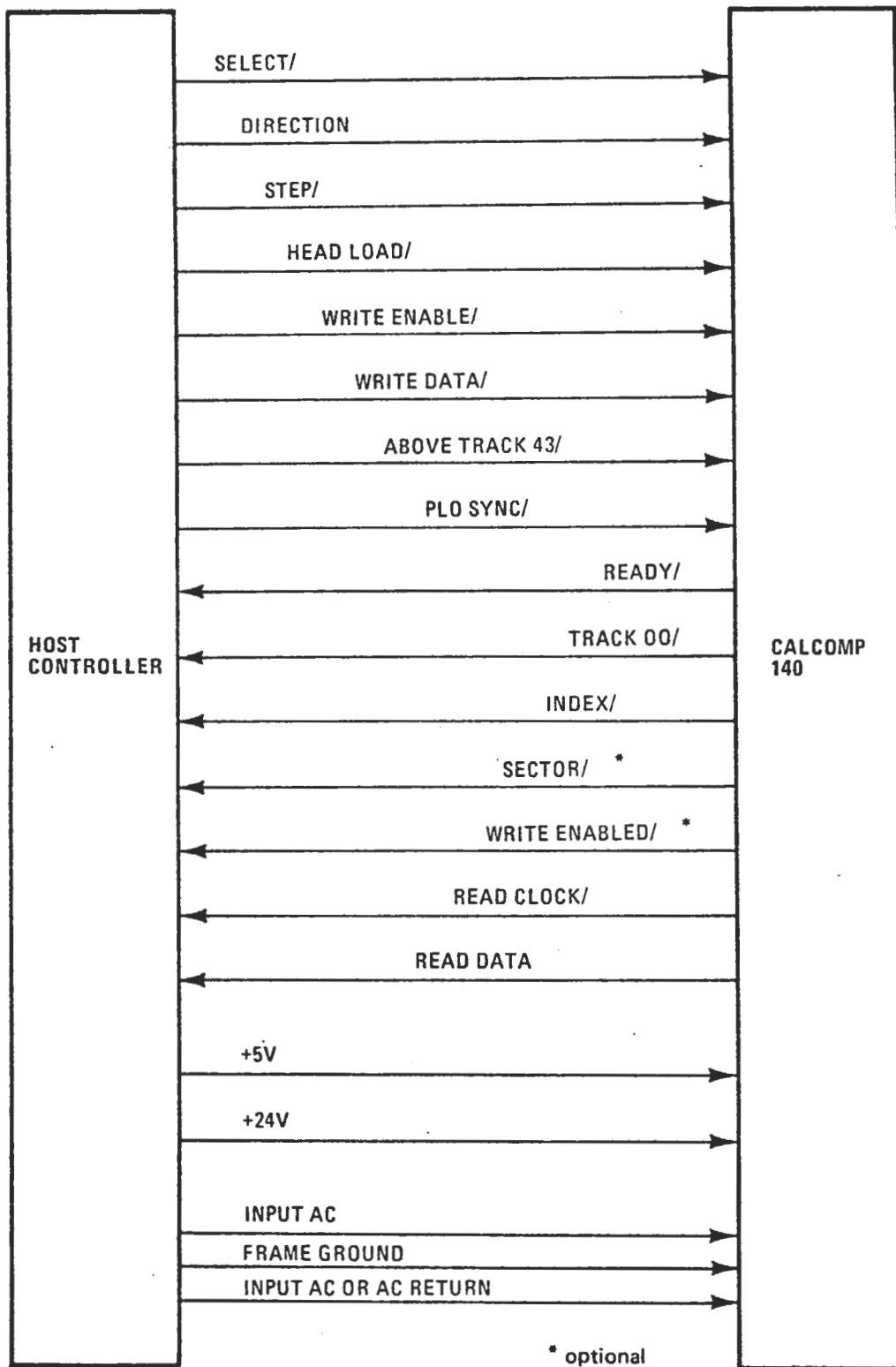

FIGURE 11. INTERFACE LINES

INPUT SIGNALS

The following signals are input to the drive from the host controller:

SELECT/	A unique signal used to enable communication between the drive and its controller. This line must be low (OV) to be active.
DIRECTION	This line is used in conjunction with STEP/ to cause the read/write head to be moved from track to track. When this line is high (5V), direction is IN (higher numbered tracks). When this line is low (OV), direction is OUT (lower numbered tracks). This line must be stable 100 nanoseconds minimum before activating STEP/ and remain in the appropriate state for the duration of the step period.
STEP/	This line is used in conjunction with DIRECTION and is used to cause the read/write head to be moved from track to track. A low pulse (OV) of 200NS to 2MS causes the head to be moved one track in the direction specified by the DIRECTION line. Step rate is 167 steps per second (6 milliseconds per step).
HEAD LOAD/	This line is used to move the flexible disk against the read/write head for data recording or retrieval. This line must be low (OV) to be active. A 16 millisecond delay is required after activating this line to allow for media loading prior to commencing data transfer.
WRITE ENABLE/	Enables recording of data on the flexible disk. This line must be low (OV) to be active. When this line is high (5V), reading from the flexible disk is enabled.
WRITE DATA/	This line carries low active (OV) pulses representing data to be recorded on the flexible disk. Write current reverses direction on the leading edge of each pulse. Pulses must be 0.2 to 1.5 microseconds wide with a maximum repetition rate of 2.0 microseconds.
ABOVE TRACK 43/	This line is used to control write current amplitude guaranteeing IBM 3740 media interchangeability. This line must be high (5V) when recording on tracks 0 through 43, and low (OV) when recording on tracks 44 through 76. ABOVE TRACK 43/ must be stabilized 10 microseconds before activating WRITE ENABLE/.
PLO SYNC/*	A low level (OV) 12 microsecond wide pulse on this line will cause the PLL data separator to sync on preamble O's for data tracking.

*used with optional PLL data separator

OUTPUT SIGNALS

The following signals are output from the drive to the host controller:

READY/	A low level (0V) on this line indicates that the flexible disk is inserted correctly, DC voltages and disk speed are correct. This line is not gated by SELECT/ and is thus a unique line. This line serves as an interrupt to the controller.
INDEX/	The leading edge of a 4 ± 0.5 microsecond wide low (0V) pulse on this line represents the beginning of track. This pulse occurs once per revolution of the flexible disk.
TRACK 00/	When this line is low (0V) the read/write head is positioned over track 00. This line is intended as a head position reference. When this line is active stepper motor drive circuits are inhibited from further outward movement.
SECTOR/*	Low level (0V) pulses on this line represent sector marks. Sector pulses are 0.5 millisecond wide and the leading edge represents detection of sector holes punched in the flexible disk.
WRITE ENABLED/*	A low level (0V) on this line indicates that a write enable sticker is present on the flexible disk, thus writing may take place.

*optional

READ DATA This line transmits read data to the controller. Exact line definition and timing characteristics depend on the data separator used within the drive.

With No Data Separator

When no data separator is used, this line has no function.

With Standard One-Shot Separator

This line is a NRZ data line with the one shot separator. The level of the line represents data. A one bit is represented by a low (0V) level and a zero bit is represented by a high (5V) level. The READ CLOCK/ line is used to strobe data into the controller.

With Optional PLL Data Separator

This line outputs data pulses with the PLL separator. A one bit is represented by an 800 nanosecond low (0V) level pulse. A zero bit is represented by the absence of a pulse. The READ CLOCK/ line is used to strobe data into the controller.

READ CLOCK/

Exact meaning and timing characteristics of this line also depends on the data separator used within the drive.

With No Data Separator

When no data separator is used within the drive, this line outputs unseparated data (clocks and data). This output is provided for the systems designer who desires to use his own encoding scheme or provide data separation in the controller. This output may be used to enable detection of IBM 3740-type address marks by the controller. A modified one-shot decoder with a missing pulse detector will allow detection of 3740 address marks. Each flux reversal read from the disk is output as a 300 ± 100 nanosecond wide low (0V) pulse.

With One-Shot Separator

This line will output 1 ± 0.1 microsecond wide low (0V) pulses representing separated clocks. The trailing edge of these pulses is to be used to strobe the READ DATA line into the controller.

With PLL Separator

This line will output 800 nanosecond wide low (0V) pulses representing separated clocks. These pulses occur simultaneously with pulses occurring on the READ DATA line with this option.

INTERFACE CIRCUITS

Interface Signal Levels

Level	Minimum	Maximum	Nominal
High (false)	+2.40	+5.50	+3.00
Low (true)	-0.50	+0.40	+0.20

Receivers-Figure 12 depicts typical interface receivers. All receivers require termination resistors and are either "7404" TTL inverters or "836" DTL inverters. Controller drivers must be capable of sinking 25 milliamps in the low state.

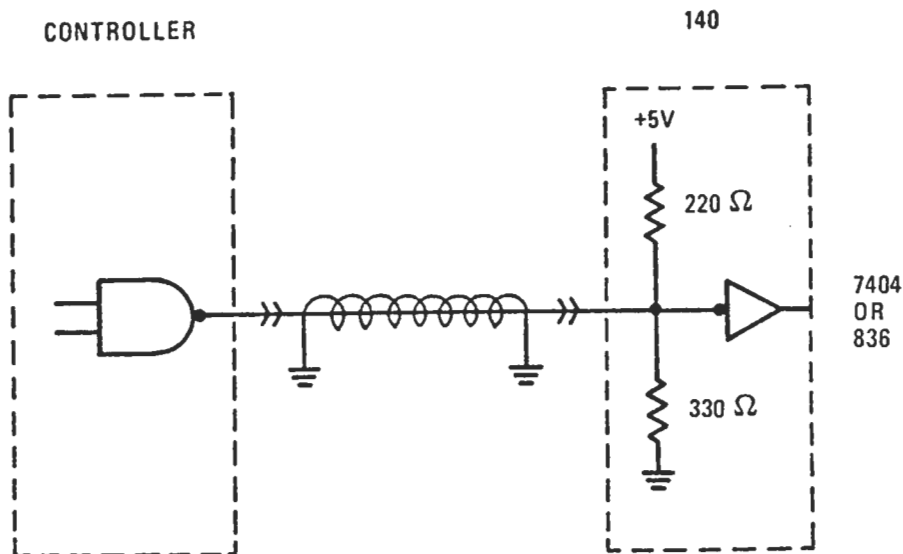

FIGURE 12. RECEIVER SCHEMATIC

Drivers-Figure 13 depicts typical interface drivers. All drivers are standard DTL "844" open collector power gates. Termination resistors are required at the controller. All driver outputs are high when the unit is not selected. These drivers sink 36 milliamps in the low state.

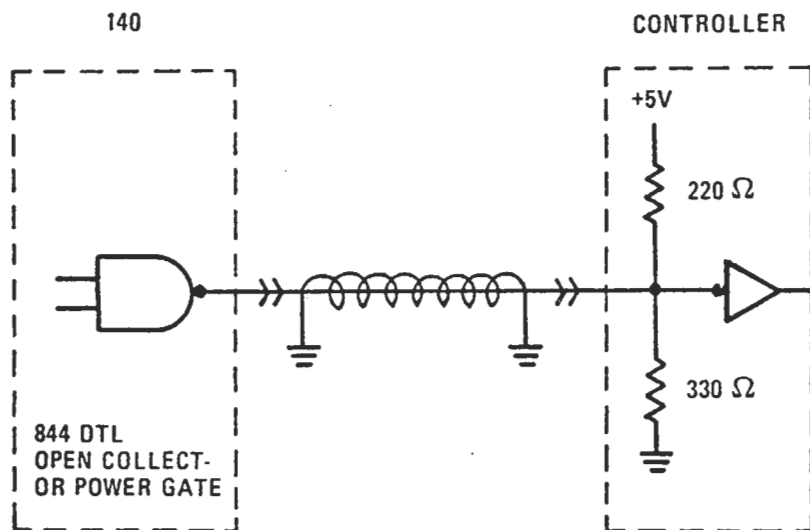

FIGURE 13. DRIVER SCHEMATIC

DC/Signal Cable Physical Wiring-A connector PWB is available (P/N 12084-XXX) for the CalComp 140 which may be used as part of necessary interface cabling between the drive and its controller. This connector PWB serves as an interconnection connector and also as a terminator in daisy chained configurations. In a daisy chained configuration termination resistors are present on the last drive's connector only. Figure 14 is a schematic representation of the PWB with termination resistors.

In a radial interface termination resistors are not needed unless cable length exceeds 5 feet.

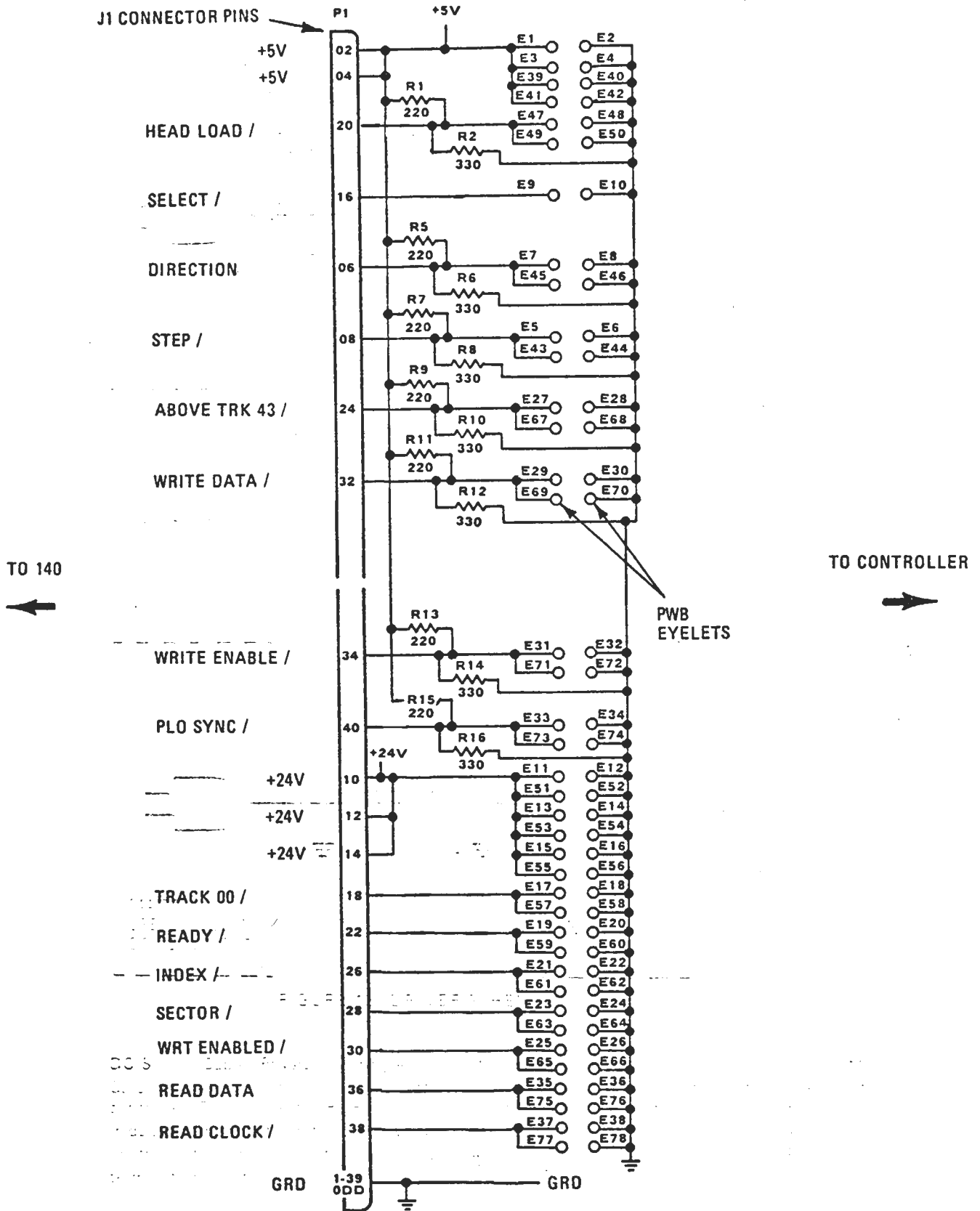

FIGURE 14. TERMINATOR SCHEMATIC

CONFIGURATIONS

The following information is provided to assist the systems designer in correct wiring of the connector in both daisy chained and radial configurations.

Daisy Chained Interface Wiring-All connector PWB eyelets **except the end drive** should be wired as described on page 26. Use terminator board P/N 12084-002.

Definitions:

- IN — a signal or power arriving at the drive's input interface.
- OUT — a signal being bussed to the next drive's input interface.
- UNIQUE — a signal not bussed.
- BUSS IN — a signal arriving at the drive or controller from the preceding drive (signals being bussed to the controller).
- BUSS OUT — a signal being sent from a drive towards the controller.

DAISY CHAIN WIRING (EXCEPT END DRIVE)

Use Terminator Board P/N 12084-002

E 1 +5V (IN)	E 2 TWP GND (E1)
E 3 +5V (IN)	E 4 TWP GND (E3)
E 5 STEP (IN)	E 6 TWP GND (E5)
E 7 DIRECTION (IN)	E 8 TWP GND (E7)
E 9 SELECT (IN, UNIQUE)	E10 TWP GND (E9)
E11 +24V (IN)	E12 TWP GND (E11)
E13 +24V (IN)	E14 TWP GND (E13)
E15 +24V (IN)	E16 TWP GND (E15)
E17 TRACK 00 (BUSS OUT)	E18 TWP GND (E17)
E19 READY (OUT, UNIQUE)	E20 TWP GND (E19)
E21 INDEX (BUSS OUT)	E22 TWP GND (E21)
E23 SECTOR (BUSS OUT)	E24 TWP GND (E23)
E25 WRITE ENABLED (BUSS OUT)	E26 TWP GND (E25)
E27 ABOVE TRK 43 (IN)	E28 TWP GND (E27)
E29 WRT DATA (IN)	E30 TWP GND (E29)
E31 WRT ENABLE (IN)	E32 TRP GND (E31)
E33 PLO SYNC (IN)	E34 TWP GND (E33)
E35 READ DATA (BUSS OUT)	E36 TWP GND (E35)
E37 READ CLOCK (BUSS OUT)	E38 TWP GND (E37)
E39 +5V (OUT)	E40 TWP GND (E39)
E41 +5V (OUT)	E42 TWP GND (E41)
E43 STEP (OUT)	E44 TWP GND (E43)
E45 DIRECTION (OUT)	E46 TWP GND (E45)
E47 HEAD LOAD (IN)	E48 TWP GND (E47)
E49 HEAD LOAD (OUT)	E50 TWP GND (E49)
E51 +24V (OUT)	E52 TWP GND (E51)
E53 +24V (OUT)	E54 TWP GND (E53)
E55 +24V (OUT)	E56 TWP GND (E55)
E57 TRACK 00 (BUSS IN)	E58 TWP GND (E57)
E59 NOT USED	E60 NOT USED
E61 INDEX (BUSS IN)	E62 TWP GND (E61)
E63 SECTOR (BUSS IN)	E64 TWP GND (E63)
E65 WRITE ENABLED (BUSS IN)	E66 TWP GND (E65)
E67 ABOVE TRK 43 (OUT)	E68 TWP GND (E67)
E69 WRT DATA (OUT)	E70 TWP GND (E69)
E71 WRT ENABLE (OUT)	E72 TWP GND (E71)
E73 PLO SYNC (OUT)	E74 TWP GND (E73)
E75 READ DATA (BUSS IN)	E76 TWP GND (E75)
E77 READ CLOCK (BUSS IN)	E78 TWP GND (E77)

End drive connector wiring (daisy chain). Use terminator board P/N 12084-001

E 1 +5V (IN)	E 2 TWP GND (E1)
E 3 +5V (IN)	E 4 TWP GND (E3)
E 5 STEP (IN)	E 6 TWP GND (E5)
E 7 DIRECTION (IN)	E 8 TWP GND (E7)
E 9 SELECT (IN, UNIQUE)	E10 TWP GND (E9)
E11 +24V (IN)	E12 TWP GND (E11)
E13 +24V (IN)	E14 TWP GND (E13)
E15 +24V (IN)	E16 TWP GND (E15)
E17 TRACK 00 (BUSS OUT)	E18 TWP GND (E17)
E19 READY (OUT, UNIQUE)	E20 TWP GND (E19)
E21 INDEX (BUSS OUT)	E22 TWP GND (E21)
E23 SECTOR (BUSS OUT)	E24 TWP GND (E23)
E25 WRITE ENABLED (BUSS OUT)	E26 TWP GND (E25)
E27 ABOVE TRK 43 (IN)	E28 TWP GND (E27)
E29 WRT DATA (IN)	E30 TWP GND (E29)
E31 WRT ENABLE (IN)	E32 TWP GND (E31)
E33 PLO SYNC (IN)	E34 TWP GND (E33)
E35 READ DATA (BUSS OUT)	E36 TWP GND (E35)
E37 READ CLOCK (BUSS OUT)	E38 TWP GND (E37)
E39	E40
E41	E42
E43	E44
E45	E46
E47 HEAD LOAD (IN)	E48 TWP GND (E47)
E49	E50
E51	E52
E53	E54
E55	E56
E57	E58
E59	E60
E61	E62
E63	E64
E65	E66
E67	E68
E69	E70
E71	E72
E73	E74
E75	E76
E77	E78

Radial Interface Wiring-The following are paddle board eyelet assignments when using the drive in a radial configuration. Use terminator board P/N 12084-001.

Definitions

IN – Signal or power coming from controller to drive.

OUT – Signal going from drive to controller.

E 1 +5V (IN)	E 2 TWP GND (E1)
E 3 +5V (IN)	E 4 TWP GND (E3)
E 5 STEP (IN)	E 6 TWP GND (E5)
E 7 DIRECTION (IN)	E 8 TWP GND (E7)
E 9 SELECT (IN)	E10 TWP GND (E9)
E11 +24V (IN)	E12 TWP GND (E11)
E13 +24V (IN)	E14 TWP GND (E13)
E15 +24V (IN)	E16 TWP GND (E15)
E17 TRACK 00 (OUT)	E18 TWP GND (E17)
E19 READY (OUT)	E20 TWP GND (E19)
E21 INDEX (OUT)	E22 TWP GND (E21)
E23 SECTOR (OUT)	E24 TWP GND (E23)
E25 WRITE ENABLED (OUT)	E26 TWP GND (E25)
E27 ABOVE TRK 43 (IN)	E28 TWP GND (E27)
E29 WRT DATA (IN)	E30 TWP GND (E29)
E31 WRT ENABLE (IN)	E32 TWP GND (E31)
E33 PLO SYNC (IN)	E34 TWP GND (E33)
E35 READ DATA (OUT)	E36 TWP GND (E35)
E37 READ CLOCK (OUT)	E38 TWP GND (E37)
E39	E40
E41	E42
E43	E44
E45	E46
E47 HEAD LOAD (IN)	E48 TWP GND (E47)
E49	E50
E51	E52
E53	E54
E55	E56
E57	E58
E59	E60
E61	E62
E63	E64
E65	E66
E67	E68
E69	E70
E71	E72
E73	E74
E75	E76
E77	E78

INTERFACE TIMING

Track Positioning

Track positioning is accomplished by using interface lines DIRECTION and STEP/. The DIRECTION line must be set to the proper level and be stable 100 nanoseconds minimum before the leading edge of STEP/. Figure 15 depicts track positioning timing requirements.

Head positioning is accomplished by pulsing the STEP/ line at 167 pulses per second with one resultant head position change per pulse. Ten milliseconds of head stabilization time must be provided for after the last step prior to proceeding with data transfer.

-NOTE-

The CalComp 140 is designed to operate at a step pulse rate of 167 pulses per second. Operation at slower step pulse rates may result in slightly noisy operation.

If a data transfer is to commence upon locating the desired track, it is recommended that the head be loaded by activating the HEAD LOAD/ line at the same time as issuing the last step pulse. Thus, the 16 millisecond time required to move the media against the head coincides with the time required for stepping the last track and mechanical stabilization of the head. By using this method only one time-out is required in the controller (16 milliseconds) and head loading is not a factor in latency.

Should an access position error occur, a reference may be established by either reading the track header or by stepping the head out until the TRACK 00/ line becomes active.

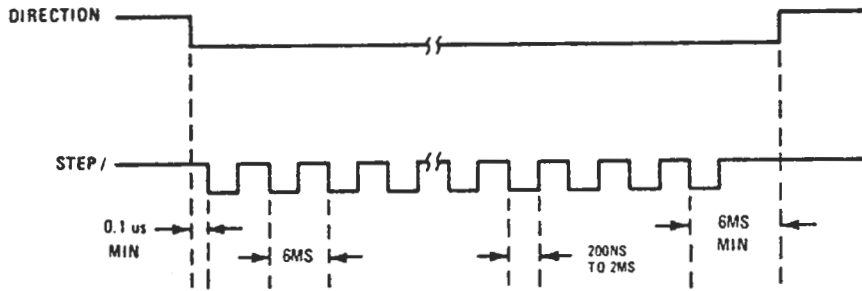

DIRECTION = OUT

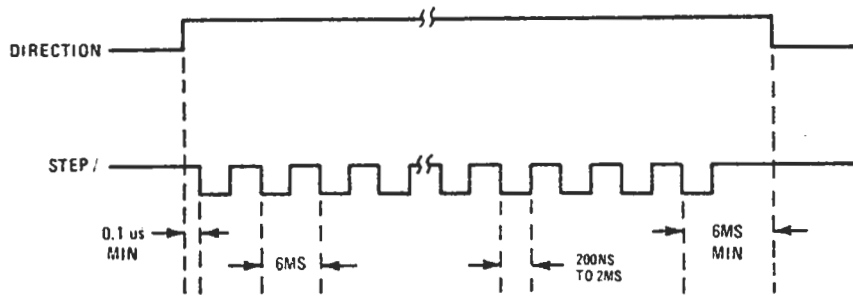

DIRECTION = IN

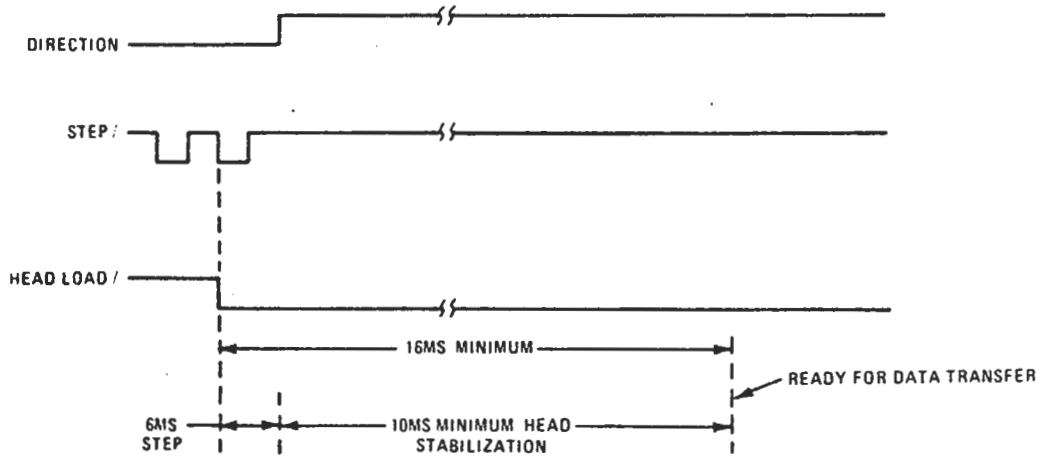

HEAD LOAD AND HEAD STABILIZATION

FIGURE 15. TRACK ACCESSING TIMING

Read Data Timing

Read data is transferred between the control unit and the CalComp 140 in a serial fashion. The organization of data and data storage capacity of the flexible disk are dependent upon the format used to record information.

A feature of the CalComp 140 is its universal read circuits. While the expected recording method is double frequency (FM), a systems designer may bypass the standard one-shot data separator and use the READ CLOCK/ output which would represent unseparated data and clocks to enable the use of another recording method which may be either more efficient or result in a higher throughput (see Figure 16).

For those applications which do not use the IBM 3740-type address marks, the standard one-shot data separator provides a READ CLOCK/ output which is used to strobe the status of the READ DATA line into the controller. Thus, READ CLOCK/ becomes separated clock and READ DATA becomes separated data (see Figure 17).

For the systems designer who desires IBM media compatibility, an optional PLL Data Separator option is offered. This circuit ensures the highest data integrity in addition to its ability to enable detection of missing clocks as used with IBM 3740 address marks. The circuit is designed so that both data and clock outputs coincide. During reading of an address mark, the PLL remains in sync during the bit cell time in which the missing clock is absent. READ DATA active with READ CLOCK/ being false signifies that a byte is being read in which a clock pulse is missing. The systems designer simply has to decode the data pattern of that associated byte to determine which type of address mark has been read (see Figure 18).

For clarity each of the read data outputs is depicted separately along with appropriate timing details (see Figures 16, 17 and 18).

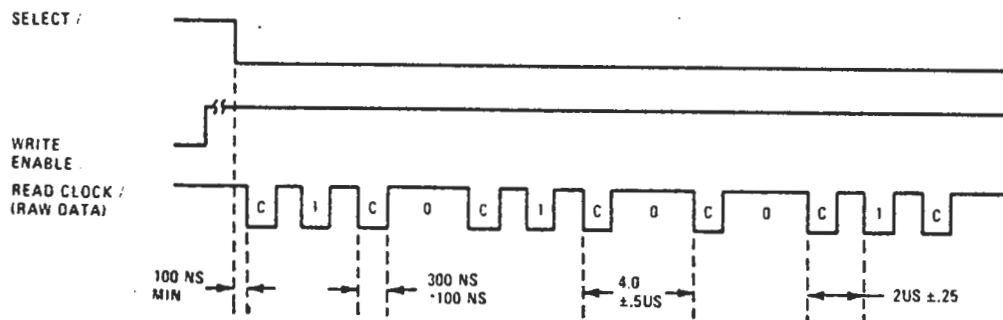

FIGURE 16. RAW DATA TIMING

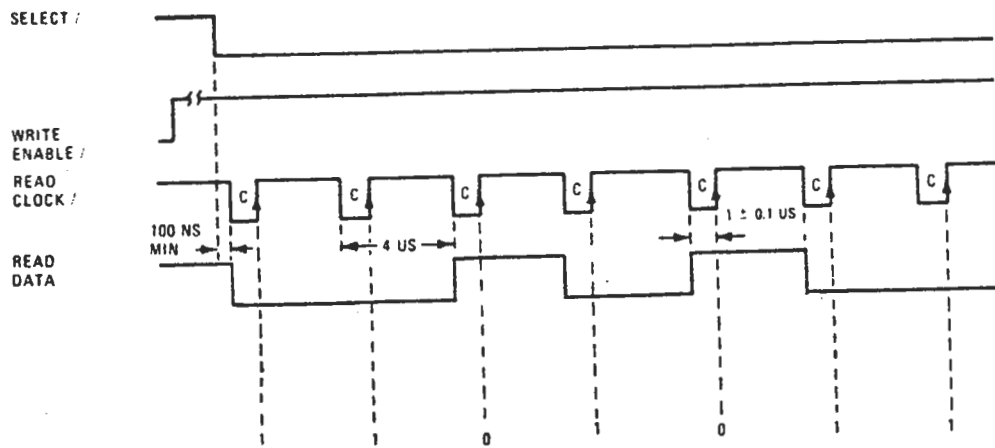

FIGURE 17. ONE-SHOT TIMING

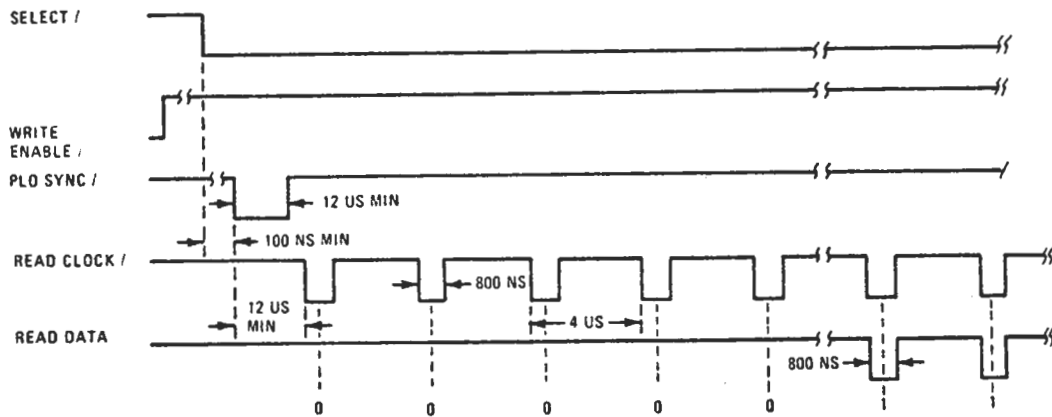

FIGURE 18. PLL TIMING

Write Data Timing

Write data is transferred between the control unit and the CalComp 140 in a serial fashion. The interface line WRITE ENABLE/ controls both erase and write amplifiers. The erase amplifier is enabled at the leading edge of WRITE ENABLE/ and is disabled 600 nominal microseconds after the fall of WRITE ENABLE/. This delay is provided to ensure final trimming of the just-written data. See Figure 19 for write timing requirements.

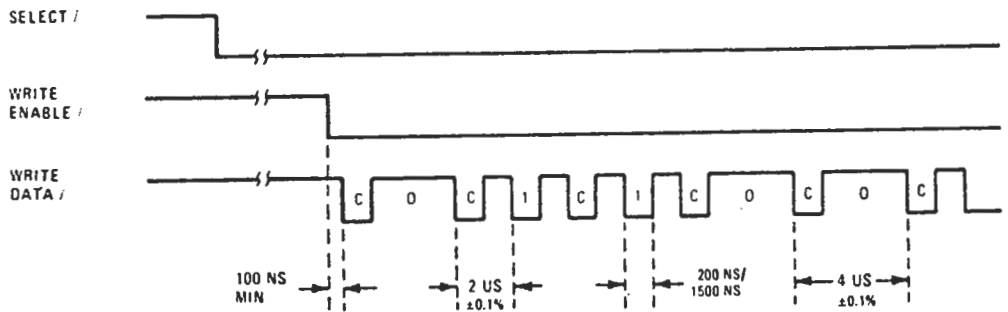

FIGURE 19. WRITE DATA TIMING

Index/Sector Timing

Figure 20 depicts index and sector pulse timing. Sector outputs are generated from up to 32 additional holes punched in the flexible disk. Index and sector pulses are separated by the drive's electronics and output on interface lines SECTOR/ and INDEX/.

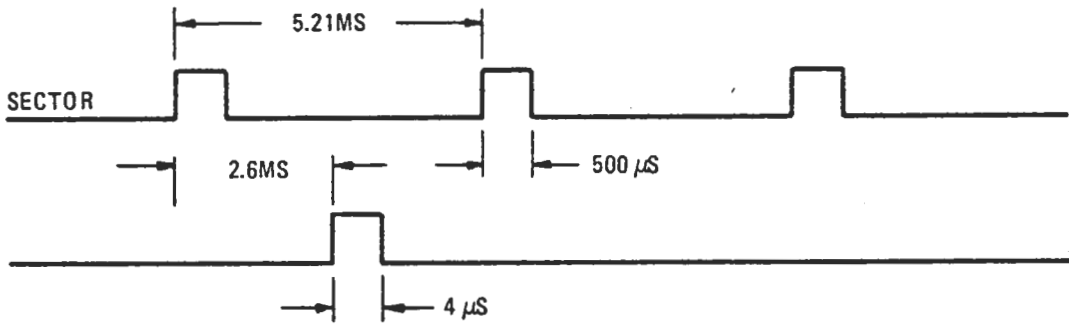

FIGURE 20. INDEX/SECTOR TIMING

Power-On To Data Transfer

Figures 21 and 22 are provided as a reference for power-on to data transfer. Power-on to read timing is depicted by Figure 21 and power-on to write timing is depicted by Figure 22.

In both cases it is assumed that the controller will step the head to track 00 for a reference prior to stepping to a specified track. It is not necessary to have a cartridge loaded to step the read/write head. For explanation purposes, it is assumed that a cartridge is loaded and the controller will wait for the READY/ interrupt prior to causing head stepping.

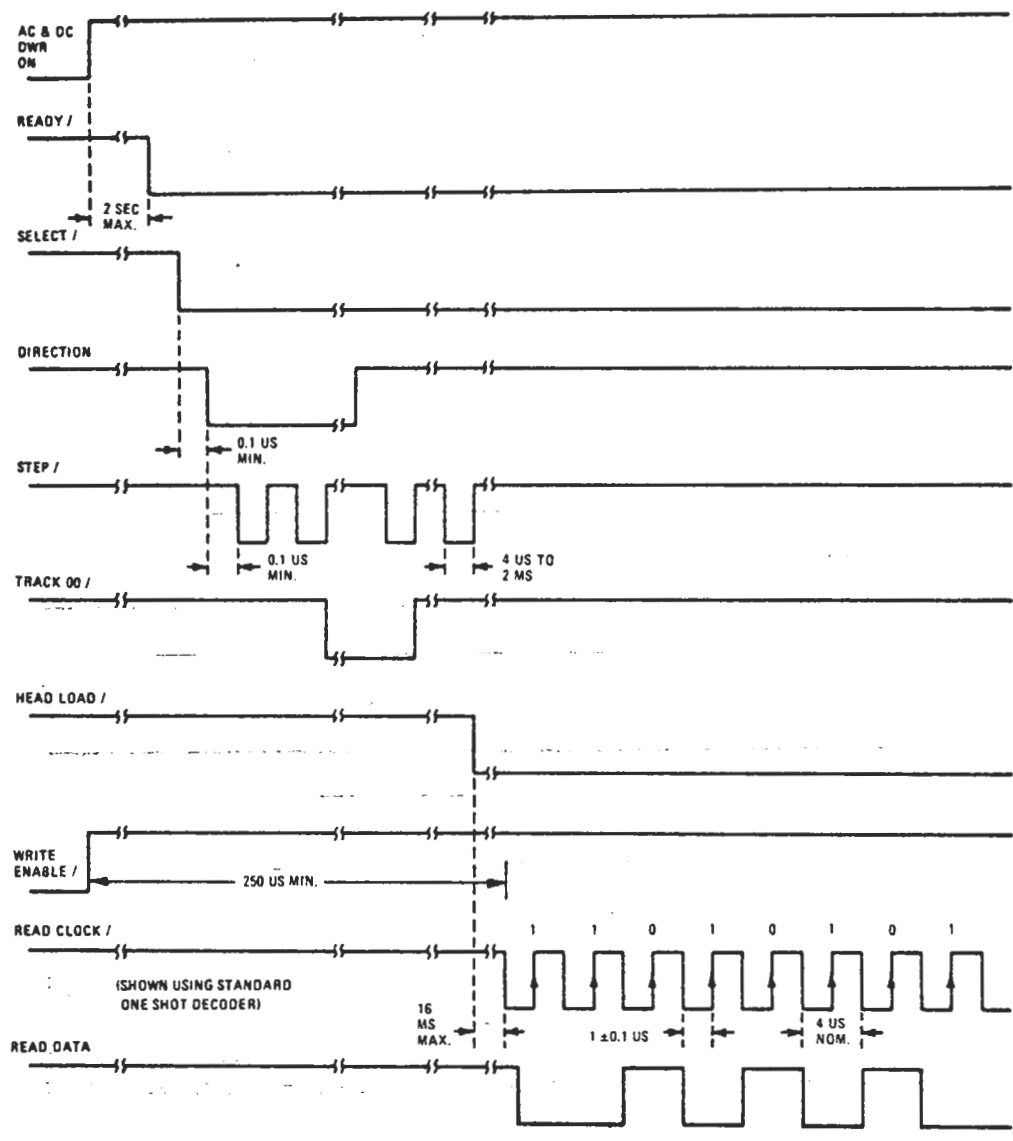

FIGURE 21. POWER-ON TO READ TIMING

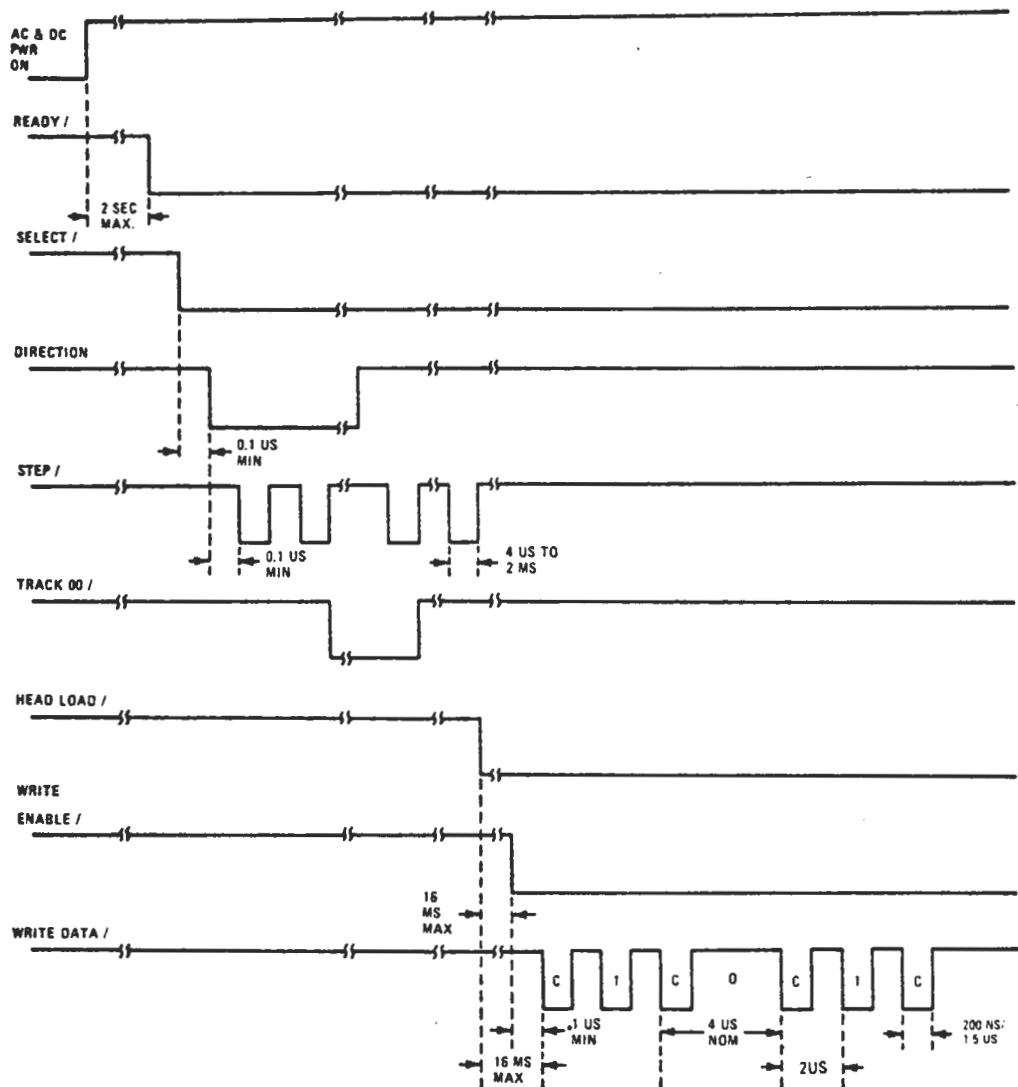

FIGURE 22. POWER-ON TO WRITE TIMING

DATA SEPARATOR OPTION WIRING

The CalComp 140 is normally shipped with the data separator jumper socket blank. The jumper socket is located on the electronics PWB at position A6 (see Figure 23).

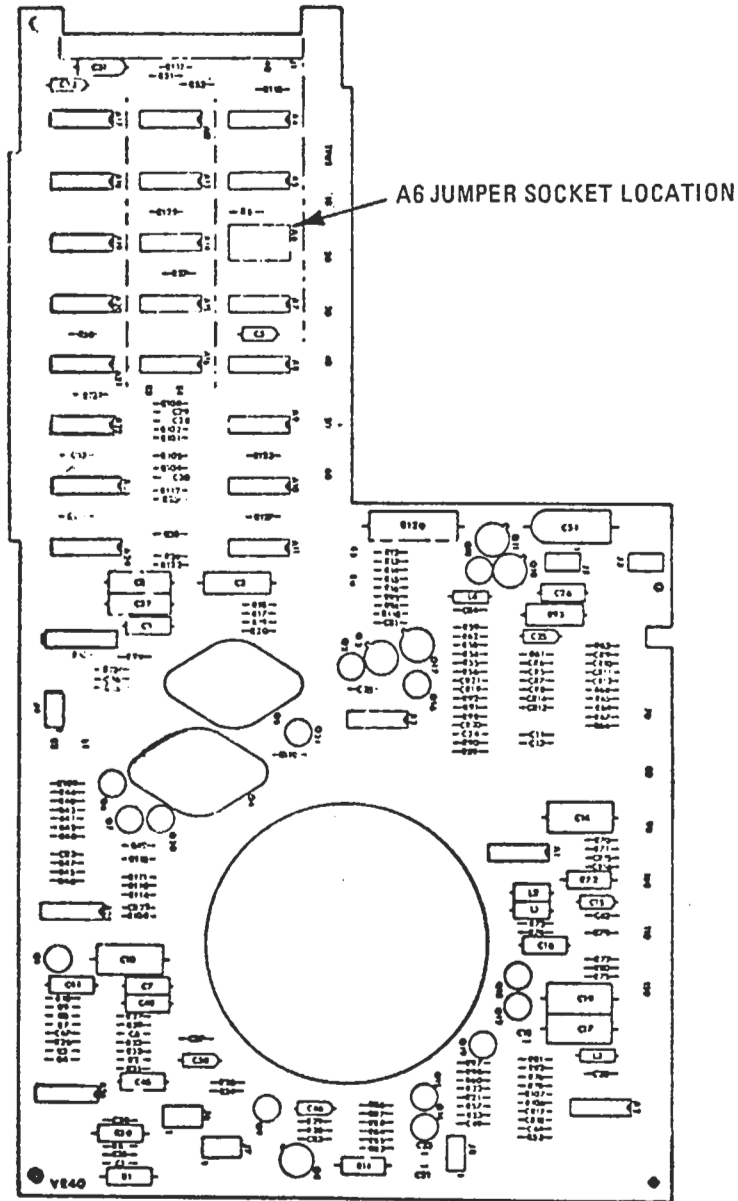
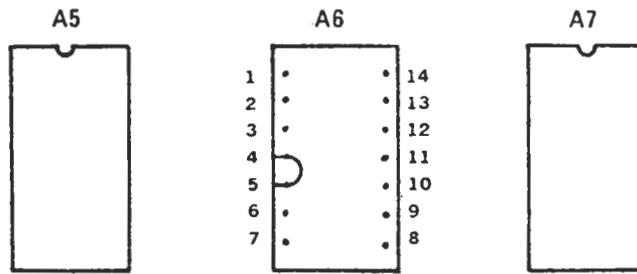

FIGURE 23. DATA SEPARATOR JUMPER SOCKET LOCATION

Raw Data Output



Jumper A6-4 to A6-5
Raw data output is J1-38 (READ CLOCK/)

One-Shot Output

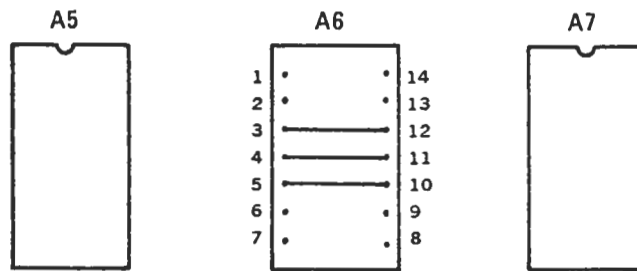

Jumper A6-3 to A6-12
A6-4 to A6-11
A6-5 to A6-10
Separated data output is J1-36 (READ DATA)
Separated Clock output is J1-38 (READ CLOCK/)

PHYSICAL DIMENSIONS

The dimensions of the CalComp 140 are 8.4 inches wide, 15.75 inches deep, and 4.9 inches high as depicted by Figure 24. These dimensions provide the capability of mounting two units horizontally or three units vertically in a standard 19 inch RETMA rack. A clearance of three inches should be provided at the rear of the unit to accommodate cabling and air flow. Also depicted are chassis slide mounting hole locations.

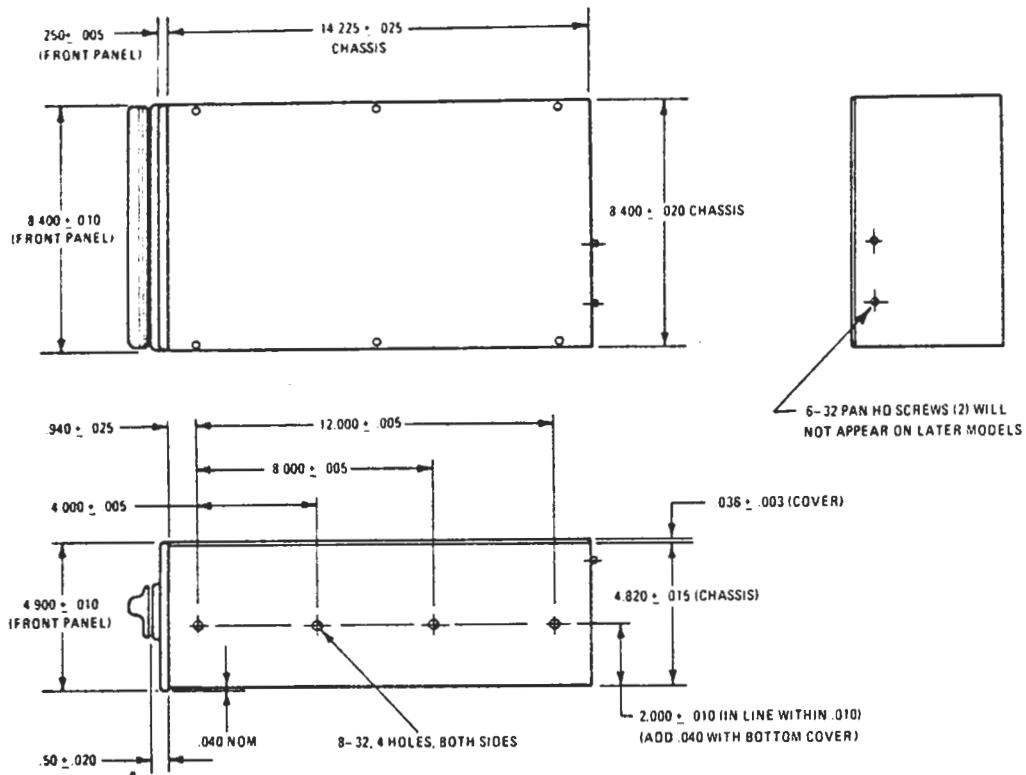

FIGURE 24. PHYSICAL DIMENSIONS

ACCESSORIES

The following accessories are available for use with the CalComp 140:

P/N 12067-001	Model 2140 Disk Drive Exerciser
P/N 12084-001	Assy, PWB Cable Terminator (End Drive Daisy Chain)
P/N 12084-002	Assy, PWB Cable Terminator (Interconnection)
P/N 12634-001	Shipping Container, Model 140 Disk Drive
P/N 12887-001	Head/Index Transducer Alignment Tool

OPERATING PROCEDURES

The CalComp 140 is designed for ease of operation in a variety of applications. The following procedures are intended to familiarize operator personnel with operation of the unit.

Flexible Disk Handling

The storage element is a flexible disk enclosed within a plastic envelope. A protective jacket is provided with each flexible disk to be used whenever the flexible disk is not in use.

As the flexible disk is made from similar material as computer magnetic tape, the same guidelines apply. The following precautions will ensure long life and reliable operation.

- Remove the flexible disk from its protective jacket only when preparing for use.
- As strong magnetic fields may destroy data, keep flexible disks away from magnetic fields and ferromagnetic materials.
- Replace protective jackets if they become worn, cracked or distorted.
- Use only a felt-tipped pen to record information on the protective jacket.
- Do not write on the flexible disk envelope. Prepare a sticket with appropriate information and then apply to the envelope.
- Do not allow foreign debris to fall on the flexible disk as disk and head contamination can occur.
- Do not expose flexible disk to heat or direct sunlight.
- Do not touch or attempt to clean exposed flexible disk surface.

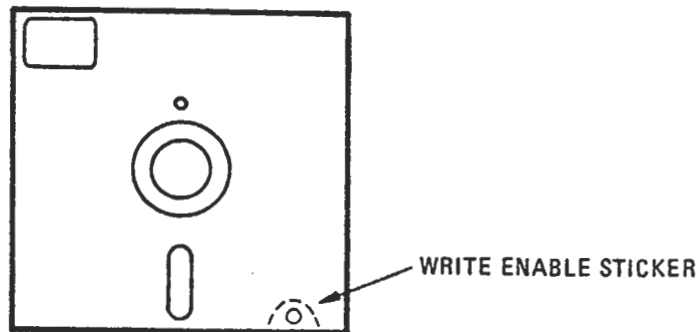

FIGURE 25. WRITE PROTECT OPTION

Write Protect Option

The write protect option is offered as a means of protecting against inadvertent destruction of data. The write protect option includes a phototransistor which senses the presence or absence of a sticker affixed to the flexible disk (see Figure 26).

With this option any disk lacking the reflective sticker is "write protected", meaning the drive cannot record data on the disk. Thus, this option is designed to be fail safe, i.e., should a sticker be inadvertently removed, the flexible disk is automatically protected. This option operates as a "write enable" ring on a large tape drive. The "write enable" ring must be present to write. The flexible disk must contain a "write enable" sticker to write.

Flexible Disk Loading

To load the flexible disk simply depress the pushbutton located on the center of the front plate. The front plate is spring-loaded and will then open automatically.

Insert the flexible disk into the load aperture with the label closest to the operator and facing the opened front plate (see Figure 26). Ensure the flexible disk is positioned fully within the drive.

Grasp the bar on the front plate and close firmly. The front plate will mechanically lock shut.

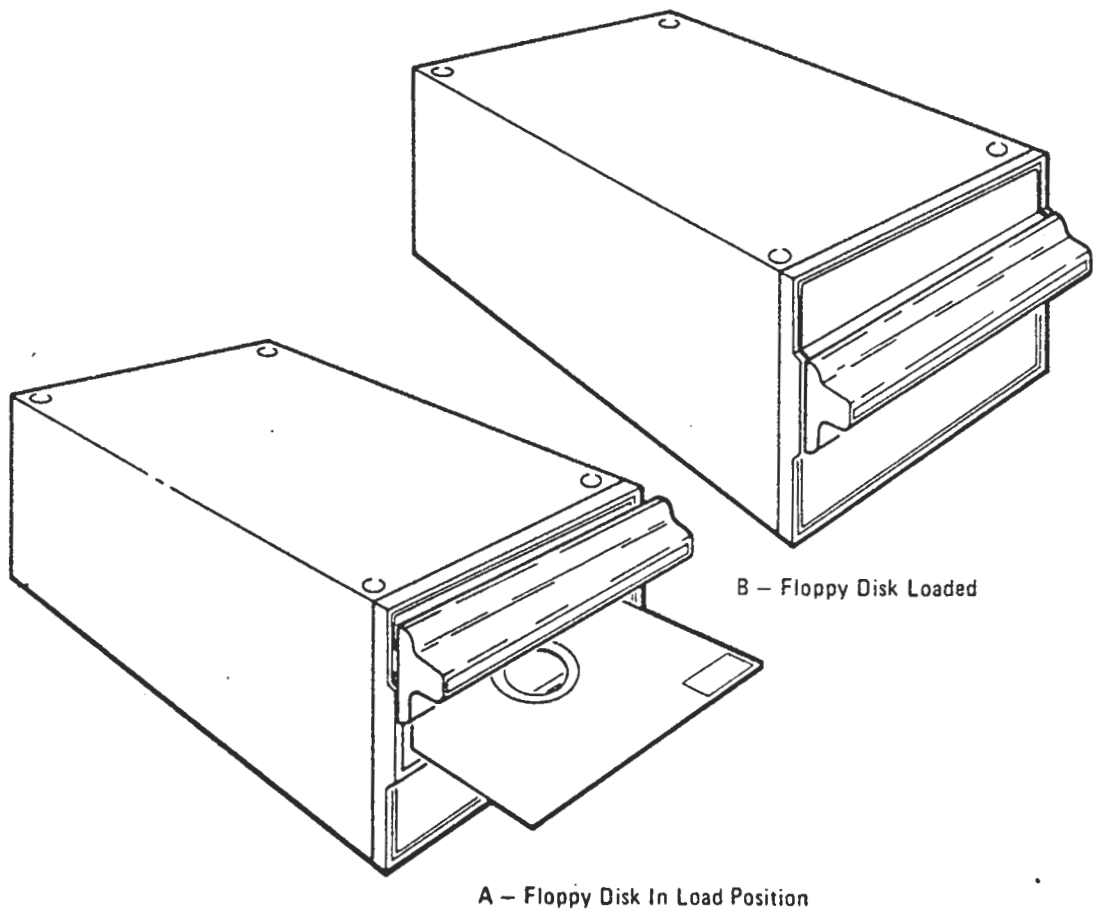

FIGURE 26. FLEXIBLE DISK LOADING

March, 1976

MODEL 140 FLOPPY DISK DRIVE

INSTALLATION INSTRUCTIONS

1. Inspect the unit for exterior shipping damage. Unpack-
age unit using care not to damage the handle mechanism
by lifting the drive by the handle. Inspect for visible
damage.
2. Any hardware shipped with the unit will be found in the
cavity in the rear of the unit. Check shipping paperwork
against items received. Notify CalComp of any discrepancies.
3. Check PWB connectors for proper seating.
4. Do not run the unit for extended periods of time without
covers.
5. The units have a jumper plug (A6) which comes configured
for raw data or one-shot data according to the following:

11700-01X }
-03X } one-shot data

11700-00X }
-02X }
-04X } raw data
-05X }
14700-XXX }

6. CalComp recommends IBM or ITC media. Customers desiring
to use other media should contact CalComp prior to such
usage to avoid drive/media problems.



Peter Grohmann
Sr. Applications Engineer

HEAD LOAD DRIVER

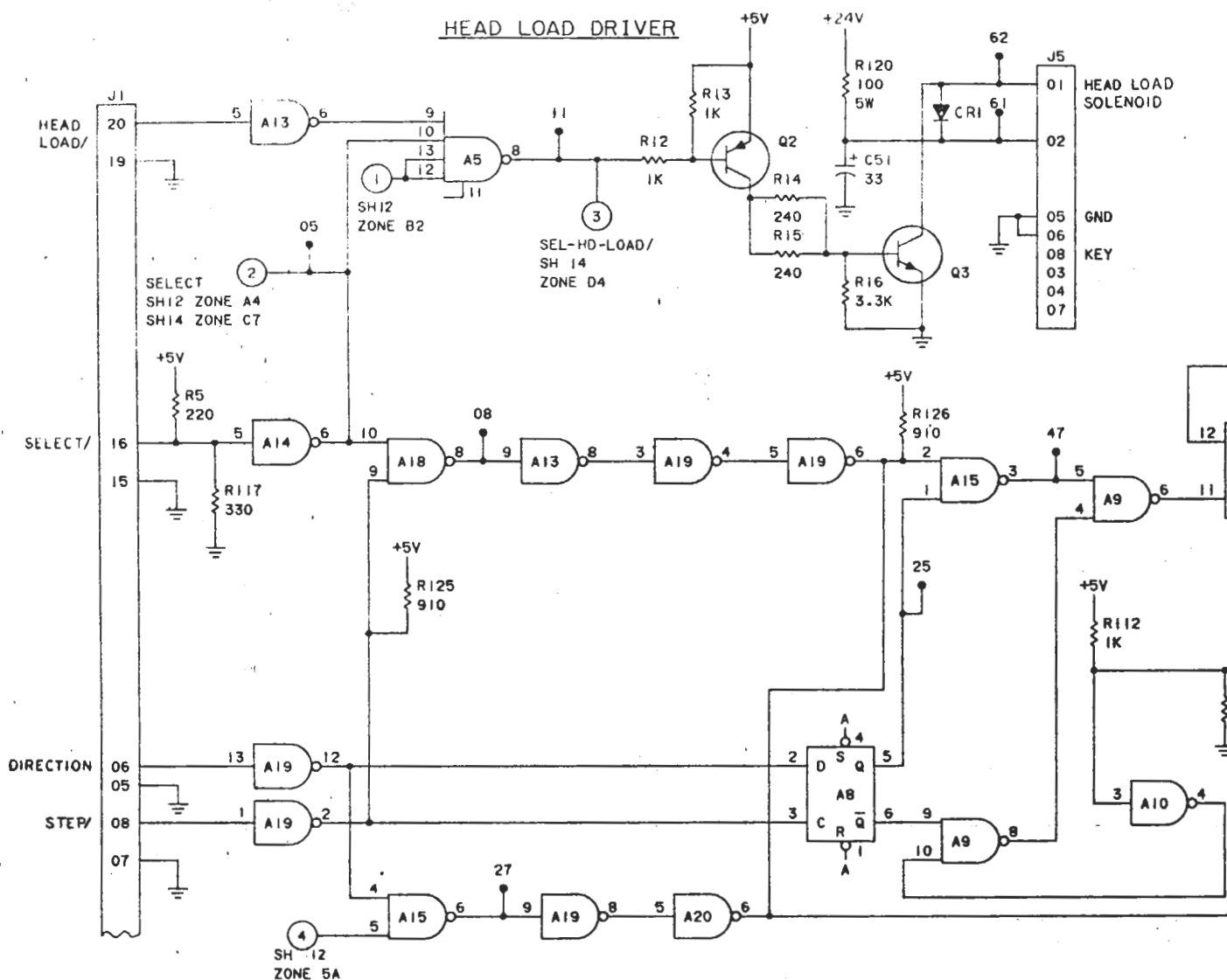

5. REV LEVEL OF THIS PART IS NOTED ON DWGS 14618, 14619, 14620 & 14701.
 4. TEST POINTS ARE THE ETCHED CONNECTOR FINGERS ON THE EDGE OF BOARD
 3. CAPACITANCE VALUES ARE IN MICROFARADS
 2. ALL 1% RESISTORS ARE 1/8W
 1. RESISTANCE VALUES ARE IN OHMS, 1/4W, 5%
- NOTE: UNLESS OTHERWISE SPECIFIED

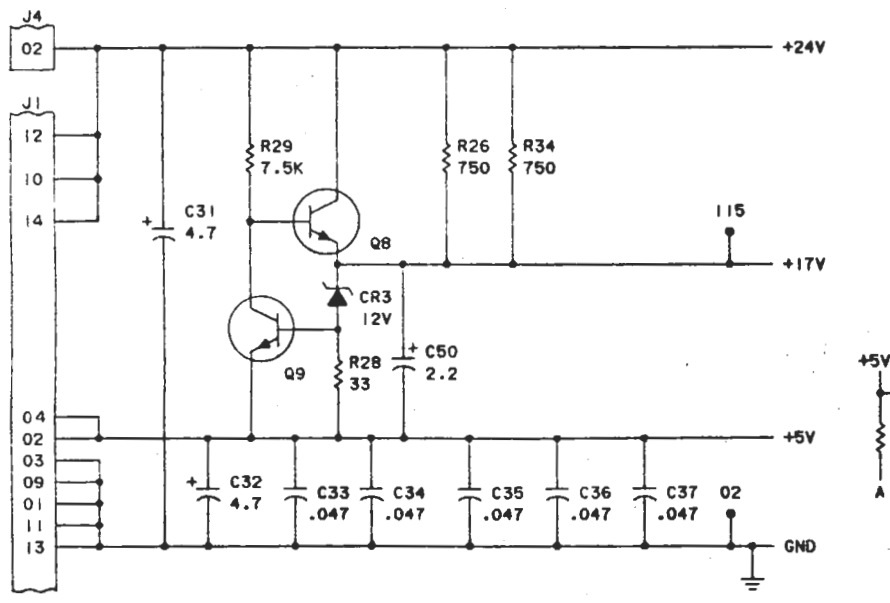

STEPPER MOTOR DRIVE

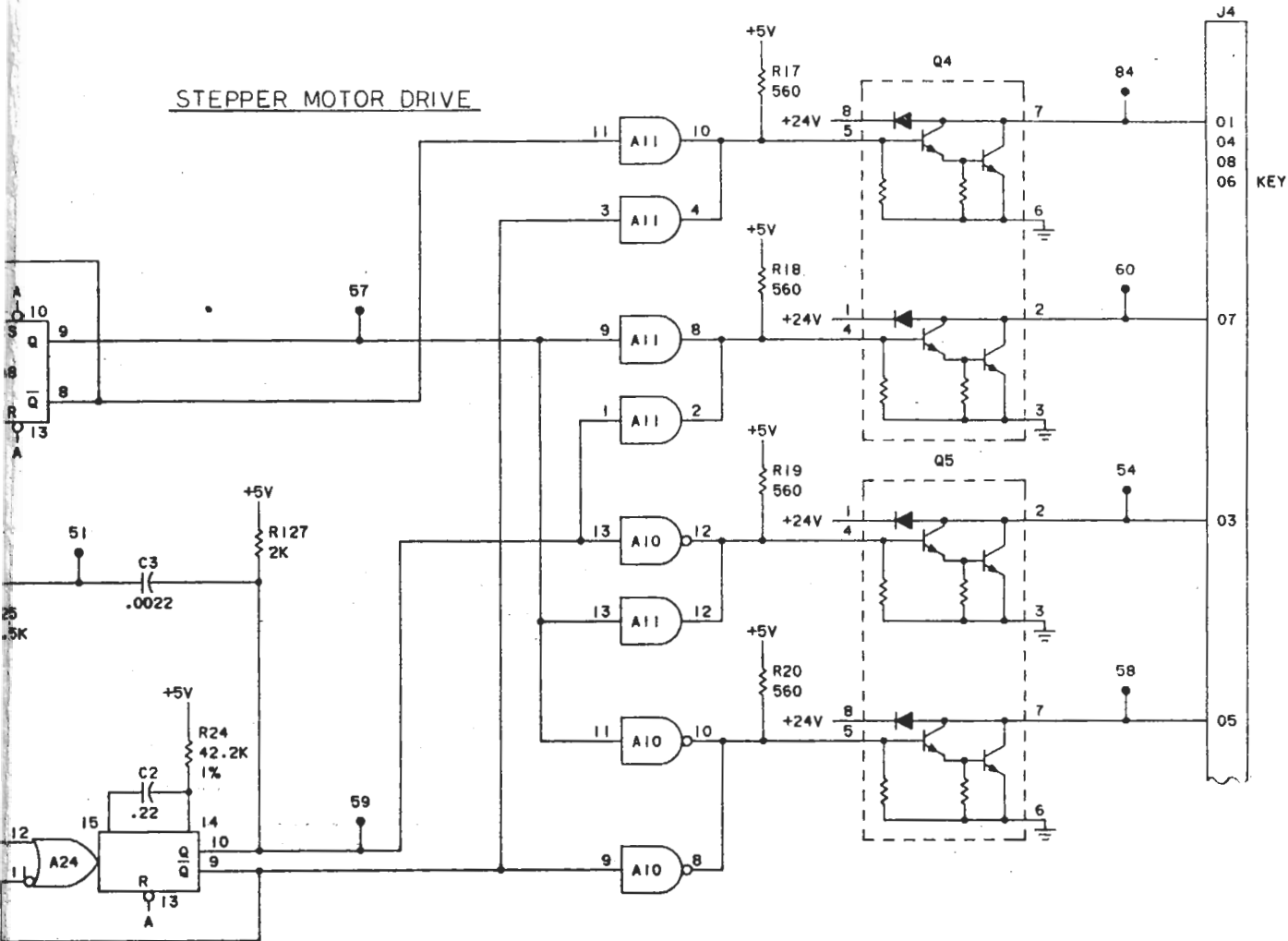

D
C
B
A

SPARES

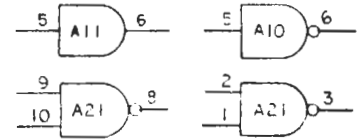

INTEGRATED CIRCUIT VOLTAGE CHART			
VOLTAGE	PIN NO.	I.C.	REF DES
+5	14	A3, A4, A5, A7-A22	
+5	16	A23, A24	
GND	7	A3, A4, A5, A7-A22	
GND	8	A23, A24	

REF DES	REF DES	REF DES	REF DES
LAST USED	NOT USED	NOT USED	NOT USED
R129	A26	C38	C39
C52	J8	C40	C12
Q21		C22	C4
CR22		C43	R69
L4		J2	C48
		C47	
		C9	

Century Data SYSTEMS, INC. ANAHEIM, CALIFORNIA

ASSY, PWB-DATA AND CONTROL (SCHEMATIC) VR49

DRAWN	J. HOFFMAN	2-2-4	SIZE		REV	M
CHECK			D	13921-001		
APPD						

SCALE: NONE SHEET 10 OF 13

REV M
DWG NO 13921-001

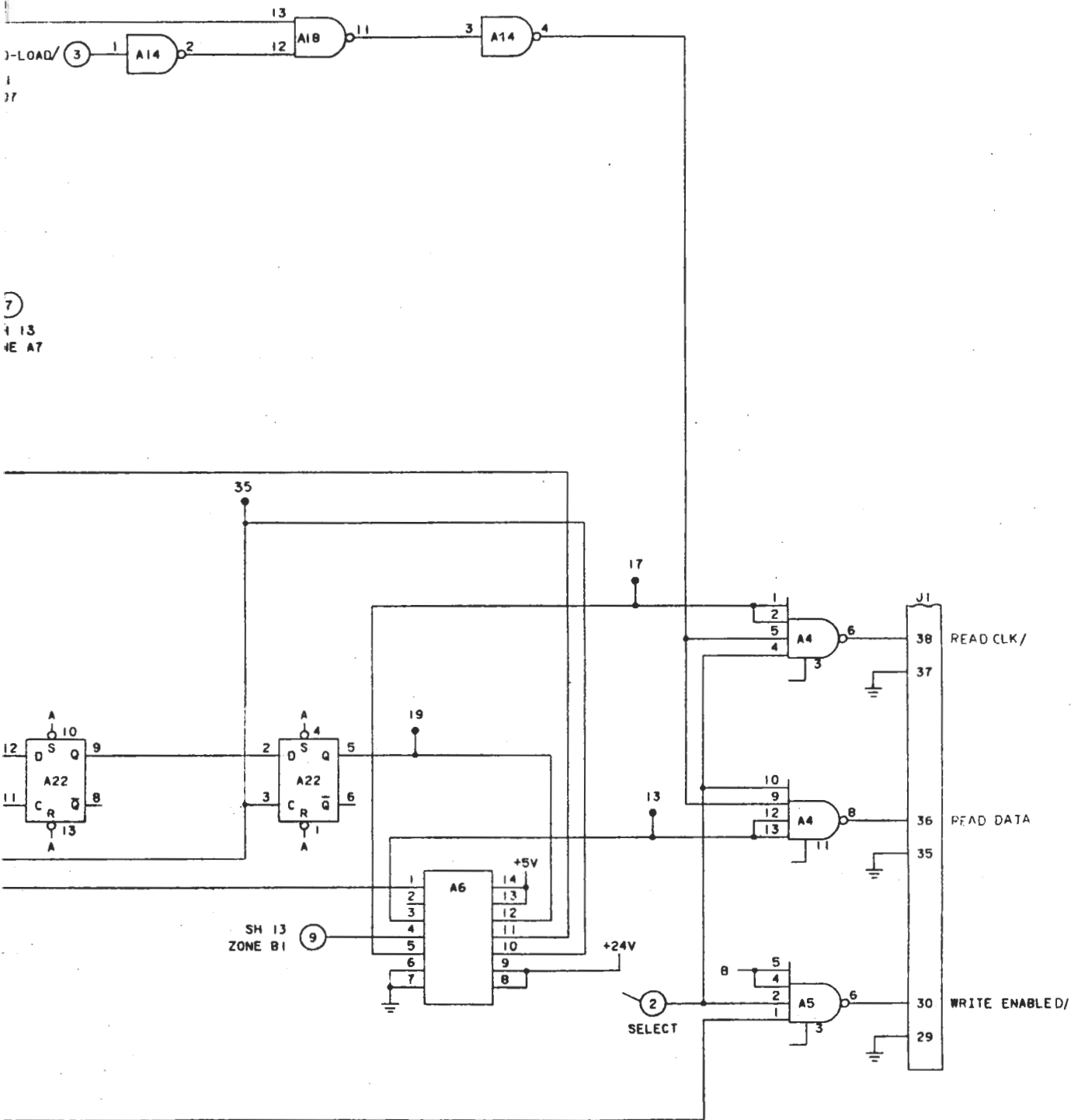

LOAD/ 3
1
37

7
13
E A7

SH 13
ZONE B1 9

SELECT 2

D

C

B

A

		CENTURY DATA SYSTEMS, INC. ARABIAN, CALIFORNIA	
ASSY, PWB-DATA AND CONTROL (SCHEMATIC)			VR49
DRAWN	J HOFFMAN	2-2-4	SIZE
CHECK	<i>[Signature]</i>		D
APPD	<i>[Signature]</i>		13-21-001
SCALE: NONE		SHEET 13 OF 13	
		REV M	

REV M
DWG NO. 13-21-001

↑

4 3 2 1

READ PRE-AMPLIFIER

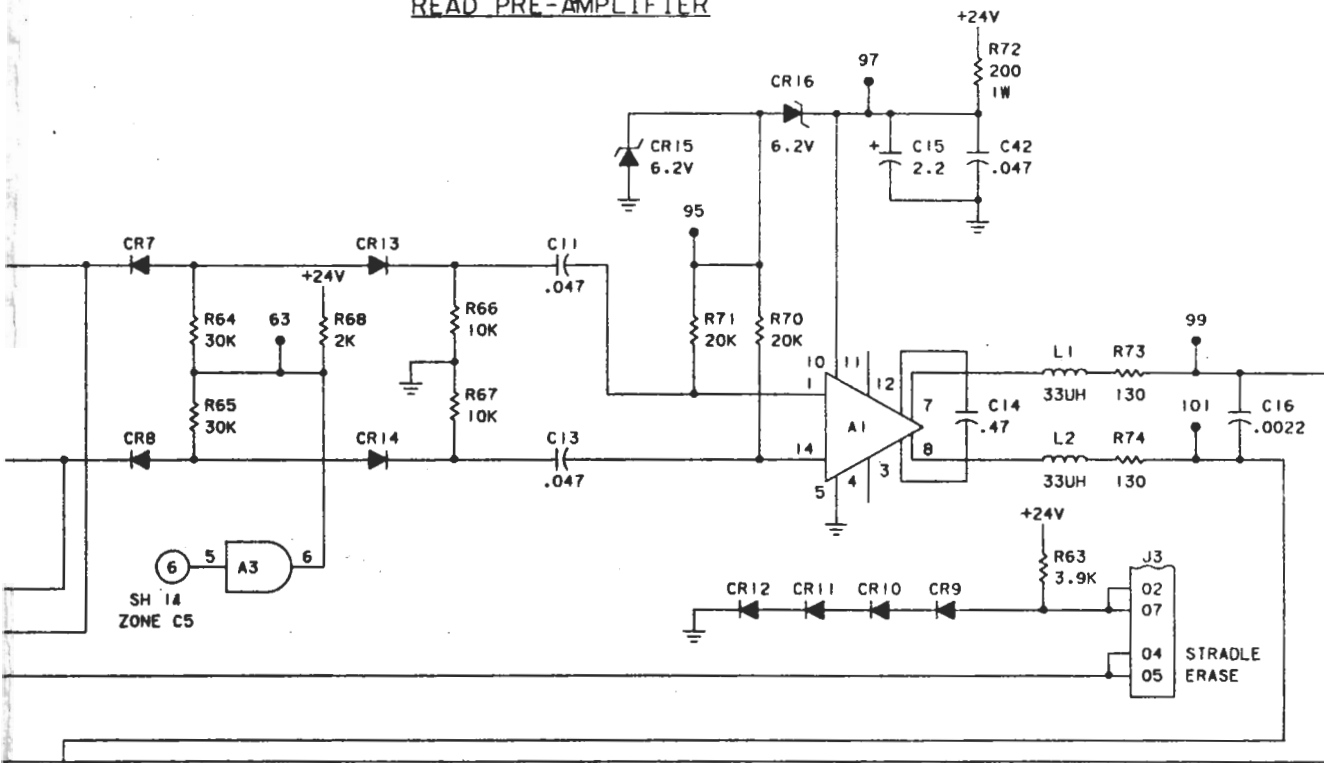

PEAK DETECTOR

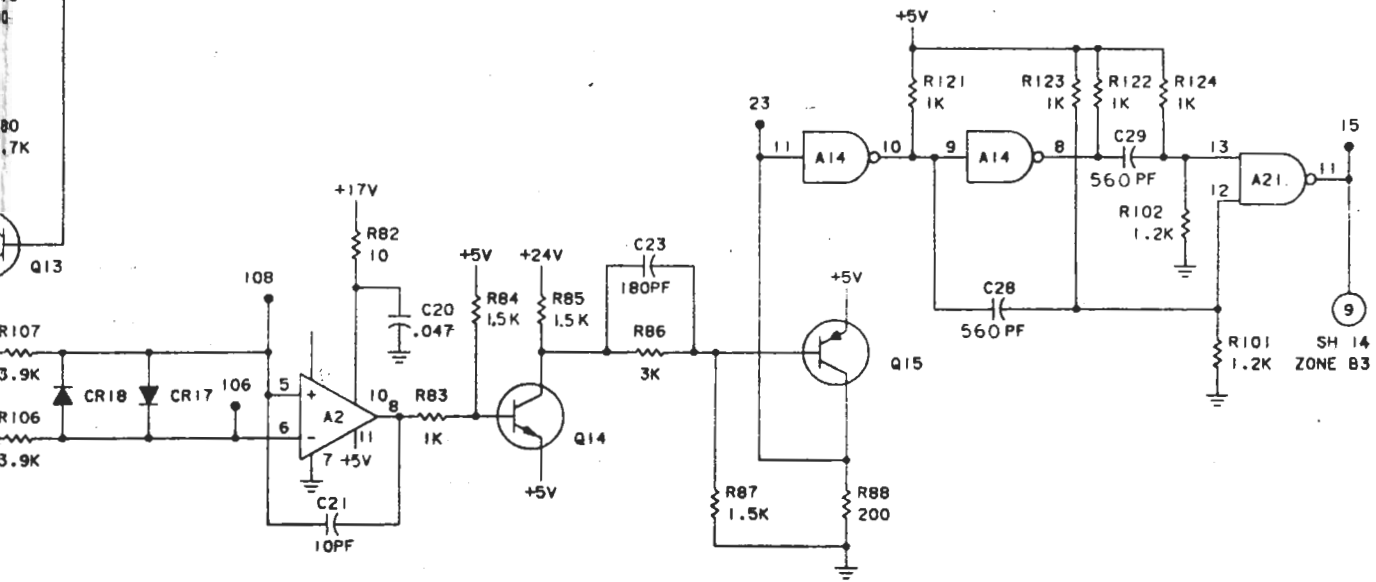

Century Data SYSTEMS, INC. ANAHEIM, CALIFORNIA

ASSY. PWB-DATA AND CONTROL (SCHEMATIC) VR49

DRAWN	J. HOFFMAN	2-2-4	SIZE	D	13421-001	REV	M
CHECK	<i>[Signature]</i>	6/21/76					
APPD	<i>[Signature]</i>	5-20-76					
SCALE: NONE				SHEET 12 OF 13			

D

C

B

A

REV. M

DWG. NO. 13421-001

INDEX AMPLIFIER

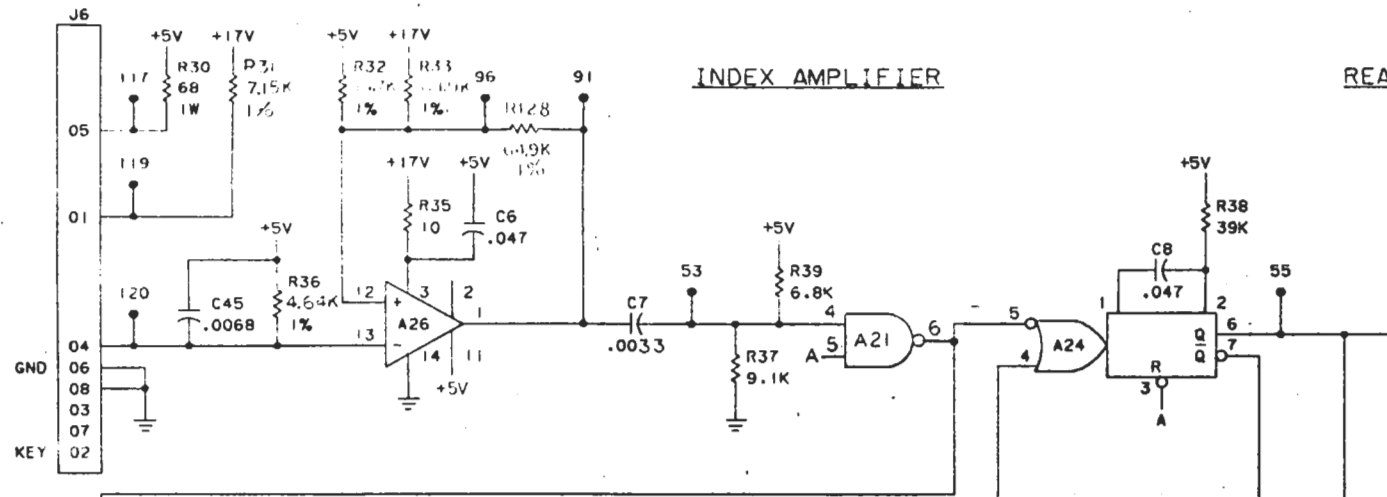

D

C

→

B

TRACK 00 AMP

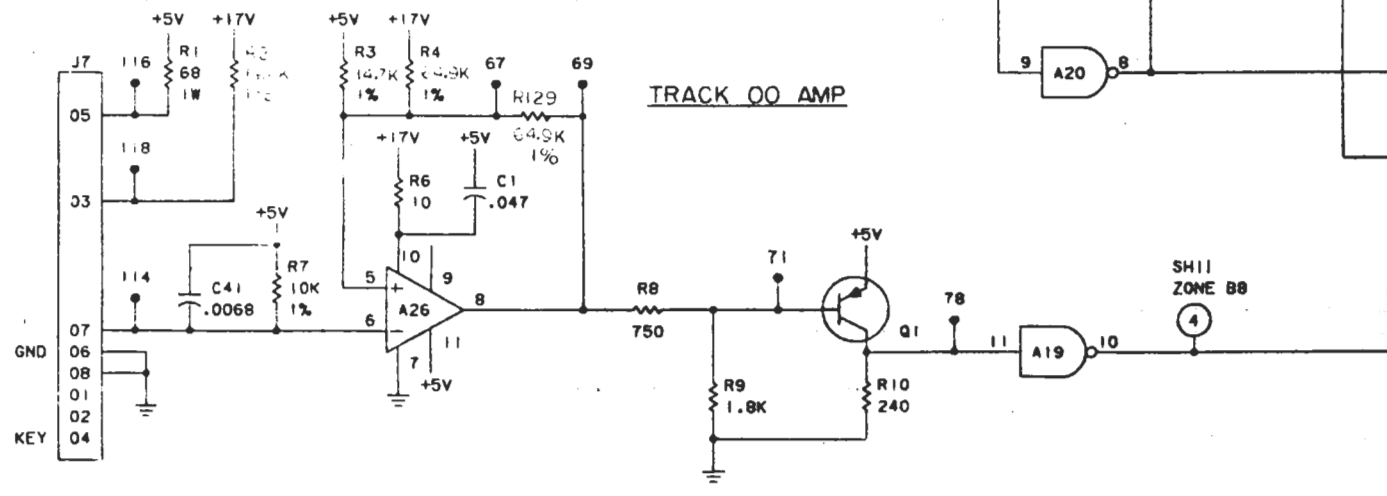

A

Y CIRCUIT

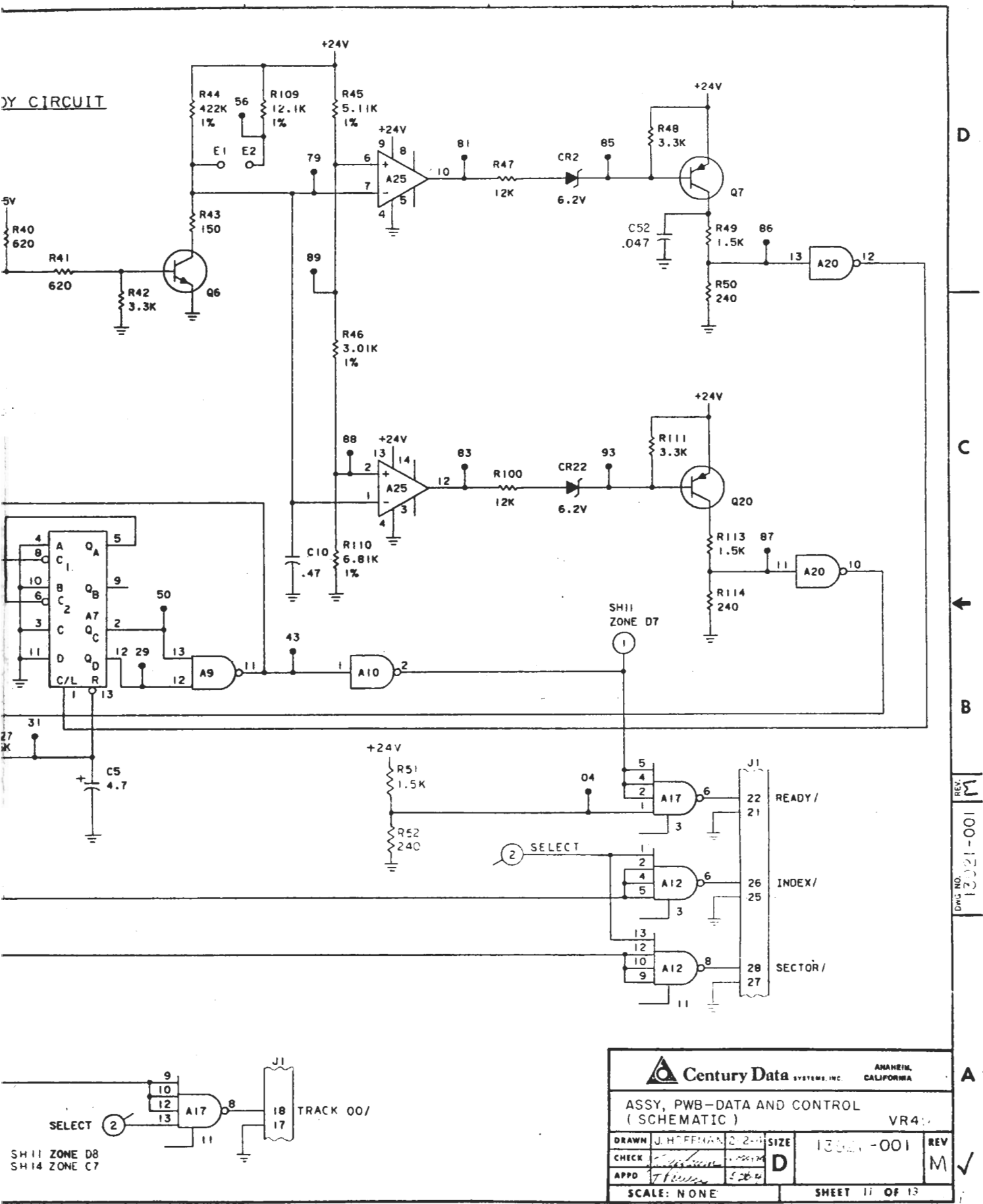

D
 C
 B
 REV M
 100-1721-001
 DWG NO.

Century Data SYSTEMS, INC. ANAHEIM, CALIFORNIA		VR4
ASSY, PWB-DATA AND CONTROL (SCHEMATIC)		
DRAWN J. HOFFMAN 2-2-74	SIZE 100-1721-001	REV M
CHECK <i>[Signature]</i>	APPD <i>[Signature]</i>	SHEET 11 OF 13
SCALE: NONE		

SH11 ZONE D8
SH14 ZONE C7