



Figure 1-1

# ALTAIR 8800b COMPUTER

# altair 8800b

## DOCUMENTATION

© MITS, Inc. 1976  
Reprinted, June, 1977



**mits**

a subsidiary of **Pertec Computer Corporation**  
2450 Alamo S.E. /Albuquerque, New Mexico 87106

ALTAIR 8800b  
TABLE OF CONTENTS

| Section  | Page |
|--|------|
| LIST OF TABLES . . . . .   | ii   |
| LIST OF ILLUSTRATIONS . . . . .                                    | iii  |
| <br>I. INTRODUCTION  |      |
| 1-1. Scope . . . . .   | 1-1  |
| 1-2. Arrangement . . . . .   | 1-1  |
| 1-3. Description . . . . .   | 1-1  |
| <br>II. OPERATORS GUIDE  |      |
| 2-1. General . . . . .   | 2-1  |
| 2-2. Front Panel Switches and Indicators . . . . .                 | 2-1  |
| 2-12. Loading A Sample Program . . . . .                           | 2-11 |
| 2-14. Intel 8080 Microcomputer System User's Information . . . . . | 2-15 |
| <br>III. THEORY OF OPERATION                                       |      |
| 3-1. General . . . . .   | 3-3  |
| 3-2. Logic Circuits . . . . .                                      | 3-3  |
| 3-3. Intel 8080 Microcomputer System User's Information . . . . .  | 3-8  |
| 3-5. 8080b Block Diagram Description . . . . .                     | 3-39 |
| 3-11. 8800b Data Processing Operation . . . . .                    | 3-44 |
| 3-12. Instruction Fetch Cycle . . . . .                            | 3-44 |
| 3-15. Memory Read Cycle . . . . .                                  | 3-49 |
| 3-18. External Device to CPU Data Transfer . . . . .               | 3-54 |
| 3-21. CPU to Memory Data Transfer . . . . .                        | 3-59 |
| 3-23. Memory Write Cycle Detailed Operation . . . . .              | 3-61 |
| 3-24. Memory to CPU Data Transfer . . . . .                        | 3-63 |
| 3-25. CPU To External Device Data Transfer . . . . .               | 3-64 |
| 3-28. Front Panel Operation . . . . .                              | 3-68 |
| 3-39. 8800b Options . . . . .                                      | 3-88 |
| 3-42. 8800b Power Supplies . . . . .                               | 3-89 |
| <br>IV. TROUBLESHOOTING  |      |
| 4-1. Introduction to Troubleshooting . . . . .                     | 4-5  |
| 4-2. Visual Inspection . . . . .                                   | 4-14 |
| 4-3. Preliminary Check . . . . .                                   | 4-15 |
| 4-4. Non-PROM Related Switch Problems . . . . .                    | 4-31 |
| 4-5. PROM Related Switch Problems . . . . .                        | 4-54 |
| <br>V. ASSEMBLY  |      |
| 5-1. General . . . . .   | 5-3  |
| 5-2. Assembly Hints . . . . .                                      | 5-3  |
| 5-3. Component Installation Instructions . . . . .                 | 5-5  |
| 5-9. Interface Card Assembly . . . . .                             | 5-13 |
| 5-19. Display/Control Board Assembly . . . . .                     | 5-19 |
| 5-32. CPU Board Assembly . . . . .                                 | 5-37 |
| 5-44. Power Supply Board Assembly . . . . .                        | 5-47 |
| 5-53. Back Panel Assembly . . . . .                                | 5-54 |
| 5-69. 18-Slot Motherboard Assembly . . . . .                       | 5-69 |

APPENDIX

## LIST OF TABLES

| Number |  | Page |
|--------|--|------|
| 2-1    | Altair 8800b Switches and Indicators . . . . .           | 2-2  |
| 2-2    | Power On Sequence . . . . .                              | 2-6  |
| 2-3    | Run Operation . . . . .                                  | 2-6  |
| 2-4    | Stop Operation . . . . .                                 | 2-7  |
| 2-5    | Examine Memory Operation . . . . .                       | 2-7  |
| 2-6    | Altering Memory Contents . . . . .                       | 2-8  |
| 2-7    | Examine Next Memory Location . . . . .                   | 2-8  |
| 2-8    | Altering Next Memory Contents . . . . .                  | 2-9  |
| 2-9    | Loading and Displaying Accumulator Data . . . . .        | 2-10 |
| 2-10   | Machine Language Bit Patterns . . . . .                  | 2-12 |
| 2-11   | Addition Program . . . . .                               | 2-13 |
| 2-12   | Addition Program Loading . . . . .                       | 2-14 |
| 3-1    | Symbol Definitions . . . . .                             | 3-5  |
| 3-2    | PROM Programs . . . . .                                  | 3-76 |
| 4-1    | Static Levels of the Most Common Problem Areas . . . . . | 4-9  |
| 4-2    | Mother Board Static Levels . . . . .                     | 4-11 |
| 4-3    | Voltage and Waveform Check . . . . .                     | 4-18 |
| 4-4    | Reset Check . . . . .                                    | 4-32 |
| 4-5    | Stop Check . . . . .                                     | 4-34 |
| 4-6    | Run Check . . . . .                                      | 4-43 |
| 4-7    | Single Step/Slow Check . . . . .                         | 4-44 |
| 4-8    | Protect/Unprotect Check . . . . .                        | 4-48 |
| 4-9    | Sense Switch Check . . . . .                             | 4-50 |
| 4-10   | Status Check . . . . .                                   | 4-53 |
| 4-11   | PROM Related Switch Problems . . . . .                   | 4-55 |

## LIST OF ILLUSTRATIONS

| Number | Title   | Page  |
|--------|---|-------|
| 1-1    | Altair 8800b Computer . . . . .                                     | 1-0   |
| 1-2    | Power Supply Board . . . . .  | 1-2   |
| 1-3    | Interface Board . . . . .   | 1-2   |
| 1-4    | CPU Board . . . . .   | 1-4   |
| 1-5    | Display/Control Board . . . . .                                     | 1-4   |
| 2-1    | Altair 8800b Front Panel . . . . .                                  | 2-1   |
| 3-1    | 8800b Block Diagram . . . . .                                       | 3-40  |
| 3-2    | Instruction Fetch Cycle Block Diagram . . . . .                     | 3-46  |
| 3-3    | Instruction Fetch Cycle Timing . . . . .                            | 3-47  |
| 3-4    | Memory Read Cycle Block Diagram . . . . .                           | 3-50  |
| 3-5    | Memory Read Cycle Timing . . . . .                                  | 3-53  |
| 3-6    | Input Read Cycle Block Diagram . . . . .                            | 3-56  |
| 3-7    | Input Read Cycle Timing . . . . .                                   | 3-57  |
| 3-8    | Memory Write Cycle Block Diagram . . . . .                          | 3-60  |
| 3-9    | Memory Write Cycle Timing . . . . .                                 | 3-62  |
| 3-10   | Output Write Cycle Block Diagram . . . . .                          | 3-65  |
| 3-11   | Output Write Cycle Timing . . . . .                                 | 3-67  |
| 3-12   | Front Panel Block Diagram . . . . .                                 | 3-69  |
| 3-13   | PROM Block Diagram . . . . .  | 3-75  |
| 3-14   | CPU Schematic . . . . .   | 3-91  |
| 3-15   | Interface Schematic (sheet 1 of 3) . . . . .                        | 3-93  |
| 3-15   | Interface Schematic (sheet 2 of 3) . . . . .                        | 3-95  |
| 3-15   | Interface Schematic (sheet 3 of 3) . . . . .                        | 3-97  |
| 3-16   | Display/Control Schematic (sheet 1 of 3) . . . . .                  | 3-99  |
| 3-16   | Display/Control Schematic (sheet 2 of 3) . . . . .                  | 3-101 |
| 3-16   | Display/Control Schematic (sheet 3 of 3) . . . . .                  | 3-103 |
| 3-17   | Power Supply Board Schematic . . . . .                              | 3-105 |
| 3-18   | CPU Voltage Regulator Schematic . . . . .                           | 3-107 |
| 3-19   | Interface Voltage Regulator Schematic . . . . .                     | 3-109 |
| 3-20   | Display/Control Voltage Regulator Schematic . . . . .               | 3-111 |
| 5-1    | Typical Silkscreen . . . . .  | 5-4   |
| 5-2    | Interface IC Installation . . . . .                                 | 5-2   |
| 5-3    | Interface Resistor Installation . . . . .                           | 5-14  |
| 5-4    | Interface Suppressor Capacitor and Capacitor Installation . . . . . | 5-15  |
| 5-5    | Interface Jumper Connections . . . . .                              | 5-16  |
| 5-6    | Interface Ferrite Bead Installation . . . . .                       | 5-16  |
| 5-7    | Interface Voltage Regulator Installation . . . . .                  | 5-17  |
| 5-8    | Interface Male Connector Installation . . . . .                     | 5-18  |
| 5-9    | Interface Ribbon Cable Plug Installation . . . . .                  | 5-19  |
| 5-10   | Display/Control IC Socket and IC Installation . . . . .             | 5-21  |
| 5-11   | Display/Control IC Installation . . . . .                           | 5-22  |
| 5-12   | Display/Control Resistor Installation . . . . .                     | 5-23  |
| 5-13   | Display/Control Resistor Pack Installation . . . . .                | 5-24  |
| 5-14   | Display/Control Substitute Resistor Assembly . . . . .              | 5-25  |
| 5-15   | Display/Control Jumper Connections . . . . .                        | 5-26  |
| 5-16   | Display/Control Suppressor Capacitor Installation . . . . .         | 5-27  |
| 5-17   | Display/Control Capacitor Installation . . . . .                    | 5-28  |
| 5-18   | Display/Control Diode and Ferrite Bead Installation . . . . .       | 5-29  |

LIST OF ILLUSTRATIONS - Continued

| Number | Title   | Page |
|--------|---|------|
| 5-19   | Display/Control Voltage Regulator Installation. . . . .                         | 5-30 |
| 5-20A  | Display/Control Switch Installation . . . . .                                   | 5-31 |
| 5-20B  | Display/Control Switch Installation . . . . .                                   | 5-32 |
| 5-21   | Display/Control Switch Nut Placement. . . . .                                   | 5-33 |
| 5-22   | Covering LED Holes on Sub Panel . . . . .                                       | 5-33 |
| 5-23   | Display/Control LED Orientation and Installation. . . . .                       | 5-34 |
| 5-24   | Securing Sub Panel Over Display/Control Board . . . . .                         | 5-34 |
| 5-25   | Display/Control LED Adjustment. . . . .   | 5-35 |
| 5-26   | CPU IC Installation . . . . .   | 5-37 |
| 5-27   | CPU Resistor Installation . . . . .   | 5-38 |
| 5-28   | CPU Suppressor Capacitor Installation . . . . .                                 | 5-39 |
| 5-29   | CPU Capacitor Installation. . . . .   | 5-40 |
| 5-30   | CPU Diode Installation. . . . .   | 5-41 |
| 5-31   | CPU Ferrite Bead Installation . . . . .   | 5-42 |
| 5-32   | CPU Voltage Regulator Installation. . . . .                                     | 5-43 |
| 5-33   | CPU Transistor and Male Connector Installation. . . . .                         | 5-44 |
| 5-34   | CPU Crystal Installation. . . . .   | 5-45 |
| 5-35   | CPU IC Socket and IC Installation . . . . .                                     | 5-46 |
| 5-36   | Power Supply Capacitor and Resistor Installation. . . . .                       | 5-47 |
| 5-37   | Power Supply Diode Installation . . . . .                                       | 5-48 |
| 5-38   | Power Supply Transistor Installation. . . . .                                   | 5-49 |
| 5-39   | Power Supply Bridge Rectifier . . . . .   | 5-50 |
| 5-40   | Power Supply Terminal Block Screw Removal . . . . .                             | 5-51 |
| 5-41   | Power Supply Terminal Block Screw Insertion . . . . .                           | 5-51 |
| 5-42   | Power Supply Terminal Block Shorting Link Insertion . . . . .                   | 5-51 |
| 5-43   | Power Supply Board Mounting to Cross Member . . . . .                           | 5-52 |
| 5-44   | Power Supply Capacitor and Clamp Installation<br>(For One Capacitor) . . . . .  | 5-53 |
| 5-45   | Power Supply Capacitor and Clamp Installation<br>(For Two Capacitors) . . . . . | 5-53 |
| 5-46   | Completed Back Panel Assembly . . . . .   | 5-54 |
| 5-47   | Terminal End Sizes . . . . .  | 5-55 |
| 5-48   | Terminal End Attachment . . . . .   | 5-56 |
| 5-49A  | Connector Pin and Connector Socket Wire Insertion . . . . .                     | 5-57 |
| 5-49B  | Pin and Socket Housing Assembly . . . . .                                       | 5-57 |
| 5-50   | Wiring Diagram . . . . .  | 5-58 |
| 5-51   | Bridge Rectifier Installation . . . . .   | 5-60 |
| 5-52   | Fan Mounting . . . . .  | 5-61 |
| 5-53   | Fuse Holder Installation . . . . .  | 5-62 |
| 5-54   | AC Power Cord Installation . . . . .  | 5-62 |
| 5-55   | "L" Bracket Mounting . . . . .  | 5-63 |
| 5-56   | Terminal End Attachment . . . . .   | 5-63 |
| 5-57   | Terminal Block Mounting . . . . .   | 5-63 |
| 5-58   | Pin Housing Insertion . . . . .   | 5-65 |
| 5-59   | Transformer Mounting . . . . .  | 5-66 |
| 5-60   | Back Panel Mounting . . . . .   | 5-67 |
| 5-61   | Motherboard Wire Connections . . . . .  | 5-68 |
| 5-62   | Card Guide Mounting . . . . .   | 5-70 |
| 5-63   | Chassis Ground Connection . . . . .   | 5-71 |
| 5-64   | On/Off Switch Wiring . . . . .  | 5-73 |
| 5-65   | Female Connector Wiring for P3 . . . . .  | 5-75 |

ALTAIR 8800b  
SECTION I  
INTRODUCTION

## SECTION I

### INTRODUCTION

#### 1-1. SCOPE

This ALTAIR™ 8800b Documentation provides a general description of the various printed circuit cards contained in the ALTAIR 8800b and detailed theory of their operation. Included in the documentation is an operator's guide which familiarizes the operator with the various switches and indicators on the ALTAIR 8800b front panel. Detailed assembly instructions are also provided.

#### 1-2. ARRANGEMENT

This manual contains five sections as follows:

1. Section I contains a general description of the ALTAIR 8800b computer and associated printed circuit cards.
2. Section II contains information on the controls and indicators which are located on the ALTAIR 8800b front panel.
3. Section III contains a detailed theory explanation of the ALTAIR 8800b circuit operation.
4. Section IV contains troubleshooting information for the ALTAIR 8800b.
5. Section V contains the detailed assembly instructions for the ALTAIR 8800b.

#### 1-3. DESCRIPTION

The ALTAIR 8800b computer (Figure 1-1) is a general purpose, byte-oriented machine (8-bit word). It uses a common 100-pin bus structure that allows for expansion of either standard or custom plug-in modules. It supports up to 64K of directly addressable memory and can address 256 separate input and output devices. The ALTAIR 8800b computer has 78 basic machine language instructions and consists of a power supply board, an interface board, a central processing unit (CPU) board, and a display/control board.

#### 1-4. POWER SUPPLY BOARD (Figure 1-2)

The Power Supply Board provides two of the three output voltages to the ALTAIR 8800b computer bus, a positive and negative 18 volts. It includes a bridge rectifier circuit and associated filter capacitors, a 10-pin terminal block connector, and the regulating transistors for the positive and negative 18 volt supplies.

#### 1-5. INTERFACE BOARD (Figure 1-3)

The Interface Board buffers all signals between the display/control board and the ALTAIR 8800b bus. It also contains eight parallel data lines which transfer data to the CPU from the Display/Control board.



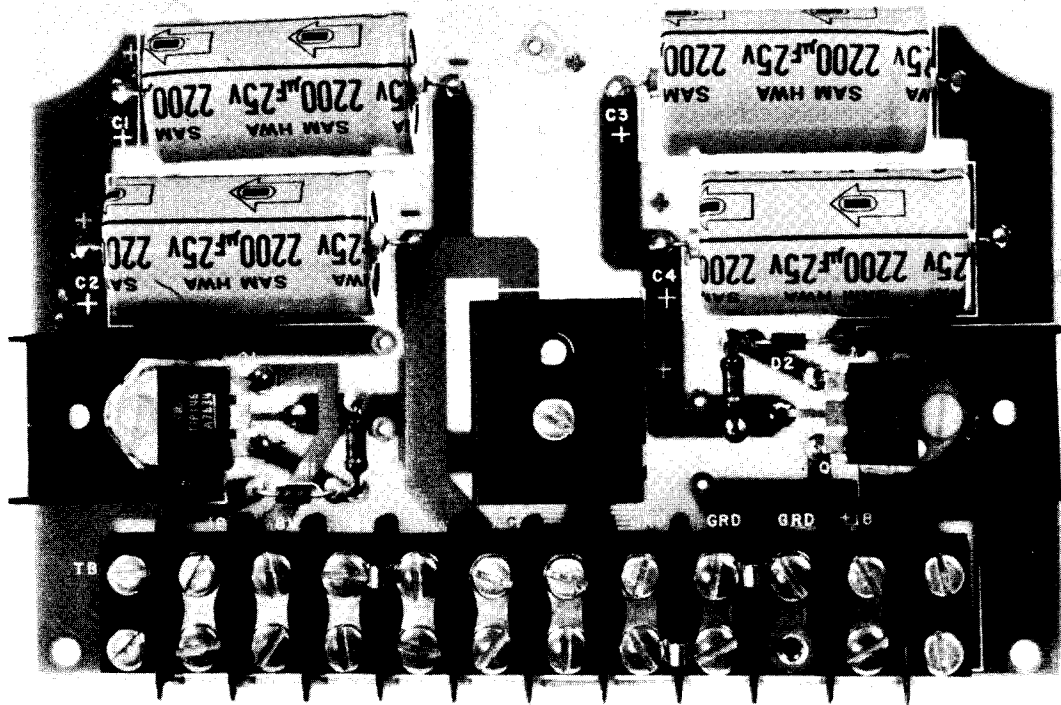

Figure 2. Power Supply Board

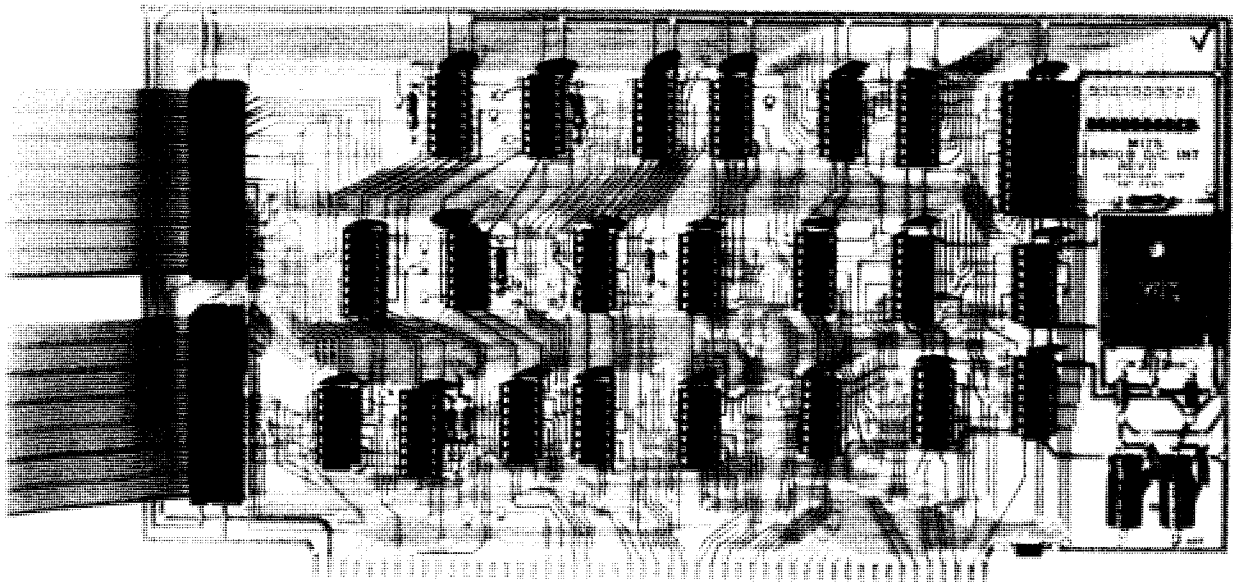
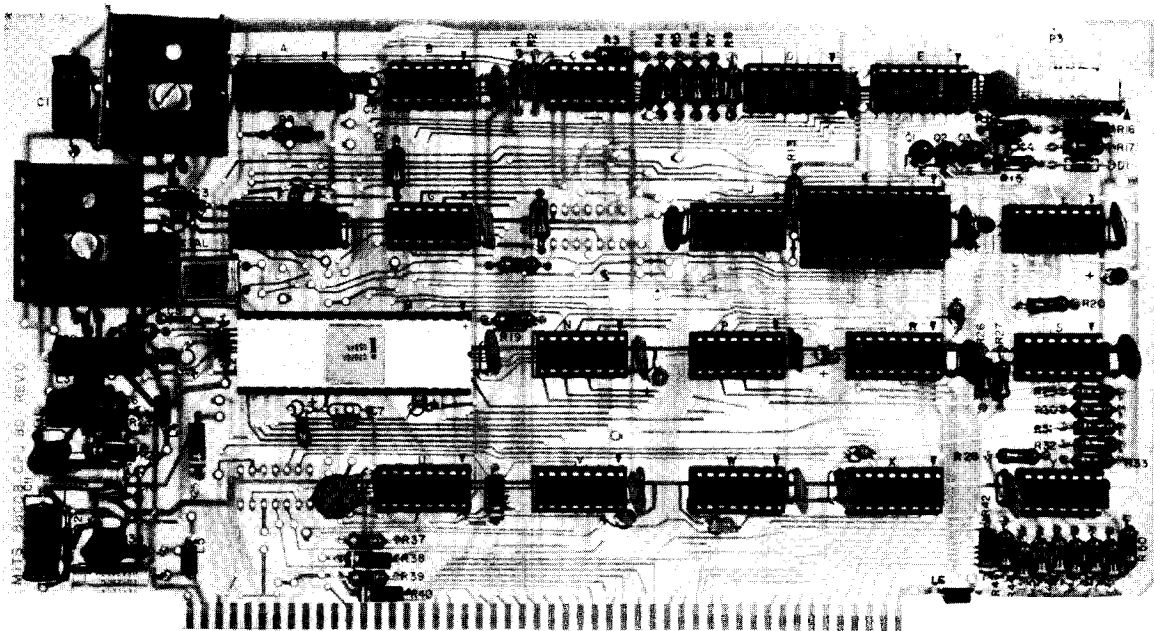
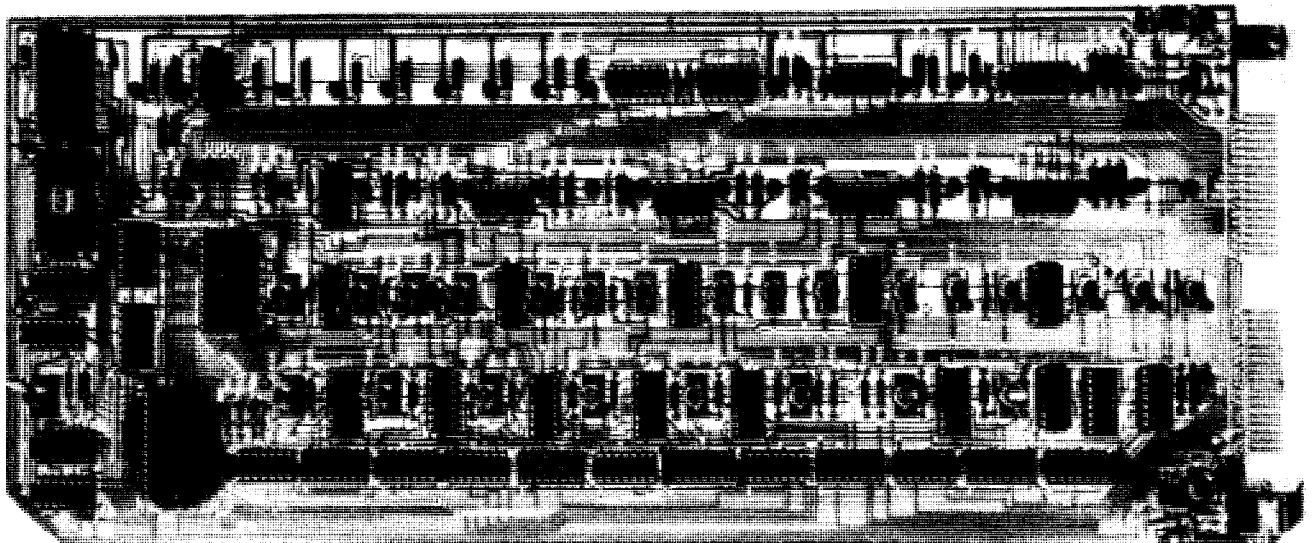

Figure 3. Interface Board



**Figure 4. CPU Board**



**Figure 5. Display/Control Board**

1-6. CPU BOARD (Figure 1-4)

The CPU board controls and processes all instructions and data within the ALTAIR 8800b computer. It contains the Intel Corporation model 8080A microprocessor circuit, the master timing circuit, eight input and eight output data lines to the ALTAIR bus control circuits.

1-7. DISPLAY/CONTROL BOARD (Figure 1-5)

The Display/Control Board conditions all ALTAIR 8800b front panel switches and receives information to be displayed on the front panel. It contains a programmable read only memory (PROM), switch and display control circuits, and control circuits to condition the CPU.

ALTAIR 8800b  
SECTION II  
OPERATOR'S GUIDE

## 2-1. GENERAL

The Operators Guide contains information on the ALTAIR 8800b computer (8800b) front panel controls and indicators. It includes general switch operation exercises and a sample program which is intended to familiarize the operator with the various front panel operations. Provided in this section are portions of the Intel 8080 Microcomputer Systems Users Manual which contain Central Processor Unit, Interface and Software information. Additional programs available to the user are described in the ALTAIR Software Library. Update information is contained with your unit.

## 2-2. FRONT PANEL SWITCHES AND INDICATORS

The Front Panel switches permit the operator to perform various ALTAIR 8800b operations, and the indicators display address information, data information, and primary status control line information. Refer to Figure 2-1 for the location of the switches and indicators and Table 2-1 for an explanation of each.

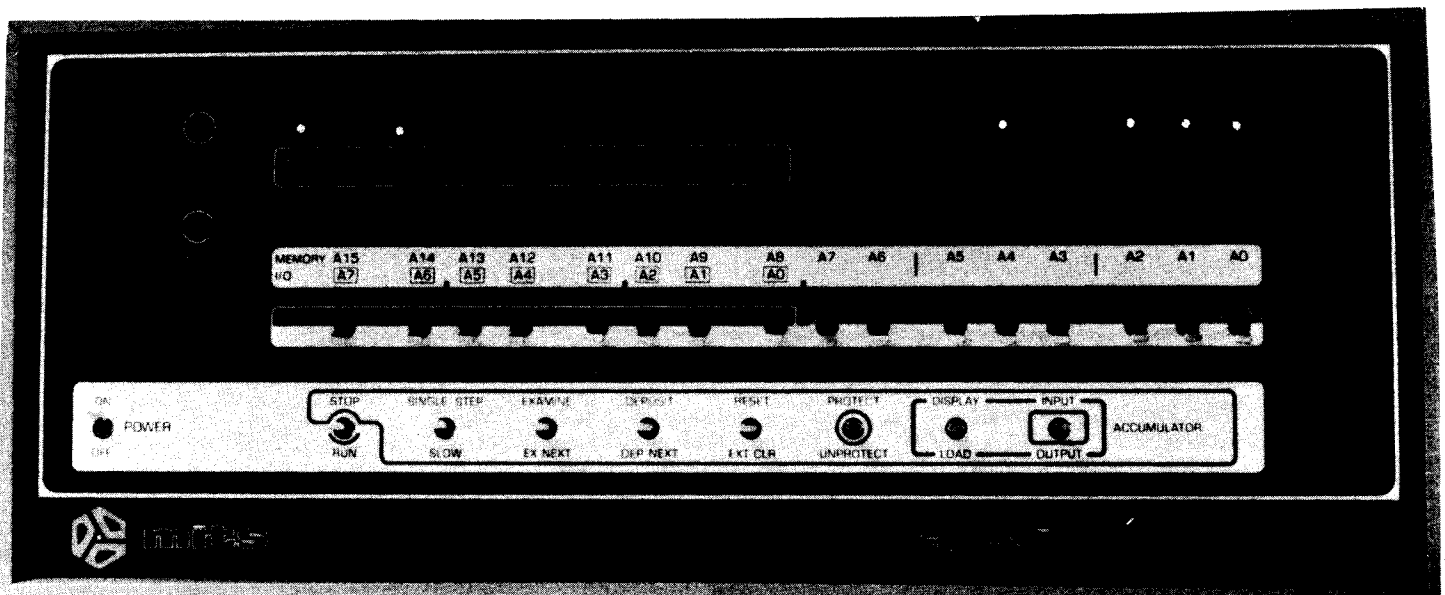

Figure 2-1. Altair 8800b Front Panel

Table 2-1. ALTAIR 8800b Switches and Indicators

| Switch               | Function or Indication   |
|----------------------|--|
| POWER ON/OFF         | Applies power to the ALTAIR 8800b  |
| STOP/RUN             | The RUN position allows the CPU to process data and disables all functions on the front panel except reset. The STOP position conditions the CPU to a wait state and enables all functions on the front panel.   |
| SINGLE STEP/<br>SLOW | The SINGLE STEP position allows execution of one machine cycle or one instruction cycle (depending upon the option selected). SLOW position allows execution of machine or instruction cycles at a rate of approximately 2 cycles per second. (Normal speed is approximately 500,000 machine cycles per second.) The CPU will execute the cycles as long as the SLOW position is maintained. |
| EXAMINE/<br>EX NEXT  | The EXAMINE position allows the operator to examine the memory address selected on the A0-A15 MEMORY switches. The contents at that address are displayed on the DATA D0-D7 indicators. The EX NEXT position allows the operator to examine the next sequential memory address. Each time EX NEXT is actuated, the contents of the next sequential memory address are displayed.             |

Table 2-1. ALTAIR 8800b Switches and Indicators - Continued

| Switch  | Function or Indication  |
|---|---|
| DEPOSIT/<br>DEP NEXT  | The DEPOSIT position stores the contents of the lower address switches (A0-A7) into the memory address that is displayed on the MEMORY address A0-A15 indicators. The DEP NEXT position stores the contents of the lower address switches (A0-A7) into the next successive memory address.          |
| RESET/<br>EXT CLR   | The RESET position resets the program counter to zero and the interrupt enable flag in the CPU. The EXT CLR position produces an external clear signal on the system bus which generally clears an input/output.  |
| PROTECT/<br>UNPROTECT*  | The PROTECT position conditions the write protect circuits on the currently addressed memory board, preventing data in that block of memory from being changed. The front panel or the CPU cannot affect the memory when protected. UNPROTECT position allows the contents of memory to be changed. |
| ACCUMULATOR<br>DISPLAY/LOAD   | The DISPLAY position allows the contents of the CPU accumulator register to be displayed on the DATA D0-D7 indicators. The LOAD position allows the lower eight address switch (A0-A7) information to be stored in the CPU accumulator register.  |
| *Protect switch only applies to memory boards with a protect circuit. |   |

Table 2-1. ALTAIR 8800b Switches and Indicators - Continued

| Switch or Indicator        | Function or Indication   |
|----------------------------|--|
| INPUT/<br>OUTPUT           | The INPUT position allows an external device, selected on the I/O A0-A7 switches (upper eight address switches), to input data into the CPU accumulator. The OUTPUT position allows an external device, selected on the I/O A0-A7 switches, to receive data from the CPU accumulator register. |
| Address Switches<br>A0-A15 | These switches are used to select an address in memory or to enter data. The up position denotes a one bit and the down position denotes a zero bit.   |
| SENSE switches<br>A8-A15   | The upper eight address switches (A8-A15) also function as SENSE switches. The data present on these switches is stored in the accumulator if an input from channel 377 <sub>g</sub> (front panel) is executed.  |
| MEMORY A0-A15              | Display the memory address being examined or loaded with data.   |
| PROTECT                    | Memory is protected.   |
| INTE                       | Interrupts are enabled.  |
| MEMR                       | The CPU is reading data from memory.   |
| INP                        | An external device is inputting data to the CPU.   |
| M1                         | The CPU is in machine cycle one of an instruction cycle.   |
| OUT                        | The CPU is outputting data to an external device.  |



Table 2-1. ALTAIR 8800b Switches and Indicators - Continued

| Indicator     | Function or Indication  |
|---------------|---|
| HLTA<br>STACK | The CPU is in a halt condition.<br>The address bus contains the address of the stack pointer. |
| WO            | The CPU is writing out data to an external device or memory.                                  |
| INT           | The CPU has acknowledged an interrupt request.  |
| DATA D0-D7    | Data from memory, an external device, or the CPU  |
| WAIT<br>HLDA  | The CPU is in a wait condition.<br>The CPU has acknowledged a hold signal.                    |

### 2-3. FRONT PANEL SWITCH APPLICATIONS

The following switch applications are intended to familiarize the operator with the ALTAIR 8800b front panel switches and indicators. Perform the operations in a sequential manner as shown in the following tables.

### 2-4. POWER ON SEQUENCE (Table 2-2)

The power on sequence resets the CPU program counter to the first memory address and places the CPU in a wait condition at the beginning of an instruction cycle.

Table 2-2. Power On Sequence

| Step | Function                                | Indication   |
|------|---|--|
| 1    | Position the POWER ON/OFF switch to ON. | MEMR, MI, and WAIT indicators are on. Some DATA D0-D7 indicators may also be on. All other indicators are off. |

### 2-5. RUN OPERATION (Table 2-3)

The run operation releases the CPU from a wait condition, and allows it to execute a program. When the run operation is enabled, all other front panel switches are inactive except the RESET switch.

Table 2-3. Run Operation

| Step | Function   | Indication  |
|------|--|---|
| 1    | Momentarily position the STOP/RUN switch to RUN. | WAIT indicator is off (or may be dimly lit). The machine can now execute a program. |

## 2-6. STOP OPERATION (Table 2-4)

The stop operation places the CPU in a wait condition and allows the operator to use the switches on the 8800b front panel.

Table 2-4. Stop Operation

| Step | Function                              | Indication   |
|------|---------------------------------------|--|
| 1    | Position the STOP/RUN switch to STOP. | WAIT, MEMR, and M1 indicators are on. The operator now has control of the front panel. |

## 2-7. EXAMINE MEMORY OPERATION (Table 2-5)

This procedure allows the operator to select a memory address and examine its contents.

Table 2-5. Examine Memory Operation

| Step | Function  | Indication   |
|------|---|--|
| 1    | Position the address switches A0-A15 down.      |  |
| 2    | Position the EXAMINE/EX NEXT switch to EXAMINE. | A0 through A15 indicators are off, indicating memory address location $000_8$ is being examined. DATA D0 through D7 indicators are displaying the contents of location $000_8$ . |
| 3    | Position address switches A1 and A2 up.         |  |
| 4    | Position the EXAMINE/EX NEXT switch to EXAMINE. | A1 and A2 indicators are on, indicating memory address $006_8$ is being examined. DATA D0 through D7 indicators are displaying the contents of location $006_8$ .                |

2-8. ALTERING MEMORY CONTENTS (Table 2-6)

This procedure allows the operator to select a memory address and change its contents.

Table 2-6. Altering Memory Contents

| Step | Function   | Indication  |
|------|--|---|
| 1    | Position address switch A5 up and the remaining switches down. | A5 indicator is on, indicating memory address $040_8$ . DATA D0 through D7 indicators are displaying the contents of location $040_8$ . |
| 2    | Position the EXAMINE/EX NEXT switch to EXAMINE                 |   |
| 3    | Position the A0 through A7 address switches up.                | DATA D0 through D7 indicators are on, indicating the new data that has been placed in address location $040_8$ .                        |
| 4    | Position the DEPOSIT/DEP NEXT to DEPOSIT                       |   |

2-9. EXAMINE NEXT MEMORY LOCATION (Table 2-7)

This procedure allows the operator to examine the next sequential memory location, as determined by the address switches.

Table 2-7. Examine Next Memory Location

| Step | Function   | Indication   |
|------|--|--|
| 1    | Position address switches A0 and A5 up, and the remaining switches down. | A0 and A5 indicators are on, indicating memory address $041_8$ . |
| 2    | Position the EXAMINE/EX NEXT switch to EXAMINE                           |  |

Table 2-7. Examine Next Memory Location - Continued

| Step | Function  | Indication   |
|------|---|--|
| 3    | Position address switches A1, A4, and A6 up, and the remaining switches down. |  |
| 4    | Position the DEPOSIT/DEP NEXT switch to DEPOSIT                               | DATA D1, D4, and D6 indicators are on.   |
| 5    | Position address switch A5 up, and the remaining switches down.               |  |
| 6    | Position the EXAMINE/EX NEXT switch to EXAMINE                                | A5 indicator is on, indicating memory address $040_8$ . DATA D0 through D7 indicators are on.    |
| 7    | Position the EXAMINE/EX NEXT switch to EX NEXT                                | A5 and A0 indicators are on, indicating address $041_8$ . DATA D1, D4, and D6 indicators are on. |

2-10. ALTER NEXT MEMORY LOCATION CONTENTS (Table 2-8)

This procedure allows the operator to select a memory address and change the contents of the address that immediately follows.

Table 2-8. Altering Next Memory Contents

| Step | Function   | Indication                   |
|------|--|------------------------------|
| 1    | Position address switches A0 and A5 up, and the remaining switches down. |                              |
| 2    | Position the EXAMINE/EX NEXT switch to EXAMINE                           | A0 and A5 indicators are on. |
| 3    | Position address switches A0 through A7 up                               |                              |

Table 2-8. Altering Next Memory Contents - Continued

| Step | Function   | Indication   |
|------|--|--|
| 4    | Position the DEPOSIT/<br>DEP NEXT switch to DEP<br>NEXT  | A1 and A5 indicators are<br>on, indicating $042_8$ .<br>DATA D0 through D7 are<br>on, displaying the new<br>contents of location $042_8$ . |
| 5    | To verify, position ad-<br>dress switches A5 and A1<br>up, and the remaining<br>switches down. |  |
| 6    | Position the EXAMINE/<br>EX NEXT switch to EXAMINE   | A1 and A5 indicators are<br>on, and DATA D0 through<br>D7 are on.  |

2-11. LOADING AND DISPLAYING ACCUMULATOR DATA (Table 2-9)

This procedure allows the operator to load new data into the accumulator or check the contents of the accumulator.

Table 2-9. Loading and Displaying Accumulator Data

| Step | Function  | Indication   |
|------|---|--|
| 1    | Position address switches<br>A0, A1, and A2 up, and the<br>remaining switches down. |  |
| 2    | Position the ACCUMULATOR<br>DISPLAY/LOAD switch to LOAD                             |  |
| 3    | Position the ACCUMULATOR<br>DISPLAY/LOAD switch to<br>DISPLAY                       | DATA D0, D1, and D2<br>indicators are on<br>while "DISPLAY" is<br>activated. |

## 2-12. LOADING A SAMPLE PROGRAM

The sample program is designed to retrieve two numbers from memory, add them together, and store the result in memory. The exact program in mnemonic form can be written as follows:

0. LDA
1. MOV B,A
2. LDA
3. ADD B
4. STA
5. JMP

The mnemonics for all 78 8800b instructions are explained in detail in the excerpt from the Intel 8080 Microcomputer System User's Manual contained in this section. However, the instructions used in this program are explained as follows:

0. LDA--Load the accumulator with the contents of a specified memory address.
1. MOV B,A--Move the contents of the accumulator into register B.
2. LDA--Same as 0.
3. ADD B--Add the contents of register B to the contents of the accumulator and store the result in the accumulator.
4. STA--Store the contents of the accumulator in a specified memory address.
5. JMP--Jump to the first step in the program.

Step 5, the JMP instruction (followed by the memory address of the first instruction), causes the CPU to "jump" back to the beginning of the sample program and execute the program repeatedly until the CPU is halted. Without a JMP instruction the CPU would continue to run randomly through memory.

## 2-13. LOADING THE PROGRAM

To load the program into the 8800b, first determine the memory addresses for the two numbers to be added and where the result is to be stored. Store the program instructions in successive memory addresses, beginning at the first memory address,  $000_8$ . In this example the first number to be added will be located at memory address  $200_8$  (10 000 000), the second at memory address  $201_8$  (10 000 001), and the sum will be stored in memory address  $202_8$  (10 000 010). Now that the memory addresses have been specified, the program can be converted into its machine bit patterns (Table 2-10).

Table 2-10. Machine Language Bit Patterns

| <u>MNEMONIC</u> | <u>BIT PATTERN</u>                     | <u>EXPLANATION</u>   |
|-----------------|--|--|
| LDA 200         | 00 111 010<br>10 000 000<br>00 000 000 | Load Accumulator in the CPU with contents of Memory address 200 <sub>8</sub> (2 bytes required for memory addresses) |
| MOV B,A         | 01 000 111                             | Move Accumulator data to Register B  |
| LDA 201         | 00 111 010<br>10 000 001<br>00 000 000 | Load Accumulator with the contents of Memory address 201 <sub>8</sub>  |
| ADD B           | 10 000 000                             | Add Register B to Accumulator  |
| STA 202         | 00 110 010<br>10 000 010<br>00 000 000 | Store the Accumulator contents in Memory address 202 <sub>8</sub>  |
| JMP 000         | 11 000 011<br>00 000 000<br>00 000 000 | Jump to Memory location 0.   |

The octal equivalent of each bit pattern is also frequently included in the program listing. It is easy to load octal numbers on the front panel switches, since it is only necessary to know the binary equivalents for the numbers 0-7. The resulting program, including octal equivalents, may be written as shown in Table 2-11:



Table 2-11. Addition Program

| <u>MEMORY ADDRESS</u> | <u>MNEMONIC</u> | <u>BIT PATTERN</u> | <u>OCTAL EQUIVALENT</u> |
|-----------------------|-----------------|--------------------|-------------------------|
| 000                   | LDA 200         | 00 111 010         | 0 7 2                   |
| 001                   | (address)       | 10 000 000         | 2 0 0                   |
| 002                   | (address)       | 00 000 000         | 0 0 0                   |
| 003                   | MOV B,A         | 01 000 111         | 1 0 7                   |
| 004                   | LDA 201         | 00 111 010         | 0 7 2                   |
| 005                   | (address)       | 10 000 001         | 2 0 1                   |
| 006                   | (address)       | 00 000 000         | 0 0 0                   |
| 007                   | ADD B           | 10 000 000         | 2 0 0                   |
| 010                   | STA 202         | 00 011 010         | 0 6 2                   |
| 011                   | (address)       | 10 000 010         | 2 0 2                   |
| 012                   | (address)       | 00 000 000         | 0 0 0                   |
| 013                   | JMP 000         | 11 000 011         | 3 0 3                   |
| 014                   | (address)       | 00 000 000         | 0 0 0                   |
| 015                   | (address)       | 00 000 000         | 0 0 0                   |

Using the front panel switches, the program may now be entered into the computer. To begin loading the program at the first memory address 000, position the RESET/CLR switch to RESET. The data to be stored in address 000 is entered on address switches A0 through A7. After the address switches are set, position the DEPOSIT/DEP NEXT switch to DEPOSIT to enter the A0-A7 bit pattern into memory address 000. Enter the second byte of data on the address switches and position the DEPOSIT/DEP NEXT switch to DEP NEXT. The bit pattern will be loaded automatically into the next sequential memory address (001). Continue loading the data into memory for the remainder of the program. The complete program loading procedure is shown in Table 2-12:

Table 2-12. Addition Program Loading

| <u>MEMORY ADDRESS</u> | <u>ADDRESS SWITCHES DATA 0-7</u> | <u>CONTROL SWITCH</u> |
|-----------------------|----------------------------------|-----------------------|
|                       |                                  | RESET                 |
| 000                   | 00 111 010                       | DEPOSIT               |
| 001                   | 10 000 000                       | DEPOSIT NEXT          |
| 002                   | 00 000 000                       | DEPOSIT NEXT          |
| 003                   | 01 000 111                       | DEPOSIT NEXT          |
| 004                   | 00 111 010                       | DEPOSIT NEXT          |
| 005                   | 10 000 001                       | DEPOSIT NEXT          |
| 006                   | 00 000 000                       | DEPOSIT NEXT          |
| 007                   | 10 000 000                       | DEPOSIT NEXT          |
| 010                   | 00 110 010                       | DEPOSIT NEXT          |
| 011                   | 10 000 010                       | DEPOSIT NEXT          |
| 012                   | 00 000 000                       | DEPOSIT NEXT          |
| 013                   | 11 000 011                       | DEPOSIT NEXT          |
| 014                   | 00 000 000                       | DEPOSIT NEXT          |
| 015                   | 00 000 000                       | DEPOSIT NEXT          |

The program is now ready to be run, but first it is necessary to store data at each of the two memory addresses ( $200_8$  and  $201_8$ ) to be added together. To load the first address, set address switches A0-A7 to  $10\ 000\ 000_2$  and position the EXAMINE/EX NEXT switch to EXAMINE. Now load any desired number into this address by using address switches A0-A7. When the number has been loaded onto the switches, position the DEPOSIT/DEP NEXT to DEPOSIT to load the data into memory. To load the next address, enter a second number on the address switches A0-A7 and position the DEPOSIT/DEP NEXT switch to DEP NEXT. Since sequential memory addresses were selected, the number will be loaded automatically into the proper address ( $10\ 000\ 001_2$ ). Once the program has been loaded and the two numbers have been stored in memory locations  $200_8$  and  $201_8$ , the program can be run. Return to address 000 by positioning all A0-A7 address switches down and positioning the EXAMINE/EX NEXT switch to EXAMINE. Then position the STOP/RUN switch to RUN. Wait a moment and position the STOP/RUN switch to STOP. Check the answer of your addition program by selecting memory location  $202_8$  on the address switches and positioning the EXAMINE/EX NEXT switch to EXAMINE. The result is displayed on the DATA D0-D7 indicators.

#### 2-14. INTEL 8080 MICROCOMPUTER SYSTEMS USER'S INFORMATION

Pages 2-16 through 2-65 are excerpts from the Intel 8080 Microcomputer Systems User's Manual, reprinted by permission of Intel Corporation, Copyright 1975. Included is detailed Central Processor Unit, Interface and Software information pertaining to the 8080 Microcomputer System.

# CHAPTER 1 THE FUNCTIONS OF A COMPUTER

This chapter introduces certain basic computer concepts. It provides background information and definitions which will be useful in later chapters of this manual. Those already familiar with computers may skip this material, at their option.

## A TYPICAL COMPUTER SYSTEM

A typical digital computer consists of:

- a) A central processor unit (CPU)
- b) A memory
- c) Input/output (I/O) ports

The memory serves as a place to store **Instructions**, the coded pieces of information that direct the activities of the CPU, and **Data**, the coded pieces of information that are processed by the CPU. A group of logically related instructions stored in memory is referred to as a **Program**. The CPU "reads" each instruction from memory in a logically determined sequence, and uses it to initiate processing actions. If the program sequence is coherent and logical, processing the program will produce intelligible and useful results.

The memory is also used to store the data to be manipulated, as well as the instructions that direct that manipulation. The program must be organized such that the CPU does not read a non-instruction word when it expects to see an instruction. The CPU can rapidly access any data stored in memory; but often the memory is not large enough to store the entire data bank required for a particular application. The problem can be resolved by providing the computer with one or more **Input Ports**. The CPU can address these ports and input the data contained there. The addition of input ports enables the computer to receive information from external equipment (such as a paper tape reader or floppy disk) at high rates of speed and in large volumes.

A computer also requires one or more **Output Ports** that permit the CPU to communicate the result of its processing to the outside world. The output may go to a display, for use by a human operator, to a peripheral device that produces "hard-copy," such as a line-printer, to a

peripheral storage device, such as a floppy disk unit, or the output may constitute process control signals that direct the operations of another system, such as an automated assembly line. Like input ports, output ports are addressable. The input and output ports together permit the processor to communicate with the outside world.

The CPU unifies the system. It controls the functions performed by the other components. The CPU must be able to fetch instructions from memory, decode their binary contents and execute them. It must also be able to reference memory and I/O ports as necessary in the execution of instructions. In addition, the CPU should be able to recognize and respond to certain external control signals, such as **INTERRUPT** and **WAIT** requests. The functional units within a CPU that enable it to perform these functions are described below.

## THE ARCHITECTURE OF A CPU

A typical central processor unit (CPU) consists of the following interconnected functional units:

- Registers
- Arithmetic/Logic Unit (ALU)
- Control Circuitry

Registers are temporary storage units within the CPU. Some registers, such as the program counter and instruction register, have dedicated uses. Other registers, such as the accumulator, are for more general purpose use.

### Accumulator:

The accumulator usually stores one of the operands to be manipulated by the ALU. A typical instruction might direct the ALU to add the contents of some other register to the contents of the accumulator and store the result in the accumulator itself. In general, the accumulator is both a source (operand) and a destination (result) register.

Often a CPU will include a number of additional general purpose registers that can be used to store operands or intermediate data. The availability of general purpose

registers eliminates the need to "shuffle" intermediate results back and forth between memory and the accumulator, thus improving processing speed and efficiency.

### **Program Counter (Jumps, Subroutines and the Stack):**

The instructions that make up a program are stored in the system's memory. The central processor references the contents of memory, in order to determine what action is appropriate. This means that the processor must know which location contains the next instruction.

Each of the locations in memory is numbered, to distinguish it from all other locations in memory. The number which identifies a memory location is called its **Address**.

The processor maintains a counter which contains the address of the next program instruction. This register is called the **Program Counter**. The processor updates the program counter by adding "1" to the counter each time it fetches an instruction, so that the program counter is always current (pointing to the next instruction).

The programmer therefore stores his instructions in numerically adjacent addresses, so that the lower addresses contain the first instructions to be executed and the higher addresses contain later instructions. The only time the programmer may violate this sequential rule is when an instruction in one section of memory is a **Jump** instruction to another section of memory.

A jump instruction contains the address of the instruction which is to follow it. The next instruction may be stored in any memory location, as long as the programmed jump specifies the correct address. During the execution of a jump instruction, the processor replaces the contents of its program counter with the address embodied in the Jump. Thus, the logical continuity of the program is maintained.

A special kind of program jump occurs when the stored program "Calls" a subroutine. In this kind of jump, the processor is required to "remember" the contents of the program counter at the time that the jump occurs. This enables the processor to resume execution of the main program when it is finished with the last instruction of the subroutine.

A **Subroutine** is a program within a program. Usually it is a general-purpose set of instructions that must be executed repeatedly in the course of a main program. Routines which calculate the square, the sine, or the logarithm of a program variable are good examples of functions often written as subroutines. Other examples might be programs designed for inputting or outputting data to a particular peripheral device.

The processor has a special way of handling subroutines, in order to insure an orderly return to the main program. When the processor receives a Call instruction, it increments the Program Counter and stores the counter's contents in a reserved memory area known as the **Stack**. The Stack thus saves the address of the instruction to be executed after the subroutine is completed. Then the pro-

cessor loads the address specified in the Call into its Program Counter. The next instruction fetched will therefore be the first step of the subroutine.

The last instruction in any subroutine is a **Return**. Such an instruction need specify no address. When the processor fetches a Return instruction, it simply replaces the current contents of the Program Counter with the address on the top of the stack. This causes the processor to resume execution of the calling program at the point immediately following the original Call Instruction.

Subroutines are often **Nested**; that is, one subroutine will sometimes call a second subroutine. The second may call a third, and so on. This is perfectly acceptable, as long as the processor has enough capacity to store the necessary return addresses, and the logical provision for doing so. In other words, the maximum depth of nesting is determined by the depth of the stack itself. If the stack has space for storing three return addresses, then three levels of subroutines may be accommodated.

Processors have different ways of maintaining stacks. Some have facilities for the storage of return addresses built into the processor itself. Other processors use a reserved area of external memory as the stack and simply maintain a **Pointer** register which contains the address of the most recent stack entry. The external stack allows virtually unlimited subroutine nesting. In addition, if the processor provides instructions that cause the contents of the accumulator and other general purpose registers to be "pushed" onto the stack or "popped" off the stack via the address stored in the stack pointer, multi-level interrupt processing (described later in this chapter) is possible. The status of the processor (i.e., the contents of all the registers) can be saved in the stack when an interrupt is accepted and then restored after the interrupt has been serviced. This ability to save the processor's status at any given time is possible even if an interrupt service routine, itself, is interrupted.

### **Instruction Register and Decoder:**

Every computer has a **Word Length** that is characteristic of that machine. A computer's word length is usually determined by the size of its internal storage elements and interconnecting paths (referred to as **Busses**); for example, a computer whose registers and busses can store and transfer 8 bits of information has a characteristic word length of 8-bits and is referred to as an 8-bit parallel processor. An eight-bit parallel processor generally finds it most efficient to deal with eight-bit binary fields, and the memory associated with such a processor is therefore organized to store eight bits in each addressable memory location. Data and instructions are stored in memory as eight-bit binary numbers, or as numbers that are integral multiples of eight bits: 16 bits, 24 bits, and so on. This characteristic eight-bit field is often referred to as a **Byte**.

Each operation that the processor can perform is identified by a unique byte of data known as an **Instruction**

**Code or Operation Code.** An eight-bit word used as an instruction code can distinguish between 256 alternative actions, more than adequate for most processors.

The processor fetches an instruction in two distinct operations. First, the processor transmits the address in its Program Counter to the memory. Then the memory returns the addressed byte to the processor. The CPU stores this instruction byte in a register known as the **Instruction Register**, and uses it to direct activities during the remainder of the instruction execution.

The mechanism by which the processor translates an instruction code into specific processing actions requires more elaboration than we can here afford. The concept, however, should be intuitively clear to any logic designer. The eight bits stored in the instruction register can be decoded and used to selectively activate one of a number of output lines, in this case up to 256 lines. Each line represents a set of activities associated with execution of a particular instruction code. The enabled line can be combined with selected timing pulses, to develop electrical signals that can then be used to initiate specific actions. This translation of code into action is performed by the **Instruction Decoder** and by the associated control circuitry.

An eight-bit instruction code is often sufficient to specify a particular processing action. There are times, however, when execution of the instruction requires more information than eight bits can convey.

One example of this is when the instruction references a memory location. The basic instruction code identifies the operation to be performed, but cannot specify the object address as well. In a case like this, a two- or three-byte instruction must be used. Successive instruction bytes are stored in sequentially adjacent memory locations, and the processor performs two or three fetches in succession to obtain the full instruction. The first byte retrieved from memory is placed in the processor's instruction register, and subsequent bytes are placed in temporary storage; the processor then proceeds with the execution phase. Such an instruction is referred to as **Variable Length**.

#### **Address Register(s):**

A CPU may use a register or register-pair to hold the address of a memory location that is to be accessed for data. If the address register is **Programmable**, (i.e., if there are instructions that allow the programmer to alter the contents of the register) the program can "build" an address in the address register prior to executing a **Memory Reference** instruction (i.e., an instruction that reads data from memory, writes data to memory or operates on data stored in memory).

#### **Arithmetic/Logic Unit (ALU):**

All processors contain an arithmetic/logic unit, which is often referred to simply as the ALU. The ALU, as its name implies, is that portion of the CPU hardware which

performs the arithmetic and logical operations on the binary data.

The ALU must contain an **Adder** which is capable of combining the contents of two registers in accordance with the logic of binary arithmetic. This provision permits the processor to perform arithmetic manipulations on the data it obtains from memory and from its other inputs.

Using only the basic adder a capable programmer can write routines which will subtract, multiply and divide, giving the machine complete arithmetic capabilities. In practice, however, most ALUs provide other built-in functions, including hardware subtraction, boolean logic operations, and shift capabilities.

The ALU contains **Flag Bits** which specify certain conditions that arise in the course of arithmetic and logical manipulations. Flags typically include **Carry**, **Zero**, **Sign**, and **Parity**. It is possible to program jumps which are conditionally dependent on the status of one or more flags. Thus, for example, the program may be designed to jump to a special routine if the carry bit is set following an addition instruction.

#### **Control Circuitry:**

The control circuitry is the primary functional unit within a CPU. Using clock inputs, the control circuitry maintains the proper sequence of events required for any processing task. After an instruction is fetched and decoded, the control circuitry issues the appropriate signals (to units both internal and external to the CPU) for initiating the proper processing action. Often the control circuitry will be capable of responding to external signals, such as an interrupt or wait request. An **Interrupt** request will cause the control circuitry to temporarily interrupt main program execution, jump to a special routine to service the interrupting device, then automatically return to the main program. A **Wait** request is often issued by a memory or I/O element that operates slower than the CPU. The control circuitry will idle the CPU until the memory or I/O port is ready with the data.

## **COMPUTER OPERATIONS**

There are certain operations that are basic to almost any computer. A sound understanding of these basic operations is a necessary prerequisite to examining the specific operations of a particular computer.

#### **Timing:**

The activities of the central processor are cyclical. The processor fetches an instruction, performs the operations required, fetches the next instruction, and so on. This orderly sequence of events requires precise timing, and the CPU therefore requires a free running oscillator clock which furnishes the reference for all processor actions. The combined fetch and execution of a single instruction is referred to as an **Instruction Cycle**. The portion of a cycle identified

with a clearly defined activity is called a **State**. And the interval between pulses of the timing oscillator is referred to as a **Clock Period**. As a general rule, one or more clock periods are necessary for the completion of a state, and there are several states in a cycle.

### Instruction Fetch:

The first state(s) of any instruction cycle will be dedicated to fetching the next instruction. The CPU issues a read signal and the contents of the program counter are sent to memory, which responds by returning the next instruction word. The first byte of the instruction is placed in the instruction register. If the instruction consists of more than one byte, additional states are required to fetch each byte of the instruction. When the entire instruction is present in the CPU, the program counter is incremented (in preparation for the next instruction fetch) and the instruction is decoded. The operation specified in the instruction will be executed in the remaining states of the instruction cycle. The instruction may call for a memory read or write, an input or output and/or an internal CPU operation, such as a register-to-register transfer or an add-registers operation.

### Memory Read:

An instruction fetch is merely a special memory read operation that brings the instruction to the CPU's instruction register. The instruction fetched may then call for data to be read from memory into the CPU. The CPU again issues a read signal and sends the proper memory address; memory responds by returning the requested word. The data received is placed in the accumulator or one of the other general purpose registers (not the instruction register).

### Memory Write:

A memory write operation is similar to a read except for the direction of data flow. The CPU issues a write signal, sends the proper memory address, then sends the data word to be written into the addressed memory location.

### Wait (memory synchronization):

As previously stated, the activities of the processor are timed by a master clock oscillator. The clock period determines the timing of all processing activity.

The speed of the processing cycle, however, is limited by the memory's **Access Time**. Once the processor has sent a read address to memory, it cannot proceed until the memory has had time to respond. Most memories are capable of responding much faster than the processing cycle requires. A few, however, cannot supply the addressed byte within the minimum time established by the processor's clock.

Therefore a processor should contain a synchronization provision, which permits the memory to request a **Wait state**. When the memory receives a read or write enable signal, it places a request signal on the processor's **READY** line, causing the CPU to idle temporarily. After the memory has

had time to respond, it frees the processor's **READY** line, and the instruction cycle proceeds.

### Input/Output:

Input and Output operations are similar to memory read and write operations with the exception that a peripheral I/O device is addressed instead of a memory location. The CPU issues the appropriate input or output control signal, sends the proper device address and either receives the data being input or sends the data to be output.

Data can be input/output in either parallel or serial form. All data within a digital computer is represented in binary coded form. A binary data word consists of a group of bits; each bit is either a one or a zero. **Parallel I/O** consists of transferring all bits in the word at the same time, one bit per line. **Serial I/O** consists of transferring one bit at a time on a single line. Naturally serial I/O is much slower, but it requires considerably less hardware than does parallel I/O.

### Interrupts:

**Interrupt** provisions are included on many central processors, as a means of improving the processor's efficiency. Consider the case of a computer that is processing a large volume of data, portions of which are to be output to a printer. The CPU can output a byte of data within a single machine cycle but it may take the printer the equivalent of many machine cycles to actually print the character specified by the data byte. The CPU could then remain idle waiting until the printer can accept the next data byte. If an interrupt capability is implemented on the computer, the CPU can output a data byte then return to data processing. When the printer is ready to accept the next data byte, it can request an interrupt. When the CPU acknowledges the interrupt, it suspends main program execution and automatically branches to a routine that will output the next data byte. After the byte is output, the CPU continues with main program execution. Note that this is, in principle, quite similar to a subroutine call, except that the jump is initiated externally rather than by the program.

More complex interrupt structures are possible, in which several interrupting devices share the same processor but have different priority levels. Interruptive processing is an important feature that enables maximum utilization of a processor's capacity for high system throughput.

### Hold:

Another important feature that improves the throughput of a processor is the **Hold**. The hold provision enables **Direct Memory Access (DMA)** operations.

In ordinary input and output operations, the processor itself supervises the entire data transfer. Information to be placed in memory is transferred from the input device to the processor, and then from the processor to the designated memory location. In similar fashion, information that goes

from memory to output devices goes by way of the processor.

Some peripheral devices, however, are capable of transferring information to and from memory much faster than the processor itself can accomplish the transfer. If any appreciable quantity of data must be transferred to or from such a device, then **system throughput** will be increased by

having the device accomplish the transfer directly. The processor must temporarily suspend its operation during such a transfer, to prevent conflicts that would arise if processor and peripheral device attempted to access memory simultaneously. It is for this reason that a **hold** provision is included on some processors.



# CHAPTER 2 THE 8080 CENTRAL PROCESSOR UNIT

The 8080 is a complete 8-bit parallel, central processor unit (CPU) for use in general purpose digital computer systems. It is fabricated on a single LSI chip (see Figure 2-1), using Intel's n-channel silicon gate MOS process. The 8080 transfers data and internal state information via an 8-bit, bidirectional 3-state Data Bus (D<sub>0</sub>-D<sub>7</sub>). Memory and peripheral device addresses are transmitted over a separate 16-

bit 3-state Address Bus (A<sub>0</sub>-A<sub>15</sub>). Six timing and control outputs (SYNC, DBIN, WAIT, WR, HLDA and INTE) emanate from the 8080, while four control inputs (READY, HOLD, INT and RESET), four power inputs (+12V, +5V, -5V, and GND) and two clock inputs ( $\phi_1$  and  $\phi_2$ ) are accepted by the 8080.

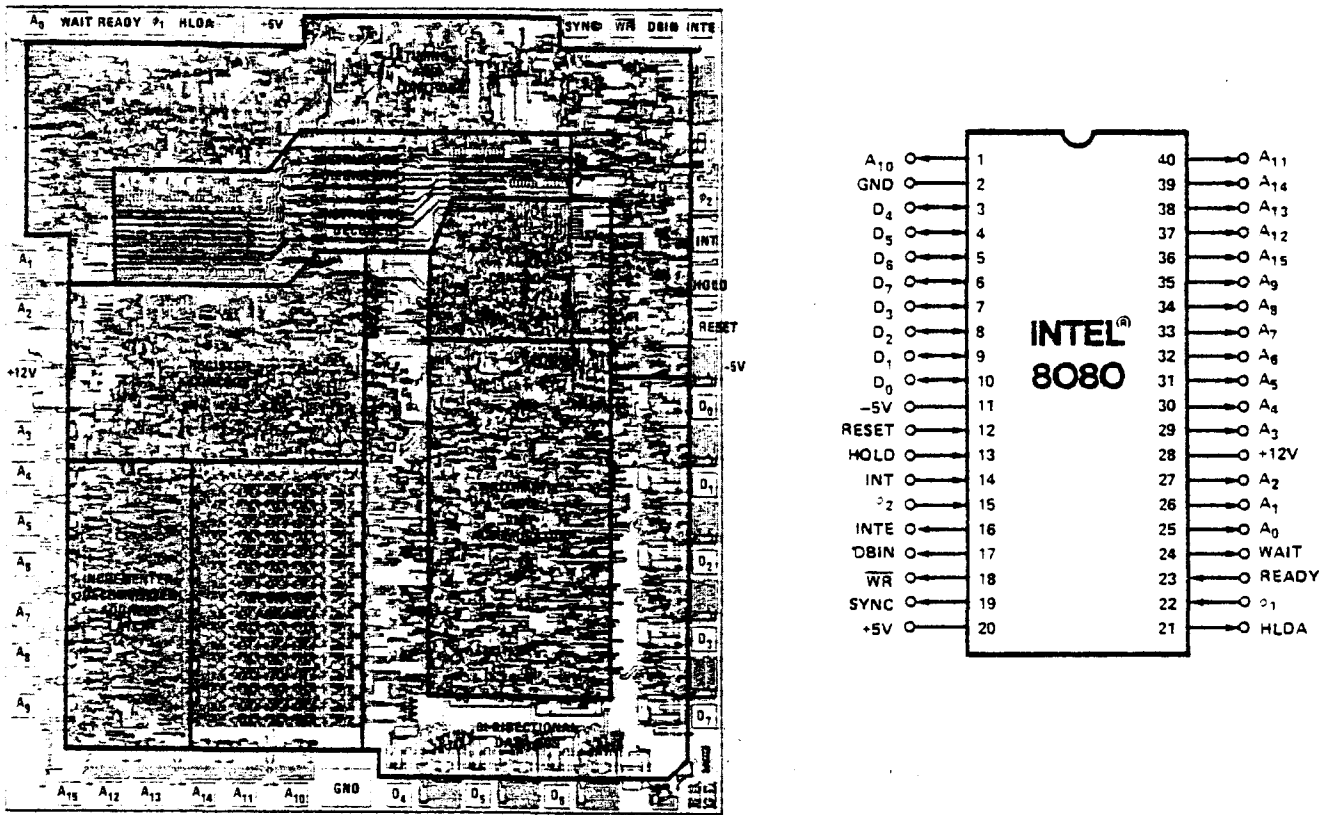

Figure 2-1. 8080 Photomicrograph With Pin Designations

## ARCHITECTURE OF THE 8080 CPU

The 8080 CPU consists of the following functional units:

- Register array and address logic
- Arithmetic and logic unit (ALU)
- Instruction register and control section
- Bi-directional, 3-state data bus buffer

Figure 2-2 illustrates the functional blocks within the 8080 CPU.

### Registers:

The register section consists of a static RAM array organized into six 16-bit registers:

- Program counter (PC)
- Stack pointer (SP)
- Six 8-bit general purpose registers arranged in pairs, referred to as B,C; D,E; and H,L
- A temporary register pair called W,Z

The program counter maintains the memory address of the current program instruction and is incremented auto-

matically during every instruction fetch. The stack pointer maintains the address of the next available stack location in memory. The stack pointer can be initialized to use any portion of read-write memory as a stack. The stack pointer is decremented when data is "pushed" onto the stack and incremented when data is "popped" off the stack (i.e., the stack grows "downward").

The six general purpose registers can be used either as single registers (8-bit) or as register pairs (16-bit). The temporary register pair, W,Z, is not program addressable and is only used for the internal execution of instructions.

Eight-bit data bytes can be transferred between the internal bus and the register array via the register-select multiplexer. Sixteen-bit transfers can proceed between the register array and the address latch or the incrementer/decrementer circuit. The address latch receives data from any of the three register pairs and drives the 16 address output buffers (A<sub>0</sub>-A<sub>15</sub>), as well as the incrementer/decrementer circuit. The incrementer/decrementer circuit receives data from the address latch and sends it to the register array. The 16-bit data can be incremented or decremented or simply transferred between registers.

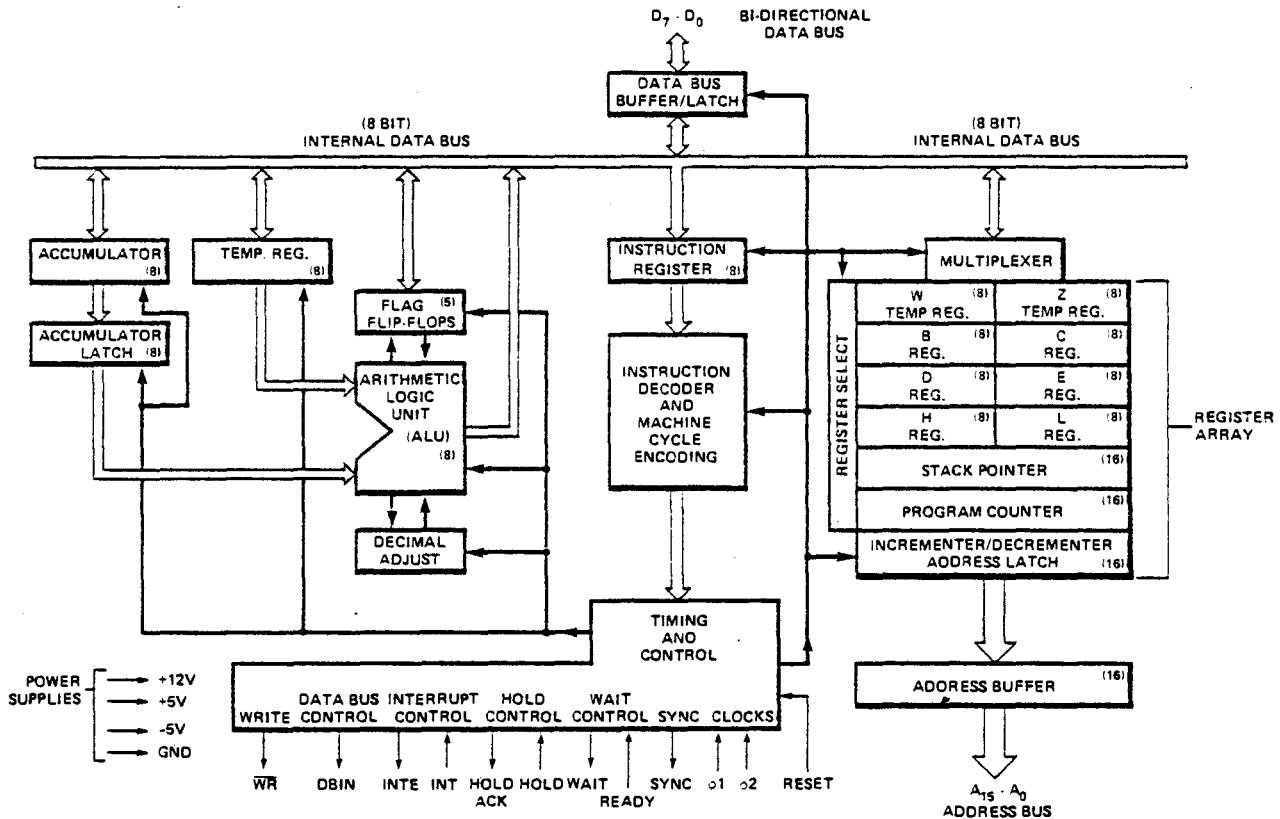

Figure 2-2. 8080 CPU Functional Block Diagram

## Arithmetic and Logic Unit (ALU):

The ALU contains the following registers:

- An 8-bit accumulator
- An 8-bit temporary accumulator (ACT)
- A 5-bit flag register: zero, carry, sign, parity and auxiliary carry
- An 8-bit temporary register (TMP)

Arithmetic, logical and rotate operations are performed in the ALU. The ALU is fed by the temporary register (TMP) and the temporary accumulator (ACT) and carry flip-flop. The result of the operation can be transferred to the internal bus or to the accumulator; the ALU also feeds the flag register.

The temporary register (TMP) receives information from the internal bus and can send all or portions of it to the ALU, the flag register and the internal bus.

The accumulator (ACC) can be loaded from the ALU and the internal bus and can transfer data to the temporary accumulator (ACT) and the internal bus. The contents of the accumulator (ACC) and the auxiliary carry flip-flop can be tested for decimal correction during the execution of the DAA instruction (see Chapter 4).

## Instruction Register and Control:

During an instruction fetch, the first byte of an instruction (containing the OP code) is transferred from the internal bus to the 8-bit instruction register.

The contents of the instruction register are, in turn, available to the instruction decoder. The output of the decoder, combined with various timing signals, provides the control signals for the register array, ALU and data buffer blocks. In addition, the outputs from the instruction decoder and external control signals feed the timing and state control section which generates the state and cycle timing signals.

## Data Bus Buffer:

This 8-bit bidirectional 3-state buffer is used to isolate the CPU's internal bus from the external data bus (D<sub>0</sub> through D<sub>7</sub>). In the output mode, the internal bus content is loaded into an 8-bit latch that, in turn, drives the data bus output buffers. The output buffers are switched off during input or non-transfer operations.

During the input mode, data from the external data bus is transferred to the internal bus. The internal bus is pre-charged at the beginning of each internal state, except for the transfer state (T<sub>3</sub>—described later in this chapter).

## THE PROCESSOR CYCLE

An **instruction cycle** is defined as the time required to fetch and execute an instruction. During the fetch, a selected instruction (one, two or three bytes) is extracted from memory and deposited in the CPU's instruction register. During the execution phase, the instruction is decoded and translated into specific processing activities.

Every instruction cycle consists of one, two, three, four or five machine cycles. A **machine cycle** is required each time the CPU accesses memory or an I/O port. The fetch portion of an instruction cycle requires one machine cycle for each byte to be fetched. The duration of the execution portion of the instruction cycle depends on the kind of instruction that has been fetched. Some instructions do not require any machine cycles other than those necessary to fetch the instruction; other instructions, however, require additional machine cycles to write or read data to/from memory or I/O devices. The DAD instruction is an exception in that it requires two additional machine cycles to complete an internal register-pair add (see Chapter 4).

Each machine cycle consists of three, four or five states. A state is the smallest unit of processing activity and is defined as the interval between two successive positive-going transitions of the  $\phi_1$  driven clock pulse. The 8080 is driven by a two-phase clock oscillator. All processing activities are referred to the period of this clock. The two non-overlapping clock pulses, labeled  $\phi_1$  and  $\phi_2$ , are furnished by external circuitry. It is the  $\phi_1$  clock pulse which divides each machine cycle into states. Timing logic within the 8080 uses the clock inputs to produce a SYNC pulse, which identifies the beginning of every machine cycle. The SYNC pulse is triggered by the low-to-high transition of  $\phi_2$ , as shown in Figure 2-3.

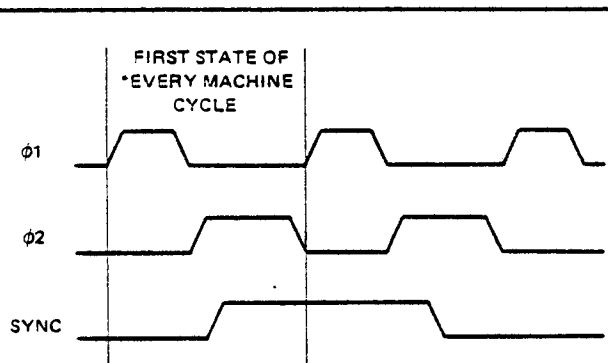

\*SYNC DOES NOT OCCUR IN THE SECOND AND THIRD MACHINE CYCLES OF A DAD INSTRUCTION SINCE THESE MACHINE CYCLES ARE USED FOR AN INTERNAL REGISTER-PAIR ADD.

Figure 2-3.  $\phi_1$ ,  $\phi_2$  And SYNC Timing

There are three exceptions to the defined duration of a state. They are the WAIT state, the hold (HLDA) state and the halt (HLTA) state, described later in this chapter. Because the WAIT, the HLDA, and the HLTA states depend upon external events, they are by their nature of indeterminate length. Even these exceptional states, however, must

be synchronized with the pulses of the driving clock. Thus, the duration of all states are integral multiples of the clock period.

To summarize then, each clock period marks a state; three to five states constitute a machine cycle; and one to five machine cycles comprise an instruction cycle. A full instruction cycle requires anywhere from four to eighteen states for its completion, depending on the kind of instruction involved.

### Machine Cycle Identification:

With the exception of the DAD instruction, there is just one consideration that determines how many machine cycles are required in any given instruction cycle: the number of times that the processor must reference a memory address or an addressable peripheral device, in order to fetch and execute the instruction. Like many processors, the 8080 is so constructed that it can transmit only one address per machine cycle. Thus, if the fetch and execution of an instruction requires two memory references, then the instruction cycle associated with that instruction consists of two machine cycles. If five such references are called for, then the instruction cycle contains five machine cycles.

Every instruction cycle has at least one reference to memory, during which the instruction is fetched. An instruction cycle must always have a fetch, even if the execution of the instruction requires no further references to memory. The first machine cycle in every instruction cycle is therefore a FETCH. Beyond that, there are no fast rules. It depends on the kind of instruction that is fetched.

Consider some examples. The add-register (ADD r) instruction is an instruction that requires only a single machine cycle (FETCH) for its completion. In this one-byte instruction, the contents of one of the CPU's six general purpose registers is added to the existing contents of the accumulator. Since all the information necessary to execute the command is contained in the eight bits of the instruction code, only one memory reference is necessary. Three states are used to extract the instruction from memory, and one additional state is used to accomplish the desired addition. The entire instruction cycle thus requires only one machine cycle that consists of four states, or four periods of the external clock.

Suppose now, however, that we wish to add the contents of a specific memory location to the existing contents of the accumulator (ADD M). Although this is quite similar in principle to the example just cited, several additional steps will be used. An extra machine cycle will be used, in order to address the desired memory location.

The actual sequence is as follows. First the processor extracts from memory the one-byte instruction word addressed by its program counter. This takes three states. The eight-bit instruction word obtained during the FETCH machine cycle is deposited in the CPU's instruction register and used to direct activities during the remainder of the instruction cycle. Next, the processor sends out, as an address,

the contents of its H and L registers. The eight-bit data word returned during this MEMORY READ machine cycle is placed in a temporary register inside the 8080 CPU. By now three more clock periods (states) have elapsed. In the seventh and final state, the contents of the temporary register are added to those of the accumulator. Two machine cycles, consisting of seven states in all, complete the "ADD M" instruction cycle.

At the opposite extreme is the save H and L registers (SHLD) instruction, which requires five machine cycles. During an "SHLD" instruction cycle, the contents of the processor's H and L registers are deposited in two sequentially adjacent memory locations; the destination is indicated by two address bytes which are stored in the two memory locations immediately following the operation code byte. The following sequence of events occurs:

- (1) A FETCH machine cycle, consisting of four states. During the first three states of this machine cycle, the processor fetches the instruction indicated by its program counter. The program counter is then incremented. The fourth state is used for internal instruction decoding.
- (2) A MEMORY READ machine cycle, consisting of three states. During this machine cycle, the byte indicated by the program counter is read from memory and placed in the processor's Z register. The program counter is incremented again.
- (3) Another MEMORY READ machine cycle, consisting of three states, in which the byte indicated by the processor's program counter is read from memory and placed in the W register. The program counter is incremented, in anticipation of the next instruction fetch.
- (4) A MEMORY WRITE machine cycle, of three states, in which the contents of the L register are transferred to the memory location pointed to by the present contents of the W and Z registers. The state following the transfer is used to increment the W,Z register pair so that it indicates the next memory location to receive data.
- (5) A MEMORY WRITE machine cycle, of three states, in which the contents of the H register are transferred to the new memory location pointed to by the W,Z register pair.

In summary, the "SHLD" instruction cycle contains five machine cycles and takes 16 states to execute.

Most instructions fall somewhere between the extremes typified by the "ADD r" and the "SHLD" instructions. The input (INP) and the output (OUT) instructions, for example, require three machine cycles: a FETCH, to obtain the instruction; a MEMORY READ, to obtain the address of the object peripheral; and an INPUT or an OUTPUT machine cycle, to complete the transfer.

While no one instruction cycle will consist of more than five machine cycles, the following ten different types of machine cycles may occur within an instruction cycle:

- (1) FETCH (M1)
- (2) MEMORY READ
- (3) MEMORY WRITE
- (4) STACK READ
- (5) STACK WRITE
- (6) INPUT
- (7) OUTPUT
- (8) INTERRUPT
- (9) HALT
- (10) HALT • INTERRUPT

The machine cycles that actually do occur in a particular instruction cycle depend upon the kind of instruction, with the overriding stipulation that the first machine cycle in any instruction cycle is always a FETCH.

The processor identifies the machine cycle in progress by transmitting an eight-bit status word during the first state of every machine cycle. Updated status information is presented on the 8080's data lines (D<sub>0</sub>-D<sub>7</sub>), during the SYNC interval. This data should be saved in latches, and used to develop control signals for external circuitry. Table 2-1 shows how the positive-true status information is distributed on the processor's data bus.

Status signals are provided principally for the control of external circuitry. Simplicity of interface, rather than machine cycle identification, dictates the logical definition of individual status bits. You will therefore observe that certain processor machine cycles are uniquely identified by a single status bit, but that others are not. The M<sub>1</sub> status bit (D<sub>6</sub>), for example, unambiguously identifies a FETCH machine cycle. A STACK READ, on the other hand, is indicated by the coincidence of STACK and MEMR signals. Machine cycle identification data is also valuable in the test and de-bugging phases of system development. Table 2-1 lists the status bit outputs for each type of machine cycle.

### State Transition Sequence:

Every machine cycle within an instruction cycle consists of three to five active states (referred to as T<sub>1</sub>, T<sub>2</sub>, T<sub>3</sub>, T<sub>4</sub>, T<sub>5</sub> or T<sub>W</sub>). The actual number of states depends upon the instruction being executed, and on the particular machine cycle within the greater instruction cycle. The state transition diagram in Figure 2-4 shows how the 8080 proceeds from state to state in the course of a machine cycle. The diagram also shows how the READY, HOLD, and INTERRUPT lines are sampled during the machine cycle, and how the conditions on these lines may modify the

basic transition sequence. In the present discussion, we are concerned only with the basic sequence and with the READY function. The HOLD and INTERRUPT functions will be discussed later.

The 8080 CPU does not directly indicate its internal state by transmitting a "state control" output during each state; instead, the 8080 supplies direct control output (INTE, HLDA, DBIN, WR and WAIT) for use by external circuitry.

Recall that the 8080 passes through at least three states in every machine cycle, with each state defined by successive low-to-high transitions of the  $\phi_1$  clock. Figure 2-5 shows the timing relationships in a typical FETCH machine cycle. Events that occur in each state are referenced to transitions of the  $\phi_1$  and  $\phi_2$  clock pulses.

The SYNC signal identifies the first state (T<sub>1</sub>) in every machine cycle. As shown in Figure 2-5, the SYNC signal is related to the leading edge of the  $\phi_2$  clock. There is a delay (t<sub>DC</sub>) between the low-to-high transition of  $\phi_2$  and the positive-going edge of the SYNC pulse. There also is a corresponding delay (also t<sub>DC</sub>) between the next  $\phi_2$  pulse and the falling edge of the SYNC signal. Status information is displayed on D<sub>0</sub>-D<sub>7</sub> during the same  $\phi_2$  to  $\phi_2$  interval. Switching of the status signals is likewise controlled by  $\phi_2$ .

The rising edge of  $\phi_2$  during T<sub>1</sub> also loads the processor's address lines (A<sub>0</sub>-A<sub>15</sub>). These lines become stable within a brief delay (t<sub>DA</sub>) of the  $\phi_2$  clocking pulse, and they remain stable until the first  $\phi_2$  pulse after state T<sub>3</sub>. This gives the processor ample time to read the data returned from memory.

Once the processor has sent an address to memory, there is an opportunity for the memory to request a WAIT. This it does by pulling the processor's READY line low, prior to the "Ready set-up" interval (t<sub>RS</sub>) which occurs during the  $\phi_2$  pulse within state T<sub>2</sub> or T<sub>W</sub>. As long as the READY line remains low, the processor will idle, giving the memory time to respond to the addressed data request. Refer to Figure 2-5.

The processor responds to a wait request by entering an alternative state (T<sub>W</sub>) at the end of T<sub>2</sub>, rather than proceeding directly to the T<sub>3</sub> state. Entry into the T<sub>W</sub> state is indicated by a WAIT signal from the processor, acknowledging the memory's request. A low-to-high transition on the WAIT line is triggered by the rising edge of the  $\phi_1$  clock and occurs within a brief delay (t<sub>DC</sub>) of the actual entry into the T<sub>W</sub> state.

A wait period may be of indefinite duration. The processor remains in the waiting condition until its READY line again goes high. A READY indication must precede the falling edge of the  $\phi_2$  clock by a specified interval (t<sub>RS</sub>), in order to guarantee an exit from the T<sub>W</sub> state. The cycle may then proceed, beginning with the rising edge of the next  $\phi_1$  clock. A WAIT interval will therefore consist of an integral number of T<sub>W</sub> states and will always be a multiple of the clock period.

Instructions for the 8080 require from one to five machine cycles for complete execution. The 8080 sends out 8 bit of status information on the data bus at the beginning of each machine cycle (during SYNC time). The following table defines the status information.

**STATUS INFORMATION DEFINITION**

| Symbols         | Bit            | Definition   |
|-----------------|----------------|--|
| INTA*           | D <sub>0</sub> | Acknowledge signal for INTERRUPT request. Signal should be used to gate a restart instruction onto the data bus when DBIN is active.   |
| $\overline{WO}$ | D <sub>1</sub> | Indicates that the operation in the current machine cycle will be a WRITE memory or OUTPUT function ( $\overline{WO} = 0$ ). Otherwise, a READ memory or INPUT operation will be executed. |
| STACK           | D <sub>2</sub> | Indicates that the address bus holds the pushdown stack address from the Stack Pointer.  |
| HLTA            | D <sub>3</sub> | Acknowledge signal for HALT instruction.   |
| OUT             | D <sub>4</sub> | Indicates that the address bus contains the address of an output device and the data bus will contain the output data when $\overline{WR}$ is active.                                      |
| M <sub>1</sub>  | D <sub>5</sub> | Provides a signal to indicate that the CPU is in the fetch cycle for the first byte of an instruction.   |
| INP*            | D <sub>6</sub> | Indicates that the address bus contains the address of an input device and the input data should be placed on the data bus when DBIN is active.  |
| MEMR*           | D <sub>7</sub> | Designates that the data bus will be used for memory read data.  |

\*These three status bits can be used to control the flow of data onto the 8080 data bus.

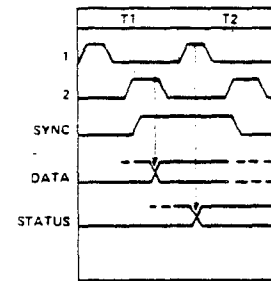
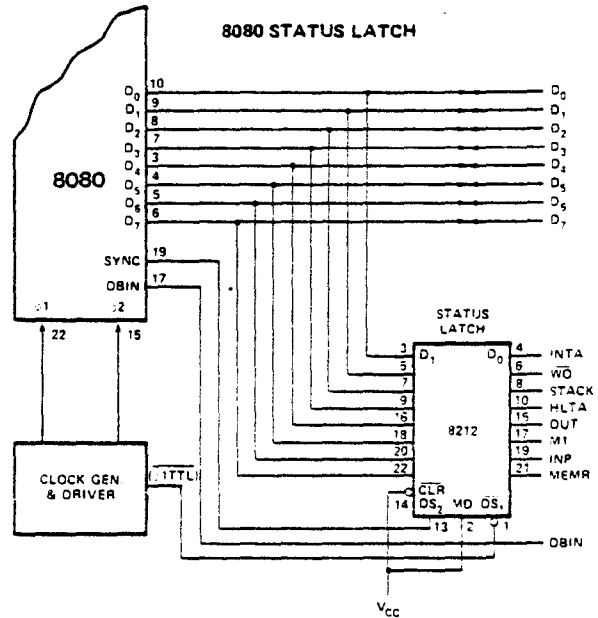

**STATUS WORD CHART**

| DATA BUS BIT   | STATUS INFORMATION | TYPE OF MACHINE CYCLE |   |   |   |   |   |   |   |   |   |
|----------------|--------------------|-----------------------|---|---|---|---|---|---|---|---|---|
|                |                    | ①                     | ② | ③ | ④ | ⑤ | ⑥ | ⑦ | ⑧ | ⑨ | ⑩ |
| D <sub>0</sub> | INTA               | 0                     | 0 | 0 | 0 | 0 | 0 | 0 | 1 | 0 | 1 |
| D <sub>1</sub> | $\overline{WO}$    | 1                     | 1 | 0 | 1 | 0 | 1 | 0 | 1 | 1 | 1 |
| D <sub>2</sub> | STACK              | 0                     | 0 | 0 | 1 | 1 | 0 | 0 | 0 | 0 | 0 |
| D <sub>3</sub> | HLTA               | 0                     | 0 | 0 | 0 | 0 | 0 | 0 | 0 | 1 | 1 |
| D <sub>4</sub> | OUT                | 0                     | 0 | 0 | 0 | 0 | 0 | 1 | 0 | 0 | 0 |
| D <sub>5</sub> | M <sub>1</sub>     | 1                     | 0 | 0 | 0 | 0 | 0 | 0 | 1 | 0 | 1 |
| D <sub>6</sub> | INP                | 0                     | 0 | 0 | 0 | 0 | 1 | 0 | 0 | 0 | 0 |
| D <sub>7</sub> | MEMR               | 1                     | 1 | 0 | 1 | 0 | 0 | 0 | 0 | 1 | 0 |

⑩ STATUS WORD

Table 2-1. 8080 Status Bit Definitions

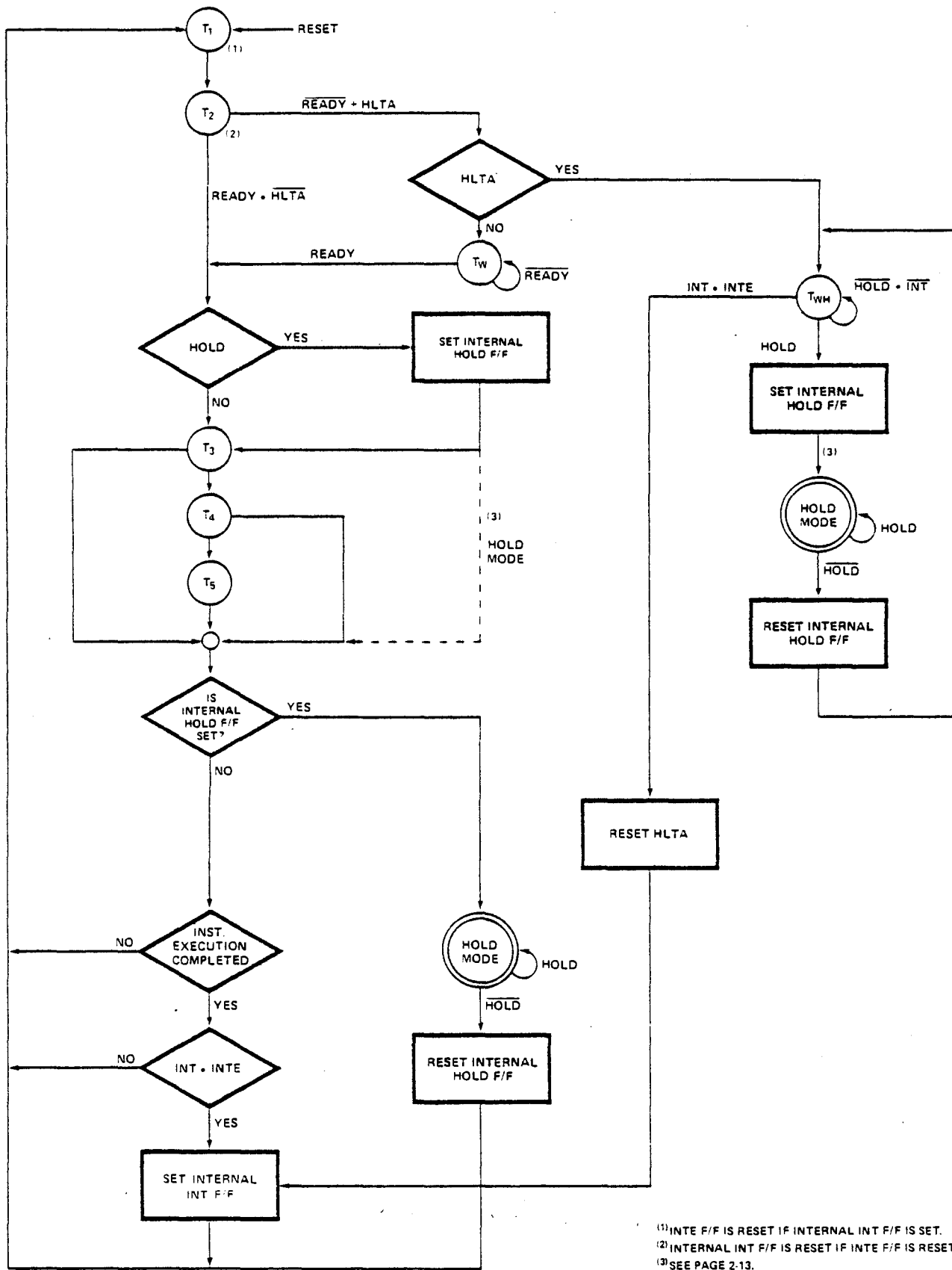

(1) INTE F/F IS RESET IF INTERNAL INT F/F IS SET.  
 (2) INTERNAL INT F/F IS RESET IF INTE F/F IS RESET.  
 (3) SEE PAGE 2-13.

Figure 2-4. CPU State Transition Diagram

The events that take place during the T<sub>3</sub> state are determined by the kind of machine cycle in progress. In a FETCH machine cycle, the processor interprets the data on its data bus as an instruction. During a MEMORY READ or a STACK READ, data on this bus is interpreted as a data word. The processor outputs data on this bus during a MEMORY WRITE machine cycle. During I/O operations, the processor may either transmit or receive data, depending on whether an OUTPUT or an INPUT operation is involved.

Figure 2-6 illustrates the timing that is characteristic of a data input operation. As shown, the low-to-high transition of  $\phi_2$  during T<sub>2</sub> clears status information from the processor's data lines, preparing these lines for the receipt of incoming data. The data presented to the processor must have stabilized prior to both the " $\phi_1$ -data set-up" interval ( $t_{DS1}$ ), that precedes the falling edge of the  $\phi_1$  pulse defining state T<sub>3</sub>, and the " $\phi_2$ -data set-up" interval ( $t_{DS2}$ ), that precedes the rising edge of  $\phi_2$  in state T<sub>3</sub>. This same

data must remain stable during the "data hold" interval ( $t_{DH}$ ) that occurs following the rising edge of the  $\phi_2$  pulse. Data placed on these lines by memory or by other external devices will be sampled during T<sub>3</sub>.

During the input of data to the processor, the 8080 generates a DBIN signal which should be used externally to enable the transfer. Machine cycles in which DBIN is available include: FETCH, MEMORY READ, STACK READ, and INTERRUPT. DBIN is initiated by the rising edge of  $\phi_2$  during state T<sub>2</sub> and terminated by the corresponding edge of  $\phi_2$  during T<sub>3</sub>. Any T<sub>W</sub> phases intervening between T<sub>2</sub> and T<sub>3</sub> will therefore extend DBIN by one or more clock periods.

Figure 2-7 shows the timing of a machine cycle in which the processor outputs data. Output data may be destined either for memory or for peripherals. The rising edge of  $\phi_2$  within state T<sub>2</sub> clears status information from the CPU's data lines, and loads in the data which is to be output to external devices. This substitution takes place within the

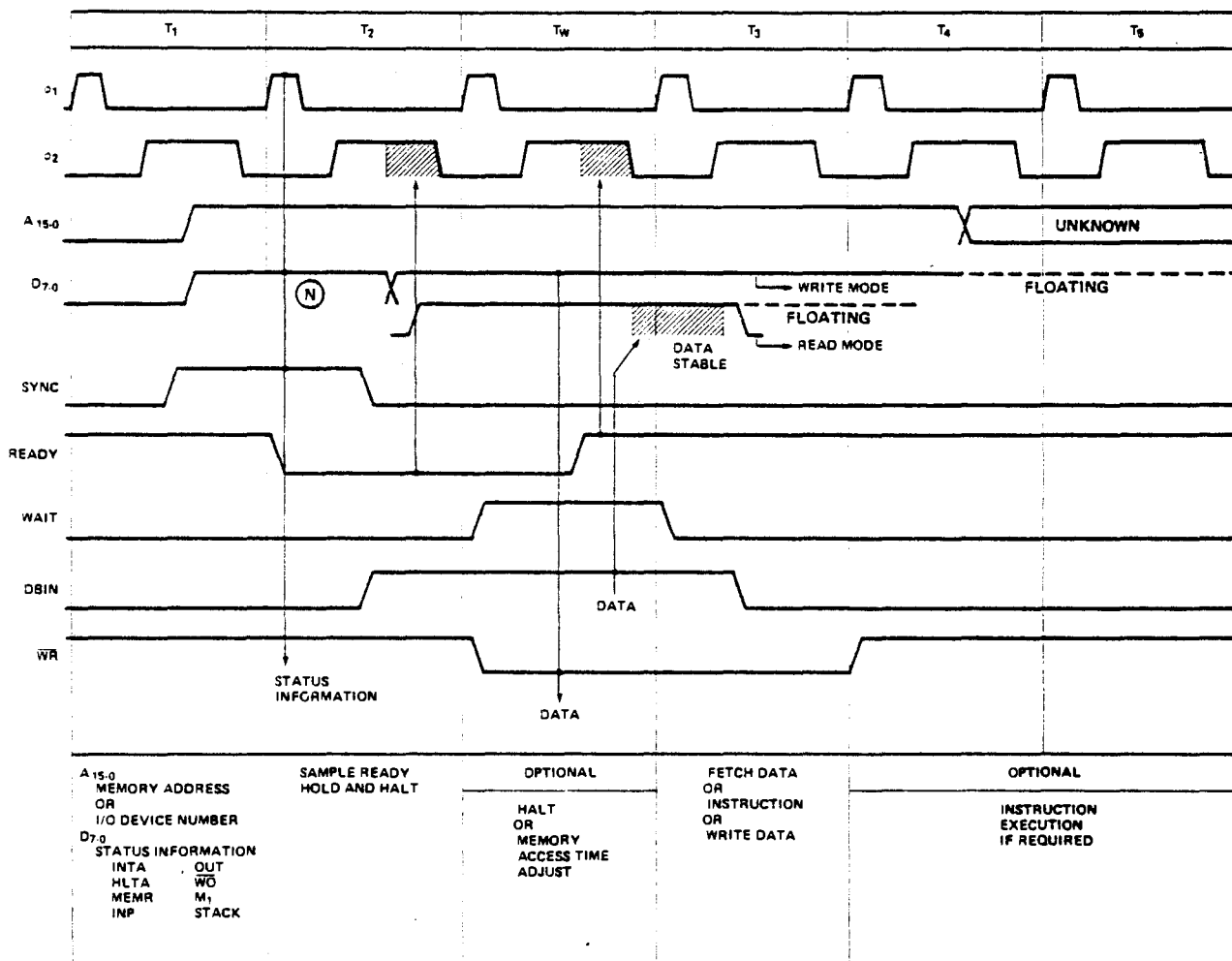

NOTE: (N) Refer to Status Word Chart on Page 2-6.

Figure 2-5. Basic 8080 Instruction Cycle



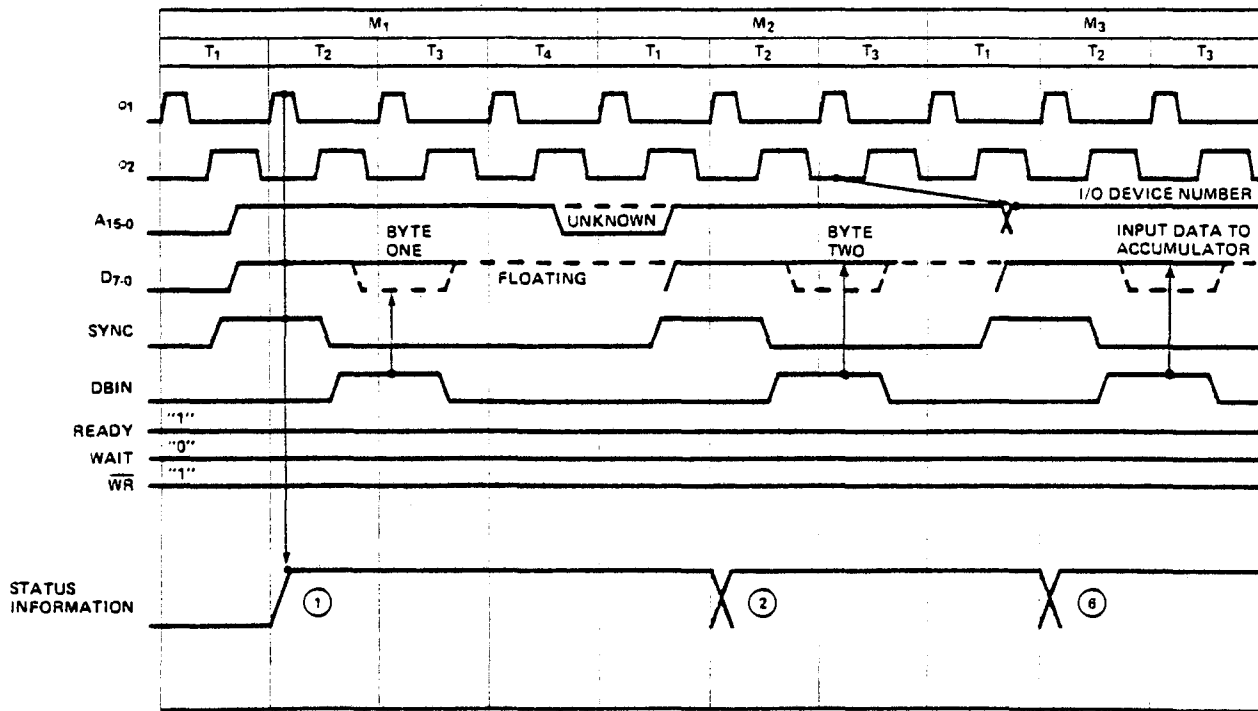

NOTE: (N) Refer to Status Word Chart on Page 2-6.

Figure 2-6. Input Instruction Cycle

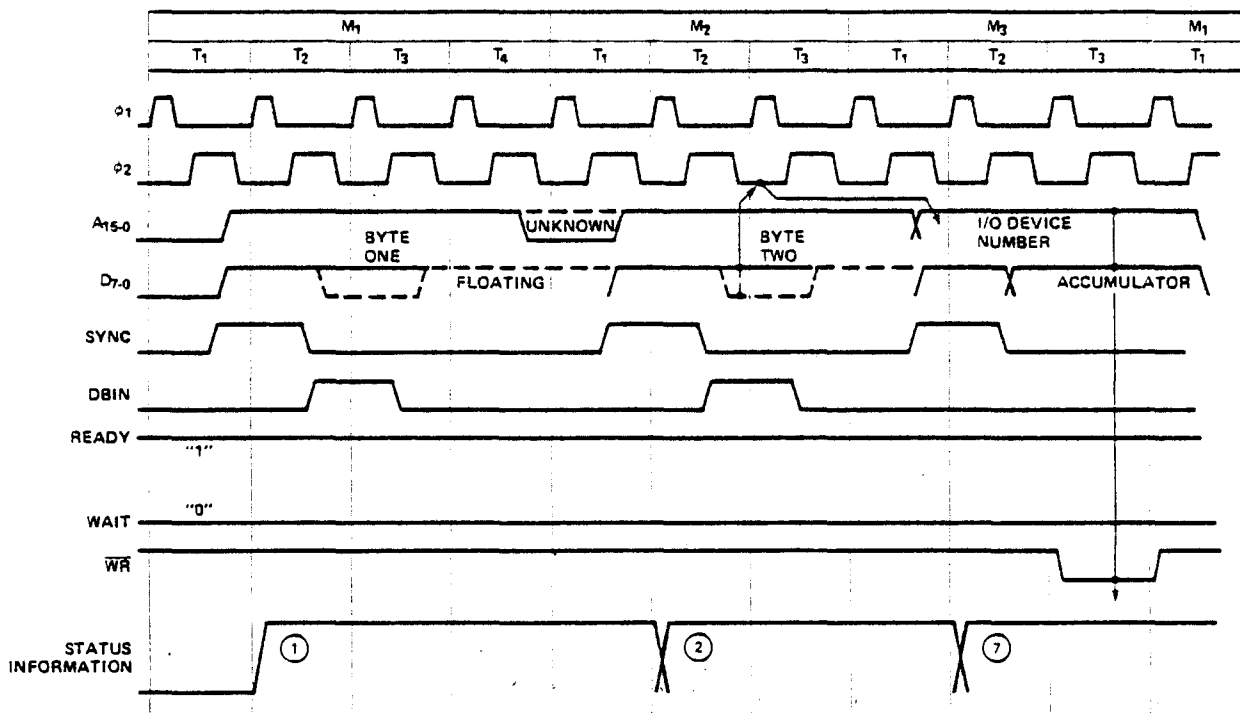

NOTE: (N) Refer to Status Word Chart on Page 2-6.

Figure 2-7. Output Instruction Cycle

“data output delay” interval ( $t_{DD}$ ) following the  $\phi_2$  clock’s leading edge. Data on the bus remains stable throughout the remainder of the machine cycle, until replaced by updated status information in the subsequent  $T_1$  state. Observe that a READY signal is necessary for completion of an OUTPUT machine cycle. Unless such an indication is present, the processor enters the  $T_W$  state, following the  $T_2$  state. Data on the output lines remains stable in the interim, and the processing cycle will not proceed until the READY line again goes high.

The 8080 CPU generates a  $\overline{WR}$  output for the synchronization of external transfers, during those machine cycles in which the processor outputs data. These include MEMORY WRITE, STACK WRITE, and OUTPUT. The negative-going leading edge of  $\overline{WR}$  is referenced to the rising edge of the first  $\phi_1$  clock pulse following  $T_2$ , and occurs within a brief delay ( $t_{DC}$ ) of that event.  $\overline{WR}$  remains low until re-triggered by the leading edge of  $\phi_1$  during the state following  $T_3$ . Note that any  $T_W$  states intervening between  $T_2$  and  $T_3$  of the output machine cycle will neces-

sarily extend  $\overline{WR}$ , in much the same way that  $\overline{DBIN}$  is affected during data input operations.

All processor machine cycles consist of at least three states:  $T_1$ ,  $T_2$ , and  $T_3$  as just described. If the processor has to wait for a response from the peripheral or memory with which it is communicating, then the machine cycle may also contain one or more  $T_W$  states. During the three basic states, data is transferred to or from the processor.

After the  $T_3$  state, however, it becomes difficult to generalize.  $T_4$  and  $T_5$  states are available, if the execution of a particular instruction requires them. But not all machine cycles make use of these states. It depends upon the kind of instruction being executed, and on the particular machine cycle within the instruction cycle. The processor will terminate any machine cycle as soon as its processing activities are completed, rather than proceeding through the  $T_4$  and  $T_5$  states every time. Thus the 8080 may exit a machine cycle following the  $T_3$ , the  $T_4$ , or the  $T_5$  state and proceed directly to the  $T_1$  state of the next machine cycle.

| STATE                        | ASSOCIATED ACTIVITIES  |
|------------------------------|--|
| $T_1$                        | A memory address or I/O device number is placed on the Address Bus (A <sub>15-0</sub> ); status information is placed on Data Bus (D <sub>7-0</sub> ).   |
| $T_2$                        | The CPU samples the READY and HOLD inputs and checks for halt instruction.   |
| $T_W$<br>(optional)          | Processor enters wait state if READY is low or if HALT instruction has been executed.  |
| $T_3$                        | An instruction byte (FETCH machine cycle), data byte (MEMORY READ, STACK READ) or interrupt instruction (INTERRUPT machine cycle) is input to the CPU from the Data Bus; or a data byte (MEMORY WRITE, STACK WRITE or OUTPUT machine cycle) is output onto the data bus. |
| $T_4$<br>$T_5$<br>(optional) | States $T_4$ and $T_5$ are available if the execution of a particular instruction requires them; if not, the CPU may skip one or both of them. $T_4$ and $T_5$ are only used for internal processor operations.  |

Table 2-2. State Definitions

## INTERRUPT SEQUENCES

The 8080 has the built-in capacity to handle external interrupt requests. A peripheral device can initiate an interrupt simply by driving the processor's interrupt (INT) line high.

The interrupt (INT) input is asynchronous, and a request may therefore originate at any time during any instruction cycle. Internal logic re-clocks the external request, so that a proper correspondence with the driving clock is established. As Figure 2-8 shows, an interrupt request (INT) arriving during the time that the interrupt enable line (INTE) is high, acts in coincidence with the  $\phi_2$  clock to set the internal interrupt latch. This event takes place during the last state of the instruction cycle in which the request occurs, thus ensuring that any instruction in progress is completed before the interrupt can be processed.

The INTERRUPT machine cycle which follows the arrival of an enabled interrupt request resembles an ordinary FETCH machine cycle in most respects. The  $M_1$  status bit is transmitted as usual during the SYNC interval. It is accompanied, however, by an INTA status bit ( $D_0$ ) which acknowledges the external request. The contents of the program counter are latched onto the CPU's address lines during  $T_1$ , but the counter itself is not incremented during the INTERRUPT machine cycle, as it otherwise would be.

In this way, the pre-interrupt status of the program counter is preserved, so that data in the counter may be restored by the interrupted program after the interrupt request has been processed.

The interrupt cycle is otherwise indistinguishable from an ordinary FETCH machine cycle. The processor itself takes no further special action. It is the responsibility of the peripheral logic to see that an eight-bit interrupt instruction is "jammed" onto the processor's data bus during state  $T_3$ . In a typical system, this means that the data-in bus from memory must be temporarily disconnected from the processor's main data bus, so that the interrupting device can command the main bus without interference.

The 8080's instruction set provides a special one-byte call which facilitates the processing of interrupts (the ordinary program Call takes three bytes). This is the RESTART instruction (RST). A variable three-bit field embedded in the eight-bit field of the RST enables the interrupting device to direct a Call to one of eight fixed memory locations. The decimal addresses of these dedicated locations are: 0, 8, 16, 24, 32, 40, 48, and 56. Any of these addresses may be used to store the first instruction(s) of a routine designed to service the requirements of an interrupting device. Since the (RST) is a call, completion of the instruction also stores the old program counter contents on the STACK.

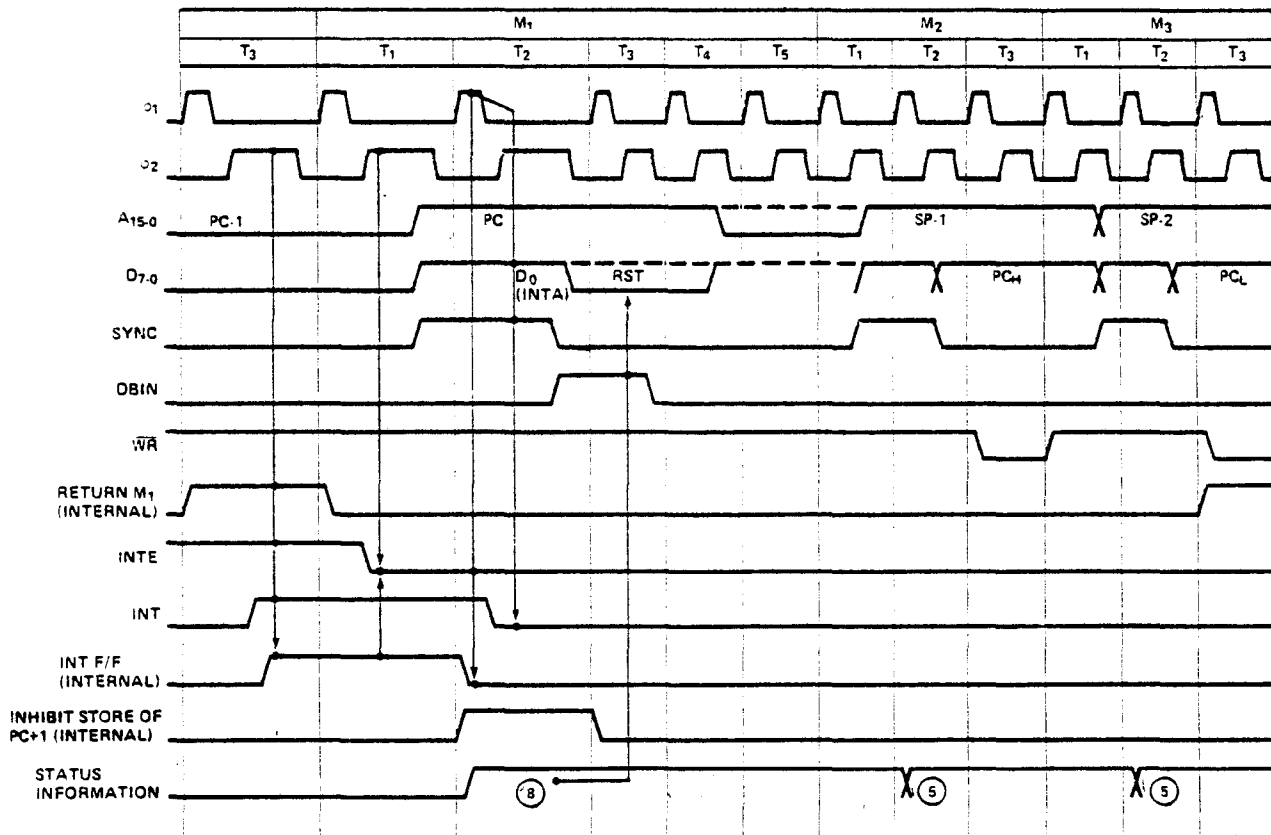

NOTE: (N) Refer to Status Word Chart on Page 2-6.

Figure 2-8. Interrupt Timing

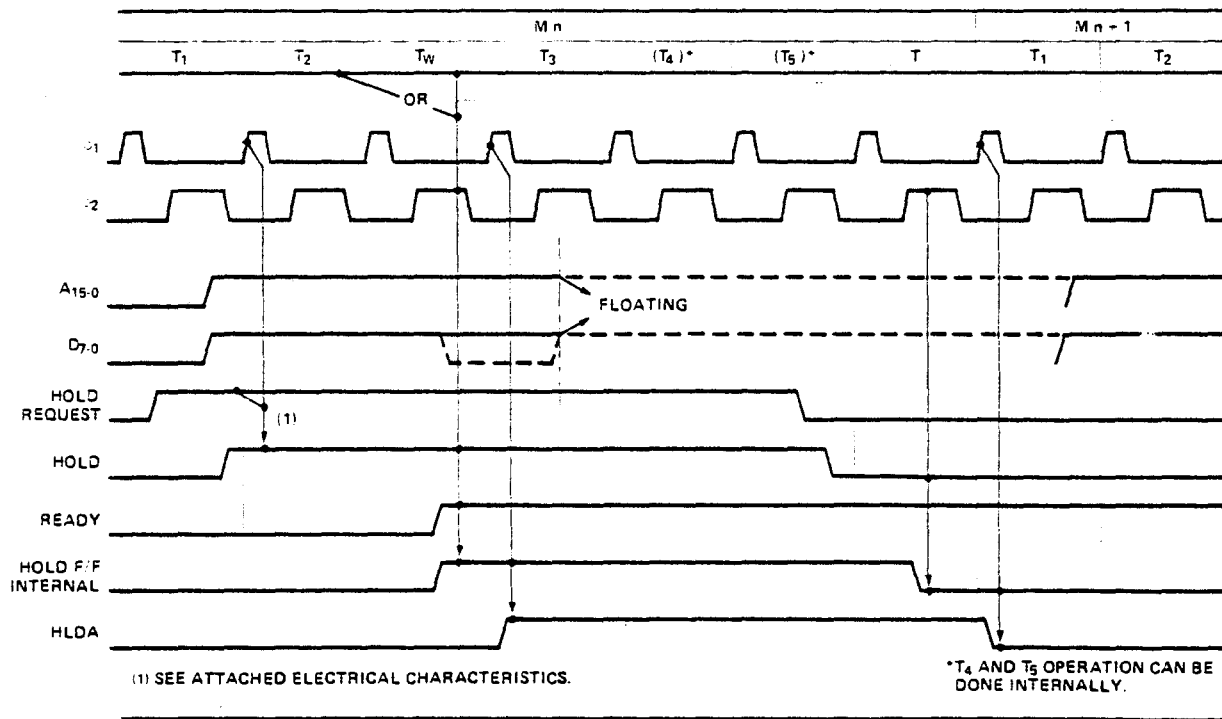

Figure 2-9. HOLD Operation (Read Mode)

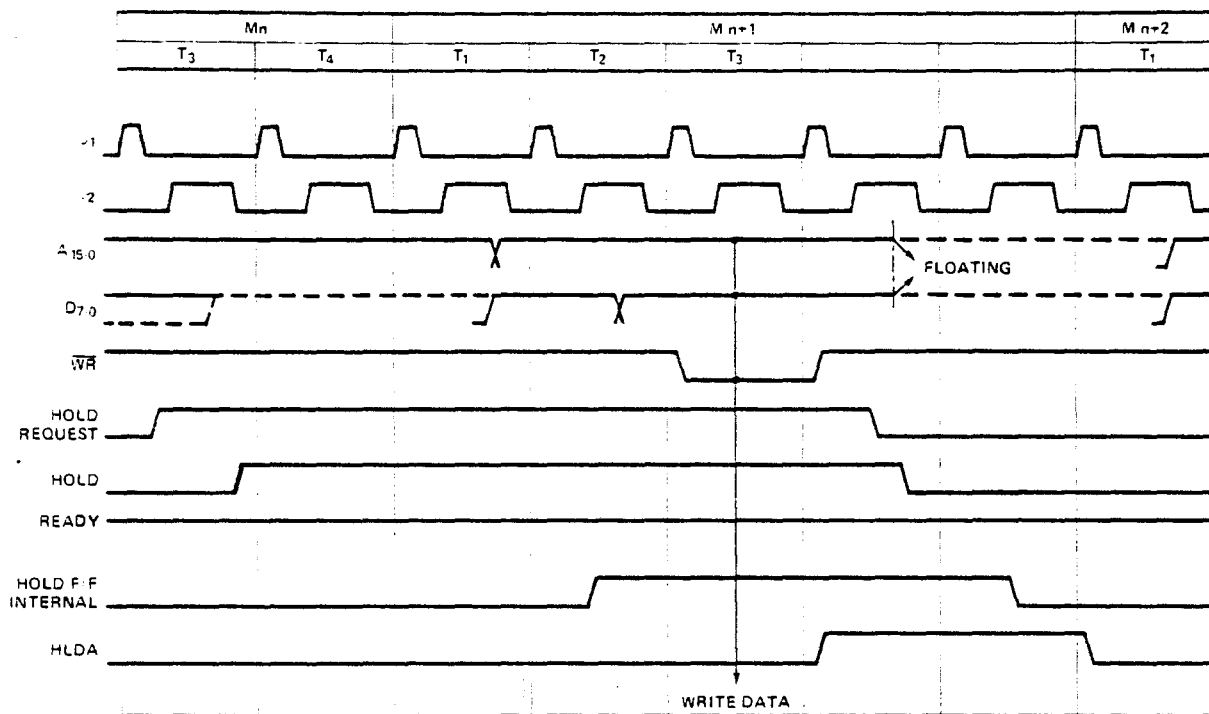

Figure 2-10. HOLD Operation (Write Mode)

## HOLD SEQUENCES

The 8080A CPU contains provisions for Direct Memory Access (DMA) operations. By applying a HOLD to the appropriate control pin on the processor, an external device can cause the CPU to suspend its normal operations and relinquish control of the address and data busses. The processor responds to a request of this kind by floating its address to other devices sharing the busses. At the same time, the processor acknowledges the HOLD by placing a high on its HLDA output pin. During an acknowledged HOLD, the address and data busses are under control of the peripheral which originated the request, enabling it to conduct memory transfers without processor intervention.

Like the interrupt, the HOLD input is synchronized internally. A HOLD signal must be stable prior to the "Hold set-up" interval ( $t_{HS}$ ), that precedes the rising edge of  $\phi_2$ .

Figures 2-9 and 2-10 illustrate the timing involved in HOLD operations. Note the delay between the asynchronous HOLD REQUEST and the re-clocked HOLD. As shown in the diagram, a coincidence of the READY, the HOLD, and the  $\phi_2$  clocks sets the internal hold latch. Setting the latch enables the subsequent rising edge of the  $\phi_1$  clock pulse to trigger the HLDA output.

Acknowledgement of the HOLD REQUEST precedes slightly the actual floating of the processor's address and data lines. The processor acknowledges a HOLD at the beginning of  $T_3$ , if a read or an input machine cycle is in progress (see Figure 2-9). Otherwise, acknowledgement is deferred until the beginning of the state following  $T_3$  (see Figure 2-10). In both cases, however, the HLDA goes high within a specified delay ( $t_{DC}$ ) of the rising edge of the selected  $\phi_1$  clock pulse. Address and data lines are floated within a brief delay after the rising edge of the next  $\phi_2$  clock pulse. This relationship is also shown in the diagrams.

To all outward appearances, the processor has suspended its operations once the address and data busses are floated. Internally, however, certain functions may continue. If a HOLD REQUEST is acknowledged at  $T_3$ , and if the processor is in the middle of a machine cycle which requires four or more states to complete, the CPU proceeds through  $T_4$  and  $T_5$  before coming to a rest. Not until the end of the machine cycle is reached will processing activities cease. Internal processing is thus permitted to overlap the external DMA transfer, improving both the efficiency and the speed of the entire system.

The processor exits the holding state through a sequence similar to that by which it entered. A HOLD REQUEST is terminated asynchronously when the external device has completed its data transfer. The HLDA output

returns to a low level following the leading edge of the next  $\phi_1$  clock pulse. Normal processing resumes with the machine cycle following the last cycle that was executed.

## HALT SEQUENCES

When a halt instruction (HLT) is executed, the CPU enters the halt state ( $T_{WH}$ ) after state  $T_2$  of the next machine cycle, as shown in Figure 2-11. There are only three ways in which the 8080 can exit the halt state:

- A high on the RESET line will always reset the 8080 to state  $T_1$ ; RESET also clears the program counter.
- A HOLD input will cause the 8080 to enter the hold state, as previously described. When the HOLD line goes low, the 8080 re-enters the halt state on the rising edge of the next  $\phi_1$  clock pulse.
- An interrupt (i.e., INT goes high while INTE is enabled) will cause the 8080 to exit the Halt state and enter state  $T_1$  on the rising edge of the next  $\phi_1$  clock pulse. NOTE: The interrupt enable (INTE) flag **must** be set when the halt state is entered; otherwise, the 8080 will only be able to exit via a RESET signal.

Figure 2-12 illustrates halt sequencing in flow chart form.

## START-UP OF THE 8080 CPU

When power is applied initially to the 8080, the processor begins operating immediately. The contents of its program counter, stack pointer, and the other working registers are naturally subject to random factors and cannot be specified. For this reason, it will be necessary to begin the power-up sequence with RESET.

An external RESET signal of three clock period duration (minimum) restores the processor's internal program counter to zero. Program execution thus begins with memory location zero, following a RESET. Systems which require the processor to wait for an explicit start-up signal will store a halt instruction (EI, HLT) in the first two locations. A manual or an automatic INTERRUPT will be used for starting. In other systems, the processor may begin executing its stored program immediately. Note, however, that the RESET has no effect on status flags, or on any of the processor's working registers (accumulator, registers, or stack pointer). The contents of these registers remain indeterminate, until initialized explicitly by the program.

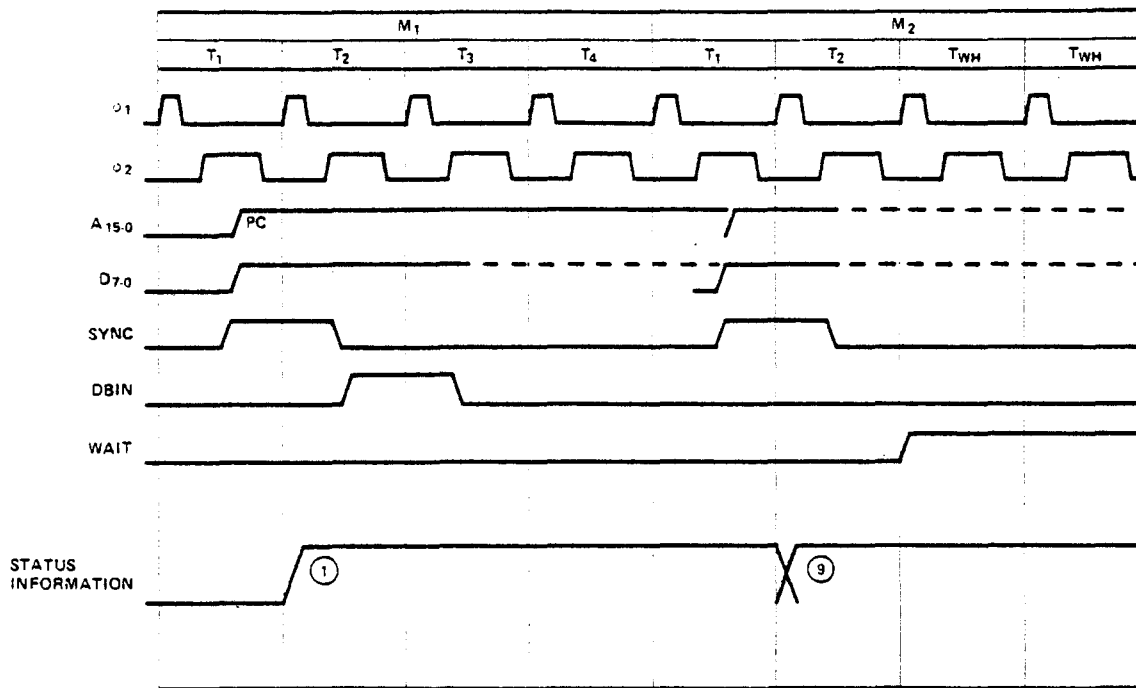

NOTE: (N) Refer to Status Word Chart on Page 2-6

Figure 2-11. HALT Timing

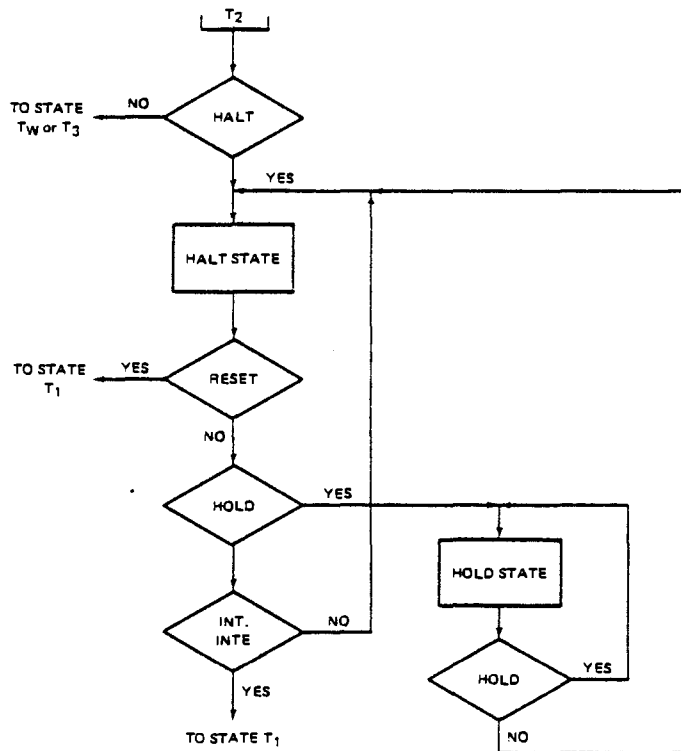

Figure 2-12. HALT Sequence Flow Chart.

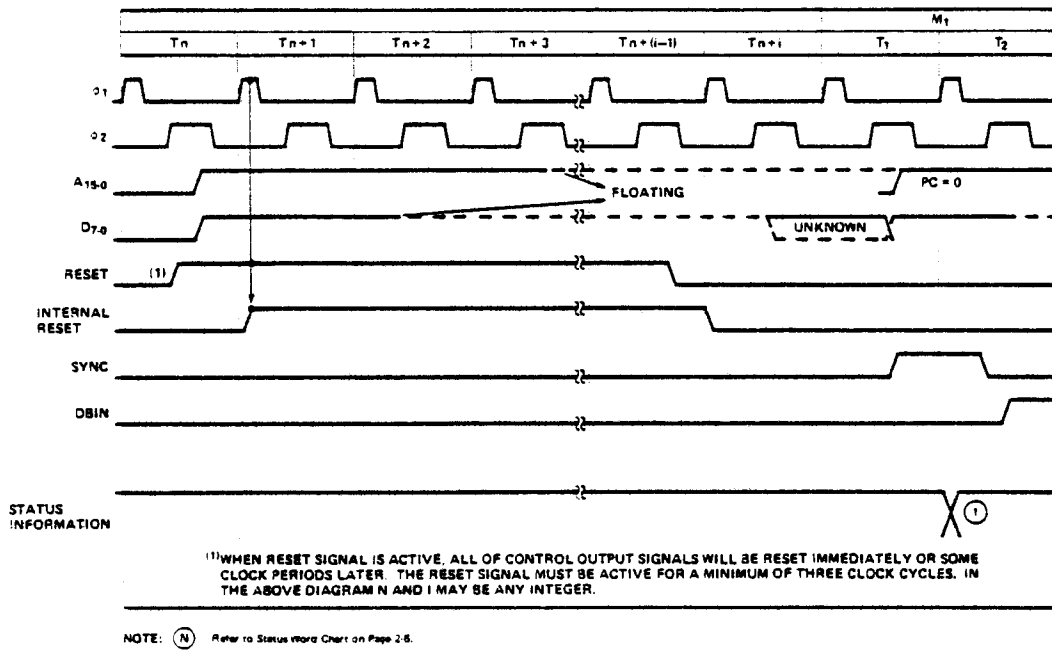

Figure 2-13. Reset.

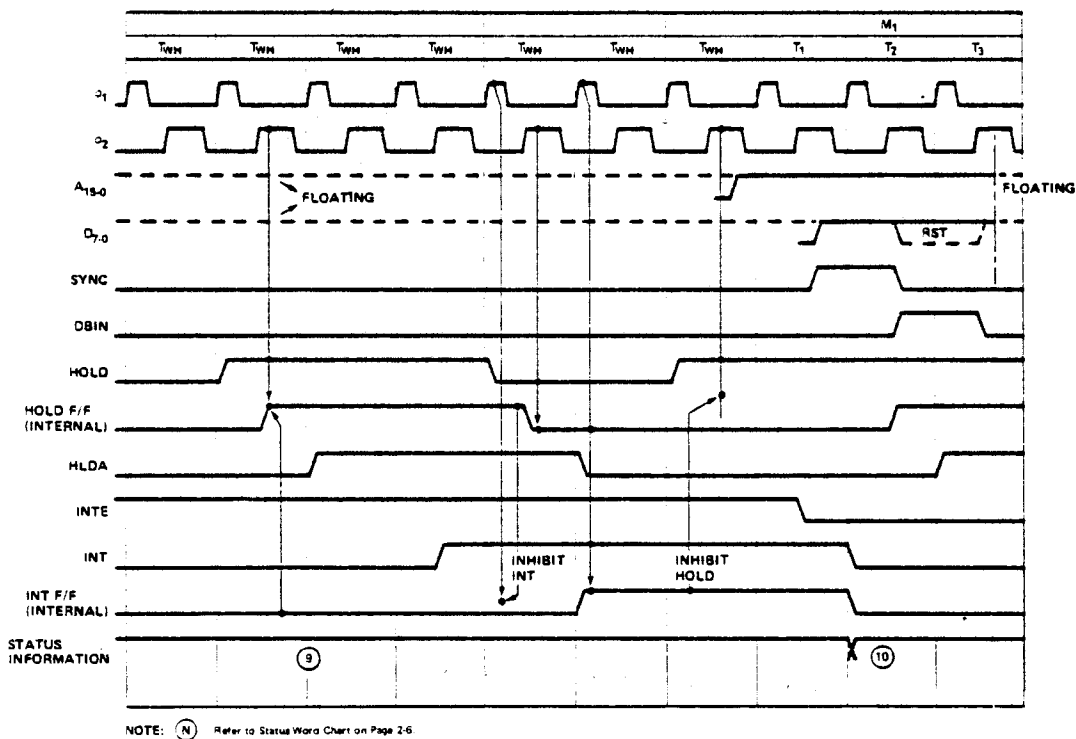

Figure 2-14. Relation between HOLD and INT in the HALT State.

| MNEMONIC     | OP CODE   |   | M1(1)         |             |             |                                |           | M2               |                                 |             |
|--------------|---|---|---------------|-------------|-------------|--------------------------------|-----------|------------------|---------------------------------|-------------|
|              | D <sub>7</sub> D <sub>6</sub> D <sub>5</sub> D <sub>4</sub> | D <sub>3</sub> D <sub>2</sub> D <sub>1</sub> D <sub>0</sub> | T1            | T2(2)       | T3          | T4                             | T5        | T1               | T2(2)                           | T3          |
| MOV r1,r2    | 0 1 0 0   | 0 1 1 1   | PC OUT STATUS | PC = PC + 1 | INST-TMP/IR | (SSS)-TMP                      | (TMP)-ODD |                  |                                 |             |
| MOV r, M     | 0 1 0 0   | 0 1 1 0   | ↑             | ↑           | ↑           | x(3)                           |           | HL OUT STATUS(6) | DATA → ODD                      |             |
| MOV M, r     | 0 1 1 1   | 0 1 1 1   |               |             |             | (SSS)-TMP                      |           | HL OUT STATUS(7) | (TMP) → DATA BUS                |             |
| SPLH         | 1 1 1 1   | 1 0 0 1   |               |             |             | (HL) → SP                      |           |                  |                                 |             |
| MVI r, data  | 0 0 0 0   | 0 1 1 0   |               |             |             | X                              |           | PC OUT STATUS(6) | 82 → ODD                        |             |
| MVI M, data  | 0 0 1 1   | 0 1 1 0   |               |             |             | X                              |           | ↑                | 82 → TMP                        |             |
| LXI rp, data | 0 0 0 0   | 0 0 0 1   |               |             |             | X                              |           |                  | PC = PC + 1                     | 82 → r1     |
| LDA addr     | 0 0 1 1   | 1 0 1 0   |               |             |             | X                              |           |                  | PC = PC + 1                     | 82 → Z      |
| STA addr     | 0 0 1 1   | 0 0 1 0   |               |             |             | X                              |           |                  | PC = PC + 1                     | 82 → Z      |
| LHLD addr    | 0 0 1 0   | 1 0 1 0   |               |             |             | X                              |           |                  | PC = PC + 1                     | 82 → Z      |
| SHLD addr    | 0 0 1 0   | 0 0 1 0   |               |             |             | X                              |           | PC OUT STATUS(6) | PC = PC + 1                     | 82 → Z      |
| LDAX rp(4)   | 0 0 0 0   | 1 0 1 0   |               |             |             | X                              |           | rp OUT STATUS(6) | DATA → A                        |             |
| STAX rp(4)   | 0 0 0 0   | 0 0 1 0   |               |             |             | X                              |           | rp OUT STATUS(7) | (A) → DATA BUS                  |             |
| XCHG         | 1 1 1 0   | 1 0 1 1   |               |             |             | (HL) ↔ (DE)                    |           |                  |                                 |             |
| ADD r        | 1 0 0 0   | 0 1 1 1   |               |             |             | (SSS)-TMP<br>(A) → ACT         |           | (9)              | (ACT)+(TMP) → A                 |             |
| ADD M        | 1 0 0 0   | 0 1 1 0   |               |             |             | (A) → ACT                      |           | HL OUT STATUS(6) | DATA → TMP                      |             |
| ADI data     | 1 1 0 0   | 0 1 1 0   |               |             |             | (A) → ACT                      |           | PC OUT STATUS(6) | PC = PC + 1                     | 82 → TMP    |
| ADC r        | 1 0 0 0   | 1 1 1 1   |               |             |             | (SSS)-TMP<br>(A) → ACT         |           | (9)              | (ACT)+(TMP)+CY → A              |             |
| ADC M        | 1 0 0 0   | 1 1 1 0   |               |             |             | (A) → ACT                      |           | HL OUT STATUS(6) | DATA → TMP                      |             |
| ACI data     | 1 1 0 0   | 1 1 1 0   |               |             |             | (A) → ACT                      |           | PC OUT STATUS(6) | PC = PC + 1                     | 82 → TMP    |
| SUB r        | 1 0 0 1   | 0 1 1 1   |               |             |             | (SSS)-TMP<br>(A) → ACT         |           | (9)              | (ACT)-(TMP) → A                 |             |
| SUB M        | 1 0 0 1   | 0 1 1 0   |               |             |             | (A) → ACT                      |           | HL OUT STATUS(6) | DATA → TMP                      |             |
| SUI data     | 1 1 0 1   | 0 1 1 0   |               |             |             | (A) → ACT                      |           | PC OUT STATUS(6) | PC = PC + 1                     | 82 → TMP    |
| SBB r        | 1 0 0 1   | 1 1 1 1   |               |             |             | (SSS)-TMP<br>(A) → ACT         |           | (9)              | (ACT)-(TMP)-CY → A              |             |
| SBB M        | 1 0 0 1   | 1 1 1 0   |               |             |             | (A) → ACT                      |           | HL OUT STATUS(6) | DATA → TMP                      |             |
| SBI data     | 1 1 0 1   | 1 1 1 0   |               |             |             | (A) → ACT                      |           | PC OUT STATUS(6) | PC = PC + 1                     | 82 → TMP    |
| INR r        | 0 0 0 0   | 0 1 0 0   |               |             |             | (ODD) → TMP<br>(TMP) + 1 → ALU | ALU-ODD   |                  |                                 |             |
| INR M        | 0 0 1 1   | 0 1 0 0   |               |             |             | X                              |           | HL OUT STATUS(6) | DATA → TMP<br>(TMP)+1 → ALU     |             |
| DCR r        | 0 0 0 0   | 0 1 0 1   |               |             |             | (ODD) → TMP<br>(TMP)+1 → ALU   | ALU-ODD   |                  |                                 |             |
| DCR M        | 0 0 1 1   | 0 1 0 1   |               |             |             | X                              |           | HL OUT STATUS(6) | DATA → TMP<br>(TMP)-1 → ALU     |             |
| INX rp       | 0 0 0 0   | 0 0 1 1   |               |             |             | (RP) + 1 → RP                  |           |                  |                                 |             |
| DCX rp       | 0 0 0 0   | 1 0 1 1   |               |             |             | (RP) - 1 → RP                  |           |                  |                                 |             |
| DAD rp(8)    | 0 0 0 0   | 1 0 0 1   |               |             |             | X                              |           | (ri) → ACT       | (L) → TMP,<br>(ACT)+(TMP) → ALU | ALU → L, CY |
| DAA          | 0 0 1 0   | 0 1 1 1   |               |             |             | DAA → A, FLAGS(10)             |           |                  |                                 |             |
| ANA r        | 1 0 1 0   | 0 1 1 1   |               |             |             | (SSS)-TMP<br>(A) → ACT         |           | (9)              | (ACT)+(TMP) → A                 |             |
| ANA M        | 1 0 1 0   | 0 1 1 0   | ↓             | ↓           | ↓           | (A) → ACT                      |           | PC OUT STATUS    | PC = PC + 1                     | INST-TMP/IR |
|              |   |   |               |             |             |                                |           | HL OUT STATUS(6) | DATA → TMP                      |             |



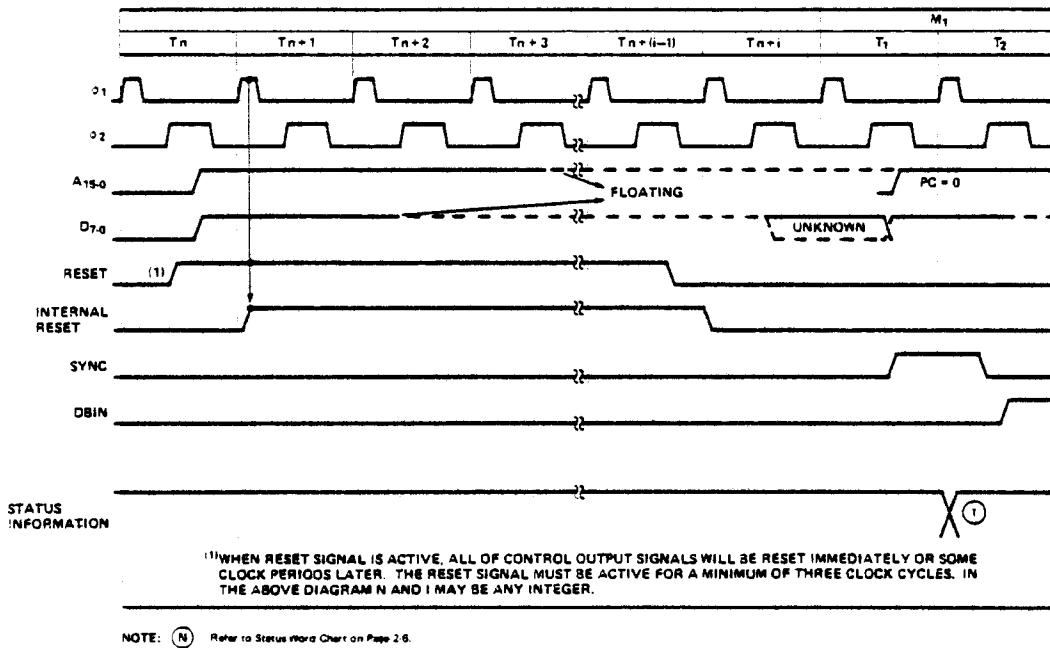

Figure 2-13. Reset.

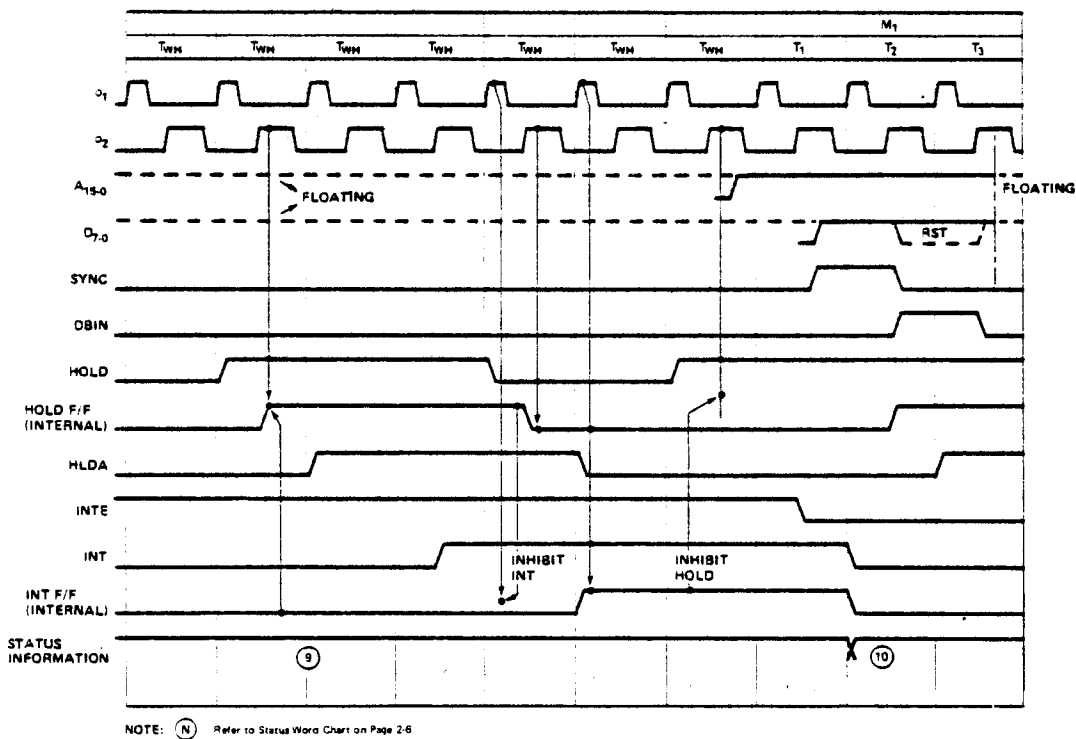

Figure 2-14. Relation between HOLD and INT in the HALT State.

| MNEMONIC     | OP CODE     |             | M1[1]         |             |                 |                             |             | M2               |  |    |
|--------------|-------------|-------------|---------------|-------------|-----------------|-----------------------------|-------------|------------------|--|----|
|              | D7 D6 D5 D4 | D3 D2 D1 D0 | T1            | T2[2]       | T3              | T4                          | T5          | T1               | T2[2]                                      | T3 |
| MOV r1, r2   | 0 1 0 0     | 0 1 1 1     | PC OUT STATUS | PC - PC + 1 | INST - TMP / IR | (SSS) - TMP                 | (TMP) - ODD |                  |  |    |
| MOV r, M     | 0 1 0 0     | 0 1 1 0     | ↑             | ↑           | ↑               | x[3]                        |             | HL OUT STATUS[6] | DATA → ODD                                 |    |
| MOV M, r     | 0 1 1 1     | 0 1 1 1     |               |             |                 | (SSS) - TMP                 |             | HL OUT STATUS[7] | (TMP) → DATA BUS                           |    |
| SPHL         | 1 1 1 1     | 1 0 0 1     |               |             |                 | (HL) → SP                   |             |                  |  |    |
| MVI r, data  | 0 0 0 0     | 0 1 1 0     |               |             |                 | X                           |             | PC OUT STATUS[6] | B2 → ODD                                   |    |
| MVI M, data  | 0 0 1 1     | 0 1 1 0     |               |             |                 | X                           |             | ↑                | B2 → TMP                                   |    |
| LXI rp, data | 0 0 0 0     | 0 0 0 1     |               |             |                 | X                           |             |                  | PC = PC + 1 B2 → r1                        |    |
| LDA addr     | 0 0 1 1     | 1 0 1 0     |               |             |                 | X                           |             |                  | PC = PC + 1 B2 → Z                         |    |
| STA addr     | 0 0 1 1     | 0 0 1 0     |               |             |                 | X                           |             |                  | PC = PC + 1 B2 → Z                         |    |
| LHLD addr    | 0 0 1 0     | 1 0 1 0     |               |             |                 | X                           |             |                  | PC = PC + 1 B2 → Z                         |    |
| SHLD addr    | 0 0 1 0     | 0 0 1 0     |               |             |                 | X                           |             | PC OUT STATUS[6] | PC = PC + 1 B2 → Z                         |    |
| LDAX rp[4]   | 0 0 0 0     | 1 0 1 0     |               |             |                 | X                           |             | rp OUT STATUS[6] | DATA → A                                   |    |
| STAX rp[4]   | 0 0 0 0     | 0 0 1 0     |               |             |                 | X                           |             | rp OUT STATUS[7] | (A) → DATA BUS                             |    |
| XCHG         | 1 1 1 0     | 1 0 1 1     |               |             |                 | (HL) ↔ (DE)                 |             |                  |  |    |
| ADD r        | 1 0 0 0     | 0 1 1 1     |               |             |                 | (SSS) - TMP (A) - ACT       |             | [9]              | (ACT) + (TMP) - A                          |    |
| ADD M        | 1 0 0 0     | 0 1 1 0     |               |             |                 | (A) - ACT                   |             | HL OUT STATUS[6] | DATA → TMP                                 |    |
| ADI data     | 1 1 0 0     | 0 1 1 0     |               |             |                 | (A) - ACT                   |             | PC OUT STATUS[6] | PC = PC + 1 B2 → TMP                       |    |
| ADC r        | 1 0 0 0     | 1 1 1 1     |               |             |                 | (SSS) - TMP (A) - ACT       |             | [9]              | (ACT) + (TMP) + CY - A                     |    |
| ADC M        | 1 0 0 0     | 1 1 1 0     |               |             |                 | (A) - ACT                   |             | HL OUT STATUS[6] | DATA → TMP                                 |    |
| ACI data     | 1 1 0 0     | 1 1 1 0     |               |             |                 | (A) - ACT                   |             | PC OUT STATUS[6] | PC = PC + 1 B2 → TMP                       |    |
| SUB r        | 1 0 0 1     | 0 1 1 1     |               |             |                 | (SSS) - TMP (A) - ACT       |             | [9]              | (ACT) - (TMP) - A                          |    |
| SUB M        | 1 0 0 1     | 0 1 1 0     |               |             |                 | (A) - ACT                   |             | HL OUT STATUS[6] | DATA → TMP                                 |    |
| SUI data     | 1 1 0 1     | 0 1 1 0     |               |             |                 | (A) - ACT                   |             | PC OUT STATUS[6] | PC = PC + 1 B2 → TMP                       |    |
| SBB r        | 1 0 0 1     | 1 1 1 1     |               |             |                 | (SSS) - TMP (A) - ACT       |             | [9]              | (ACT) - (TMP) - CY - A                     |    |
| SBB M        | 1 0 0 1     | 1 1 1 0     |               |             |                 | (A) - ACT                   |             | HL OUT STATUS[6] | DATA → TMP                                 |    |
| SBI data     | 1 1 0 1     | 1 1 1 0     |               |             |                 | (A) - ACT                   |             | PC OUT STATUS[6] | PC = PC + 1 B2 → TMP                       |    |
| INR r        | 0 0 0 0     | 0 1 0 0     |               |             |                 | (DDD) - TMP (TMP) + 1 - ALU | ALU - ODD   |                  |  |    |
| INR M        | 0 0 1 1     | 0 1 0 0     |               |             |                 | X                           |             | HL OUT STATUS[6] | DATA → TMP (TMP) + 1 → ALU                 |    |
| DCR r        | 0 0 0 0     | 0 1 0 1     |               |             |                 | (DDD) - TMP (TMP) + 1 - ALU | ALU - ODD   |                  |  |    |
| DCR M        | 0 0 1 1     | 0 1 0 1     |               |             |                 | X                           |             | HL OUT STATUS[6] | DATA → TMP (TMP) - 1 → ALU                 |    |
| INX rp       | 0 0 0 0     | 0 0 1 1     |               |             |                 | (RP) + 1 → RP               |             |                  |  |    |
| DCX rp       | 0 0 0 0     | 1 0 1 1     |               |             |                 | (RP) - 1 → RP               |             |                  |  |    |
| DAD rp[8]    | 0 0 0 0     | 1 0 0 1     |               |             |                 | X                           |             | (ri) - ACT       | (L) - TMP, (ACT) + (TMP) - ALU ALU → L, CY |    |
| DAA          | 0 0 1 0     | 0 1 1 1     |               |             |                 | DAA - A, FLAGS[10]          |             |                  |  |    |
| ANA r        | 1 0 1 0     | 0 1 1 1     |               |             |                 | (SSS) - TMP (A) - ACT       |             | [9]              | (ACT) + (TMP) - A                          |    |
| ANA M        | 1 0 1 0     | 0 1 1 0     | ↓             | ↓           | ↓               | (A) - ACT                   |             | HL OUT STATUS[6] | DATA → TMP                                 |    |

| M3               |                               |                  | M4               |                |    | M5               |                |    |    |    |
|------------------|-------------------------------|------------------|------------------|----------------|----|------------------|----------------|----|----|----|
| T1               | T2(2)                         | T3               | T1               | T2(2)          | T3 | T1               | T2(2)          | T3 | T4 | T5 |
|                  |                               |                  |                  |                |    |                  |                |    |    |    |
|                  |                               |                  |                  |                |    |                  |                |    |    |    |
|                  |                               |                  |                  |                |    |                  |                |    |    |    |
|                  |                               |                  |                  |                |    |                  |                |    |    |    |
|                  |                               |                  |                  |                |    |                  |                |    |    |    |
| HL OUT STATUS(7) |                               | (TMP) → DATA BUS |                  |                |    |                  |                |    |    |    |
| PC OUT STATUS(6) | PC = PC + 1                   | 83 → rh          |                  |                |    |                  |                |    |    |    |
|                  | PC = PC + 1                   | 83 → W           | WZ OUT STATUS(6) | DATA → A       |    |                  |                |    |    |    |
|                  | PC = PC + 1                   | 83 → W           | WZ OUT STATUS(7) | (A) → DATA BUS |    |                  |                |    |    |    |
|                  | PC = PC + 1                   | 83 → W           | WZ OUT STATUS(6) | DATA → L       |    | WZ OUT STATUS(6) | DATA → H       |    |    |    |
| PC OUT STATUS(6) | PC = PC + 1                   | 83 → W           | WZ OUT STATUS(7) | (L) → DATA BUS |    | WZ OUT STATUS(7) | (H) → DATA BUS |    |    |    |
|                  |                               |                  |                  |                |    |                  |                |    |    |    |
|                  |                               |                  |                  |                |    |                  |                |    |    |    |
|                  |                               |                  |                  |                |    |                  |                |    |    |    |
| [9]              | (ACT)+(TMP)-A                 |                  |                  |                |    |                  |                |    |    |    |
| [9]              | (ACT)+(TMP)-A                 |                  |                  |                |    |                  |                |    |    |    |
|                  |                               |                  |                  |                |    |                  |                |    |    |    |
| [9]              | (ACT)+(TMP)+CY-A              |                  |                  |                |    |                  |                |    |    |    |
| [9]              | (ACT)+(TMP)+CY-A              |                  |                  |                |    |                  |                |    |    |    |
|                  |                               |                  |                  |                |    |                  |                |    |    |    |
| [9]              | (ACT)-(TMP)-A                 |                  |                  |                |    |                  |                |    |    |    |
| [9]              | (ACT)-(TMP)-A                 | -                |                  |                |    |                  |                |    |    |    |
|                  |                               |                  |                  |                |    |                  |                |    |    |    |
| [9]              | (ACT)-(TMP)-CY-A              |                  |                  |                |    |                  |                |    |    |    |
| [9]              | (ACT)-(TMP)-CY-A              |                  |                  |                |    |                  |                |    |    |    |
|                  |                               |                  |                  |                |    |                  |                |    |    |    |
| HL OUT STATUS(7) |                               | ALU → DATA BUS   |                  |                |    |                  |                |    |    |    |
|                  |                               |                  |                  |                |    |                  |                |    |    |    |
| HL OUT STATUS(7) |                               | ALU → DATA BUS   |                  |                |    |                  |                |    |    |    |
|                  |                               |                  |                  |                |    |                  |                |    |    |    |
|                  |                               |                  |                  |                |    |                  |                |    |    |    |
| (rh)-ACT         | (H)-TMP<br>(ACT)+(TMP)+CY-ALU | ALU-H, CY        |                  |                |    |                  |                |    |    |    |
|                  |                               |                  |                  |                |    |                  |                |    |    |    |
|                  |                               |                  |                  |                |    |                  |                |    |    |    |
| [9]              | (ACT)+(TMP)-A                 |                  |                  |                |    |                  |                |    |    |    |

| MNEMONIC        | OP CODE   |   | M1(11)        |             |             |                                      |                     | M2                |                    |          |
|-----------------|---|---|---------------|-------------|-------------|--------------------------------------|---------------------|-------------------|--------------------|----------|
|                 | D <sub>7</sub> D <sub>6</sub> D <sub>5</sub> D <sub>4</sub> | D <sub>3</sub> D <sub>2</sub> D <sub>1</sub> D <sub>0</sub> | T1            | T2(2)       | T3          | T4                                   | T5                  | T1                | T2(2)              | T3       |
| ANI data        | 1 1 1 0   | 0 1 1 0   | PC OUT STATUS | PC = PC + 1 | INST-TMP/IR | (A)-ACT                              |                     | PC OUT STATUS(6)  | PC = PC + 1 82     | TMP      |
| XRA r           | 1 0 1 0   | 1 S S S   |               |             |             | (A)-ACT (SSS)-TMP                    |                     | (9)               | (ACT)+(TMP)-A      |          |
| XRA M           | 1 0 1 0   | 1 1 1 0   |               |             |             | (A)-ACT                              |                     | HL OUT STATUS(6)  | DATA               | TMP      |
| XRI data        | 1 1 1 0   | 1 1 1 0   |               |             |             | (A)-ACT                              |                     | PC OUT STATUS(6)  | PC = PC + 1 82     | TMP      |
| ORA r           | 1 0 1 1   | 0 S S S   |               |             |             | (A)-ACT (SSS)-TMP                    |                     | (9)               | (ACT)+(TMP)-A      |          |
| ORA M           | 1 0 1 1   | 0 1 1 0   |               |             |             | (A)-ACT                              |                     | HL OUT STATUS(6)  | DATA               | TMP      |
| ORI data        | 1 1 1 1   | 0 1 1 0   |               |             |             | (A)-ACT                              |                     | PC OUT STATUS(6)  | PC = PC + 1 82     | TMP      |
| CMP r           | 1 0 1 1   | 1 S S S   |               |             |             | (A)-ACT (SSS)-TMP                    |                     | (9)               | (ACT)-(TMP), FLAGS |          |
| CMP M           | 1 0 1 1   | 1 1 1 0   |               |             |             | (A)-ACT                              |                     | HL OUT STATUS(6)  | DATA               | TMP      |
| CPI data        | 1 1 1 1   | 1 1 1 0   |               |             |             | (A)-ACT                              |                     | PC OUT STATUS(6)  | PC = PC + 1 82     | TMP      |
| RLC             | 0 0 0 0   | 0 1 1 1   |               |             |             | (A)-ALU ROTATE                       |                     | (9)               | ALU-A, CY          |          |
| RRC             | 0 0 0 0   | 1 1 1 1   |               |             |             | (A)-ALU ROTATE                       |                     | (9)               | ALU-A, CY          |          |
| RAL             | 0 0 0 1   | 0 1 1 1   |               |             |             | (A), CY-ALU ROTATE                   |                     | (9)               | ALU-A, CY          |          |
| RAR             | 0 0 0 1   | 1 1 1 1   |               |             |             | (A), CY-ALU ROTATE                   |                     | (9)               | ALU-A, CY          |          |
| CMA             | 0 0 1 0   | 1 1 1 1   |               |             |             | (A)-A                                |                     |                   |                    |          |
| CMC             | 0 0 1 1   | 1 1 1 1   |               |             |             | CY-CY                                |                     |                   |                    |          |
| STC             | 0 0 1 1   | 0 1 1 1   |               |             |             | 1-CY                                 |                     |                   |                    |          |
| JMP addr        | 1 1 0 0   | 0 0 1 1   |               |             |             |                                      | X                   | PC OUT STATUS(6)  | PC = PC + 1 82     | Z        |
| J cond addr(17) | 1 1 C C   | C 0 1 0   |               |             |             | JUDGE CONDITION                      |                     | PC OUT STATUS(6)  | PC = PC + 1 82     | Z        |
| CALL addr       | 1 1 0 0   | 1 1 0 1   |               |             |             | SP = SP - 1                          |                     | PC OUT STATUS(6)  | PC = PC + 1 82     | Z        |
| C cond addr(17) | 1 1 C C   | C 1 0 0   |               |             |             | JUDGE CONDITION IF TRUE, SP = SP - 1 |                     | PC OUT STATUS(6)  | PC = PC + 1 82     | Z        |
| RET             | 1 1 0 0   | 1 0 0 1   |               |             |             |                                      | X                   | SP OUT STATUS(15) | SP = SP + 1 DATA   | Z        |
| R cond addr(17) | 1 1 C C   | C 0 0 0   |               |             |             | INST-TMP/IR                          | JUDGE CONDITION(14) | SP OUT STATUS(15) | SP = SP + 1 DATA   | Z        |
| RST n           | 1 1 N N   | N 1 1 1   |               |             |             | 0-W INST-TMP/IR                      | SP = SP - 1         | SP OUT STATUS(16) | SP = SP - 1 (PCH)  | DATA BUS |
| PCHL            | 1 1 1 0   | 1 0 0 1   |               |             |             | INST-TMP/IR                          | (HL) → PC           |                   |                    |          |
| PUSH rp         | 1 1 R P   | 0 1 0 1   |               |             |             |                                      | SP = SP - 1         | SP OUT STATUS(16) | SP = SP - 1 (rh)   | DATA BUS |
| PUSH PSW        | 1 1 1 1   | 0 1 0 1   |               |             |             |                                      | SP = SP - 1         | SP OUT STATUS(16) | SP = SP - 1 (A)    | DATA BUS |
| POP rp          | 1 1 R P   | 0 0 0 1   |               |             |             |                                      | X                   | SP OUT STATUS(15) | SP = SP + 1 DATA   | r1       |
| POP PSW         | 1 1 1 1   | 0 0 0 1   |               |             |             |                                      | X                   | SP OUT STATUS(15) | SP = SP + 1 DATA   | FLAGS    |
| XTHL            | 1 1 1 0   | 0 0 1 1   |               |             |             |                                      | X                   | SP OUT STATUS(15) | SP = SP + 1 DATA   | Z        |
| IN port         | 1 1 0 1   | 1 0 1 1   |               |             |             |                                      | X                   | PC OUT STATUS(6)  | PC = PC + 1 82     | Z, W     |
| OUT port        | 1 1 0 1   | 0 0 1 1   |               |             |             |                                      | X                   | PC OUT STATUS(6)  | PC = PC + 1 82     | Z, W     |
| EI              | 1 1 1 1   | 1 0 1 1   |               |             |             | SET INTE F/F                         |                     |                   |                    |          |
| DI              | 1 1 1 1   | 0 0 1 1   |               |             |             | RESET INTE F/F                       |                     |                   |                    |          |
| HLT             | 0 1 1 1   | 0 1 1 0   |               |             |             |                                      | X                   | PC OUT STATUS     | HALT MODE(20)      |          |
| NOP             | 0 0 0 0   | 0 0 0 0   | PC OUT STATUS | PC = PC + 1 | INST-TMP/IR |                                      | X                   |                   |                    |          |



**NOTES:**

- 1. The first memory cycle (M1) is always an instruction fetch; the first (or only) byte, containing the op code, is fetched during this cycle.
- 2. If the READY input from memory is not high during T2 of each memory cycle, the processor will enter a wait state (TW) until READY is sampled as high.
- 3. States T4 and T5 are present, as required, for operations which are completely internal to the CPU. The contents of the internal bus during T4 and T5 are available at the data bus; this is designed for testing purposes only. An "X" denotes that the state is present, but is only used for such internal operations as instruction decoding.
- 4. Only register pairs rp = B (registers B and C) or rp = D (registers D and E) may be specified.
- 5. These states are skipped.
- 6. Memory read sub-cycles; an instruction or data word will be read.
- 7. Memory write sub-cycle.
- 8. The READY signal is not required during the second and third sub-cycles (M2 and M3). The HOLD signal is accepted during M2 and M3. The SYNC signal is not generated during M2 and M3. During the execution of DAD, M2 and M3 are required for an internal register-pair add; memory is not referenced.
- 9. The results of these arithmetic, logical or rotate instructions are not moved into the accumulator (A) until state T2 of the next instruction cycle. That is, A is loaded while the next instruction is being fetched; this overlapping of operations allows for faster processing.
- 10. If the value of the least significant 4-bits of the accumulator is greater than 9 or if the auxiliary carry bit is set, 6 is added to the accumulator. If the value of the most significant 4-bits of the accumulator is now greater than 9, or if the carry bit is set, 6 is added to the most significant 4-bits of the accumulator.
- 11. This represents the first sub-cycle (the instruction fetch) of the next instruction cycle.

- 12. If the condition was met, the contents of the register pair WZ are output on the address lines (A<sub>0-15</sub>) instead of the contents of the program counter (PC).
- 13. If the condition was not met, sub-cycles M4 and M5 are skipped; the processor instead proceeds immediately to the instruction fetch (M1) of the next instruction cycle.
- 14. If the condition was not met, sub-cycles M2 and M3 are skipped; the processor instead proceeds immediately to the instruction fetch (M1) of the next instruction cycle.
- 15. Stack read sub-cycle.
- 16. Stack write sub-cycle.
- 17. CONDITION CCC
  - NZ — not zero (Z = 0) 000
  - Z — zero (Z = 1) 001
  - NC — no carry (CY = 0) 010
  - C — carry (CY = 1) 011
  - PO — parity odd (P = 0) 100
  - PE — parity even (P = 1) 101
  - P — plus (S = 0) 110
  - M — minus (S = 1) 111
- 18. I/O sub-cycle: the I/O port's 8-bit select code is duplicated on address lines 0-7 (A<sub>0-7</sub>) and 8-15 (A<sub>8-15</sub>).
- 19. Output sub-cycle.
- 20. The processor will remain idle in the halt state until an interrupt, a reset or a hold is accepted. When a hold request is accepted, the CPU enters the hold mode; after the hold mode is terminated, the processor returns to the halt state. After a reset is accepted, the processor begins execution at memory location zero. After an interrupt is accepted, the processor executes the instruction forced onto the data bus (usually a restart instruction).

| SSS or DDD | Value | rp | Value |
|------------|-------|----|-------|
| A          | 111   | B  | 00    |
| B          | 000   | D  | 01    |
| C          | 001   | H  | 10    |
| D          | 010   | SP | 11    |
| E          | 011   |    |       |
| H          | 100   |    |       |
| L          | 101   |    |       |

# CHAPTER 3 INTERFACING THE 8080

This chapter will illustrate, in detail, how to interface the 8080 CPU with Memory and I/O. It will also show the benefits and tradeoffs encountered when using a variety of system architectures to achieve higher throughput, decreased component count or minimization of memory size.

8080 Microcomputer system design lends itself to a simple, modular approach. Such an approach will yield the designer a reliable, high performance system that contains a minimum component count and is easy to manufacture and maintain.

The overall system can be thought of as a simple block diagram. The three (3) blocks in the diagram represent the functions common to any computer system.

**CPU Module\*** Contains the Central Processing Unit, system timing and interface circuitry to Memory and I/O devices.

**Memory** Contains Read Only Memory (ROM) and Read/Write Memory (RAM) for program and data storage.

**I/O** Contains circuitry that allows the computer system to communicate with devices or structures existing outside of the CPU or Memory array.

for example: Keyboards, Floppy Disks, Paper Tape, etc.

There are three busses that interconnect these blocks:

**Data Bus†** A bi-directional path on which data can flow between the CPU and Memory or I/O.

**Address Bus** A uni-directional group of lines that identify a particular Memory location or I/O device.

\*"Module" refers to a functional block, it does not reference a printed circuit board manufactured by INTEL.

†"Bus" refers to a set of signals grouped together because of the similarity of their functions.

**Control Bus** A uni-directional set of signals that indicate the type of activity in current process.

- Type of activities:
1. Memory Read
  2. Memory Write
  3. I/O Read
  4. I/O Write
  5. Interrupt Acknowledge

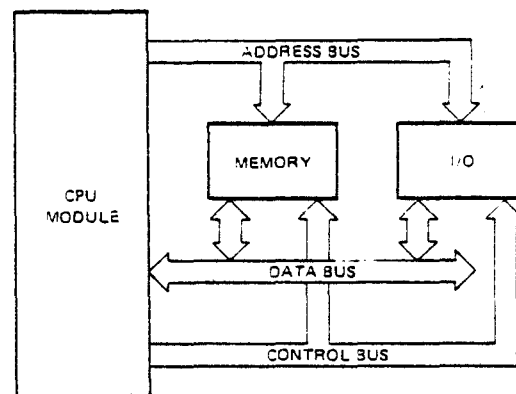

Figure 3-1. Typical Computer System Block Diagram

### Basic System Operation

1. The CPU Module issues an activity command on the Control Bus.
2. The CPU Module issues a binary code on the Address Bus to identify which particular Memory location or I/O device will be involved in the current process activity.
3. The CPU Module receives or transmits data with the selected Memory location or I/O device.
4. The CPU Module returns to ① and issues the next activity command.

It is easy to see at this point that the CPU module is the central element in any computer system.

The following pages will cover the detailed design of the CPU Module with the 8080. The three Busses (Data, Address and Control) will be developed and the interconnection to Memory and I/O will be shown.

Design philosophies and system architectures presented in this manual are consistent with product development programs underway at INTEL for the MCS-80. Thus, the designer who uses this manual as a guide for his total system engineering is assured that all new developments in components and software for MCS-80 from INTEL will be compatible with his design approach.

### CPU Module Design

The CPU Module contains three major areas:

1. The 8080 Central Processing Unit
2. A Clock Generator and High Level Driver
3. A bi-directional Data Bus Driver and System Control Logic

The following will discuss the design of the three major areas contained in the CPU Module. This design is presented as an alternative to the Intel® 8224 Clock Generator and Intel 8228 System Controller. By studying the alternative approach, the designer can more clearly see the considerations involved in the specification and engineering of the 8224 and 8228. Standard TTL components and Intel general purpose peripheral devices are used to implement

the design and to achieve operational characteristics that are as close as possible to those of the 8224 and 8228. Many auxiliary timing functions and features of the 8224 and 8228 are too complex to practically implement in standard components, so only the basic functions of the 8224 and 8228 are generated. Since significant benefits in system timing and component count reduction can be realized by using the 8224 and 8228, this is the preferred method of implementation.

#### 1. 8080 CPU

The operation of the 8080 CPU was covered in previous chapters of this manual, so little reference will be made to it in the design of the Module.

#### 2. Clock Generator and High Level Driver

The 8080 is a dynamic device, meaning that its internal storage elements and logic circuitry require a timing reference (Clock), supplied by external circuitry, to refresh and provide timing control signals.

The 8080 requires two (2) such Clocks. Their waveforms must be non-overlapping, and comply with the timing and levels specified in the 8080 A.C. and D.C. Characteristics, page 5-15.

#### Clock Generator Design

The Clock Generator consists of a crystal controlled,

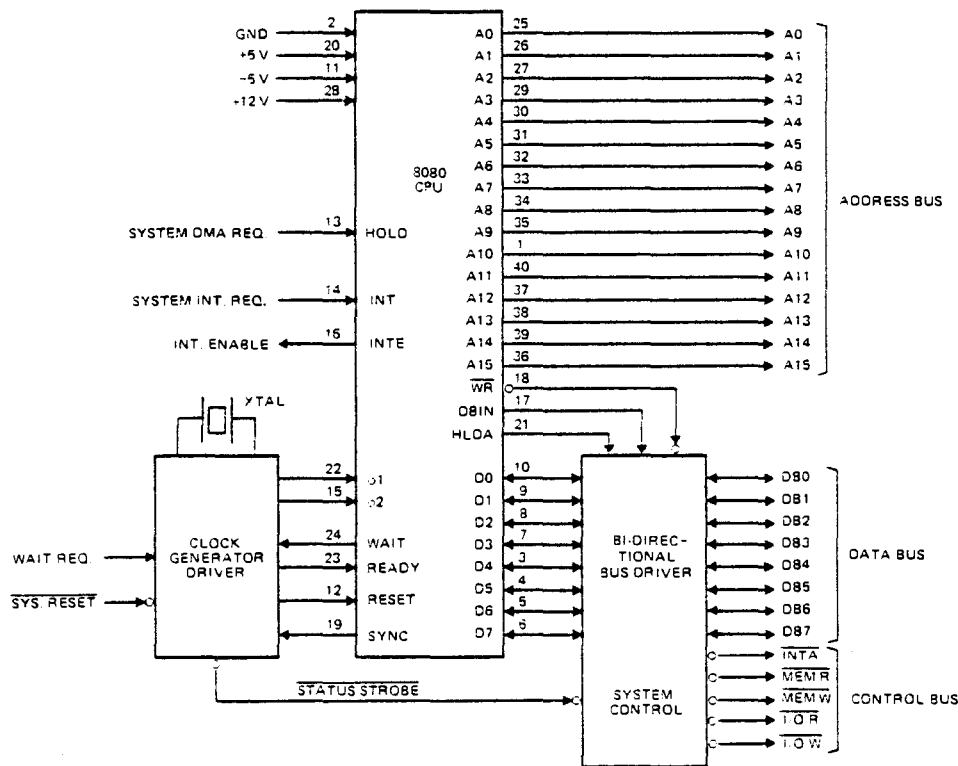

Figure 3-2. 8080 CPU Interface



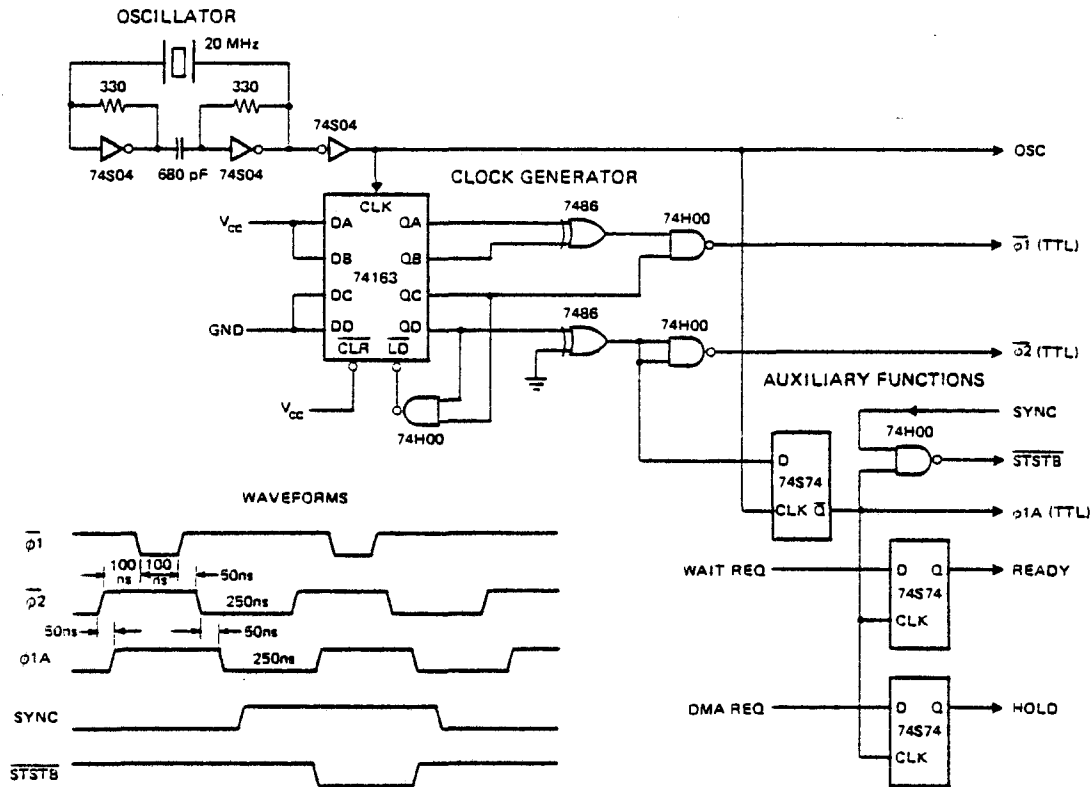

Figure 3-3. 8080 Clock Generator

20 MHz oscillator, a four bit counter, and gating circuits.

The oscillator provides a 20 MHz signal to the input of a four (4) bit, presetable, synchronous, binary counter. By presetting the counter as shown in figure 3-3 and clocking it with the 20 MHz signal, a simple decoding of the counters outputs using standard TTL gates, provides proper timing for the two (2) 8080 clock inputs.

Note that the timing must actually be measured at the output of the High Level Driver to take into account the added delays and waveform distortions within such a device.

#### High Level Driver Design

The voltage level of the clocks for the 8080 is not TTL compatible like the other signals that input to the 8080. The voltage swing is from .6 volts ( $V_{ILC}$ ) to 11 volts ( $V_{IHC}$ ) with risetimes and falltimes under 50 ns. The Capacitive Drive is 20 pf (max.). Thus, a High Level Driver is required to interface the outputs of the Clock Generator (TTL) to the 8080.

The two (2) outputs of the Clock Generator are capacitively coupled to a dual High Level clock driver. The driver must be capable of complying with the 8080 clock input specifications, page 5-15. A driver of this type usually has little problem supplying the

positive transition when biased from the 8080  $V_{DD}$  supply (12V) but to achieve the low voltage specification ( $V_{ILC}$ ) .8 volts Max. the driver is biased to the 8080  $V_{BB}$  supply (-5V). This allows the driver to swing from GND to  $V_{DD}$  with the aid of a simple resistor divider.

A low resistance series network is added between the driver and the 8080 to eliminate any overshoot of the pulsed waveforms. Now a circuit is apparent that can easily comply with the 8080 specifications. In fact rise and falltimes of this design are typically less than 10 ns.

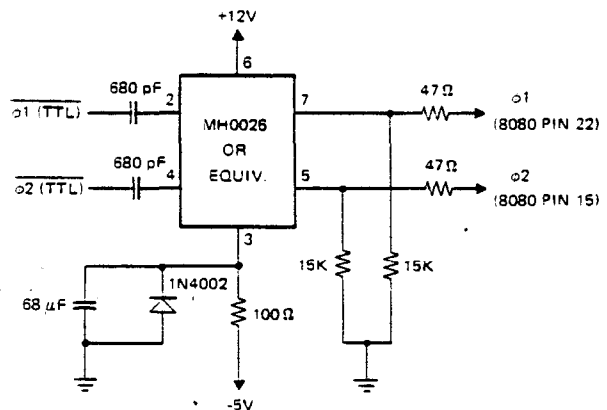

Figure 3-4. High Level Driver

### Auxiliary Timing Signals and Functions

The Clock Generator can also be used to provide other signals that the designer can use to simplify large system timing or the interface to dynamic memories.

Functions such as power-on reset, synchronization of external requests (HOLD, READY, etc.) and single step, could easily be added to the Clock Generator to further enhance its capabilities.

For instance, the 20 MHz signal from the oscillator can be buffered so that it could provide the basis for communication baud rate generation.

The Clock Generator diagram also shows how to generate an advanced timing signal ( $\phi 1A$ ) that is handy to use in clocking "D" type flipflops to synchronize external requests. It can also be used to generate a strobe ( $\overline{STSTB}$ ) that is the latching signal for the status information which is available on the Data Bus at the beginning of each machine cycle. A simple gating of the SYNC signal from the 8080 and the advanced ( $\phi 1A$ ) will do the job. See Figure 3-3.

### 3. Bi-Directional Bus Driver and System Control Logic

The system Memory and I/O devices communicate with the CPU over the bi-directional Data Bus. The system Control Bus is used to gate data on and off the Data Bus within the proper timing sequences as dictated by the operation of the 8080 CPU. The data lines of the 8080 CPU, Memory and I/O devices are 3-state in nature, that is, their output drivers have the ability to be forced into a high-impedance mode and are, effectively, removed from the circuit. This 3-state bus technique allows the designer to construct a system around a single, eight (8) bit parallel, bi-directional Data Bus and simply gate the information on or off this bus by selecting or deselecting (3-stating) Memory and I/O devices with signals from the Control Bus.

#### Bi-Directional Data Bus Driver Design

The 8080 Data Bus (D7-D0) has two (2) major areas of concern for the designer:

1. Input Voltage level ( $V_{IH}$ ) 3.3 volts minimum.
2. Output Drive Capability ( $I_{OL}$ ) 1.7 mA maximum.

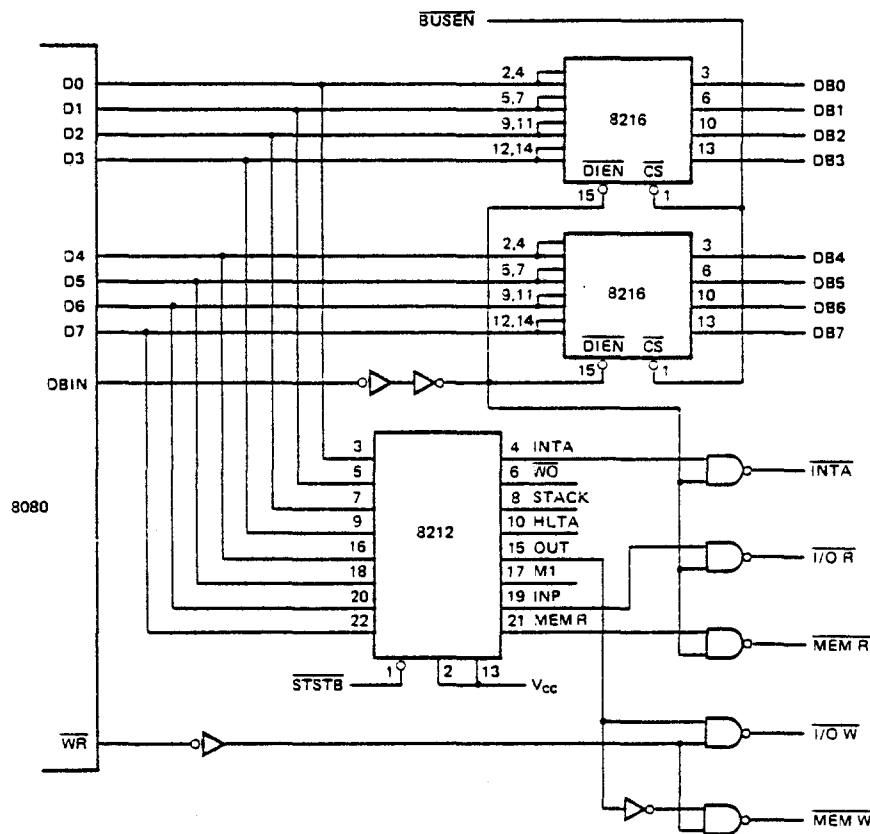

Figure 3-5. 8080 System Control

The input level specification implies that any semiconductor memory or I/O device connected to the 8080 Data Bus must be able to provide a minimum of 3.3 volts in its high state. Most semiconductor memories and standard TTL I/O devices have an output capability of between 2.0 and 2.8 volts, obviously a direct connection onto the 8080 Data Bus would require pullup resistors, whose value should not affect the bus speed or stress the drive capability of the memory or I/O components.

The 8080A output drive capability ( $I_{OL}$ ) 1.9mA max. is sufficient for small systems where Memory size and I/O requirements are minimal and the entire system is contained on a single printed circuit board. Most systems however, take advantage of the high-performance computing power of the 8080 CPU and thus a more typical system would require some form of buffering on the 8080 Data Bus to support a larger array of Memory and I/O devices which are likely to be on separate boards.

A device specifically designed to do this buffering function is the INTEL<sup>®</sup> 8216, a (4) four bit bi-directional bus driver whose input voltage level is compatible with standard TTL devices and semiconductor memory components, and has output drive capability of 50 mA. At the 8080 side, the 8216 has a "high" output of 3.65 volts that not only meets the 8080 input spec but provides the designer with a worse case 350 mV noise margin.

A pair of 8216's are connected directly to the 8080 Data Bus (D7-D0) as shown in figure 3-5. Note that the DBIN signal from the 8080 is connected to the direction control input ( $\overline{DIEN}$ ) so the correct flow of data on the bus is maintained. The chip select ( $\overline{CS}$ ) of the 8216 is connected to BUS ENABLE ( $\overline{BUSEN}$ ) to allow for DMA activities by deselecting the Data Bus Buffer and forcing the outputs of the 8216's into their high impedance (3-state) mode. This allows other devices to gain access to the data bus (DMA).

### System Control Logic Design

The Control Bus maintains discipline of the bi-directional Data Bus, that is, it determines what type of device will have access to the bus (Memory or I/O) and generates signals to assure that these devices transfer Data with the 8080 CPU within the proper timing "windows" as dictated by the CPU operational characteristics.

As described previously, the 8080 issues Status information at the beginning of each Machine Cycle on its Data Bus to indicate what operation will take place during that cycle. A simple (8) bit latch, like an INTEL<sup>®</sup> 8212, connected directly to the 8080 Data Bus (D7-D0) as shown in figure 3-5 will store the

Status information. The signal that loads the data into the Status Latch comes from the Clock Generator, it is Status Strobe ( $\overline{STSTB}$ ) and occurs at the start of each Machine Cycle.

Note that the Status Latch is connected onto the 8080 Data Bus (D7-D0) before the Bus Buffer. This is to maintain the integrity of the Data Bus and simplify Control Bus timing in DMA dependent environments.

As shown in the diagram, a simple gating of the outputs of the Status Latch with the DBIN and  $\overline{WR}$  signals from the 8080 generate the (4) four Control signals that make up the basic Control Bus.

- These four signals:
1. Memory Read ( $\overline{MEM R}$ )
  2. Memory Write ( $\overline{MEM W}$ )
  3. I/O Read ( $\overline{I/O R}$ )
  4. I/O Write ( $\overline{I/O W}$ )

connect directly to the MCS-80 component "family" of ROMs, RAMs and I/O devices.

A fifth signal, Interrupt Acknowledge ( $\overline{INTA}$ ) is added to the Control Bus by gating data off the Status Latch with the DBIN signal from the 8080 CPU. This signal is used to enable the Interrupt Instruction Port which holds the RST instruction onto the Data Bus.

Other signals that are part of the Control Bus such as  $\overline{WO}$ , Stack and M1 are present to aid in the testing of the System and also to simplify interfacing the CPU to dynamic memories or very large systems that require several levels of bus buffering.

### Address Buffer Design

The Address Bus (A15-A0) of the 8080, like the Data Bus, is sufficient to support a small system that has a moderate size Memory and I/O structure, confined to a single card. To expand the size of the system that the Address Bus can support a simple buffer can be added, as shown in figure 3-6. The INTEL<sup>®</sup> 8212 or 8216 is an excellent device for this function. They provide low input loading (.25 mA), high output drive and insert a minimal delay in the System Timing.

Note that BUS ENABLE ( $\overline{BUSEN}$ ) is connected to the buffers so that they are forced into their high-impedance (3-state) mode during DMA activities so that other devices can gain access to the Address Bus.

## INTERFACING THE 8080 CPU TO MEMORY AND I/O DEVICES

The 8080 interfaces with standard semiconductor Memory components and I/O devices. In the previous text the proper control signals and buffering were developed which will produce a simple bus system similar to the basic system example shown at the beginning of this chapter.

In Figure 3-6 a simple, but exact 8080 typical system is shown that can be used as a guide for any 8080 system, regardless of size or complexity. It is a "three bus" architecture, using the signals developed in the CPU module.

Note that Memory and I/O devices interface in the same manner and that their isolation is only a function of the definition of the Read-Write signals on the Control Bus. This allows the 8080 system to be configured so that Memory and I/O are treated as a single array (memory mapped I/O) for small systems that require high thrupt and have less than 32K memory size. This approach will be brought out later in the chapter.

### ROM INTERFACE

A ROM is a device that stores data in the form of Program or other information such as "look-up tables" and is only read from, thus the term Read Only Memory. This type of memory is generally non-volatile, meaning that when the power is removed the information is retained.

This feature eliminates the need for extra equipment like tape readers and disks to load programs initially, an important aspect in small system design.

Interfacing standard ROMs, such as the devices shown in the diagram is simple and direct. The output Data lines are connected to the bi-directional Data Bus, the Address inputs tie to the Address bus with possible decoding of the most significant bits as "chip selects" and the  $\overline{\text{MEMR}}$  signal from the Control Bus connected to a "chip select" or data buffer. Basically, the CPU issues an address during the first portion of an instruction or data fetch (T1 & T2). This value on the Address Bus selects a specific location within the ROM, then depending on the ROM's delay (access time) the data stored at the addressed location is present at the Data output lines. At this time (T3) the CPU Data Bus is in the "input Mode" and the control logic issues a Memory Read command ( $\overline{\text{MEMR}}$ ) that gates the addressed data on to the Data Bus.

### RAM INTERFACE

A RAM is a device that stores data. This data can be program, active "look-up tables," temporary values or external stacks. The difference between RAM and ROM is that data can be written into such devices and are in essence, Read/Write storage elements. RAMs do not hold their data when power is removed so in the case where Program or "look-up tables" data is stored a method to load

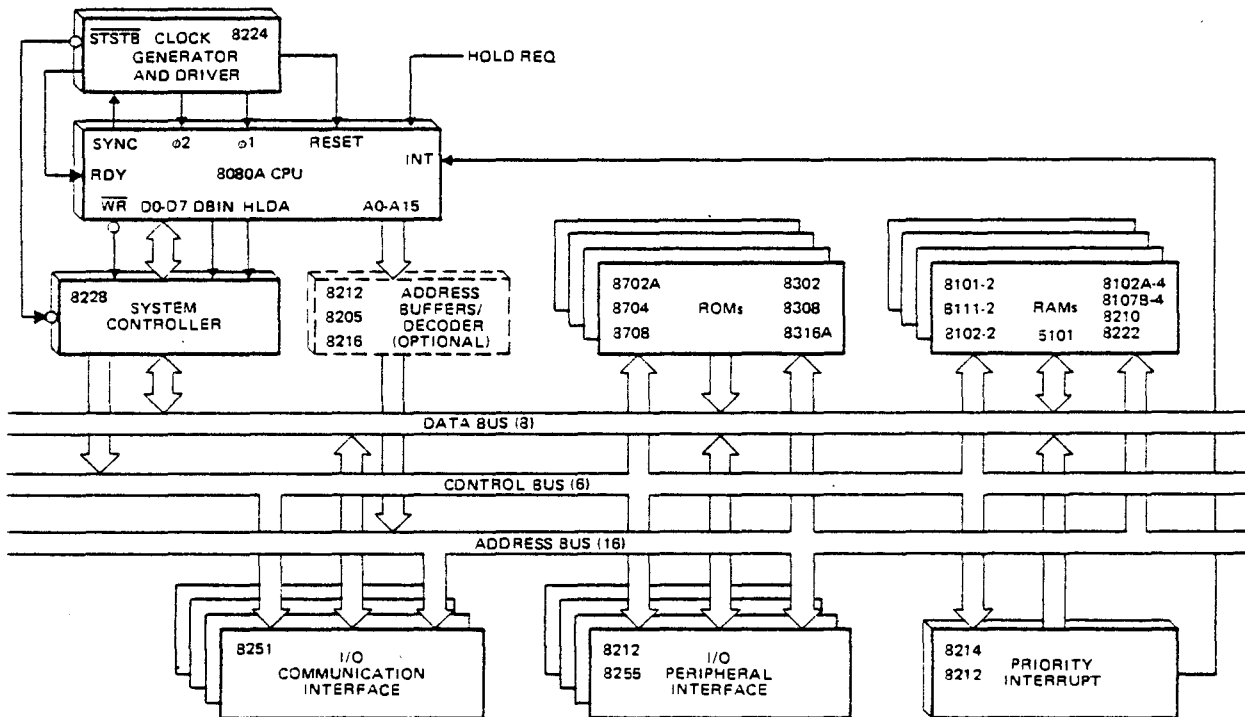

Figure 3-6. Microcomputer System

RAM memory must be provided, such as: Floppy Disk, Paper Tape, etc.

The CPU treats RAM in exactly the same manner as ROM for addressing data to be read. Writing data is very similar; the RAM is issued an address during the first portion of the Memory Write cycle (T1 & T2) in T3 when the data that is to be written is output by the CPU and is stable on the bus an MEMW command is generated. The MEMW signal is connected to the R/W input of the RAM and strobes the data into the addressed location.

In Figure 3-7 a typical Memory system is illustrated to show how standard semiconductor components interface to the 8080 bus. The memory array shown has 8K bytes (8 bits/byte) of ROM storage, using four Intel® 8216As and 512 bytes of RAM storage, using Intel 8111 static RAMs. The basic interface to the bus structure detailed here is common to almost any size memory. The only addition that might have to be made for larger systems is more buffers (8216/8212) and decoders (8205) for generating "chip selects."

The memories chosen for this example have an access time of 850 nS (max) to illustrate that slower, economical devices can be easily interfaced to the 8080 with little effect on performance. When the 8080 is operated from a clock generator with a tCY of 500 nS the required memory access time is Approx. 450-550 nS. See detailed timing specification Pg. 5-16. Using memory devices of this speed such as Intel® 8308, 8102A, 8107A, etc. the READY input to the 8080 CPU can remain "high" because no "wait" states are required. Note that the bus interface to memory shown in Figure 3-7 remains the same. However, if slower memories are to be used, such as the devices illustrated (8316A, 8111) that have access times slower than the minimum requirement a simple logic control of the READY input to the 8080 CPU will insert an extra "wait state" that is equal to one or more clock periods as an access time "adjustment" delay to compensate. The effect of the extra "wait" state is naturally a slower execution time for the instruction. A single "wait" changes the basic instruction cycle to 2.5 microSeconds.

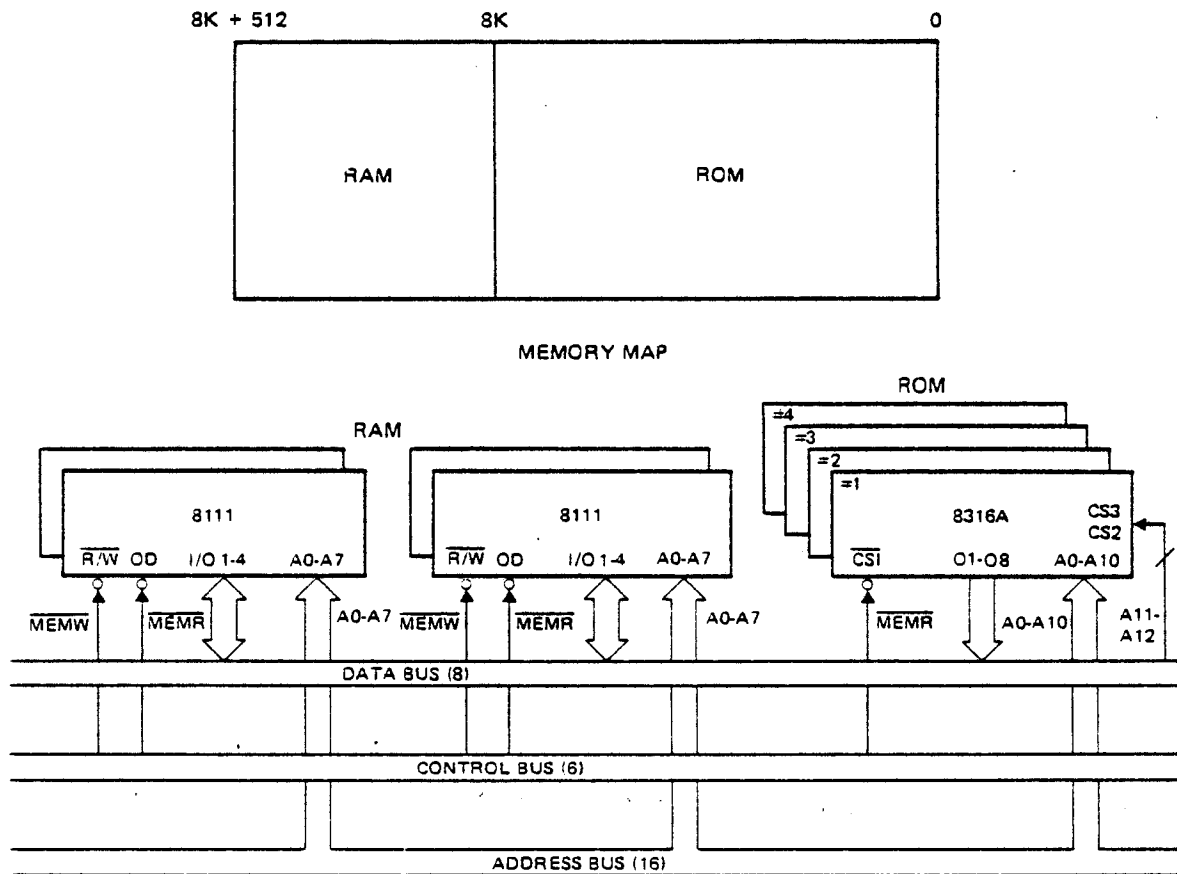

Figure 3-7. Typical Memory Interface

## I/O INTERFACE

### General Theory

As in any computer based system, the 8080 CPU must be able to communicate with devices or structures that exist outside its normal memory array. Devices like keyboards, paper tape, floppy disks, printers, displays and other control structures are used to input information into the 8080 CPU and display or store the results of the computational activity.

Probably the most important and strongest feature of the 8080 Microcomputer System is the flexibility and power of its I/O structure and the components that support it. There are many ways to structure the I/O array so that it will "fit" the total system environment to maximize efficiency and minimize component count.

The basic operation of the I/O structure can best be viewed as an array of single byte memory locations that can be Read from or Written into. The 8080 CPU has special instructions devoted to managing such transfers (IN, OUT). These instructions generally isolate memory and I/O arrays so that memory address space is not effected by the I/O structure and the general concept is that of a simple transfer to or from the Accumulator with an addressed "PORT". Another method of I/O architecture is to treat the I/O structure as part of the Memory array. This is generally referred to as "Memory Mapped I/O" and provides the designer with a powerful new "instruction set" devoted to I/O manipulation.

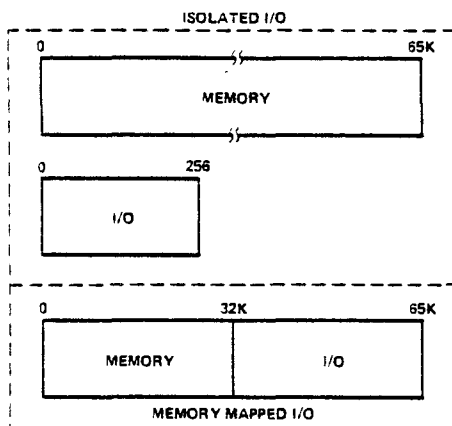

Figure 3-8. Memory/I/O Mapping.

### Isolated I/O

In Figure 3-9 the system control signals, previously detailed in this chapter, are shown. This type of I/O architecture separates the memory address space from the I/O address space and uses a conceptually simple transfer to or from Accumulator technique. Such an architecture is easy to understand because I/O communicates only with the Accumulator using the IN or OUT instructions. Also because of the isolation of memory and I/O, the full address space (65K) is unaffected by I/O addressing.

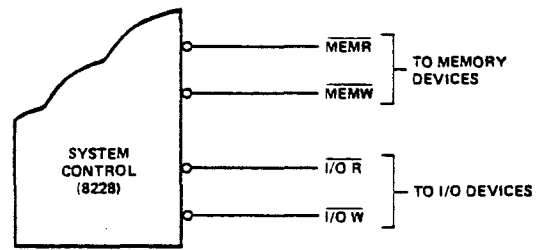

Figure 3-9. Isolated I/O.

### Memory Mapped I/O

By assigning an area of memory address space as I/O a powerful architecture can be developed that can manipulate I/O using the same instructions that are used to manipulate memory locations. Thus, a "new" instruction set is created that is devoted to I/O handling.

As shown in Figure 3-10, new control signals are generated by gating the MEMR and MEMW signals with A<sub>15</sub>, the most significant address bit. The new I/O control signals connect in exactly the same manner as Isolated I/O, thus the system bus characteristics are unchanged.

By assigning A<sub>15</sub> as the I/O "flag", a simple method of I/O discipline is maintained:

If A<sub>15</sub> is a "zero" then Memory is active.

If A<sub>15</sub> is a "one" then I/O is active.

Other address bits can also be used for this function. A<sub>15</sub> was chosen because it is the most significant address bit so it is easier to control with software and because it still allows memory addressing of 32K.

I/O devices are still considered addressed "ports" but instead of the Accumulator as the only transfer medium any of the internal registers can be used. All instructions that could be used to operate on memory locations can be used in I/O.

#### Examples:

|          |                                 |
|----------|---------------------------------|
| MOV r, M | (Input Port to any Register)    |
| MOV M, r | (Output any Register to Port)   |
| MVI M    | (Output immediate data to Port) |
| LDA      | (Input to ACC)                  |
| STA      | (Output from ACC to Port)       |
| LHLD     | (16 Bit Input)                  |
| SHLD     | (16 Bit Output)                 |
| ADD M    | (Add Port to ACC)               |
| ANA M    | ("AND" Port with ACC)           |

It is easy to see that from the list of possible "new" instructions that this type of I/O architecture could have a drastic effect on increased system throughput. It is conceptually more difficult to understand than Isolated I/O and it does limit memory address space, but Memory Mapped I/O can mean a significant increase in overall speed and at the same time reducing required program memory area.

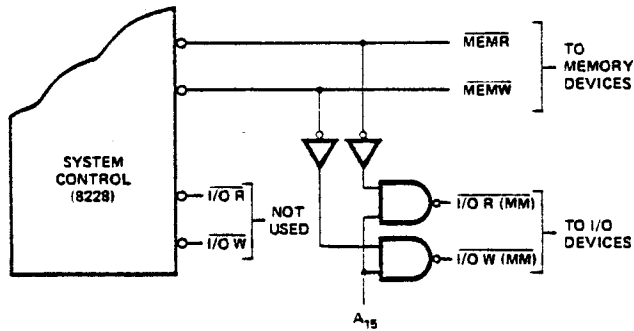

Figure 3-10. Memory Mapped I/O.

### I/O Addressing

With both systems of I/O structure the addressing of each device can be configured to optimize efficiency and reduce component count. One method, the most common, is to decode the address bus into exclusive "chip selects" that enable the addressed I/O device, similar to generating chip-selects in memory arrays.

Another method is called "linear select". In this method, instead of decoding the Address Bus, a singular bit from the bus is assigned as the exclusive enable for a specific I/O device. This method, of course, limits the number of I/O devices that can be addressed but eliminates the need for extra decoders, an important consideration in small system design.

A simple example illustrates the power of such a flexible I/O structure. The first example illustrates the format of the second byte of the IN or OUT instruction using the Isolated I/O technique. The devices used are Intel<sup>®</sup>8255 Programmable Peripheral Interface units and are linear selected. Each device has three ports and from the format it can be seen that six devices can be addressed without additional decoders.

#### EXAMPLE #1

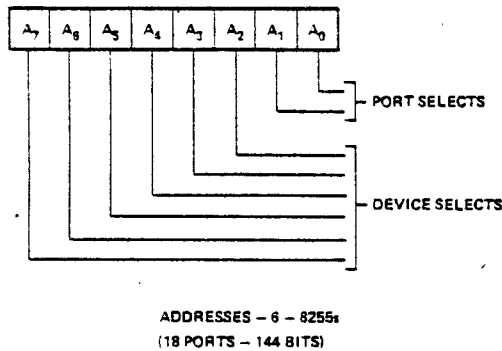

Figure 3-11. Isolated I/O - (Linear Select) (8255)

The second example uses Memory Mapped I/O and linear select to show how thirteen devices (8255) can be addressed without the use of extra decoders. The format shown could be the second and third bytes of the LDA or STA instructions or any other instructions used to manipulate I/O using the Memory Mapped technique.

It is easy to see that such a flexible I/O structure, that can be "tailored" to the overall system environment, provides the designer with a powerful tool to optimize efficiency and minimize component count.

#### EXAMPLE #2

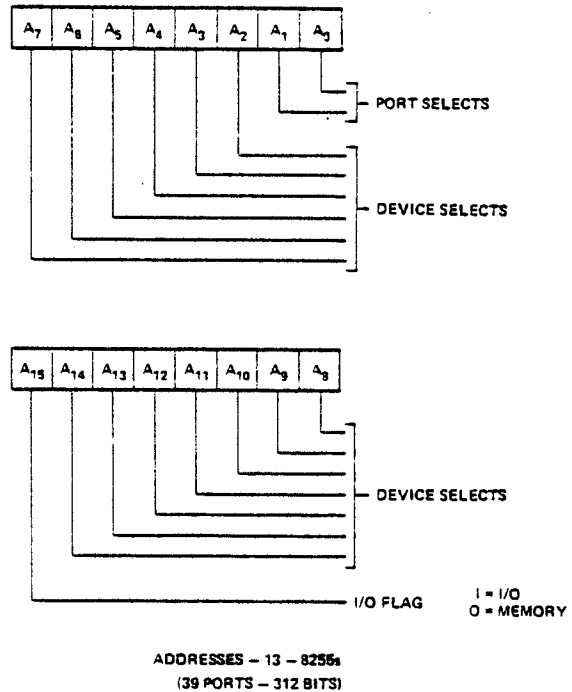

Figure 3-12. Memory Mapped I/O - (Linear Select) (8255)

### I/O Interface Example

In Figure 3-16 a typical I/O system is shown that uses a variety of devices (8212, 8251 and 8255). It could be used to interface the peripherals around an intelligent CRT terminals; keyboards, display, and communication interface. Another application could be in a process controller to interface sensors, relays, and motor controls. The limitation of the application area for such a circuit is solely that of the designers imagination.

The I/O structure shown interfaces to the 8080 CPU using the bus architecture developed previously in this chapter. Either Isolated or Memory Mapped techniques can be used, depending on the system I/O environment.

The 8251 provides a serial data communication interface so that the system can transmit and receive data over communication links such as telephone lines.

The three 8212s can be used to drive long lines or LED indicators due to their high drive capability. (15mA)

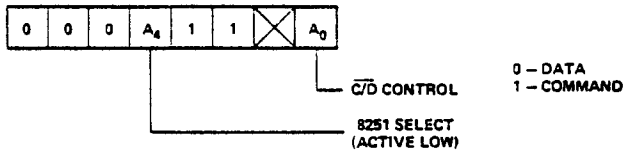

Figure 3-13. 8251 Format.

The two (2) 8255s provide twenty four bits each of programmable I/O data and control so that keyboards, sensors, paper tape, etc., can be interfaced to the system.

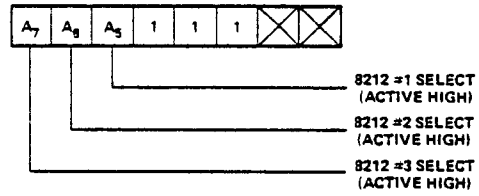

Figure 3-15. 8212 Format.

Addressing the structure is described in the formats illustrated in Figures 3-13, 3-14, 3-15. Linear Select is used so that no decoders are required thus, each device has an exclusive "enable bit".

The example shows how a powerful yet flexible I/O structure can be created using a minimum component count with devices that are all members of the 8080 Microcomputer System.

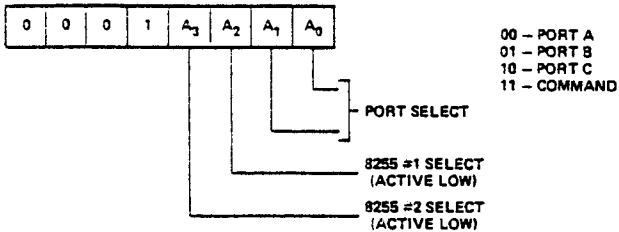

Figure 3-14. 8255 Format.

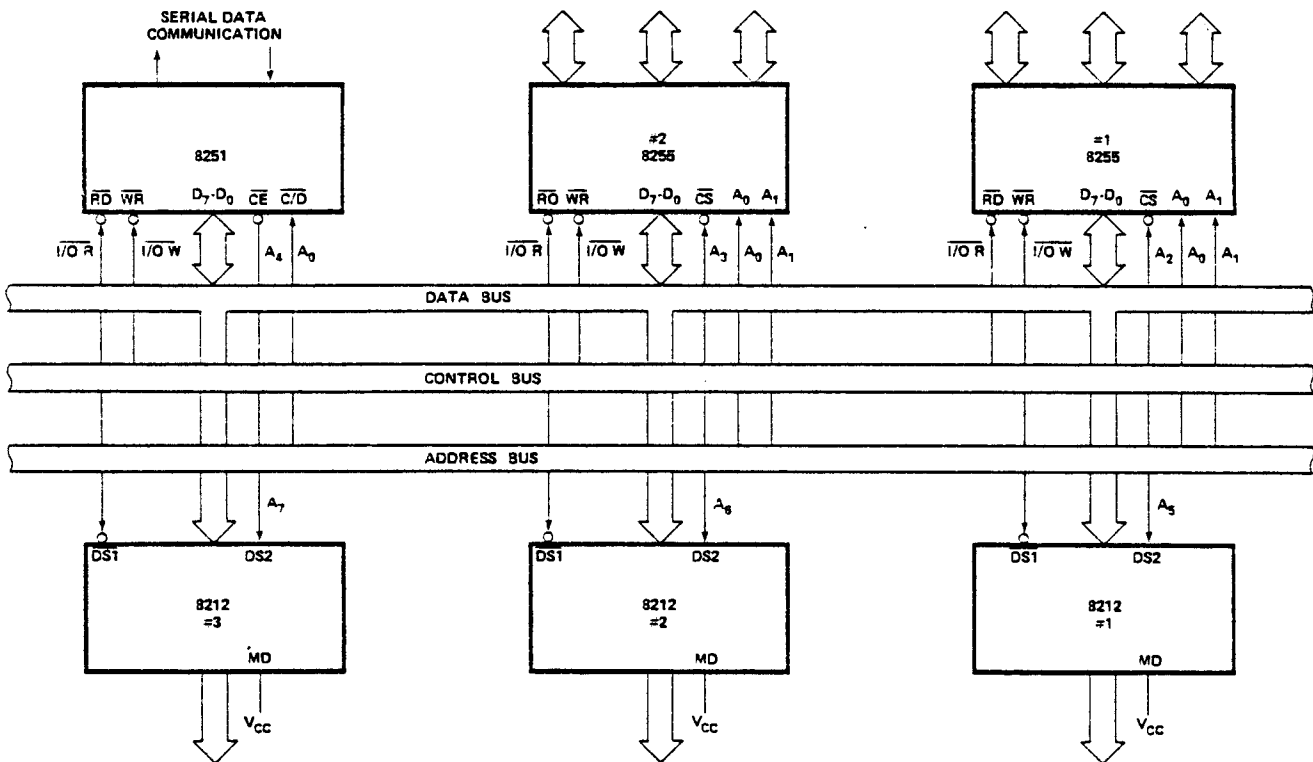

Figure 3-16. Typical I/O Interface.



## CHAPTER 4 INSTRUCTION SET

A computer, no matter how sophisticated, can only do what it is "told" to do. One "tells" the computer what to do via a series of coded instructions referred to as a **Program**. The realm of the programmer is referred to as **Software**, in contrast to the **Hardware** that comprises the actual computer equipment. A computer's software refers to all of the programs that have been written for that computer.

When a computer is designed, the engineers provide the Central Processing Unit (CPU) with the ability to perform a particular set of operations. The CPU is designed such that a specific operation is performed when the CPU control logic decodes a particular instruction. Consequently, the operations that can be performed by a CPU define the computer's **Instruction Set**.

Each computer instruction allows the programmer to initiate the performance of a specific operation. All computers implement certain arithmetic operations in their instruction set, such as an instruction to add the contents of two registers. Often logical operations (e.g., OR the contents of two registers) and register operate instructions (e.g., increment a register) are included in the instruction set. A computer's instruction set will also have instructions that move data between registers, between a register and memory, and between a register and an I/O device. Most instruction sets also provide **Conditional Instructions**. A conditional instruction specifies an operation to be performed only if certain conditions have been met; for example, jump to a particular instruction if the result of the last operation was zero. Conditional instructions provide a program with a decision-making capability.

By logically organizing a sequence of instructions into a coherent program, the programmer can "tell" the computer to perform a very specific and useful function.

The computer, however, can only execute programs whose instructions are in a binary coded form (i.e., a series of 1's and 0's), that is called **Machine Code**. Because it would be extremely cumbersome to program in machine code, programming languages have been developed. There

are programs available which convert the programming language instructions into machine code that can be interpreted by the processor.

One type of programming language is **Assembly Language**. A unique assembly language mnemonic is assigned to each of the computer's instructions. The programmer can write a program (called the **Source Program**) using these mnemonics and certain operands; the source program is then converted into machine instructions (called the **Object Code**). Each assembly language instruction is converted into one machine code instruction (1 or more bytes) by an **Assembler** program. Assembly languages are usually machine dependent (i.e., they are usually able to run on only one type of computer).

### THE 8080 INSTRUCTION SET

The 8080 instruction set includes five different types of instructions:

- **Data Transfer Group**—move data between registers or between memory and registers
- **Arithmetic Group**—add, subtract, increment or decrement data in registers or in memory
- **Logical Group**—AND, OR, EXCLUSIVE-OR, compare, rotate or complement data in registers or in memory
- **Branch Group**—conditional and unconditional jump instructions, subroutine call instructions and return instructions
- **Stack, I/O and Machine Control Group**—includes I/O instructions, as well as instructions for maintaining the stack and internal control flags.

### Instruction and Data Formats:

Memory for the 8080 is organized into 8-bit quantities, called **Bytes**. Each byte has a unique 16-bit binary address corresponding to its sequential position in memory.

The 8080 can directly address up to 65,536 bytes of memory, which may consist of both read-only memory (ROM) elements and random-access memory (RAM) elements (read/write memory).

Data in the 8080 is stored in the form of 8-bit binary integers:

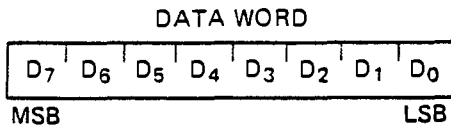

When a register or data word contains a binary number, it is necessary to establish the order in which the bits of the number are written. In the Intel 8080, BIT 0 is referred to as the **Least Significant Bit (LSB)**, and BIT 7 (of an 8 bit number) is referred to as the **Most Significant Bit (MSB)**.

The 8080 program instructions may be one, two or three bytes in length. Multiple byte instructions must be stored in successive memory locations; the address of the first byte is always used as the address of the instructions. The exact instruction format will depend on the particular operation to be executed.

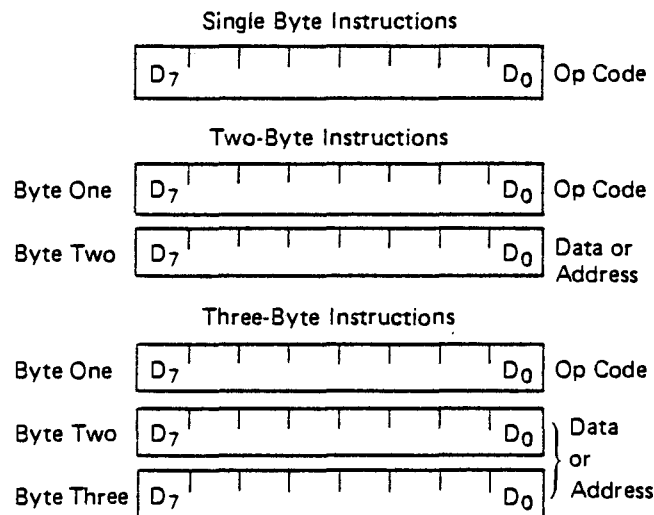

### Addressing Modes:

Often the data that is to be operated on is stored in memory. When multi-byte numeric data is used, the data, like instructions, is stored in successive memory locations, with the least significant byte first, followed by increasingly significant bytes. The 8080 has four different modes for addressing data stored in memory or in registers:

- **Direct** – Bytes 2 and 3 of the instruction contain the exact memory address of the data item (the low-order bits of the address are in byte 2, the high-order bits in byte 3).
- **Register** – The instruction specifies the register or register-pair in which the data is located.
- **Register Indirect** – The instruction specifies a register-pair which contains the memory

address where the data is located (the high-order bits of the address are in the first register of the pair, the low-order bits in the second).

- **Immediate** – The instruction contains the data itself. This is either an 8-bit quantity or a 16-bit quantity (least significant byte first, most significant byte second).

Unless directed by an interrupt or branch instruction, the execution of instructions proceeds through consecutively increasing memory locations. A branch instruction can specify the address of the next instruction to be executed in one of two ways:

- **Direct** – The branch instruction contains the address of the next instruction to be executed. (Except for the 'RST' instruction, byte 2 contains the low-order address and byte 3 the high-order address.)
- **Register indirect** – The branch instruction indicates a register-pair which contains the address of the next instruction to be executed. (The high-order bits of the address are in the first register of the pair, the low-order bits in the second.)

The RST instruction is a special one-byte call instruction (usually used during interrupt sequences). RST includes a three-bit field; program control is transferred to the instruction whose address is eight times the contents of this three-bit field.

### Condition Flags:

There are five condition flags associated with the execution of instructions on the 8080. They are Zero, Sign, Parity, Carry, and Auxiliary Carry, and are each represented by a 1-bit register in the CPU. A flag is "set" by forcing the bit to 1; "reset" by forcing the bit to 0.

Unless indicated otherwise, when an instruction affects a flag, it affects it in the following manner:

- |         |   |
|---------|---|
| Zero:   | If the result of an instruction has the value 0, this flag is set; otherwise it is reset.   |
| Sign:   | If the most significant bit of the result of the operation has the value 1, this flag is set; otherwise it is reset.  |
| Parity: | If the modulo 2 sum of the bits of the result of the operation is 0, (i.e., if the result has even parity), this flag is set; otherwise it is reset (i.e., if the result has odd parity). |
| Carry:  | If the instruction resulted in a carry (from addition), or a borrow (from subtraction or a comparison) out of the high-order bit, this flag is set; otherwise it is reset.                |

**Auxiliary Carry:** If the instruction caused a carry out of bit 3 and into bit 4 of the resulting value, the auxiliary carry is set; otherwise it is reset. This flag is affected by single precision additions, subtractions, increments, decrements, comparisons, and logical operations, but is principally used with additions and increments preceding a DAA (Decimal Adjust Accumulator) instruction.

**Symbols and Abbreviations:**

The following symbols and abbreviations are used in the subsequent description of the 8080 instructions:

| SYMBOLS     | MEANING   |
|-------------|---|
| accumulator | Register A  |
| addr        | 16-bit address quantity   |
| data        | 8-bit data quantity   |
| data 16     | 16-bit data quantity  |
| byte 2      | The second byte of the instruction  |
| byte 3      | The third byte of the instruction   |
| port        | 8-bit address of an I/O device  |
| r,r1,r2     | One of the registers A,B,C,D,E,H,L  |
| DDD,SSS     | The bit pattern designating one of the registers A,B,C,D,E,H,L (DDD=destination, SSS=source): |

| DDD or SSS | REGISTER NAME |
|------------|---------------|
| 111        | A             |
| 000        | B             |
| 001        | C             |
| 010        | D             |
| 011        | E             |
| 100        | H             |
| 101        | L             |

**rp** One of the register pairs:  
 B represents the B,C pair with B as the high-order register and C as the low-order register;  
 D represents the D,E pair with D as the high-order register and E as the low-order register;  
 H represents the H,L pair with H as the high-order register and L as the low-order register;  
 SP represents the 16-bit stack pointer register.

**RP** The bit pattern designating one of the register pairs B,D,H,SP:

| RP | REGISTER PAIR |
|----|---------------|
| 00 | B-C           |
| 01 | D-E           |
| 10 | H-L           |
| 11 | SP            |

|                |  |
|----------------|--|
| rh             | The first (high-order) register of a designated register pair.   |
| rl             | The second (low-order) register of a designated register pair.   |
| PC             | 16-bit program counter register (PCH and PCL are used to refer to the high-order and low-order 8 bits respectively). |
| SP             | 16-bit stack pointer register (SPH and SPL are used to refer to the high-order and low-order 8 bits respectively).   |
| r <sub>m</sub> | Bit m of the register r (bits are number 7 through 0 from left to right).  |
| Z,S,P,CY,AC    | The condition flags:<br>Zero,<br>Sign,<br>Parity,<br>Carry,<br>and Auxiliary Carry, respectively.                    |
| ( )            | The contents of the memory location or registers enclosed in the parentheses.  |
| ←              | "Is transferred to"  |
| ∧              | Logical AND  |
| ⊕              | Exclusive OR   |
| ∨              | Inclusive OR   |
| +              | Addition   |
| -              | Two's complement subtraction   |
| *              | Multiplication   |
| ↔              | "Is exchanged with"  |
| —              | The one's complement (e.g., $\overline{A}$ )   |
| n              | The restart number 0 through 7   |
| NNN            | The binary representation 000 through 111 for restart number 0 through 7 respectively.                               |

**Description Format:**

The following pages provide a detailed description of the instruction set of the 8080. Each instruction is described in the following manner:

1. The MAC 80 assembler format, consisting of the instruction mnemonic and operand fields, is printed in **BOLDFACE** on the left side of the first line.
2. The name of the instruction is enclosed in parenthesis on the right side of the first line.
3. The next line(s) contain a symbolic description of the operation of the instruction.
4. This is followed by a narrative description of the operation of the instruction.
5. The following line(s) contain the binary fields and patterns that comprise the machine instruction.

6. The last four lines contain incidental information about the execution of the instruction. The number of machine cycles and states required to execute the instruction are listed first. If the instruction has two possible execution times, as in a Conditional Jump, both times will be listed, separated by a slash. Next, any significant data addressing modes (see Page 4-2) are listed. The last line lists any of the five Flags that are affected by the execution of the instruction.

### Data Transfer Group:

This group of instructions transfers data to and from registers and memory. Condition flags are not affected by any instruction in this group.

#### MOV r1, r2 (Move Register)

$(r1) \leftarrow (r2)$

The content of register r2 is moved to register r1.

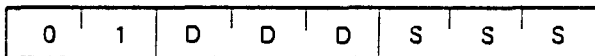

Cycles: 1  
 States: 5  
 Addressing: register  
 Flags: none

#### MOV r, M (Move from memory)

$(r) \leftarrow ((H) (L))$

The content of the memory location, whose address is in registers H and L, is moved to register r.

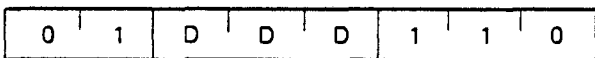

Cycles: 2  
 States: 7  
 Addressing: reg. indirect  
 Flags: none

#### MOV M, r (Move to memory)

$((H) (L)) \leftarrow (r)$

The content of register r is moved to the memory location whose address is in registers H and L.

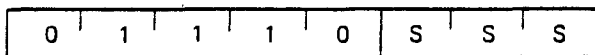

Cycles: 2  
 States: 7  
 Addressing: reg. indirect  
 Flags: none

#### MVI r, data (Move Immediate)

$(r) \leftarrow (\text{byte } 2)$

The content of byte 2 of the instruction is moved to register r.

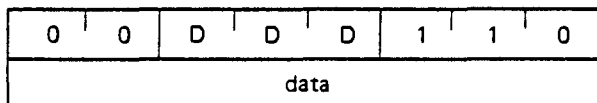

Cycles: 2  
 States: 7  
 Addressing: immediate  
 Flags: none

#### MVI M, data (Move to memory immediate)

$((H) (L)) \leftarrow (\text{byte } 2)$

The content of byte 2 of the instruction is moved to the memory location whose address is in registers H and L.

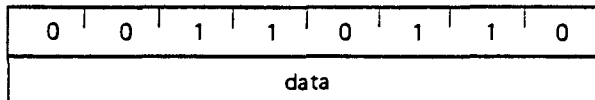

Cycles: 3  
 States: 10  
 Addressing: immed./reg. indirect  
 Flags: none

#### LXI rp, data 16 (Load register pair immediate)

$(rh) \leftarrow (\text{byte } 3),$

$(rl) \leftarrow (\text{byte } 2)$

Byte 3 of the instruction is moved into the high-order register (rh) of the register pair rp. Byte 2 of the instruction is moved into the low-order register (rl) of the register pair rp.

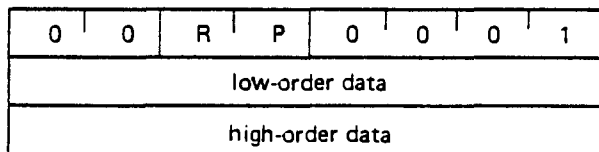

Cycles: 3  
 States: 10  
 Addressing: immediate  
 Flags: none

**LDA addr** (Load Accumulator direct)  
 $(A) \leftarrow ((\text{byte 3})(\text{byte 2}))$   
 The content of the memory location, whose address is specified in byte 2 and byte 3 of the instruction, is moved to register A.

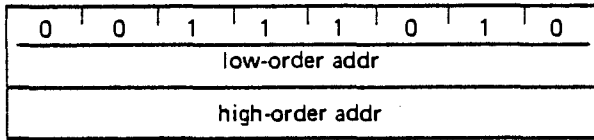

Cycles: 4  
 States: 13  
 Addressing: direct  
 Flags: none

**STA addr** (Store Accumulator direct)  
 $((\text{byte 3})(\text{byte 2})) \leftarrow (A)$   
 The content of the accumulator is moved to the memory location whose address is specified in byte 2 and byte 3 of the instruction.

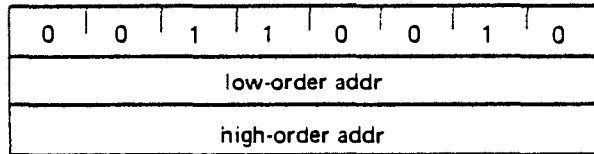

Cycles: 4  
 States: 13  
 Addressing: direct  
 Flags: none

**LHLD addr** (Load H and L direct)  
 $(L) \leftarrow ((\text{byte 3})(\text{byte 2}))$   
 $(H) \leftarrow ((\text{byte 3})(\text{byte 2}) + 1)$   
 The content of the memory location, whose address is specified in byte 2 and byte 3 of the instruction, is moved to register L. The content of the memory location at the succeeding address is moved to register H.

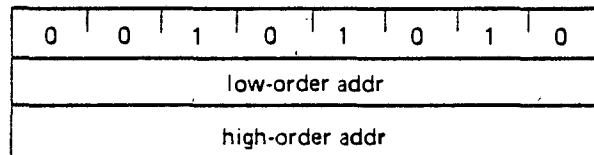

Cycles: 5  
 States: 16  
 Addressing: direct  
 Flags: none

**SHLD addr** (Store H and L direct)  
 $((\text{byte 3})(\text{byte 2})) \leftarrow (L)$   
 $((\text{byte 3})(\text{byte 2}) + 1) \leftarrow (H)$   
 The content of register L is moved to the memory location whose address is specified in byte 2 and byte 3. The content of register H is moved to the succeeding memory location.

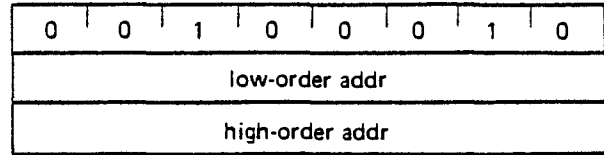

Cycles: 5  
 States: 16  
 Addressing: direct  
 Flags: none

**LDAX rp** (Load accumulator indirect)  
 $(A) \leftarrow ((rp))$   
 The content of the memory location, whose address is in the register pair rp, is moved to register A. Note: only register pairs rp=B (registers B and C) or rp=D (registers D and E) may be specified.



Cycles: 2  
 States: 7  
 Addressing: reg. indirect  
 Flags: none

**STAX rp** (Store accumulator indirect)  
 $((rp)) \leftarrow (A)$   
 The content of register A is moved to the memory location whose address is in the register pair rp. Note: only register pairs rp=B (registers B and C) or rp=D (registers D and E) may be specified.

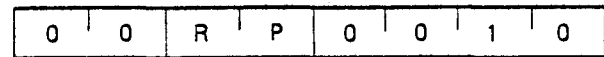

Cycles: 2  
 States: 7  
 Addressing: reg. indirect  
 Flags: none

**XCHG** (Exchange H and L with D and E)  
 $(H) \leftrightarrow (D)$   
 $(L) \leftrightarrow (E)$   
 The contents of registers H and L are exchanged with the contents of registers D and E.

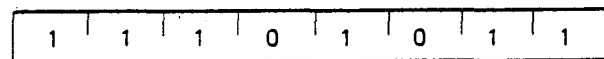

Cycles: 1  
 States: 4  
 Addressing: register  
 Flags: none

## Arithmetic Group:

This group of instructions performs arithmetic operations on data in registers and memory.

Unless indicated otherwise, all instructions in this group affect the Zero, Sign, Parity, Carry, and Auxiliary Carry flags according to the standard rules.

All subtraction operations are performed via two's complement arithmetic and set the carry flag to one to indicate a borrow and clear it to indicate no borrow.

### ADD r (Add Register)

$$(A) \leftarrow (A) + (r)$$

The content of register r is added to the content of the accumulator. The result is placed in the accumulator.

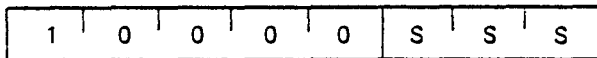

Cycles: 1  
States: 4  
Addressing: register  
Flags: Z,S,P,CY,AC

### ADD M (Add memory)

$$(A) \leftarrow (A) + ((H) (L))$$

The content of the memory location whose address is contained in the H and L registers is added to the content of the accumulator. The result is placed in the accumulator.

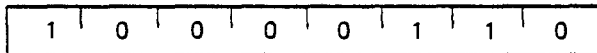

Cycles: 2  
States: 7  
Addressing: reg. indirect  
Flags: Z,S,P,CY,AC

### ADI data (Add immediate)

$$(A) \leftarrow (A) + (\text{byte 2})$$

The content of the second byte of the instruction is added to the content of the accumulator. The result is placed in the accumulator.

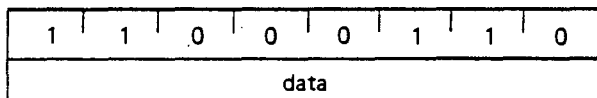

Cycles: 2  
States: 7  
Addressing: immediate  
Flags: Z,S,P,CY,AC

### ADC r (Add Register with carry)

$$(A) \leftarrow (A) + (r) + (CY)$$

The content of register r and the content of the carry bit are added to the content of the accumulator. The result is placed in the accumulator.

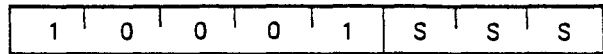

Cycles: 1  
States: 4  
Addressing: register  
Flags: Z,S,P,CY,AC

### ADC M (Add memory with carry)

$$(A) \leftarrow (A) + ((H) (L)) + (CY)$$

The content of the memory location whose address is contained in the H and L registers and the content of the CY flag are added to the accumulator. The result is placed in the accumulator.

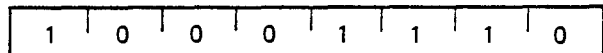

Cycles: 2  
States: 7  
Addressing: reg. indirect  
Flags: Z,S,P,CY,AC

### ACI data (Add immediate with carry)

$$(A) \leftarrow (A) + (\text{byte 2}) + (CY)$$

The content of the second byte of the instruction and the content of the CY flag are added to the contents of the accumulator. The result is placed in the accumulator.

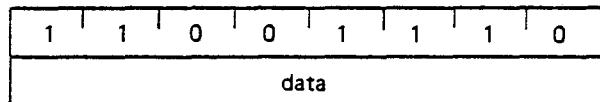

Cycles: 2  
States: 7  
Addressing: immediate  
Flags: Z,S,P,CY,AC

### SUB r (Subtract Register)

$$(A) \leftarrow (A) - (r)$$

The content of register r is subtracted from the content of the accumulator. The result is placed in the accumulator.

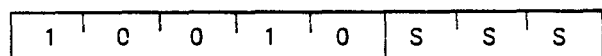

Cycles: 1  
States: 4  
Addressing: register  
Flags: Z,S,P,CY,AC

**SUB M** (Subtract memory)

$$(A) \leftarrow (A) - ((H) (L))$$

The content of the memory location whose address is contained in the H and L registers is subtracted from the content of the accumulator. The result is placed in the accumulator.



Cycles: 2  
 States: 7  
 Addressing: reg. indirect  
 Flags: Z,S,P,CY,AC

**SBI data** (Subtract immediate with borrow)

$$(A) \leftarrow (A) - (\text{byte 2}) - (CY)$$

The contents of the second byte of the instruction and the contents of the CY flag are both subtracted from the accumulator. The result is placed in the accumulator.

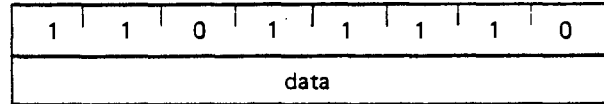

Cycles: 2  
 States: 7  
 Addressing: immediate  
 Flags: Z,S,P,CY,AC

**SUI data** (Subtract immediate)

$$(A) \leftarrow (A) - (\text{byte 2})$$

The content of the second byte of the instruction is subtracted from the content of the accumulator. The result is placed in the accumulator.

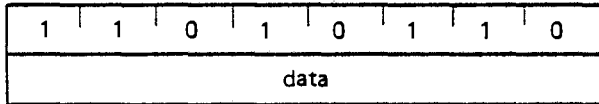

Cycles: 2  
 States: 7  
 Addressing: immediate  
 Flags: Z,S,P,CY,AC

**INR r** (Increment Register)

$$(r) \leftarrow (r) + 1$$

The content of register r is incremented by one. Note: All condition flags except CY are affected.

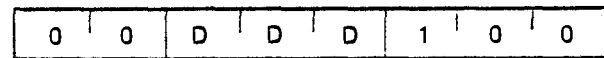

Cycles: 1  
 States: 5  
 Addressing: register  
 Flags: Z,S,P,AC

**SBB r** (Subtract Register with borrow)

$$(A) \leftarrow (A) - (r) - (CY)$$

The content of register r and the content of the CY flag are both subtracted from the accumulator. The result is placed in the accumulator.

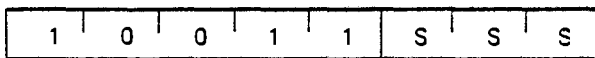

Cycles: 1  
 States: 4  
 Addressing: register  
 Flags: Z,S,P,CY,AC

**INR M** (Increment memory)

$$((H) (L)) \leftarrow ((H) (L)) + 1$$

The content of the memory location whose address is contained in the H and L registers is incremented by one. Note: All condition flags except CY are affected.

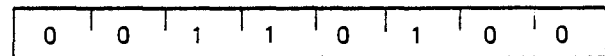

Cycles: 3  
 States: 10  
 Addressing: reg. indirect  
 Flags: Z,S,P,AC

**SBB M** (Subtract memory with borrow)

$$(A) \leftarrow (A) - ((H) (L)) - (CY)$$

The content of the memory location whose address is contained in the H and L registers and the content of the CY flag are both subtracted from the accumulator. The result is placed in the accumulator.

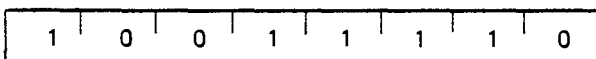

Cycles: 2  
 States: 7  
 Addressing: reg. indirect  
 Flags: Z,S,P,CY,AC

**DCR r** (Decrement Register)

$$(r) \leftarrow (r) - 1$$

The content of register r is decremented by one. Note: All condition flags except CY are affected.

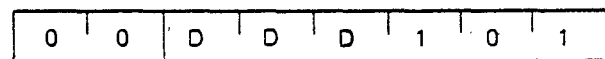

Cycles: 1  
 States: 5  
 Addressing: register  
 Flags: Z,S,P,AC

**DCR M** (Decrement memory)

$$((H) (L)) \leftarrow ((H) (L)) - 1$$

The content of the memory location whose address is contained in the H and L registers is decremented by one. Note: All condition flags **except CY** are affected.

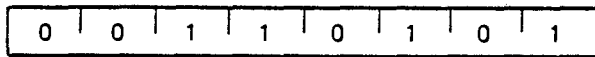

Cycles: 3  
 States: 10  
 Addressing: reg. indirect  
 Flags: Z,S,P,AC

**INX rp** (Increment register pair)

$$(rh) (rl) \leftarrow (rh) (rl) + 1$$

The content of the register pair rp is incremented by one. Note: **No condition flags are affected.**

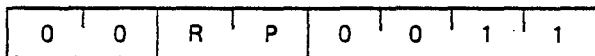

Cycles: 1  
 States: 5  
 Addressing: register  
 Flags: none

**DCX rp** (Decrement register pair)

$$(rh) (rl) \leftarrow (rh) (rl) - 1$$

The content of the register pair rp is decremented by one. Note: **No condition flags are affected.**

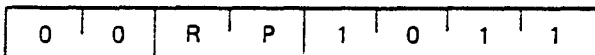

Cycles: 1  
 States: 5  
 Addressing: register  
 Flags: none

**DAD rp** (Add register pair to H and L)

$$(H) (L) \leftarrow (H) (L) + (rh) (rl)$$

The content of the register pair rp is added to the content of the register pair H and L. The result is placed in the register pair H and L. Note: **Only the CY flag is affected.** It is set if there is a carry out of the double precision add; otherwise it is reset.

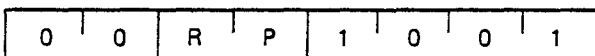

Cycles: 3  
 States: 10  
 Addressing: register  
 Flags: CY

**DAA** (Decimal Adjust Accumulator)

The eight-bit number in the accumulator is adjusted to form two four-bit Binary-Coded-Decimal digits by the following process:

1. If the value of the least significant 4 bits of the accumulator is greater than 9 or if the AC flag is set, 6 is added to the accumulator.
2. If the value of the most significant 4 bits of the accumulator is now greater than 9, or if the CY flag is set, 6 is added to the most significant 4 bits of the accumulator.

NOTE: All flags are affected.

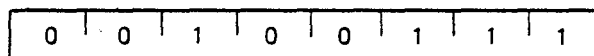

Cycles: 1  
 States: 4  
 Flags: Z,S,P,CY,AC

**Logical Group:**

This group of instructions performs logical (Boolean) operations on data in registers and memory and on condition flags.

Unless indicated otherwise, all instructions in this group affect the Zero, Sign, Parity, Auxiliary Carry, and Carry flags according to the standard rules.

**ANA r** (AND Register)

$$(A) \leftarrow (A) \wedge (r)$$

The content of register r is logically anded with the content of the accumulator. The result is placed in the accumulator. **The CY flag is cleared.**

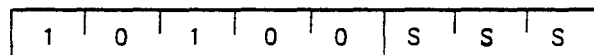

Cycles: 1  
 States: 4  
 Addressing: register  
 Flags: Z,S,P,CY,AC

**ANA M** (AND memory)

$$(A) \leftarrow (A) \wedge ((H) (L))$$

The contents of the memory location whose address is contained in the H and L registers is logically anded with the content of the accumulator. The result is placed in the accumulator. **The CY flag is cleared.**

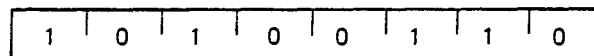

Cycles: 2  
 States: 7  
 Addressing: reg. indirect  
 Flags: Z,S,P,CY,AC



**ANI data** (AND immediate)

$$(A) \leftarrow (A) \wedge (\text{byte } 2)$$

The content of the second byte of the instruction is logically anded with the contents of the accumulator. The result is placed in the accumulator. The CY and AC flags are cleared.

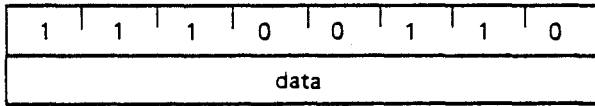

Cycles: 2  
 States: 7  
 Addressing: immediate  
 Flags: Z,S,P,CY,AC

**XRA r** (Exclusive OR Register)

$$(A) \leftarrow (A) \nabla (r)$$

The content of register r is exclusive-or'd with the content of the accumulator. The result is placed in the accumulator. The CY and AC flags are cleared.

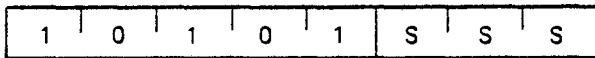

Cycles: 1  
 States: 4  
 Addressing: register  
 Flags: Z,S,P,CY,AC

**XRA M** (Exclusive OR Memory)

$$(A) \leftarrow (A) \nabla ((H) (L))$$

The content of the memory location whose address is contained in the H and L registers is exclusive-OR'd with the content of the accumulator. The result is placed in the accumulator. The CY and AC flags are cleared.

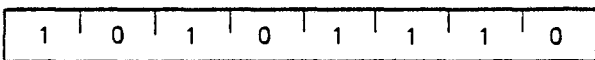

Cycles: 2  
 States: 7  
 Addressing: reg. indirect  
 Flags: Z,S,P,CY,AC

**XRI data** (Exclusive OR immediate)

$$(A) \leftarrow (A) \nabla (\text{byte } 2)$$

The content of the second byte of the instruction is exclusive-OR'd with the content of the accumulator. The result is placed in the accumulator. The CY and AC flags are cleared.

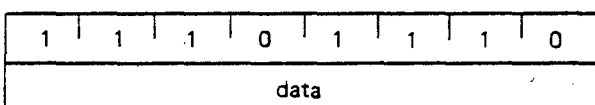

Cycles: 2  
 States: 7  
 Addressing: immediate  
 Flags: Z,S,P,CY,AC

**ORA r** (OR Register)

$$(A) \leftarrow (A) \vee (r)$$

The content of register r is inclusive-OR'd with the content of the accumulator. The result is placed in the accumulator. The CY and AC flags are cleared.



Cycles: 1  
 States: 4  
 Addressing: register  
 Flags: Z,S,P,CY,AC

**ORA M** (OR memory)

$$(A) \leftarrow (A) \vee ((H) (L))$$

The content of the memory location whose address is contained in the H and L registers is inclusive-OR'd with the content of the accumulator. The result is placed in the accumulator. The CY and AC flags are cleared.



Cycles: 2  
 States: 7  
 Addressing: reg. indirect  
 Flags: Z,S,P,CY,AC

**ORI data** (OR Immediate)

$$(A) \leftarrow (A) \vee (\text{byte } 2)$$

The content of the second byte of the instruction is inclusive-OR'd with the content of the accumulator. The result is placed in the accumulator. The CY and AC flags are cleared.

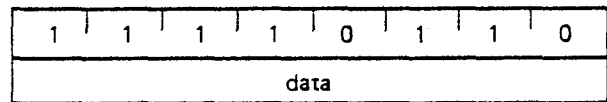

Cycles: 2  
 States: 7  
 Addressing: immediate  
 Flags: Z,S,P,CY,AC

**CMP r** (Compare Register)

$$(A) - (r)$$

The content of register r is subtracted from the accumulator. The accumulator remains unchanged. The condition flags are set as a result of the subtraction. The Z flag is set to 1 if  $(A) = (r)$ . The CY flag is set to 1 if  $(A) < (r)$ .

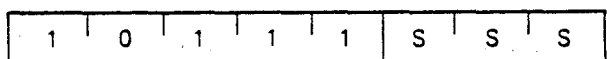

Cycles: 1  
 States: 4  
 Addressing: register  
 Flags: Z,S,P,CY,AC

**CMP M** (Compare memory)

$(A) - ((H) (L))$

The content of the memory location whose address is contained in the H and L registers is subtracted from the accumulator. The accumulator remains unchanged. The condition flags are set as a result of the subtraction. The Z flag is set to 1 if  $(A) = ((H) (L))$ . The CY flag is set to 1 if  $(A) < ((H) (L))$ .



Cycles: 2  
 States: 7  
 Addressing: reg. indirect  
 Flags: Z,S,P,CY,AC

**CPI data** (Compare immediate)

$(A) - (\text{byte 2})$

The content of the second byte of the instruction is subtracted from the accumulator. The condition flags are set by the result of the subtraction. The Z flag is set to 1 if  $(A) = (\text{byte 2})$ . The CY flag is set to 1 if  $(A) < (\text{byte 2})$ .

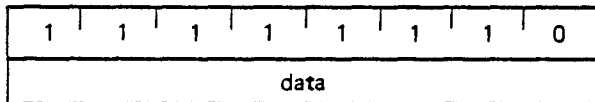

Cycles: 2  
 States: 7  
 Addressing: immediate  
 Flags: Z,S,P,CY,AC

**RLC** (Rotate left)

$(A_{n+1}) \leftarrow (A_n) ; (A_0) \leftarrow (A_7)$   
 $(CY) \leftarrow (A_7)$

The content of the accumulator is rotated left one position. The low order bit and the CY flag are both set to the value shifted out of the high order bit position. Only the CY flag is affected.

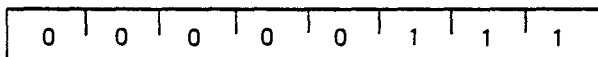

Cycles: 1  
 States: 4  
 Flags: CY

**RRC** (Rotate right)

$(A_n) \leftarrow (A_{n-1}) ; (A_7) \leftarrow (A_0)$   
 $(CY) \leftarrow (A_0)$

The content of the accumulator is rotated right one position. The high order bit and the CY flag are both set to the value shifted out of the low order bit position. Only the CY flag is affected.

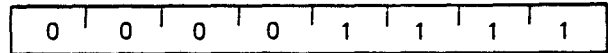

Cycles: 1  
 States: 4  
 Flags: CY

**RAL** (Rotate left through carry)

$(A_{n+1}) \leftarrow (A_n) ; (CY) \leftarrow (A_7)$   
 $(A_0) \leftarrow (CY)$

The content of the accumulator is rotated left one position through the CY flag. The low order bit is set equal to the CY flag and the CY flag is set to the value shifted out of the high order bit. Only the CY flag is affected.

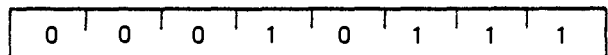

Cycles: 1  
 States: 4  
 Flags: CY

**RAR** (Rotate right through carry)

$(A_n) \leftarrow (A_{n+1}) ; (CY) \leftarrow (A_0)$   
 $(A_7) \leftarrow (CY)$

The content of the accumulator is rotated right one position through the CY flag. The high order bit is set to the CY flag and the CY flag is set to the value shifted out of the low order bit. Only the CY flag is affected.

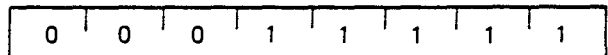

Cycles: 1  
 States: 4  
 Flags: CY

**CMA** (Complement accumulator)

$(A) \leftarrow (\bar{A})$

The contents of the accumulator are complemented (zero bits become 1, one bits become 0). No flags are affected.

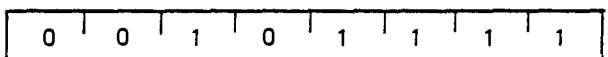

Cycles: 1  
 States: 4  
 Flags: none

**CMC** (Complement carry)

$(CY) \leftarrow (\overline{CY})$

The CY flag is complemented. No other flags are affected.



Cycles: 1  
States: 4  
Flags: CY

Address is specified in byte 3 and byte 2 of the current instruction.

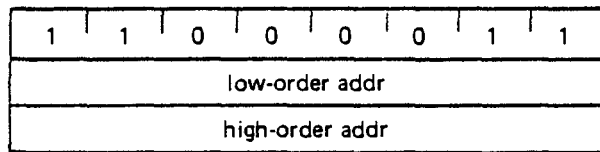

Cycles: 3  
States: 10  
Addressing: immediate  
Flags: none

**STC** (Set carry)

$(CY) \leftarrow 1$

The CY flag is set to 1. No other flags are affected.



Cycles: 1  
States: 4  
Flags: CY

**Jcondition addr** (Conditional jump)

If (CCC),

$(PC) \leftarrow (\text{byte 3}) (\text{byte 2})$

If the specified condition is true, control is transferred to the instruction whose address is specified in byte 3 and byte 2 of the current instruction; otherwise, control continues sequentially.

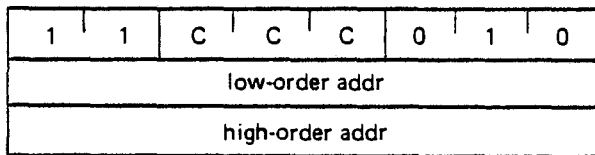

Cycles: 3  
States: 10  
Addressing: immediate  
Flags: none

**Branch Group:**

This group of instructions alter normal sequential program flow.

Condition flags are not affected by any instruction in this group.

The two types of branch instructions are unconditional and conditional. Unconditional transfers simply perform the specified operation on register PC (the program counter). Conditional transfers examine the status of one of the four processor flags to determine if the specified branch is to be executed. The conditions that may be specified are as follows:

| CONDITION                | CCC |
|--------------------------|-----|
| NZ - not zero (Z = 0)    | 000 |
| Z - zero (Z = 1)         | 001 |
| NC - no carry (CY = 0)   | 010 |
| C - carry (CY = 1)       | 011 |
| PO - parity odd (P = 0)  | 100 |
| PE - parity even (P = 1) | 101 |
| P - plus (S = 0)         | 110 |
| M - minus (S = 1)        | 111 |

**CALL addr** (Call)

$((SP) - 1) \leftarrow (PCH)$

$((SP) - 2) \leftarrow (PCL)$

$(SP) \leftarrow (SP) - 2$

$(PC) \leftarrow (\text{byte 3}) (\text{byte 2})$

The high-order eight bits of the next instruction address are moved to the memory location whose address is one less than the content of register SP. The low-order eight bits of the next instruction address are moved to the memory location whose address is two less than the content of register SP. The content of register SP is decremented by 2. Control is transferred to the instruction whose address is specified in byte 3 and byte 2 of the current instruction.

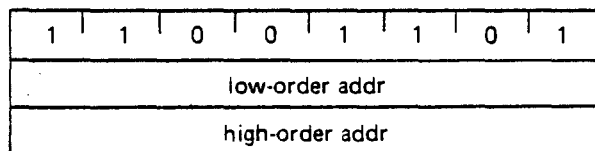

Cycles: 5  
States: 17  
Addressing: immediate/reg. indirect  
Flags: none

**JMP addr** (Jump)

$(PC) \leftarrow (\text{byte 3}) (\text{byte 2})$

Control is transferred to the instruction whose ad-

**Ccondition addr** (Condition call)

If (CCC),  
 $((SP) - 1) \leftarrow (PCH)$   
 $((SP) - 2) \leftarrow (PCL)$   
 $(SP) \leftarrow (SP) - 2$   
 $(PC) \leftarrow (\text{byte 3}) (\text{byte 2})$

If the specified condition is true, the actions specified in the CALL instruction (see above) are performed; otherwise, control continues sequentially.

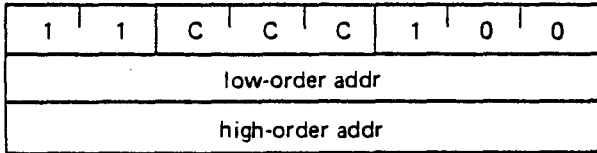

Cycles: 3/5  
 States: 11/17  
 Addressing: immediate/reg. indirect  
 Flags: none

**RET** (Return)

$(PCL) \leftarrow ((SP));$   
 $(PCH) \leftarrow ((SP) + 1);$   
 $(SP) \leftarrow (SP) + 2;$

The content of the memory location whose address is specified in register SP is moved to the low-order eight bits of register PC. The content of the memory location whose address is one more than the content of register SP is moved to the high-order eight bits of register PC. The content of register SP is incremented by 2.



Cycles: 3  
 States: 10  
 Addressing: reg. indirect  
 Flags: none

**Rcondition** (Conditional return)

If (CCC),  
 $(PCL) \leftarrow ((SP)$   
 $(PCH) \leftarrow ((SP) + 1)$   
 $(SP) \leftarrow (SP) + 2$

If the specified condition is true, the actions specified in the RET instruction (see above) are performed; otherwise, control continues sequentially.

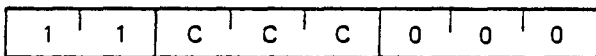

Cycles: 1/3  
 States: 5/11  
 Addressing: reg. indirect  
 Flags: none

**RST n** (Restart)

$((SP) - 1) \leftarrow (PCH)$   
 $((SP) - 2) \leftarrow (PCL)$   
 $(SP) \leftarrow (SP) - 2$   
 $(PC) \leftarrow 8 * (NNN)$

The high-order eight bits of the next instruction address are moved to the memory location whose address is one less than the content of register SP. The low-order eight bits of the next instruction address are moved to the memory location whose address is two less than the content of register SP. The content of register SP is decremented by two. Control is transferred to the instruction whose address is eight times the content of NNN.

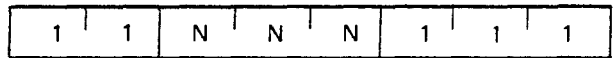

Cycles: 3  
 States: 11  
 Addressing: reg. indirect  
 Flags: none

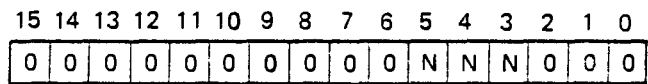

Program Counter After Restart

**PCHL** (Jump H and L indirect — move H and L to PC)

$(PCH) \leftarrow (H)$   
 $(PCL) \leftarrow (L)$

The content of register H is moved to the high-order eight bits of register PC. The content of register L is moved to the low-order eight bits of register PC.

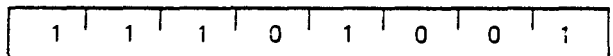

Cycles: 1  
 States: 5  
 Addressing: register  
 Flags: none

## Stack, I/O, and Machine Control Group:

This group of instructions performs I/O, manipulates the Stack, and alters internal control flags.

Unless otherwise specified, condition flags are not affected by any instructions in this group.

### PUSH rp (Push)

$((SP) - 1) \leftarrow (rh)$   
 $((SP) - 2) \leftarrow (rl)$   
 $(SP) \leftarrow (SP) - 2$

The content of the high-order register of register pair *rp* is moved to the memory location whose address is one less than the content of register *SP*. The content of the low-order register of register pair *rp* is moved to the memory location whose address is two less than the content of register *SP*. The content of register *SP* is decremented by 2. **Note: Register pair *rp* = *SP* may not be specified.**

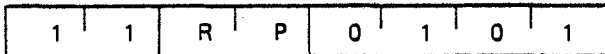

Cycles: 3  
 States: 11  
 Addressing: reg. indirect  
 Flags: none

### PUSH PSW (Push processor status word)

$((SP) - 1) \leftarrow (A)$   
 $((SP) - 2)_0 \leftarrow (CY), ((SP) - 2)_1 \leftarrow 1$   
 $((SP) - 2)_2 \leftarrow (P), ((SP) - 2)_3 \leftarrow 0$   
 $((SP) - 2)_4 \leftarrow (AC), ((SP) - 2)_5 \leftarrow 0$   
 $((SP) - 2)_6 \leftarrow (Z), ((SP) - 2)_7 \leftarrow (S)$   
 $(SP) \leftarrow (SP) - 2$

The content of register *A* is moved to the memory location whose address is one less than register *SP*. The contents of the condition flags are assembled into a processor status word and the word is moved to the memory location whose address is two less than the content of register *SP*. The content of register *SP* is decremented by two.

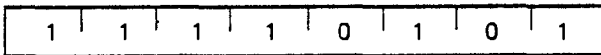

Cycles: 3  
 States: 11  
 Addressing: reg. indirect  
 Flags: none

## FLAG WORD

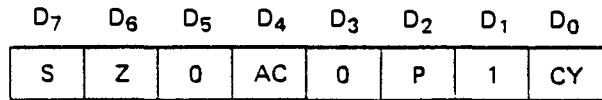

### POP rp (Pop)

$(rl) \leftarrow ((SP))$   
 $(rh) \leftarrow ((SP) + 1)$   
 $(SP) \leftarrow (SP) + 2$

The content of the memory location, whose address is specified by the content of register *SP*, is moved to the low-order register of register pair *rp*. The content of the memory location, whose address is one more than the content of register *SP*, is moved to the high-order register of register pair *rp*. The content of register *SP* is incremented by 2. **Note: Register pair *rp* = *SP* may not be specified.**



Cycles: 3  
 States: 10  
 Addressing: reg. indirect  
 Flags: none

### POP PSW (Pop processor status word)

$(CY) \leftarrow ((SP))_0$   
 $(P) \leftarrow ((SP))_2$   
 $(AC) \leftarrow ((SP))_4$   
 $(Z) \leftarrow ((SP))_6$   
 $(S) \leftarrow ((SP))_7$   
 $(A) \leftarrow ((SP) + 1)$   
 $(SP) \leftarrow (SP) + 2$

The content of the memory location whose address is specified by the content of register *SP* is used to restore the condition flags. The content of the memory location whose address is one more than the content of register *SP* is moved to register *A*. The content of register *SP* is incremented by 2.

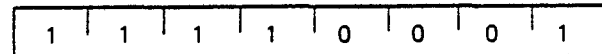

Cycles: 3  
 States: 10  
 Addressing: reg. indirect  
 Flags: Z,S,P,CY,AC

**XTHL** (Exchange stack top with H and L)

(L)  $\leftrightarrow$  ((SP))

(H)  $\leftrightarrow$  ((SP) + 1)

The content of the L register is exchanged with the content of the memory location whose address is specified by the content of register SP. The content of the H register is exchanged with the content of the memory location whose address is one more than the content of register SP.



Cycles: 5  
States: 18  
Addressing: reg. indirect  
Flags: none

**SPHL** (Move HL to SP)

(SP)  $\leftarrow$  (H) (L)

The contents of registers H and L (16 bits) are moved to register SP.



Cycles: 1  
States: 5  
Addressing: register  
Flags: none

**IN port** (Input)

(A)  $\leftarrow$  (data)

The data placed on the eight bit bi-directional data bus by the specified port is moved to register A.

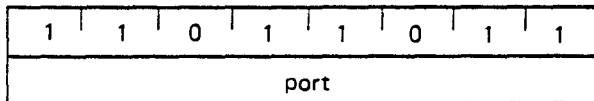

Cycles: 3  
States: 10  
Addressing: direct  
Flags: none

**OUT port** (Output)

(data)  $\leftarrow$  (A)

The content of register A is placed on the eight bit bi-directional data bus for transmission to the specified port.

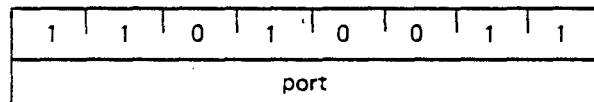

Cycles: 3  
States: 10  
Addressing: direct  
Flags: none

**EI** (Enable interrupts)

The interrupt system is enabled following the execution of the next instruction.



Cycles: 1  
States: 4  
Flags: none

**DI** (Disable interrupts)

The interrupt system is disabled immediately following the execution of the DI instruction.



Cycles: 1  
States: 4  
Flags: none

**HLT** (Halt)

The processor is stopped. The registers and flags are unaffected.

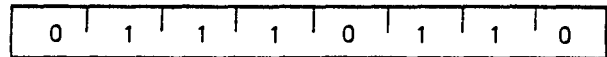

Cycles: 1  
States: 7  
Flags: none

**NOP** (No op)

No operation is performed. The registers and flags are unaffected.

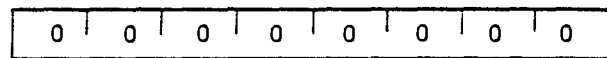

Cycles: 1  
States: 4  
Flags: none



ALTAIR 8800b  
SECTION III  
THEORY OF OPERATION



### 3-1. GENERAL

This section contains information needed to understand the operation of the MITS Altair 8800b computer (8800b). It contains a basic description of the logic symbols used in the 8800b schematics and detailed theory of the 8800b Central Processing Unit, Interface and Front Panel circuits.

### 3-2. LOGIC CIRCUITS

The logic circuits used in the 8800b drawings are presented as a tabular listing in Table 3-1. The table is constructed to present the functional name, symbolic representation, and a brief description of each logic circuit. Where applicable, a truth table is provided to aid in understanding circuit operation. Although Table 3-1 does not include every logic circuit used in the drawings, all unmentioned circuits (and their symbolic representations) are variations of the circuits presented with their functional descriptions basically the same. The active state of the inputs and outputs of the logic circuits is graphically displayed by small circles. A small circle, at an input to a logic circuit, indicates that the input is an active LOW; that is, a LOW signal will enable the input. A small circle, at the output of a logic circuit, indicates that the output is an active LOW; that is, the output is low in the actuated state. Conversely, the absence of a small circle indicates that the input or output is active HIGH.

Table 3-1. Symbol Definitions



| NAME                     | LOGIC SYMBOL  | DESCRIPTION  |
|--------------------------|---|--|
| NAND gate                |  $Y = \overline{AB \dots N}$     | <p>The NAND gate performs one of the fundamental logic functions.</p> <p>All of the inputs have to be enabled (HIGH) to produce the desired (LOW) output. The output is HIGH if any of the inputs are LOW.</p> |
| NOR gate                 |  $Y = \overline{A + B \dots +N}$ | <p>The NOR gate performs one of the fundamental logic functions.</p> <p>Any of the inputs need to be enabled (HIGH) to produce the desired (LOW) output. The output is HIGH if all of the inputs are LOW.</p>  |
| Inverter                 |                                | <p>The inverter is a device whose output is the opposite state of the input.</p>   |
| Non-Inverting Bus Driver |                                | <p>The non-inverting bus driver is a device whose output is the same state as the input. Data is enabled through the device by applying a (LOW) signal to the E input.</p>                                     |
| Inverting Bus Driver     |                                | <p>The inverting bus driver is a device whose output is the opposite state of the input. Data is enabled through the driver by applying a (LOW) signal to the E input.</p>                                     |

Table 3-1. Symbol Definitions - Continued

| NAME                            | LOGIC SYMBOL   | DESCRIPTION   |           |  |   |   |           |   |   |   |   |   |   |  |
|---------------------------------|--|---|-----------|--|---|---|-----------|---|---|---|---|---|---|--|
| Edge triggered D type flip-flop |  <p style="text-align: center;"><b>Truth Table</b></p> <table border="1" data-bbox="506 848 734 1052"> <thead> <tr> <th><math>T_n</math></th> <th colspan="2"><math>T_{n+1}</math></th> </tr> <tr> <th>D</th> <th>Q</th> <th><math>\bar{Q}</math></th> </tr> </thead> <tbody> <tr> <td>L</td> <td>L</td> <td>H</td> </tr> <tr> <td>H</td> <td>H</td> <td>L</td> </tr> </tbody> </table> | $T_n$   | $T_{n+1}$ |  | D | Q | $\bar{Q}$ | L | L | H | H | H | L | <p>Applying a LOW signal to the preset input (P) sets the flip-flop with output Q HIGH and output <math>\bar{Q}</math> LOW. Applying a LOW signal to the clear input (C) resets the flip-flop with Q LOW and <math>\bar{Q}</math> HIGH. This method of setting and resetting the flip-flop is independent of the clock (asynchronous). If a signal is applied to the D input, the flip-flop Q output is directly affected on the positive edge of the clock (truth table).</p> |
| $T_n$                           | $T_{n+1}$  |   |           |  |   |   |           |   |   |   |   |   |   |  |
| D                               | Q  | $\bar{Q}$   |           |  |   |   |           |   |   |   |   |   |   |  |
| L                               | L  | H   |           |  |   |   |           |   |   |   |   |   |   |  |
| H                               | H  | L   |           |  |   |   |           |   |   |   |   |   |   |  |
| QUAD D flip-flop                |   | <p>The information on the D inputs is stored during the positive edge of the clock (CK). The clear (C) input, when LOW, resets all flip-flops independent of the clock or D inputs.</p>   |           |  |   |   |           |   |   |   |   |   |   |  |
| 4-Bit Binary Ripple Counter     |   | <p>The 4-bit binary ripple counter operation requires that the QA output be externally connected to input <math>CP_B</math>. The input count pulses (negative edge) are applied to input <math>CP_A</math> enabling a divide by 2, 4, 8, and 16 at the QA, QB, QC, and QD outputs. The reset (RO) input resets the counter regardless of the clock input (<math>CP_A</math>) when both inputs are HIGH.</p> |           |  |   |   |           |   |   |   |   |   |   |  |

Table 3-1. Symbol Definitions - Continued

| NAME                  | LOGIC SYMBOL | DESCRIPTION   |
|-----------------------|--------------|---|
| 12-Bit Binary Counter |              | <p>The 12-bit counter is triggered on the negative edge of the clock input (CP). A HIGH on the master reset input (MR) clears all counter stages and forces all outputs (Q0-Q11) LOW which is independent of the clock input.</p>   |
| Bi-Directional Device |              | <p>Output data from a device is present on the <math>DI_0</math>-<math>DI_3</math> lines and is enabled when <math>\overline{DIEN}</math> and <math>\overline{CS}</math> are LOW. Lines <math>DB_0</math>-<math>DB_3</math> transfer the data to the receiving unit. Input data to the device is present on the <math>DB_0</math>-<math>DB_3</math> lines and is enabled when <math>\overline{DIEN}</math> is HIGH and <math>\overline{CS}</math> is LOW. Input data is transferred to the device on the <math>DO_0</math>-<math>DO_3</math> lines.</p> |
| Clock Generator       |              | <p>The XTAL 1 and 2 inputs allow for an external crystal connection which produces a <math>\phi 1</math> and <math>\phi 2</math> master clock for the 8800b. The SYNC input from the 8080 (CPU) and internal timing generate a LOW status strobe (<math>\overline{STSTB}</math>) signal. The reset in (<math>\overline{RESIN}</math>) input generates a RESET output to condition the 8080 (CPU). A HIGH ready in (RDYIN) input generates a READY output to enable the CPU.</p>   |

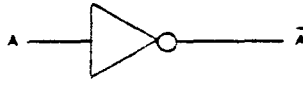
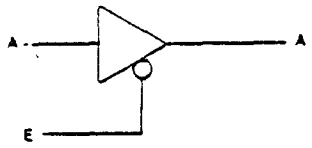
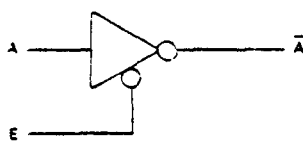
Table 3-1. Symbol Definitions - Continued

| NAME       | LOGIC SYMBOL  | DESCRIPTION  |
|------------|---|--|
| Data Latch |  | <p>The data latch is used to store or transfer data on the <math>DO_0</math>-<math>DO_7</math> outputs by affecting the data latch control inputs. There are several different ways used to store data or transfer it to the data latch.</p> <p>When data is presented to the <math>DI_0</math>-<math>DI_7</math> inputs and the device selection 2 (DS2), mode MD, and strobe (STB) are HIGH, a LOW device selection 1 (<math>\overline{DS1}</math>) allows the input data to be present on the <math>DO_0</math>-<math>DO_7</math> outputs.</p> <p>When data is presented to the <math>DI_0</math>-<math>DI_7</math> inputs and MD and STB are HIGH, a HIGH DS2 and LOW <math>\overline{DS1}</math> allow the input data to be present on the <math>DO_0</math>-<math>DO_7</math> outputs.</p> <p>When data is presented to the <math>DI_0</math>-<math>DI_7</math> inputs and <math>\overline{DS1}</math> and MD are LOW, a HIGH DS2 and STB allow the input data to be present on the <math>DO_0</math>-<math>DO_7</math> outputs.</p> <p>When data is presented to the <math>DI_0</math>-<math>DI_7</math> inputs, and MD and DS2 are HIGH with <math>\overline{DS1}</math> LOW, the input data is directly transferred to the <math>DO_0</math>-<math>DO_7</math> outputs as long as these states are present.</p> |

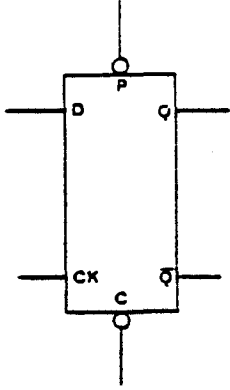
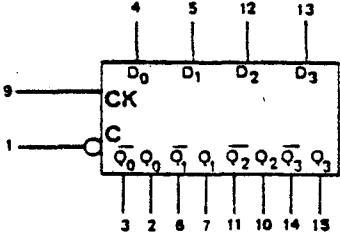
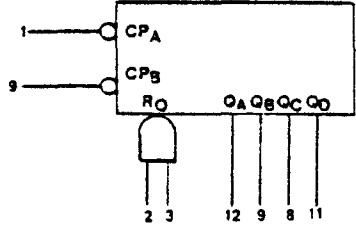
Table 3-1. Symbol Definitions - Continued

| NAME                                 | LOGIC SYMBOL   | DESCRIPTION   |
|--------------------------------------|--|---|
| PROM (programmable read only memory) |  <p>The logic symbol for PROM is a rectangle with eight address lines on the left side, labeled A<sub>0</sub> through A<sub>7</sub>, and one chip select line labeled CS. The address lines are connected to pins 2, 1, 3, 21, 20, 19, 18, and 17 respectively. The CS line is connected to pin 14. On the bottom side, there are eight data lines labeled D<sub>0</sub> through D<sub>7</sub>, which are connected to pins 4, 5, 6, 7, 8, 9, 10, and 11 respectively.</p> | <p>When the chip select input (CS) is LOW, the binary address at input A<sub>0</sub> through A<sub>7</sub> is decoded to select one of 256 address locations. The data is present on the D<sub>0</sub> through D<sub>8</sub> outputs.</p> |

3-3. INTEL 8080 MICROCOMPUTER SYSTEMS USER'S INFORMATION

Pages 3-9 through 3-38 are excerpts from the Intel 8080 Micro-computer Systems User's Manual, reprinted by permission of Intel Corporation, Copyright, 1975. Included is information on the 8080A Microprocessor, the 8212 Input/Output Port, the 8216 Bi-Directional Bus Driver, and the 8224 Clock Generator and Driver. It is recommended that a good understanding of these integrated circuit operations be developed before continuing this section.

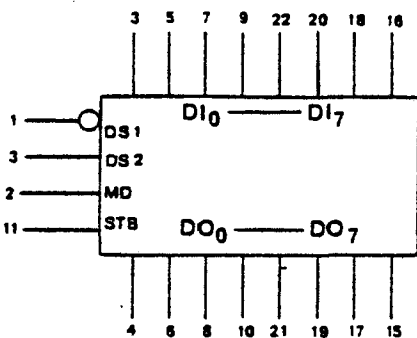
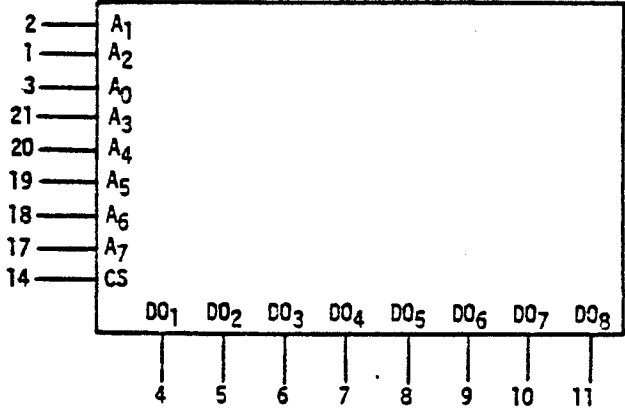

# Silicon Gate MOS 8080A

## SINGLE CHIP 8-BIT N-CANNEL MICROPROCESSOR

The 8080A is functionally and electrically compatible with the Intel® 8080.

- TTL Drive Capability
- 2  $\mu$ s Instruction Cycle
- Powerful Problem Solving Instruction Set
- Six General Purpose Registers and an Accumulator
- Sixteen Bit Program Counter for Directly Addressing up to 64K Bytes of Memory
- Sixteen Bit Stack Pointer and Stack Manipulation Instructions for Rapid Switching of the Program Environment
- Decimal, Binary and Double Precision Arithmetic
- Ability to Provide Priority Vectored Interrupts
- 512 Directly Addressed I/O Ports

The Intel® 8080A is a complete 8-bit parallel central processing unit (CPU). It is fabricated on a single LSI chip using Intel's n-channel silicon gate MOS process. This offers the user a high performance solution to control and processing applications. The 8080A contains six 8-bit general purpose working registers and an accumulator. The six general purpose registers may be addressed individually or in pairs providing both single and double precision operators. Arithmetic and logical instructions set or reset four testable flags. A fifth flag provides decimal arithmetic operation.

The 8080A has an external stack feature wherein any portion of memory may be used as a last in/first out stack to store/retrieve the contents of the accumulator, flags, program counter and all of the six general purpose registers. The sixteen bit stack pointer controls the addressing of this external stack. This stack gives the 8080A the ability to easily handle multiple level priority interrupts by rapidly storing and restoring processor status. It also provides almost unlimited subroutine nesting. This microprocessor has been designed to simplify systems design. Separate 16-line address and 8-line bi-directional data busses are used to facilitate easy interface to memory and I/O. Signals to control the interface to memory and I/O are provided directly by the 8080A. Ultimate control of the address and data busses resides with the HOLD signal. It provides the ability to suspend processor operation and force the address and data busses into a high impedance state. This permits OR-tying these busses with other controlling devices for (DMA) direct memory access or multi-processor operation.

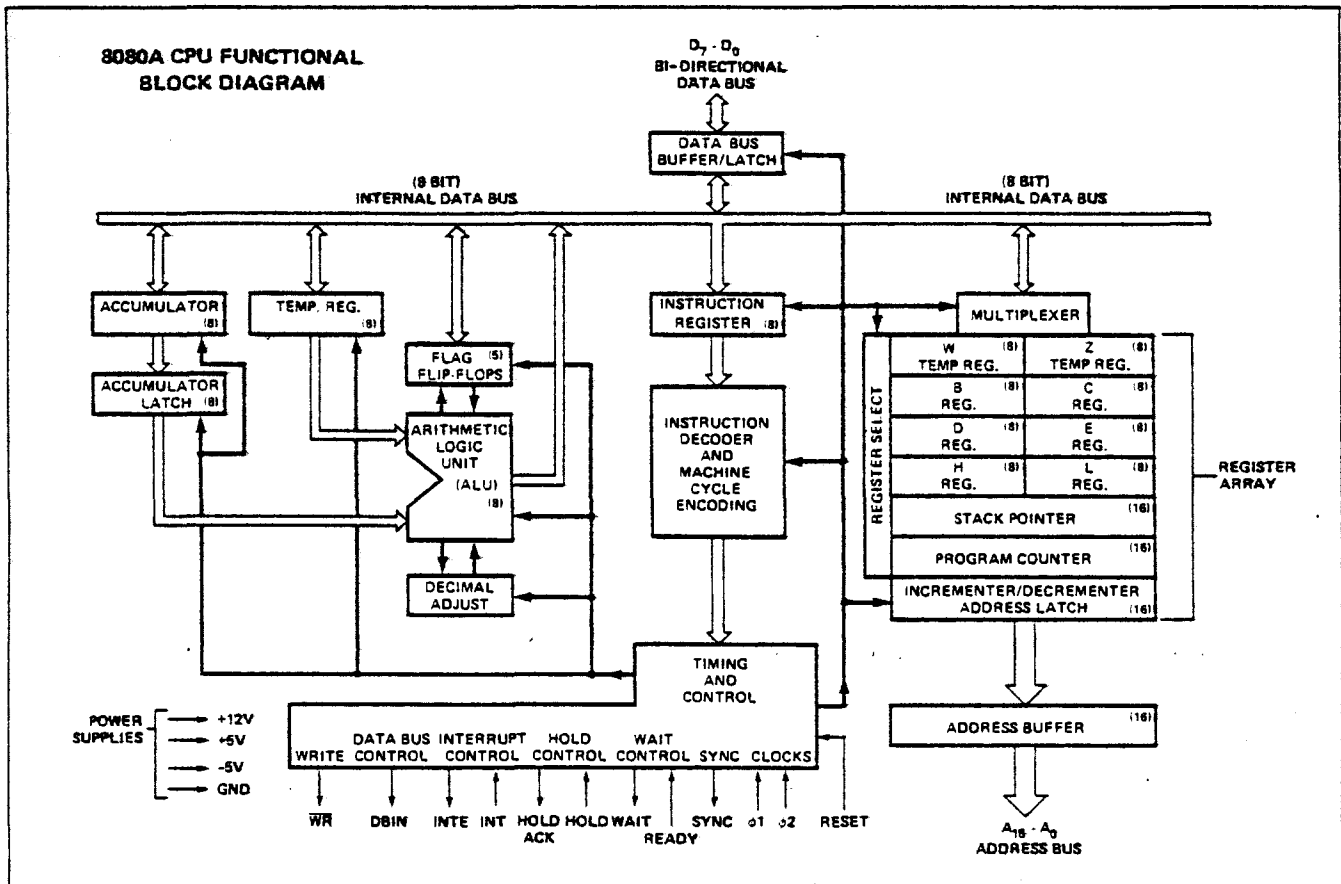

# SILICON GATE MOS 8080A

## 8080A FUNCTIONAL PIN DEFINITION

The following describes the function of all of the 8080A I/O pins. Several of the descriptions refer to internal timing periods.

### A<sub>15</sub>-A<sub>0</sub> (output three-state)

**ADDRESS BUS;** the address bus provides the address to memory (up to 64K 8-bit words) or denotes the I/O device number for up to 256 input and 256 output devices. A<sub>0</sub> is the least significant address bit.

### D<sub>7</sub>-D<sub>0</sub> (input/output three-state)

**DATA BUS;** the data bus provides bi-directional communication between the CPU, memory, and I/O devices for instructions and data transfers. Also, during the first clock cycle of each machine cycle, the 8080A outputs a status word on the data bus that describes the current machine cycle. D<sub>0</sub> is the least significant bit.

### SYNC (output)

**SYNCHRONIZING SIGNAL;** the SYNC pin provides a signal to indicate the beginning of each machine cycle.

### DBIN (output)

**DATA BUS IN;** the DBIN signal indicates to external circuits that the data bus is in the input mode. This signal should be used to enable the gating of data onto the 8080A data bus from memory or I/O.

### READY (input)

**READY;** the READY signal indicates to the 8080A that valid memory or input data is available on the 8080A data bus. This signal is used to synchronize the CPU with slower memory or I/O devices. If after sending an address out the 8080A does not receive a READY input, the 8080A will enter a WAIT state for as long as the READY line is low. READY can also be used to single step the CPU.

### WAIT (output)

**WAIT;** the WAIT signal acknowledges that the CPU is in a WAIT state.

### $\overline{WR}$ (output)

**WRITE;** the  $\overline{WR}$  signal is used for memory WRITE or I/O output control. The data on the data bus is stable while the  $\overline{WR}$  signal is active low ( $\overline{WR} = 0$ ).

### HOLD (input)

**HOLD;** the HOLD signal requests the CPU to enter the HOLD state. The HOLD state allows an external device to gain control of the 8080A address and data bus as soon as the 8080A has completed its use of these buses for the current machine cycle. It is recognized under the following conditions:

- the CPU is in the HALT state.
  - the CPU is in the T<sub>2</sub> or T<sub>W</sub> state and the READY signal is active.
- As a result of entering the HOLD state the CPU ADDRESS BUS (A<sub>15</sub>-A<sub>0</sub>) and DATA BUS (D<sub>7</sub>-D<sub>0</sub>) will be in their high impedance state. The CPU acknowledges its state with the HOLD ACKNOWLEDGE (HLDA) pin.

### HLDA (output)

**HOLD ACKNOWLEDGE;** the HLDA signal appears in response to the HOLD signal and indicates that the data and address bus

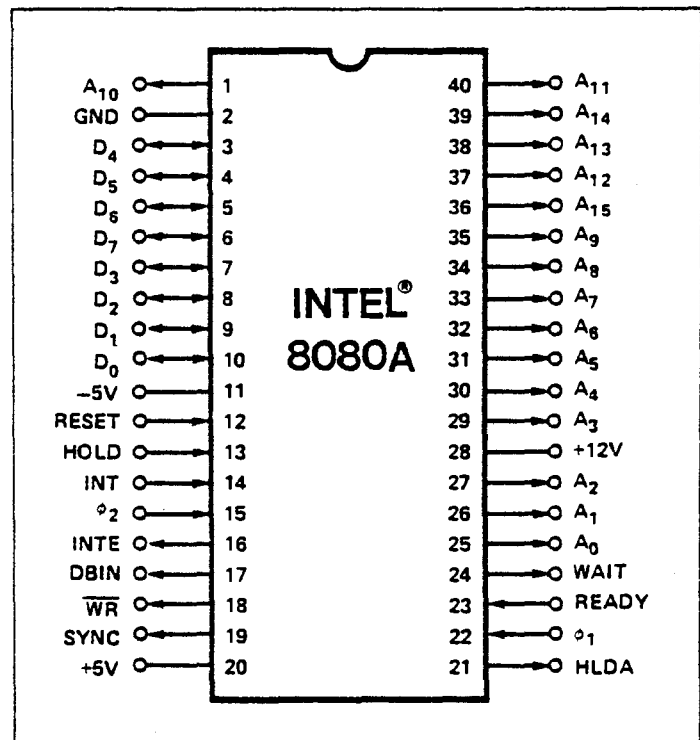

Pin Configuration

will go to the high impedance state. The HLDA signal begins at:

- T<sub>3</sub> for READ memory or input.
- The Clock Period following T<sub>3</sub> for WRITE memory or OUTPUT operation.

In either case, the HLDA signal appears after the rising edge of  $\phi_1$  and high impedance occurs after the rising edge of  $\phi_2$ .

### INTE (output)

**INTERRUPT ENABLE;** indicates the content of the internal interrupt enable flip/flop. This flip/flop may be set or reset by the Enable and Disable Interrupt instructions and inhibits interrupts from being accepted by the CPU when it is reset. It is automatically reset (disabling further interrupts) at time T<sub>1</sub> of the instruction fetch cycle (M1) when an interrupt is accepted and is also reset by the RESET signal.

### INT (input)

**INTERRUPT REQUEST;** the CPU recognizes an interrupt request on this line at the end of the current instruction or while halted. If the CPU is in the HOLD state or if the Interrupt Enable flip/flop is reset it will not honor the request.

### RESET (input)[1]

**RESET;** while the RESET signal is activated, the content of the program counter is cleared. After RESET, the program will start at location 0 in memory. The INTE and HLDA flip/flops are also reset. Note that the flags, accumulator, stack pointer, and registers are not cleared.

- V<sub>SS</sub> Ground Reference.
- V<sub>DD</sub> +12 ± 5% Volts.
- V<sub>CC</sub> +5 ± 5% Volts.
- V<sub>BB</sub> -5 ± 5% Volts (substrate bias).
- $\phi_1, \phi_2$  2 externally supplied clock phases. (non TTL compatible)



# SILICON GATE MOS 8080A

## ABSOLUTE MAXIMUM RATINGS\*

|   |                 |
|---|-----------------|
| Temperature Under Bias                                    | 0°C to +70°C    |
| Storage Temperature                                       | -65°C to +150°C |
| All Input or Output Voltages                              |                 |
| With Respect to $V_{BB}$                                  | -0.3V to +20V   |
| $V_{CC}$ , $V_{DD}$ and $V_{SS}$ With Respect to $V_{BB}$ | -0.3V to +20V   |
| Power Dissipation   | 1.5W            |

\*COMMENT: Stresses above those listed under "Absolute Maximum Ratings" may cause permanent damage to the device. This is a stress rating only and functional operation of the device at these or any other conditions above those indicated in the operational sections of this specification is not implied. Exposure to absolute maximum rating conditions for extended periods may affect device reliability.

## D.C. CHARACTERISTICS

$T_A = 0^\circ\text{C}$  to  $70^\circ\text{C}$ ,  $V_{DD} = +12\text{V} \pm 5\%$ ,  $V_{CC} = +5\text{V} \pm 5\%$ ,  $V_{BB} = -5\text{V} \pm 5\%$ ,  $V_{SS} = 0\text{V}$ , Unless Otherwise Noted.

| Symbol       | Parameter                                | Min.       | Typ. | Max.         | Unit                | Test Condition   |
|--------------|--|------------|------|--------------|---------------------|--|
| $V_{ILC}$    | Clock Input Low Voltage                  | $V_{SS}-1$ |      | $V_{SS}+0.8$ | V                   | $I_{OL} = 1.9\text{mA}$ on all outputs,<br>$I_{OH} = -150\mu\text{A}$ .<br><br>Operation<br>$T_{CY} = .48\mu\text{sec}$  |
| $V_{IHC}$    | Clock Input High Voltage                 | 9.0        |      | $V_{DD}+1$   | V                   |  |
| $V_{IL}$     | Input Low Voltage                        | $V_{SS}-1$ |      | $V_{SS}+0.8$ | V                   |  |
| $V_{IH}$     | Input High Voltage                       | 3.3        |      | $V_{CC}+1$   | V                   |  |
| $V_{OL}$     | Output Low Voltage                       |            |      | 0.45         | V                   |  |
| $V_{OH}$     | Output High Voltage                      | 3.7        |      |              | V                   |  |
| $I_{DD(AV)}$ | Avg. Power Supply Current ( $V_{DD}$ )   |            | 40   | 70           | mA                  | $V_{SS} \leq V_{IN} \leq V_{CC}$<br>$V_{SS} \leq V_{CLOCK} \leq V_{DD}$<br>$V_{SS} \leq V_{IN} \leq V_{SS} + 0.8\text{V}$<br>$V_{SS} + 0.8\text{V} \leq V_{IN} \leq V_{CC}$<br><br>$V_{ADDR/DATA} = V_{CC}$<br>$V_{ADDR/DATA} = V_{SS} + 0.45\text{V}$ |
| $I_{CC(AV)}$ | Avg. Power Supply Current ( $V_{CC}$ )   |            | 60   | 80           | mA                  |  |
| $I_{BB(AV)}$ | Avg. Power Supply Current ( $V_{BB}$ )   |            | .01  | 1            | mA                  |  |
| $I_{IL}$     | Input Leakage                            |            |      | $\pm 10$     | $\mu\text{A}$       |  |
| $I_{CL}$     | Clock Leakage                            |            |      | $\pm 10$     | $\mu\text{A}$       |  |
| $I_{DL} [2]$ | Data Bus Leakage in Input Mode           |            |      | -100<br>-2.0 | $\mu\text{A}$<br>mA |  |
| $I_{FL}$     | Address and Data Bus Leakage During HOLD |            |      | +10<br>-100  | $\mu\text{A}$       |  |

## CAPACITANCE

$T_A = 25^\circ\text{C}$   $V_{CC} = V_{DD} = V_{SS} = 0\text{V}$ ,  $V_{BB} = -5\text{V}$

| Symbol    | Parameter          | Typ. | Max. | Unit | Test Condition       |
|-----------|--------------------|------|------|------|----------------------|
| $C_\phi$  | Clock Capacitance  | 17   | 25   | pf   | $f_c = 1\text{MHz}$  |
| $C_{IN}$  | Input Capacitance  | 6    | 10   | pf   | Unmeasured Pins      |
| $C_{OUT}$ | Output Capacitance | 10   | 20   | pf   | Returned to $V_{SS}$ |

### NOTES:

- The RESET signal must be active for a minimum of 3 clock cycles.
- When DBIN is high and  $V_{IN} > V_{IH}$  an internal active pull up will be switched onto the Data Bus.
- $\Delta I_{supply} / \Delta T_A = -0.45\%/^\circ\text{C}$ .

TYPICAL SUPPLY CURRENT VS. TEMPERATURE, NORMALIZED. [3]

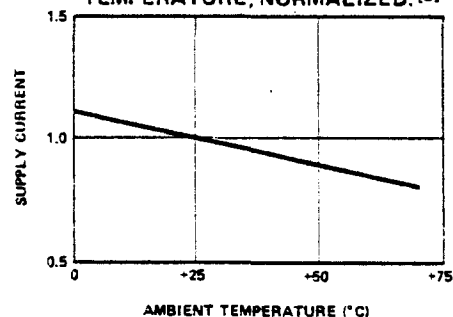

DATA BUS CHARACTERISTIC DURING DBIN

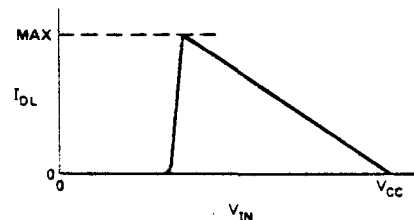

# SILICON GATE MOS 8080A

## A.C. CHARACTERISTICS

$T_A = 0^\circ\text{C}$  to  $70^\circ\text{C}$ ,  $V_{DD} = +12\text{V} \pm 5\%$ ,  $V_{CC} = +5\text{V} \pm 5\%$ ,  $V_{BB} = -5\text{V} \pm 5\%$ ,  $V_{SS} = 0\text{V}$ , Unless Otherwise Noted

| Symbol         | Parameter  | Min. | Max.     | Unit            | Test Condition       |
|----------------|--|------|----------|-----------------|----------------------|
| $t_{CY}^{[3]}$ | Clock Period   | 0.48 | 2.0      | $\mu\text{sec}$ |                      |
| $t_r, t_f$     | Clock Rise and Fall Time   | 0    | 50       | n sec           |                      |
| $t_{\phi 1}$   | $\phi_1$ Pulse Width   | 60   |          | n sec           |                      |
| $t_{\phi 2}$   | $\phi_2$ Pulse Width   | 220  |          | n sec           |                      |
| $t_{D1}$       | Delay $\phi_1$ to $\phi_2$   | 0    |          | n sec           |                      |
| $t_{D2}$       | Delay $\phi_2$ to $\phi_1$   | 70   |          | n sec           |                      |
| $t_{D3}$       | Delay $\phi_1$ to $\phi_2$ Leading Edges   | 80   |          | n sec           |                      |
| $t_{DA}^{[2]}$ | Address Output Delay From $\phi_2$   |      | 200      | n sec           | $C_L = 100\text{pf}$ |
| $t_{DD}^{[2]}$ | Data Output Delay From $\phi_2$  |      | 220      | n sec           |                      |
| $t_{DC}^{[2]}$ | Signal Output Delay From $\phi_1$ , or $\phi_2$ (SYNC, $\overline{WR}$ , WAIT, HLDA) |      | 120      | n sec           | $C_L = 50\text{pf}$  |
| $t_{DF}^{[2]}$ | DBIN Delay From $\phi_2$   | 25   | 140      | n sec           |                      |
| $t_{D1}^{[1]}$ | Delay for Input Bus to Enter Input Mode  |      | $t_{DF}$ | n sec           |                      |
| $t_{DS1}$      | Data Setup Time During $\phi_1$ and DBIN   | 30   |          | n sec           |                      |

## TIMING WAVEFORMS <sup>[14]</sup>

(Note: Timing measurements are made at the following reference voltages: CLOCK "1" = 8.0V "0" = 1.0V; INPUTS "1" = 3.3V, "0" = 0.8V; OUTPUTS "1" = 2.0V, "0" = 0.8V.)

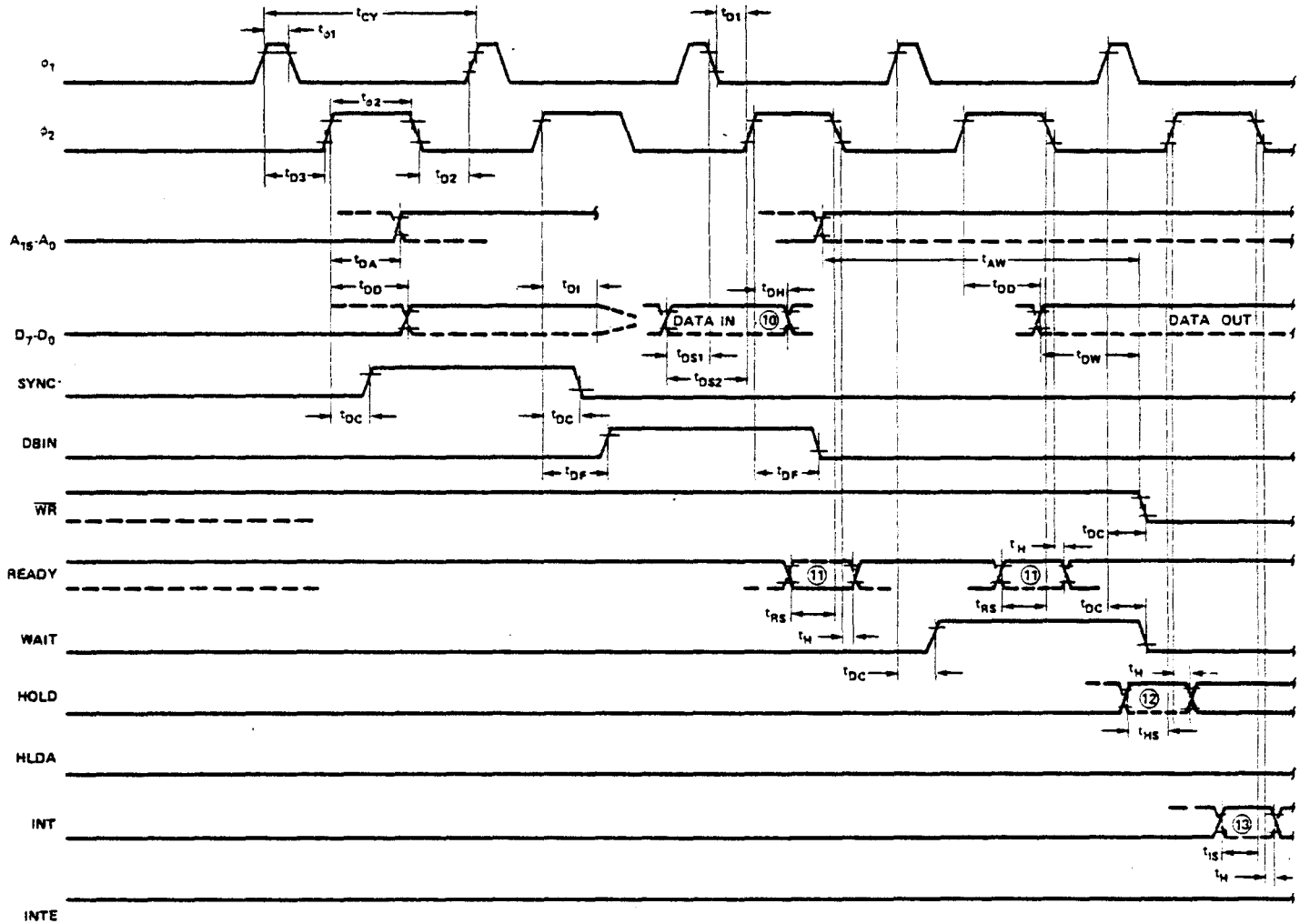

# SILICON GATE MOS 8080A

## A.C. CHARACTERISTICS (Continued)

$T_A = 0^\circ\text{C}$  to  $70^\circ\text{C}$ ,  $V_{DD} = +12\text{V} \pm 5\%$ ,  $V_{CC} = +5\text{V} \pm 5\%$ ,  $V_{BB} = -5\text{V} \pm 5\%$ ,  $V_{SS} = 0\text{V}$ , Unless Otherwise Noted

| Symbol         | Parameter   | Min. | Max. | Unit  | Test Condition  |
|----------------|---|------|------|-------|---|
| $t_{DS2}$      | Data Setup Time to $\phi_2$ During DBIN                       | 150  |      | n sec | $C_L = 50\text{pf}$<br><br>$C_L = 100\text{pf}$ : Address, Data<br>$C_L = 50\text{pf}$ : $\overline{WR}$ , HLDA, DBIN |
| $t_{DH}^{[1]}$ | Data Hold Time From $\phi_2$ During DBIN                      | [1]  |      | n sec |   |
| $t_{IE}^{[2]}$ | INTE Output Delay From $\phi_2$                               |      | 200  | n sec |   |
| $t_{RS}$       | READY Setup Time During $\phi_2$                              | 120  |      | n sec |   |
| $t_{HS}$       | HOLD Setup Time to $\phi_2$                                   | 140  |      | n sec |   |
| $t_{IS}$       | INT Setup Time During $\phi_2$ (During $\phi_1$ in Halt Mode) | 120  |      | n sec |   |
| $t_H$          | Hold Time From $\phi_2$ (READY, INT, HOLD)                    | 0    |      | n sec |   |
| $t_{FD}$       | Delay to Float During Hold (Address and Data Bus)             |      | 120  | n sec |   |
| $t_{AW}^{[2]}$ | Address Stable Prior to $\overline{WR}$                       | [5]  |      | n sec |   |
| $t_{DW}^{[2]}$ | Output Data Stable Prior to $\overline{WR}$                   | [6]  |      | n sec |   |
| $t_{WD}^{[2]}$ | Output Data Stable From $\overline{WR}$                       | [7]  |      | n sec |   |
| $t_{WA}^{[2]}$ | Address Stable From $\overline{WR}$                           | [7]  |      | n sec |   |
| $t_{HF}^{[2]}$ | HLDA to Float Delay   | [8]  |      | n sec |   |
| $t_{WF}^{[2]}$ | $\overline{WR}$ to Float Delay                                | [9]  |      | n sec |   |
| $t_{AH}^{[2]}$ | Address Hold Time After DBIN During HLDA                      | -20  |      | n sec |   |

### NOTES:

- Data input should be enabled with DBIN status. No bus conflict can then occur and data hold time is assured.  $t_{DH} = 50\text{ns}$  or  $t_{DP}$ , whichever is less.
- Load Circuit.

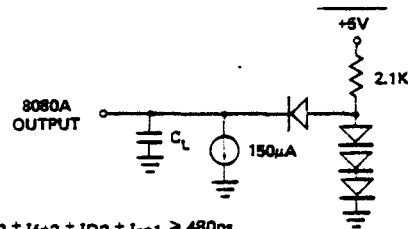
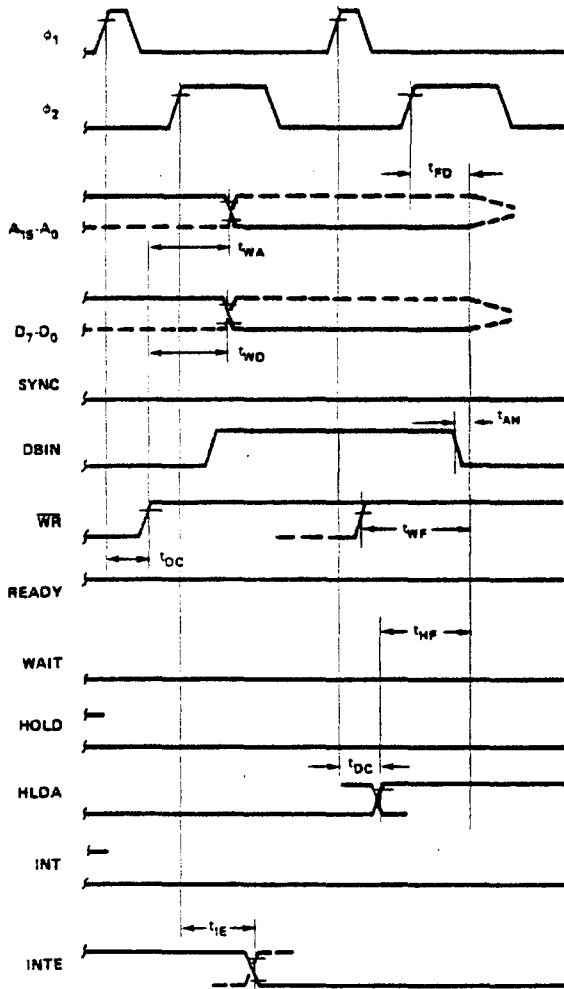

- $t_{CY} = t_{D3} + t_{r\phi 2} + t_{\phi 2} + t_{f\phi 2} + t_{D2} + t_{r\phi 1} > 480\text{ns}$ .

TYPICAL  $\Delta$  OUTPUT DELAY VS.  $\Delta$  CAPACITANCE

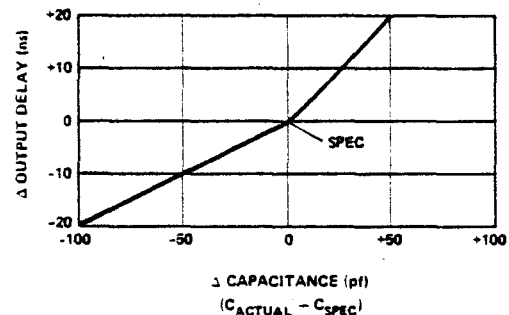

- The following are relevant when interfacing the 8080A to devices having  $V_{IH} = 3.3\text{V}$ :
  - Maximum output rise time from .8V to 3.3V = 100ns @  $C_L = \text{SPEC}$ .
  - Output delay when measured to 3.0V = SPEC + 60ns @  $C_L = \text{SPEC}$ .
  - If  $C_L \neq \text{SPEC}$ , add .6ns/pF if  $C_L > C_{\text{SPEC}}$ , subtract .3ns/pF (from modified delay) if  $C_L < C_{\text{SPEC}}$ .
- $t_{AW} = 2 t_{CY} - t_{D3} - t_{r\phi 2} - 140\text{nsec}$ .
- $t_{DW} = t_{CY} - t_{D3} - t_{r\phi 2} - 170\text{nsec}$ .
- If not HLDA,  $t_{WD} = t_{WA} = t_{D3} + t_{r\phi 2} + 10\text{ns}$ . If HLDA,  $t_{WD} = t_{WA} = t_{WF}$ .
- $t_{HF} = t_{D3} + t_{r\phi 2} - 50\text{ns}$ .
- $t_{WF} = t_{D3} + t_{r\phi 2} - 10\text{ns}$ .
- Data in must be stable for this period during DBIN  $\cdot T_3$ . Both  $t_{DS1}$  and  $t_{DS2}$  must be satisfied.
- Ready signal must be stable for this period during  $T_2$  or  $T_W$ . (Must be externally synchronized.)
- Hold signal must be stable for this period during  $T_2$  or  $T_W$  when entering hold mode, and during  $T_3$ ,  $T_4$ ,  $T_5$  and  $T_{WH}$  when in hold mode. (External synchronization is not required.)
- Interrupt signal must be stable during this period of the last clock cycle of any instruction in order to be recognized on the following instruction. (External synchronization is not required.)
- This timing diagram shows timing relationships only; it does not represent any specific machine cycle.

## INSTRUCTION SET

The accumulator group instructions include arithmetic and logical operators with direct, indirect, and immediate addressing modes.

Move, load, and store instruction groups provide the ability to move either 8 or 16 bits of data between memory, the six working registers and the accumulator using direct, indirect, and immediate addressing modes.

The ability to branch to different portions of the program is provided with jump, jump conditional, and computed jumps. Also the ability to call to and return from sub-routines is provided both conditionally and unconditionally. The RESTART (or single byte call instruction) is useful for interrupt vector operation.

Double precision operators such as stack manipulation and double add instructions extend both the arithmetic and interrupt handling capability of the 8080A. The ability to

increment and decrement memory, the six general registers and the accumulator is provided as well as extended increment and decrement instructions to operate on the register pairs and stack pointer. Further capability is provided by the ability to rotate the accumulator left or right through or around the carry bit.

Input and output may be accomplished using memory addresses as I/O ports or the directly addressed I/O provided for in the 8080A instruction set.

The following special instruction group completes the 8080A instruction set: the NOP instruction, HALT to stop processor execution and the DAA instructions provide decimal arithmetic capability. STC allows the carry flag to be directly set, and the CMC instruction allows it to be complemented. CMA complements the contents of the accumulator and XCHG exchanges the contents of two 16-bit register pairs directly.

### Data and Instruction Formats

Data in the 8080A is stored in the form of 8-bit binary integers. All data transfers to the system data bus will be in the same format.

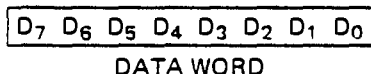

The program instructions may be one, two, or three bytes in length. Multiple byte instructions must be stored in successive words in program memory. The instruction formats then depend on the particular operation executed.

#### One Byte Instructions

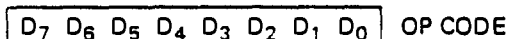

#### Two Byte Instructions

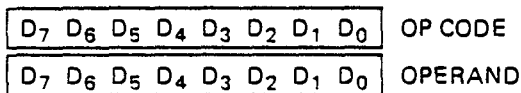

#### Three Byte Instructions

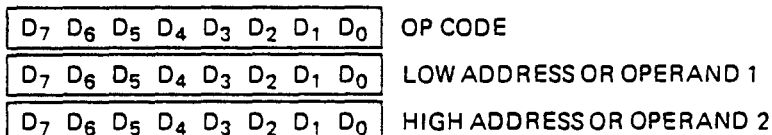

For the 8080A a logic "1" is defined as a high level and a logic "0" is defined as a low level.

### TYPICAL INSTRUCTIONS

Register to register, memory reference, arithmetic or logical, rotate, return, push, pop, enable or disable Interrupt instructions

Immediate mode or I/O instructions

Jump, call or direct load and store instructions

# SILICON GATE MOS 8080A

## INSTRUCTION SET

### Summary of Processor Instructions

| Mnemonic                            | Description                              | Instruction Code <sup>(1)</sup> |                |                |                |                |                |                |                | Clock <sup>(2)</sup><br>Cycles | Mnemonic | Description                           | Instruction Code <sup>(1)</sup> |                |                |                |                |                |                |                | Clock <sup>(2)</sup><br>Cycles |
|-------------------------------------|--|---------------------------------|----------------|----------------|----------------|----------------|----------------|----------------|----------------|--------------------------------|----------|---------------------------------------|---------------------------------|----------------|----------------|----------------|----------------|----------------|----------------|----------------|--------------------------------|
|                                     |  | D <sub>7</sub>                  | D <sub>6</sub> | D <sub>5</sub> | D <sub>4</sub> | D <sub>3</sub> | D <sub>2</sub> | D <sub>1</sub> | D <sub>0</sub> |                                |          |                                       | D <sub>7</sub>                  | D <sub>6</sub> | D <sub>5</sub> | D <sub>4</sub> | D <sub>3</sub> | D <sub>2</sub> | D <sub>1</sub> | D <sub>0</sub> |                                |
| MOV r <sub>1</sub> , r <sub>2</sub> | Move register to register                | 0                               | 1              | 0              | 0              | 0              | S              | S              | S              | 5                              | RZ       | Return on zero                        | 1                               | 1              | 0              | 0              | 1              | 0              | 0              | 0              | 5/11                           |
| MOV M, r                            | Move register to memory                  | 0                               | 1              | 1              | 1              | 0              | S              | S              | S              | 7                              | RNZ      | Return on no zero                     | 1                               | 1              | 0              | 0              | 0              | 0              | 0              | 0              | 5/11                           |
| MOV r, M                            | Move memory to register                  | 0                               | 1              | 0              | 0              | 0              | 1              | 1              | 0              | 7                              | RP       | Return on positive                    | 1                               | 1              | 1              | 1              | 0              | 0              | 0              | 0              | 5/11                           |
| HLT                                 | Halt                                     | 0                               | 1              | 1              | 1              | 0              | 1              | 1              | 0              | 7                              | RM       | Return on minus                       | 1                               | 1              | 1              | 1              | 1              | 0              | 0              | 0              | 5/11                           |
| MVI r                               | Move immediate register                  | 0                               | 0              | 0              | 0              | 0              | 1              | 1              | 0              | 7                              | RPE      | Return on parity even                 | 1                               | 1              | 1              | 0              | 1              | 0              | 0              | 0              | 5/11                           |
| MVI M                               | Move immediate memory                    | 0                               | 0              | 1              | 1              | 0              | 1              | 1              | 0              | 10                             | RPO      | Return on parity odd                  | 1                               | 1              | 1              | 0              | 0              | 0              | 0              | 0              | 5/11                           |
| INR r                               | Increment register                       | 0                               | 0              | 0              | 0              | 0              | 1              | 0              | 0              | 5                              | RST      | Restart                               | 1                               | 1              | A              | A              | A              | 1              | 1              | 1              | 11                             |
| OCR r                               | Decrement register                       | 0                               | 0              | 0              | 0              | 0              | 1              | 0              | 1              | 5                              | IN       | Input                                 | 1                               | 1              | 0              | 1              | 1              | 0              | 1              | 1              | 10                             |
| INR M                               | Increment memory                         | 0                               | 0              | 1              | 1              | 0              | 1              | 0              | 0              | 10                             | OUT      | Output                                | 1                               | 1              | 0              | 1              | 0              | 0              | 1              | 1              | 10                             |
| OCR M                               | Decrement memory                         | 0                               | 0              | 1              | 1              | 0              | 1              | 0              | 1              | 10                             | LXI B    | Load immediate register<br>Pair B & C | 0                               | 0              | 0              | 0              | 0              | 0              | 0              | 1              | 10                             |
| ADD r                               | Add register to A                        | 1                               | 0              | 0              | 0              | 0              | S              | S              | S              | 4                              | LXI D    | Load immediate register<br>Pair D & E | 0                               | 0              | 0              | 1              | 0              | 0              | 0              | 1              | 10                             |
| ADC r                               | Add register to A with carry             | 1                               | 0              | 0              | 0              | 1              | S              | S              | S              | 4                              | LXI H    | Load immediate register<br>Pair H & L | 0                               | 0              | 1              | 0              | 0              | 0              | 0              | 1              | 10                             |
| SUB r                               | Subtract register from A                 | 1                               | 0              | 0              | 1              | 0              | S              | S              | S              | 4                              | LXI SP   | Load immediate stack pointer          | 0                               | 0              | 1              | 1              | 0              | 0              | 0              | 1              | 10                             |
| SBB r                               | Subtract register from A<br>with borrow  | 1                               | 0              | 0              | 1              | 1              | S              | S              | S              | 4                              | PUSH B   | Push register Pair B & C on<br>stack  | 1                               | 1              | 0              | 0              | 0              | 1              | 0              | 1              | 11                             |
| ANA r                               | And register with A                      | 1                               | 0              | 1              | 0              | 0              | S              | S              | S              | 4                              | PUSH D   | Push register Pair D & E on<br>stack  | 1                               | 1              | 0              | 1              | 0              | 1              | 0              | 1              | 11                             |
| XRA r                               | Exclusive Or register with A             | 1                               | 0              | 1              | 0              | 1              | S              | S              | S              | 4                              | PUSH H   | Push register Pair H & L on<br>stack  | 1                               | 1              | 1              | 0              | 0              | 1              | 0              | 1              | 11                             |
| ORA r                               | Or register with A                       | 1                               | 0              | 1              | 1              | 0              | S              | S              | S              | 4                              | PUSH PSW | Push A and Flags<br>on stack          | 1                               | 1              | 1              | 1              | 0              | 1              | 0              | 1              | 11                             |
| CMP r                               | Compare register with A                  | 1                               | 0              | 1              | 1              | 1              | S              | S              | S              | 4                              | POP B    | Pop register pair B & C off<br>stack  | 1                               | 1              | 0              | 0              | 0              | 0              | 0              | 1              | 10                             |
| ADD M                               | Add memory to A                          | 1                               | 0              | 0              | 0              | 0              | 1              | 1              | 0              | 7                              | POP D    | Pop register pair D & E off<br>stack  | 1                               | 1              | 0              | 1              | 0              | 0              | 0              | 1              | 10                             |
| ADC M                               | Add memory to A with carry               | 1                               | 0              | 0              | 0              | 1              | 1              | 1              | 0              | 7                              | POP H    | Pop register pair H & L off<br>stack  | 1                               | 1              | 1              | 0              | 0              | 0              | 0              | 1              | 10                             |
| SUB M                               | Subtract memory from A                   | 1                               | 0              | 0              | 1              | 0              | 1              | 1              | 0              | 7                              | POP PSW  | Pop A and Flags<br>off stack          | 1                               | 1              | 1              | 1              | 0              | 0              | 0              | 1              | 10                             |
| SBB M                               | Subtract memory from A<br>with borrow    | 1                               | 0              | 0              | 1              | 1              | 1              | 1              | 0              | 7                              | STA      | Store A direct                        | 0                               | 0              | 1              | 1              | 0              | 0              | 1              | 0              | 13                             |
| ANA M                               | And memory with A                        | 1                               | 0              | 1              | 0              | 0              | 1              | 1              | 0              | 7                              | LDA      | Load A direct                         | 0                               | 0              | 1              | 1              | 1              | 0              | 1              | 0              | 13                             |
| XRA M                               | Exclusive Or memory with A               | 1                               | 0              | 1              | 0              | 1              | 1              | 1              | 0              | 7                              | XCHG     | Exchange D & E, H & L<br>Registers    | 1                               | 1              | 1              | 0              | 1              | 0              | 1              | 1              | 4                              |
| ORA M                               | Or memory with A                         | 1                               | 0              | 1              | 1              | 0              | 1              | 1              | 0              | 7                              | XTHL     | Exchange top of stack, H & L          | 1                               | 1              | 1              | 0              | 0              | 0              | 1              | 1              | 18                             |
| CMP M                               | Compare memory with A                    | 1                               | 0              | 1              | 1              | 1              | 1              | 1              | 0              | 7                              | SPHL     | H & L to stack pointer                | 1                               | 1              | 1              | 1              | 1              | 0              | 0              | 1              | 5                              |
| ADI                                 | Add immediate to A                       | 1                               | 1              | 0              | 0              | 0              | 1              | 1              | 0              | 7                              | PCHL     | H & L to program counter              | 1                               | 1              | 1              | 0              | 1              | 0              | 0              | 1              | 5                              |
| ACI                                 | Add immediate to A with<br>carry         | 1                               | 1              | 0              | 0              | 1              | 1              | 1              | 0              | 7                              | DAD B    | Add B & C to H & L                    | 0                               | 0              | 0              | 0              | 1              | 0              | 0              | 1              | 10                             |
| SUI                                 | Subtract immediate from A                | 1                               | 1              | 0              | 1              | 0              | 1              | 1              | 0              | 7                              | DAD D    | Add D & E to H & L                    | 0                               | 0              | 0              | 1              | 1              | 0              | 0              | 1              | 10                             |
| SBI                                 | Subtract immediate from A<br>with borrow | 1                               | 1              | 0              | 1              | 1              | 1              | 1              | 0              | 7                              | DAD H    | Add H & L to H & L                    | 0                               | 0              | 1              | 0              | 1              | 0              | 0              | 1              | 10                             |
| ANI                                 | And immediate with A                     | 1                               | 1              | 1              | 0              | 0              | 1              | 1              | 0              | 7                              | DAD SP   | Add stack pointer to H & L            | 0                               | 0              | 1              | 1              | 1              | 0              | 0              | 1              | 10                             |
| XRI                                 | Exclusive Or immediate with<br>A         | 1                               | 1              | 1              | 0              | 1              | 1              | 1              | 0              | 7                              | STAX B   | Store A indirect                      | 0                               | 0              | 0              | 0              | 0              | 0              | 1              | 0              | 7                              |
| ORI                                 | Or immediate with A                      | 1                               | 1              | 1              | 1              | 0              | 1              | 1              | 0              | 7                              | STAX D   | Store A indirect                      | 0                               | 0              | 1              | 0              | 0              | 1              | 0              | 7              |                                |
| CPI                                 | Compare immediate with A                 | 1                               | 1              | 1              | 1              | 1              | 1              | 1              | 0              | 7                              | LDAX B   | Load A indirect                       | 0                               | 0              | 0              | 0              | 1              | 0              | 1              | 0              | 7                              |
| RLC                                 | Rotate A left                            | 0                               | 0              | 0              | 0              | 0              | 1              | 1              | 1              | 4                              | LDAX D   | Load A indirect                       | 0                               | 0              | 0              | 1              | 1              | 0              | 1              | 0              | 7                              |
| RRC                                 | Rotate A right                           | 0                               | 0              | 0              | 0              | 1              | 1              | 1              | 1              | 4                              | INX B    | Increment B & C registers             | 0                               | 0              | 0              | 0              | 0              | 0              | 1              | 1              | 5                              |
| RAL                                 | Rotate A left through carry              | 0                               | 0              | 0              | 1              | 0              | 1              | 1              | 1              | 4                              | INX D    | Increment D & E registers             | 0                               | 0              | 0              | 1              | 0              | 0              | 1              | 1              | 5                              |
| RAR                                 | Rotate A right through<br>carry          | 0                               | 0              | 0              | 1              | 1              | 1              | 1              | 1              | 4                              | INX H    | Increment H & L registers             | 0                               | 0              | 1              | 0              | 0              | 0              | 1              | 1              | 5                              |
| JMP                                 | Jump unconditional                       | 1                               | 1              | 0              | 0              | 0              | 0              | 1              | 1              | 10                             | INX SP   | Increment stack pointer               | 0                               | 0              | 1              | 1              | 0              | 0              | 1              | 1              | 5                              |
| JC                                  | Jump on carry                            | 1                               | 1              | 0              | 1              | 1              | 0              | 1              | 0              | 10                             | DCX B    | Decrement B & C                       | 0                               | 0              | 0              | 0              | 1              | 0              | 1              | 1              | 5                              |
| JNC                                 | Jump on no carry                         | 1                               | 1              | 0              | 1              | 0              | 0              | 1              | 0              | 10                             | DCX D    | Decrement D & E                       | 0                               | 0              | 0              | 1              | 1              | 0              | 1              | 1              | 5                              |
| JZ                                  | Jump on zero                             | 1                               | 1              | 0              | 0              | 1              | 0              | 1              | 0              | 10                             | DCX H    | Decrement H & L                       | 0                               | 0              | 1              | 0              | 1              | 0              | 1              | 1              | 5                              |
| JNZ                                 | Jump on no zero                          | 1                               | 1              | 0              | 0              | 0              | 0              | 1              | 0              | 10                             | DCX SP   | Decrement stack pointer               | 0                               | 0              | 1              | 1              | 1              | 0              | 1              | 1              | 5                              |
| JP                                  | Jump on positive                         | 1                               | 1              | 1              | 1              | 0              | 0              | 1              | 0              | 10                             | CMA      | Complement A                          | 0                               | 0              | 1              | 0              | 1              | 1              | 1              | 1              | 4                              |
| JM                                  | Jump on minus                            | 1                               | 1              | 1              | 1              | 1              | 0              | 1              | 0              | 10                             | STC      | Set carry                             | 0                               | 0              | 1              | 1              | 0              | 1              | 1              | 1              | 4                              |
| JPE                                 | Jump on parity even                      | 1                               | 1              | 1              | 0              | 1              | 0              | 1              | 0              | 10                             | CMC      | Complement carry                      | 0                               | 0              | 1              | 1              | 1              | 1              | 1              | 1              | 4                              |
| JPO                                 | Jump on parity odd                       | 1                               | 1              | 1              | 0              | 0              | 0              | 1              | 0              | 10                             | DAA      | Decimal adjust A                      | 0                               | 0              | 1              | 0              | 0              | 1              | 1              | 1              | 4                              |
| CALL                                | Call unconditional                       | 1                               | 1              | 0              | 0              | 1              | 1              | 0              | 1              | 17                             | SHLD     | Store H & L direct                    | 0                               | 0              | 1              | 0              | 0              | 0              | 1              | 0              | 16                             |
| CC                                  | Call on carry                            | 1                               | 1              | 0              | 1              | 1              | 1              | 0              | 0              | 11/17                          | LHLD     | Load H & L direct                     | 0                               | 0              | 1              | 0              | 1              | 0              | 1              | 0              | 16                             |
| CNC                                 | Call on no carry                         | 1                               | 1              | 0              | 1              | 0              | 1              | 0              | 0              | 11/17                          | EI       | Enable interrupts                     | 1                               | 1              | 1              | 1              | 1              | 0              | 1              | 1              | 4                              |
| CZ                                  | Call on zero                             | 1                               | 1              | 0              | 0              | 1              | 1              | 0              | 0              | 11/17                          | DI       | Disable interrupt                     | 1                               | 1              | 1              | 1              | 0              | 0              | 1              | 1              | 4                              |
| CNZ                                 | Call on no zero                          | 1                               | 1              | 0              | 0              | 0              | 1              | 0              | 0              | 11/17                          | NOP      | No-operation                          | 0                               | 0              | 0              | 0              | 0              | 0              | 0              | 0              | 4                              |
| CP                                  | Call on positive                         | 1                               | 1              | 1              | 1              | 0              | 1              | 0              | 0              | 11/17                          |          |                                       |                                 |                |                |                |                |                |                |                |                                |
| CM                                  | Call on minus                            | 1                               | 1              | 1              | 1              | 1              | 1              | 0              | 0              | 11/17                          |          |                                       |                                 |                |                |                |                |                |                |                |                                |
| CPE                                 | Call on parity even                      | 1                               | 1              | 1              | 0              | 1              | 1              | 0              | 0              | 11/17                          |          |                                       |                                 |                |                |                |                |                |                |                |                                |
| CPO                                 | Call on parity odd                       | 1                               | 1              | 1              | 0              | 0              | 1              | 0              | 0              | 11/17                          |          |                                       |                                 |                |                |                |                |                |                |                |                                |
| RET                                 | Return                                   | 1                               | 1              | 0              | 0              | 1              | 0              | 0              | 1              | 10                             |          |                                       |                                 |                |                |                |                |                |                |                |                                |
| RC                                  | Return on carry                          | 1                               | 1              | 0              | 1              | 1              | 0              | 0              | 0              | 5/11                           |          |                                       |                                 |                |                |                |                |                |                |                |                                |
| RNC                                 | Return on no carry                       | 1                               | 1              | 0              | 1              | 0              | 0              | 0              | 0              | 5/11                           |          |                                       |                                 |                |                |                |                |                |                |                |                                |

NOTES: 1. DDD or SSS — 000 B — 001 C — 010 D — 011 E — 100 H — 101 L — 110 Memory — 111 A.  
2. Two possible cycle times, (5/11) indicate instruction cycles dependent on condition flags.

## EIGHT-BIT INPUT/OUTPUT PORT

- Fully Parallel 8-Bit Data Register and Buffer
- Service Request Flip-Flop for Interrupt Generation
- Low Input Load Current — .25 mA Max.
- Three State Outputs
- Outputs Sink 15 mA
- 3.65V Output High Voltage for Direct Interface to 8080 CPU or 8008 CPU
- Asynchronous Register Clear
- Replaces Buffers, Latches and Multiplexers in Micro-computer Systems
- Reduces System Package Count

The 8212 input/output port consists of an 8-bit latch with 3-state output buffers along with control and device selection logic. Also included is a service request flip-flop for the generation and control of interrupts to the microprocessor.

The device is multimode in nature. It can be used to implement latches, gated buffers or multiplexers. Thus, all of the principal peripheral and input/output functions of a microcomputer system can be implemented with this device.

### PIN CONFIGURATION

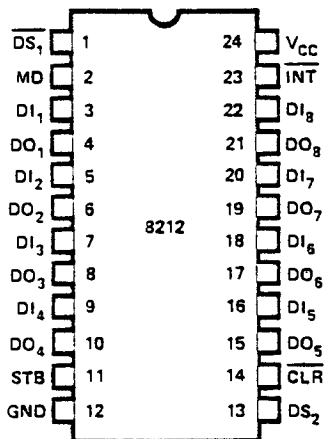

### PIN NAMES

|                                  |                        |
|----------------------------------|------------------------|
| DI <sub>1</sub> -DI <sub>8</sub> | DATA IN                |
| DO <sub>1</sub> -DO <sub>8</sub> | DATA OUT               |
| DS <sub>1</sub> -DS <sub>2</sub> | DEVICE SELECT          |
| MD                               | MODE                   |
| STB                              | STROBE                 |
| INT                              | INTERRUPT (ACTIVE LOW) |
| CLR                              | CLEAR (ACTIVE LOW)     |

### LOGIC DIAGRAM

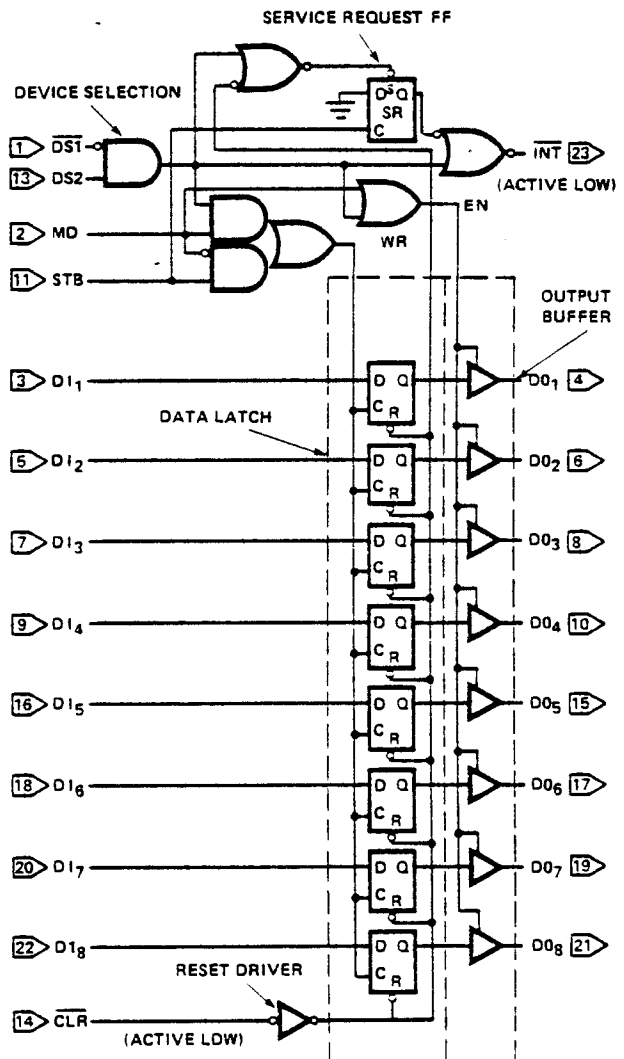

# SCHOTTKY BIPOLAR 8212

## Functional Description

### Data Latch

The 8 flip-flops that make up the data latch are of a "D" type design. The output (Q) of the flip-flop will follow the data input (D) while the clock input (C) is high. Latching will occur when the clock (C) returns low.

The data latch is cleared by an asynchronous reset input ( $\overline{\text{CLR}}$ ). (Note: Clock (C) Overrides Reset ( $\overline{\text{CLR}}$ ).)

### Output Buffer

The outputs of the data latch (Q) are connected to 3-state, non-inverting output buffers. These buffers have a common control line (EN); this control line either enables the buffer to transmit the data from the outputs of the data latch (Q) or disables the buffer, forcing the output into a high impedance state. (3-state)

This high-impedance state allows the designer to connect the 8212 directly onto the microprocessor bi-directional data bus.

### Control Logic

The 8212 has control inputs  $\overline{\text{DS1}}$ , DS2, MD and STB. These inputs are used to control device selection, data latching, output buffer state and service request flip-flop.

### $\overline{\text{DS1}}$ , DS2 (Device Select)

These 2 inputs are used for device selection. When  $\overline{\text{DS1}}$  is low and DS2 is high ( $\overline{\text{DS1}} \cdot \text{DS2}$ ) the device is selected. In the selected state the output buffer is enabled and the service request flip-flop (SR) is asynchronously set.

### MD (Mode)

This input is used to control the state of the output buffer and to determine the source of the clock input (C) to the data latch.

When MD is high (output mode) the output buffers are enabled and the source of clock (C) to the data latch is from the device selection logic ( $\overline{\text{DS1}} \cdot \text{DS2}$ ).

When MD is low (input mode) the output buffer state is determined by the device selection logic ( $\overline{\text{DS1}} \cdot \text{DS2}$ ) and the source of clock (C) to the data latch is the STB (Strobe) input.

### STB (Strobe)

This input is used as the clock (C) to the data latch for the input mode MD = 0) and to synchronously reset the service request flip-flop (SR).

Note that the SR flip-flop is negative edge triggered.

## Service Request Flip-Flop

The (SR) flip-flop is used to generate and control interrupts in microcomputer systems. It is asynchronously set by the CLR input (active low). When the (SR) flip-flop is set it is in the non-interrupting state.

The output of the (SR) flip-flop (Q) is connected to an inverting input of a "NOR" gate. The other input to the "NOR" gate is non-inverting and is connected to the device selection logic ( $\overline{\text{DS1}} \cdot \text{DS2}$ ). The output of the "NOR" gate (INT) is active low (interrupting state) for connection to active low input priority generating circuits.

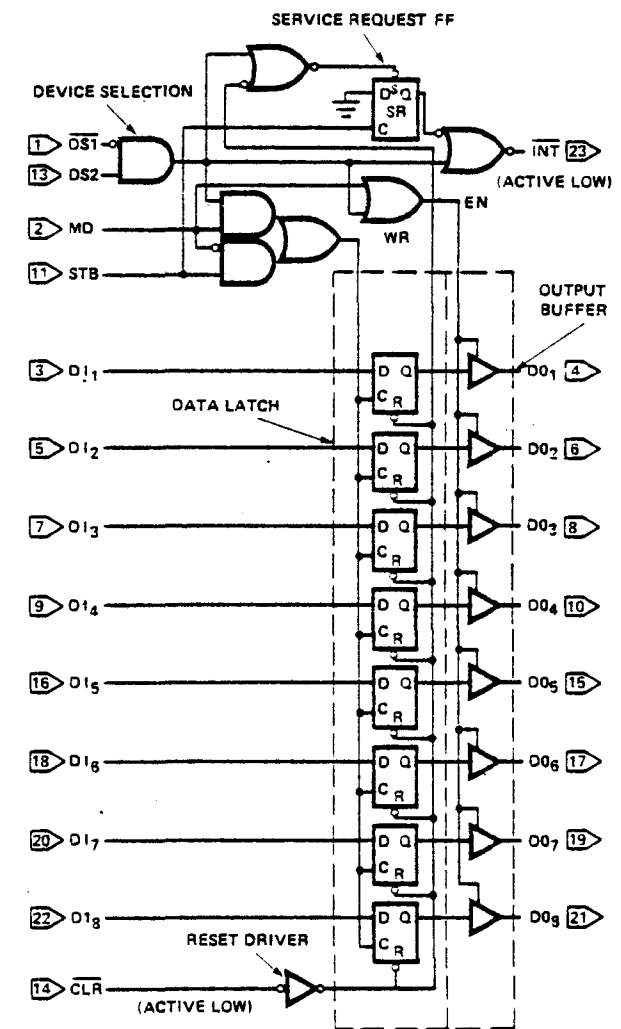

| STB | MD | ( $\overline{\text{DS1}} \cdot \text{DS2}$ ) | DATA OUT EQUALS | CLR | ( $\overline{\text{DS1}} \cdot \text{DS2}$ ) | STB | *SR | INT |
|-----|----|--|-----------------|-----|--|-----|-----|-----|
| 0   | 0  | 0  | 3-STATE         | 0   | 0  | 0   | 1   | 1   |
| 1   | 0  | 0  | 3-STATE         | 0   | 1  | 0   | 1   | 0   |
| 0   | 1  | 0  | DATA LATCH      | 1   | 1  | 0   | 0   | 0   |
| 1   | 1  | 0  | DATA LATCH      | 1   | 1  | 0   | 1   | 0   |
| 0   | 0  | 1  | DATA LATCH      | 1   | 0  | 0   | 1   | 1   |
| 1   | 0  | 1  | DATA IN         | 1   | 1  | 1   | 1   | 0   |
| 0   | 1  | 1  | DATA IN         | 1   | 1  | 1   | 1   | 0   |
| 1   | 1  | 1  | DATA IN         | 1   | 1  | 1   | 1   | 0   |

\*INTERNAL SR FLIP-FLOP  
CLR - RESETS DATA LATCH  
SETS SR FLIP-FLOP  
(NO EFFECT ON OUTPUT BUFFER)

## Applications Of The 8212 -- For Microcomputer Systems

- |     |                            |      |                            |
|-----|----------------------------|------|----------------------------|
| I   | Basic Schematic Symbol     | VII  | 8080 Status Latch          |
| II  | Gated Buffer               | VIII | 8008 System                |
| III | Bi-Directional Bus Driver  | IX   | 8080 System:               |
| IV  | Interrupting Input Port    |      | 8 Input Ports              |
| V   | Interrupt Instruction Port |      | 8 Output Ports             |
| VI  | Output Port                |      | 8 Level Priority Interrupt |

### I. Basic Schematic Symbols

Two examples of ways to draw the 8212 on system schematics—(1) the top being the detailed view showing pin numbers, and (2) the bottom being the symbolic view showing the system input or output

as a system bus (bus containing 8 parallel lines). The output to the data bus is symbolic in referencing 8 parallel lines.

#### BASIC SCHEMATIC SYMBOLS

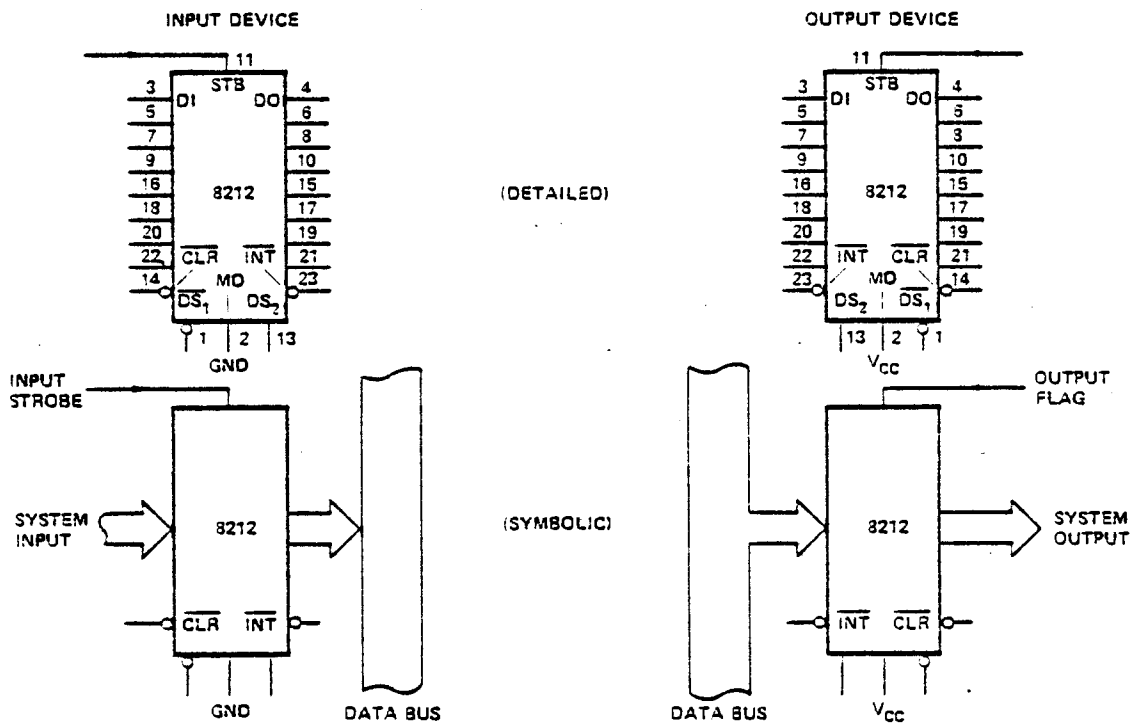

### II. Gated Buffer ( 3 - STATE )

The simplest use of the 8212 is that of a gated buffer. By tying the mode signal low and the strobe input high, the data latch is acting as a straight through gate. The output buffers are then enabled from the device selection logic  $\overline{DS1}$  and  $\overline{DS2}$ .

When the device selection logic is false, the outputs are 3-state.

When the device selection logic is true, the input data from the system is directly transferred to the output. The input data load is 250 micro amps. The output data can sink 15 milli amps. The minimum high output is 3.65 volts.

#### GATED BUFFER 3-STATE

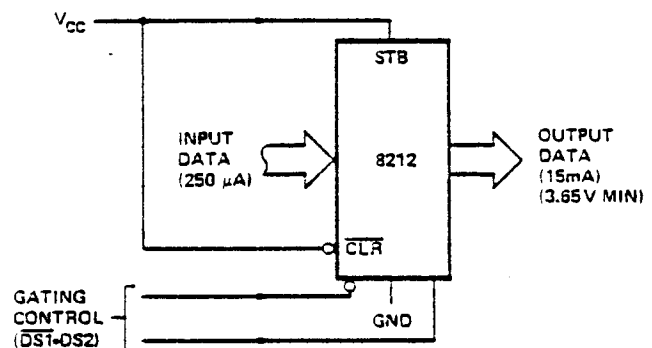



# SCHOTTKY BIPOLAR 8212

## III. Bi-Directional Bus Driver

A pair of 8212's wired (back-to-back) can be used as a symmetrical drive, bi-directional bus driver. The devices are controlled by the data bus input control which is connected to  $\overline{DS1}$  on the first 8212 and to DS2 on the second. One device is active, and acting as a straight through buffer the other is in 3-state mode. This is a very useful circuit in small system design.

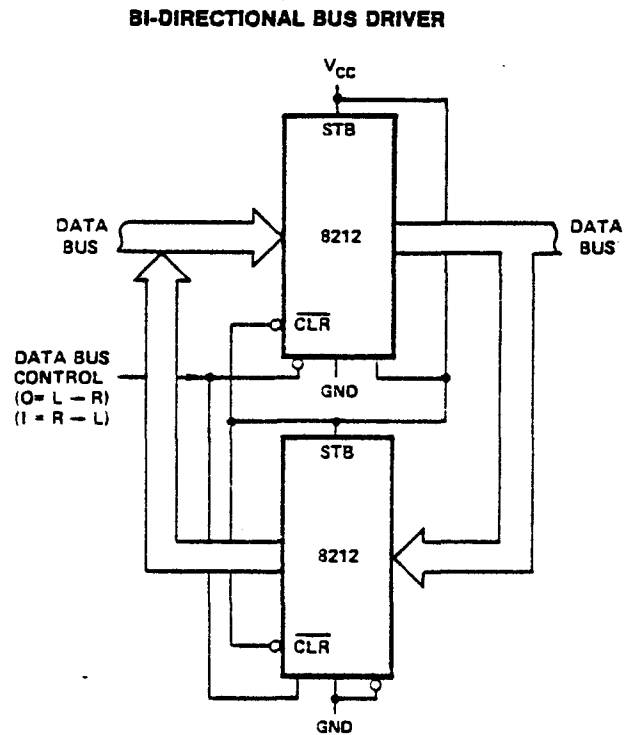

## IV. Interrupting Input Port

This use of an 8212 is that of a system input port that accepts a strobe from the system input source, which in turn clears the service request flip-flop and interrupts the processor. The processor then goes through a service routine, identifies the port, and causes the device selection logic to go true — enabling the system input data onto the data bus.

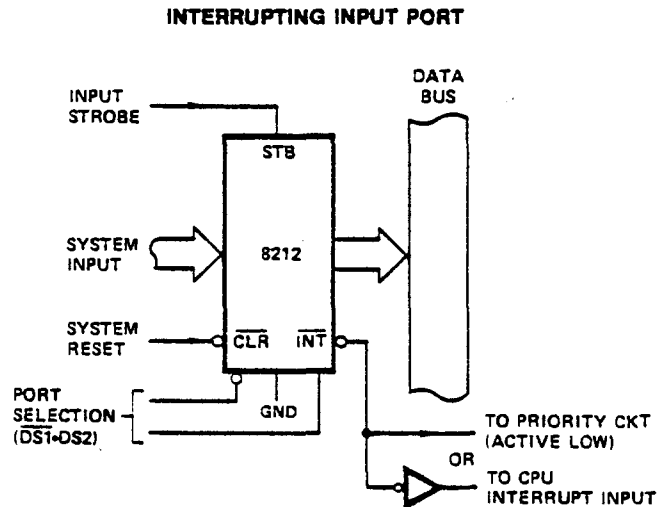

## V. Interrupt Instruction Port

The 8212 can be used to gate the interrupt instruction, normally RESTART instructions, onto the data bus. The device is enabled from the interrupt acknowledge signal from the microprocessor and from a port selection signal. This signal is normally tied to ground. ( $\overline{DS1}$  could be used to multiplex a variety of interrupt instruction ports onto a common bus).

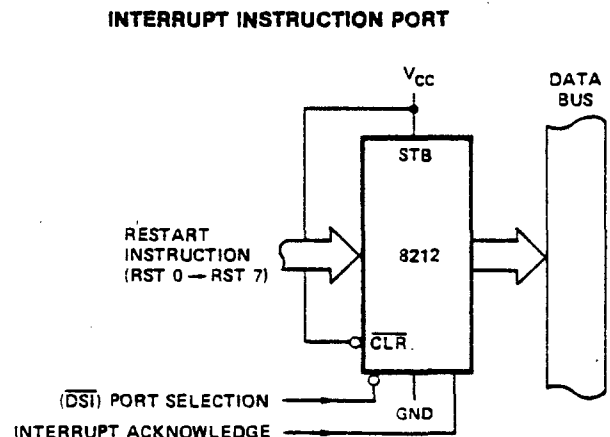

## VI. Output Port (With Hand-Shaking)

The 8212 can be used to transmit data from the data bus to a system output. The output strobe could be a hand-shaking signal such as "reception of data" from the device that the system is outputting to. It in turn, can interrupt the system signifying the reception of data. The selection of the port comes from the device selection logic. ( $\overline{DS1} \cdot DS2$ )

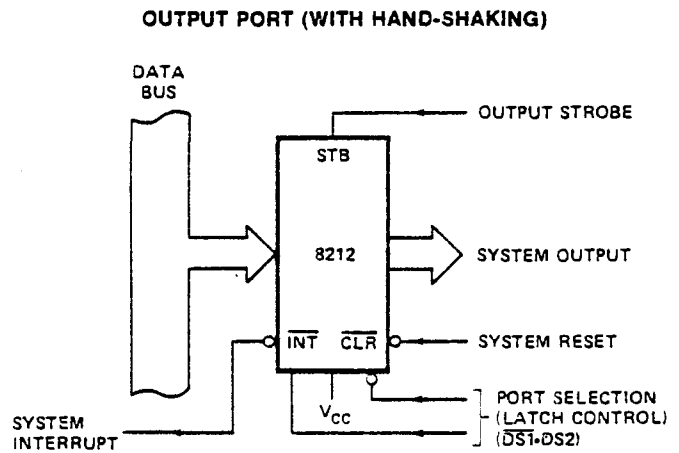

## VII. 8080 Status Latch

Here the 8212 is used as the status latch for an 8080 microcomputer system. The input to the 8212 latch is directly from the 8080 data bus. Timing shows that when the SYNC signal is true, which is connected to the DS2 input and the phase 1 signal is true, which is a TTL level coming from the clock generator; then, the status data will be latched into the 8212.

Note: The mode signal is tied high so that the output on the latch is active and enabled all the time. It is shown that the two areas of concern are the bidirectional data bus of the microprocessor and the control bus.

8080 STATUS LATCH

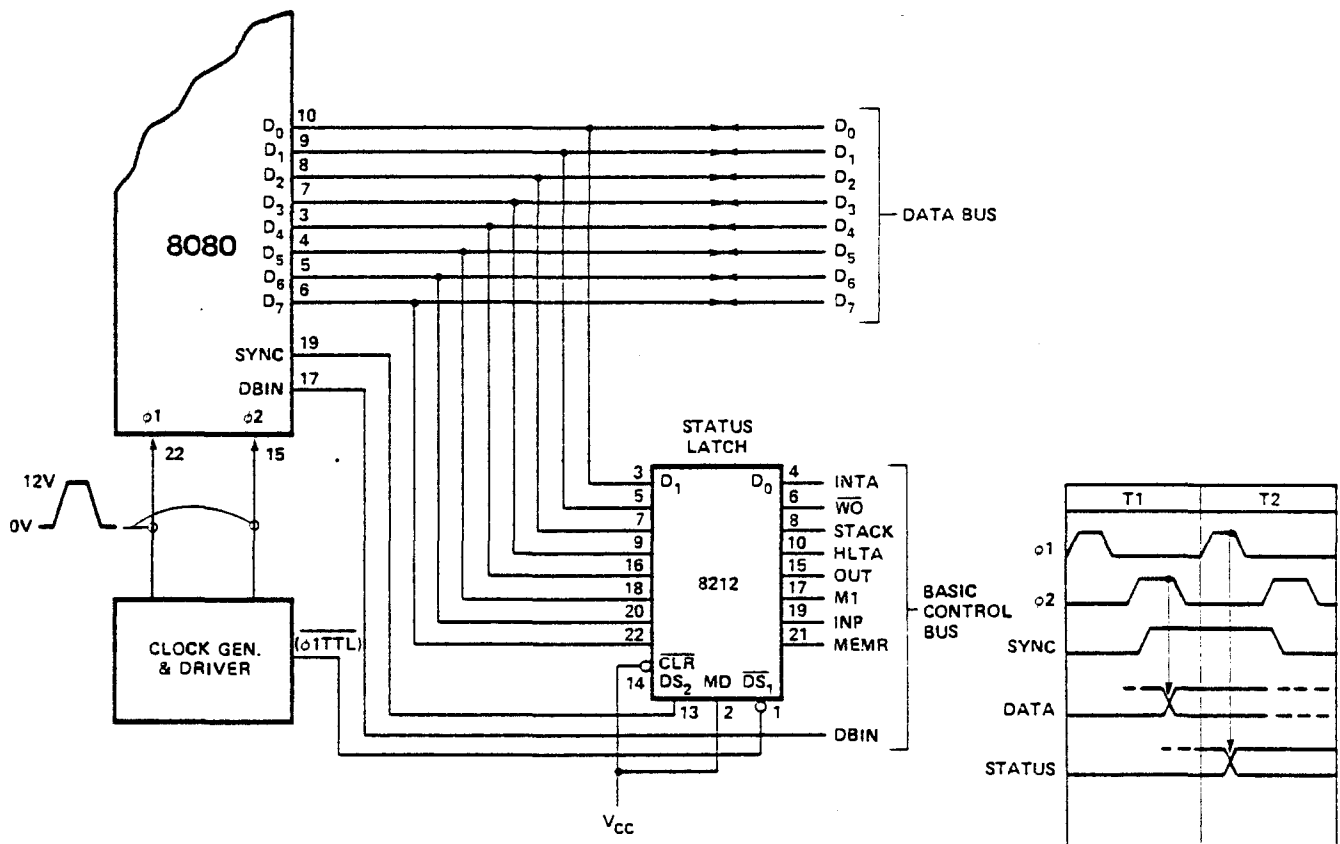

# SCHOTTKY BIPOLAR 8212

## VIII. 8008 System

This shows the 8212 used in an 8008 microcomputer system. They are used to multiplex the data from three different sources onto the 8008 input data bus. The three sources of data are: memory data, input data, and the interrupt instruction. The 8212 is also used as the uni-directional bus driver to provide a proper drive to the address latches (both low order and high order are also 8212's) and to provide adequate drive to the output data bus. The control of these six 8212's in the 8008 system is provided by the control logic and clock generator circuits. These circuits consist of flip-flops, decoders, and gates to generate the control functions necessary for 8008 microcomputer systems. Also note that the input data port has a strobe input. This allows the proces-

sor to be interrupted from the input port directly. The control of the input bus consists of the data bus input signal, control logic, and the appropriate status signal for bus discipline whether memory read, input, or interrupt acknowledge. The combination of these four signals determines which one of these three devices will have access to the input data bus. The bus driver, which is implemented in an 8212, is also controlled by the control logic and clock generator so it can be 3-stated when necessary and also as a control transmission device to the address latches. Note: The address latches can be 3-stated for DMA purposes and they provide 15 milli amps drive, sufficient for large bus systems.

8008 SYSTEM

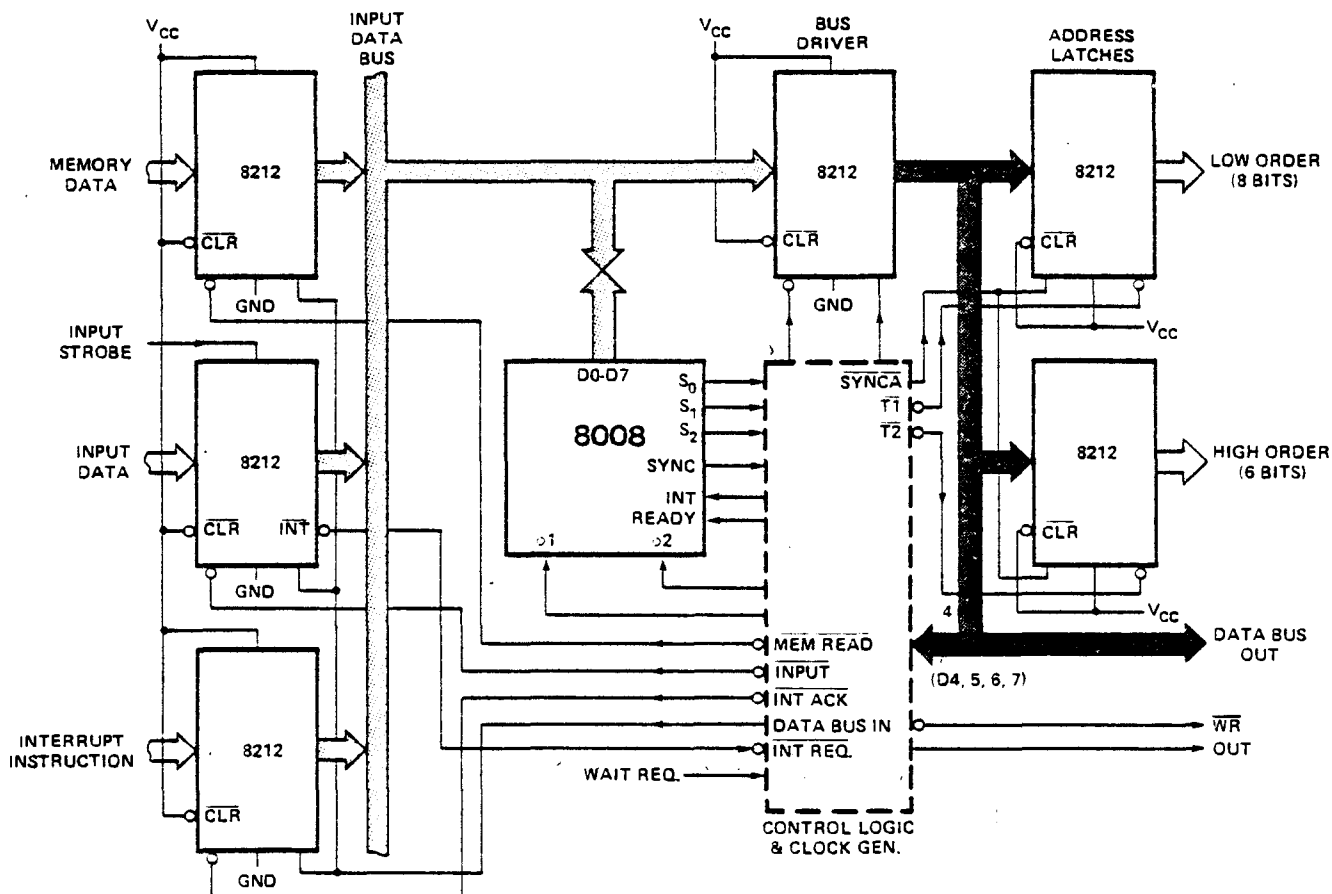

## IX. 8080 System

This drawing shows the 8212 used in the I/O section of an 8080 microcomputer system. The system consists of 8 input ports, 8 output ports, 8 level priority systems, and a bidirectional bus driver. (The data bus within the system is darkened for emphasis). Basically, the operation would be as follows: The 8 ports, for example, could be connected to 8 keyboards, each keyboard having its own priority level. The keyboard could provide a strobe input of its own which would clear the service request flip-flop. The  $\overline{\text{INT}}$  signals are connected to an 8 level priority encoding circuit. This circuit provides a positive true level to the central processor (INT) along with a three-bit code to the interrupt instruction port for the generation of RESTART instructions. Once the processor has been interrupted and it acknowledges the reception of the interrupt, the Interrupt Acknowledge signal is generated. This signal transfers data in the form of a RESTART instruction onto the buffered data bus. When the DBIN signal is true this RESTART instruction is gated into the microcomputer, in this case, the 8080 CPU. The 8080 then performs a software controlled interrupt service routine, saving the status of its current operation in the push-down stack and performing an INPUT instruction. The INPUT instruction thus sets the INP status

bit, which is common to all input ports.

Also present is the address of the device on the 8080 address bus which in this system is connected to an 8205, one out of eight decoder with active low outputs. These active low outputs will enable one of the input ports, the one that interrupted the processor, to put its data onto the buffered data bus to be transmitted to the CPU when the data bus input signal is true. The processor can also output data from the 8080 data bus to the buffered data bus when the data bus input signal is false. Using the same address selection technique from the 8205 decoder and the output status bit, we can select with this system one of eight output ports to transmit the data to the system's output device structure.

Note: This basic I/O configuration for the 8080 can be expanded to 256 input devices and 256 output devices all using 8212 and, of course, the appropriate decoding.

Note that the 8080 is a 3.3-volt minimum high input requirement and that the 8212 has a 3.65-volt minimum high output providing the designer with a 350 milli volt noise margin worst case for 8080 systems when using the 8212.

# SCHOTTKY BIPOLAR 8212

## 8080 SYSTEM

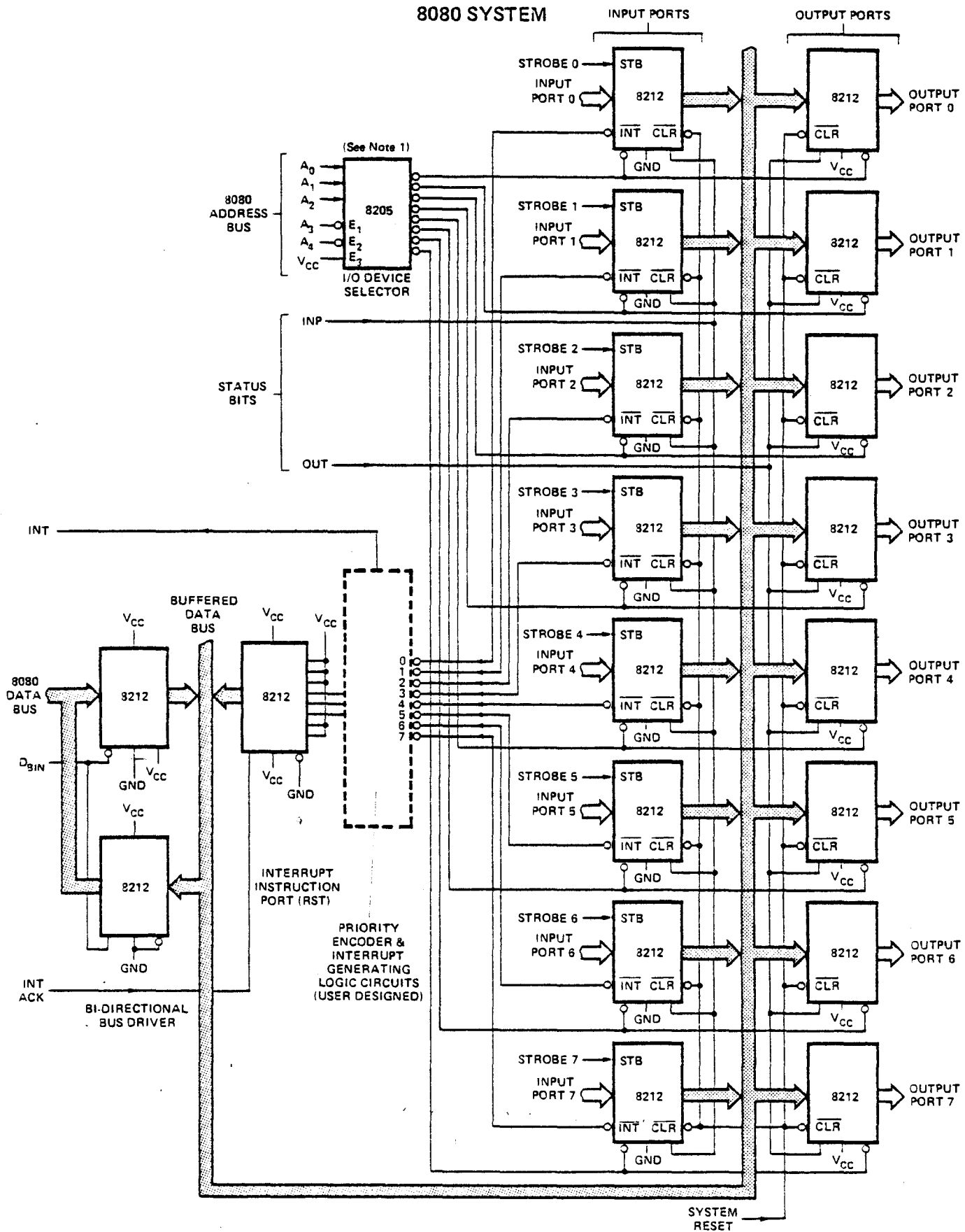

Note 1. This basic I/O configuration for the 8080 can be expanded to 256 input devices and 256 output devices all using 8212 and the appropriate decoding.

# SCHOTTKY BIPOLAR 8212

## Absolute Maximum Ratings\*

Temperature Under Bias Plastic . . . -65°C to +75°C  
 Storage Temperature . . . . . -65°C to +160°C  
 All Output or Supply Voltages . . . . -0.5 to +7 Volts  
 All Input Voltages . . . . . -1.0 to 5.5 Volts  
 Output Currents . . . . . 125 mA

\*COMMENT: Stresses above those listed under "Absolute Maximum Ratings" may cause permanent damage to the device. This is a stress rating only and functional operation of the device at these or at any other condition above those indicated in the operational sections of this specification is not implied.

## D.C. Characteristics

T<sub>A</sub> = 0°C to +75°C V<sub>CC</sub> = +5V ±5%

| Symbol          | Parameter  | Limits |      |       | Unit | Test Conditions             |
|-----------------|--|--------|------|-------|------|-----------------------------|
|                 |  | Min.   | Typ. | Max.  |      |                             |
| I <sub>F</sub>  | Input Load Current<br>ACK, DS <sub>2</sub> , CR, DI <sub>1</sub> -DI <sub>3</sub> Inputs |        |      | - .25 | mA   | V <sub>F</sub> = .45V       |
| I <sub>F</sub>  | Input Load Current<br>MD Input   |        |      | - .75 | mA   | V <sub>F</sub> = .45V       |
| I <sub>F</sub>  | Input Load Current<br>DS <sub>1</sub> Input  |        |      | - 1.0 | mA   | V <sub>F</sub> = .45V       |
| I <sub>R</sub>  | Input Leakage Current<br>ACK, DS, CR, DI <sub>1</sub> -DI <sub>3</sub> Inputs            |        |      | 10    | μA   | V <sub>R</sub> = 5.25V      |
| I <sub>R</sub>  | Input Leakage Current<br>MO Input  |        |      | 30    | μA   | V <sub>R</sub> = 5.25V      |
| I <sub>R</sub>  | Input Leakage Current<br>DS <sub>1</sub> Input   |        |      | 40    | μA   | V <sub>R</sub> = 5.25V      |
| V <sub>C</sub>  | Input Forward Voltage Clamp  |        |      | - 1   | V    | I <sub>C</sub> = -5 mA      |
| V <sub>IL</sub> | Input "Low" Voltage  |        |      | .85   | V    |                             |
| V <sub>IH</sub> | Input "High" Voltage   | 2.0    |      |       | V    |                             |
| V <sub>OL</sub> | Output "Low" Voltage   |        |      | .45   | V    | I <sub>OL</sub> = 15 mA     |
| V <sub>OH</sub> | Output "High" Voltage  | 3.65   | 4.0  |       | V    | I <sub>OH</sub> = -1 mA     |
| I <sub>SC</sub> | Short Circuit Output Current   | -15    |      | -75   | mA   | V <sub>O</sub> = 0 V        |
| I <sub>oi</sub> | Output Leakage Current<br>High Impedance State   |        |      | 20    | μA   | V <sub>O</sub> = .45V/5.25V |
| I <sub>CC</sub> | Power Supply Current   |        | 90   | 130   | mA   |                             |

# SCHOTTKY BIPOLAR 8212

## Typical Characteristics

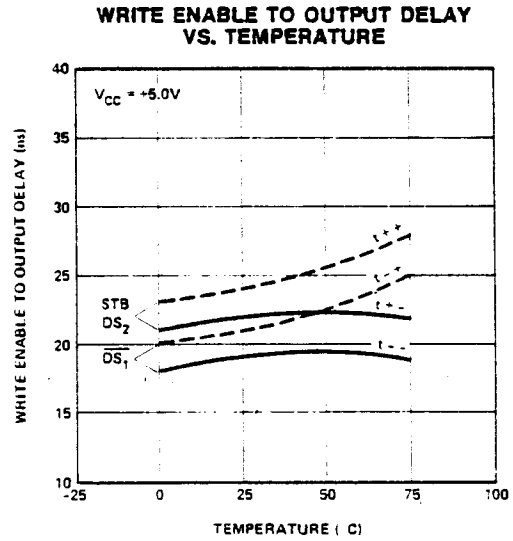
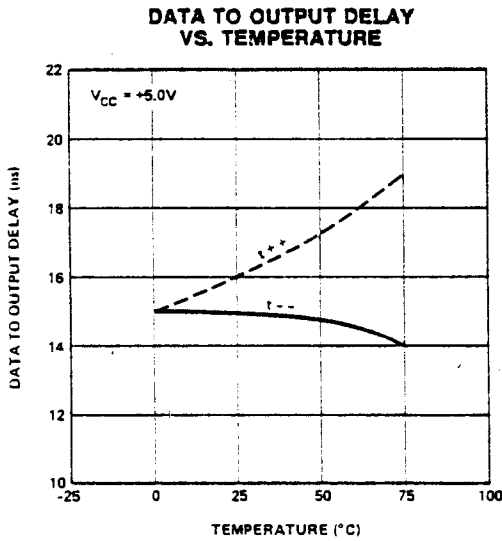
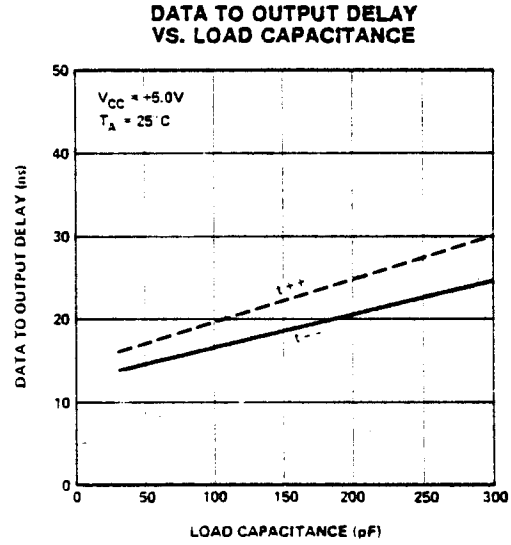
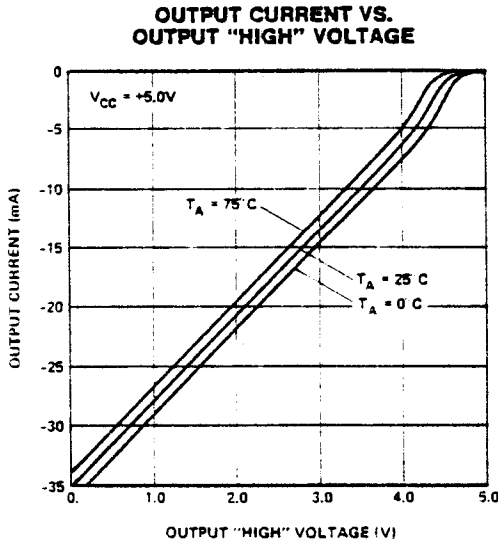
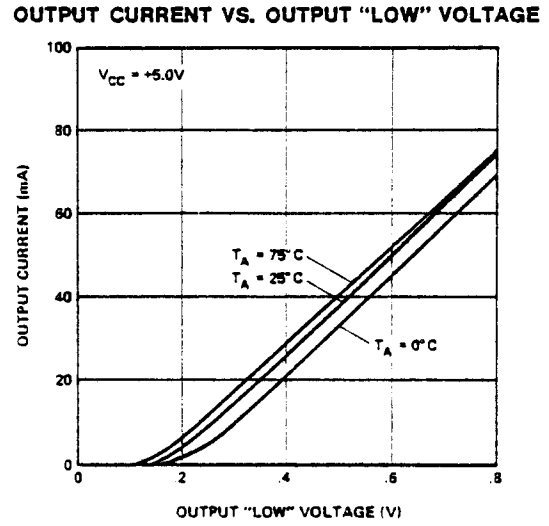
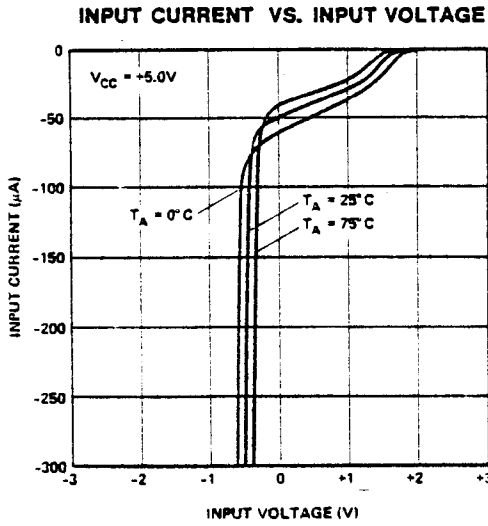

# SCHOTTKY BIPOLAR 8212

## Timing Diagram

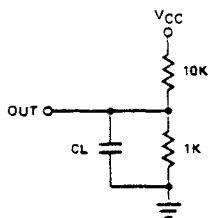
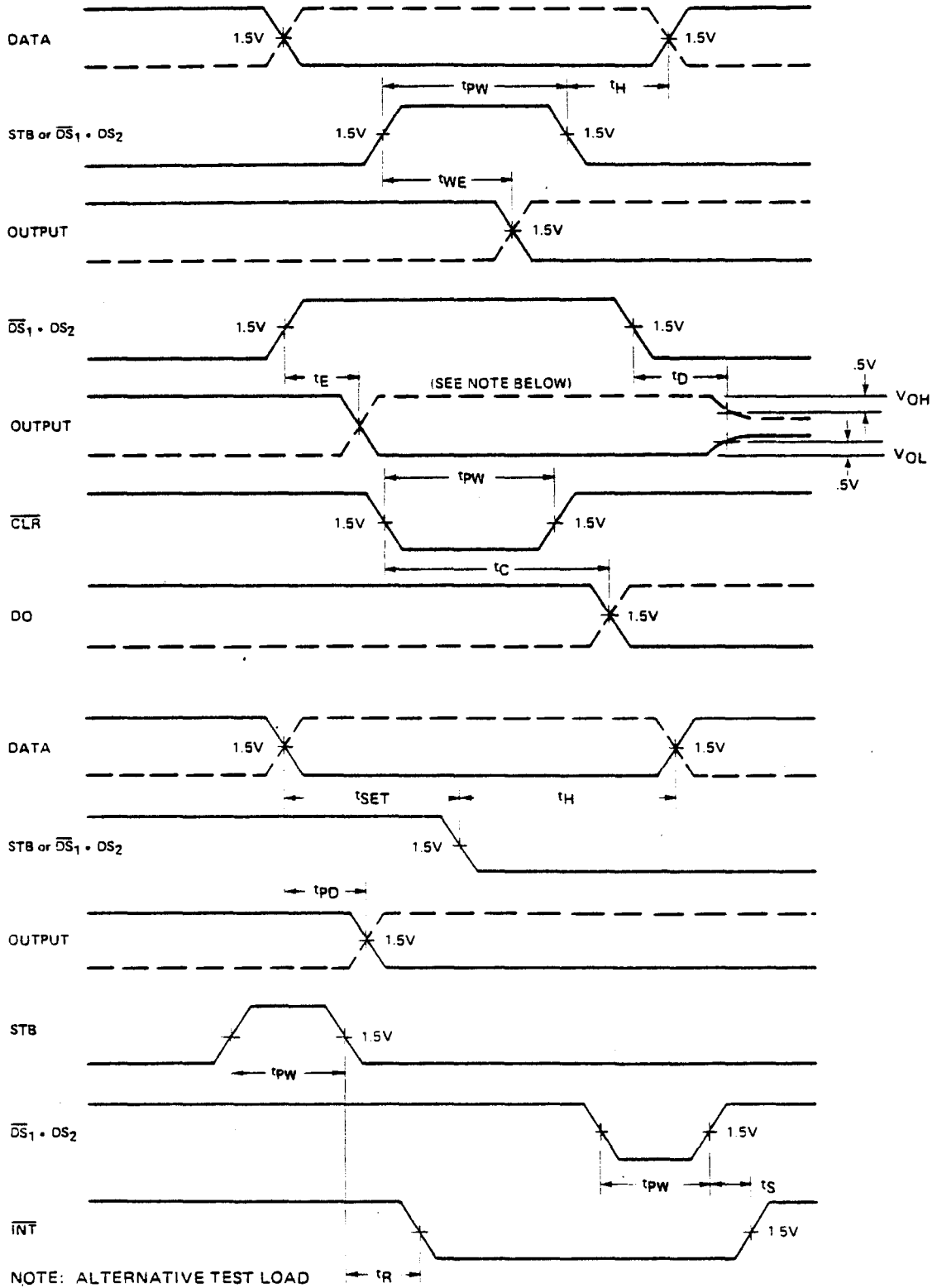



# SCHOTTKY BIPOLAR 8212

## A.C. Characteristics

$T_A = 0^\circ\text{C to } +75^\circ\text{C}$   $V_{CC} = +5V \pm 5\%$

| Symbol   | Parameter                    | Limits |      |      | Unit | Test Conditions |
|----------|------------------------------|--------|------|------|------|-----------------|
|          |                              | Min.   | Typ. | Max. |      |                 |
| $t_{pw}$ | Pulse Width                  | 30     |      |      | ns   |                 |
| $t_{oa}$ | Data To Output Delay         |        |      | 30   | ns   |                 |
| $t_{oe}$ | Write Enable To Output Delay |        |      | 40   | ns   |                 |
| $t_{sa}$ | Data Setup Time              | 15     |      |      | ns   |                 |
| $t_h$    | Data Hold Time               | 20     |      |      | ns   |                 |
| $t_r$    | Reset To Output Delay        |        |      | 40   | ns   |                 |
| $t_s$    | Set To Output Delay          |        |      | 30   | ns   |                 |
| $t_e$    | Output Enable/Disable Time   |        |      | 45   | ns   |                 |
| $t_c$    | Clear To Output Delay        |        |      | 55   | ns   |                 |

CAPACITANCE\*  $F = 1\text{ MHz}$   $V_{BIAS} = 2.5V$   $V_{CC} = +5V$   $T_A = 25^\circ\text{C}$

| Symbol    | Test  | LIMITS |       |
|-----------|---|--------|-------|
|           |   | Typ.   | Max.  |
| $C_{IN}$  | DS, MD Input Capacitance  | 9 pF   | 12 pF |
| $C_{IN}$  | DS <sub>2</sub> , CK, ACK, DI <sub>1</sub> -DI <sub>3</sub> Input Capacitance | 5 pF   | 9 pF  |
| $C_{OUT}$ | DO <sub>1</sub> -DO <sub>3</sub> Output Capacitance                           | 8 pF   | 12 pF |

\*This parameter is sampled and not 100% tested.

## Switching Characteristics

### CONDITIONS OF TEST

Input Pulse Amplitude = 2.5 V

Input Rise and Fall Times 5 ns

Between 1V and 2V Measurements made at 1.5V  
with 15 mA & 30 pF Test Load

### TEST LOAD

15 mA & 30 pF

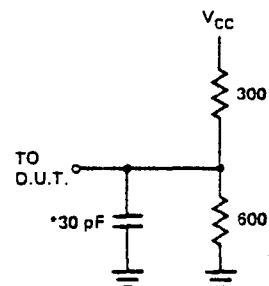

\* INCLUDING JIG & PROBE CAPACITANCE

## 4 BIT PARALLEL BIDIRECTIONAL BUS DRIVER

- Data Bus Buffer Driver for 8080 CPU
- Low Input Load Current — .25 mA Maximum
- High Output Drive Capability for Driving System Data Bus
- 3.65V Output High Voltage for Direct Interface to 8080 CPU
- Three State Outputs
- Reduces System Package Count

The 8216/8226 is a 4-bit bi-directional bus driver/receiver.

All inputs are low power TTL compatible. For driving MOS, the DO outputs provide a high 3.65V  $V_{OH}$ , and for high capacitance terminated bus structures, the DB outputs provide a high 50mA  $I_{OL}$  capability.

A non-inverting (8216) and an inverting (8226) are available to meet a wide variety of applications for buffering in micro-computer systems.

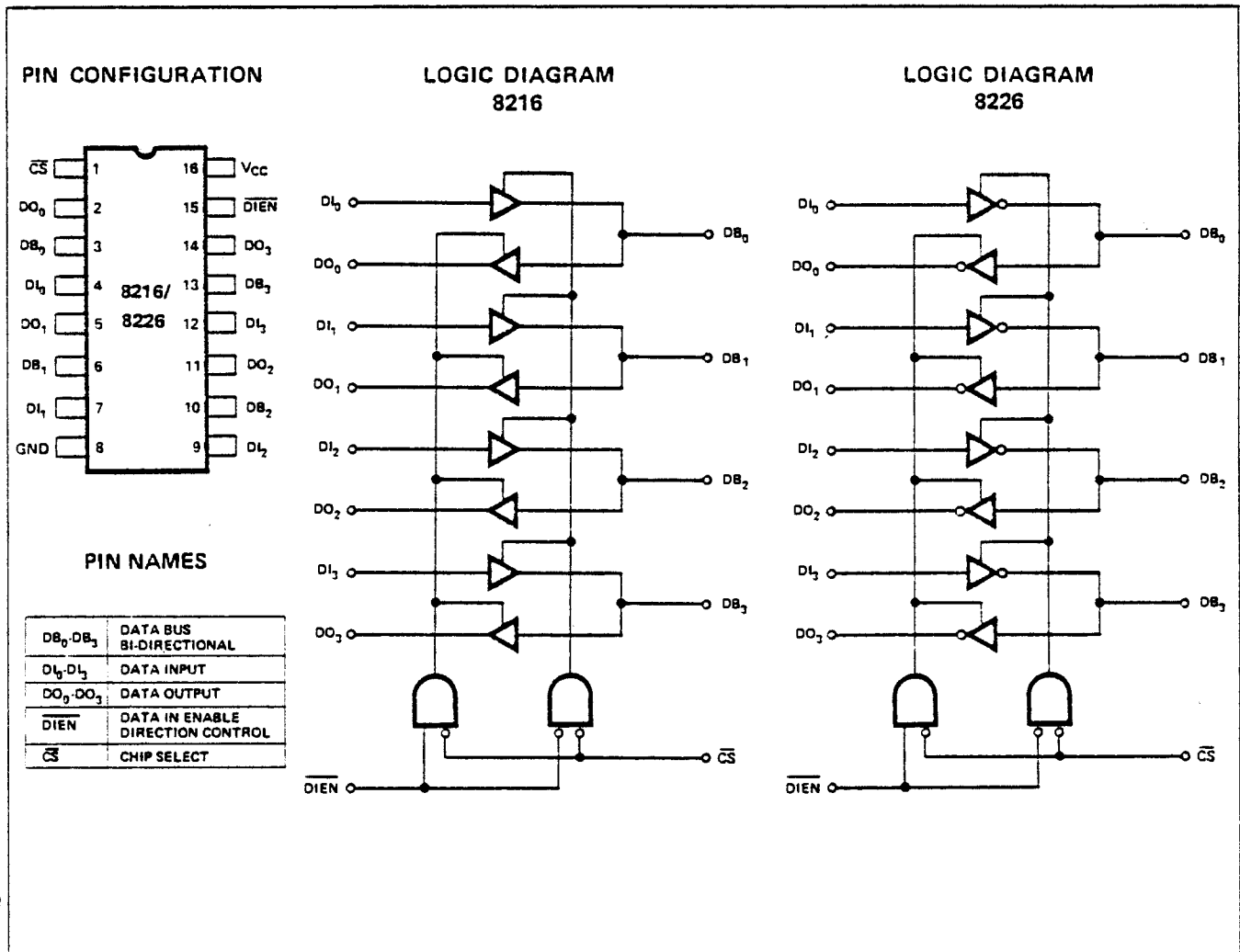

# SCHOTTKY BIPOLAR 8216/8226

## FUNCTIONAL DESCRIPTION

Microprocessors like the 8080 are MOS devices and are generally capable of driving a single TTL load. The same is true for MOS memory devices. While this type of drive is sufficient in small systems with few components, quite often it is necessary to buffer the microprocessor and memories when adding components or expanding to a multi-board system.

The 8216/8226 is a four bit bi-directional bus driver specifically designed to buffer microcomputer system components.

### Bi-Directional Driver

Each buffered line of the four bit driver consists of two separate buffers that are tri-state in nature to achieve direct bus interface and bi-directional capability. On one side of the driver the output of one buffer and the input of another are tied together (DB), this side is used to interface to the system side components such as memories, I/O, etc., because its interface is direct TTL compatible and it has high drive (50mA). On the other side of the driver the inputs and outputs are separated to provide maximum flexibility. Of course, they can be tied together so that the driver can be used to buffer a true bi-directional bus such as the 8080 Data Bus. The DO outputs on this side of the driver have a special high voltage output drive capability (3.65V) so that direct interface to the 8080 and 8008 CPUs is achieved with an adequate amount of noise immunity (350mV worst case).

### Control Gating $\overline{DIEN}$ , $\overline{CS}$

The  $\overline{CS}$  input is actually a device select. When it is "high" the output drivers are all forced to their high-impedance state. When it is at "zero" the device is selected (enabled) and the direction of the data flow is determined by the  $\overline{DIEN}$  input.

The  $\overline{DIEN}$  input controls the direction of data flow (see Figure 1) for complete truth table. This direction control is accomplished by forcing one of the pair of buffers into its high impedance state and allowing the other to transmit its data. A simple two gate circuit is used for this function.

The 8216/8226 is a device that will reduce component count in microcomputer systems and at the same time enhance noise immunity to assure reliable, high performance operation.

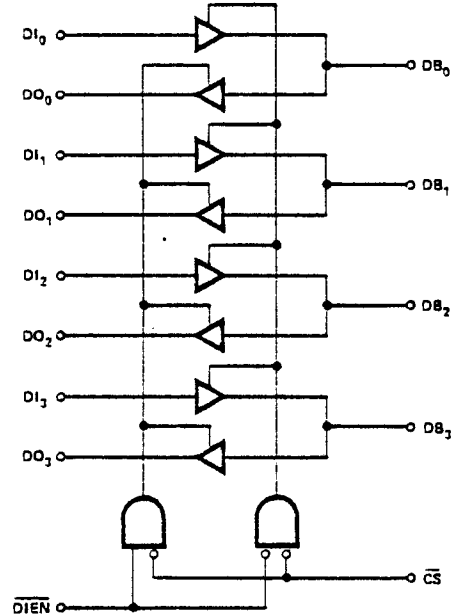

(a) 8216

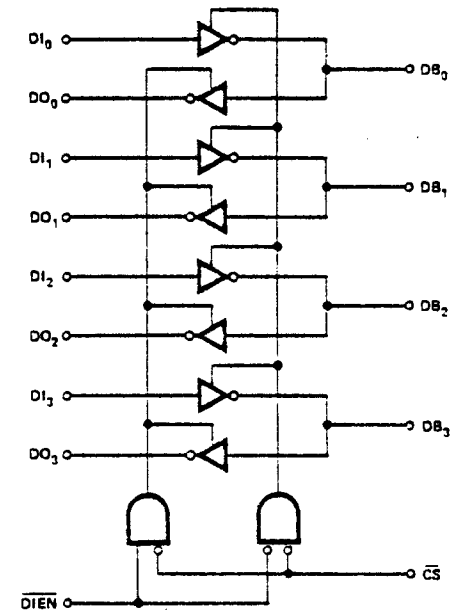

(b) 8226

| $\overline{DIEN}$ | $\overline{CS}$ |                  |
|-------------------|-----------------|------------------|
| 0                 | 0               | DI = DB          |
| 1                 | 0               | OB = DO          |
| 0                 | 1               | - HIGH IMPEDANCE |
| 1                 | 1               | - HIGH IMPEDANCE |

Figure 1. 8216/8226 Logic Diagrams

# SCHOTTKY BIPOLAR 8216/8226

## D.C. AND OPERATING CHARACTERISTICS

### ABSOLUTE MAXIMUM RATINGS\*

|                                |                 |
|--------------------------------|-----------------|
| Temperature Under Bias         | 0°C to 70°C     |
| Storage Temperature            | -65°C to +150°C |
| All Output and Supply Voltages | -0.5V to +7V    |
| All Input Voltages             | -1.0V to +5.5V  |
| Output Currents                | 125 mA          |

\*COMMENT: Stresses above those listed under "Absolute Maximum Rating" may cause permanent damage to the device. This is a stress rating only and functional operation of the device at these or at any other condition above those indicated in the operational sections of this specification is not implied.

$T_A = 0^\circ\text{C}$  to  $+70^\circ\text{C}$ ,  $V_{CC} = +5V \pm 5\%$

| Symbol     | Parameter   | Limits |       |           | Unit          | Conditions   |
|------------|---|--------|-------|-----------|---------------|--|
|            |   | Min.   | Typ.  | Max.      |               |  |
| $I_{F1}$   | Input Load Current $\overline{DI}, \overline{EN}, \overline{CS}$    |        | -0.15 | -.5       | mA            | $V_F = 0.45$   |
| $I_{F2}$   | Input Load Current All Other Inputs                                 |        | -0.08 | -.25      | mA            | $V_F = 0.45$   |
| $I_{R1}$   | Input Leakage Current $\overline{DI}, \overline{EN}, \overline{CS}$ |        |       | 20        | $\mu\text{A}$ | $V_R = 5.25\text{V}$   |
| $I_{R2}$   | Input Leakage Current DI Inputs                                     |        |       | 10        | $\mu\text{A}$ | $V_R = 5.25\text{V}$   |
| $V_C$      | Input Forward Voltage Clamp   |        |       | -1        | V             | $I_C = -5\text{mA}$  |
| $V_{IL}$   | Input "Low" Voltage   |        |       | .95       | V             |  |
| $V_{IH}$   | Input "High" Voltage  | 2.0    |       |           | V             |  |
| $ I_{OL} $ | Output Leakage Current (3-State)                                    |        |       | 20<br>100 | $\mu\text{A}$ | $V_O = 0.45\text{V}/5.25\text{V}$                                      |
| $I_{CC}$   | Power Supply Current  | 8216   | 95    | 130       | mA            |  |
|            |   | 8226   | 85    | 120       | mA            |  |
| $V_{OL1}$  | Output "Low" Voltage  |        | 0.3   | .45       | V             | DO Outputs $I_{OL} = 15\text{mA}$<br>DB Outputs $I_{OL} = 25\text{mA}$ |
| $V_{OL2}$  | Output "Low" Voltage  | 8216   | 0.5   | .6        | V             | DB Outputs $I_{OL} = 55\text{mA}$                                      |
|            |   | 8226   | 0.5   | .6        | V             | DB Outputs $I_{OL} = 50\text{mA}$                                      |
| $V_{OH1}$  | Output "High" Voltage   | 3.65   | 4.0   |           | V             | DO Outputs $I_{OH} = -1\text{mA}$                                      |
| $V_{OH2}$  | Output "High" Voltage   | 2.4    | 3.0   |           | V             | DB Outputs $I_{OH} = -10\text{mA}$                                     |
| $I_{OS}$   | Output Short Circuit Current  |        | -15   | -35       | mA            | DO Outputs $V_O \cong 0\text{V}$ ,                                     |
|            |   |        | -30   | -75       | mA            | DB Outputs $V_{CC} = 5.0\text{V}$                                      |

NOTE: Typical values are for  $T_A = 25^\circ\text{C}$ ,  $V_{CC} = 5.0\text{V}$ .

WAVEFORMS

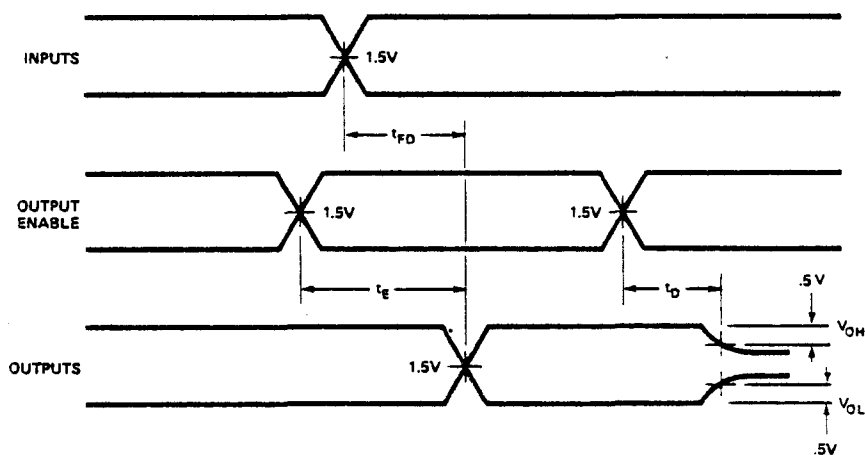

A.C. CHARACTERISTICS

$T_A = 0^\circ C$  to  $+70^\circ C$ ,  $V_{CC} = +5V \pm 5\%$

| Symbol    | Parameter                        | Limits |         |      | Unit | Conditions  |
|-----------|----------------------------------|--------|---------|------|------|---|
|           |                                  | Min.   | Typ.[1] | Max. |      |   |
| $T_{PD1}$ | Input to Output Delay DO Outputs |        | 15      | 25   | ns   | $C_L = 30pF$ , $R_1 = 300\Omega$<br>$R_2 = 600\Omega$ |
| $T_{PD2}$ | Input to Output Delay DB Outputs |        | 20      | 30   | ns   | $C_L = 300pF$ , $R_1 = 90\Omega$                      |
|           |                                  |        | 16      | 25   | ns   | $R_2 = 180\Omega$                                     |
| $T_E$     | Output Enable Time               |        | 45      | 65   | ns   | (Note 2)  |
|           |                                  |        | 35      | 54   | ns   | (Note 3)  |
| $T_D$     | Output Disable Time              |        | 20      | 35   | ns   | (Note 4)  |

TEST CONDITIONS:

Input pulse amplitude of 2.5V.  
 Input rise and fall times of 5 ns between 1 and 2 volts.  
 Output loading is 5 mA and 10 pF.  
 Speed measurements are made at 1.5 volt levels.

TEST LOAD CIRCUIT

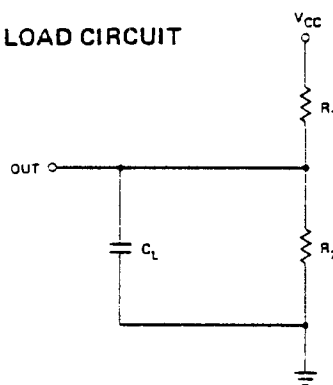

Capacitance<sup>[5]</sup>

| Symbol     | Parameter          | Limits |         |      | Unit |
|------------|--------------------|--------|---------|------|------|
|            |                    | Min.   | Typ.[1] | Max. |      |
| $C_{IN}$   | Input Capacitance  |        | 4       | 8    | pF   |
| $C_{OUT1}$ | Output Capacitance |        | 6       | 10   | pF   |
| $C_{OUT2}$ | Output Capacitance |        | 13      | 18   | pF   |

TEST CONDITIONS:  $V_{BIAS} = 2.5V$ ,  $V_{CC} = 5.0V$ ,  $T_A = 25^\circ C$ ,  $f = 1$  MHz.

- NOTES:
1. Typical values are for  $T_A = 25^\circ C$ ,  $V_{CC} = 5.0V$ .
  2. DO Outputs,  $C_L = 30pF$ ,  $R_1 = 300/10$  K $\Omega$ ,  $R_2 = 180/1$  K $\Omega$ ; DB Outputs,  $C_L = 300pF$ ,  $R_1 = 90/10$  K $\Omega$ ,  $R_2 = 180/1$  K $\Omega$ .
  3. DO Outputs,  $C_L = 30pF$ ,  $R_1 = 300/10$  K $\Omega$ ,  $R_2 = 600/1$  K $\Omega$ ; DB Outputs,  $C_L = 300pF$ ,  $R_1 = 90/10$  K $\Omega$ ,  $R_2 = 180/1$  K $\Omega$ .
  4. DO Outputs,  $C_L = 5pF$ ,  $R_1 = 300/10$  K $\Omega$ ,  $R_2 = 600/1$  K $\Omega$ ; DB Outputs,  $C_L = 5pF$ ,  $R_1 = 90/10$  K $\Omega$ ,  $R_2 = 180/1$  K $\Omega$ .
  5. This parameter is periodically sampled and not 100% tested.



# Schottky Bipolar 8224

## CLOCK GENERATOR AND DRIVER FOR 8080A CPU

- Single Chip Clock Generator/Driver for 8080A CPU
- Power-Up Reset for CPU
- Ready Synchronizing Flip-Flop
- Advanced Status Strobe
- Oscillator Output for External System Timing
- Crystal Controlled for Stable System Operation
- Reduces System Package Count

The 8224 is a single chip clock generator/driver for the 8080A CPU. It is controlled by a crystal, selected by the designer, to meet a variety of system speed requirements.

Also included are circuits to provide power-up reset, advance status strobe and synchronization of ready.

The 8224 provides the designer with a significant reduction of packages used to generate clocks and timing for 8080A.

PIN CONFIGURATION

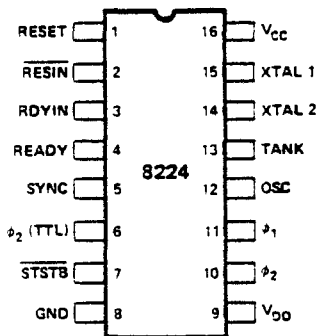

BLOCK DIAGRAM

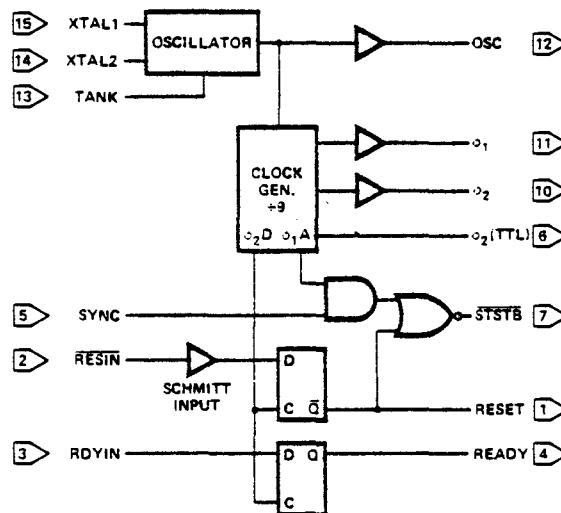

PIN NAMES

|       |                         |
|-------|-------------------------|
| RESIN | RESET INPUT             |
| RESET | RESET OUTPUT            |
| RDYIN | READY INPUT             |
| READY | READY OUTPUT            |
| SYNC  | SYNC INPUT              |
| STSTB | STATUS STB (ACTIVE LOW) |
| phi_1 | 8080                    |
| phi_2 | CLOCKS                  |

|             |                         |
|-------------|-------------------------|
| XTAL 1      | CONNECTIONS FOR CRYSTAL |
| XTAL 2      |                         |
| TANK        | USED WITH OVERTONE XTAL |
| OSC         | OSCILLATOR OUTPUT       |
| phi_2 (TTL) | phi_2 CLK (TTL LEVEL)   |
| VCC         | +5V                     |
| VDD         | +12V                    |
| GND         | 0V                      |

## FUNCTIONAL DESCRIPTION

### General

The 8224 is a single chip Clock Generator/Driver for the 8080A CPU. It contains a crystal-controlled oscillator, a "divide by nine" counter, two high-level drivers and several auxiliary logic functions.

### Oscillator

The oscillator circuit derives its basic operating frequency from an external, series resonant, fundamental mode crystal. Two inputs are provided for the crystal connections (XTAL1, XTAL2).

The selection of the external crystal frequency depends mainly on the speed at which the 8080A is to be run at. Basically, the oscillator operates at 9 times the desired processor speed.

A simple formula to guide the crystal selection is:

$$\text{Crystal Frequency} = \frac{1}{t_{CY}} \text{ times } 9$$

Example 1: (500ns  $t_{CY}$ )  
2mHz times 9 = 18mHz\*

Example 2: (800ns  $t_{CY}$ )  
1.25mHz times 9 = 11.25mHz

Another input to the oscillator is TANK. This input allows the use of overtone mode crystals. This type of crystal generally has much lower "gain" than the fundamental type so an external LC network is necessary to provide the additional "gain" for proper oscillator operation. The external LC network is connected to the TANK input and is AC coupled to ground. See Figure 4.

The formula for the LC network is:

$$F = \frac{1}{2\pi \sqrt{LC}}$$

The output of the oscillator is buffered and brought out on OSC (pin 12) so that other system timing signals can be derived from this stable, crystal-controlled source.

\*When using crystals above 10mHz a small amount of frequency "trimming" may be necessary to produce the exact desired frequency. The addition of a small selected capacitance (3pF - 10pF) in series with the crystal will accomplish this function.

### Clock Generator

The Clock Generator consists of a synchronous "divide by nine" counter and the associated decode gating to create the waveforms of the two 8080A clocks and auxiliary timing signals.

The waveforms generated by the decode gating follow a simple 2-5-2 digital pattern. See Figure 2. The clocks generated; phase 1 and phase 2, can best be thought of as consisting of "units" based on the oscillator frequency. Assume that one "unit" equals the period of the oscillator frequency. By multiplying the number of "units" that are contained in a pulse width or delay, times the period of the oscillator frequency, the approximate time in nanoseconds can be derived.

The outputs of the clock generator are connected to two high level drivers for direct interface to the 8080A CPU. A TTL level phase 2 is also brought out  $\phi_2$  (TTL) for external timing purposes. It is especially useful in DMA dependant activities. This signal is used to gate the requesting device on to the bus once the 8080A CPU issues the Hold Acknowledgement (HLDA).

Several other signals are also generated internally so that optimum timing of the auxiliary flip-flops and status strobe (STSTB) is achieved.

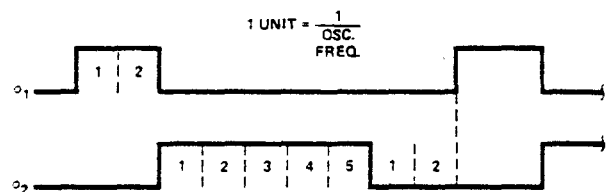
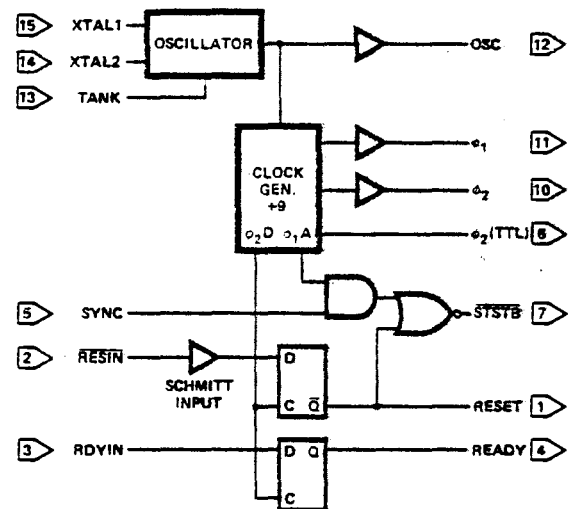

EXAMPLE: (8080  $t_{CY}$  = 500ns)  
OSC = 18mHz/55ns  
 $\phi_1$  = 110ns (2 x 55ns)  
 $\phi_2$  = 275ns (5 x 55ns)  
 $\phi_2 - \phi_1$  = 110ns (2 x 55ns)

# SCHOTTKY BIPOLAR 8224

## STSTB (Status Strobe)

At the beginning of each machine cycle the 8080A CPU issues status information on its data bus. This information tells what type of action will take place during that machine cycle. By bringing in the SYNC signal from the CPU, and gating it with an internal timing signal ( $\phi_1A$ ), an active low strobe can be derived that occurs at the start of each machine cycle at the earliest possible moment that status data is stable on the bus. The  $\overline{STSTB}$  signal connects directly to the 8228 System Controller.

The power-on Reset also generates  $\overline{STSTB}$ , but of course, for a longer period of time. This feature allows the 8228 to be automatically reset without additional pins devoted for this function.

## Power-On Reset and Ready Flip-Flops

A common function in 8080A Microcomputer systems is the generation of an automatic system reset and start-up upon initial power-on. The 8224 has a built in feature to accomplish this feature.

An external RC network is connected to the  $\overline{RESIN}$  input. The slow transition of the power supply rise is sensed by an internal Schmitt Trigger. This circuit converts the slow transition into a clean, fast edge when its input level reaches a predetermined value. The output of the Schmitt Trigger is connected to a "D" type flip-flop that is clocked with  $\phi_2D$  (an internal timing signal). The flip-flop is synchronously reset and an active high level that complies with the 8080A input spec is generated. For manual switch type system Reset circuits, an active low switch closing can be connected to the  $\overline{RESIN}$  input in addition to the power-on RC network.

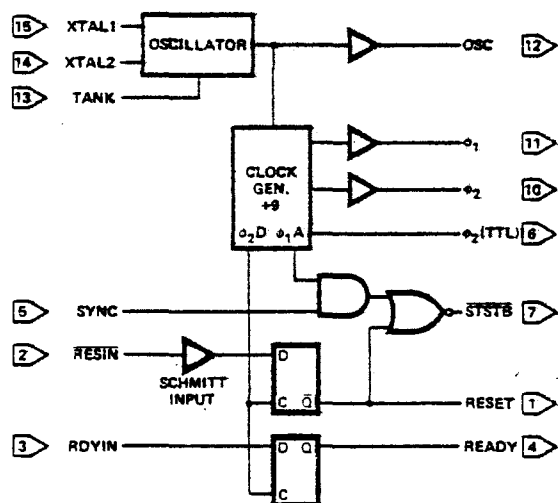

The READY input to the 8080A CPU has certain timing specifications such as "set-up and hold" thus, an external synchronizing flip-flop is required. The 8224 has this feature built-in. The RDYIN input presents the asynchronous "wait request" to the "D" type flip-flop. By clocking the flip-flop with  $\phi_2D$ , a synchronized READY signal at the correct input level, can be connected directly to the 8080A.

The reason for requiring an external flip-flop to synchronize the "wait request" rather than internally in the 8080 CPU is that due to the relatively long delays of MOS logic such an implementation would "rob" the designer of about 200ns during the time his logic is determining if a "wait" is necessary. An external bipolar circuit built into the clock generator eliminates most of this delay and has no effect on component count.

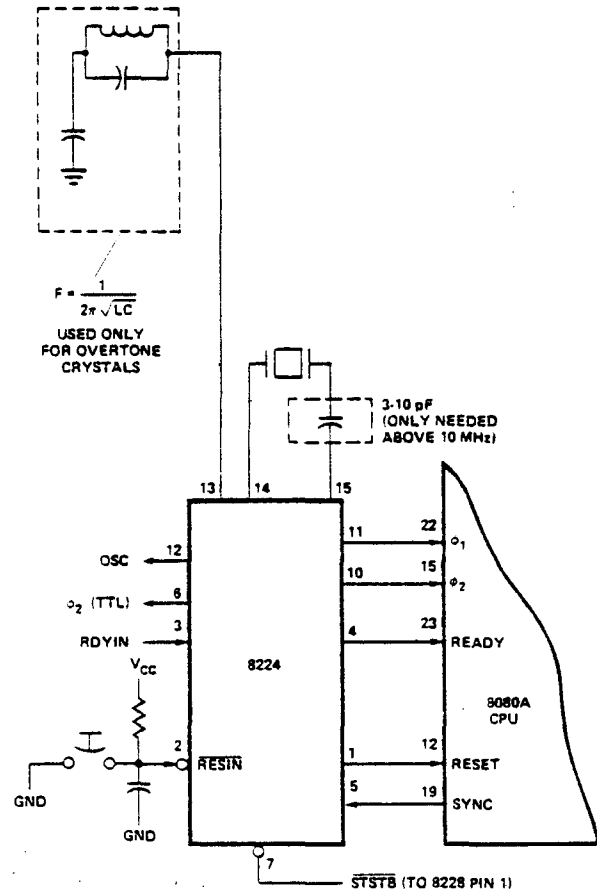



# SCHOTTKY BIPOLAR 8224

## D.C. Characteristics

$T_A = 0^\circ\text{C}$  to  $70^\circ\text{C}$ ;  $V_{CC} = +5.0\text{V} \pm 5\%$ ;  $V_{DD} = +12\text{V} \pm 5\%$ .

| Symbol          | Parameter  | Limits     |      |       | Units         | Test Conditions  |
|-----------------|--|------------|------|-------|---------------|--|
|                 |  | Min.       | Typ. | Max.  |               |  |
| $I_F$           | Input Current Loading  |            |      | -0.25 | mA            | $V_F = .45\text{V}$  |
| $I_R$           | Input Leakage Current  |            |      | 10    | $\mu\text{A}$ | $V_R = 5.25\text{V}$   |
| $V_C$           | Input Forward Clamp Voltage                                    |            |      | 1.0   | V             | $I_C = -5\text{mA}$  |
| $V_{IL}$        | Input "Low" Voltage  |            |      | .8    | V             | $V_{CC} = 5.0\text{V}$   |
| $V_{IH}$        | Input "High" Voltage   | 2.6<br>2.0 |      |       | V             | Reset Input<br>All Other Inputs  |
| $V_{IH}-V_{IL}$ | REDIN Input Hysteresis   | .25        |      |       | mV            | $V_{CC} = 5.0\text{V}$   |
| $V_{OL}$        | Output "Low" Voltage   |            |      | .45   | V             | $(\phi_1, \phi_2)$ , Ready, Reset, $\overline{\text{STSTB}}$<br>$I_{OL} = 2.5\text{mA}$<br>All Other Outputs<br>$I_{OL} = 15\text{mA}$ |
|                 |  |            |      | .45   | V             |  |
| $V_{OH}$        | Output "High" Voltage  |            |      |       |               |  |
|                 | $\phi_1, \phi_2$   | 9.4        |      |       | V             | $I_{OH} = -100\mu\text{A}$   |
|                 | READY, RESET   | 3.6        |      |       | V             | $I_{OH} = -100\mu\text{A}$   |
|                 | All Other Outputs  | 2.4        |      |       | V             | $I_{OH} = -1\text{mA}$   |
| $I_{SC}^{[1]}$  | Output Short Circuit Current<br>(All Low Voltage Outputs Only) | -10        |      | -60   | mA            | $V_O = 0\text{V}$<br>$V_{CC} = 5.0\text{V}$  |
| $I_{CC}$        | Power Supply Current   |            |      | 115   | mA            |  |
| $I_{DD}$        | Power Supply Current   |            |      | 12    | mA            |  |

Note: 1. Caution,  $\phi_1$  and  $\phi_2$  output drivers do not have short circuit protection

## CRYSTAL REQUIREMENTS

Tolerance: .005% at  $0^\circ\text{C}$  -  $70^\circ\text{C}$

Resonance: Series (Fundamental)\*

Load Capacitance: 20-35pF

Equivalent Resistance: 75-20 ohms

Power Dissipation (Min): 4mW

\*With tank circuit use 3rd overtone mode.

# SCHOTTKY BIPOLAR 8224

## A.C. Characteristics

$V_{CC} = +5.0V \pm 5\%$ ;  $V_{DD} = +12.0V \pm 5\%$ ;  $T_A = 0^\circ C$  to  $70^\circ C$

| Symbol        | Parameter                                | Limits                     |                    |                            | Units | Test Conditions  |
|---------------|--|----------------------------|--------------------|----------------------------|-------|--|
|               |  | Min.                       | Typ.               | Max.                       |       |  |
| $t_{\phi 1}$  | $\phi_1$ Pulse Width                     | $\frac{2t_{cy}}{9} - 20ns$ |                    |                            | ns    | $C_L = 20pF$ to $50pF$   |
| $t_{\phi 2}$  | $\phi_2$ Pulse Width                     | $\frac{5t_{cy}}{9} - 35ns$ |                    |                            |       |  |
| $t_{D1}$      | $\phi_1$ to $\phi_2$ Delay               | 0                          |                    |                            |       |  |
| $t_{D2}$      | $\phi_2$ to $\phi_1$ Delay               | $\frac{2t_{cy}}{9} - 14ns$ |                    |                            |       |  |
| $t_{D3}$      | $\phi_1$ to $\phi_2$ Delay               | $\frac{2t_{cy}}{9}$        |                    | $\frac{2t_{cy}}{9} + 20ns$ |       |  |
| $t_R$         | $\phi_1$ and $\phi_2$ Rise Time          |                            |                    | 20                         |       |  |
| $t_F$         | $\phi_1$ and $\phi_2$ Fall Time          |                            |                    | 20                         |       |  |
| $t_{D\phi 2}$ | $\phi_2$ to $\phi_2$ (TTL) Delay         | -5                         |                    | +15                        | ns    | $\phi_2$ TTL, $C_L=30$<br>$R_1=300\Omega$<br>$R_2=600\Omega$   |
| $t_{DSS}$     | $\phi_2$ to $\overline{STSTB}$ Delay     | $\frac{6t_{cy}}{9} - 30ns$ |                    | $\frac{6t_{cy}}{9}$        |       | $\overline{STSTB}$ , $C_L=15pF$<br>$R_1 = 2K$<br>$R_2 = 4K$    |
| $t_{PW}$      | $\overline{STSTB}$ Pulse Width           | $\frac{t_{cy}}{9} - 15ns$  |                    |                            |       |  |
| $t_{DRS}$     | RDYIN Setup Time to Status Strobe        | $50ns - \frac{4t_{cy}}{9}$ |                    |                            |       |  |
| $t_{DRH}$     | RDYIN Hold Time After $\overline{STSTB}$ | $\frac{4t_{cy}}{9}$        |                    |                            |       |  |
| $t_{DR}$      | RDYIN or RESIN to $\phi_2$ Delay         | $\frac{4t_{cy}}{9} - 25ns$ |                    |                            |       | Ready & Reset<br>$C_L=10pF$<br>$R_1=2K$<br>$R_2=4K$            |
| $t_{CLK}$     | CLK Period                               |                            | $\frac{t_{cy}}{9}$ |                            |       |  |
| $f_{max}$     | Maximum Oscillating Frequency            | 27                         |                    |                            | MHz   |  |
| $C_m$         | Input Capacitance                        |                            |                    | 8                          | pF    | $V_{CC}=+5.0V$<br>$V_{DD}=+12V$<br>$V_{BIAS}=2.5V$<br>$f=1MHz$ |

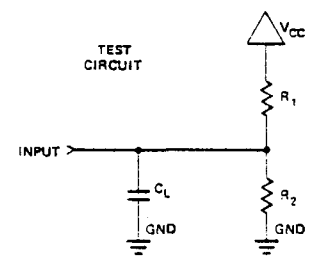

# SCHOTTKY BIPOLAR 8224

## WAVEFORMS

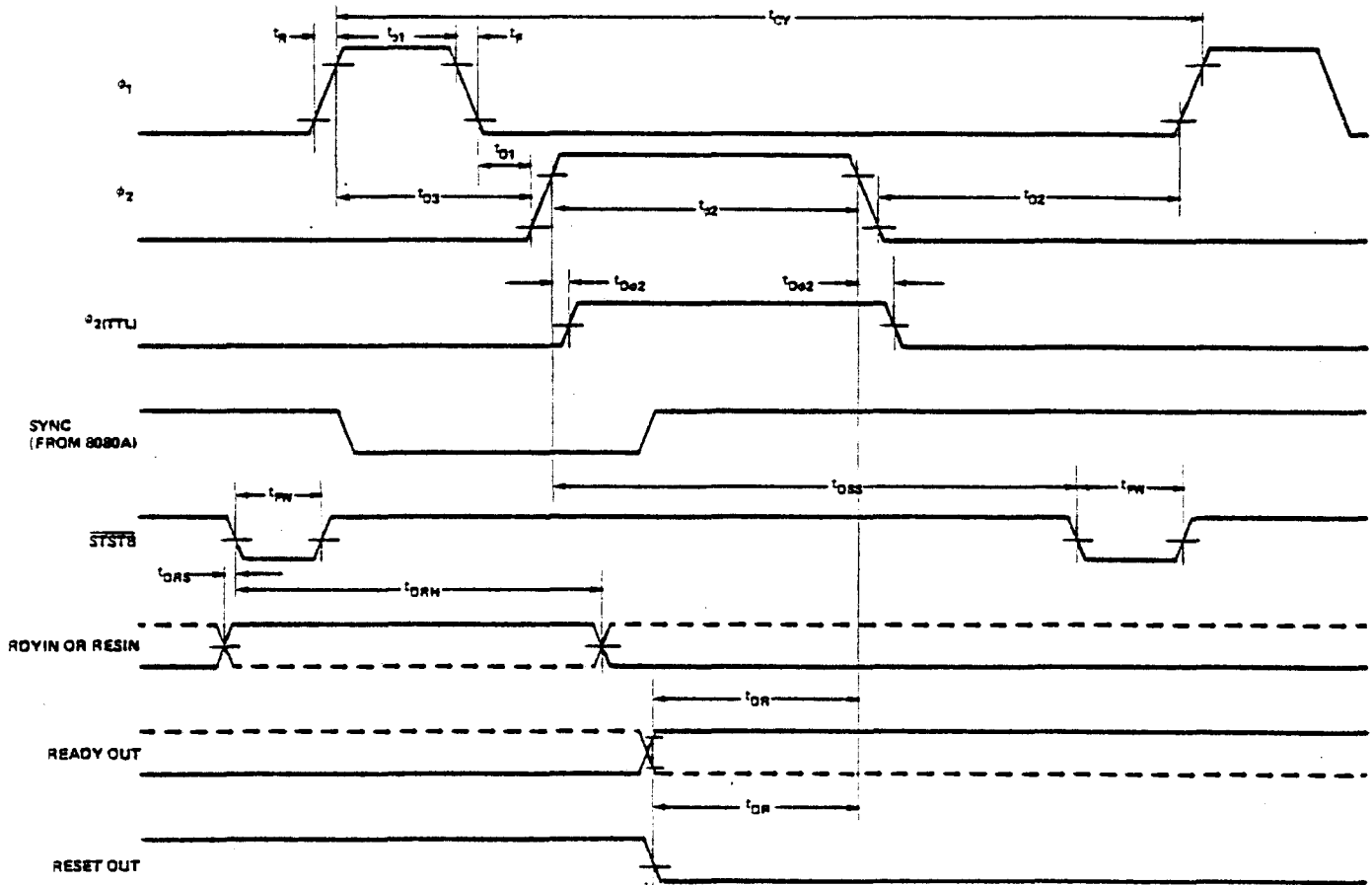

VOLTAGE MEASUREMENT POINTS:  $\phi_1, \phi_2$  Logic "0" = 1.0V, Logic "1" = 8.0V. All other signals measured at 1.5V.

### EXAMPLE:

A.C. Characteristics (For  $t_{CY} = 488.28$  ns)

$T_A = 0^\circ\text{C}$  to  $70^\circ\text{C}$ ;  $V_{DD} = +5V \pm 5\%$ ;  $V_{DD} = +12V \pm 5\%$ .

| Symbol        | Parameter                                | Limits |      |        | Units | Test Conditions   |
|---------------|--|--------|------|--------|-------|---|
|               |  | Min.   | Typ. | Max.   |       |   |
| $t_{p1}$      | $\phi_1$ Pulse Width                     | 99     |      |        | ns    | $t_{CY} = 488.28$ ns<br>$\phi_1$ & $\phi_2$ Loaded to $C_L = 20$ to $50$ pF   |
| $t_{p2}$      | $\phi_2$ Pulse Width                     | 236    |      |        | ns    |   |
| $t_{D1}$      | Delay $\phi_1$ to $\phi_2$               | 0      |      |        | ns    |   |
| $t_{D2}$      | Delay $\phi_2$ to $\phi_1$               | 95     |      |        | ns    |   |
| $t_{D3}$      | Delay $\phi_1$ to $\phi_2$ Leading Edges | 109    |      | 129    | ns    |   |
| $t_r$         | Output Rise Time                         |        |      | 20     | ns    |   |
| $t_f$         | Output Fall Time                         |        |      | 20     | ns    |   |
| $t_{DSS}$     | $\phi_2$ to $\overline{STSTB}$ Delay     | 296    |      | 326    | ns    | Ready & Reset Loaded to $2\text{mA}/10\text{pF}$<br>All measurements referenced to 1.5V unless specified otherwise. |
| $t_{D\phi 2}$ | $\phi_2$ to $\phi_2$ (TTL) Delay         | -5     |      | +15    | ns    |   |
| $t_{PW}$      | Status Strobe Pulse Width                | 40     |      |        | ns    |   |
| $t_{ORS}$     | RDYIN Setup Time to $\overline{STSTB}$   | -167   |      |        | ns    |   |
| $t_{ORH}$     | RDYIN Hold Time after $\overline{STSTB}$ | 217    |      |        | ns    |   |
| $t_{OR}$      | READY or RESET to $\phi_2$ Delay         | 192    |      |        | ns    |   |
| $f_{MAX}$     | Oscillator Frequency                     |        |      | 18.432 | MHz   |   |

#### 3-4. SCHEMATIC REFERENCING

The detailed schematics of the Interface circuit, CPU circuit, and Display/Control panel are provided to aid in determining signal direction and tracing. A solid arrow (→) on the signal line indicates direction, and the tracing of the signal through the schematics is referenced as it leaves the page. The reference is shown as a number - letter number (e.g. 2-A3), indicating sheet 2 and schematic zone A3. The reference may be shown alone or in a bracket. If the reference is bracketed, the signal is going to another schematic which is referenced outside the bracket. If the reference is shown alone, the signal is going to another page of the multisheet schematic.

#### 3-5. 8800b BLOCK DIAGRAM DESCRIPTION (Figure 3-1)

The 8800b computer contains four basic circuits; the Central Processing Unit (CPU), Memory, an Input/Output (I/O) section, and the Front Panel. The CPU controls the interpretation and execution of software instructions, and Memory stores the software information to be used by the CPU. The I/O section provides a communication link between the CPU and external devices. The Front Panel allows the operator to manually perform various operations with the 8800b. The 8800b basic block diagram and accompanying text (paragraphs 3-6 and 3-7) explain the CPU's communication with the memory (and I/O) circuits and with the front panel. The system clock, power-on operation and run operation are explained in paragraphs 3-8 through 3-10.

#### 3-6. CPU TO MEMORY OR I/O OPERATION

The Memory or I/O section operation requires several signals that allow transfer of data to and from the CPU. The ADDRESS bus (A0-A15) consists of sixteen individual lines from the CPU to Memory and I/O devices. The signals on this bus represent a particular

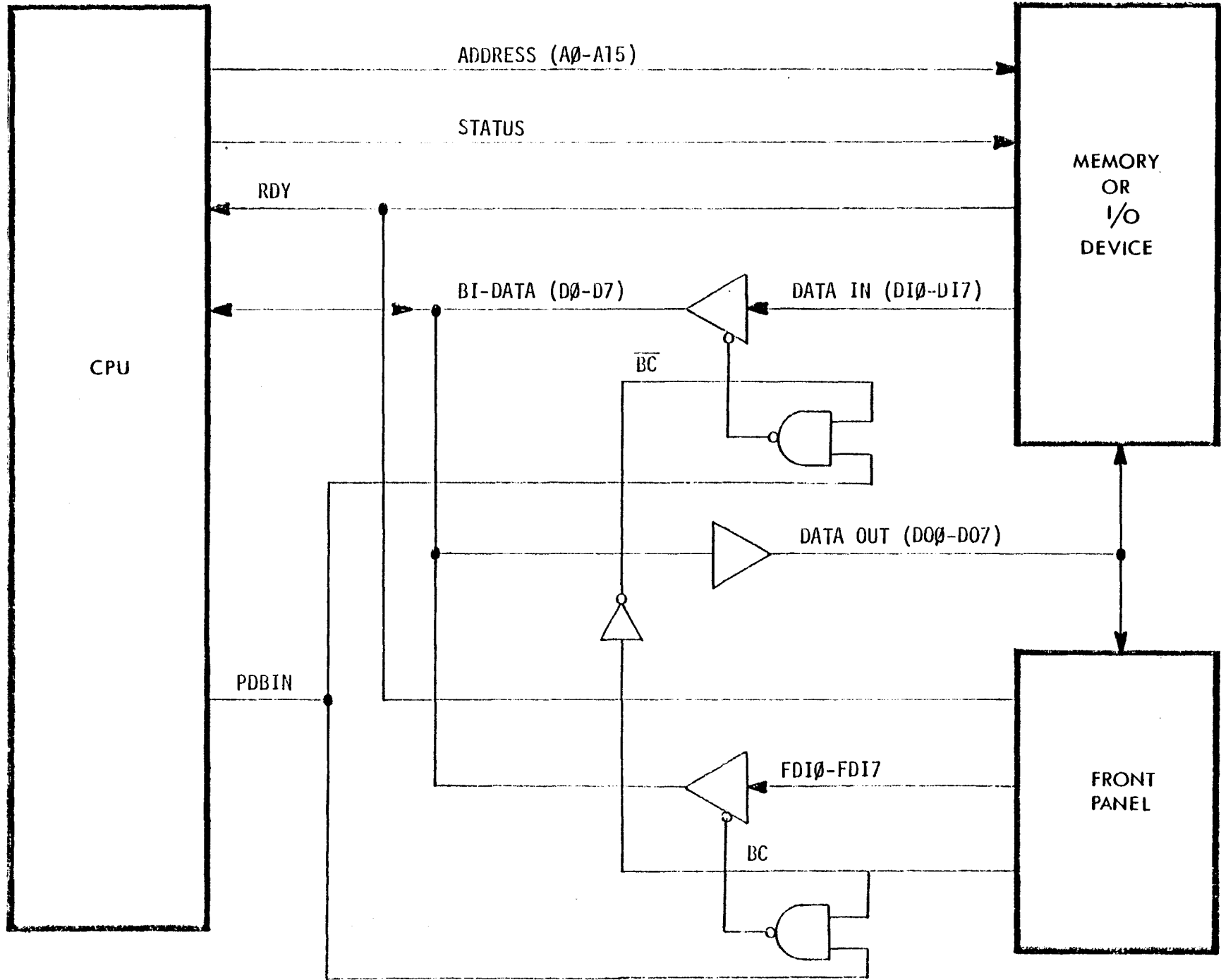

Figure 3-1. 8800b Basic Block.

memory address location or external device number that is needed to establish communications with Memory or I/O devices. Once the address data (A0-A15) is presented to Memory or I/O devices, the CPU generates various STATUS signals. The STATUS signals enable decoding of a memory address or conditions the I/O device card to send or receive data from the CPU

Data from Memory or I/O devices is presented on the DATA IN lines (DI0-DI7) and applied to eight non-inverting bus drivers. The drivers are enabled by a PDBIN signal from the CPU and a  $\overline{BC}$  (bus control) signal. The BC signal is LOW when the Front Panel is not in operation. The eight non-inverting bus drivers, when enabled, present the input data to BI-DATA lines (D0-D7) which input the data to the CPU.

Data outputted to Memory or I/O devices is presented to the DATA OUT lines (DO0-DO7) from the CPU. The RDY (ready) line either forces the CPU to a wait state while data is being transferred or allows the CPU to process data.

### 3-7. FRONT PANEL OPERATION

The Front Panel Operation is very similar to Memory or I/O section operation. The Front Panel gains control of the CPU by producing a HIGH BC signal. The BC signal disables the DATA IN (DI0-DI7) lines from a Memory or I/O Device and enables the FDI0-FDI7 lines. The FDI0-FDI7 lines contain Front Panel data which is transferred to the CPU upon the occurrence of the PDBIN signal. All data from the CPU to the Front Panel is applied to the DATA OUT (DO0-DO7) lines and displayed on the Front Panel.

### 3-8. SYSTEM CLOCK

The system clock (F) for the 8800b is located on the CPU circuit card (Figure 3-14, zone B7). The system clock generates phase 1 and phase 2 outputs derived from the external crystal (XTAL 1). The 01 and 02 outputs operate at a frequency of 2 MHz, which determines the speed at which the 8080 (M) will operate. The 01 and 02 clock signals are presented to the bus (zone A7) through inverter A and inverter bus driver J, respectively. The 01 clock is used by memory and external I/O cards, and the 02 clock is applied to the 24-bit counter on the Display/Control card (Figure

3-16, sheet 1, zone D2) through the Interface card (Figure 3-15, sheet 2, zone B3).

### 3-9. POWER ON CLEAR OPERATION

Positioning the ON/OFF switch to ON causes a power on clear (POC) operation to be performed, resetting the 8800b circuitry. The POC signal is generated on the CPU card (Figure 3-14, zone A3) when VCC is applied. With VCC present, capacitor C4 will charge to the VCC potential in 100 milliseconds because of the RC time constant of C4 and resistor R17. The 100 millisecond delay disables (turns off) transistor Q3, producing a LOW  $\overline{POC}$  signal to the bus (pin 99) through inverters S and J (zone A2). The  $\overline{POC}$  signal is inverted by U on the Interface card (Figure 3-15, sheet 2, zone B2) and presented to the Display/Control card as a HIGH POC signal (Figure 3-16, sheet 2, zone D6). The POC input is inverted LOW by T1 (zone C6) and applied to three circuits on the Display/Control Card. It clears the M1 flip-flops (zone C7) through NOR gate T1 and inverter J1 (zone C6), insuring that single step operation is disabled. It presets the M1 flip-flop (zone C9) and disables NAND gate P1 (zone B8) to insure that the 8800b is not running. The  $\overline{POC}$  signal (zone D9) is also present at NOR gate R1 which inverts it HIGH to reset the PROM counter. The  $\overline{POC}$  signal is present to the external input/output (I/O) cards and memory for similar initialization operations. During the POC operation, two other functions are being performed.

On the Display/Control card (Figure 3-16, sheet 1, zone D2), a 24-bit counter is being clocked by  $\emptyset 2$  which will condition circuits on the Display/Control card. The  $\overline{CT3}$  output (zone D1) from the counter is applied to the clock (CK) input of quad latches C1, F1, H1, G1, N1, U1, Y1, and W1 (zones B9-B1) through non-inverting bus driver K1 (zones A1 and D1) and inverter J1 (zone C1). The  $\overline{CT3}$  signal clears the quad latches in the following manner to insure all latches are conditioned after POC. The inputs to quad latches C1, F1, H1, and G1 are HIGH because no switches are activated. After the first  $\overline{CT3}$  clock, all the  $\overline{Q}$  outputs are LOW and applied to the inputs of quad latches N1, U1, Y1, and W1 (zones B9-B1).

The occurrence of the next  $\overline{C13}$  clock latches the Q outputs LOW and the  $\overline{Q}$  outputs HIGH during the POC operation.

When VCC is present in the CPU circuits, another RC time constant affects the clock generator F (Figure 3-14, zone B7). Capacitor C2 will charge to the VCC potential in 33 microseconds which is the time constant of C2 and resistor R10. The 33 microsecond delay allows the RESET output from F (zone B7) to clear the 8080 M internal circuits. The 8080 remains in this state because the READY output (zone B7) is LOW from F. The READY output from F will be affected during the run operation.

### 3-10. RUN OPERATION

The Run Operation allows the 8080 on the CPU Board to start processing data to and from memory and external devices. The Run Operation is activated when the RUN/STOP switch on the 8800b front panel is momentarily depressed to RUN.

The RUN/STOP circuits are located on the Display/Control card (Figure 3-16, sheet 2, zone A9). When the RUN/STOP switch is momentarily depressed, a LOW is applied to quad latch C1, input D2. The occurrence of the next C13 clock (zone A1) causes the  $\overline{Q}$  output at pin 6 of C1 (zone B9) to go HIGH. This HIGH is applied to quad latch N1, input D2. The next C13 clock causes the Q output at pin 2 of N1 (zone B9) to go HIGH and allows NAND gate P1 to clear M1 (zone C9). The Q output of M1 generates a LOW  $\overline{RUN}$  signal and LOW  $\overline{FRDY}$  signal through NOR gate P1 and inverter R1 (zone D9).

The  $\overline{RUN}$  signal is applied to the Interface Card (Figure 3-15, sheet 2, zone D2) to condition the MD input of data latch G (sheet 3, zone A6). With MD enabled, output data from the CPU can be displayed on the 8800b front panel if a STB input is present to G (discussed in Paragraph 3-40).

The  $\overline{FRDY}$  signal is applied to the Interface Card (Figure 3-15, sheet 2) to allow the 8080 to start processing data. The FRDY output is applied to pin 58 of the bus through inverter R and non-inverting bus driver H as a HIGH (zone A1). The HIGH on pin 58 of the bus enables NAND gate C, pin 8, LOW on the CPU (Figure 3-14, zone A7) which is inverted HIGH by B (zone B7) and applied



to the clock generator F RYDIN input. The RYDIN signal enables the READY output at F HIGH (zone B7) which allows the 8080 M (zone A8) to start processing data.

### 3-11. 8800b DATA PROCESSING OPERATION

The 8800b data processing begins when the 8080 IC is enabled (Paragraph 3-10). With the 8080 IC enabled, the program (P) counter in the 8080 starts to increment or begins at a predetermined count established by the operator. The count in the P counter represents a location in memory which is examined by the CPU before the P counter increments to the next location. To examine each memory location, the CPU initiates an instruction cycle operation. Every instruction cycle consists of one, two, three, four, or five machine cycles. In order to perform a data processing operation, basic machine cycles are required.

The Instruction Fetch Machine cycle is a basic machine cycle needed to allow the CPU to fetch an instruction from memory. A memory read machine cycle is also a basic machine cycle that enables the CPU to communicate with a memory or external device for data transfer operations.

The following paragraphs discuss data transfers from an external device to the CPU, from the CPU to memory, from memory to the CPU, and from the CPU to an external device. However, the instruction fetch and memory read machine cycles used in the data transfers are discussed first because their operation is identical in all of the data transfers. It is important to note that there are many variations of data transfer which are dependent on the programmer.

### 3-12. INSTRUCTION FETCH CYCLE

The Instruction Fetch Cycle is the first machine cycle (M1) to be performed by the CPU in any data transfer operation. The memory location specified by the P counter contains data that the CPU interprets as an instruction. The first cycle must be a fetch cycle because, during the fetch cycle, the CPU is informed as to what operation will be performed next.

### 3-13. INSTRUCTION FETCH CYCLE OPERATION (Figure 3-2)

The Instruction Fetch Cycle is initiated whenever the P counter is incremented to a new memory address location (e.g. 000 100<sub>g</sub>) where an instruction (e.g. 072<sub>g</sub>) is stored. In order to fetch the 072<sub>g</sub> data from memory during machine cycle one, several signals are generated by the CPU.

A PSYNC output from the CPU is applied to memory to condition for address decoding. Next the ADDRESS (000 100<sub>g</sub>), consisting of sixteen parallel outputs (A<sub>0</sub>-A<sub>15</sub>) from the CPU, is presented to the Display/Control Card and memory. The A<sub>0</sub> through A<sub>15</sub> signals drive the appropriate address buffers, illuminating the light emitting diodes (LEDs) on the Display/Control Card. The ADDRESS and PSYNC signals present at the memory from the CPU initiate decoding of the memory address (000 100<sub>g</sub>).

The CPU then generates three signals, SM1, S<sub>MEMR</sub>, and  $\emptyset$ 1 CLOCK to complete the Instruction Fetch Cycle. The SM1 output is applied to the Display/Control Card through the Interface Card to light the M1 (machine cycle 1) LED on the 8800b front panel. The S<sub>MEMR</sub> and  $\emptyset$ 1 CLOCK outputs are applied to memory to allow decoding of the memory address (000 100<sub>g</sub>). With the memory address decoded, the 072<sub>g</sub> data present in that location is transferred to the CPU on the eight DATA IN (DI<sub>0</sub>-DI<sub>7</sub>) lines. The DIG 1 input to the CPU from the Interface Card is enabled when the 8800b is in the run mode (see paragraph 3-10). This permits the memory data to be transferred to the CPU. The S<sub>MEMR</sub> output is applied to the Display/Control Card through the Interface Card to light the MEMR (memory read) LED on the 8800b front panel. This operation is performed when the P counter is incremented, indicating a new memory address.

### 3-14. INSTRUCTION FETCH CYCLE DETAILED OPERATION

The following paragraphs describe the Instruction Fetch Cycle operation in detail. Refer to Figure 3-3, Instruction Fetch Cycle Timing, during the explanation. The Instruction Fetch Cycle operation (M1) requires four  $\emptyset$ 1 and  $\emptyset$ 2 clock pulses. Each clock period performs a particular operation as described in the following paragraphs.

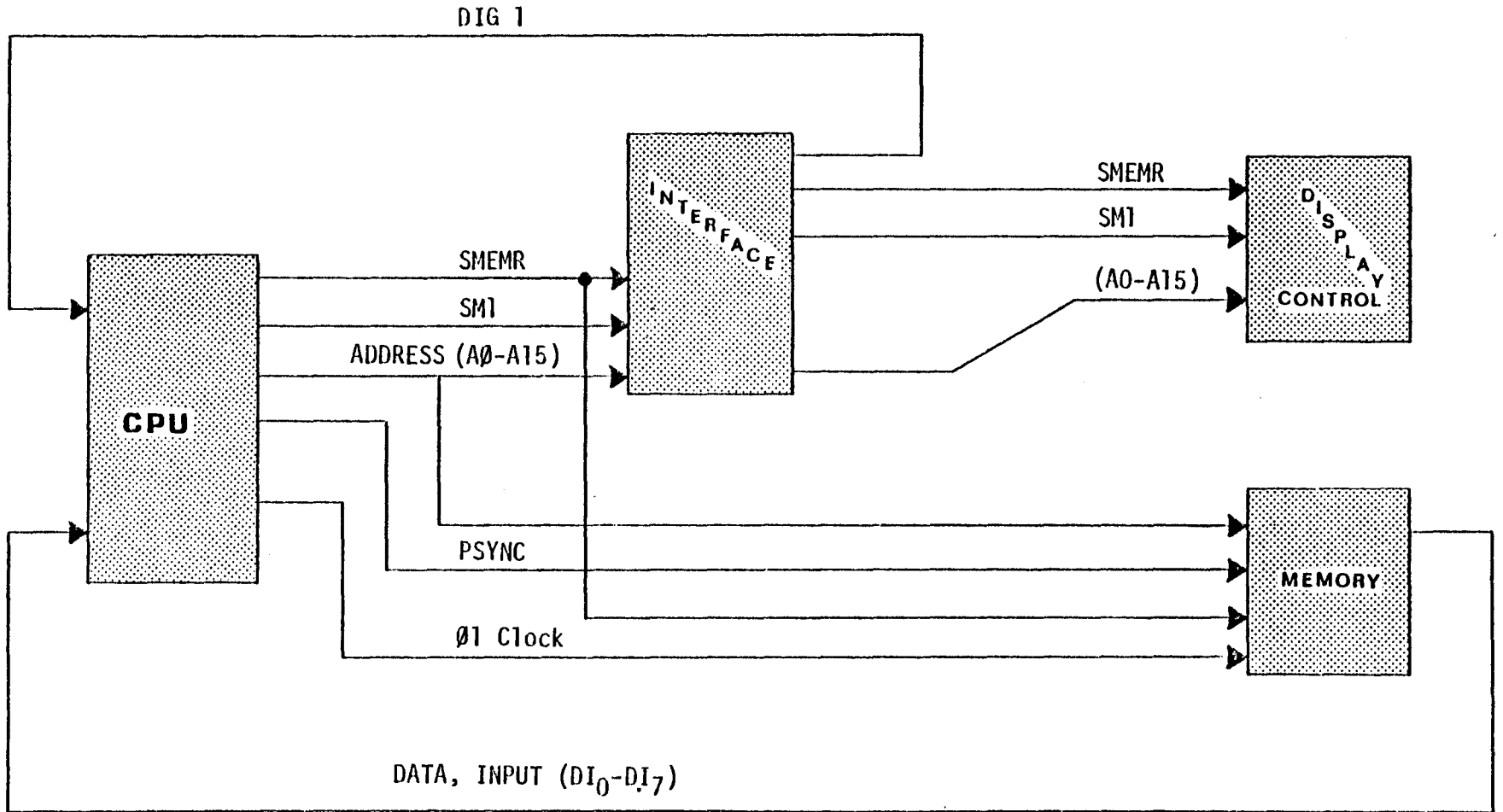

Figure 3-2. Instruction Fetch Cycle Block Diagram

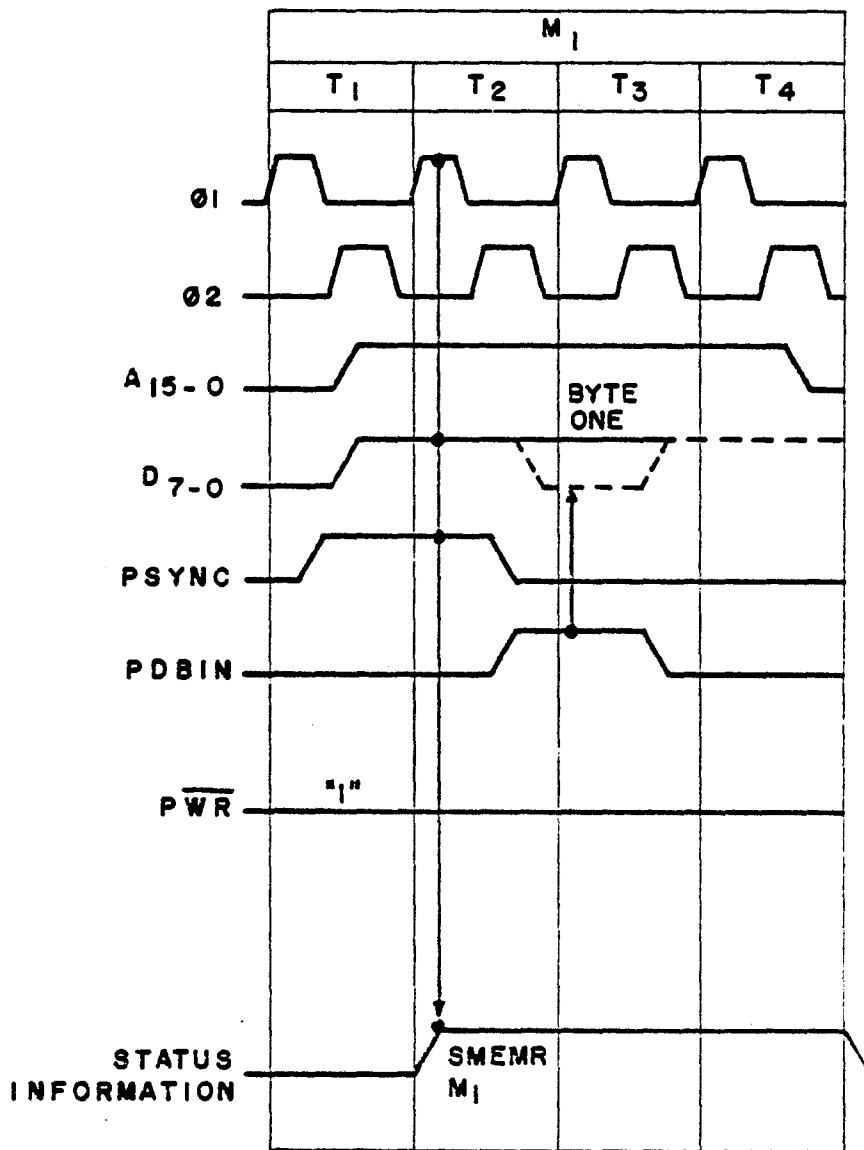

Figure 3-3. Instruction Fetch Cycle Timing.

During the latter portion of T1, several outputs are generated by the CPU (M) (Figure 3-14): address data A0 through A15 (zone B8), status data D0 through D7, and a SYNC signal (zone C8). The A0 through A15 data is applied to memory via the bus through non-inverting bus drivers, U, P, and N (zone B9) on the CPU. The address data (A0-A15) is also applied through inverters P, N, and X on the Interface card (Figure 3-15, sheet 1, zone B5) and presented to the Display/Control card. The A0 through A15 signals present on the Display/Control card light the appropriate A0 through A15 LEDs, indicating the memory address. The D0 through D7 data is applied to K (zone B5) on the CPU through the bi-directional circuits D and E. The status data is enabled through D and E at this time because  $\overline{CS}$  and  $\overline{DIEN}$  are LOW. The SYNC output is applied to the clock generator F (zone B7) and memory as PSYNC via pin 76 (zone D1) on the bus through the non-inverting bus driver V (zone D8). The PSYNC signal conditions memory to decode the address data. The SYNC input at F will enable a signal during T2.

During the beginning of T2, a low  $\overline{STSTB}$  (zone B7) is generated from F as a result of the HIGH SYNC input and internal timing of F. The  $\overline{STSTB}$  is applied to the data latch K (zone B5), allowing the status data D0 through D7 to be stored in K. The status data present at the output of K conditions the memory to fetch the instruction ( $072_8$ ) from its addressed memory location (e.g.  $000\ 100_8$ ) by enabling the following signals.

A SM1 and SMEMR HIGH output from K is presented on pins 44 and 47 of the bus (zone A5) through non-inverting bus drivers X and R. The SM1 and SMEMR signals are applied through inverter V on the Interface card (Figure 3-15, sheet 2, zone B5) and presented to the Display/Control card as  $\overline{SM1}$  and  $\overline{SMEMR}$ . The  $\overline{SM1}$  and  $\overline{SMEMR}$  signals present on the Display/Control card light the M1 and MEMR LEDs (Figure 3-16, sheet 3, zone C3) on the front panel of the 8800b, indicating machine cycle one is performing a memory read operation. The SMEMR output from the CPU (Figure 3-14, zone A5) is applied to memory, initiating a data transfer to the CPU during T3.

At the beginning of T3, the instruction (072<sub>8</sub>) data is transferred from memory to M on the CPU. The memory data (DI<sub>0</sub> through DI<sub>7</sub>) is supplied to the CPU card (Figure 3-14, zone B1) from the bus. The data is presented to M through bi-directional gates D and E (zone C7), inverter bus drivers L and J (zone B4), and inverters Y and S (zone B3) by the DBIN signal.

At the latter portion of T2 and the beginning of T3, a high DBIN output (zone C8) is generated by M. The DBIN output is applied to the  $\overline{DIEN}$  inputs (zone C7) of D and E and pin 4 of NAND gate C (zone B4) as PDBIN. This signal enables pin 6 of NAND gate C LOW (DIG1 is high when the front panel is not used). This allows data input from memory (DI<sub>0</sub>-DI<sub>7</sub>) to be enabled through inverting bus drivers L and J (zone B4) and applied through bi-directional gates D and E to M (zone C7).

Clock period T4 of machine cycle one allows for 8080 processing of the received instruction data from memory. If the instruction data present in the CPU requires a data transfer to or from an external device, a memory read cycle (M2) is initiated. However, if the instruction data present in the CPU requires a data transfer to or from memory, two memory read cycles (M2 and M3) are initiated.

### 3-15. MEMORY READ CYCLE

The Memory Read Cycle (M2) follows the Instruction Fetch Cycle (M1). During a Memory Read Cycle, an address is transferred to the CPU from memory. This address is either an external device number or a memory location (depending upon the instructions received during M1).

### 3-16. MEMORY READ CYCLE OPERATION (Figure 3-4)

The CPU performs one or two Memory Read Cycle operations. If the CPU is to communicate with an external device, one Memory Read Cycle is required because the external device number consists of 8 data

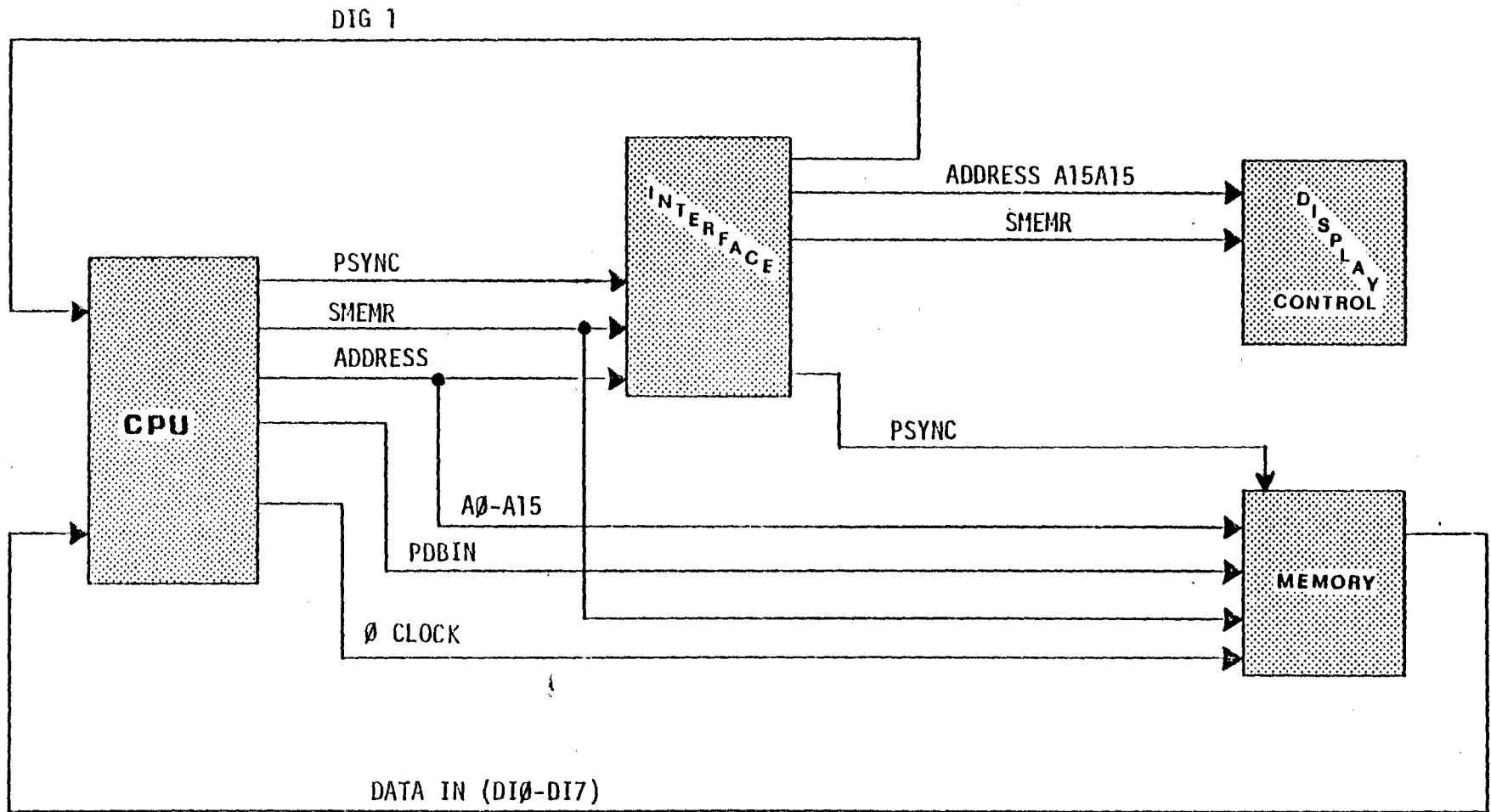

Figure 3-4. Memory Read Cycle Block Diagram

bits (1 byte). However, if the CPU is instructed to communicate with memory, two Memory Read Cycles are required because the memory address consists of 16 data bits (2 bytes).

The two Memory Read Cycles obtain the memory address (e.g.  $000\ 200_8$ ) that is required by the CPU to complete the instruction. Since one byte (8 bits) of the two byte address is transferred during one Memory Read Cycle, two cycles are required. The first Memory Read Cycle obtains the least significant bits (LSBs) of the address ( $200_8$ ) from memory and stores them in the CPU. The second cycle obtains the most significant bits (MSBs) of the address ( $000_8$ ) from memory and stores them in the CPU.

The Memory Read Cycles are very similar to the Instruction Fetch Cycle. They require a memory address location (e.g.  $000\ 101_8$  and  $000\ 102_8$ ) that indicates where the LSBs and MSBs of the address ( $000\ 200_8$ ) are stored. After completion of the Instruction Fetch Cycle, the program counter in the CPU is incremented to  $000\ 101_8$  and the first Memory Read Cycle is initiated. Several signals are generated by the CPU in order to read the LSBs of the address ( $200_8$ ) from memory.

A PSYNC output from the CPU is applied to memory through the Interface Card to condition the memory for address decoding. Next the ADDRESS ( $000\ 101_8$ ), consisting of sixteen parallel outputs ( $A_0$ - $A_{15}$ ) from the CPU, is presented to the Display/Control Card and memory. The  $A_0$  through  $A_{15}$  signals light the appropriate address light emitting diodes (LEDs) on the Display/Control Card. The ADDRESS and PSYNC signals present at the memory from the CPU initiate decoding of the address ( $000\ 101_8$ ).

The CPU then generates three signals, SMEMR, PDBIN, and  $\emptyset 1$  to complete the Memory Read Cycle. The SMEMR, PDBIN, and  $\emptyset 1$  outputs are presented to memory to enable decoding of the address ( $000\ 101_8$ ). With the address decoded, the  $200_8$  data present in that location is transferred to the CPU on the eight DATA IN ( $DI_0$ - $DI_7$ ) lines. The DIGI input to the CPU from the Interface Card is enabled when the 8800b is in the run mode, permitting memory data to be transferred to the CPU.



The SMEMR output is presented to the Display/Control Card through the Interface Card to light the MEMR (memory read) LED on the 8800b front panel. The second Memory Read Cycle operation is identical to the first. It transfers the MSBs of the address ( $000_g$ ) to the CPU.

### 3-17. MEMORY READ CYCLE DETAILED OPERATION

The following paragraphs describe the Memory Read Cycle operation in detail. Refer to Figure 3-5, Memory Read Cycle Timing, during the explanation.

The two Memory Read Cycle operations (M2 and M3) obtain the memory address (e.g.  $000\ 200_g$ ) required by the CPU to complete an instruction. As stated previously, the LSBs of the address ( $200_g$ ) are transferred to the CPU during M2, and the MSBs of the address ( $000_g$ ) are transferred to the CPU during M3. There are three clock periods (T1-T3) required for each Memory Read Cycle operation.

During the latter portion of T1, several outputs are generated by the CPU (Figure 3-14); Address data  $A_0$  through  $A_{15}$  (zone B8), status data  $D_0$  through  $D_7$ , and a SYNC signal (zone C8). The  $A_0$  through  $A_{15}$  data is presented to memory and the 8800b front panel via the bus through non-inverting bus drivers U, P, and N (zone B9) on the CPU. The  $D_0$  through  $D_7$  data is applied to K (zone B5) on the CPU through the bi-directional circuits D and E. The status data is enabled through D and E at this time because  $\overline{CS}$  and  $\overline{DIEN}$  are LOW. The SYNC output is applied to the clock generator F (zone B7) and memory as PSYNC via pin 76 (zone D1) on the bus through non-inverting bus driver V (zone D8). The PSYNC signal conditions memory to decode the address data.

During the beginning of T2, a  $\overline{STSTB}$  (zone B7) is generated (LOW) from F as a result of the HIGH SYNC input and internal timing of F. The  $\overline{STSTB}$  is applied to the data latch K (zone B5), allowing the status data  $D_0$  through  $D_7$  to be stored in K. The status data present at the output of K allows the CPU to read the LSBs of the memory address

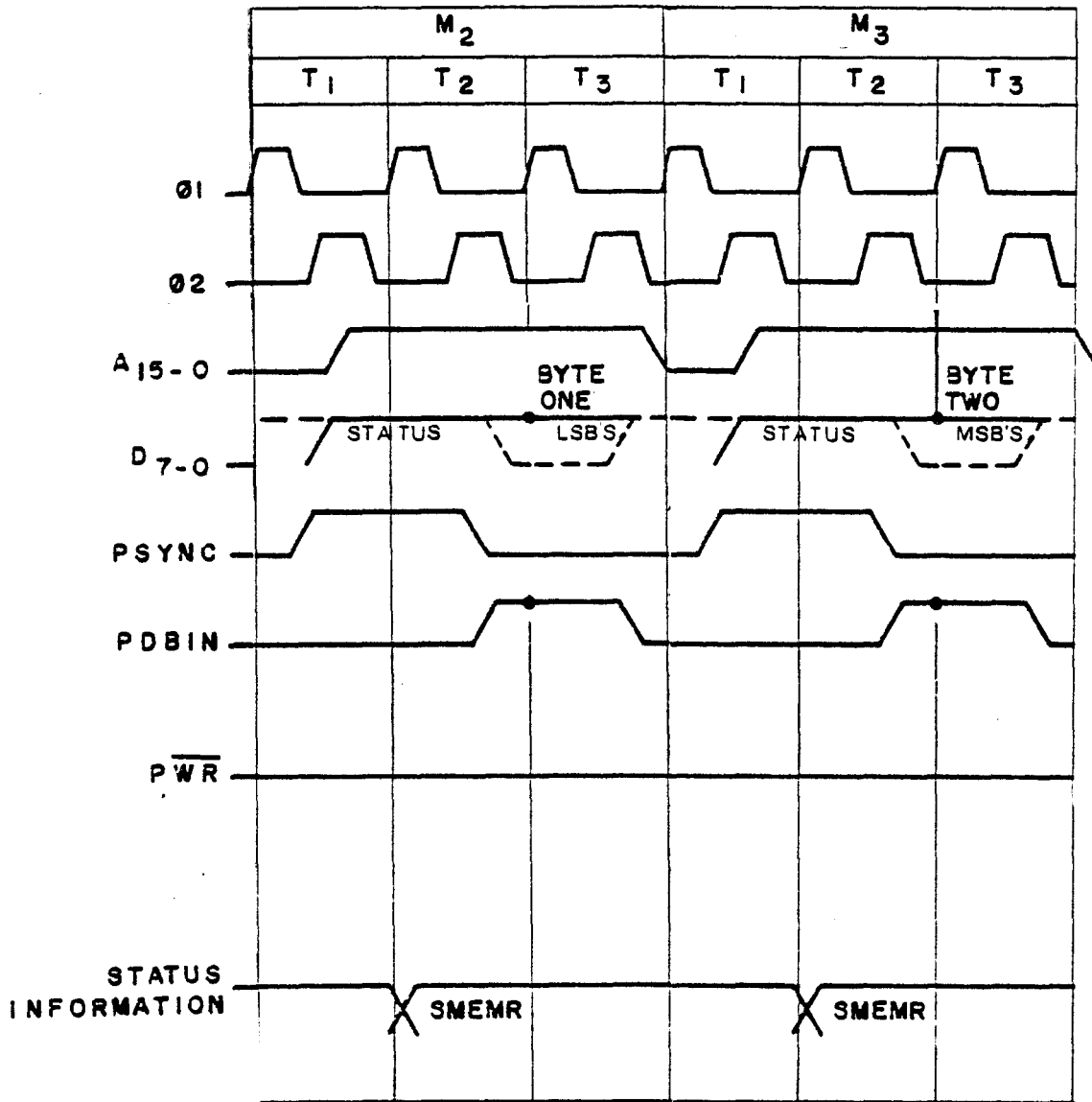

Figure 3-5. Memory Read Cycle Timing.

location (ex. 000 101<sub>g</sub>) by enabling the SMEMR signal.

A SMEMR output (HIGH) from K is presented on pin 47 of the bus (zone A4) through non-inverting bus drivers X and R. The SMEMR signal is applied through inverter V on the Interface Card (Figure 3-15, sheet 2, zone B4) and presented to the Display/Control card as  $\overline{\text{SMEMR}}$ . The  $\overline{\text{SMEMR}}$  signal present on the Display/Control card lights the MEMR LED (Figure 3-16, zone C3) on the front panel of the 8800b, indicating a memory read operation is occurring. The SMEMR output from the CPU (Figure 3-14, zone A5) is applied to memory in order to initiate a data transfer to the CPU during T3.

At the beginning of T3, the LSBs of the memory storage location (200<sub>g</sub>) are transferred from memory to the 8080 (M) on the CPU. The memory data in (DI<sub>0</sub> through DI<sub>7</sub>) is applied to the CPU card (Figure 3-14, zone B1) from the bus. The data is presented to M through bi-directional gates D and E (zone C7), inverter bus drivers L and J (zone B4), and inverters Y and S (zone B3) by the PDBIN signal.

At the latter portion of T2 and the beginning of T3, a DBIN output (zone C8) HIGH is generated by M. The DBIN output is applied to the  $\overline{\text{DIEN}}$  inputs (zone C7) of D and E and pin 4 of NAND gate C (zone B4) as PDBIN. This signal enables pin 6 of NAND gate C LOW (DIG 1 is high when front panel is not used). This allows the data in from memory (DI<sub>0</sub> - DI<sub>7</sub>) to be enabled through inverting bus drivers L and J (zone B4) and applied through bi-directional gates D and E to M (zone C7). The second Memory Read Cycle operation (M3) transfers the contents of memory address (000 102<sub>g</sub>) which contain the MSBs of the memory address number to the CPU. It is important to note that only one Memory Read Cycle operation is required if the CPU is to communicate with an external device.

### 3-18. EXTERNAL DEVICE TO CPU DATA TRANSFER

An External Device to CPU data transfer is accomplished when an input instruction (333<sub>g</sub>) is fetched from a memory location during M1, and the external device number (XXX<sub>g</sub>) is read from a memory location during M2 by the CPU. The data from the external device is transferred to the CPU by an Input Read Cycle operation (M3).

### 3-19. INPUT READ CYCLE OPERATION (Figure 3-6)

The Input Read Cycle operation will allow the CPU to obtain data from an external device. After the completion of the Memory Read Cycle (M2), the program counter is not incremented until the completion of the Input Read Cycle. Several signals are generated by the CPU in order to obtain data from the external device.

The SINP output and external device ADDRESS ( $XXX_8$ ) number, consisting of the first eight individual outputs (A0-A7) from the CPU, is presented to the external device input/output channel, thereby enabling the I/O card. With the I/O enabled, a PDBIN signal from the CPU allows the I/O to transfer the external device data to the CPU on the eight DATA IN (DI0-DI7) lines for storage. The DIG 1 input to the CPU from the Interface is enabled during the 8800b run mode and allows the external device data to be stored in the CPU. The SINP and A0 through A15 outputs are supplied to the Display/Control Card through the Interface Card to illuminate the INP (input) and ADDRESS LEDs on the 8800b front panel.

### 3-20. INPUT READ CYCLE DETAILED OPERATION

The following paragraphs describe the Input Read Cycle operation in detail. Refer to Figure 3-7, Input Read Cycle Timing, during the explanation. The Input Read Cycle operation (M3) requires three  $\phi 1$  and  $\phi 2$  clock pulses. During each clock period, a specific operation is performed as described in the following paragraphs.

During the latter portion of T1, several outputs are generated by the CPU (Figure 3-14); address data A0 through A15 (zone B8), status data D0 through D7, and a SYNC signal (zone C8). The A0 through A15 data contains the external device number (A0-A7 and A8-A15 contain identical data) and is applied to the I/O card via the bus through non-inverting bus drivers U, P, and N (zone B9) on the CPU in order to enable the I/O card. The address data (A0-A15) is also applied through inverters P, W, and X on the Interface Card (Figure 3-15, sheet 1, zone B5) and

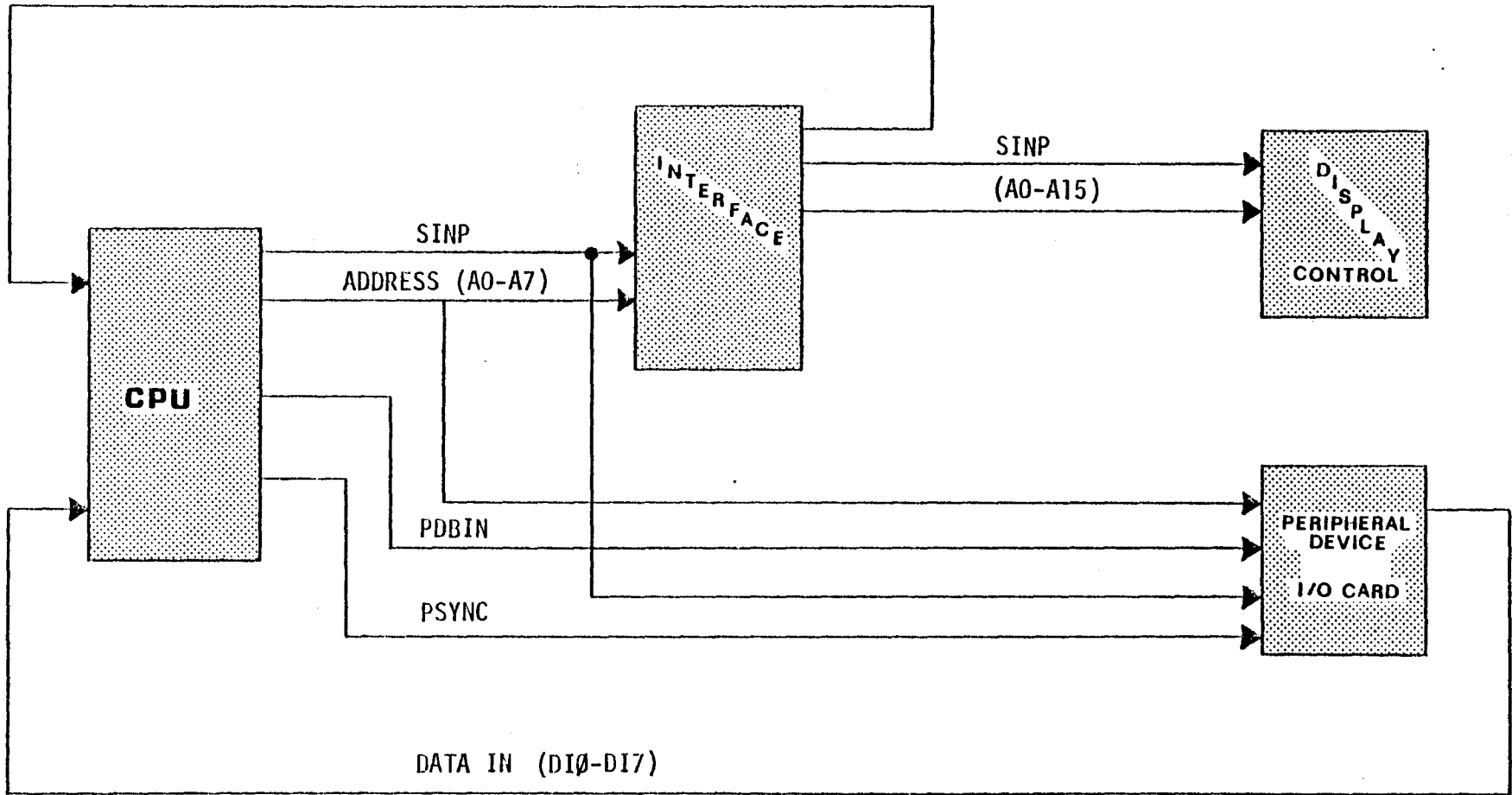

Figure 3-6. Input Read Cycle Block Diagram

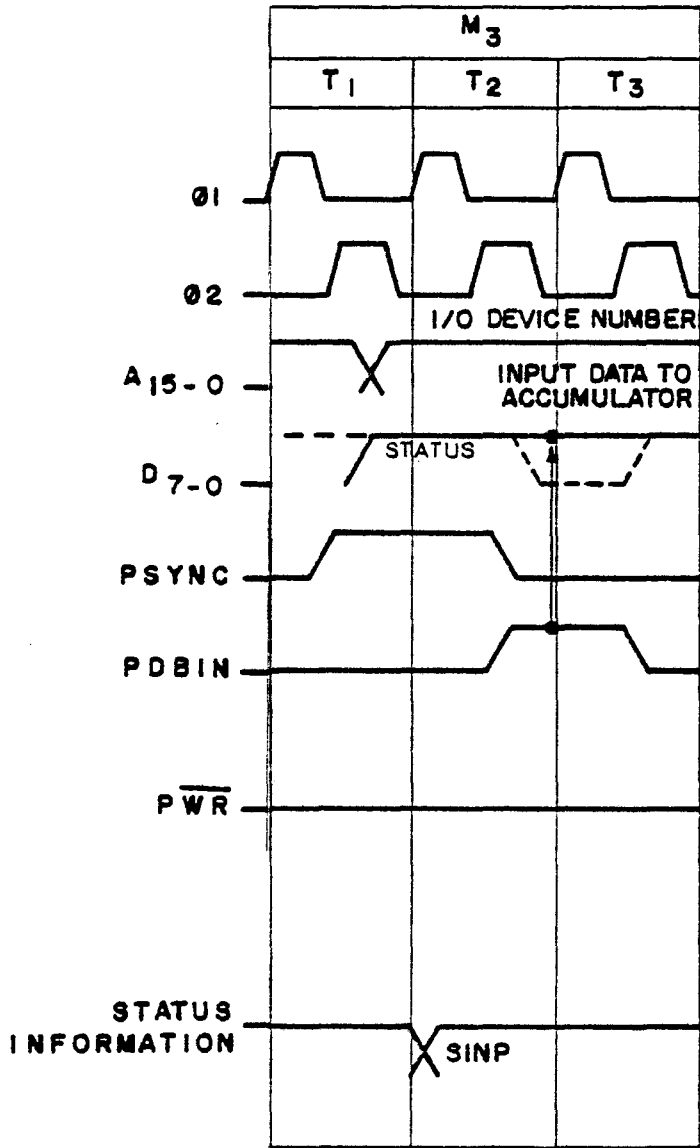

Figure 3-7. Input Read Cycle Timing.

presented to the Display/Control card. The A0 through A15 signals present on the Display/Control card (Figure 3-16, sheet 3, zone A9-A4) light the appropriate A0 through A15 LEDs, indicating the address of the external device. (Recall that when addressing an I/O device, the address is repeated on the upper eight and lower eight address LEDs.) The D0 through D7 data is applied to K (Figure 3-14, zone B5) on the CPU through the bi-directional circuits D and E. The status data is enabled through D and E at this time because  $\overline{CS}$  and  $\overline{DIEN}$  are LOW. The SYNC output is applied to the clock generator F (zone B7), conditioning F to generate a signal during T2.

At the beginning of T2, a  $\overline{STSTB}$  (zone B7) is generated LOW from F as a result of the HIGH SYNC input and internal timing of F. The  $\overline{STSTB}$  is applied to the data latch K (zone B5), allowing the status data D0 through D7 to be stored into K. The status data present at the output of K conditions the I/O card to send data to the CPU by enabling the S $\overline{INP}$  signal.

A S $\overline{INP}$  output from K is presented HIGH on pin 46 of the bus (zone A4) through non-inverting bus driver R. The S $\overline{INP}$  signal is applied through inverter V on the Interface Card (Figure 3-15, sheet 2, zone B5) and presented to the Display/Control card as  $\overline{SINP}$ . The  $\overline{SINP}$  signal present on the Display/Control card lights the INP LED (Figure 3-16, sheet 3, zone C3) on the front panel of the 8800b, indicating data is being received from an external device. The S $\overline{INP}$  output from the CPU is applied to the external device I/O card in order to initiate a data transfer to the CPU during T3.

At the beginning of T3, the external device data is transferred to M on the CPU via the bus. The external device data in (DI0 through DI7) is applied to the CPU card (Figure 3-14, zone B1) from the bus. The data is presented to the 8080 (M) through bi-directional gates D and E (zone C7), inverter bus drivers L and J (zone B4), and inverters Y and S (zone B3) by the PDBIN signal.

At the latter portion of T2 and the beginning of T3, a DBIN output (zone C8) HIGH is generated by M. The DBIN output is applied to the  $\overline{DIEN}$  inputs (zone C7) of D and E, pin 4 of NAND gate C (zone B4) and the bus pin 78 (zone D1) as PDBIN. This

signal enables pin 6 of NAND gate C LOW (DIG 1 is HIGH when the front panel is not used), allowing the data input from the I/O card (DI0-DI7) to be enabled through inverting bus drivers L and J (zone B4) and applied through bi-directional gates D and E to M (zone C7). The data at the external device is presented on the bus by the occurrence of PDBIN. After the external device data is stored in the CPU, the P counter is incremented, thus ending the Input Read Cycle operation.

### 3-21. CPU TO MEMORY DATA TRANSFER

A CPU to Memory data transfer is accomplished whenever an instruction is encountered to perform this operation. For example, a store accumulator STA (062<sub>g</sub>) instruction requires the accumulator in the CPU to transfer its contents to memory. The STA instruction is fetched during M1 and its storage location determined in memory read cycles M2 and M3. The accumulator data is transferred to memory by a Memory Write Cycle operation (M4).

### 3-22. MEMORY WRITE CYCLE BASIC OPERATION (Figure 3-8)

The Memory Write Cycle operation will allow the CPU to transfer data to the memory. Several signals are generated by the CPU in order to transfer data to the memory.

The  $\overline{SWO}$  output from the CPU is applied to the Display/Control through the Interface to light the W0 (write out) LED on the 8800b front panel. The ADDRESS (XXX XXX<sub>g</sub>), consisting of fifteen individual outputs (A0-A15) from the CPU, is presented to the Display/Control and memory. The A0 through A15 signals light the appropriate address LEDs on the Display/Control. The ADDRESS and PSYNC signals present at the memory from the CPU can also initiate decoding of the memory address. With the memory conditioned, eight DATA OUT lines (DO0-DO7) transfer the CPU data to the memory for storage. The  $\overline{PWR}$  and  $\overline{SOUT}$  outputs from the CPU are applied to the Interface to produce a MWRITE signal which allows the memory to store the data.



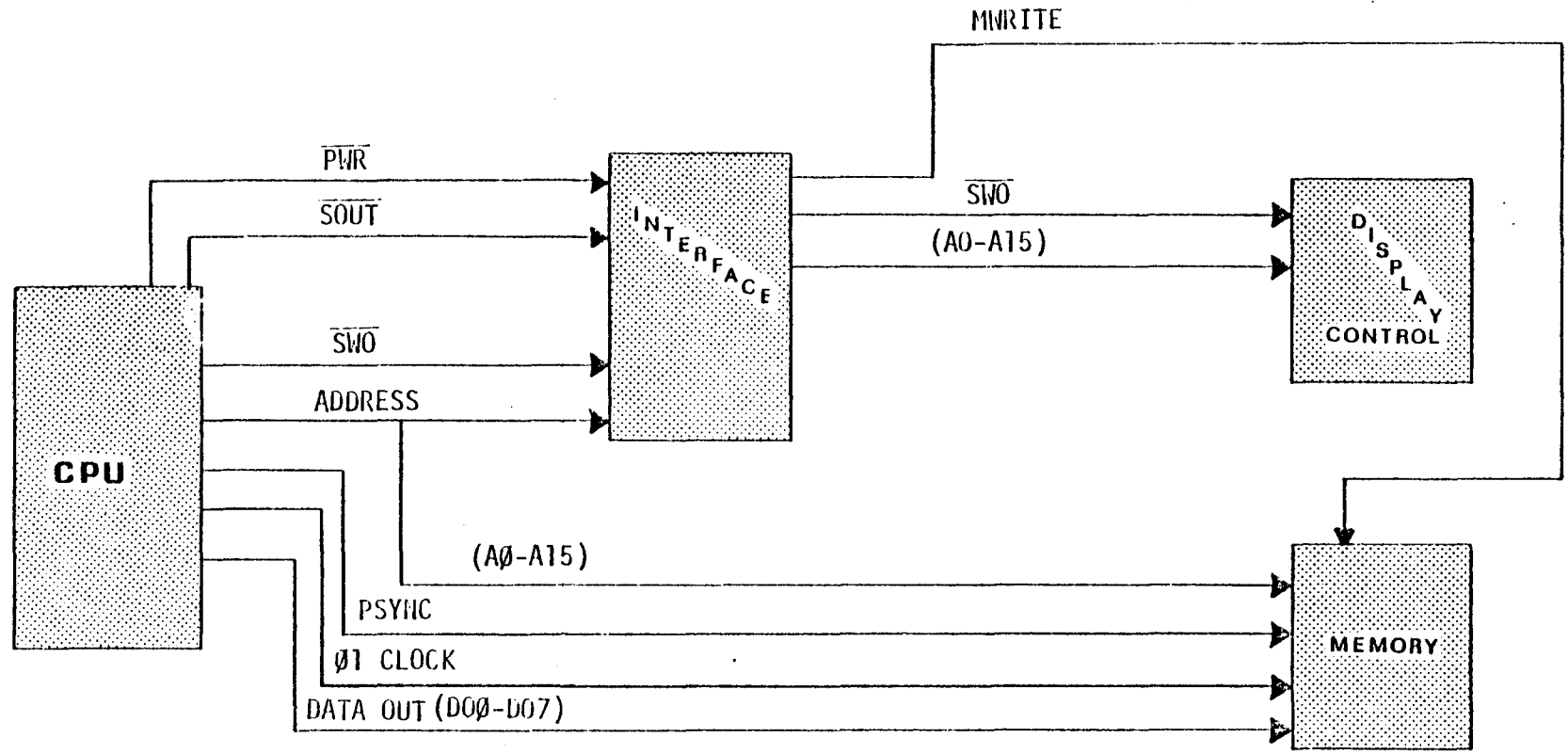

Figure 3-8. Memory Write Cycle Block Diagram

### 3-23. MEMORY WRITE CYCLE DETAILED OPERATION

The following paragraphs describe the Memory Write Cycle operation in detail. Refer to Figure 3-9, Memory Write Cycle Timing, during the explanation. The Memory Write Cycle operation (M4) requires three  $\phi 1$  and  $\phi 2$  clock pulses. Each period performs a certain operation as described in the following paragraphs.

During the latter portion of T1, several outputs are generated by the CPU 8080 IC (Figure 3-14); Address data A0 through A15 (zone B8), status data D0 through D7, and a SYNC signal (zone C8). The A0 through A15 data contains the memory storage location address (ex. 000 200<sub>g</sub>) which is applied to the memory card via the bus through non-inverting bus drivers U, P, and N (zone B9) on the CPU in order to enable the memory. The address data (A0-A15) is also applied through inverters P, W, and X on the Interface Card (Figure 3-15, sheet 1, zone B5) and presented to the Display/Control card. The A0 through A15 signals present on the Display/Control card (Figure 3-16, sheet 3, zones A9-A5) light the appropriate A0 through A15 LEDs, indicating the memory location address. The D0 through D7 data is applied to K on the CPU (Figure 3-14, zone B5) through the bi-directional circuits D and E. The status data is enabled through D and E at this time because  $\overline{CS}$  and  $\overline{DIEN}$  are LOW. The SYNC output is applied to the clock generator F (zone B7), conditioning F to generate a signal during T2.

During the beginning of T2, a LOW  $\overline{STSTB}$  (zone B7) is generated from F as a result of the HIGH SYNC input and internal timing of F. The  $\overline{STSTB}$  is applied to the data latch K (zone B5) allowing the status data D0 through D7 to be stored into K. The status data present at the output of K indicates a write output operation is being performed. However, the distinction of whether the data from the CPU is being transferred to a memory or an external device is determined by the status of the SOUT signal (zone A5). During a Memory Write Cycle, the SOUT signal is LOW and applied to the Interface Card (Figure 3-15, sheet 2). The SOUT signal is inverted HIGH by V and applied to pin 2 of NAND gate A (zone C3).

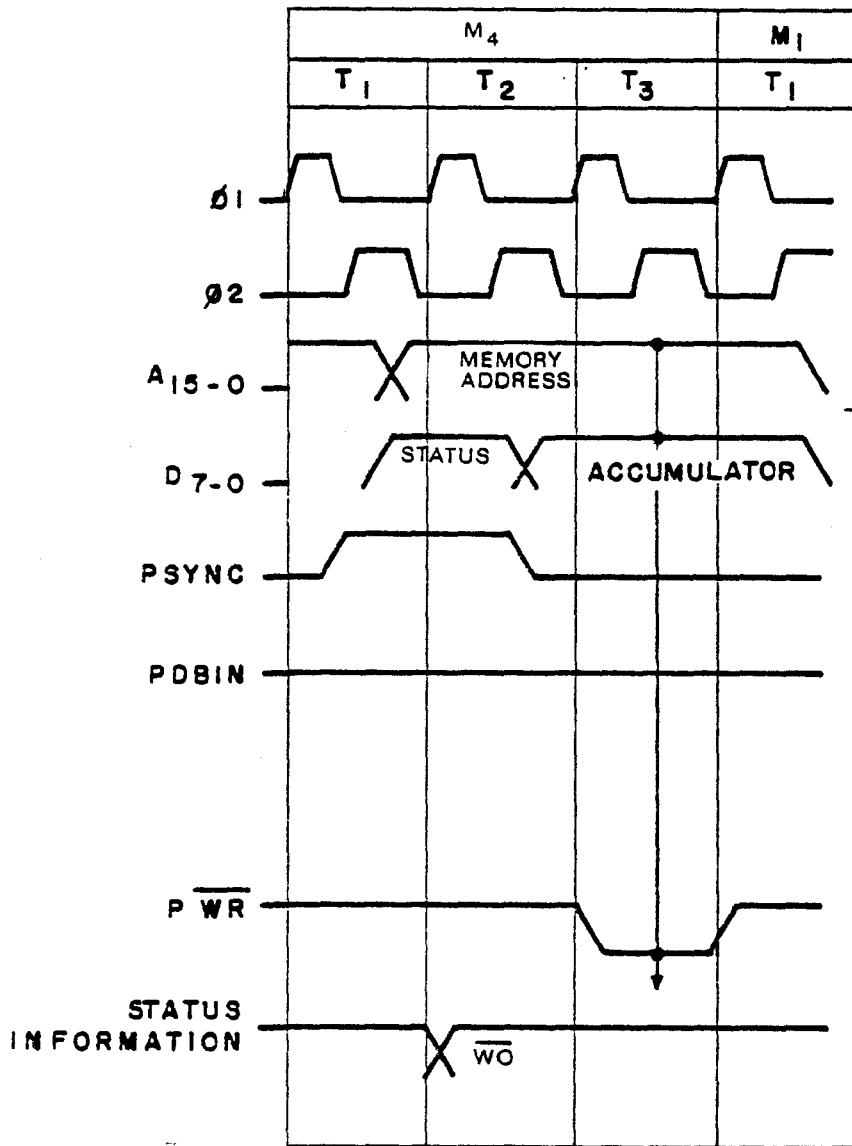

Figure 3-9. Memory Write Cycle Timing.

The  $\overline{SWO}$  output from K is presented on pin 97 of the bus (zone A4) through non-inverting bus driver X as a LOW. The  $\overline{SWO}$  signal is applied through inverter M on the Interface Card (Figure 3-15, sheet 2, zone B6) and presented to the Display/Control card as SWO. The SWO signal present on the Display/Control card lights the WO LED (Figure 3-16, zone C3) on the front panel of the 8800b, indicating data is being transferred to memory from the CPU.

At the beginning of T3, the CPU data is transferred to the memory via the bus. The CPU data out (D00 through D07) is applied to the bus (zone C1) through bi-directional gates D and E ( $\overline{CS}$  and  $\overline{DIEN}$  are LOW) and non-inverting bus drivers M and W (zones C7 and C3). The bus data is presented to memory and written in by the MWRITE signal.

After the CPU data is settled on the bus and presented to memory, a  $\overline{WR}$  signal (zone C8) is generated LOW by M. The  $\overline{WR}$  signal is applied to pin 77 (zone D1) of the bus through non-inverting bus driver V (zone D8) as  $\overline{PWR}$ . The  $\overline{PWR}$  signal is inverted HIGH by U on the Interface Card (Figure 3-15, sheet 2, zone B3) and applied to pin 1 of NAND gate A (zone C3), enabling pin 6 LOW ( $\overline{SOUT}$  is HIGH on pin 2). The LOW at pin 6 forces the output of NOR gate A (zone C2) HIGH which is applied to pin 68 of the bus through non-inverting bus driver H (zone B2) as MWRITE. The MWRITE signal allows the memory to store the CPU data in the addressed memory location, thus completing the CPU to memory data transfer.

### 3-24. MEMORY TO CPU DATA TRANSFER

A Memory to CPU data transfer is accomplished whenever an instruction is encountered to perform this operation. For example, a load accumulator LDA (072<sub>g</sub>) instruction requires the specified addressed memory location to transfer its contents to the accumulator in the CPU. The LDA instruction was fetched during M1 and the specified memory location determined during the memory read cycles, M2 and M3. The memory data is transferred to the CPU by an additional Memory Read Cycle operation (M4). The M4 operation

requires the CPU to output the specified addressed memory location to memory, allowing the data in the specified addressed memory location to be transferred to the CPU in an identical manner as M2.

For a detailed operation description of the M2 cycle, refer to Paragraph 3-17. Note as you read the description that the specified memory address location is presented to memory on the fifteen individual address lines, allowing that location to transfer its data to the CPU.

### 3-25. CPU TO EXTERNAL DEVICE DATA TRANSFER

A CPU to External Device data transfer is accomplished when an output instruction ( $323_g$ ) is fetched from a memory location during M1, and the external device number ( $XXX_g$ ) is read from a memory location during M2 by the CPU. The data from the CPU is transferred to the external device by an Output Write Cycle operation (M3).

### 3-26. OUTPUT WRITE CYCLE BASIC OPERATION (Figure 3-10)

The Output Write Cycle operation will allow the CPU to output data to an external device. After completion of the Memory Read Cycle (M2), the program counter is not incremented until the completion of the Output Write Cycle. Several signals are generated by the CPU in order to transfer the data to the external device.

The SOUT and PSYNC external device ADDRESS ( $XXX_g$ ) number, consisting of sixteen individual outputs (A0-A7) from the CPU, is presented to the external device (I/O) to condition the I/O card. With the I/O conditioned, a  $\overline{PWR}$  signal from the CPU allows the I/O to transfer the CPU data via the DATA OUT (D00-D07) lines to the external device. The  $\overline{SWO}$  output from the CPU is presented to the Display/Control through the Interface to light the W0 (write output) LED on the 8800b front panel. The SOUT and A0 through A15 outputs are applied to the Display/Control through the Interface to light the OUT output and ADDRESS LEDs on the 8800b front panel.

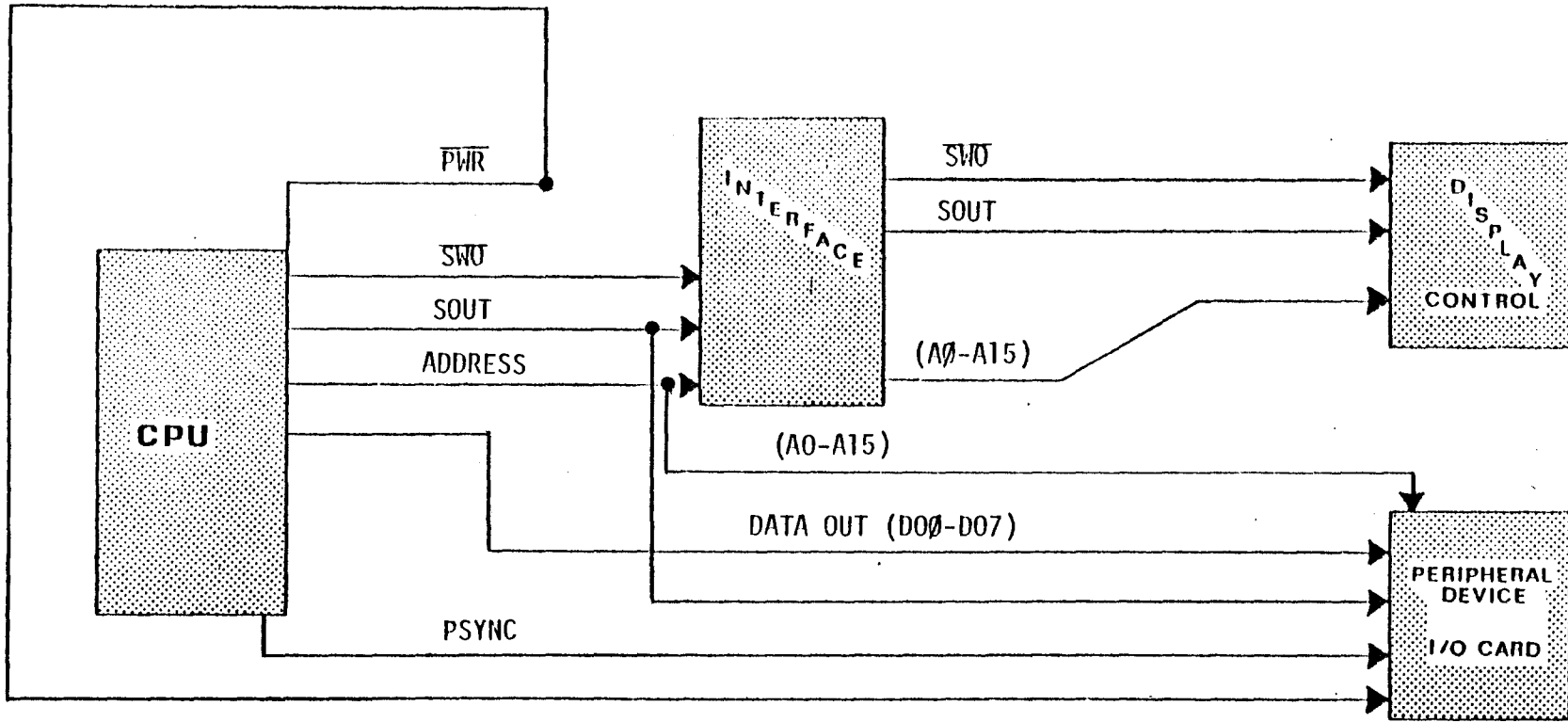

Figure 3-10. Output Write Cycle Block Diagram

### 3-27. OUTPUT WRITE CYCLE DETAILED OPERATION

The following paragraphs describe the Output Write Cycle operation in detail. Refer to Figure 3-11, Output Write Cycle Timing, during the explanation. The Output Write Cycle operation (M3) requires three  $\phi 1$  and  $\phi 2$  clock pulses. Each clock period performs a certain operation as described in the following paragraphs.

During the latter portion of T1, several outputs are generated by the CPU 8080 IC (Figure 3-14); Address data A0 through A15 (zone B8), status data D0 through D7, and a SYNC signal (zone C8). The A0 through A15 data contains the external device number and is applied to the I/O card via the bus through non-inverting bus drivers U, P, and N (zone B9) on the CPU in order to enable the I/O card. The address data (A0-A15) is also applied through inverters P, W, and X on the Interface Card (Figure 3-15, sheet 1, zone B5) and presented to the Display/Control card. The A0 through A15 signals present on the Display/Control card light the appropriate A0 through A15 LEDs, indicating the address of the external device. The D0 through D7 data is applied to K (zone B5) on the CPU through bi-directional circuits D and E. The status data is enabled through D and E at this time because  $\overline{CS}$  and  $\overline{DIEN}$  are LOW. The SYNC output is applied to the clock generator F (zone B7) which conditions F to generate a signal during T2.

At the beginning of T2, a  $\overline{STSTB}$  (zone B7) is generated LOW from F as a result of the HIGH SYNC input and internal timing of F. The  $\overline{STSTB}$  is applied to the data latch K (zone B5), allowing the status data D0 through D7 to be stored into K. The status data present at the output of K conditions the I/O card to receive data from the CPU by enabling the SOUT and  $\overline{SWO}$  signals.

A SOUT output from K is presented HIGH on pin 45 of the bus (zone A4) through non-inverting bus driver X. The SOUT signal is applied through inverter V on the Interface Card (Figure 3-15, zone B5) and presented to NAND gate A (zone C3) and the Display/Control card as SOUT. The  $\overline{SOUT}$  signal disables NAND gate A to insure that a MWRITE output is not produced when writing data to an external

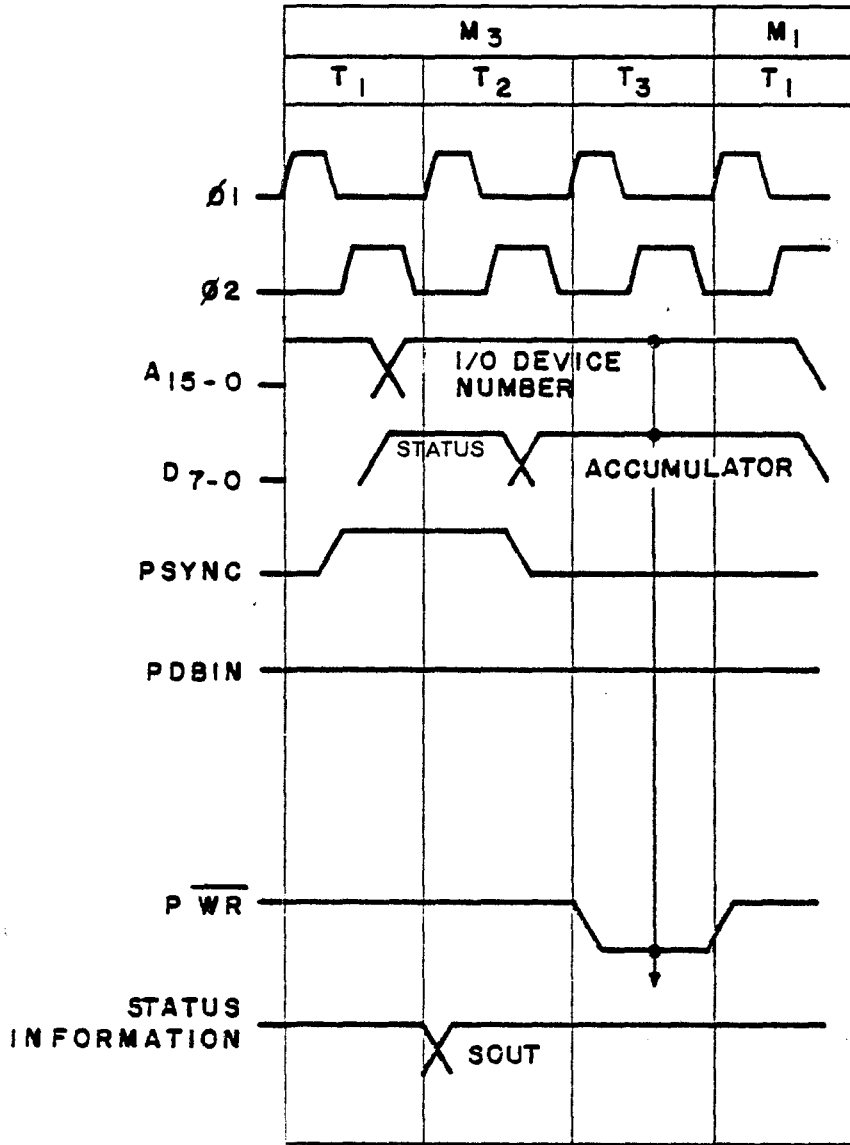

Figure 3-11. Output Write Cycle Timing.



device. It is applied to the Display/Control to light the "OUT" LED (Figure 3-16, sheet 3, zone B3), indicating data is being transferred from the CPU to an external device. The SOUT output from the CPU (Figure 3-14, zone A5) is applied to the external device I/O card in order to initiate a data transfer from the CPU during T3.

At the beginning of T3, the CPU data is transferred to the external device via the bus. The CPU data out (D00 through D07) is applied to the bus (zone C1) through bi-directional gates D and E ( $\overline{CS}$  and  $\overline{DIEN}$  are LOW) and non-inverting bus drivers M and W (zones C7 and C3). The bus data is presented to the external device and written in by the  $\overline{PWR}$  signal.

After the CPU data is settled on the bus, a  $\overline{WR}$  signal (zone C8) is generated LOW by M. The  $\overline{WR}$  signal is applied to pin 77 (zone D1) of the bus through non-inverting bus driver V (zone D8) as  $\overline{PWR}$ . The  $\overline{PWR}$  signal allows the external device to store the CPU data, thus completing the CPU to external device data transfer.

### 3-28. FRONT PANEL OPERATION

A variety of functions may be performed through the operation of the front panel: e.g. selecting a starting location for a program, examining memory locations, single stepping through a program, depositing and displaying CPU accumulator data, and depositing data into a specified memory location. Each of the functions performed on the 8800b front panel are discussed in the following paragraphs. The run operation was discussed in Paragraph 3-10.

### 3-29. FRONT PANEL BLOCK DIAGRAM (Figure 3-12)

The front panel switches allow the operator to assume control of the CPU. The CPU is controlled by a FRDY signal which is generated from the front panel display control circuits. The FRDY signal places the CPU in either a wait condition or a run operation.

The CPU is placed in a wait condition when the Switches and Decoding circuits sense that the RUN/STOP switch on the front panel is positioned to STOP. A STOP signal is applied to the Stop/Run

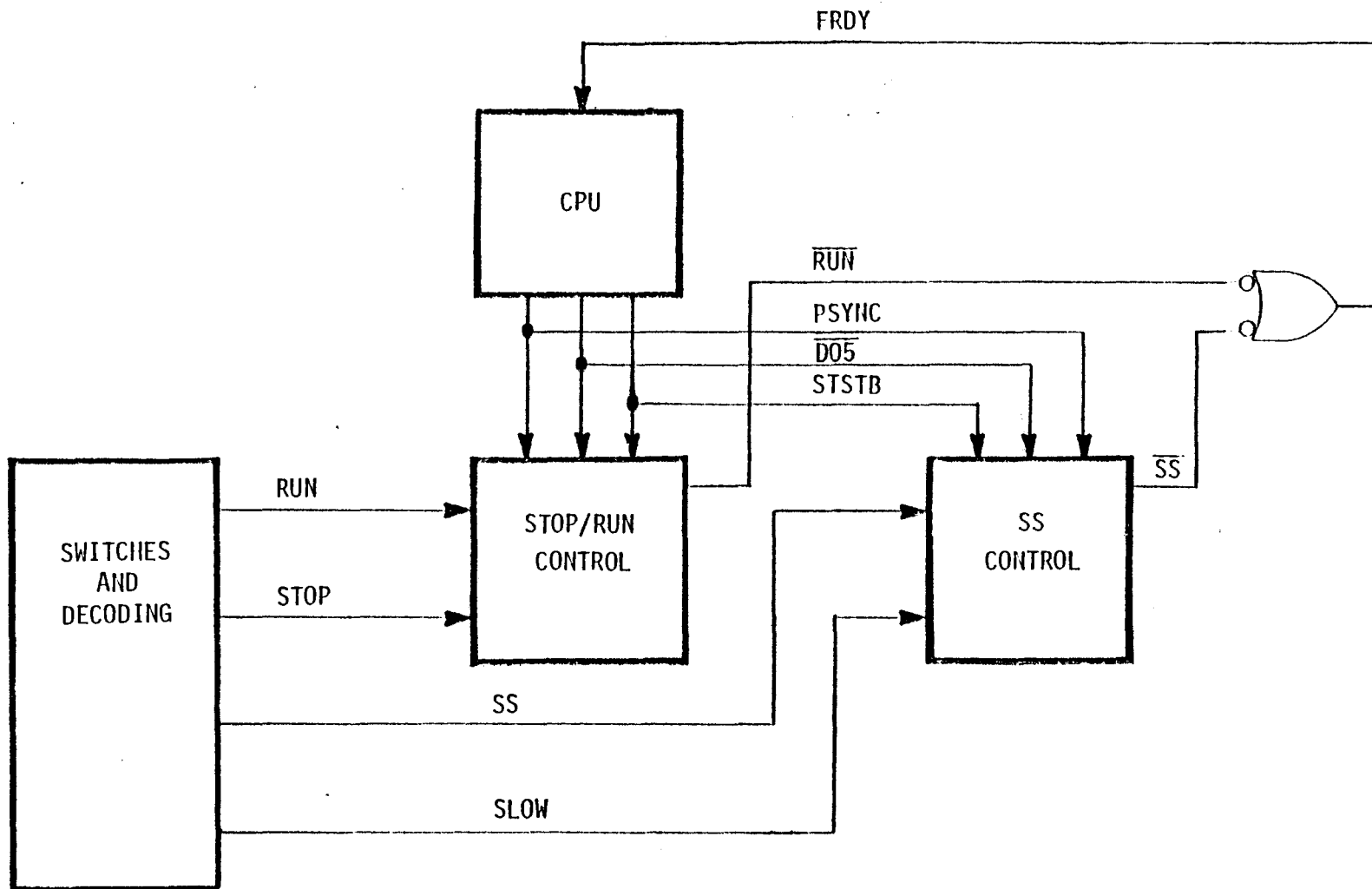

Figure 3-12. Front Panel Block Diagram

Control circuits to disable (HIGH) the  $\overline{\text{RUN}}$  signal. The  $\overline{\text{RUN}}$  signal forces the CPU to a wait condition by disabling (LOW) the FRDY line. The CPU will not enter a wait condition until the PSYNC,  $\overline{\text{D05}}$ , and STSTB signals are presented to the Stop/Run Control circuits. The presence of these signals insures that the CPU will stop during the first machine cycle of an instruction cycle.

The CPU is placed in a single step (SS) or slow run operation by the generation of an SS or SLOW signal from the Switches and Decoding circuits. The SS or SLOW run operation allows the CPU to perform one instruction cycle. The SS signal is applied to the SS Control circuit, enabling (LOW) the  $\overline{\text{SS}}$  signal. The  $\overline{\text{SS}}$  signal allows the CPU to execute one instruction cycle by enabling the FRDY signal. Upon the completion of the instruction cycle, the CPU attempts to perform another instruction cycle, but the PSYNC,  $\overline{\text{D05}}$ , and STSTB signals reset the SS Control circuits forcing the CPU to a wait condition.

### 3-30. STOP OPERATION

The stop operation allows the operator to use the switches on the 8800b front panel. The stop operation is activated when the RUN/STOP switch on the 8800b front panel is momentarily depressed to STOP.

The RUN/STOP circuits are located on the Display/Control card (Figure 3-16, sheet 2, zone A9). With the RUN/STOP switch momentarily depressed, a LOW is applied to quad latch C1, input D1. The occurrence of the next C13 clock (zone A1) causes the  $\overline{\text{Q}}$  output at pin 3 of C1 (zone B9) to go HIGH which is applied to quad latch N1, input D1. The next C13 clock causes the Q output at pin 7 of N1 (zone B9) to go HIGH which is applied to the D input of M1. A HIGH present at D produces a clock pulse to set M1, stopping the CPU.

The clock pulse that sets M1 is derived from three signals:  $\overline{\text{D05}}$ ,  $\overline{\text{PSYNC}}$ , and  $\overline{\text{STSTB}}$  (zone D8). The signals are enabled during machine cycle 1 (paragraph 3-14) of an 8800b instruction cycle, and their presence generates a clock to M1 (zone C9). This insures that the 8800b stops during the first machine cycle of an instruc-

tion cycle. The D05 signal is generated by the CPU (Figure 3-14, zone C1) and presented to pin 39 of the bus as a HIGH through the bi-directional gate E (zone C7) and non-inverting bus driver W (zone C3) and applied to the Interface Card (Figure 3-15, sheet 2, zone C2). The D05 signal is inverted by Y (zone B2) and inverted again by R1 on the Display/Control Card (Figure 3-16, sheet 2, zone D8) and applied HIGH to pin 3 of NAND gate D1 (zone C8). The PSYNC is generated by the CPU (Figure 3-14, zone D1) on pin 76 of the bus as a HIGH through non-inverting bus driver V (zone D8) and applied to the Interface Card (Figure 3-15, sheet 2, zone A3). PSYNC is inverted by U (zone B3) and R1 on the Display/Control Card (sheet 5, zone B3) and applied HIGH to pin 4 of NAND gate D1 (zone C8).

The  $\overline{STSTB}$  is generated by the CPU (Figure 3-14, zone A4) to pin 56 of the bus as a LOW through non-inverting bus driver R and applied to the Interface Card (Figure 3-15, sheet 2, zone A4). The  $\overline{STSTB}$  is inverted and then inverted again by the Interface Card (sheet 2, zone A4) and applied to pin 5 of NAND gate D1 on the Display/Control Card (Figure 3-16, sheet 2, zone C8) as a HIGH. These signals allow NAND gate D1 to produce a HIGH at gate P1, pin 6 (zone C8), which sets M1. The  $\overline{Q}$  output of M1 goes LOW and is applied through K1 (zone A8) to enable all the front panel switches. The  $\overline{Q}$  output is also presented to gate P1 which keeps a high on the CK input of M1 (zone C9), insuring that M1 remains set after the stop switch is released.

Because M1 is set, the Q output of M1 (zone C9) is HIGH, disabling the  $\overline{RUN}$  and  $\overline{FRDY}$  signals. The  $\overline{FRDY}$  signal is applied to NAND gate C on the CPU (Figure 3-14, zone A8) through the Interface (Figure 3-15, sheet 2, zone A1) as a LOW. This inhibits the RDYIN signal at F (Figure 3-14, zone B7) which disables the READY signal to M (zone A8), thereby halting the CPU.

### 3-31. SINGLE STEP OPERATION

The single step operation allows the operator to increment one instruction cycle at a time. The single step operation is activated when the SINGLE STEP/SLOW switch is momentarily positioned to SINGLE STEP.

The SINGLE STEP circuits are located on the Display/Control card (Figure 3-16, sheet 1, zone A8). With the SINGLE STEP/SLOW

switch momentarily positioned to SINGLE STEP, a LOW is presented to pin 1 of gate P1 (zone C8). The LOW input at D1 generates a clock pulse which sets M1 (zone A7), producing a LOW at the  $\bar{Q}$  output of M1. The LOW output is applied to pin 13 of gate P1 (zone C9), enabling the  $\overline{FRDY}$  signal (zone D9). The CPU performs one instruction cycle with  $\overline{FRDY}$  enabled. At the completion of the instruction cycle, the  $\overline{D05}$ ,  $\overline{PSYNC}$ , and  $\overline{STSTB}$  input (zone D8) enable NAND gate T1, pin 12 (zone C6), LOW which produces a LOW at the output of inverter J1 (zone C6). The LOW clears the M1 flip-flop, thereby ending the first single step operation. Additional single step operations are enabled by momentarily depressing the SINGLE STEP/SLOW switch to SINGLE STEP.

The D05 input is applied to pin 1 of NAND gate T1 through jumpers JE and JF (zone D7). If this jumper is removed, pin 1 of NAND gate is always HIGH. Under this condition, the  $\overline{PSYNC}$  and  $\overline{STSTB}$  signals would reset M1 after each machine cycle.

### 3-32. SLOW OPERATION

The slow operation is very similar to the single step operation except the slow operation allows the 8800b to execute instruction cycles at a very slow rate (786 milliseconds vs. 3 milliseconds normal operation).

The slow circuits are located on the Display/Control card (Figure 3-16, sheet 2, zone A8). When the SINGLE STEP/SLOW switch is positioned to SLOW, a HIGH is presented to pin 9 of NAND gate P1 (zone B7). The HIGH at pin 9 enables the C18 clock (zone D7) from a 24-bit counter (sheet 1, zone D1) through NAND gate P1 (sheet 2, zone B7). This clock enables pin 12 of gate D1 (zone C8) HIGH, providing a clock pulse to set M1 (zone A7), producing a LOW at the  $\bar{Q}$  output, M1. The LOW output is applied to pin 13 of gate P1 (zone C9), enabling the  $\overline{FRDY}$  signal (zone D9). With  $\overline{FRDY}$  enabled, the CPU performs one instruction cycle. At the completion of the instruction cycle, the  $\overline{D05}$ ,  $\overline{PSYNC}$ , and  $\overline{STSTB}$  input (zone D8) enable NAND gate T1, pin 12 (zone C6), LOW which produces a LOW at the output of inverter J1 (zone C6). This LOW clears the M1 flip-flop, ending the first single step operation. If the SINGLE STEP/

SLOW switch is still positioned to SLOW, another instruction cycle operation is performed. Otherwise, the machine halts. If jumpers JE and JF (zone C7) are removed, the machine may not stop at the beginning of an instruction cycle.

### 3-33. RESET OPERATION

The reset operation allows the operator to reset the CPU at anytime during machine operation. The reset is activated when the RESET/EXT CLR switch on the front panel is positioned to RESET.

The reset circuits are located on the Display/Control card (Figure 3-16, sheet 2, zone A2). With the RESET/EXT CLR switch momentarily positioned to RESET, a PRESET signal (zone D3) is applied to the Interface (Figure 3-15, sheet 2, zone D1) as a HIGH. The HIGH is inverted by R and applied to pin 75 (zone A1) of the bus through non-inverting bus driver N (zone B1). The CPU receives the  $\overline{\text{PRESET}}$  signal and inverts it twice through G and B (Figure 3-14, zone B6). The output of B is applied to the clock generator F  $\overline{\text{RESIN}}$  (reset in) input (zone B7), producing a RESET output to the 8080 (M).

### 3-34. PROTECT AND UNPROTECT OPERATION

The protect/unprotect operation either prevents any new data from being written into a particular region of memory (protect) or allows new data to be written into a particular region of memory (unprotect). The protect/unprotect operation is controlled by the positioning of the PROTECT/UNPROTECT switch on the front panel.

The protect/unprotect circuits are located on the Display/Control card (Figure 3-16, sheet 2, zone A1). With the PROTECT/UNPROTECT switch positioned to either PROTECT or UNPROTECT, a  $\overline{\text{PROTECT}}$  or  $\overline{\text{UNPROTECT}}$  signal (zone D3) is applied to the Interface as a LOW. The LOW is inverted by R (Figure 3-15, sheet 2, zone B6) and applied to pin 70 and 20 on the bus to condition the memory. These signals are used to set or reset the protect/unprotect circuits on the addressed memory board.

### 3-35. PROGRAMMABLE READ ONLY MEMORY (PROM) CIRCUIT

The PROM circuit on the Display/Control Card is used when one of the following operations is performed: Examine, Examine Next, Deposit, Deposit Next, Accumulator Display, Accumulator Load, Accumulator Input and Accumulator Output. Each of the functions requires a program operation that is stored in the PROM. Access to these programs is determined by the type of function to be performed. The PROM operation is similar for each function, therefore two functions are discussed in detail.

### 3-36. PROM BLOCK DIAGRAM (Figure 3-13)

The PROM circuit contains eight individual programs which are used in conjunction with the following switches: EXAMINE/EX NEXT, DEPOSIT/DEP NEXT, ACCUMULATOR DISPLAY/LOAD, and ACCUMULATOR INPUT/OUTPUT. Activating any of these switches produces a specific binary number on the RA4, RA5, RA6, and RA7 lines (MSBs) from the Switches and Decoding circuit. At the same time the RA4 through RA7 data is generated, a RESET signal is applied to the 4-Bit Counter, conditioning the RA0, RA1, RA2, and RA3 outputs (LSBs) to zero. The RA0-RA7 signals are applied to the PROM, and they represent an 8-bit starting address location. There are eight different starting address locations which correspond to the eight different front panel switch settings (refer to Table 3-2). Any of the eight different starting address locations are always even because of the resetting of the 4-Bit Counter.

The PROM circuit outputs a DATA OUT (RD0-RD7) signal, consisting of eight individual lines, to either the Control Latch or the non-inverting bus driver F. The DATA OUT is transferred to one of these two circuits by the status of the RA0 signal from the 4-Bit Counter. When the RA0 signal is LOW, representing a PROM even address, the Control Latch receives the data. The even addresses of the PROM contain data that is used to enable the Control Latch output lines (S1-S8). After the Control Latch receives the PROM data, a CLOCK signal increments the 4-Bit Counter to an odd PROM address location. During an odd PROM address cycle, the CPU will execute one machine cycle (assuming the S8 bit has been set in the Control Latch). If the cycle is a memory read cycle, an instruction

April, 1977  
3800b

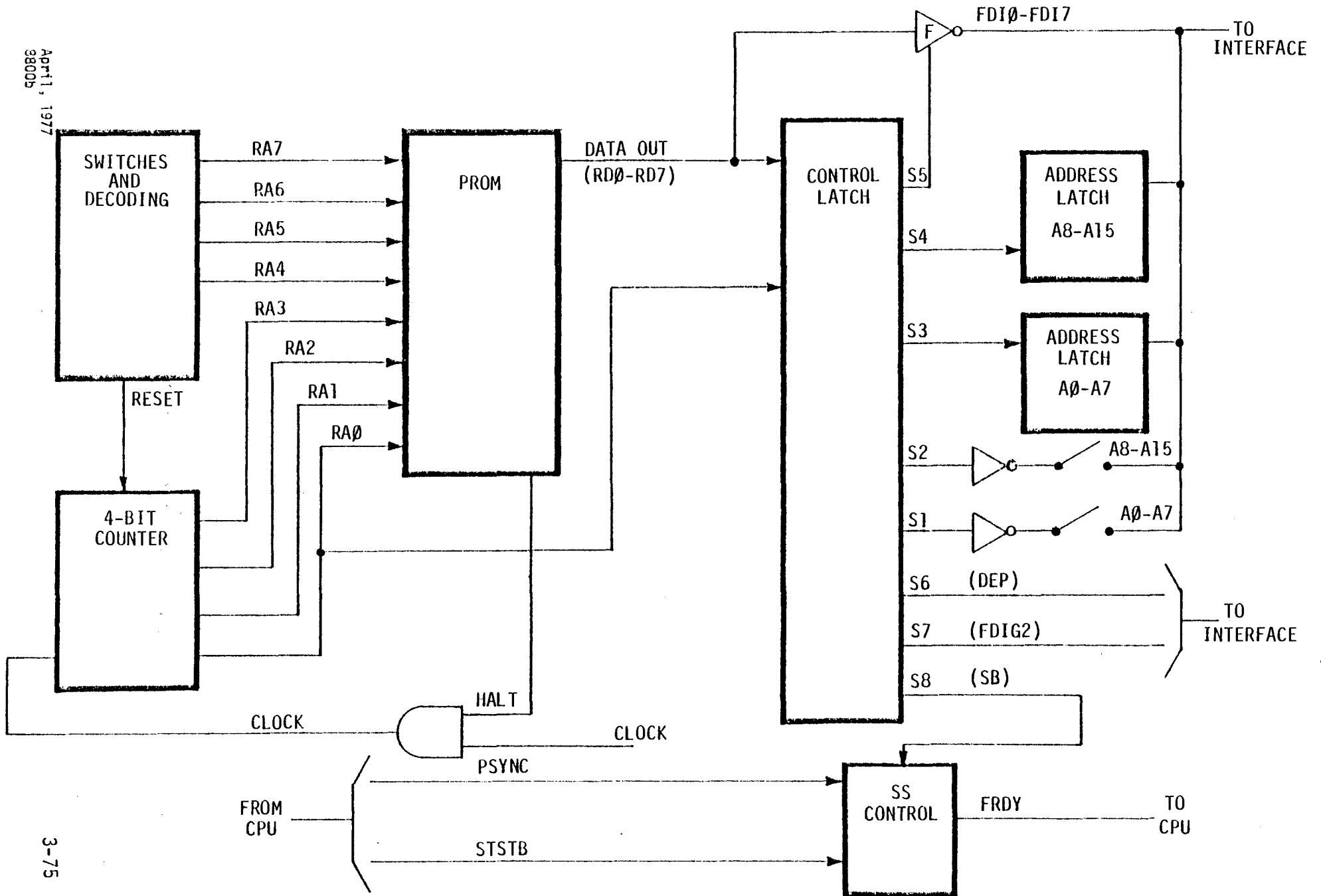

Figure 3-13. PROM Block Diagram



TABLE 3-2. PROM Programs

| Front Panel Operations | PROM Address | PROM DATA | Function                                      |
|------------------------|--------------|-----------|---|
| Examine                | 160*         | 013*      | Set S5, S7, S8                                |
|                        | 161          | 303       | Jam Jump Instruction to CPU                   |
|                        | 162          | 203       | Set S1, S7, S8                                |
|                        | 163          | 000       | Jam A0-A7 switch data to CPU                  |
|                        | 164          | 103       | Set S2, S7, S8                                |
|                        | 165          | 000       | Jam A8-A15 switch data to CPU                 |
|                        | 166          | 000       | Clear control latch                           |
|                        | 167          | 177       | Stop  |
| Examine Next           | 260          | 013       | Set S5, S7, S8                                |
|                        | 261          | 000       | Jam NOP instruction to CPU                    |
|                        | 262          | 000       | Clear control latch                           |
|                        | 263          | 177       | Stop  |
| Deposit                | 320          | 206       | Set S1, S6, S7                                |
|                        | 321          | 000       | Put A0-A7 switch data and MWRITE pulse on bus |
|                        | 322          | 000       | Clear control latch                           |
|                        | 323          | 177       | Stop  |
| Deposit Next           | 340          | 013       | Set S5, S7, S8                                |
|                        | 341          | 000       | Jam NOP instruction to CPU                    |
|                        | 342          | 206       | Set S1, S6, S7                                |
|                        | 343          | 000       | Put A0-A7 switch data and MWRITE pulse on bus |
|                        | 344          | 000       | Clear control latch                           |
|                        | 345          | 177       | Stop  |
| Display Accumulator    | 060          | 013       | Set S5, S7, S8                                |
|                        | 061          | 323       | Output Instruction                            |
|                        | 062          | 013       | Set S5, S7, S8                                |

\*All PROM address and data information is octal.

TABLE 3-2. PROM Programs - Continued

| Front Panel Operations   | PROM Address | PROM DATA | Function   |
|--|--------------|-----------|--|
|  | 063*         | 377*      | Jam front panel address to CPU                       |
|  | 064          | 001       | Set S8   |
|  | 065          | 000       | Data in accumulator is transferred to the D0-D7 LEDs |
|  | 066          | 013       | Set S5, S7, S8                                       |
|  | 067          | 303       | Jam jump instruction to CPU                          |
|  | 070          | 043       | Set S3, S7, S8                                       |
|  | 071          | 000       | Jam A0-A7 latch data to CPU                          |
|  | 072          | 023       | Set S4, S7, S8                                       |
|  | 073          | 000       | Jam A8-A15 latch data to CPU                         |
|  | 074          | 000       | Clear control latch                                  |
|  | 075          | 177       | Stop   |
| Accumulator Deposit  | 220          | 013       | Set S5, S7, S8                                       |
|  | 221          | 333       | Jam input instruction to CPU                         |
|  | 222          | 013       | Set S5, S7, S8                                       |
|  | 223          | 376       | Jam front panel address to CPU                       |
|  | 224          | 203       | Set S1, S7, S8                                       |
|  | 225          | 000       | Data in accumulator is transferred to CPU            |
|  | 226          | 013       | Set S5, S7, S8                                       |
|  | 227          | 303       | Jam jump instruction to CPU                          |
|  | 230          | 043       | Set S3, S7, S8                                       |
|  | 231          | 000       | Jam A0-A7 latch data to CPU                          |
|  | 232          | 023       | Set S4, S7, S8                                       |
|  | 233          | 000       | Jam A8-A15 latch data to CPU                         |
|  | 234          | 000       | Clear control latch                                  |
|  | 235          | 177       | Stop   |
| Input from external device selected by ADDRESS switches A8-A15 | 300          | 013       | Set S5, S7, S8                                       |
|  | 301          | 333       | Jam input instruction to CPU                         |
|  | 302          | 103       | Set S2, S7, S8                                       |
|  | 303          | 000       | Jam A8-A15 switch data to CPU                        |

\*All PROM address and data information is octal.

TABLE 3-2. PROM Programs - Continued

| Front Panel Operations  | PROM Address | PROM DATA | Function  |
|---|--------------|-----------|---|
|   | 304*         | 001*      | Set S8  |
|   | 305          | 000       | Data in accumulator is transferred to specific I/O device   |
|   | 306          | 013       | Set S5, S7, S8  |
|   | 307          | 303       | Jam jump instruction to CPU                                 |
|   | 310          | 043       | Set S3, S7, S8  |
|   | 311          | 000       | Jam A0-A7 latch data to CPU                                 |
|   | 312          | 023       | Set S4, S7, S8  |
|   | 313          | 000       | Jam A8-A15 latch data to CPU                                |
|   | 314          | 000       | Clear control latch   |
|   | 315          | 177       | Stop  |
| Output from external device selected by ADDRESS switches A8-A15 | 240          | 013       | Set S5, S7, S8  |
|   | 241          | 323       | Jam output instruction to CPU                               |
|   | 242          | 103       | Set S2, S7, S8  |
|   | 243          | 000       | Jam A8-A15 switch data to CPU                               |
|   | 244          | 001       | Set S8  |
|   | 245          | 000       | Data is transferred from specific I/O device to accumulator |
|   | 246          | 013       | Set S5, S7, S8  |
|   | 247          | 303       | Jam jump instruction to CPU                                 |
|   | 250          | 043       | Set S3, S7, S8  |
|   | 251          | 000       | Jam A0-A7 latch data to CPU                                 |
|   | 252          | 023       | Set S4, S7, S8  |
|   | 253          | 000       | Jam A8-A15 latch data to CPU                                |
|   | 254          | 000       | Clear control latch   |
|   | 255          | 177       | Stop  |

\*All PROM address and data information is octal.

byte is supplied to the CPU on the FDI $\emptyset$ -FDI7 lines.

The instruction data at the odd PROM address is transferred to the CPU through the Interface from five different sources. The source is determined by the output control lines S1 through S5 from the Control Latch.

The S1 and S2 control lines enable the front panel switch data, A $\emptyset$  through A15, to the Interface. The S3 and S4 control lines enable the Address Latch data, A $\emptyset$  through A15, to the Interface. The S5 control line enables the DATA OUT (RD $\emptyset$ -RD7) from the PROM to the Interface.

The data present at the Interface is applied to the CPU by output control lines S7 and S8 from the Control Latch. The S7 control line allows the Interface to apply the instruction data to the CPU, and the S8 control line enables the FRDY signal. The FRDY signal allows the CPU to receive the instruction data and execute one machine cycle. After the completion of the machine cycle, the PSYNC and STSTB signals from the CPU reset the SS Control circuit. The S6 control line is enabled from the Control Latch to allow data to be deposited into memory. Upon the completion of a PROM program, a HALT signal is generated by the PROM, disabling the CLOCK signal to the 4-Bit Counter.

### 3-37. EXAMINE OPERATION

The examine operation allows the operator to examine a memory location by using the ADDRESS switches on the front panel. Refer to Table 3-2 during the explanation. The examine operation is activated when the EXAMINE/EXAMINE NEXT switch is momentarily positioned to EXAMINE.

The EXAMINE circuit is located on the Display/Control card (Figure 3-16, sheet 2, zone B7). With the EXAMINE/EXAMINE NEXT switch momentarily positioned to EXAMINE, a LOW is generated at pin 6 of inverter V1 (zone B7) and a HIGH at the output of the remaining V1 and Z1 inverters (zones B6 through B3). The LOW output is applied to pin 6 of gate X1 which generates a HIGH to set L1 (zone D4). The  $\overline{RC-CLR}$  (LOW) and AL-STB (HIGH) outputs

from L1 reset a 4-bit binary counter to zero (sheet 2, zone A9) and strobes the current address data into data latches B1 and T1 (zone B6). The L1 latch is cleared by the  $\overline{C6}$  signal from the 24-bit binary counter (sheet 1, zone D3). The LOWs and HIGHs from the inverters are presented as RA7 through RA4 inputs to the PROM (sheet 1, zone B9).

The RA0 through RA7 inputs to the PROM (zone B9) represent an address location ( $160_g$ ). This location is the beginning of the examine program stored in the PROM. The data in address location  $160_g$  is presented on the RD0 through RD7 outputs ( $013_g$ ) and applied to data latch A (zone D8). After the 4-bit binary counter (zone B9) is LOW during the even addresses ( $RA0=0$ ), and a control strobe (CS) to DS2 (zone C8) is generated, the data present at latch A is stored by the A output.

The CS strobe is produced by the 24-bit counter outputs C6, C7, and  $\overline{C8}$  (zone D3). When the C6, C7, and  $\overline{C8}$  counter outputs are HIGH, NAND gate V (zone D5) is enabled LOW, and CS (zone D6) is applied HIGH to the DS2 input of data latch A (zone C8). With DS2 and  $\overline{DST}$  enabled, the RD0 through RD7 data ( $013_g$ ) is latched into A. The  $013_g$  data enables outputs S5, S7, and S8 (zone D7) HIGH. Output S5 is inverted LOW by A1 (zone A6), enabling inverting bus drivers R and S. Outputs S7 and S8 are applied to pins 3 and 13 of NAND gates J (zone D6). With the PROM data stored in latch A and the associated circuits conditioned, NAND gate Z (zone A7) produces a clock pulse to INP A of the 4-bit counter (zone A8). When C8 goes HIGH from the 24-bit counter (zone D3), the 4-bit counter, A output, goes HIGH which addresses PROM location  $161_g$ .

The data in address location  $161_g$  is present on the RD0 through RD7 outputs  $303_g$ . The  $303_g$  data is transferred to the Interface on the FDI0-FDI7 (zone C2) outputs through enabled inverting bus drivers R and S (zone A6). The data is not stored in Latch A because the A output (zone B9) of the 4-bit counter is HIGH (odd address  $RA0=1$ ), disabling the  $\overline{DST}$  input (zone C7). The A output is applied to pins 1 and 5 of NAND gates J (zone D6).

The  $\overline{FDI0}$  through  $\overline{FDI7}$  data presented to the Interface Card (Figure 3-15, sheet 2, zone D8) represents a jump instruction to be stored in the CPU. The CPU cannot receive this instruction and execute it until the  $\overline{FDIG2}$  (zone D7) signal is LOW, and the CPU is released from the wait condition generated when the CPU was stopped. The following operation allows the CPU to receive the jump instruction.

When the C6, C7, and  $\overline{C8}$  outputs of the 24-bit counter on the Display/Control (Figure 3-16, sheet 1, zone D3) are HIGH, another CS signal (zone D6) is generated. The CS signal allows NAND gate J, pins 6 and 12, to produce  $\overline{SB}$  (zone D4) and  $\overline{FDIG2}$  (zone C2) signals.

The  $\overline{SB}$  signal is applied to pin 13 of gate D1 (sheet 2, zone C8) as a LOW, producing a HIGH clock pulse to set M1 (zone C7). The  $\overline{Q}$  output of M1 is applied to pin 13 of NOR gate P1 and inverter R1 (zone D9), allowing the  $\overline{FRDY}$  signal to release the CPU from its wait condition.

The  $\overline{FDIG2}$  signal is applied to pin 12 of NOR gate B (Figure 3-15, sheet 2, zone C7) on the Interface as a LOW which enables NAND gate B, pin 6, LOW (PDBIN is HIGH because the CPU is in a wait condition). The LOW enables the non-inverting drivers F (zone B7), allowing the PROM data ( $303_8$ ) to be applied to M on the CPU through bi-directional gates D and E on the CPU (Figure 3-14, zone C7). Because the READY line to M (zone A8) is HIGH, the CPU inputs the  $303_8$  data which is interpreted by the CPU as a jump instruction. After the completion of the machine cycle, the  $\overline{PSYNC}$  and  $\overline{D05}$  signals (sheet 2, zone D8) are inverted by R1 and applied to pins 11 and 10 of NAND gate T1 (zone D6). These signals and  $\overline{SB}$  (zone D8) enable T1 which generates a clear to M1 (zone C7), halting the CPU.

The CPU contains a jump instruction but no information as to where to jump. The remaining part of the examine operation allows the ADDRESS switch data to be read into the CPU from the front panel in order for the CPU to jump to that address. NAND gate Z (sheet 1, zone A7) produces another clock pulse to INP A of the 4-bit counter. When C8 goes HIGH and returns LOW (zone D3), the 4-bit counter increments to an even PROM address  $162_8$ .

The data in address location  $162_8$  is present on the  $RD_0$  through  $RD_7$  outputs ( $203_8$ ) and applied to data latch A (zone D8). The data present at latch A is stored by the LOW A output (zone B9) during even addresses ( $RA_0=0$ ) and the generation of the CS strobe ( $C_6$ ,  $C_7$ , and  $\overline{C_8}$  HIGH). The  $203_8$  data enables outputs  $S_1$ ,  $S_7$ , and  $S_8$  (zone D7) HIGH. Output  $S_1$  is applied through inverters Y and W (zone C4) to the  $A_0$  through  $A_7$  switches (open switch HIGH, closed switch LOW), and the switch information is presented to the Interface as  $\overline{FDI_0}$  through  $\overline{FDI_7}$ . Outputs  $S_7$  and  $S_8$  are applied to pins 3 and 13 of NAND gate J (zone D6) and are used to generate the  $\overline{FDIG_2}$  and  $\overline{SB}$  signals as described in the jump instruction transfer. With the data presented to the Interface Card and the associated circuits conditioned, NAND gate (zone A7) is enabled ( $C_8$  HIGH), producing a clock pulse to INP A, incrementing the 4-bit counter (zone A8) to address  $163_8$ .

The data in address  $163_8$  is not stored in latch A because it is an odd address. However, the A output (zone B9) is applied to pins 1 and 5 of NAND gates J (zone D6) as a HIGH, allowing the CS signal to produce the  $\overline{SB}$  and  $\overline{FDIG_2}$  outputs. The  $\overline{SB}$  and  $\overline{FDIG_2}$  signals allow the transfer of the first eight address data bits (address switches  $A_0$ - $A_7$ ) to the CPU, and the operation is identical to the jump instruction.

After the CPU receives the eight address bits, the 4-bit binary counter is incremented to address  $164_8$ . The data in  $164_8$  ( $01000110 - 103_8$ ) is stored in latch A (zone D7) because it is an even address. The  $103_8$  data enables  $S_2$ ,  $S_7$ , and  $S_8$  (zone D7) HIGH. Output  $S_2$  is applied to inverter A1 (zone C6), gate Z (zone C5), and inverters W and U (zone C4) to the  $A_8$  through  $A_{15}$  address switches. The switch information is presented to the Interface as  $\overline{FDI_0}$  through  $\overline{FDI_7}$ . Outputs  $S_7$  and  $S_8$  condition NAND gates J (zone D6) and are used to generate  $\overline{SB}$  and  $\overline{FDIG_2}$  during the next address. With the data present to the Interface and the associated circuits conditioned, NAND gate Z (zone A7) is enabled ( $C_8$  HIGH), producing a clock pulse to INP A, incrementing the 4-bit counter (zone A8) to address  $165_8$ .

Address  $165_8$  operation is the same as address  $163_8$ , allowing the  $A_8$  through  $A_{15}$  address data to be stored in the CPU. After

the CPU receives the second byte of the address, it executes a jump to that address. Address  $166_8$  clears the data latch A (zone D7) and allows the CPU to address memory (Figure 3-14, zone B9). The memory presents the addressed memory location data to the CPU via data input lines DI $\emptyset$  through DI7 (zone B1). The data is enabled through inverters Y, S, L, and J (zone B4) and non-inverters P, W (zone C3) to the Interface (Figure 3-15, sheet 1, zone B1). The data is enabled through the G data latch (sheet 3, zone B4) to the Display/Control (Figure 3-16, sheet 3, zone D1) and displayed on the LEDs. The G latch (sheet 3, zone B4) is enabled because the  $\overline{\text{RUN}}$  signal (zone A6) is HIGH, producing a HIGH at input MD of the data latch.

While the memory data was being displayed, the 4-bit binary counter (Figure 3-16, sheet 1, zone A9) is incremented to address  $167_8$ . The data in  $167_8$  (01111111 -  $177_8$ ) is applied to NAND gate N (zone B7), producing a HIGH at gate Z (zone B8). The HIGH at gate Z disables NAND gate Z (zone A8), inhibiting any following clock pulses to the 4-bit binary counter, thus ending the examine operation.

### 3-38. ACCUMULATOR DISPLAY OPERATION

The accumulator (ACC) display operation allows the operator to monitor the contents of the CPU accumulator. Refer to Table 3-1, PROM Programs, during the explanation. The ACC display operation is activated when the ACC DISPLAY/ACC DEPOSIT switch is momentarily positioned to ACC DISPLAY.

The ACC DISPLAY circuit is located on the Display/Control card (Figure 3-16, sheet 2, zone A5). With the ACC DISPLAY/ACC DEPOSIT switch momentarily positioned to ACC DISPLAY, a LOW is generated at pins 8 and 10 of inverter V1 (zone B5), and a HIGH is generated at the output of the remaining V1 and Z1 inverters (zones B7 through B3). The LOW outputs are applied to pins 6 and 5 of gate X1 which generates a HIGH to set L1 (zone D4). The  $\overline{\text{RC-CLR}}$  (LOW) and AL-STB (HIGH) outputs from L1 reset a 4-bit binary counter to all zeros (sheet 1, zone A9) and strobe the address in the P counter into data latches B1 and T (zone B6). The P counter address data is stored because the P counter increments during the accumulator display operation. The original P



count is saved and restored in the CPU after the ACC display operation is complete. The L1 latch is cleared by the  $\overline{C6}$  signal from the 24-bit binary counter (sheet 1, zone D3). The LOW and HIGHs from the inverters are presented as RA7 through RA4 inputs to the PROM (sheet 1, zone B9). An  $\overline{ACC\ DSP}$  signal (zone D3) is also applied LOW to the Interface (Figure 3-15, sheet 3, zone A1), producing a LOW to the MD input of data latch G (zone A4).

The RA0 through RA7 inputs to the PROM (zone B9) represent an address location ( $060_8$ ). This location is the beginning of the ACC display program stored in the PROM. The data in address location  $060_8$  is presented on the RD0 through RD7 outputs ( $013_8$ ) and applied to data latch A (zone D8). The data present at latch A is stored by the LOW A output (zone B9) during the even addresses ( $RA0=0$ ) and the generation of a control strobe (CS) to DS2 (zone C8).

The CS strobe is produced by the 24-bit counter outputs C6, C7, and  $\overline{C8}$  (zone D3). When the C6, C7, and  $\overline{C8}$  counter outputs are HIGH, NAND gate V (zone D5) is enabled LOW, the CS (zone D6) is applied HIGH to the DS2 input (zone C8). The RD0 through RD7 data ( $013_8$ ) is latched into A with DS2 and  $\overline{DST}$  enabled. The  $013_8$  data enables outputs S5, S7, and S8 (zone D7) HIGH. Output S5 is inverted LOW by A1 (zone A6), enabling inverting bus drivers R and S. Outputs S7 and S8 are applied to pins 3 and 13 of NAND gates J (zone D6). With the PROM data stored in latch A and the associated circuits conditioned, NAND gate Z (zone A7) is enabled, producing a clock pulse to INP A of the 4-bit counter (zone A8). When C8 goes HIGH from the 24-bit counter (zone D3), the 4-bit counter A output goes HIGH which addresses PROM location  $061_8$ .

The data in address location  $061_8$  is present on the RD0 through RD7 outputs ( $323_8$ ). The  $323_8$  data is transferred to the Interface on the  $\overline{FDI0}$ - $\overline{FDI7}$  (zone C2) outputs through enabled inverting bus drivers R and S (zone A6). The data is not stored in latch A because the A output (zone B9) of the 4-bit counter is HIGH (odd address), disabling the  $\overline{DST}$  input (zone C7). The A output is applied to pins 1 and 5 of NAND gates J (zone D6).

The  $\overline{FDI0}$  through  $\overline{FDI7}$  data presented to the Interface (Figure 3-15, sheet 2, zone D8) represents an output instruction to be stored in the CPU. The CPU cannot receive this instruction and

execute it until the  $\overline{\text{FDIG2}}$  (zone D7) signal is LOW, and the CPU is released from the wait condition generated when the CPU was stopped. The following operation allows the CPU to receive the output instruction.

When the C6, C7, and  $\overline{\text{C8}}$  outputs of the 24-bit counter on the Display/Control (Figure 3-16, sheet 1, zone D3) are HIGH, another CS signal (zone D6) is generated. The CS signal allows NAND gate J, pins 6 and 12, to produce a  $\overline{\text{FDIG2}}$  (zone C2) and  $\overline{\text{SB}}$  (zone D4) signal.

The  $\overline{\text{SB}}$  signal is applied to pin 13 of gate D1 (sheet 2, zone C8) as a LOW which produces a HIGH clock pulse to set M1 (zone C7). The  $\overline{\text{Q}}$  output of M1 is applied to gate P1 and inverter R1 (zone D9), allowing the  $\overline{\text{FRDY}}$  signal to release the CPU from its wait condition.

The  $\overline{\text{FDIG2}}$  signal is applied to pin 12 of gate 13 (Figure 3-15, sheet 2, zone C7) as a LOW which enables NAND gate B, pin 6, LOW. The LOW allows the PROM data ( $323_{\text{g}}$ ) to be applied to M on the CPU through bi-directional gates D and E on the CPU (Figure 3-14, zone C7). Because the READY line to M (zone A8) is HIGH, the CPU inputs the  $323_{\text{g}}$  data which is interpreted as an output instruction. After the completion of the machine cycle, the  $\overline{\text{PSYNC}}$  and  $\overline{\text{D05}}$  signals (Figure 3-14, sheet 2, zone D8) are inverted by R1 and applied to pins 11 and 10 of NAND gate T1 (zone D6). These signals and  $\overline{\text{SB}}$  (zone D8) enable T1 which generates a clear to M1 (zone C7), halting the CPU.

The CPU contains an output instruction but no information as to where to output data. The next part of the ACC display operation allows the CPU to output data to the front panel data LEDs (D0 through D7). NAND gate Z (sheet 1, zone A7) is enabled (C8 HIGH), producing a clock pulse to INP A, incrementing 4-bit counter (zone A8) to address  $062_{\text{g}}$ .

The data in address location  $062_{\text{g}}$  is present on the RD0 through RD7 outputs ( $013_{\text{g}}$ ) and stored in data latch A (zone D8) in the same manner as address  $060_{\text{g}}$ . This insures that the S5, S7, and S8 outputs (zone D7) are enabled as in address  $060_{\text{g}}$ . After the completion of this operation, NAND gate Z (zone A7) is enabled, producing a clock pulse to INP A, incrementing the 4-bit counter

(zone A8) to address  $063_g$ .

The data in address location  $063_g$  is present on the  $RD_0$  through  $RD_7$  outputs ( $377_g$ ) which is the I/O channel number for the front panel. The  $377_g$  data is transferred to the CPU in the same manner as the output instruction at address  $061_g$ . The  $377_g$  data allows the CPU to address the front panel and output the accumulator data to the  $D_0$  through  $D_7$  LEDs on the front panel. With the output instruction and front panel address number stored in the CPU, NAND gate Z (zone B7) is enabled, producing a clock pulse to INP A, incrementing the 4-bit binary counter (zone A8) to address  $064_g$ .

The data in address location  $064_g$  is present to the  $RD_0$  through  $RD_7$  outputs ( $001_g$ ) and stored in data latch A (zone D8). The  $001_g$  data enables output S8 (zone D7) HIGH which is used during address  $065_g$ . After the data in address location  $064_g$  is stored in data latch A, NAND gate Z (zone B7) is enabled, producing a clock pulse to INP A, incrementing the 4-bit binary counter (zone A8) to address  $065_g$ .

Address  $065_g$  enables the  $\overline{SB}$  signal (zone D4) as described in address  $061_g$ . The CPU performs one machine cycle with  $\overline{SB}$  enabled. During the one machine cycle, the CPU outputs address  $377_g$  on the  $A_0 - A_7$  and  $A_8 - A_{15}$  address lines to the bus (Figure 3-14, zone B9). The CPU also outputs accumulator data through bi-directional gates D and E (zone C7) and non-inverting bus drivers P and W (zone C3) to the data out ( $D_{00} - D_{07}$ ) bus. The address data ( $377_g$ ) enables NAND gates L on the Interface board (Figure 3-15, sheet 3, zone C6) LOW. The LOWs enable gate D (zone C4) HIGH which is applied through jumper JE/JF to pin 9 of NAND gate K (zone B4). During an output instruction, the  $\overline{SOUT}$  and PWR signals (zone B6) are generated by the CPU which enables NAND gate K (zone B4) output LOW. The LOW is applied through jumper JD/JC and inverted HIGH by gate J (zone C3) and presented to the STB input (zone B4) of latch G.

The data from the CPU is presented to the Interface (sheet 1, zone C1) and stored in data latch G (sheet 3, zone B4) during the output instruction because the STB and MD inputs are enabled.

The outputs of data latch G light the appropriate data LED (D0-D7) on the Display/Control Panel (Figure 3-16, sheet 3, zone D2). After the machine cycle is complete, NAND gate Z (sheet 1, zone B7) is enabled, producing a clock pulse to INP A, incrementing the 4-bit binary counter to address  $066_8$ .

The data ( $013_8$ ) in address location  $066_8$  is stored in data latch A (zone D8) and enables the S5, S7, and S8 outputs (zone D7) HIGH. After the completion of this operation, NAND gate Z is enabled, and the 4-bit binary counter is incremented to address  $067_8$ . Address  $067_8$  contains a jump instruction ( $303_8$ ) which is stored in the CPU in the same manner as the previous instructions. The jump instruction will force the CPU back to the original P counter address which was stored in data latches B1 and T (zone B5) at the beginning of the ACC display operation. The remainder of the ACC display operation will transfer the address stored (A0-A7) in B1 and (A8-A15) in T to the CPU. After the jump instruction is stored in the CPU, the 4-bit binary counter is incremented to address  $070_8$ .

The data in address location  $070_8$  is present on the RD0 through RD7 outputs ( $043_8$ ) and applied to data latch A (zone D8). The data present at latch A is stored by the A output of the 4-bit binary counter (zone B9) being LOW during even addresses and the generation of the CS strobe (C6, C7, and  $\overline{C8}$  HIGH). The  $043_8$  data enables outputs S3, S7, and S8 (zone D7) HIGH. Output S3 is applied to the DS2 input of data latch B1 (zone C5), presenting the output data (A0-A7) to the Interface as  $\overline{FDI0}$  through  $\overline{FDI7}$ . Outputs S7 and S8 are applied to pins 3 and 13 of NAND gate J (zone D6) and are used to generate the  $\overline{SB}$  and  $\overline{FDIG2}$  signals as described in the previous instruction transfers. With the data present to the Interface and the associated circuits conditioned, NAND gate Z (zone A7) is enabled, producing a clock pulse to INP A, incrementing the 4-bit counter (zone A8) to address  $071_8$ .

The data in address  $071_8$  is not stored in latch A because it is an odd address. However, the A output (zone B9) is applied to pins 1 and 5 of NAND gates J (zone D6) as a HIGH, enabling the CS signal to produce the  $\overline{SB}$  and  $\overline{FDIG2}$  outputs. The  $\overline{SB}$  and  $\overline{FDIG2}$  signals allow the transfer of the first eight address data latch

bits to the CPU, and the operation is identical to the previous instructions.

After the CPU receives the eight address bits, the 4-bit binary counter increments to address  $072_8$ . The data in  $072_8$  ( $023_8$ ) is stored in latch A (zone D7) because it is an even address. The  $023_8$  data enables S4, S7, and S8 (zone D7) HIGH. Output S4 is applied to the DS2 input of data latch T (zone A6), presenting the output data (A8-A15) to the Interface as  $\overline{FDI0}$  through  $\overline{FDI7}$ . Outputs S7 and S8 condition NAND gates J (zone D6) and are used to generate  $\overline{SB}$  and  $\overline{FDIG2}$  during the next address ( $073_8$ ). With the data present to the Interface and the associated circuits conditioned, NAND gate Z (zone A7) is enabled (C8 HIGH), producing a clock pulse to INP A, incrementing the 4-bit counter (zone A8) to address  $073_8$ .

Address  $073_8$  operation is the same as address  $071_8$ , allowing the A8 through A15 address data to be stored in the CPU. Address  $074_8$  clears the data latch A (zone D7) and allows the CPU to jump to the original P counter address, conditioning the CPU for normal operation.

After conditioning the CPU, the 4-bit binary counter (zone A9) is incremented to address  $075_8$ . The data in  $075_8$  ( $177_8$ ) is applied to NAND gate N (zone B7), producing a HIGH at gate Z (zone B8). The HIGH at gate Z disables NAND gate Z (zone A8), inhibiting any following clock pulses to the 4-bit binary counter, thus ending the ACC display operation.

### 3-39. 8800b OPTIONS

The 8800b has several options which may be selected by the operator. Two options may be used on the Display/Control card, and three options may be used on the Interface card.

### 3-40. DISPLAY/CONTROL CARD OPTIONS

The Display/Control card options contain a choice of front panel slow operation clock frequencies and a choice of completing one instruction cycle or machine cycle in single step or slow operation. The normal slow operation clock frequency requires a

connection between jumpers JA and JD (Figure 3-16, sheet 1, zone D2). For slower operation, jumpers JB to JD or JC to JD may be connected. The normal single/step or slow operation requires a connection between jumpers JE and JF (sheet 2, zone D7) which allows the 8800b CPU to complete one instruction cycle before resuming a wait condition. However, if the operator wishes to execute one machine cycle after each single/step or slow operation, remove jumpers JE and JF which disables the  $\overline{D05}$  signal (zone D8).

### 3-41. INTERFACE CARD OPTIONS

One Interface Card option allows the operator to monitor any data from an external device on the D0 through D7 front panel LEDs. Data may be monitored from an external device if jumpers JA and JB are connected (Figure 3-15, sheet 3, zone C3). NAND gate K is enabled LOW when the  $\phi 1$ ,  $\overline{PDBIN}$ , and  $\overline{SINP}$  signals (zone C6) are present during an external device to CPU data transfer. The LOW is presented through JB and JA (zone C3) to gate J which produces a HIGH to the STB input of data latch G (zone B4). The HIGH on STB allows the data present on the D00-D07 line (zone B6) to be displayed on the D0-D7 LEDs on the front panel.

The remaining Interface card options pertain to jumpers JE and JF (zone C4) and jumpers JD and JC (zone C3). If jumpers JE and JF and JC and JD are connected, only data addressed to the front panel (377<sub>g</sub>) is displayed. If jumpers JE and JF are removed, all output data from the CPU is displayed on the front panel.

### 3-42. 8800b POWER SUPPLIES

The 8800b requires a positive 8 volt, 18 ampere supply, a positive 18 volt, 2 ampere supply, and a -18 volt, 2 ampere supply (Figure 3-17). When the ON/OFF switch on the front panel is positioned to ON, a 110 AC voltage is applied to transformer T1. Two bridge rectifiers on the secondary of T1 produce the positive 8, 18, and negative 18 voltage supplies which are applied to the 8800b circuits. The positive and negative 18 volt supplies are pre-regulated by the Q1 and Q2 transistor circuits on the power supply board.

The 8800b printed circuit cards receive the supply voltages on the bus. Each printed circuit card contains its own voltage regulator circuits which produce the operating voltage for the particular printed circuit card.

The CPU card (Figure 3-18) requires a regulated positive and negative 5 volt source and a regulated positive 12 volt source. These voltages are produced by VR1, VR2, and D2 circuits.

The Interface card (Figure 3-19) requires a regulated positive 5 volt source which is produced by the VR1 circuit.

The Display/Control card (Figure 3-20) requires an unregulated positive 8 volt source, a regulated positive 5 volt source, and a regulated negative 9 volt source. The regulated voltages are produced by the VR1 and VR2 circuits.

Table 3-3. Bus Definitions

| <u>PIN NUMBER</u> | <u>SYMBOL</u>   | <u>NAME</u>                    | <u>FUNCTION</u>  |
|-------------------|-----------------|--------------------------------|--|
| 1                 | +8v             | +8 volts                       | Unregulated voltage on bus, supplied to PC boards and regulated to 5v.     |
| 2                 | +18v            | +18 volts                      | Positive pre-regulated voltage.  |
| 3                 | XRDY            | EXTERNAL READY                 | External ready input to CPU board's ready circuitry                        |
| 4                 | VI0             | Vectored Interrupt Line #0     |  |
| 5                 | VI1             | Vectored Interrupt Line #1     |  |
| 6                 | VI2             | Vectored Interrupt Line #2     |  |
| 7                 | VI3             | Vectored Interrupt Line #3     |  |
| 8                 | VI4             | Vectored Interrupt Line #4     |  |
| 9                 | VI5             | Vectored Interrupt Line #5     |  |
| 10                | VI6             | Vectored Interrupt Line #6     |  |
| 11                | VI7             | Vectored Interrupt Line #7     |  |
| 12                | *XRDY2          | EXTERNAL READY #2              | A second external ready line similar to XRDY                               |
| 13<br>to<br>17    | To be defined   |                                |  |
| 18                | <u>STAT DSB</u> | <u>STATUS DISABLE</u>          | Allows the buffers for the 8 status lines to be tri-stated                 |
| 19                | <u>C/C DSB</u>  | <u>COMMAND/CONTROL DISABLE</u> | Allows the buffers for the 6 output command/control lines to be tri-stated |
| 20                | UNPROT          | UNPROTECT                      | Input to the memory protect flip-flop on a given memory board              |

\*New bus signal for 8800b.



| <u>PIN<br/>NUMBER</u> | <u>SYMBOL</u>  | <u>NAME</u>             | <u>FUNCTION</u>   |
|-----------------------|----------------|-------------------------|---|
| 21                    | 55             | SINGLE STEP             | Indicates that the machine is in the process of performing a single step (i.e. that SS flip-flop on D/C is set)   |
| 22                    | <u>ADD DSB</u> | <u>ADDRESS DISABLE</u>  | Allows the buffers for the 16 address lines to be tri-stated  |
| 23                    | <u>DO DBS</u>  | <u>DATA OUT DISABLE</u> | Allows the buffers for the 8 data output lines to be tri-stated   |
| 24                    | Ø2             | PHASE 2 CLOCK           |   |
| 25                    | Ø1             | PHASE 1 CLOCK           |   |
| 26                    | PHLDA          | HOLD ACKNOWLEDGE        | Processor command/control output signal that appears in response to the HOLD signal; indicates that the data and address bus will go to the high impedance state and processor will enter HOLD state after completion of the current machine cycle  |
| 27                    | PWAIT          | WAIT                    | Processor command/control signal that appears in response to the READY signal going low; indicates processor will enter a series of .5 microsecond WAIT states until READY again goes high.   |
| 28                    | PINTE          | INTERRUPT ENABLE        | Processor command/control output signal; indicates interrupts are enabled, as determined by the contents of the CPU internal interrupt flip-flop. When the flip-flop is set (Enable Interrupt instruction), interrupts are accepted by the CPU; when it is reset (Disable Interrupt instruction), interrupts are inhibited. |
| 29                    | A5             | Address Line #5         |   |
| 30                    | A4             | Address Line #4         |   |

| <u>PIN<br/>NUMBER</u> | <u>SYMBOL</u>      | <u>NAME</u>        | <u>FUNCTION</u>   |
|-----------------------|--------------------|--------------------|---|
| 31                    | A3                 | Address Line #3    |   |
| 32                    | A15                | Address Line #15   | (MSB)   |
| 33                    | A12                | Address Line #12   |   |
| 34                    | A9                 | Address Line #9    |   |
| 35                    | D01                | Data Out Line #1   |   |
| 36                    | D00                | Data Out Line #0   | (LSB)   |
| 37                    | A10                | Address Line #10   |   |
| 38                    | D04                | Data Out Line #4   |   |
| 39                    | D05                | Data Out Line #5   |   |
| 40                    | D06                | Data Out Line #6   |   |
| 41                    | DI2                | Data In Line #2    |   |
| 42                    | DI3                | Data In Line #3    |   |
| 43                    | DI7                | Data In Line #7    | (MSB)   |
| 44                    | SM1                | MACHINE CYCLE 1    | Status output signal that indicates that the processor is in the fetch cycle for the first byte of an instruction   |
| 45                    | SOUT               | OUTPUT             | Status output signal that indicates the address bus contains the address of an output device and the data bus will contain the output data when $\overline{PWR}$ is active        |
| 46                    | SINP               | INPUT              | Status output signal that indicates the address bus contains the address of an input device and the input data should be placed on the data bus when $\overline{PDBIN}$ is active |
| 47                    | SMEMR              | MEMORY READ        | Status output signal that indicates the data bus will be used to read memory data   |
| 48                    | SHLTA              | HALT               | Status output signal that acknowledges a HALT instruction   |
| 49                    | $\overline{CLOCK}$ | $\overline{CLOCK}$ | Inverted output of the $\emptyset 2$ CLOCK  |

| <u>PIN<br/>NUMBER</u> | <u>SYMBOL</u>  | <u>NAME</u>               | <u>FUNCTION</u>   |
|-----------------------|----------------|---------------------------|---|
| 50                    | GND            | GROUND                    |   |
| 51                    | +8v            | +8 volts                  | Unregulated input to 5<br>volt regulators   |
| 52                    | -18v           | -18 volts                 | Negative pre-regulated<br>voltage   |
| 53                    | <u>SSWI</u>    | <u>SENSE SWITCH INPUT</u> | Indicates that an input<br>data transfer from the<br>sense switches is to take<br>place. This signal is<br>used by the Display/<br>Control logic to:<br>a) Enable sense switch<br>drivers<br>b) Enable the Display/<br>Control board drivers<br>Data Input (FDI0-FDI7)<br>c) Disable the CPU board<br>Data Input Drivers<br>(DI0-DI7) |
| 54                    | <u>EXT CLR</u> | <u>EXTERNAL CLEAR</u>     | Clear signal for I/O<br>devices (front panel<br>switch closure to ground)   |
| 55                    | *RTC           | REAL TIME CLOCK           | 60Hz signal used as timing<br>reference by the Real<br>Time Clock/Vectored Inter-<br>rupt Board   |
| 56                    | * <u>STSTB</u> | <u>STATUS STROBE</u>      | Output strobe signal sup-<br>plied by the 8224 clock<br>generator. Primary pur-<br>pose is to strobe the 8212<br>status latch so that status<br>is set up as soon in the<br>machine cycle as possible.<br>This signal is also used<br>by Display/Control logic.   |
| 57                    | *DIG1          | DATA INPUT GATE #1        | Output signal from the<br>Display/Control logic that<br>determines which set of<br>Data Input Drivers have<br>control of the CPU board's<br>bidirectional data bus.<br>If DIG1 is HIGH, the CPU<br>drivers have control; if<br>it is LOW the Display/<br>Control logic drivers have<br>control.                                       |

| <u>PIN<br/>NUMBER</u> | <u>SYMBOL</u>    | <u>NAME</u>              | <u>FUNCTION</u>  |
|-----------------------|------------------|--------------------------|--|
| 58                    | *FRDY            | FRONT PANEL READY        | Output signal from D/C logic that allows the front panel to control the READY line to the CPU  |
| 59<br>to<br>67        | TO BE<br>DEFINED |                          |  |
| 68                    | MWRITE           | MEMORY WRITE             | Indicates that the data present on the Data Out Bus is to be written into the memory location currently on the address bus   |
| 69                    | <u>PS</u>        | <u>PROTECT STATUS</u>    | Indicates the status of the memory protect flip-flop on the memory board currently addressed   |
| 70                    | PROT             | PROTECT                  | Input to the memory protect flip-flop on the memory board currently addressed  |
| 71                    | RUN              | RUN                      | Indicates that the STOP/RUN flip-flop is Reset; i.e. machine is in RUN mode  |
| 72                    | PRDY             | PROCESSOR READY          | Memory and I/O input to the CPU board wait circuitry   |
| 73                    | <u>PINT</u>      | <u>INTERRUPT REQUEST</u> | The processor recognizes an interrupt request on this line at the end of the current instruction or while halted. If the processor is in the HOLD state or the Interrupt Enable flip-flop is reset, it will not honor the request.                       |
| 74                    | <u>PHOLD</u>     | <u>HOLD</u>              | Processor command/control input signal that requests the processor enter the HOLD state; allows an external device to gain control of address and data buses as soon as the processor has completed its use of these buses for the current machine cycle |

\*New bus signal for 88Q0b.

| <u>PIN<br/>NUMBER</u> | <u>SYMBOL</u> | <u>NAME</u>           | <u>FUNCTION</u>  |
|-----------------------|---------------|-----------------------|--|
| 75                    | <u>PRESET</u> | <u>RESET</u>          | Processor command/control input; while activated, the content of the program counter is cleared and the instruction register is set to 0     |
| 76                    | PSYNC         | SYNC                  | Processor command/control output; provides a signal to indicate the beginning of each machine cycle  |
| 77                    | <u>PWR</u>    | <u>WRITE</u>          | Processor command/control output; used for memory write or I/O output control. Data on the data bus is stable while the <u>PWR</u> is active |
| 78                    | PDBIN         | DATA BUS IN           | Processor command/control output; indicates to external circuits that the data bus is in the input mode                                      |
| 79                    | A0            | Address Line #0       | (LSB)  |
| 80                    | A1            | Address Line #1       |  |
| 81                    | A2            | Address Line #2       |  |
| 82                    | A6            | Address Line #6       |  |
| 83                    | A7            | Address Line #7       |  |
| 84                    | A8            | Address Line #8       |  |
| 85                    | A13           | Address Line #13      |  |
| 86                    | A14           | Address Line #14      |  |
| 87                    | A11           | Address Line #11      |  |
| 88                    | D02           | Data Out Line #2      |  |
| 89                    | D03           | Data Out Line #3      |  |
| 90                    | D07           | Data Out Line #7      |  |
| 91                    | DI4           | Data In Line #4       |  |
| 92                    | DI5           | Data In Line #5       |  |
| 93                    | DI6           | Data In Line #6       |  |
| 94                    | DI1           | Data In Line #1       |  |
| 95                    | DIO           | Data In Line #0       | (LSB)  |
| 96                    | SINTA         | INTERRUPT ACKNOWLEDGE | Status output signal; acknowledges signal for INTERRUPT request  |

| <u>PIN<br/>NUMBER</u> | <u>SYMBOL</u> | <u>NAME</u>           | <u>FUNCTION</u>  |
|-----------------------|---------------|-----------------------|--|
| 97                    | <u>SWO</u>    | <u>WRITE OUT</u>      | Status output signal;<br>indicates that the oper-<br>ation in the current<br>machine cycle will be a<br>WRITE memory or output<br>function |
| 98                    | SSTACK        | STACK                 | Status output signal<br>indicates that the address<br>bus holds the pushdown<br>stack address from the<br>Stack Pointer                    |
| 99                    | <u>POC</u>    | <u>POWER-ON CLEAR</u> |  |
| 100                   | GND           | GROUND                |  |

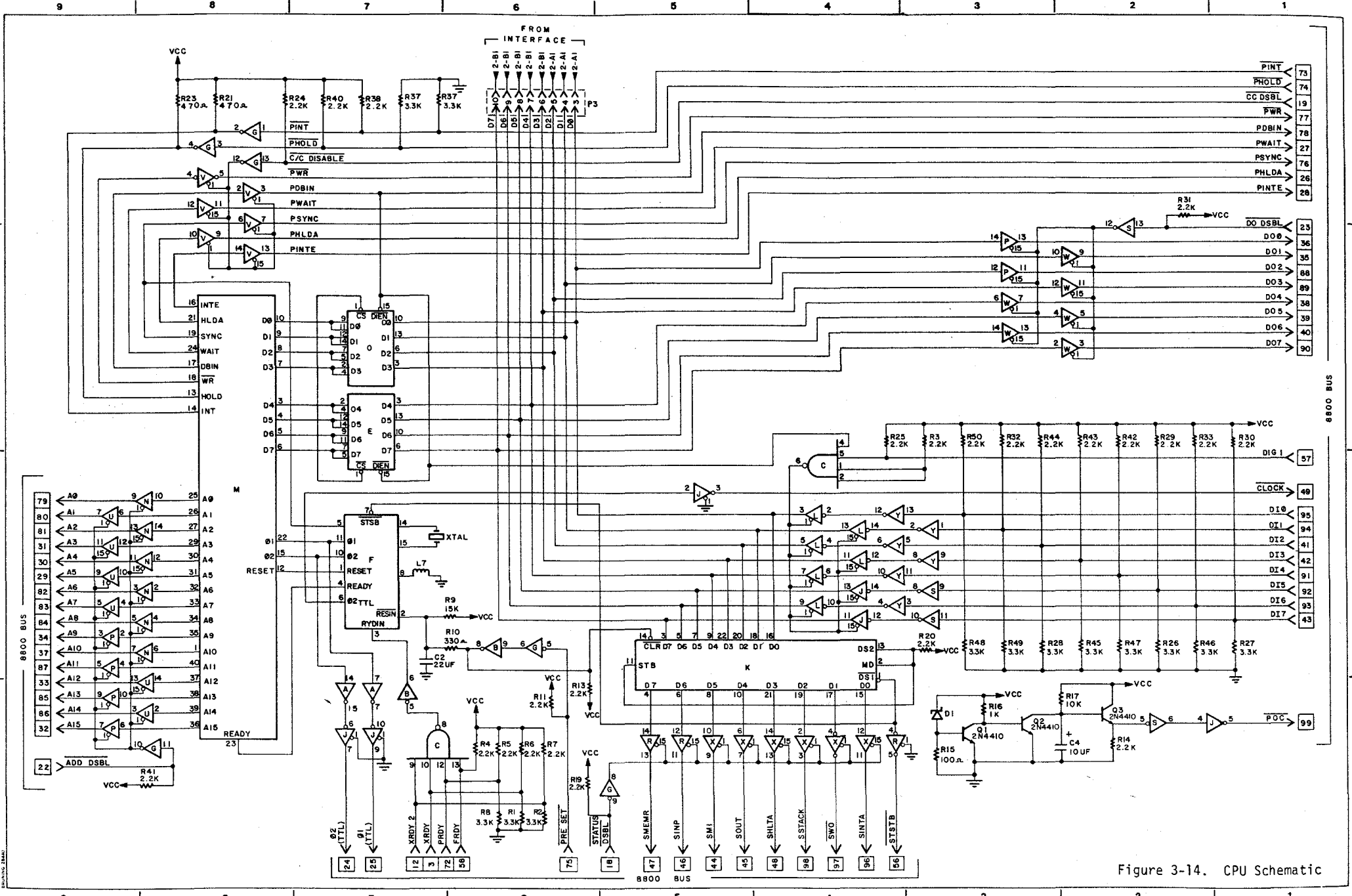
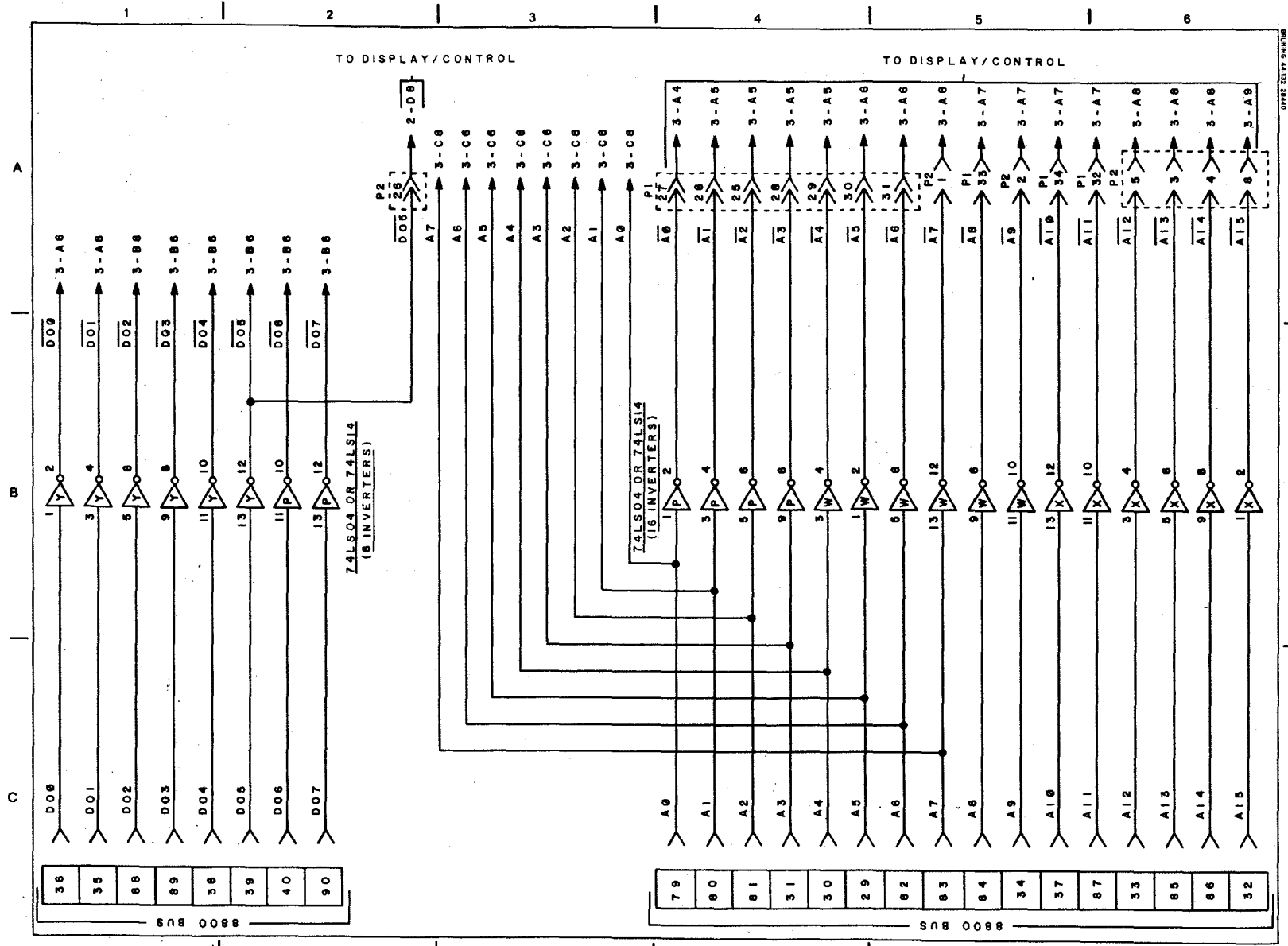

Figure 3-14. CPU Schematic





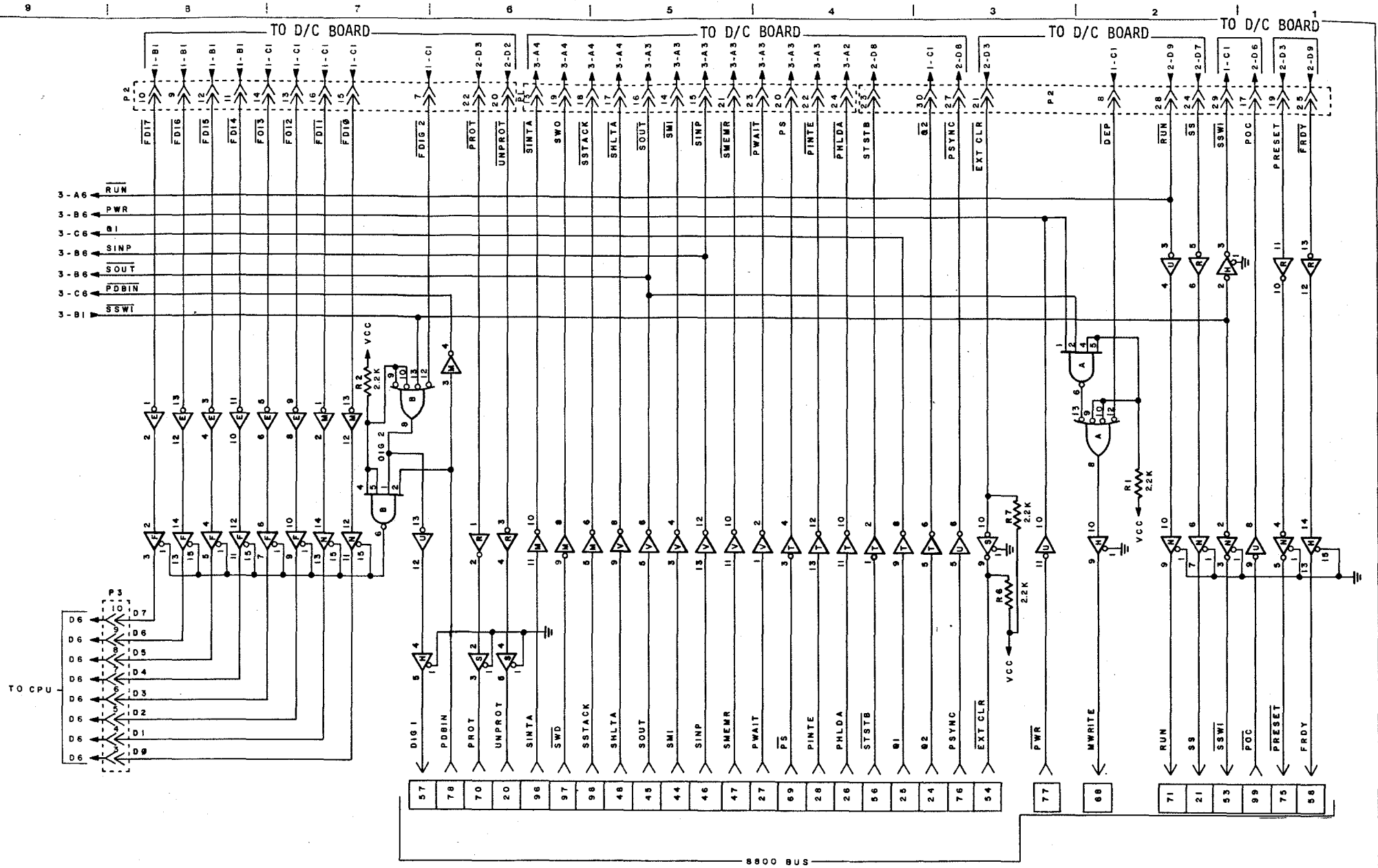

Figure 3-15. Interface Schematic (sheet 2 of 3)

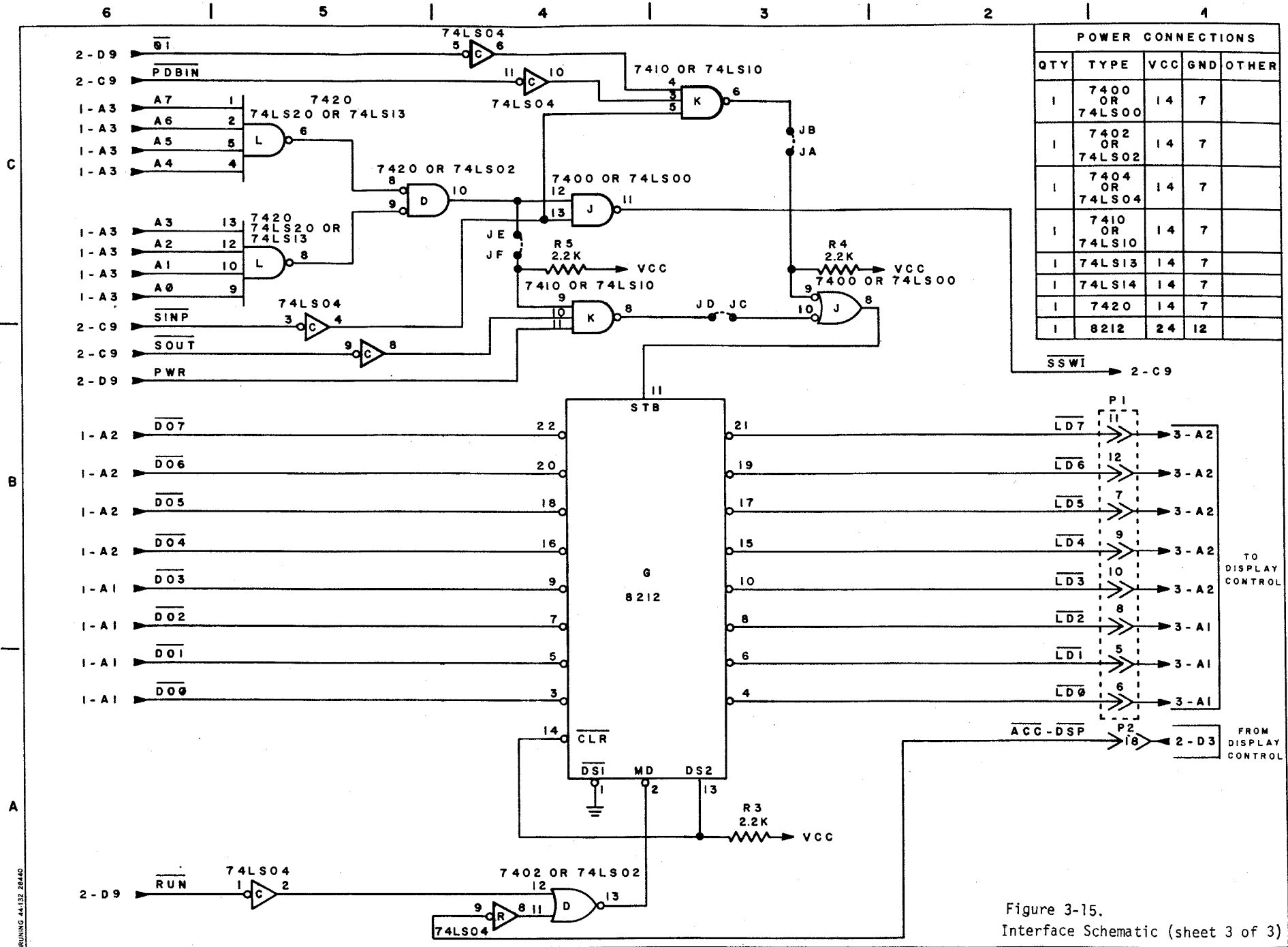
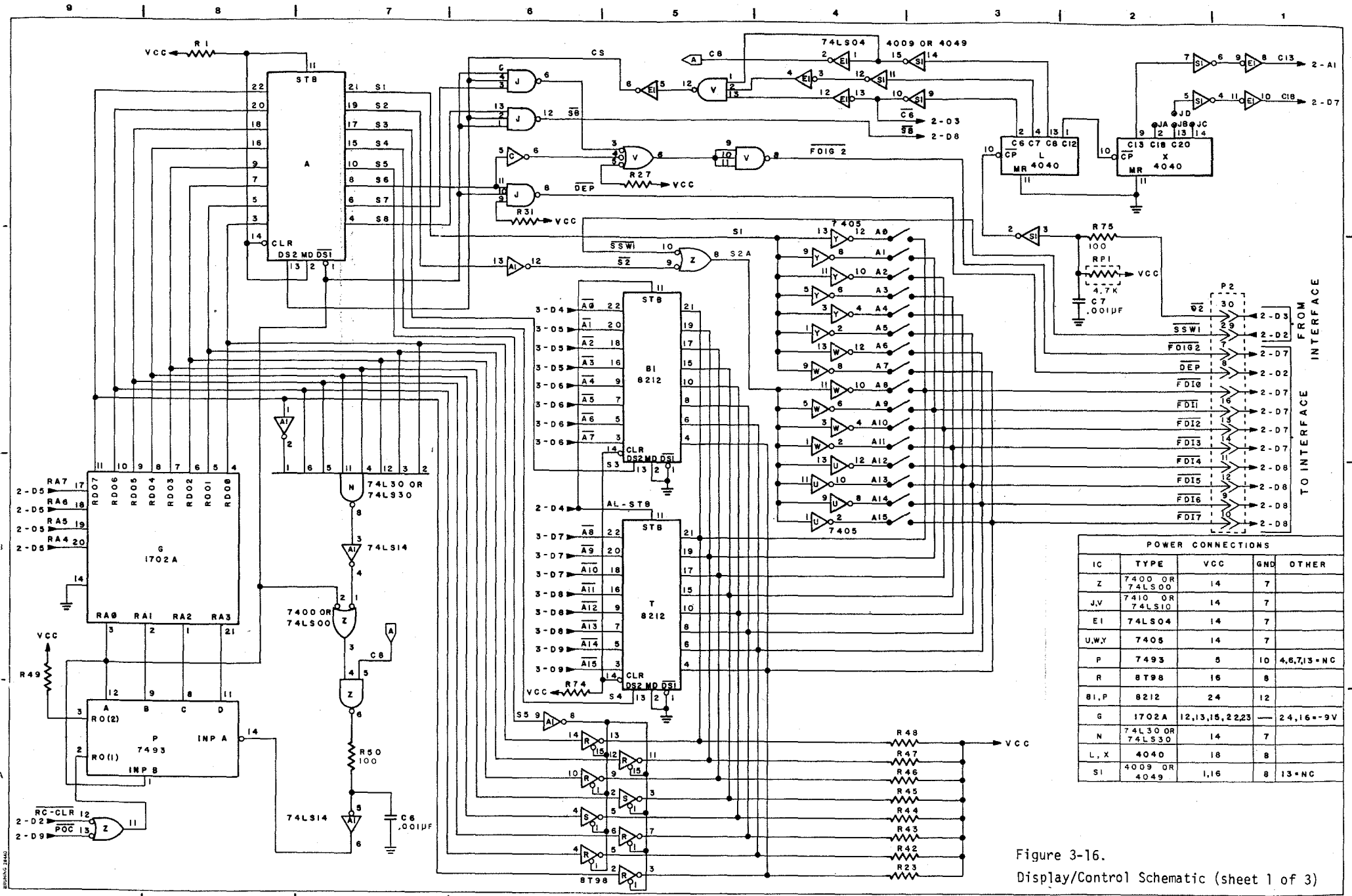

Figure 3-15.  
Interface Schematic (sheet 3 of 3)



| POWER CONNECTIONS |                  |               |     |             |
|-------------------|------------------|---------------|-----|-------------|
| IC                | TYPE             | VCC           | GND | OTHER       |
| Z                 | 7400 OR 74LS00   | 14            | 7   |             |
| J,V               | 7410 OR 74LS10   | 14            | 7   |             |
| EI                | 74LS04           | 14            | 7   |             |
| U,W,Y             | 7405             | 14            | 7   |             |
| P                 | 7493             | 5             | 10  | 4,6,7,13=NC |
| R                 | 8T98             | 16            | 8   |             |
| 81,P              | 8212             | 24            | 12  |             |
| G                 | 1702A            | 12,13,15,2,23 |     | 24,16=-9V   |
| N                 | 74LS30 OR 74LS33 | 14            | 7   |             |
| L,X               | 4040             | 18            | 8   |             |
| SI                | 4009 OR 4049     | 1,16          | 8   | 13=NC       |

Figure 3-16.  
Display/Control Schematic (sheet 1 of 3)

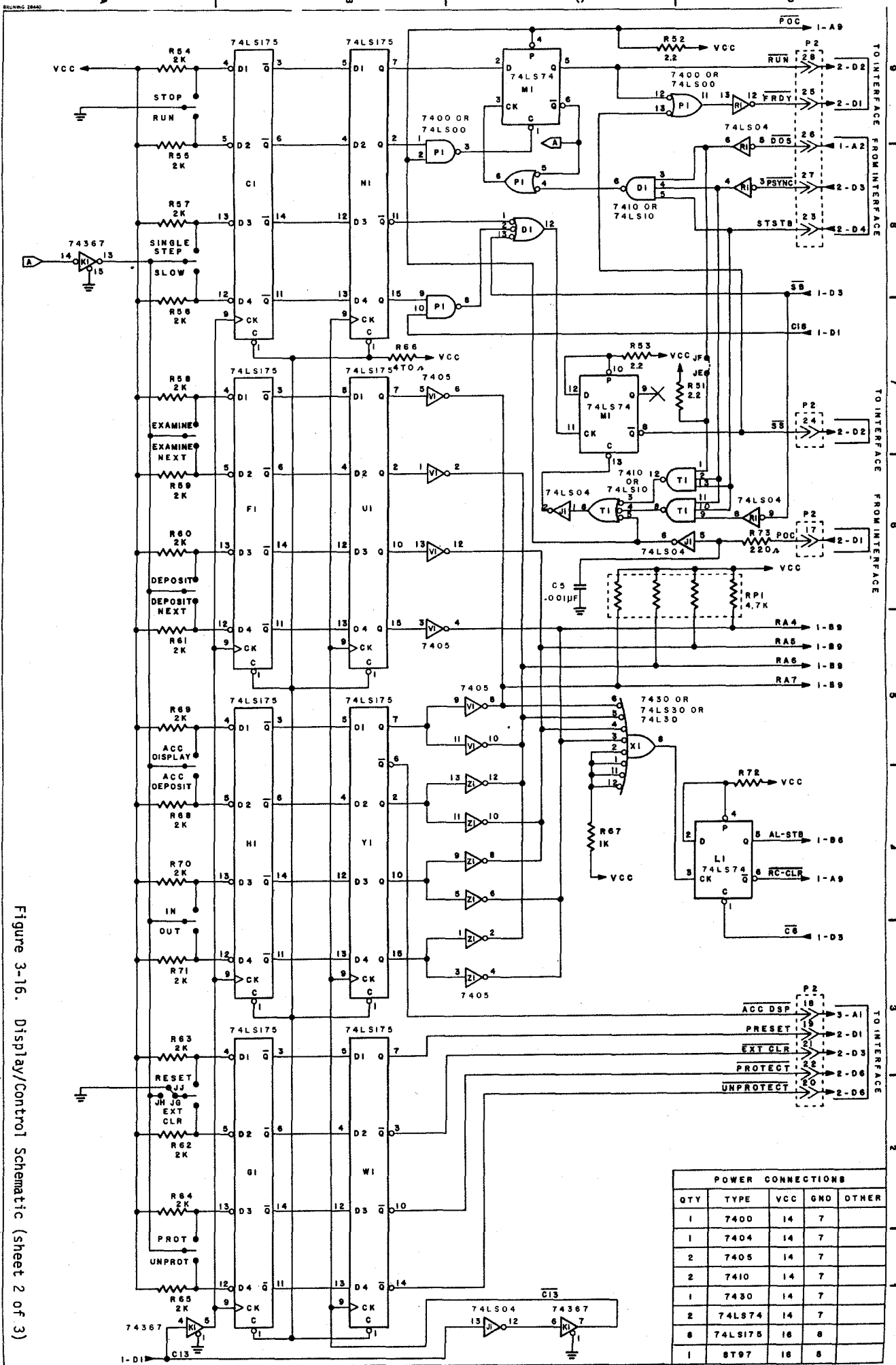
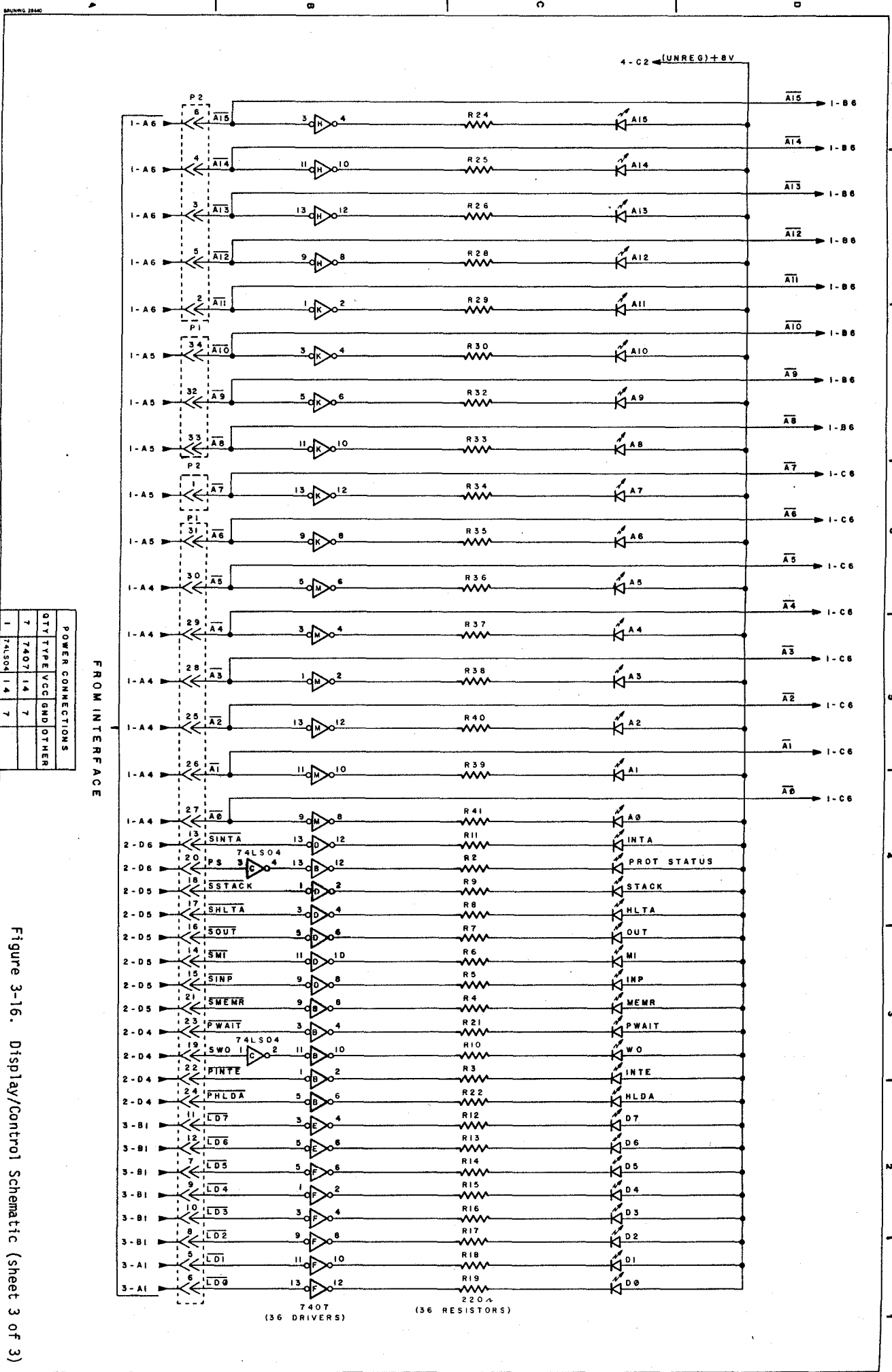

Figure 3-16. Display/Control Schematic (sheet 2 of 3)



FROM INTERFACE

| POWER CONNECTIONS |        |     |           |
|-------------------|--------|-----|-----------|
| QTY               | TYPE   | VCC | GND/OTHER |
| 7                 | 7407   | 14  | 7         |
| 1                 | 74LS04 | 14  | 7         |

Figure 3-16. Display/Control Schematic (sheet 3 of 3)

740T (36 DRIVERS)

(36 RESISTORS)

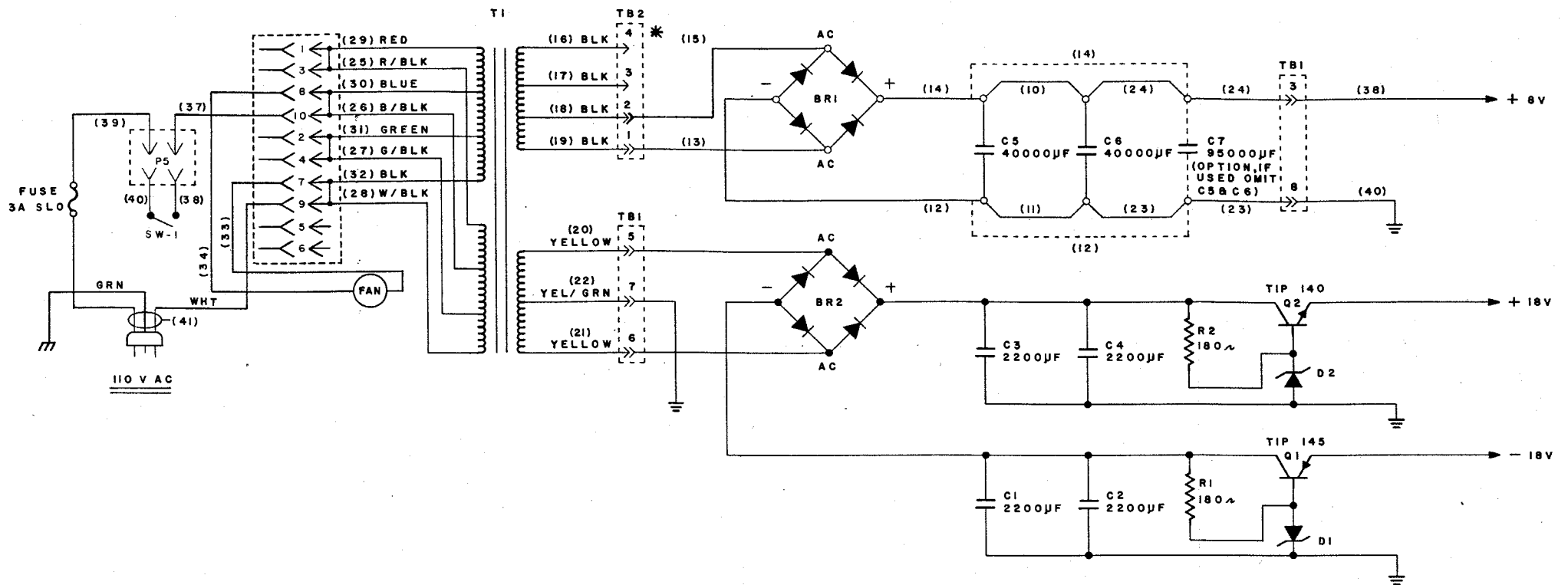

90 V  
 // GREEN & GRN./BLK. TO PIN 1  
 // BLACK & WHT./BLK. TO PIN 2

110 V  
 // BLUE & BLUE/BLK. TO PIN 1  
 // BLACK & WHT./BLK. TO PIN 2

130 V  
 // RED & RED/BLK. TO PIN 1  
 // BLACK & WHT./BLK. TO PIN 2

180 V  
 IN 1 WHT./BLK.  
 IN 2 GREEN  
 JUMP  
 BLACK & GREEN/BLK.

220 V  
 IN 1 WHT./BLK.  
 IN 2 BLUE  
 JUMP  
 BLACK & BLUE/BLK.

260 V  
 IN 1 WHT./BLK.  
 IN 2 RED  
 JUMP  
 BLACK & RED/BLACK

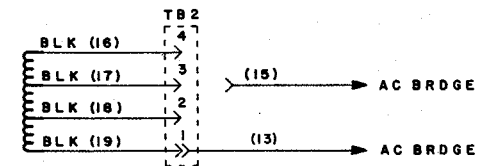

\*

| AMPS   | TB2   |
|--------|-------|
| 0 - 4  | pin 2 |
| 4 - 9  | pin 3 |
| 9 - 18 | pin 4 |

Figure 3-17. Power Supply Board Schematic  
 3-113/(3-114 blank)

April, 1977  
6800b

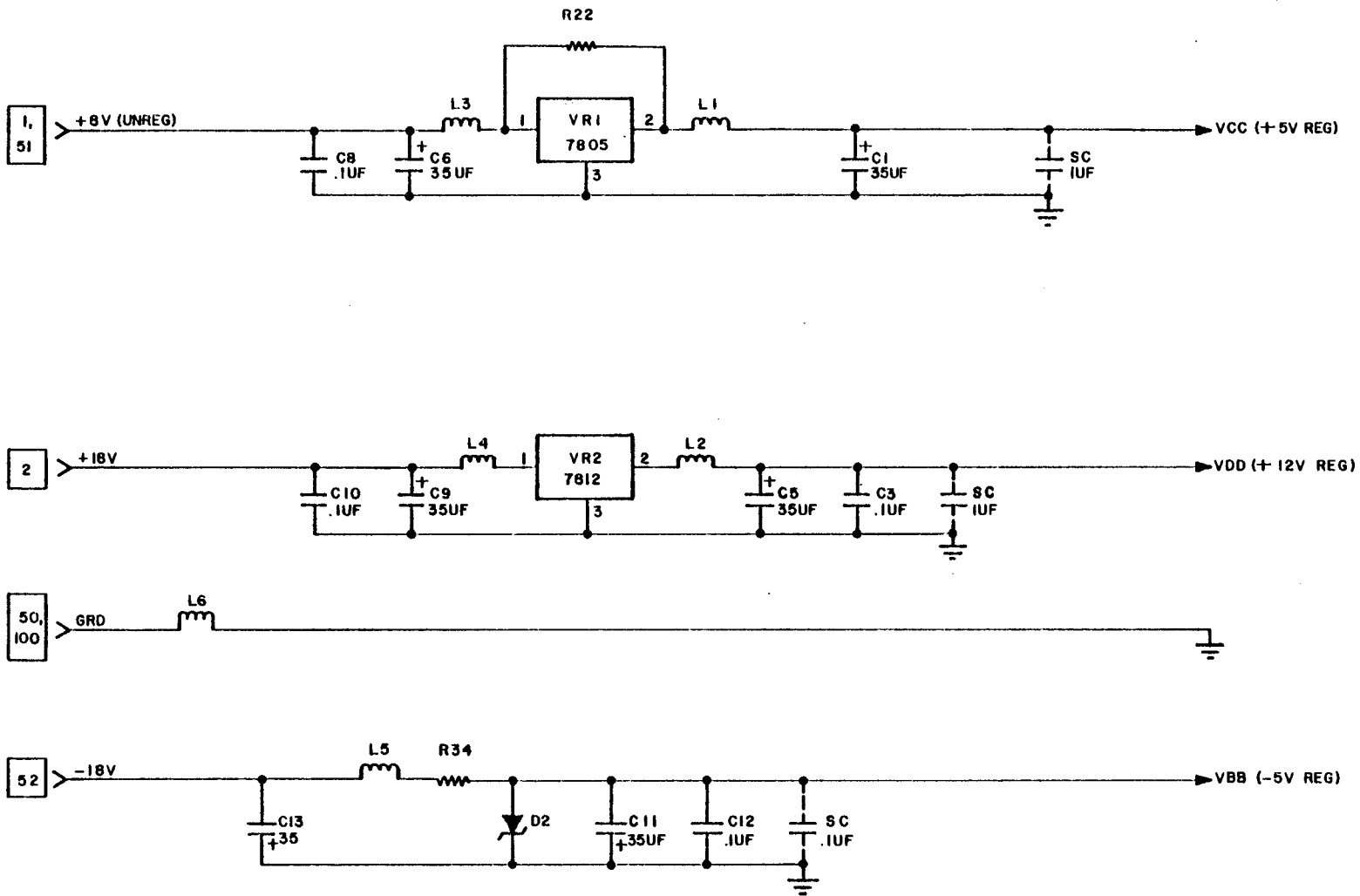

| REF DESIG | TYPE                   | VCC | GRD | OTHER | REF DESIG              | TYPE                | VCC | GRD | OTHER    |
|-----------|------------------------|-----|-----|-------|------------------------|---------------------|-----|-----|----------|
|           |                        |     |     |       | M                      | 8080A               | 20  | 2   |          |
| G, B      | 74LS04                 | 14  | 7   |       | J, X, R, V,<br>N, U, P | 74368<br>OR<br>8198 | 16  | 8   |          |
| C         | 74LS13<br>OR<br>74LS20 | 14  | 7   |       | K                      | 8212                | 24  | 12  |          |
| S, Y      | 74LS14                 | 14  | 7   |       | D, E                   | 8216                | 16  | 8   |          |
|           |                        |     |     |       | F                      | 8224                | 16  | 8   | VDD = 9  |
| P, W      | 74367                  | 16  | 8   |       | A                      | 4009                | 1   | 8   | VDD = 16 |

Figure 3-18. CPU Voltage Regulator Schematic

3-115/(3-116 blank)

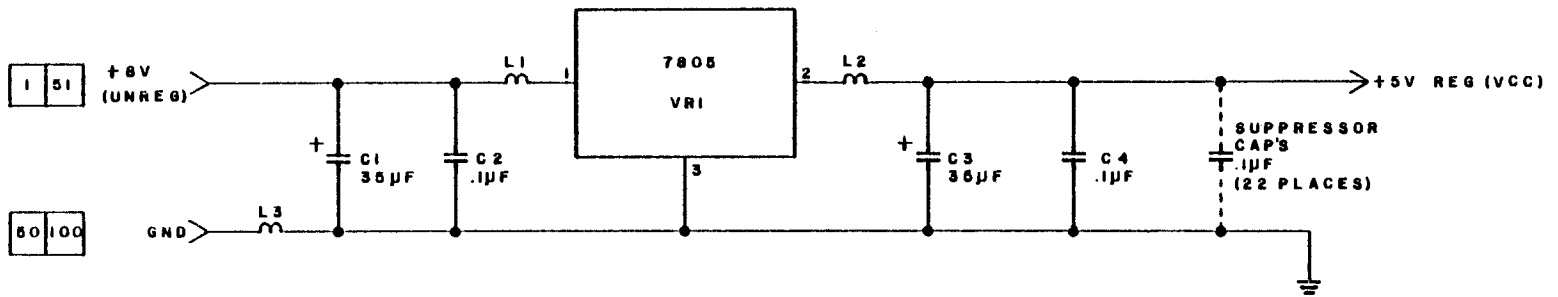

Figure 3-19. Interface Voltage Regulator Schematic



Apr 11, 1977  
8800b

3-119/(3-120 blank)

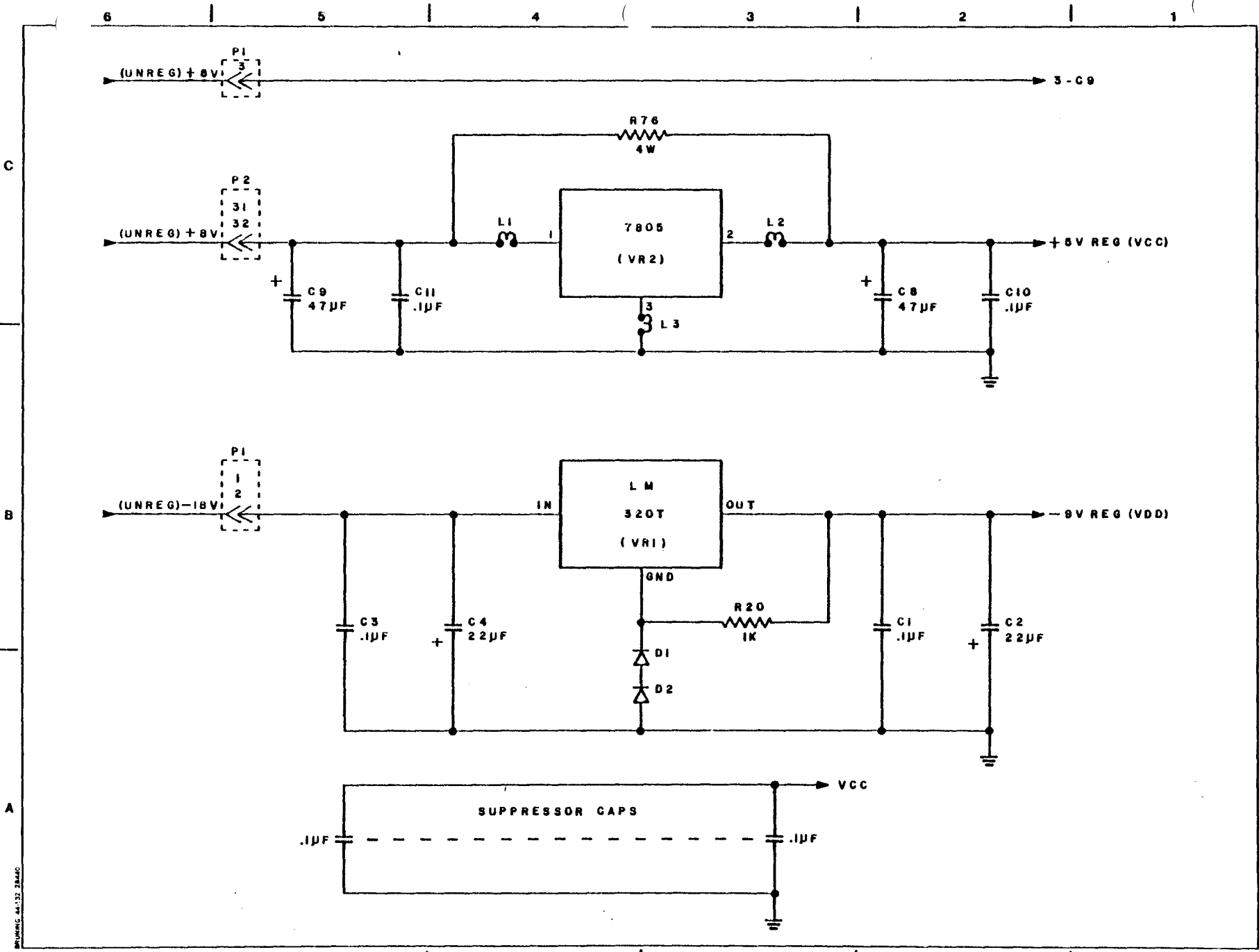

Figure 3-20. Display/Control Voltage Regulator Schematic

# altair 8800b

## SECTION IV

### TROUBLESHOOTING

## PREFACE

Section IV is designed to aid the user in pinpointing trouble areas and correcting problems that may be encountered with the Altair 8800b computer. The text that follows contains detailed instructions that should help in locating and correcting most problems. However, if the malfunction(s) cannot be rectified, send the unit to the MITS Repair Department or your local Altair dealer.

Section IV is divided into five major sections :

- 4-1) Introduction to Troubleshooting which contains general procedures that should always be followed, and IC static level charts showing the proper indications for the most common trouble areas;
- 4-2) Visual Inspection which contains procedures for locating problems caused by improper assembly;
- 4-3) Preliminary Check which contains tests for voltages and waveforms;
- 4-4) Non-PROM Related Switch Problems which concerns the RUN/STOP, SINGLE STEP/SLOW, RESET/EXTERNAL CLEAR and PROTECT/UNPROTECT switches;
- 4-5) PROM Related Switch Problems which deals with the EXAMINE/EXAMINE NEXT, DEPOSIT/DEPOSIT NEXT, ACCUMULATOR DISPLAY/ACCUMULATOR LOAD and IN/OUT switches.

Sections 4-3, 4-4 and 4-5 are presented in chart form, indicating the testing instructions, the correct indication, the incorrect indication and the procedures for remedying the problem.

Before beginning the actual troubleshooting procedures, the Theory of Operation and Section 4-1 should be reviewed. Refer to these portions of the manual when necessary.

An oscilloscope and an inexpensive multimeter will be needed to perform these troubleshooting procedures. The oscilloscope should be used to detect and measure pulses; the multimeter should be used to check voltage levels and continuity.

## 4-1. INTRODUCTION TO TROUBLESHOOTING

### A. Basic Troubleshooting Procedures

Paragraphs 1, 2, 3 and 4 contain general instructions for testing ICs, diodes, transistors and bridge rectifiers, respectively. These procedures should be followed each time the instructions (in the tables that follow) specify that one of the above mentioned components be checked.

#### 1. ICs

- a. With a voltmeter (or oscilloscope), check the IC pin for the proper voltage level or pulse. Make sure that the voltmeter is touching only one pin at a time; if the voltmeter should come in contact with more than one pin, erroneous readings and shorts may occur. (Note: Because the entire system is based upon the 8080 microprocessor chip, IC M on the CPU board, be especially careful when checking this component.) If the correct voltage is not present at the IC:
  1. Use the schematic to trace the signal back to its original source, checking for proper logic operation at each gate.
  2. Visually inspect the area surrounding the IC for solder bridges or opens.
- b. Never assume that when a signal leaves its source it will always reach its destination. Check for continuity with an ohmmeter (set at X1K ohms or higher to protect the ICs from the ohmmeter's current). If opens in the lands are found, solder over them.
- c. Check for power (Vcc) and Ground at the IC. Several of the schematics (in the Theory of Operation section) contain charts indicating the Vcc and Ground pins for each IC. If Vcc and Ground are present, test the IC according to the steps below.
  - 1) For ICs with sockets:
    - a) Turn power off and remove the IC from its socket.
    - b) Bend the suspected output pin up and reinstall the IC into its socket.
    - c) Turn power on and check for proper logic operation.

NOTE

Removing an IC pin from its socket or from the board may change the IC's input level. When checking for proper logic, refer to the truth tables (pages 3-5 through 3-8) associated with that type of gate.

- d) If the IC does not operate properly, replace it. If it does operate properly, bend the pin back and reinsert it into the socket. Look for a solder short or bridge and repair as necessary.
- 2) For ICs without sockets:
- a) Turn power off and cut the suspected IC pin where it meets the component side of the board.
  - b) Bend the pin up and turn power on.
  - c) Check for proper logic operation (as shown in the appropriate truth table).
  - d) If the IC does not operate properly, replace it. If it does operate properly, resolder the pin to the board and look for a solder short or bridge. Repair as necessary.

NOTE

If an IC without a supplied socket needs to be replaced, you may wish to install a good-quality socket with it. Because sockets don't have to be removed from the board in order to test the IC, installation of sockets will aid in future troubleshooting and will prevent wear and tear on the board.

2. Diodes

Diodes can be easily tested with an ohmmeter set at X100 ohms. Turn power off and unsolder one lead from the board. To forward bias the diode, place the ohmmeter's positive lead on the diode's anode lead and the ohmmeter's negative lead on the diode's cathode lead. (The cathode lead is on the side marked with a bar.) The ohmmeter should show a LOW reading (15-300 ohms). To reverse bias the diode, transpose the ohmmeter's leads and check for a HIGH resistance reading (above 1K ohms). If the diode's readings do not correspond with the readings shown here, the diode should be replaced.

### 3. Transistors

Transistors can be tested with an ohmmeter set at X100 ohms. The following chart shows the correct readings for transistors with at least two leads removed from the board. Refer to the chart on page 5-9 in the Assembly section of the manual for lead identification, and compare the transistor's resistance to the resistance indicated in the chart below. Q1, Q2 and Q3 on the CPU board and Q2 on the Power Supply board are NPN transistors. Q1 on the Power Supply board is a PNP transistor.

| Ohmmeter Lead Placement                             | Transistor Resistance |                 |
|---|-----------------------|-----------------|
|   | NPN Transistors       | PNP Transistors |
| Positive lead to emitter<br>Negative lead to base   | HIGH resistance       | LOW resistance  |
| Positive lead to base<br>Negative lead to emitter   | LOW resistance        | HIGH resistance |
| Positive lead to base<br>Negative lead to collector | LOW resistance        | HIGH resistance |
| Positive lead to collector<br>Negative lead to base | HIGH resistance       | LOW resistance  |
| HIGH = 2K ohms or higher<br>LOW = 1K ohms or lower  |                       |                 |

### 4. Bridge Rectifiers

Unplug the chassis, remove the AC wires to TB1 and refer to the Diode testing instructions on page 4-6 to test the bridge rectifiers.

#### B. Normal Output Voltage Levels

##### 1. TTL Gates (7400 Series ICs) and MOS ICs:

| Condition  | Voltage     |
|------------|-------------|
| Valid LOW  | .8v or less |
| Valid HIGH | 2v - 4v     |

An output in the range of .8v - 2v indicates a problem. (Note: Voltages can vary  $\pm 10\%$ .)

##### 2. Open Collector Gates

Open collector outputs, such as those of ICs Y, W, U, F, B and K on the Display/Control board, must be connected to +5v or +8v to operate properly. The outputs of ICs Y, W and U are tied to Vcc through resistors R41-R48 when the corresponding address switch is in the "up" position. When the switch is in the down

position, the output will be disconnected from Vcc and will not allow signals to go through.

3. Tri-State Buffers (when enabled)

| <u>Condition</u> | <u>Voltage</u> |
|------------------|----------------|
| Valid LOW        | .8v or lower   |
| Valid HIGH       | 2v or higher   |

An output in the range of .8v - 2v indicates a problem. (Note: as Voltages can vary +10%.)

When disabled, tri-state buffers will have various voltages at their outputs.

C. Static Levels

1. IC Levels

Table 4-1, starting on page 4-9, shows the proper static levels of the most common problem areas, assuming the computer is in a "stopped" state (M1, MEMR and WAIT).

Table 4-1. Static Levels of the Most Common Problem Areas

| <u>Board</u>    | <u>Schematic</u>   | <u>IC</u>                         | <u>Pin #</u>                   | <u>Static Level</u>              |
|-----------------|--------------------|-----------------------------------|--------------------------------|----------------------------------|
| Display/Control | 3-16, sheet 1 of 3 | G                                 | 17, 18, 19, 20                 | HIGH                             |
|                 |                    | P                                 | 2, 8, 9, 11, 14                | LOW                              |
|                 |                    | P                                 | 12                             | HIGH                             |
|                 |                    | N                                 | 8                              | LOW                              |
|                 |                    | A                                 | 4, 6, 8, 10, 15, 17,<br>19, 21 | LOW                              |
|                 |                    | R                                 | 15, 1                          | HIGH                             |
|                 |                    | S                                 | 1                              | HIGH                             |
|                 |                    | Y                                 | 1, 3, 5, 11, 9, 13             | LOW                              |
|                 |                    | W                                 | 13, 9, 11, 5, 3, 1             | LOW                              |
|                 |                    | U                                 | 1, 9, 11, 13                   | LOW                              |
|                 |                    | J                                 | 8, 12                          | HIGH                             |
|                 |                    | Z                                 | 5                              | C8 (see waveform #5, page 4-30)  |
|                 |                    | V                                 | 8                              | HIGH                             |
|                 |                    | J                                 | 4, 2                           | CS                               |
|                 |                    | E1                                | 6                              | CS                               |
|                 | A                  | 13                                | CS                             |                                  |
|                 | 3-16, sheet 2 of 3 | C1, F1, H1, G1,<br>N1, U1, Y1, W1 | 9                              | C13 (see waveform #4, page 4-29) |
|                 |                    | V1                                | 6, 2, 4, 12, 8, 10             | HIGH                             |
|                 |                    | Z1                                | 2, 4, 6, 8, 10, 12             | HIGH                             |
|                 |                    | K1                                | 13                             | LOW                              |
| M1              |                    | 11                                | LOW                            |                                  |
| M1              | 8, 13              | HIGH                              |                                |                                  |
| L1              | 3, 5               | LOW                               |                                |                                  |



Table 4-1 (continued)

| <u>Board</u> | <u>Schematic</u>   | <u>IC</u> | <u>Pin #</u>       | <u>Static Level</u>                          |
|--------------|--------------------|-----------|--------------------|--|
|              |                    | L1        | 1                  | $\overline{C6}$ (see waveform #6, page 4-30) |
|              |                    | R1        | 12                 | HIGH   |
|              |                    | M1        | 2                  | LOW  |
|              |                    | M1        | 1, 3, 5            | HIGH   |
| Interface    | 3-15, sheet 3 of 3 | G         | 2, 13, 14          | HIGH   |
|              |                    | G         | 1, 11              | LOW  |
|              |                    | K         | 6                  | HIGH   |
|              |                    | D         | 10                 | LOW  |
|              |                    | J         | 11                 | HIGH   |
|              |                    | K         | 8                  | HIGH   |
|              | 3-15, sheet 2 of 3 | B         | 6, 2, 12, 13       | HIGH   |
|              |                    | E         | 2, 4, 6, 8, 10, 12 | LOW  |
|              |                    | M         | 2, 12              | LOW  |
|              |                    | A         | 12, 13, 6, 2       | HIGH   |
|              |                    | A         | 1, 8               | LOW  |
|              |                    | N         | 6, 10              | LOW  |
| CPU          | 3-14               | N         | 4, 2               | HIGH   |
|              |                    | H         | 14                 | LOW  |
|              |                    | C         | 6, 13              | LOW  |
|              |                    | C         | 8, 4               | HIGH   |
|              |                    | M         | 23, 12             | LOW  |
|              |                    | D, E      | 15                 | HIGH   |
|              |                    | F         | 7, 2               | HIGH   |

## 2. Mother Board Static Levels

Table 4-2 shows the proper static levels of the mother board, assuming the computer is in a "stopped" state (M1, MEMR and WAIT). Note that the levels on the pins of the 8080a (IC M on the CPU board) are reflected on the mother board as well as the front panel LEDs. For example:

A HIGH level on pin 24 (WAIT) of IC M on the CPU board causes bus pin 27 to go HIGH, which in turn causes the WAIT light on the front panel to light.

HIGH pulses on pin 27 (address line A2) of IC M on the CPU board produce pulses on bus pin 81, which cause A2 on the front panel to light (dimly).

Table 4-2. Mother Board Static Levels

| <u>Bus #</u> | <u>Symbol</u>  | <u>Name</u>                    | <u>Static Level</u>              |
|--------------|----------------|--------------------------------|----------------------------------|
| 1            | +8v            | +8 volts                       |                                  |
| 2            | +18v           | +18 volts                      |                                  |
| 3            | XRDY           | EXTERNAL READY                 | HIGH                             |
| 4            | VI0            | VECTORED INTERRUPT LINE #0     | LOW                              |
| 5            | VI1            | VECTORED INTERRUPT LINE #1     | LOW                              |
| 6            | VI2            | VECTORED INTERRUPT LINE #2     | LOW                              |
| 7            | VI3            | VECTORED INTERRUPT LINE #3     | LOW                              |
| 8            | VI4            | VECTORED INTERRUPT LINE #4     | LOW                              |
| 9            | VI5            | VECTORED INTERRUPT LINE #5     | LOW                              |
| 10           | VI6            | VECTORED INTERRUPT LINE #6     | LOW                              |
| 11           | VI7            | VECTORED INTERRUPT LINE #7     | LOW                              |
| 12*          | XRDY2          | Extra READY Line               | HIGH                             |
| 13-17        | Not Used       |                                |                                  |
| 18           | <u>STA DSB</u> | <u>STATUS DISABLE</u>          | HIGH                             |
| 19           | <u>C/C DSB</u> | <u>COMMAND/CONTROL DISABLE</u> | HIGH                             |
| 20**         | UNPROT         | UNPROTECT                      | LOW                              |
| 21**         | SS             | SINGLE STEP                    | LOW                              |
| 22           | <u>ADD DSB</u> | <u>ADDRESS DISABLE</u>         | HIGH                             |
| 23           | <u>DO DSB</u>  | <u>DATA OUT DISABLE</u>        | HIGH                             |
| 24           | Ø2             | PHASE 2 CLOCK                  | See waveforms 2 and 3, page 4-26 |
| 25           | Ø1             | PHASE 1 CLOCK                  | See waveforms 2 and 3, page 4-26 |

| <u>Bus #</u> | <u>Symbol</u>  | <u>Name</u>                  | <u>Static Level</u>                 |
|--------------|----------------|------------------------------|-------------------------------------|
| 26           | PHLDA          | HOLD ACKNOWLEDGE             | LOW                                 |
| 27           | PWAIT          | WAIT                         | HIGH                                |
| 28           | PINTE          | INTERRUPT ENABLE             | LOW                                 |
| 29           | A5             | ADDRESS LINE #5              |                                     |
| 30           | A4             | ADDRESS LINE #4              |                                     |
| 31           | A3             | ADDRESS LINE #3              |                                     |
| 32           | A15            | ADDRESS LINE #15             |                                     |
| 33           | A12            | ADDRESS LINE #12             |                                     |
| 34           | A9             | ADDRESS LINE #9              |                                     |
| 35           | D01            | DATA OUT LINE #1             |                                     |
| 36           | D00            | DATA OUT LINE #0             |                                     |
| 37           | A10            | ADDRESS LINE #10             |                                     |
| 38           | D04            | DATA OUT LINE #4             |                                     |
| 39           | D05            | DATA OUT LINE #5             |                                     |
| 40           | D06            | DATA OUT LINE #6             |                                     |
| 41           | DI2            | DATA IN LINE #2              |                                     |
| 42           | DI3            | DATA IN LINE #3              |                                     |
| 43           | DI7            | DATA IN LINE #7              |                                     |
| 44           | SM1            | M1 (Instruction Fetch Cycle) | HIGH                                |
| 45           | SOUT           | OUT (Output Write)           | LOW                                 |
| 46           | SINP           | INP (Input Read)             | LOW                                 |
| 47           | SMEMR          | MEMR (Memory Read)           | HIGH                                |
| 48           | SHLTA          | HLTA (Halt Acknowledge)      | LOW                                 |
| 49           | <u>CLOCK</u>   | <u>CLOCK</u>                 | See Waveforms 2<br>and 3, page 4-28 |
| 50           | GND            | GROUND                       |                                     |
| 51           | +8v            | +8 volts                     |                                     |
| 52           | -18v           | -18 volts                    |                                     |
| 53**         | <u>SSW DSB</u> | <u>SENSE SWITCH DISABLE</u>  | HIGH                                |
| 54           | <u>EXT CLR</u> | <u>EXTERNAL CLEAR</u>        | HIGH                                |
| 55           | RTC            | REAL TIME CLOCK              |                                     |
| 56*          | <u>STSTB</u>   | <u>STATUS STROBE</u>         | HIGH                                |
| 57**         | DIG1           | DIGITAL #1                   | HIGH                                |
| 58**         | FRDY           | Front Panel READY            | LOW                                 |
| 59-67        | Not Used       |                              |                                     |
| 68           | MWRT           | MEMORY WRITE                 | LOW                                 |
| 69           | <u>PS</u>      | <u>PROTECT STATUS</u>        | HIGH                                |

| <u>Bus #</u> | <u>Symbol</u>              | <u>Name</u>                              | <u>Static Level</u> |
|--------------|----------------------------|--|---------------------|
| 70**         | PROT                       | PROTECT                                  | LOW                 |
| 71**         | RUN                        | RUN                                      | LOW                 |
| 72           | PRDY                       | READY                                    | HIGH                |
| 73           | $\overline{\text{PINT}}$   | $\overline{\text{INTERRUPT REQUEST}}$    | HIGH                |
| 74           | $\overline{\text{PHOLD}}$  | $\overline{\text{HOLD}}$                 | HIGH                |
| 75           | $\overline{\text{PRESET}}$ | $\overline{\text{RESET}}$                | HIGH                |
| 76           | PSYNC                      | SYNC                                     | LOW                 |
| 77           | $\overline{\text{PWR}}$    | $\overline{\text{WRITE}}$                | HIGH                |
| 78           | PDBIN                      | DATA BUS IN                              | HIGH                |
| 79           | A0                         | ADDRESS LINE #0                          |                     |
| 80           | A1                         | ADDRESS LINE #1                          |                     |
| 81           | A2                         | ADDRESS LINE #2                          |                     |
| 82           | A6                         | ADDRESS LINE #6                          |                     |
| 83           | A7                         | ADDRESS LINE #7                          |                     |
| 84           | A8                         | ADDRESS LINE #8                          |                     |
| 85           | A13                        | ADDRESS LINE #13                         |                     |
| 86           | A14                        | ADDRESS LINE #14                         |                     |
| 87           | A11                        | ADDRESS LINE #11                         |                     |
| 88           | D02                        | DATA OUT LINE #2                         |                     |
| 89           | D03                        | DATA OUT LINE #3                         |                     |
| 90           | D07                        | DATA OUT LINE #7                         |                     |
| 91           | DI4                        | DATA IN LINE #4                          |                     |
| 92           | DI5                        | DATA IN LINE #5                          |                     |
| 93           | DI6                        | DATA IN LINE #6                          |                     |
| 94           | DI1                        | DATA IN LINE #1                          |                     |
| 95           | DIO                        | DATA IN LINE #0                          |                     |
| 96           | SINTA                      | INTA (Interrupt Request Acknowledge)     | LOW                 |
| 97           | $\overline{\text{SWO}}$    | $\overline{\text{WO}}$ (Write Operation) | HIGH                |
| 98           | SSTACK                     | STACK                                    | LOW                 |
| 99           | $\overline{\text{POC}}$    | POWER ON CLEAR                           | HIGH                |
| 100          | GND                        | GROUND                                   |                     |

\* = Not used in 8800a system.

\*\* = Not used in 8800b Turnkey system.

Note: If a static level is not indicated, the signal can be either HIGH or LOW.

## 4-2. VISUAL INSPECTION

### A. Component Inspection

The first step in troubleshooting is to carefully examine each board for solder bridges, open lands, misplaced components, etc. A thorough inspection of this kind will eliminate one possibility for errors and will allow troubleshooting efforts to be concentrated elsewhere. Carefully check each board using the list below:

1. Look for solder bridges.
2. Look for leads that have not been soldered.
3. Look for cold solder connections (cold solder connections do not have a "shiny" appearance).
4. Examine the board's lands for "hairline opens" or bridges."
5. Check the ICs for proper pin placement and good socket connections.
6. Examine the electrolytic and tantalum capacitors for proper polarity.
7. Examine the diodes for proper polarity.
8. Examine the LEDs for proper polarity.
9. Check the color codes on all resistors.

### B. Wiring Inspection

**CAUTION**

The computer should be unplugged for this check.

1. Referring to Figure 5-50 on page 5-58 in the Assembly section of the manual, check for incorrect wiring on the mother board.
2. With an ohmmeter, check the power supply wiring on the terminal block (TB1). Check for resistance (about 100 ohms) between pins 2 and 7, 10 and 7, 1 and 7, 2 and 10, 2 and 1 and 1 and 10. If a reading of less than 10 ohms appears, recheck the wiring. Also check continuity from mother board bus pins 1, 2, 52 and 50 to corresponding terminal block pins 2, 10, 1 and 7. If a reading of more than 100 ohms appears, inspect the wiring from the mother board to TB1.

#### 4-3. PRELIMINARY CHECK

The procedures outlined in Section 4-3 are general tests that should be made before going on to the specific problems presented in Sections 4-4 and 4-5. Follow the instructions in the order in which they are given, and always complete each step before going on to the next.

1. Before installing the boards and applying power to the computer, use an ohmmeter to check the resistance of the edge connectors on the mother board. Test the consecutively numbered pins down each row (1, 2, 3 . . . etc.), then cross check the pins (1-51, 2-52 . . . etc.). A LOW resistance reading should appear at pins 1, 50, 51 and 100. If a LOW reading appears at any other location, examine the back of the board for solder bridges or etching errors.
2. Turn the computer on and check for the following voltages on the Power Supply board's terminal block (TB1). See page 5-58 in the Assembly section of the manual for pin locations.

| <u>Pin #</u> | <u>Voltage</u>               |
|--------------|------------------------------|
| 2, 3, 4      | +8v to +10v (unregulated)    |
| 10           | +16v to +18v (pre-regulated) |
| 1            | -16v to -18v (pre-regulated) |
| 7, 8         | Ground                       |

#### WARNING

When testing components on the Power Supply board, be extremely careful not to touch the AC wiring. Always unplug the chassis when testing continuity or replacing components.

- a. If the +8 voltage is absent from pins 2, 3 or 4 of TB1, check for AC at pins 1 and 2 of TB2. If absent, unplug the chassis and check continuity and wiring at connector P4. Also check the fuse and the wiring to the AC cord. Plug in the chassis. If AC is present at pins 1 and 2 of TB2, check the wiring from TB2 to BR1 and from BR1 to TB1. If AC is present at BR1, but no output voltage appears across the "+" and "-" pins of BR1, BR1 is probably defective and should be replaced.

- b. If the correct voltage does not appear at pin 10 or pin 1 of TB1, check the voltage at the base of transistor Q2 (for pin 10) and Q1 (for pin 1). If the reading is 27 volts, the transistor or diode may have shorted out. Test these components according to the instructions on pages 4-6 and 4-7.

Check for AC at TB1 pins 6 and 5. If absent, unplug the chassis and check the wiring from connector P4 to the AC cord. If AC is present at TB1, check for AC at BR2. If AC is absent at BR2, check the wiring to BR2. If AC is present at BR2, remove the "+" pin from the board and check for voltage across the "+" and "-" pins. If voltage is not present, replace BR2.

- c. If Ground does not appear at pins 7 and 8 of TB1, check the wiring from TB1 to the cross member and from the AC cable to the cross member.

3. If the fuse on the back panel blows:

- a. Check for solder bridges on the Power Supply board or the mother board.
- b. Check for proper orientation of BR2 on the Power Supply board and BR1 on the back panel.
- c. Check wiring on:
  - 1) voltage wires on the mother board
  - 2) front panel switch
  - 3) AC power cord
  - 4) Ground to +8v line
- d. Check for pinched wires and incorrectly installed components.

4. Turn power off, and install the CPU and Interface boards.

WARNING

Always turn power off when removing or installing plug-in boards or when connecting or disconnecting the Display/Control board. Failure to turn power off may cause damage to the board and the computer. Note that capacitor C7 (on the cross member) will retain a +8v charge for a few minutes after power has been turned off.

Connect the Interface board cables (P1 and P2) to the front panel and connect P3 from the CPU board to the Interface board. Turn power on. The computer should be automatically reset and in a stopped state.

If there are no memory boards in the computer at address 0, the front panel LEDs should appear as follows:

| <u>LED</u>     | <u>Condition</u> |
|----------------|------------------|
| A0-A15         | OFF              |
| M1, MEMR, WAIT | ON               |
| D0-D7          | ON               |

If a memory board is present at address 0, the D0-D7 LEDs will show the random pattern for that board.



Table 4-3. Voltage and Waveform Check

Note: The following checks should be made with the CPU, Interface and Display/Control boards installed and with power turned on (unless otherwise specified) Voltages may vary  $\pm 10\%$ .

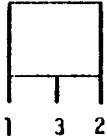
| <u>Step</u> | <u>Instructions</u>  | <u>If Correct</u>  | <u>If Incorrect</u>   |
|-------------|--|--|---|
| 1           | Check the 7805 voltage regulators on the CPU and Interface boards. | Both regulators should read +5v at pin 2. The figure below shows the correct pin locations for all voltage regulators. | If voltage is incorrect, refer to schematics 3-18 and 3-19. Check pin 3 for Ground. If absent, trace continuity back to bus pin 100 or 50. Pin 1 is the unregulated output--at least 8v. If absent, trace continuity back to bus pins 1 and 51. If Ground and sufficient unregulated voltage are present at these pins, check pin 2 of the voltage regulator for +5v. If voltage is absent, turn power off and remove voltage regulator pin 2 from the board. Turn power on and recheck for +5v. If the voltage is still below +5v, the voltage regulator is defective and should be replaced. If voltage is correct, look for a short on the board. With power off, resolder pin 2 to the board. |
|             |  |                                      |   |
| 2           | Check the 7812 voltage regulator on the CPU board.                 | It should read +12v at pin 2. Proceed to Step 3.   | If voltage is incorrect, refer to schematic 3-18 and check pin 3 for Ground. If absent, trace continuity to bus pin 100 or 50. Pin 1 is the unregulated output--at least 16v. If voltage is absent, trace continuity back to bus pin 2. If Ground and sufficient unregulated voltage are present, check pin 2 of the voltage regulator for a +12v signal. If absent, turn power off and disconnect voltage regulator pin 2 from the board.  |

| <u>Step</u> | <u>Instructions</u>                                | <u>If Correct</u>                      | <u>If Incorrect</u>   |
|-------------|--|--|---|
| 3           | Check the anode lead of diode D2 on the CPU board. | It should read -5v. Proceed to Step 4. | Turn power on and check again for the +12v signal. If the voltage is below 11v, the voltage regulator should be replaced. If the voltage is correct, look for a short on the board. Resolder pin 2 to the board.<br>If the voltage is incorrect, check D2 for proper polarity. Check for -18v on capacitor C13 (negative side) on the CPU board. If absent, trace continuity to bus pin 52.<br>Turn power off and check diode D2 according to the instructions on page 4-6. Replace, if necessary. With an ohmmeter set at X10K or higher, check the resistance from the negative side of C11 to Ground. A reading of zero ohms indicates a short on the board. Resolder the anode lead of D2 to the board. |
| 4           | Check pin 2 of VR2 on the Display/Control board.   | It should read -9v. Proceed to Step 5. | If the voltage is incorrect, check for -18v on pin 3 of the voltage regulator. If absent, trace continually back to bus pin 2. Check for the correct part number on VR2, D1, D2 and R20. Turn power off and remove the anode lead of diodes D1 and D2 from the board. Check both diodes according to the instructions on page 4-6. If the readings are incorrect, replace D1 and/or D2. Remove pin 2 of VR2 from the board. Turn power on and check for a -9v reading at VR2. If incorrect, replace VR2. If correct, look for a short on the board. Resolder the output pin to the board.   |

| <u>Step</u> | <u>Instructions</u>   | <u>If Correct</u>   | <u>If Incorrect</u>   |
|-------------|---|---|---|
| 5           | On the CPU board, check the voltage on IC M pins 20, 11 and 28. Be careful not to touch more than one pin at a time.  | Pin 20 should read +5v. Pin 11 should read -5v. Pin 28 should read +12v. Proceed to Step 6. | If incorrect, use an ohmmeter set at X10K or higher to trace continuity back to the CPU board's voltage regulators. If opens are found, solder over them.   |
| 6           | On bus pins 24 and 25, check for proper $\phi 2$ and $\phi 1$ waveforms (see waveforms 2 and 3, page 4-28). On the CPU board, check for $\phi 2$ and $\phi 1$ on corresponding pins, 22 and 15 of IC M. (See waveform #1, page 4-27.) | If present, proceed to Step 7.  | If $\phi 2$ and $\phi 1$ waveforms are absent on the bus pins, trace logic through ICs J and A on the CPU board. If $\phi 2$ or $\phi 1$ is present at the inputs of IC J or IC A, but absent at the outputs, check the IC according to the instructions on page 4-5. If there is no $\phi 1$ or $\phi 2$ signal at IC A (pin 14 or 7), trace continuity to pins 10 and 11 of IC F. (Note: $\phi 1$ and $\phi 2$ are 12v in amplitude at pins 10 and 11.) If signals are absent at pins 10 and 11, check for +12v at pin 9 of IC F. If absent, trace continuity to VR2 pin 2 on the CPU board. Check for an 18 MHz signal at pins 14 and 15 of IC F. If absent, check IC F according to the instructions on page 4-5, and replace if necessary. |
| 7           | On bus pin 99, check for a HIGH POC level. This signal is usually a 4 VDC level with a small amount of AC ripple voltage.   | If present, proceed to Step 8.  | Visually inspect transistors Q1, Q2 and Q3 and diode D1 on the CPU board for proper installment. Check the base of Q1 for a 1v level. If absent, check D1 according to the instructions on page 4-6. Replace if necessary. Q1 should be active, causing a 0v level to appear at the base of Q2. If this 0v level is absent, check Q1 according to the instructions on page 4-6. Q2 should cause a 5v signal to appear at  |

| <u>Step</u> | <u>Instructions</u>  | <u>If Correct</u>               | <u>If Incorrect</u>  |
|-------------|--|---------------------------------|--|
| 8           | Pin 13 (HOLD) of IC M on the CPU board should be LOW.  | Proceed to Step 9.              | the base of Q3. If the 5v signal is absent, check Q2 according to the instructions on page 4-6. Then turn power off, and wait a moment for C4 to discharge. Remove one of the leads of C4 from the board, and measure C4's resistance with an ohmmeter. (Note: The ohmmeter needle may fluctuate slightly.) If the reading is lower than 10 ohms, replace C4. If C4 is working properly, reinstall C4 and check continuity from the base of Q3 to Vcc. Repair as necessary. The Q3 emitter should be above 2v. If not, check Q3 according to the instructions on page 4-7. Trace this HIGH level through ICs S and J on the CPU board to bus pin 99. If ICs S and J do not invert the signal, test the ICs according to the instructions on page 4-5. If a LOW is not present at IC M pin 13, check IC G on the CPU board according to the instructions on page 4-5. Check for Vcc at resistors R23 and R40. If absent, check continuity and repair as necessary. Bus pin 74 should be HIGH. If not, look for a short on the mother board. |
| 9           | On the Display/Control board check for $\emptyset 2$ at pin 10 of IC L. If $\emptyset 2$ is absent, the entire front panel will not operate. | If present, proceed to Step 10. | If $\emptyset 2$ is absent at IC L pin 10, trace continuity and logic from IC S1 on the Display/Control board through IC T on the Interface board to bus pin 24. Any inverter having a $\emptyset 2$ input, but no $\emptyset 2$ output,   |

| <u>Step</u> | <u>Instructions</u>   | <u>If Correct</u>               | <u>If Incorrect</u>  |
|-------------|---|---------------------------------|--|
|             | (Note: If you received your 8800b computer before January, 1977, an extra capacitor, <u>CZ</u> , for the Display/Control board was included in the installation instructions. <u>This capacitor is not needed and should be removed.</u> )                                |                                 | should be checked according to the instructions on page 4-5. If the IC(s) are functioning properly, look for a short and repair as necessary.  |
| 10          | On the Display/Control board, check for a $\overline{C13}$ signal (see waveform #4, page 4-29) at pin 9 of ICs C1, N1, F1, U1, H1, Y1, G1 and W1. (Note: If no switches are pressed, R54-R65 should produce a signal of approximately 4v at the input pins of these ICs.) | If present, proceed to Step 11. | If absent, trace the $\overline{C13}$ signal through ICs K1, J1, E1 and S1 to IC X pin 9 on the Display/Control board. If any of these ICs have a C13 input, but no C13 output, they should be checked according to the instructions on page 4-5. If IC X pin 9 has no C13 signal, check for a square wave (approximately .1 ms. wide) at pin 10 of IC X. If present, check IC X according to the instructions on page 4-5. If a square wave is not present at pin 10 of IC X, check IC L. If a square wave is not present at pin 1 of IC L when it is removed from the board, replace IC L. |
| 11          | Check for a HIGH $\overline{P0C}$ level at ICs M1 pin 4, P1 pin 2, T1 pin 5 and Z pin 13 on the Display/Control board.  | If present, proceed to Step 12. | If a LOW appears at any of the pins, trace $\overline{P0C}$ from the suspected pin to pin 6 of IC J1 on the Display/Control board. If $\overline{P0C}$ is absent at pin 6, check IC J1 according to the instructions on page 4-5.<br>Check the Vcc connection at R42. If Vcc is absent, check continuity to VRI pin 2 on the Display/Control board. Check the logic operation of the   |

| <u>Step</u> | <u>Instructions</u>  | <u>If Correct</u>                                       | <u>If Incorrect</u>   |
|-------------|--|---|---|
| 12          | On the Display/Control board, check for a LOW at pin 13 of IC K1. (Note: If the computer is running, pin 13 will be HIGH and only the RUN/STOP or RESET/EXT CLR switches will work.) | If present, proceed to Step 13.                         | ICs from J1 through U on the Interface board to bus pin 99. Check and replace the ICs if necessary.<br>If the computer is not in a run state and a LOW is not present at pin 13, trace logic from IC K1 to a LOW at IC M1 pin 6. Check any suspected ICs according to the instructions on page 4-5. If lifting the STOP switch does not stop the computer, continue with the remaining steps in this chart and onto Section 4-4.  |
| 13          | On the Display/Control board, check for a CS signal (see waveform #5, page 4-30) at pin 13 of IC A.  | If the proper CS signal is present, proceed to Step 14. | If the CS signal does not match waveform #5, examine IC V pins 1, 2 and 13 on the Display/Control board. Pin 1 should be a 64 $\mu$ sec. pulse width square wave; pin 2 a 32 $\mu$ sec. pulse width square wave; and pin 13 a 16 $\mu$ sec. pulse width square wave. If all of these signals are present, check ICs V and E1 according to the instructions on page 4-5.<br>If any of the signals are absent from pins 1, 2 and 13 of IC V, trace the signal back through ICs E1 and S1 to IC L. Any ICs that have input signals but no output signals should be checked according to the instructions on page 4-5. If all of the ICs are operating properly, check for the corresponding square waves at pins 2, 4 and 13 of IC L. If absent, check IC L according to the instructions on page 4-5. |

| <u>Step</u> | <u>Instructions</u>  | <u>If Correct</u>  | <u>If Incorrect</u>   |
|-------------|--|--|---|
| 14          | On the Display/Control board, check pin 1 of IC L1 for a $\overline{C6}$ signal (see waveform #6, page 4-30).  | If present, proceed to Step 15.  | If absent or incorrect, check the logic operation from IC S1 to pin 2 of IC L. Check for a 16 $\mu$ sec. square wave pulse at pin 2 of IC L. If absent, check the IC according to the instructions on page 4-5.   |
| 15          | On the Display/Control board, check pin 5 of IC Z for a C8 signal (see waveform #5, page 4-30).  | If present, proceed to Step 16.  | If absent, trace logic through ICs E1 and S1 to pin 13 of IC L on the Display/Control board. If E1 or S1 has an input signal but no output signal, check that IC according to the instructions on page 4-5. If an output is not present at IC L pin 13, check IC L.   |
| 16          | On the Display/Control board, examine the PROM, IC G. It should be labelled B D/C. If it is <u>not</u> labelled B D/C, contact the MITS Marketing Dept. or your local Altair dealer. Check for Ground at pin 14; for +5v at pins 12, 13, 15, 22 and 23; and for -9v at pins 24 and 16 (of IC G). | If IC G is labelled B D/C and if the voltage levels are correct, proceed to Step 17.   | If the +5v signal is absent, use an ohmmeter set at X1K or higher to trace continuity to VR1 pin 2. (Note: If another computer with a PROM board is available, the data in the suspected PROM can be checked by installing it in the other computer's PROM board and examining its output with Table 3-2 in the Theory of Operation section.) If the -9v signal is absent, use the ohmmeter to trace continuity to VR2 pin 2. |
| 17          | When the RESET switch is held, all address lights and data lights should be lit. All status lights except W0 should be lit if PRESET on the CPU board is connected to pin 14 of  | If the correct LEDs are lit, proceed to Section 4-4 (if problems exist with the RUN/STOP, SINGLE STEP/SLOW or PROTECT/UNPROTECT switches). Then proceed to Section 4-5 | If pin 2 of IC F on the CPU board does not go LOW with RESET, a problem exists in the RESET circuitry; proceed to Section 4-4. When the RESET switch is pressed and pin 2 goes LOW, pin 1 of IC F should go HIGH. If not, check IC F according to the instructions on page 4-5. A HIGH at pin 1   |

Step

Instructions

IC K. (Note: If the pins of IC M on the CPU board are HIGH, the corresponding LEDs on the front panel should be lit.)

If Correct

If problems exist with the EXAMINE/EXAMINE NEXT, DEPOSIT/DEPOSIT NEXT, ACCUMULATOR DISPLAY/ACCUMULATOR LOAD, or IN/OUT switches.

If Incorrect

of IC F should cause a HIGH at pin 12 of IC M. If not, check continuity and repair as necessary. If any of the address lights or data lights are not lit when the RESET switch is held, the problem may be due to shorts or defective LEDs. RESET should cause all data lines (D0-D7) and address lines (A0-A15) from IC M on the CPU board to go HIGH. If any of these lines fail to go HIGH when pin 12 of IC M is HIGH, check for shorts and repair as necessary. If any of the address or data lights are unlit when RESET is lifted, start at the corresponding pin of IC M on the CPU board and trace the levels through the Interface board to the Display/Control board. The address lights correspond to A0-A15 (IC M pins 25, 26, 27, 1, 29-40) and the data lights correspond to D0-D7 (IC M pins 3-10).  
To trace the data lines (D0-D7), pins 1 and 15 of both ICs D and E on the CPU board should be LOW. If pin 1 is not LOW, trace continuity to pin 3 of VR1. If pin 15 is not LOW, trace logic to a LOW at pin 17 of IC M on the CPU board. If pin 17 is not LOW, check IC M according to the instructions on page 4-20, step 6. If the inputs of ICs D and E do not match the outputs, D and E should be checked according to the instructions on page 4-5.



StepInstructionsIf CorrectIf Incorrect

Trace the logic levels of ICs Y and P to IC G on the Interface board. Pins 2, 13 and 14 of IC G should be HIGH to allow data to pass through. Check any suspected ICs according to the instructions on page 4-5.

Refer to schematic 3-16 (sheet 3 of 3), and check the anode lead of the suspected LED for +8v. If the voltage is absent, trace continuity to bus pin 1. Repair as necessary.

A LOW (less than .8v) output from open collector ICs H, K, M, D, B or F on the Display/Control board should produce a voltage of approximately 5v at the cathode lead of the corresponding LED. If this voltage is absent, check for shorts. Check for Vcc and Ground to the open collector IC. If absent, check continuity. If Vcc and Ground are present, check the LED before replacing the IC. A lower voltage (5v) should cause the LED to light; if the LED remains unlit, turn power off and unsolder the LED. Refer to Figure 5-23 on page 5-34 for orientation and install the LED in place of a working (lit) LED. If the LED does not light when power is returned and the RESET switch is lifted, the LED is defective and should be replaced.

Waveform #1 shows the clock inputs to the 3080A microprocessor chip itself.

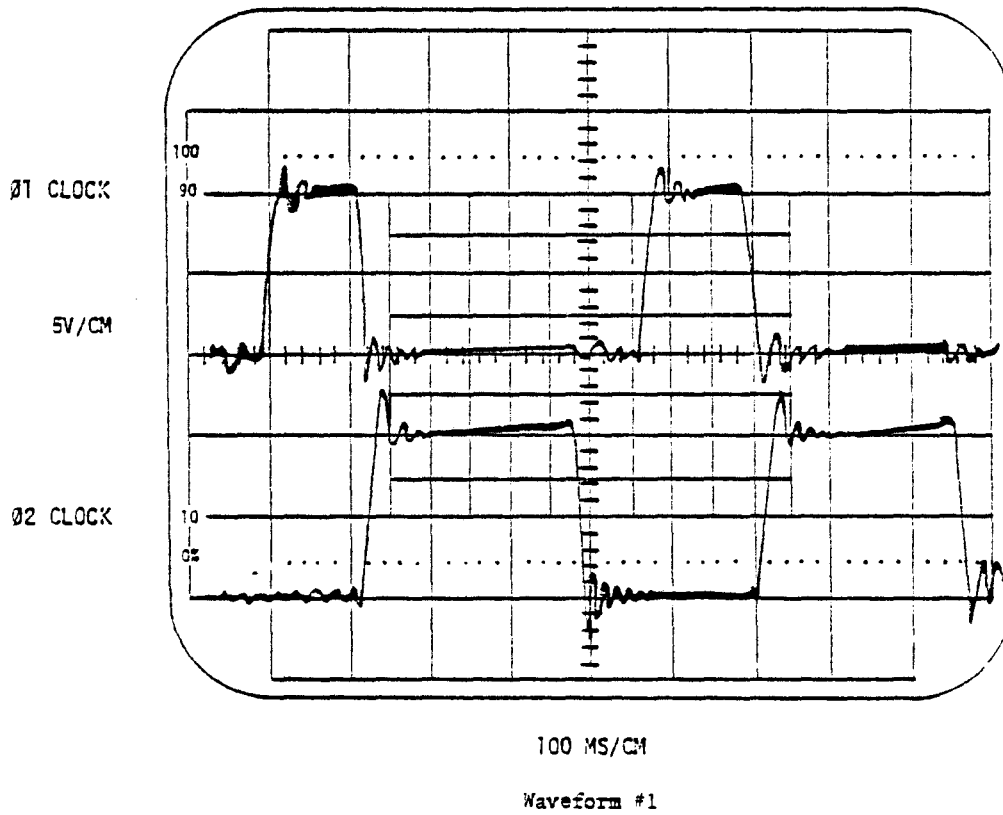

Waveforms 2 and 3 show  $\phi 1$  and  $\phi 2$  signals on the bus.

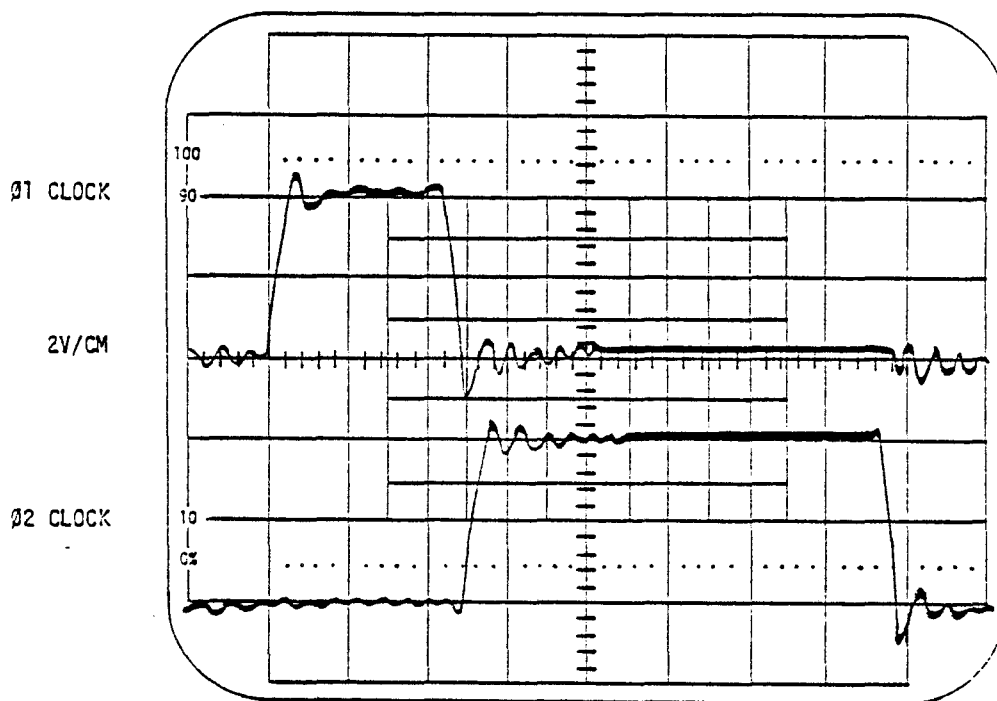

50 MS/CM

Waveform #2

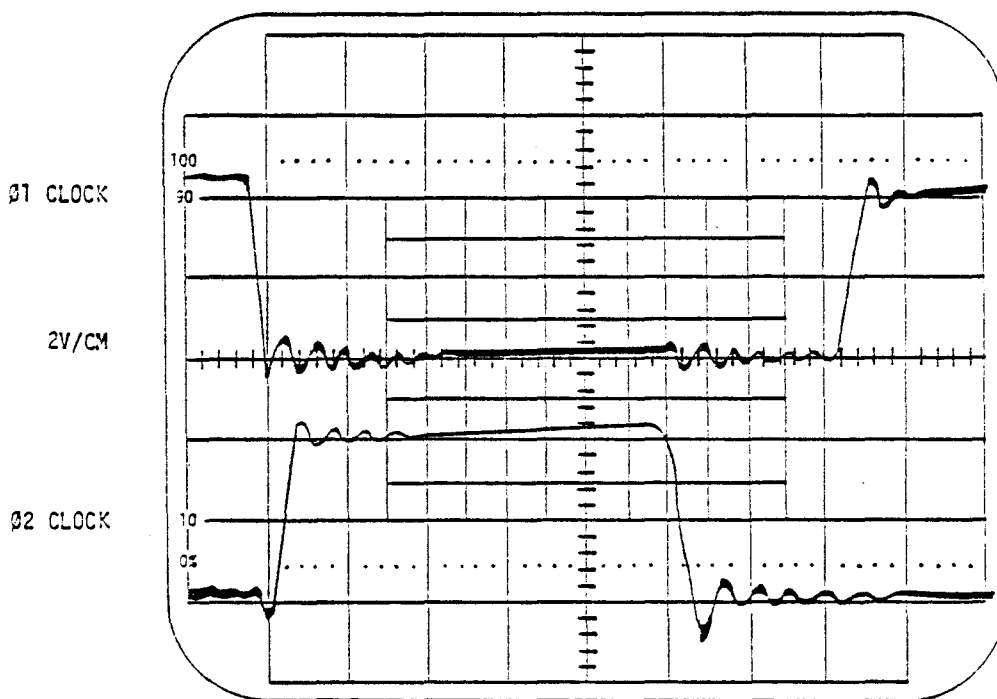

50 MS/CM

Waveform #3

Waveform #4 shows the  $\overline{C15}$  waveform on the D/C board for all conditions.

CT3 W 1-9  
2v/CM

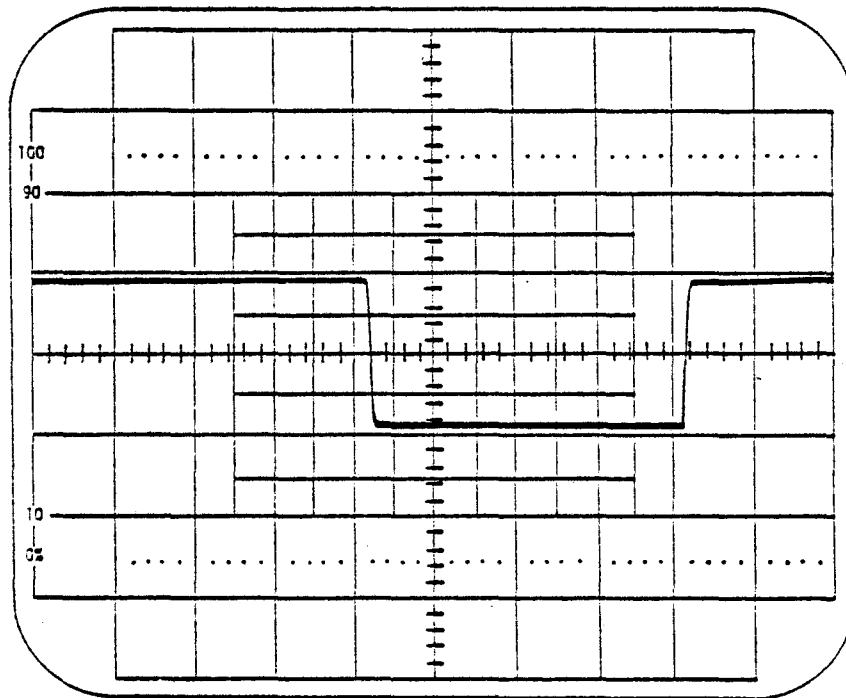

500 ns/CM

Wave form #4

Waveform #5 shows the C8 and CS waveforms on the D/C board for all conditions.

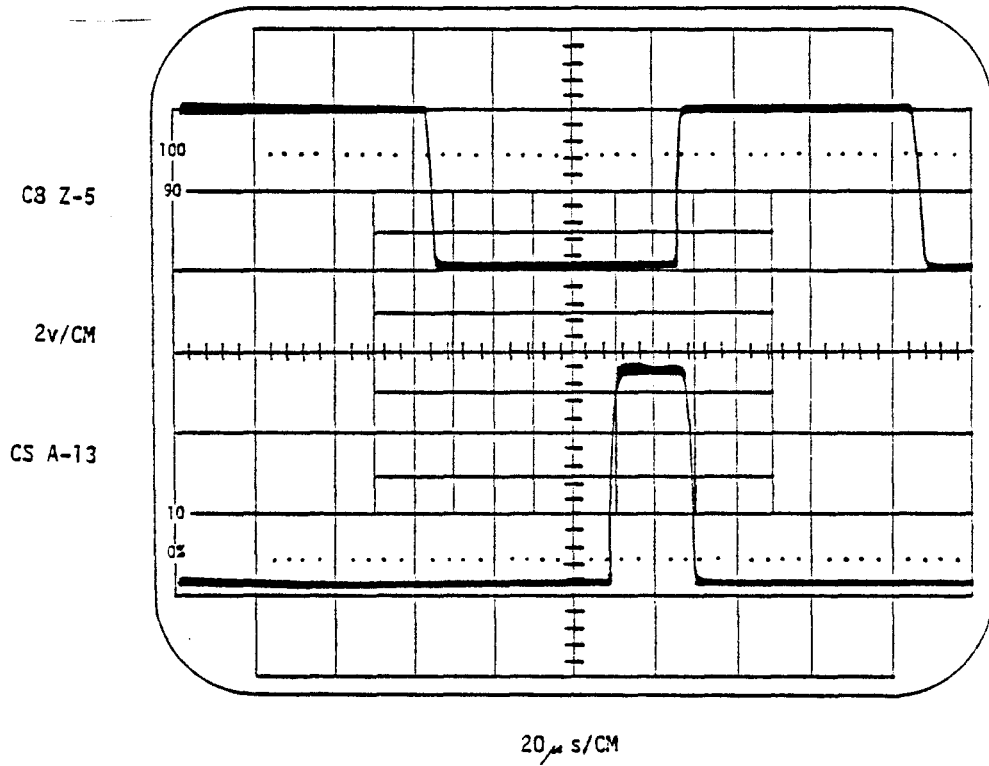

Waveform #5

Waveform #6 shows the  $\overline{C6}$  waveform on the D/C board for all conditions.

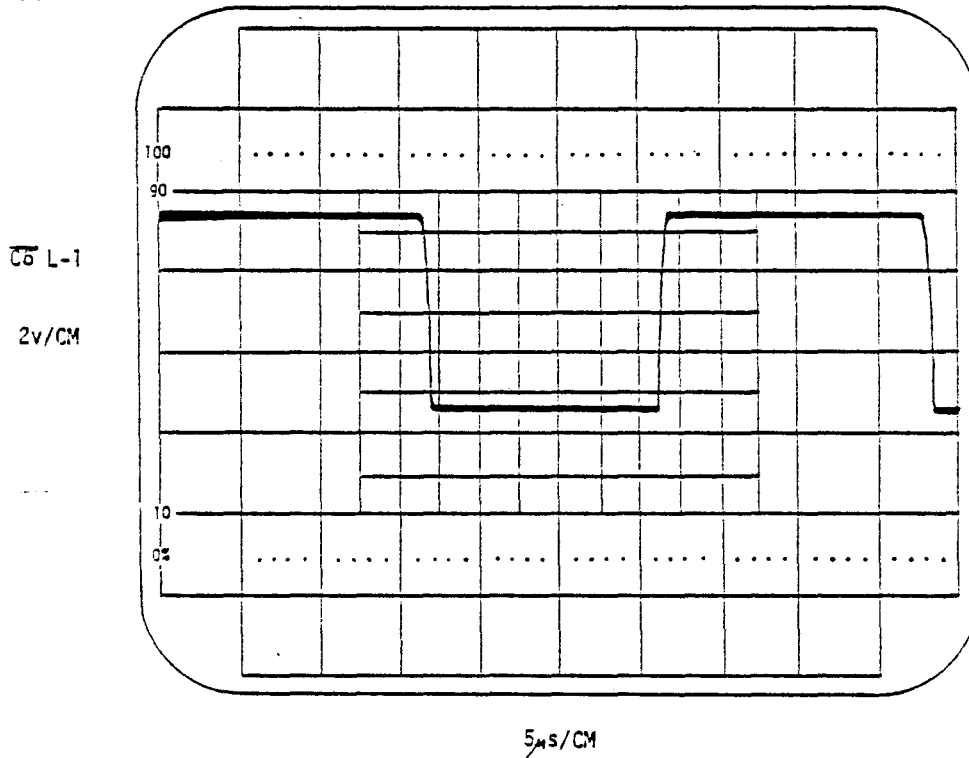

Waveform #6

#### 4-4. NON-PROM RELATED SWITCH PROBLEMS

Section 4-4 contains tests for the RESET, STOP, RUN, SINGLE STEP/SLOW, PROTECT/UNPROTECT, SENSE and STATUS circuitry. If problems involving the PROM related switches also exist, solve the non-PROM related switch problems first.

Table 4-4. Reset Check

## Problem

Description: During proper operation, lifting the RESET switch should cause all data and address lights to go HIGH whether the computer is running or not. If this does not occur, follow the steps below.

| <u>Step</u> | <u>Instructions</u>   | <u>If Correct</u>  | <u>If Incorrect</u>  |
|-------------|---|--|--|
| 1           | Press the RESET switch and check IC G1 pin 4 and IC W1 pins 5 and 7 on the Display/Control board.   | Pin 4 of IC G1 should go LOW. Pins 5 and 7 of IC W1 should go HIGH. Proceed to Step 2. | If pin 4 fails to go LOW, check the RESET switch with an ohmmeter and replace if necessary. If pins 5 and 7 fail to go HIGH, check ICs W1 and G1 according to the instructions on page 4-5. Trace continuity from pin 1 of ICs W1 and G1 to VR1 pin 2. If absent, repair as necessary. |
| 2           | Trace the HIGH level of IC W1 pin 7 through ICs R and N on the Interface board to bus pin 75 (which should be LOW when the RESET switch is lifted). | If proper logic operation is present, proceed to Step 3.                               | If ICs R and N do not follow their respective truth tables, check them according to the instructions on page 4-5. With an ohmmeter, check continuity from the Display/Control board to the Interface board. If opens are found, repair as necessary.                                   |
| 3           | A LOW PRESET signal should produce a LOW at IC F pin 2 on the CPU board.  | If present, proceed to Step 4.   | If a LOW is not present at IC F pin 2, check for proper logic operation through ICs G and B on the CPU board. Check any IC that does not follow its truth table according to the instructions on page 4-5.   |
| 4           | A LOW input at IC F pin 2 should produce a HIGH at IC M pin 12 on the CPU board.  | If present, proceed to Step 5.   | Check IC F for +5v at pin 16, +12v at pin 9 and Ground at pin 8. If absent or incorrect, trace continuity to VR1 pin 2, VR2 pin 2 and bus pin 1, respectively. If continuity is present, check IC F according to the instructions on page 4-5, and replace if necessary.               |

| <u>Step</u> | <u>Instructions</u>   | <u>If Correct</u>     | <u>If Incorrect</u>  |
|-------------|---|-----------------------|--|
| 5           | A HIGH signal at pin 12 of IC M on the CPU board should cause all address and data lines to go HIGH. (The LEDs corresponding to the address and data lines should light.) | Proceed to Table 4-5. | If any of the address (A0-A15) or data (D0-D7) lines fail to go HIGH, check for shorts. If the address and data lights do not light when the corresponding pin of IC M (on the CPU board) is HIGH, refer to Section 4-3, Step 17 on page 4-24. |



Table 4-5. Stop Check

## Problem

Description: Normal Operation--When the computer is running, the Wait light should be off or dim and several address lights should be dim. The Ready line will be HIGH on pin 23 of IC M on the CPU board. When the computer is stopped, only status lights M1, MEMR and WAIT should be on. Pin 23 of IC M will be LOW. There should be no change in the address lights. If the computer cannot be stopped, proceed with the steps below.

| <u>Step</u> | <u>Instructions</u>  | <u>If Correct</u>  | <u>If Incorrect</u>  |
|-------------|--|--|--|
| 1           | Check the logic operation from IC R1 on the Display/Control board to IC M on the CPU board. A LOW signal at IC R1 pin 12 should cause a HIGH at pin 23 of IC M on the CPU board. Check for proper logic operation at IC P1 on the Display/Control board. | If logic to the Display/Control board is correct, the problem lies in either one of two areas: the RUN/STOP circuitry or the SS Control circuitry. Check pins 12 and 13 of IC P1 on the Display/Control board. A constant LOW on pin 12 indicates a problem in the RUN/STOP circuitry. Irregular LOW going pulses at pin 13 of IC P1 indicate a problem in the SS Control circuitry. To test for RUN/STOP problems, proceed to Step 2 on page 4-35. To test for SS Control problems, proceed to Step 3 on page 4-39. | Trace the logic levels from IC R1 on the Display/Control board through ICs R and H on the Interface board. Pin 12 of IC R1 should be LOW and bus pin 58 should be HIGH. If not, check ICs R and H according to the instructions on page 4-5. A LOW at bus pin 58 should produce a HIGH at IC F pin 3 on the CPU board. If this HIGH signal is absent at pin 3, check ICs C and B on the CPU board according to the instructions on page 4-5. The HIGH at IC F pin 3 should produce a HIGH at IC M pin 23. If not, check IC F pins 16, 9 and 8. Pin 16 should read +5v; pin 9, +12v; and pin 8, Ground. If the procedures on this page have solved the problem, proceed to Table 4-5 on page 4-43. If the problem still exists, proceed to Step 2 on page 4-35. |

| <u>Step</u> | <u>Instructions</u>  | <u>If Correct</u>         | <u>If Incorrect</u>   |
|-------------|--|---------------------------|---|
| 2           | <p>RUN/STOP Circuitry.</p> <p>A. If a board was pulled out with power on, proceed with the steps below:</p> <ol style="list-style-type: none"><li>1) Turn the computer off and remove all boards. Test the mother board pins with an ohmmeter as described in Step 1 on page 4-15.</li><li>2) Inspect the mother board for opens along the lands corresponding to bus pins 1, 2 and 52.</li><li>3) Turn power on and check for proper voltages on the bus as described on page 4-15, step 2.</li><li>4) Pulling a board out while power is on usually damages the ICs connected to bus pins 3 and 53 which are shorted to bus pins 2 and 52. Check these ICs according to the instructions on page 4-15.</li></ol> | <p>Proceed to Step B.</p> | <p>Repair according to the instructions on page 4-15.</p> <p>Repair as necessary.</p> <p>If voltages are incorrect, repair according to the instructions on page 4-15.</p> <p>Replace IC C on the CPU board and IC N on the Interface board if necessary.</p> |

| <u>Step</u> | <u>Instructions</u>   | <u>If Correct</u>  | <u>If Incorrect</u>   |
|-------------|---|--|---|
| B.          | <p>Incorrect installation of Interface cables P1 and P2 can cause damage to several components. Refer to page 5-19 to check for improper cable assembly and repair if necessary. Then follow the steps below:</p> <ol style="list-style-type: none"><li>1) Check ICs H, K, B1 and T on the Display/Control board according to the instructions on page 4-5.</li><li>2) Turn power off and unsolder one lead of R74 on the Display/Control board. Test for a resistance reading of 2.2K ohms. Resolder the lead to the board.</li><li>3) Turn power on and check the +5v voltage regulator and the -9v voltage regulator on the Display/Control board as described on page 4-18, step 1.</li></ol> | <p>If P1 and P2 were correctly installed, proceed to Step C.</p> | <p>Replace as necessary.</p> <p>Replace as necessary.</p> <p>Repair according to the instructions on page 4-18.</p> |

| <u>Step</u> | <u>Instructions</u>  | <u>If Correct</u>                                       | <u>If Incorrect</u>   |
|-------------|--|---|---|
| C.          | Electrical Problem.  |   |   |
| 1)          | With the computer in a Run state, check for irregular HIGH pulses at IC M1 pin 3 on the Display/Control board. | If pulses are present, proceed to Step 2) on page 4-38. | If pulses are not present, check the logic from IC M1 to IC D1 on the Display/Control board. HIGH pulses should be present at pins 3, 4 and 5 of IC D1.<br>a. If pulses are missing from pin 3 (of IC D1), check pin 4 of IC M on the CPU board for positive pulses. If absent, check ICs M and F according to the instructions on page 4-20, Step 6. If pulses are present at IC M pin 4, check IC E pin 1 on the CPU board for a constant LOW signal. If absent, check continuity from pin 1 to Ground. Check pin 15 (of IC E) for a LOW PDBIN pulse. If pin 15 is HIGH, check IC V on the CPU board according to the instructions on page 4-5. If IC V is working properly, check pin 17 of IC M for LOW pulses. If absent, again check ICs M and F according to the instructions on page 4-20, step 6. Check pin 13 of IC E for a HIGH D05 signal. If present, trace continuity and logic to IC D1 on the Display/Control board. Repair as necessary.<br>b. If the PSYNC pulse is missing at pin 4 of IC D1, check for a HIGH pulse at pin 19 of IC M on the CPU board. If absent, check ICs F and M according to the instructions on page 4-5, |

StepInstructionsIf CorrectIf Incorrect

- 2) Lift the STOP switch and check pin 4 of IC C1, pin 5 of IC N1 and pin 2 of IC M1 on the Display/Control board.
- 3) Lift the STOP switch and check pins 4, 1 and 5 of IC M1.

C1 pin 4 should be LOW.  
N1 pin 5 should be HIGH.  
M1 pin 2 should be HIGH.  
Proceed to Step 3).

Pins 4 and 1 should be HIGH; pin 5 should be HIGH. Proceed to Step 3 on page 4-39.

step 6. If the HIGH pulse is present at pin 19, check continuity and logic from pin 19 to pin 4 of IC D1. Check ICs, if necessary, according to the instructions on page 4-5.

c. If the HIGH pulse (STSTB) is absent at pin 5 of IC D1 on the Display/Control board, check for a LOW pulse at pin 7 of IC F on the CPU board. If absent, check for a HIGH PSYNC signal at pin 5 of IC F. If absent, trace continuity to IC M pin 19. If continuity is present, check ICs F and M according to the instructions on page 4-20, step 6. If the LOW pulse is present at pin 7 of IC F, trace logic and continuity to pin 5 of IC D1 on the Display/Control board, and repair as necessary.

Pin 1 of ICs C1 and N1 should be HIGH. If not, trace continuity to Vcc, and repair as necessary. Check ICs C1, N1 and M1 according to the instructions on page 4-5. (Note: M1 pin 2 is HIGH only when the STOP switch is lifted and held.)

If pin 4 is LOW, check POC according to the instructions on page 4-22, step 11. If pin 1 of IC M1 is LOW, check IC P1 according to the instructions on page 4-5. Pin 1 of IC P1 should be LOW when the STOP switch is pressed. If not, check logic at pins 2 and 4 of IC N1 and at pins 5 and 6 of IC C1. If pin 5 of IC M1 is LOW, check pin

| <u>Step</u> | <u>Instructions</u>  | <u>If Correct</u>  | <u>If Incorrect</u>   |
|-------------|--|--|---|
| 3           | SS Circuitry.  |  | 2 for a HIGH. If absent, check the logic of ICs C1 and M1. If pin 2 is HIGH, check IC M1 according to the instructions on page 4-5.   |
| A.          | (Note: If the JE to JF Jumper is present on the Display/Control board, it should be removed for this check.) Check for LOW going clear pulses on IC M1 pin 13 on the Display/Control board while the chassis is in a Run state. A LOW at IC T1 pin 8 on the Display/Control board should produce the LOW clearing pulse at IC M1 pin 13. | If clear pulses are present on IC M, the trouble lies in the $\overline{SB}$ circuitry. Proceed to Step B. | If pulses are absent at M1 pin 13, check for proper logic at ICs J1 and T1 on the Display/Control board. If the PSYNC and/or STSTB signals are absent at the inputs of IC T1, refer to Step C on page 4-37. |
| B.          | If LOW $\overline{SB}$ pulses are present, follow the steps below:   |  |   |
| 1)          | Check pin 2 of IC J on the Display/Control board for a CS waveform (see waveform #5 on page 4-30).   | If present, proceed to Step 2).  | If absent, refer to Section 4-3, Step 13, page 4-23.  |
| 2)          | Check pin 13 of IC J for a constant LOW level.   | If absent, check pin 13 of IC A for a CS signal. If the signal is absent                                   | If a constant HIGH level is present at IC J pin 13, check continuity to pin 4 of IC A. Check IC A according to the instructions on page 4-5.  |

| <u>Step</u> | <u>Instructions</u>  | <u>If Correct</u>                                  | <u>If Incorrect</u>   |
|-------------|--|--|---|
|             |  | at IC A, refer to Section 4-3, Step 13, page 4-23. |   |
|             | 3) Check pins 2, 11 and 14 of IC A on the Display/Control board for HIGH signals.                        | If present, proceed to Step 4).                    | If absent, trace continuity to VR1 pin 2 and repair as necessary.   |
|             | 4) Trace continuity from pin 1 of IC J to pin 1 of IC A and to pins 12 and 1 of IC P.                    | If continuity is present, proceed to Step C.       | Repair as necessary.  |
| C.          | Check pin 14 of IC P on the Display/Control board for a CB signal.                                       | If present, proceed to Step D.                     | If absent, refer to Section 4-3, Step 15, page 4-24. Check the logic operation of IC Z.   |
| D.          | Check for a HIGH at IC P pin 3 on the Display/Control board.   | If present, proceed to Step E.                     | If absent, trace continuity through R49 to VR1 pin 2 (on the Display/Control board). Repair as necessary.   |
| E.          | Check pin 2 of IC P for a LOW level. Pin 2 should pulse HIGH only when a PROM related switch is pressed. | If present, proceed to Step F.                     | If absent, check for HIGH $\overline{RC-CLR}$ and $\overline{POC}$ levels at pins 12 and 13 of IC Z. If $\overline{POC}$ is LOW, refer to Section 4-3, Step 7, page 4-20. A LOW signal at $\overline{RC-CLR}$ indicates either no $\overline{C6}$ signal at IC L1 pin 1 on the Display/Control board (refer to Section 4-3, Step 14, page 4-24) or LOW going pulses on pin 3 of IC L1. LOW pulses at IC L1 pin 3 should occur only when a PROM related switch is pressed. Check for HIGHS at IC L1 pins 2 and 4. If absent, trace continuity to VR1 pin 2 and |

| <u>Step</u> | <u>Instructions</u>   | <u>If Correct</u>                                | <u>If Incorrect</u>   |
|-------------|---|--|---|
| F.          | A C8 signal at IC P pin 14 should cause HIGH going pulses to appear at pins 8, 9, 11 and 12 of IC P (RA0-RA13) on the Display/Control board. (Note: The C8 signal will occur only briefly when a PROM related switch is pressed.) | If HIGH pulses are present, proceed to Step G.   | repair as necessary.<br>If HIGH pulses are not present, check continuity from pin 1 to pin 12 of IC P. Check power and Ground at IC P. If present, turn power off and remove IC G. Turn power on and check again for pulses at pins 8, 9, 11 or 12. If absent, check IC P according to the instructions on page 4-5. Turn power off and reinstall IC G. |
| G.          | Check pins 17, 18, 19 and 20 of IC G on the Display/Control board for HIGHS. (LOWS should occur only when the appropriate PROM related switches are pressed.)   | If present, proceed to Step H.                   | If any LOW levels are present (but no PROM related switches are pressed), trace logic through ICs V1, Z1, U1, F1, Y1 and H1. Pin 1 of ICs F1, U1, H1 and Y1 should be LOW. If not, trace continuity to Vcc. Check and replace ICs if necessary.   |
| H.          | Check pins 1, 2, 3, 4, 5, 6, 11 and 12 of IC N on the Display/Control board for pulses.   | If present, proceed to Step I.                   | If constant levels rather than pulses are present, refer to Section 4-3, step 16 on page 4-24. Also check for shorts and bad socket connections.  |
| I.          | Check IC A1 pins 1 and 2 on the Display/Control board for proper inverting logic.   | If IC A1 is working properly, proceed to Step J. | If proper inverting logic is not present, check IC A1 according to the instructions on page 4-5.  |
| J.          | On the Display/Control board, compare the signal at IC A pin 1 to that of IC P pin 12.  | If the signals match, proceed to Step K.         | If the signals do not match, trace continuity to Vcc and repair as necessary.   |



StepInstructions

- K. Check for pulses at pins 3 and 4 of IC A.
- L. Check for a LOW at IC N pin 8 and trace logic to pin 4 of IC Z on the Display/Control board. A LOW at Z pin 4 should prevent the CB signal from appearing at pin 6 of IC Z and pin 14 of IC P and should keep IC P from incrementing. (Note: Pin 4 of IC Z should be LOW when the computer is stopped. Pin 4 should pulse HIGH only when a PROM related switch is pressed.)

If Correct

- If present, proceed to Step L.
- If a LOW is present at pin 8 of IC N and if proper logic is present, proceed to Table 4-6.

If Incorrect

- If pulses are absent at pin 3, trace continuity to pin 4 of IC G and repair as necessary. If the pulse is absent at pin 4 of IC A, turn power off and remove pin 4 from the board. Trace logic to pin 12 of IC J. If the pulse is present while pin 4 is removed from the board, trace continuity and look for shorts. If the pulse is absent while pin 4 is removed from the board, turn power off and replace IC A with either IC B1 or IC T. If pulses are now present at pins 3 and 4, IC A is defective and should be replaced.
- Check any ICs that do not follow their respective truth tables according to the instructions on page 4-5. Check for continuity and shorts from pin 12 of IC P to pin 2 of IC Z and repair as necessary.

Table 4-6. Run Check

Problem

Description: When the computer is running, the WAIT light on the front panel should be dim or off, and a HIGH should be present at pin 23 of IC M on the CPU board. If the computer will not run when the RUN switch is pressed, follow the steps below.

| <u>Step</u> | <u>Instructions</u>   | <u>If Correct</u>   | <u>If Incorrect</u>  |
|-------------|---|---|--|
| 1           | Press and hold the RUN switch and check for LOWs at ICs C1 pin 5 and M1 pin 2 on the Display/Control board. Check for HIGHs at ICs N1 pin 4 and P1 pin 1 (on the Display/Control board).  | If present, proceed to Step 2.                              | If absent, trace logic to the RUN/STOP switch. Check ICs C1 and N1 according to the instructions on page 4-5.  |
| 2           | The HIGH at pin 1 of IC P1 should produce a LOW at pin 1 of IC M1, causing a LOW at pin 5. A LOW at M1 pin 5 should produce a LOW at IC R1 pin 12. Trace this active LOW FRDY level through the Interface board to IC C pin 13 on the CPU board. (IC C pin 13 should be HIGH when the RUN switch is pressed.) The resulting HIGH at pin 3 of IC F should cause a HIGH at pin 23 of IC M (on the CPU board). | If proper logic operation is present, proceed to Table 4-7. | If a LOW is not present at pin 5 of IC M1, check the logic of IC P1 and, if necessary, check the ICs according to the instructions on page 4-5. Check for $\emptyset$ 2, Vcc and Ground at IC F. If IC F or IC M appears defective, refer to Section 4-3, Step 6, page 4-20. |

Table 4-7. Single Step/SLOW Check

## Problem

Description: If JE is jumpered to JF on the Display/Control board, SINGLE STEP/SLOW can be misleading. For example, when SINGLE STEP/SLOW is pressed for a JMP, a change cannot be detected in the LEDs. Activity can only be detected by monitoring pulses on IC M pin 23 (READY) on the CPU board. If pulses are not present at IC M, a problem exists in the SINGLE STEP/SLOW circuitry. Follow the steps below.

| <u>Step</u> | <u>Instructions</u>  | <u>If Correct</u>  | <u>If Incorrect</u>   |
|-------------|--|--|---|
| 1           | If SINGLE STEP will not function, follow steps A and B below:  |  |   |
|             | A. While pressing the SINGLE STEP switch, check for LOWs at ICs C1 pin 13 and D1 pin 1 on the Display/Control board. | If present, proceed to Step B.                                   | If absent, check for HIGH signals at pin 1 of ICs C1 and N1 on the Display/Control board. If absent, trace continuity to VR1 pin 2. If the HIGH signal is present, check ICs C1 and N1 according to the instructions on page 4-5. If IC D1 pin 2 is LOW, check pin 15 of IC N1 for a LOW. If absent, check pin 9 of ICs C1 and N1 for a $\overline{CT3}$ waveform. If the waveform is absent, refer to Section 4-3, Step 13, page 4-23. If pin 15 is HIGH, recheck the logic of ICs N1 and C1. Pin 13 of IC N1 should be HIGH. If not, trace continuity from pin 13 of IC D1 to pin 12 of IC J and repair as necessary. |
|             | B. When the SINGLE STEP switch is pressed and held, IC M1 pin 11 on the Display/Control board should go HIGH. Check  | If HIGH signals and proper logic are present, proceed to Step 2. | Check IC D1 according to the instructions on page 4-5. Check the logic from pin 8 of IC M1 on the Display/Control board to pin 23 of IC M on the CPU board. Check any suspected ICs according to  |

| <u>Step</u> | <u>Instructions</u>   | <u>If Correct</u>                                  | <u>If Incorrect</u>   |
|-------------|---|--|---|
|             | for HIGHS at pins 12, 10 and 13 of IC M1. (Note: A constant HIGH should be present at pin 13. A LOW pulse, however, will end the SINGLE STEP operation.) Trace the LOW pulse at IC M1 pin 8 to a HIGH pulse at pin 23 of IC M on the CPU board. |  | the instructions on page 4-5. If problems are suspected with IC F or IC M, refer to page 4-20, step 6.  |
| 2           | If SLOW (on the Display/Control board) will not function, follow steps A, B and C below:  |  |   |
|             | A. Check for C18 pulses at pin 10 of IC P1 on the Display/Control board.  | If present, proceed to Step B.                     | If absent, check the logic from pin 10 of IC P1 to jumper JD. (JD is located next to switch A1.) If pulses are not present at pins 2, 13 and 14 of IC X, refer to Section 4-3, steps 9 and 10 on page 4-22 to check ICs L and X. If pin 13 of IC D1 is LOW, check IC J pins 1, 2 and 13 as described in Table 4-5, Step 3, page 4-39. If pin 9 of IC P1 or pin 1 of IC D1 is LOW, check the logic of ICs C1 and N1. Check ICs C1 and N1 according to the instructions on page 4-5 if necessary. |
|             | B. Holding the SLOW switch down should produce HIGHS at pin 9 of IC P1 and at pins 1 and 13 of IC D1 on the Display/Control board.  | If present, proceed to Step C.                     | If LOW pulses are absent at pin 13 of IC M1, refer to step A on page 4-39. Any IC whose logic does not follow its truth table should be   |
|             | C. C18 pulses should occur at ICs D1 pin 2 and M1 pin 11 on the Display/Control   | If proper operation is present, proceed to Step 3. |   |

StepInstructions

board. LOW going pulses should be present at IC M1 pin 13. (Note: A constant LOW level should never be present at M1 pin 13.) Pins 12 and 10 of IC M should be HIGH. Trace the LOW going pulses at IC M1 pin 8 to the HIGH going pulses on the READY line (pin 23 of IC M on the CPU board).

3 If SINGLE STEP and SLOW will not actuate a stopped condition, follow steps A and B below:

- A. Pressing the SINGLE STEP/SLOW switch should produce LOWs at ICs M1 pin 2 and P1 pin 1 and HIGHs at ICs M1 pin 1 and P1 pin 12 on the Display/Control board. Check for a LOW going pulse at pin 13 of IC M1. (Note: This pulse may be hard to detect. If so, hit the RUN switch to produce several of these pulses

If Correct

If the proper signals are present, proceed to Step B.

If Incorrect

checked according to the instructions on page 4-5. HIGH pulses should be present at pin 3 of IC F on the CPU board. If ICs M or F appear defective, refer to Section 4-3, steps 5 and 6, page 4-20.

Check any IC whose logic does not follow its truth table according to the instructions on page 4-5. Pin 1 of ICs C1 and N1 should be HIGH. If not, trace continuity to VRI pin 2 and repair as necessary. If pin 13 of IC M1 is constantly LOW, refer to Step A, page 4-39.

Step

Instructions

If Correct

If Incorrect

B. Check pin 5 of IC T1 on the Display/Control board for a HIGH  $\overline{POC}$  signal. HIGH going pulses should be present at pins 3 and 4 of IC T1.

If present, proceed to Table 4-8.

If a HIGH  $\overline{POC}$  signal is not present at pin 5, refer to Section 4-3, step 11, page 4-22. If HIGH going pulses are absent at pins 3 and 4, check for PSYNC and STSTB pulses at pins 2, 13, 11 and 10 of IC T1. If these pulses are missing, trace logic to the CPU board according to the instructions on page 4-37, step C. Check any suspected ICs according to the instructions on page 4-5.

Table 4-8. Protect/Unprotect Check

Note 1: Table 4-8 deals with problems on the Display/Control board only; memory board problems are not included in this table.

Note 2: In order to perform the PROTECT/UNPROTECT check, one memory board that has the PROTECT/UNPROTECT option must be installed in the chassis. (16K Static boards do not have this function. PROM memory boards, when addressed, always cause the PROTECT LED to light.)

**Problem**

**Description:** If pressing the PROTECT switch does not protect the memory board from depositing new data and if the UNPROTECT switch does not allow new data to be deposited, follow the steps below.

| <u>Step</u> | <u>Instructions</u>   | <u>If Correct</u>                                  | <u>If Incorrect</u>   |
|-------------|---|--|---|
| 1           | Pressing the PROTECT (or UNPROTECT) should produce a LOW at pin 13 of IC G1 on the Display/Control board as long as the switch is held. Pressing the UNPROTECT switch causes the same operation to occur at pin 12 of IC G1. The LOW at pin 13 of IC G1 causes a LOW at pin 10 of IC W1 (for PROTECT). The LOW at pin 12 of IC G1 causes a LOW at pin 14 of IC W1 (for UNPROTECT). Trace the LOW active $\overline{\text{PROTECT}}$ (or UNPROTECT) signal to bus pin 20 (or 70). (Note: The memory board must be addressed in order to be protected.) | If proper operation is present, proceed to Step 2. | Check ICs G1 and W1 according to the instructions on page 4-5. Check any IC (on the Interface board) whose logic does not follow its truth table according to the instructions on page 4-5. |

Step

2

Instructions

A LOW on the PS line (bus #69) should cause the PROTECT LED to light.

If Correct

If so, proceed to Table 4-9 on page 4-50.

If Incorrect

If the PROTECT LED does not light, refer to Section 4-3, step 17 on page 4-24.



Table 4-9. Sense Switch Check

## Problem

Description: If the data input from the SENSE switches does not match the settings of A8-A15, follow the steps below.

| <u>Step</u>     | <u>Instructions</u>  | <u>If Correct</u>   | <u>If Incorrect</u>   |     |     |     |     |     |     |     |     |     |     |  |  |
|-----------------|--|---|---|-----|-----|-----|-----|-----|-----|-----|-----|-----|-----|--|--|
| 1               | Pressing Single Step twice for the following program should produce LOW levels at pins 8 and 9 of IC D on the Interface board. (Note: JE should <u>not</u> be jumpered to JF on the Display/Control board for this check.) All address lines (A0-A15) should be HIGH.  | If LOWs are present at pins 8 and 9 when the program is run, proceed to Step 2. | If LOW levels are not present at pins 8 and 9 of IC D, check the logic operation from IC M (A0-A15) on the CPU board to IC D on the Interface board. Check any suspected ICs according to the instructions on page 4-5. |     |     |     |     |     |     |     |     |     |     |  |  |
|                 | <table border="1"> <thead> <tr> <th><u>Location</u></th> <th><u>Bit Pattern</u></th> </tr> </thead> <tbody> <tr> <td>000</td> <td>333</td> </tr> <tr> <td>001</td> <td>377</td> </tr> <tr> <td>002</td> <td>303</td> </tr> <tr> <td>003</td> <td>000</td> </tr> <tr> <td>004</td> <td>000</td> </tr> </tbody> </table> | <u>Location</u>   | <u>Bit Pattern</u>  | 000 | 333 | 001 | 377 | 002 | 303 | 003 | 000 | 004 | 000 |  |  |
| <u>Location</u> | <u>Bit Pattern</u>   |   |   |     |     |     |     |     |     |     |     |     |     |  |  |
| 000             | 333  |   |   |     |     |     |     |     |     |     |     |     |     |  |  |
| 001             | 377  |   |   |     |     |     |     |     |     |     |     |     |     |  |  |
| 002             | 303  |   |   |     |     |     |     |     |     |     |     |     |     |  |  |
| 003             | 000  |   |   |     |     |     |     |     |     |     |     |     |     |  |  |
| 004             | 000  |   |   |     |     |     |     |     |     |     |     |     |     |  |  |
|                 | Note: If this program cannot be deposited, proceed to Table 11 on page 4-55 to correct the DEPOSIT problem.  |   |   |     |     |     |     |     |     |     |     |     |     |  |  |
| 2               | Pin 12 of IC J on the Interface board should be HIGH.  | If so, proceed to Step 3.   | If pin 12 is LOW, check IC D according to the instructions on page 4-5.   |     |     |     |     |     |     |     |     |     |     |  |  |
| 3               | Pin 13 of IC J should be HIGH. If not, check for a HIGH SINP signal at bus pin 46.   | If pin 13 of IC J is HIGH, proceed to Step 4.                                   | If pin 13 of IC J is not HIGH, check IC C according to the instructions on page 4-5. If the SINP signal is absent at bus pin 46, trace logic to pin 6 of IC K on the CPU board. Check                                   |     |     |     |     |     |     |     |     |     |     |  |  |

| <u>Step</u> | <u>Instructions</u>   | <u>If Correct</u>   | <u>If Incorrect</u>   |
|-------------|---|---|---|
| 4           | Pin 11 of IC J on the Interface board (SSWT) should be LOW. Checking logic and continuity, trace this signal to a LOW on pin 10 of IC Z on the Display/Control board. | If correct, proceed to Step 5.                                | any suspected ICs according to the instructions on page 4-5.<br>Check for HIGHS at pins 2, 11 and 13 of IC K. If absent, trace continuity to VRI pin 2 on the CPU board, and repair as necessary. Press RUN and check for LOW STSTB pulses on pin 1 of IC K (see Table 4-10, Step 3 on page 4-53).<br>Check the logic of ICs J and H on the Interface board. Check any suspected ICs according to the instructions on page 4-5. |
| 5           | For each address switch (A8-A15) that is lifted, the corresponding output pin of either IC W or IC U on the Display/Control board should be LOW.                      | If LOWs are present at the proper IC pins, proceed to Step 6. | If these IC pins are HIGH, check for shorts. Check ICs W and U according to the instructions on page 4-5.   |
| 6           | Trace the LOW level output from IC W or IC U to a HIGH on the corresponding output pin of IC E or IC M on the Interface board.  | If proper logic is present, proceed to Step 7.                | Check any suspected ICs according to the instructions on page 4-5.  |
| 7           | Check PDBIN (pin 2 of IC B on the Interface board and pin 4 of IC C on the CPU board) for HIGH levels.  | If present, proceed to Step 8.                                | If absent, check IC V on the CPU board according to the instructions on page 4-5. Trace logic to a HIGH at pin 17 of IC M on the CPU board. Check any suspected ICs according to the instructions   |

| <u>Step</u> | <u>Instructions</u>  | <u>If Correct</u>   | <u>If Incorrect</u>  |
|-------------|--|---|--|
| 8           | A LOW <u>SSWF</u> level should produce LOWs at pins 6 and 13 of IC B on the Interface board. Pin 8 of IC B should be HIGH, causing LOWs to appear at bus pin 57 (DIG1) and pin 6 of IC B. A LOW at pin 57 should produce a HIGH at pin 6 of IC C on the CPU board. Pins 4, 5, 9 and 10 of IC B should be HIGH. | If correct, proceed to Step 9.                            | on page 4-5.<br>If any of these signals are incorrect or absent, check continuity and check the ICs according to the instructions on page 4-5. If HIGHs are not present at IC B pins 4, 5, 9 and 10, trace continuity to VR1 pin 2 on the Interface board. |
| 9           | Refer to schematic 3-14. Lifting any of the A8-A15 address switches should cause the corresponding data line of ICs D, E and M on the CPU board to go HIGH.  | If the proper data lines are HIGH, proceed to Table 4-10. | Check logic from the outputs of ICs E and M on the Interface board to ICs D and E on the CPU board. Check any suspected ICs according to the instructions on page 4-5.   |

Table 4-10. Status Check

**Problem**

**Description:** If status is incorrect when the computer is turned on and if pressing the RESET switch fails to achieve proper status, follow the steps below.

| <u>Step</u> | <u>Instructions</u>   | <u>If Correct</u>   | <u>If Incorrect</u>   |
|-------------|---|---|---|
| 1           | Check for HIGHS at pins 2, 13, 11 and 14 of IC K on the CPU board.  | If present, proceed to Step 2.  | If pins 2, 13, 11 or 14 are LOW, trace continuity to VR1 pin 2 on the CPU board. Repair as necessary.   |
| 2           | PRESET should be HIGH on the bus.   | If so, proceed to Step 3.   | If not, check the logic for the RESET switch according to the instructions in Table 4, page 4-32.   |
| 3           | Check for a LOW going STSTB pulse at pin 1 of IC K on the CPU board while the computer is running.  | If present, proceed to Step 4.  | If absent, check continuity from pin 7 of IC F to pin 1 of IC K. If continuity is absent, check IC F on the CPU board according to the instructions in Table 5, Step C, page 4-38.  |
| 4           | Check for MEMR and M1 signals at IC K pins 4 and 8 on the CPU board. Check continuity from the outputs of ICs D and E to the inputs of IC K on the CPU board. | If present, proceed to Step 5.  | If pins 3 and 7 of IC K are constantly LOW when the computer is running, look for shorts on the CPU board and repair as necessary.  |
| 5           | If pins 4 and 8 of IC K are HIGH, the M1 and MEMR LEDs on the front panel should be lit.  | If the correct LEDs are lit, proceed to Section 4-5 if problems exist with the EXAMINE/EXAMINE NEXT, DEPOSIT/DEPOSIT NEXT, ACCUMULATOR DISPLAY/ ACCUMULATOR LOAD or IN/ OUT switches. | If the correct LEDs are not lit, check for proper logic operation from IC K on the CPU board to the front panel LEDs. Check any suspected ICs according to the instructions on page 4-5. If the ICs are working properly, refer to Step 17 on page 4-24 to check the LED circuitry. |

#### 4-5. PROM RELATED SWITCH PROBLEMS

Section 4-5 contains procedures to solve problems relating to the EXAMINE/EXAMINE NEXT, DEPOSIT/DEPOSIT NEXT, ACCUMULATOR DISPLAY/ACCUMULATOR LOAD and IN/OUT switches. Problems involving the RESET, RUN/STOP, SINGLE STEP/SLOW, PROTECT/UNPROTECT, SENSE and STATUS switches should be checked before performing the tests in Section 4-5. Refer to Section 4-4 to solve problems of this type.

The text in Section 4-5 is divided into 16 major steps. These are general procedures that should always be followed when testing the PROM related switches.

Table 4-11. PROM Related Switch Problems

Step  
1

Instructions

When a PROM related switch is pressed and held, the upper four bits (RA7-RA4) of the beginning address (as shown in Table 3-2 in the Theory of Operation section) are produced on the PROM (IC G on the Display/Control board) address lines. The chart below shows how the PROM address lines (RA7-RA4) correspond to the switch.

Address Bit

| Corresponding<br>PROM Pin | Address Bit |      |      |      |
|---------------------------|-------------|------|------|------|
|                           | RA7         | RA6  | RA5  | RA4  |
| Switch                    | 17          | 18   | 19   | 20   |
| EXAMINE                   | LOW         | HIGH | HIGH | HIGH |
| EXAMINE NEXT              | HIGH        | LOW  | HIGH | HIGH |
| DEPOSIT                   | HIGH        | HIGH | LOW  | HIGH |
| DEPOSIT NEXT              | HIGH        | HIGH | HIGH | LOW  |
| ACCUMULATOR<br>DISPLAY    | LOW         | LOW  | HIGH | HIGH |
| ACCUMULATOR<br>LOAD       | HIGH        | LOW  | LOW  | HIGH |
| IN                        | HIGH        | HIGH | LOW  | LOW  |
| OUT                       | HIGH        | LOW  | HIGH | LOW  |

If no PROM related switches are pressed, RA7-RA4 (pins 17-20 of IC G) should be HIGH.

If Correct

If RA7-RA4 go to the appropriate levels when the corresponding switch is pressed, proceed to Step 2.

If Incorrect

If RA7-RA4 are LOW when none of the switches are pressed, check for LOW Input signals at ICs V1 and Z1 on the Display/Control board. Trace continuity from RA4-RA7 through RP1 to VR1 pin 2 (Vcc), and repair as necessary. If a HIGH Input is found, check the logic operation of ICs F1, U1, A1 and V1. Pin 1 of ICs H1, U1, Y1 and F1 should be HIGH. If not, trace to VR1 pin 2 on the Display/Control board. Pins 4, 5, 13 and 12 of ICs F1 and H1 should be HIGH when none of the switches are pressed. If HIGH signals are not present, trace continuity to VR1 pin 2 and repair as necessary.

Press and hold down the suspected switch and trace logic to the switch from pins 17, 18, 19 and 20 of IC G on the Display/Control board. Check any suspected ICs according to the instructions on page 4-5.

| <u>Step</u> | <u>Instructions</u>  | <u>If Correct</u>   | <u>If Incorrect</u>  |
|-------------|--|---|--|
| 2           | Check for a HIGH clear pulse (less than .1 $\mu$ sec. wide) at pin 2 of IC P on the Display/Control board each time a PROM related switch is pressed. (Note: In order to better detect this pulse, turn the scope's time base to the lowest frequency setting, or highest time/cm setting, and turn up the intensity. A logic probe may also be needed.)   | If the pulse is present, proceed to Step 3.                         | If the pulse is absent, check for HIGHS at pins 2 and 4 of IC L and at pins 1, 2, 11 and 12 of IC X1 on the Display/Control board. If absent, trace continuity to VR1 pin 2 on the Display/Control board. Repair as necessary. Pressing any PROM related switch will cause at least one LOW on the input pins of IC X1, producing a HIGH at pin 3 of IC L1. The LOW going pulse at pin 6 ( $\overline{RC-CLR}$ ) of IC L1 should cause a HIGH pulse at pin 2 of IC P. At the same time, pin 5 (AL-STB) of IC L1 should pulse HIGH. If this does not occur, check ICs L1 and Z according to the instructions on page 4-5. |
| 3           | Refer to schematic 3-16, sheet 1 of 3. Press the PROM related switch and check for proper operation (as shown in schematic 3-16) on the RA0-RA3 address lines of IC G on the Display/Control board. For example, the DEPOSIT switch covers addresses 320-323. Address lines RA2 and RA3 (which correspond to pins 8 and 11, respectively, of IC P) are never used. Consequently, when the DEPOSIT switch is pressed, | If address lines RA0-RA3 are operating properly, proceed to Step 4. | If proper operation is not present at address lines RA0-RA3, check IC P according to the instructions in Table 4-5, Step F, on page 4-41.  |

Step

Instructions

pulses should not be present at pins 8 and 11 of IC P. When the switch is released, pulses may be present at all outputs of IC P. The following chart shows the correct pulse level for each switch.

| <u>Switch</u>          | <u>Address Bit</u> |            |            |            |
|------------------------|--------------------|------------|------------|------------|
|                        | <u>RA3</u>         | <u>RA2</u> | <u>RA1</u> | <u>RA0</u> |
| EXAMINE                | NP                 | P          | P          | P          |
| EXAMINE<br>NEXT        | NP                 | NP         | P          | P          |
| DEPOSIT                | NP                 | NP         | P          | P          |
| DEPOSIT<br>NEXT        | NP                 | P          | P          | P          |
| ACCUMULATOR<br>DISPLAY | P                  | P          | P          | P          |
| ACCUMULATOR<br>LOAD    | P                  | P          | P          | P          |
| IN                     | P                  | P          | P          | P          |
| OUT                    | P                  | P          | P          | P          |

NP = No pulses

P = Pulses

(Note: This chart is valid only when the switch is pressed and held. When the switch is released, pulses may appear at all of the address lines.)

If Correct

If Incorrect



StepInstructionsIf CorrectIf Incorrect

4

For each data line, check continuity (with an ohmmeter set at X1K or higher) from the output pins of ICs N and F on the Interface board to the appropriate pins of ICs D and E on the CPU board.

If continuity is present, proceed to Step 5.

If continuity is absent, check for opens or a bad connection in the CPU to Interface board cable. An open will cause the same bit to be deposited no matter what condition the A0-A7 switches are in. The EXAMINE switch will show that the address bit is HIGH along with the corresponding bit in addresses A8-A15. Resolder the cable if necessary and solder over opens. If the correct number of pulses is not present at IC M1 pin 11, check IC G on the Display/Control board. Also check CS, C8, C13, C6 and M1 (refer to pages 4-23 step 13, 4-24 step 15, 4-22 step 10, 4-24 step 14 and 4-37 step C, respectively).

5

If a pulse counter is available, check for the appropriate number of clock pulses at IC M1 pin 11 on the Display/Control board as listed below:

If correct, proceed to Step 6.

| <u>Switch</u>          | <u>Number of Pulses</u> |
|------------------------|-------------------------|
| EXAMINE                | 3                       |
| EXAMINE NEXT           | 1                       |
| DEPOSIT                | 0                       |
| DEPOSIT NEXT           | 1                       |
| ACCUMULATOR<br>DISPLAY | 6                       |
| ACCUMULATOR<br>LOAD    | 6                       |
| INPUT                  | 6                       |
| OUTPUT                 | 6                       |

(Note: Each number corresponds to the number of S8 pulses set in Table 3-2.)

| <u>Step</u> | <u>Instructions</u>   | <u>If Correct</u>  | <u>If Incorrect</u>  |
|-------------|---|--|--|
| 6           | If the $\overline{CT3}$ , $\overline{C6}$ , C8 and C5 signals have not been checked, refer to page 4-22 step 10, page 4-24 step 14, page 4-24 step 15, and page 4-23 step 13, respectively, to check these signals.   | If these signals are functioning properly, proceed to Step 7.  | Repair according to the instructions on the appropriate page.  |
| 7           | The PROM functions usually cause each PROM data output to change levels at least once. Bit 7 of EXAMINE NEXT is the only exception to this rule. Press each PROM related switch while monitoring the output pins of IC G on the Display/Control board for pulses. | If constant levels are not present, proceed to Step 8.         | If a constant LOW or HIGH signal is present on pins 4, 5, 6, 7, 8, 9, 10 or 11 of IC G on the Display/Control board when a switch is pressed, check continuity with an ohmmeter and look for shorts and bad socket connections. Repair as necessary. |
| 8           | Check for HIGH signals at pins 2, 14 and 11 of IC A on the Display/Control board. Check continuity from pins 1 and 12 of IC P to pin 1 of IC A and to pin 2 of IC Z on the Display/Control board.   | If HIGH signals and continuity are present, proceed to Step 9. | If HIGH signals and/or continuity are absent, check continuity from the suspected pin to VRI pin 2 on the Display/Control board and repair as necessary.   |
| 9           | One second after the switch is pressed, the final address (as shown in Table 3-2) should appear on lines RA0-RA7 and remain there until the switch  | If correct, proceed to Step 10.                                | If the final address is not 177, check IC G according to the instructions on page 4-24, step 16. Also look for shorts and repair as necessary.   |

| <u>Step</u>         | <u>Instructions</u>  | <u>If Correct</u>               | <u>If Incorrect</u>  |         |                    |              |            |         |            |              |                    |                     |                    |                  |                          |    |                           |     |                           |  |  |
|---------------------|--|---------------------------------|--|---------|--------------------|--------------|------------|---------|------------|--------------|--------------------|---------------------|--------------------|------------------|--------------------------|----|---------------------------|-----|---------------------------|--|--|
|                     | is released. 177 should also be present at IC G on the Display/Control board.  |                                 |  |         |                    |              |            |         |            |              |                    |                     |                    |                  |                          |    |                           |     |                           |  |  |
| 10                  | Refer to the following chart and check for S pulses at pins 4, 6, 8, 10, 15, 17, 19 or 21 of IC A on the Display/Control board.  | If present, proceed to Step 11. | If the proper pulses are absent, or if the improper pulses are present at IC A, check IC A according to the instructions on page 4-5. Also look for shorts and repair as necessary.            |         |                    |              |            |         |            |              |                    |                     |                    |                  |                          |    |                           |     |                           |  |  |
|                     | <table border="1"> <thead> <tr> <th><u>Switch</u></th> <th><u>S Pulse</u></th> </tr> </thead> <tbody> <tr> <td>EXAMINE</td> <td>S1, S2, S5, S7, S8</td> </tr> <tr> <td>EXAMINE NEXT</td> <td>S5, S7, S8</td> </tr> <tr> <td>DEPOSIT</td> <td>S1, S6, S7</td> </tr> <tr> <td>DEPOSIT NEXT</td> <td>S1, S6, S7, S8, S5</td> </tr> <tr> <td>ACCUMULATOR DISPLAY</td> <td>S3, S4, S5, S7, S8</td> </tr> <tr> <td>ACCUMULATOR LOAD</td> <td>S1, S3, S4, S5, S7<br/>S8</td> </tr> <tr> <td>IN</td> <td>S2, S3, S4, S5, S7,<br/>S8</td> </tr> <tr> <td>OUT</td> <td>S2, S3, S4, S5, S7,<br/>S8</td> </tr> </tbody> </table> | <u>Switch</u>                   | <u>S Pulse</u>   | EXAMINE | S1, S2, S5, S7, S8 | EXAMINE NEXT | S5, S7, S8 | DEPOSIT | S1, S6, S7 | DEPOSIT NEXT | S1, S6, S7, S8, S5 | ACCUMULATOR DISPLAY | S3, S4, S5, S7, S8 | ACCUMULATOR LOAD | S1, S3, S4, S5, S7<br>S8 | IN | S2, S3, S4, S5, S7,<br>S8 | OUT | S2, S3, S4, S5, S7,<br>S8 |  |  |
| <u>Switch</u>       | <u>S Pulse</u>   |                                 |  |         |                    |              |            |         |            |              |                    |                     |                    |                  |                          |    |                           |     |                           |  |  |
| EXAMINE             | S1, S2, S5, S7, S8   |                                 |  |         |                    |              |            |         |            |              |                    |                     |                    |                  |                          |    |                           |     |                           |  |  |
| EXAMINE NEXT        | S5, S7, S8   |                                 |  |         |                    |              |            |         |            |              |                    |                     |                    |                  |                          |    |                           |     |                           |  |  |
| DEPOSIT             | S1, S6, S7   |                                 |  |         |                    |              |            |         |            |              |                    |                     |                    |                  |                          |    |                           |     |                           |  |  |
| DEPOSIT NEXT        | S1, S6, S7, S8, S5   |                                 |  |         |                    |              |            |         |            |              |                    |                     |                    |                  |                          |    |                           |     |                           |  |  |
| ACCUMULATOR DISPLAY | S3, S4, S5, S7, S8   |                                 |  |         |                    |              |            |         |            |              |                    |                     |                    |                  |                          |    |                           |     |                           |  |  |
| ACCUMULATOR LOAD    | S1, S3, S4, S5, S7<br>S8   |                                 |  |         |                    |              |            |         |            |              |                    |                     |                    |                  |                          |    |                           |     |                           |  |  |
| IN                  | S2, S3, S4, S5, S7,<br>S8  |                                 |  |         |                    |              |            |         |            |              |                    |                     |                    |                  |                          |    |                           |     |                           |  |  |
| OUT                 | S2, S3, S4, S5, S7,<br>S8  |                                 |  |         |                    |              |            |         |            |              |                    |                     |                    |                  |                          |    |                           |     |                           |  |  |
| 11                  | The S pulses listed in Step 10 should produce the following results:   |                                 |  |         |                    |              |            |         |            |              |                    |                     |                    |                  |                          |    |                           |     |                           |  |  |
|                     | A. For each A0-A7 switch that is up, S1 should produce a HIGH pulse on the corresponding output pin of IC E  | If present, proceed to Step B.  | If these HIGH pulses are absent, trace continuity from pin 21 of IC A to the input pins of ICs Y and W on the Display/Control board. Also trace continuity from the output pins of ICs Y and W |         |                    |              |            |         |            |              |                    |                     |                    |                  |                          |    |                           |     |                           |  |  |

| <u>Step</u> | <u>Instructions</u>   | <u>If Correct</u>   | <u>If Incorrect</u>   |
|-------------|---|---|---|
|             | or IC M on the Interface board.<br>To check for S1, press the DEPOSIT switch.   |   | to the input pins of ICs E and M on the Interface board with the corresponding switch up. Repair as necessary. Check logic operation from the input pins of ICs Y and W on the Display/Control board to the output pins of ICs E and M on the Interface board. Check any suspected ICs according to the instructions on page 4-5. |
| B.          | A HIGH S2 pulse should cause LOW pulses at the outputs of ICs W and U on the Display/Control board (if the corresponding switch is up). | If LOW pulses are present, proceed to Step C.                             | If LOW pulses are absent, check the logic of ICs A1, Z, W and V. Test the ICs according to the instructions on page 4-5, if necessary.  |
| C.          | HIGH S3 and S4 pulses should produce HIGHS at ICs B1 pin 13 and T pin 13 on the Display/Control board.                                  | If HIGH signals are present at B1 pin 13 and T pin 13, proceed to Step D. | If HIGH pulses are absent, check continuity with an ohmmeter and repair as necessary.   |
| D.          | A HIGH S5 pulse should produce LOWs at IC R pins 1 and 15 and IC S pin 1 on the Display/Control board.                                  | If LOW signals are present, proceed to Step E.                            | If LOW signals are absent, check continuity from pin 10 of IC A to pin 9 of IC A1 on the Display/Control board. If the logic on IC A1 is incorrect, check the IC according to the instructions on page 4-5.   |
| E.          | A HIGH S6 pulse should produce a HIGH MWRITE pulse at bus pin 68 and a HIGH DIG1 pulse at bus pin 57.                                   | If HIGH pulses are present, proceed to Step F.                            | If a HIGH MWRITE pulse is absent at bus pin 68, check for a LOW $\overline{DEP}$ pulse at pin 8 of IC J. If absent, check pin 10 of IC J on the Display/  |

StepInstructions

If the MWRITE signal is absent, "1's" will appear in the data lights (for each A0-A7 switch that is up) for as long as the DEPOSIT switch is held. When the DEPOSIT switch is released, the data lights will return to their original pattern. The DEPOSIT NEXT switch will act as EXAMINE NEXT, i.e. it will increment an address, but fail to deposit it in memory.

- F. A HIGH S7 pulse should produce LOWs at IC F pins 1 and 15 and IC N pin 15 on the Interface board, and a HIGH at pin 6 of IC C on the CPU board.

If Correct

If present, proceed to Step G.

If Incorrect

Control board when the switch is pressed. If absent, check continuity from pin 10 of IC J to pin 13 of IC A, pin 2 of IC Z, and pins 12 and 1 of IC P. Repair as necessary. Pins 2 and 14 of IC A should be HIGH. If not, trace continuity to Vcc. If the  $\overline{DEP}$  pulse is still absent, check IC J according to the instructions on page 4-5. If IC J is working properly, and if continuity is present, check ICs A and H on the Interface board for proper logic operation.

If a HIGH DIG1 pulse does not occur at bus pin 57, trace logic from IC C pin 5 on the Display/Control board to a LOW pulse at pins 6 and 12 of IC B on the Interface board. Trace the HIGH pulse from IC B pin 8 to a HIGH at pin 6 of IC C on the CPU board. Pin 2 of IC B should pulse HIGH simultaneously with IC C pin 6. If not, check the logic from pin 2 of IC B to pin 17 of IC M on the CPU board. Check the ICs, if necessary, according to the instructions on page 4-5.

If absent, check for a CS signal at pin 4 of IC J and for HIGH pulses from IC P pin 12 to pin 5 of IC J on the Display/Control board. If the signals are absent, trace continuity and repair as necessary. Trace logic to IC B pin 12 on the Interface board. Pins 4, 5, 9, 10, 13 and 2 of IC B

Step

Instructions

If Correct

If Incorrect

should be HIGH. If pins 4, 5, 9 or 10 are LOW, trace continuity to VR1 pin 2 on the Interface board. If pin 2 of IC B is LOW, trace logic and continuity to pin 17 of IC M. IC M pin 17 should be HIGH. If not, look for shorts and check IC V according to the instructions on page 4-5. If pin 13 of IC B is LOW, check IC J on the Interface board according to the instructions on page 4-5. Pins 12 and 13 of IC J should be LOW. If not, check ICs C and D on the Interface board according to the instructions on page 4-5. S7 should produce a LOW pulse at pin 12 of IC B, causing a HIGH pulse at pin 1 (of IC B). If a HIGH pulse is not present at pin 1, check IC B according to the instructions on page 4-5. Trace the HIGH pulse from IC B pin 1 to IC C pin 5 on the CPU board. (Pin 4 of IC C should be HIGH.) Absence of a LOW pulse at pin 6 of IC B will cause all "1's" to be deposited into memory (no matter how the A0-A7 switches are set) when the DEPOSIT switch is pressed. Pressing the EXAMINE switch will cause HIGHS only at A3, A4 and A5 (no matter how the A0-A15 switches are set), since the CPU receives an RST 7 (377) instruction and jumps to location 070.

StepInstructionIf CorrectIf Incorrect

G. A HIGH SB pulse should produce a HIGH READY pulse on pin 23 of IC M on the CPU board.

If present, proceed to Step 12.

If the READY pulse is absent at pin 23, check for a HIGH pulse (from IC P) at pin 1 of IC J on the Display/Control board and for a CS signal at pin 2 (of IC J). If the pulse is absent at pin 1, check continuity to pins 1 and 12 of IC P. Repair as necessary. If the CS signal is absent at pin 2, refer to Step 13 on page 4-23. Trace logic from pin 12 of IC J to a HIGH pulse on pin 11 of IC M1. Check any suspected ICs according to the instructions on page 4-5. Pins 12 and 10 of IC M1 should be HIGH. If not, trace continuity to Vcc. Pin 13 of IC M should be HIGH. If a constant LOW is present, check logic at ICs J1 and T1 and replace, if necessary. Trace logic from IC M1 pin 8 to IC M on the CPU board. Replace ICs and repair shorts or opens if necessary. If ICs M or F appear defective, refer to Section 4-3, Step 6 on page 4-20.

12

Check the DEPOSIT switch for proper operation; it should deposit each bit separately.

Proceed to Step 13.

If the switch cannot deposit the bits separately, try different bit combinations. A bit that cannot be deposited separately may be dependent on another bit; check for shorts with an ohmmeter set at X1K or higher. A LOW resistance reading between two data lines indicates a short. Repair as necessary.

| <u>Step</u> | <u>Instructions</u>  | <u>If Correct</u>   | <u>If Incorrect</u>   |
|-------------|--|---|---|
| 13          | Lower address switches A8-A15 in order to isolate any effect they may have on the circuitry. The switch symptoms should not change.  | If there is no change in the symptoms, proceed to Step 14.  | If the symptoms change when A8-A15 are lowered, check the logic operation of ICs W, U, Z, A1 and A. If necessary, check the ICs according to the instructions on page 4-5.  |
| 14          | ICs B1 and T on the Display/Control board are not needed for the EXAMINE, EXAMINE NEXT, DEPOSIT and DEPOSIT NEXT functions. If problems occur with these functions, turn power off and remove ICs B1 and T from the board. Removal of B1 and T will isolate any effects these ICs may cause. However, the switch symptoms should not change. | If the symptoms do not change, make sure power is off and reinstall ICs B1 and T. Proceed to Step 15. | If the symptoms change, check pins 1 and 2 of both ICs for LOWs. If absent, trace continuity to the Ground pin of the 7805 voltage regulator on the Display/Control board. Pin 13 of both ICs should be LOW. If not, trace continuity to pin 17 (for IC B1) or 15 (for IC T) of IC A. Repair as necessary. Pin 13 of both ICs should never pulse HIGH for the EXAMINE/EXAMINE NEXT or DEPOSIT/DEPOSIT NEXT functions. Pin 14 of both ICs should be HIGH. If not, trace continuity to Vcc (VR1 pin 2). |
| 15          | Examine the IC outputs in order to test the Display/Control board's open collectors (ICs Y, W and U), the address switches and continuity to pull-up resistors R41-R48 by lifting up each address switch (A8-A15) separately.  | Proceed to Step 16.   | If any of the outputs fail to go HIGH when the corresponding address switch is lifted, check for a LOW input signal. If the input is not LOW, check for shorts and continuity to pin 21 of IC A. A LOW input signal indicates that a bad IC exists or that one of the components is holding the line LOW. Check Vcc and Ground to the IC. Pin 13 of both ICs B1 and T should be LOW. If not, trace continuity back to IC A and check IC   |



| <u>Step</u> | <u>Instructions</u>   | <u>If Correct</u>   | <u>If Incorrect</u>  |
|-------------|---|---------------------|----------------------|
| 16          | <p>A bad open collector can cause the switch data to be examined or deposited improperly. If an address switch is down, the corresponding open collector output is disconnected from Vcc and will float as a LOW. Lifting the address switch should raise the output of the open collector to approximately 4v. (Note: The common inputs of ICs Y, W and U should be LOW when the computer is stopped and no switches are pressed.)</p> <p>A. If the ACCUMULATOR DISPLAY switch will not function, follow the steps below:</p> <p>1) Check the ground strap from VR1 on the Display/Control board to the computer; it must be connected in order for the ACCUMULATOR DISPLAY switch to function properly.</p> | Proceed to Step 2). | Repair as necessary. |

Step

Instructions

If Correct

If Incorrect

- |  |                     |  |
|--|---------------------|--|
| 2) Make sure jumper JD to JC is present on the Interface board.  | Proceed to Step 3). | Repair if necessary.   |
| 3) Check for LOWs at pins 2 and 1 of ICs B1 and T on the Display/Control board. (A constant HIGH should be present at pin 14 of both ICs.)   | Proceed to Step 4). | If pins 2 and 1 are HIGH, trace continuity to Ground (pin 3 of VR1) on the Display/Control board. If pin 14 is LOW, trace continuity to VR1, pin 2. Repair as necessary.   |
| 4) As long as the ACCUMULATOR DISPLAY switch is held, pin 2 of IC G on the Interface board should be LOW. Pins 13 and 14 of IC G should be HIGH and pin 1 should be LOW.   | Proceed to Step 5). | If pin 2 is HIGH, trace logic from IC G to IC Y1 on the Display/Control board. Check any suspected ICs according to the instructions on page 4-5. If pins 13 and 14 of IC G are LOW, trace continuity to VR1 pin 2 (on the Interface board) and repair as necessary. |
| 5) Pressing the ACCUMULATOR DISPLAY switch should produce LOW pulses at pins 8 and 9 of IC D on the Interface board. As a result, pin 10 of IC D should pulse HIGH. Pins 10 and 11 of IC K should also pulse HIGH. | Proceed to Step B.  | Since pulses are usually too rapid to detect visually, run the following program to generate several pulses.   |

| <u>Location</u> | <u>Bit Pattern</u> |
|-----------------|--------------------|
| 000             | 333                |
| 001             | 377                |
| 002             | 303                |
| 003             | 000                |
| 004             | 000                |

StepInstructions

If jumper JE to JF is present on the Interface board, a HIGH pulse should be present at pin 9 of IC K. The resulting LOW at pin 8 (of IC K) should produce a HIGH pulse at pin 11 of IC G.

- B. If the ACCUMULATOR DEPOSIT switch will not function, check the inputs of ICs B1 and T as described in Step 14 on page 4-65.
- C. If the IN switch will not function, check the SENSE switch operation as shown in Table 4-9, starting on page 4-50.
- D. If the OUT switch will not function, check the sense switch operation as shown in Table 4-9, starting on page 4-50.

If CorrectIf Incorrect

(Note: Jumper JE to JF on the Display/Control board must be absent for the following check.) To check the levels of ICs D, J and G pin 4, stop the computer and examine to location 000. Lift the SINGLE STEP switch twice with the above program deposited into memory. If pin 10 of IC K is LOW, trace the SOUT logic to the CPU board. If pin 11 of IC K is LOW, trace the PWR signal to IC M on the CPU board. Check any suspected ICs according to the instructions on page 4-5.

ALTAIR 8800b  
SECTION V  
ASSEMBLY

## SECTION V

### ASSEMBLY

#### 5-1. GENERAL

Section V contains instructions for the circuit and mechanical construction of the Altair 8800b computer. Included in this section are assembly hints, detailed component installation instructions, and printed circuit board and main frame assembly instructions.

#### 5-2. ASSEMBLY HINTS

Before beginning the construction of your unit, it is important that you read the "MITS Kits Assembly Hints" booklet included with your kit. Pay particular attention to the section on soldering, because most problems occur as the result of poor soldering. It is essential that you use the correct type of soldering iron. A 25-30 watt iron with a chisel tip (such as an Ungar 776 with a 7155 tip) is recommended in the assembly hints booklet.

#### NOTE

Some important warnings are also included in the hints booklet. Read them carefully before you begin work on your unit -- failure to heed these warnings could cause you to void your warranty.

Check the contents of your kit against Appendix B (Parts List) in this manual to make sure you have all the required components, hardware, and parts. The components are in plastic envelopes; do not open them until you need the components for an assembly step. You will need the tools called for in the "MITS Kits Assembly Hints" booklet.

As you construct your kit, follow the instructions in the order they are presented in the assembly manual. Always complete each section before going on to the next. Two organizational aids are provided throughout the manual to assist you: 1) Boxed off parts identification lists, with spaces provided to check off the components as they are installed; 2) reproductions of the silkscreens showing previously installed components, components yet to be installed, and components yet to be installed (Figure 5-1).

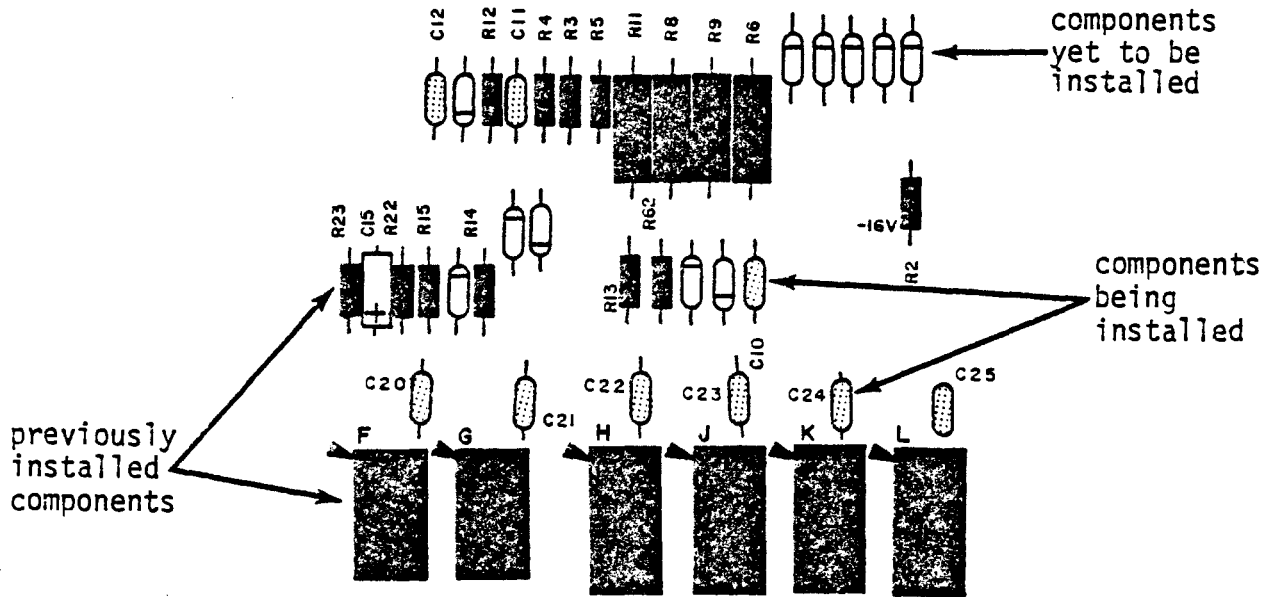

5-1. Typical Silkscreen

## PRINTED CIRCUIT BOARD VISUAL INSPECTION

It is recommended that a visual inspection of the PC Board(s) in your kit be made before beginning the assembly procedures.

Look for etching "bridges" or etching "opens" in the printed circuit lands, as shown in the drawings below:

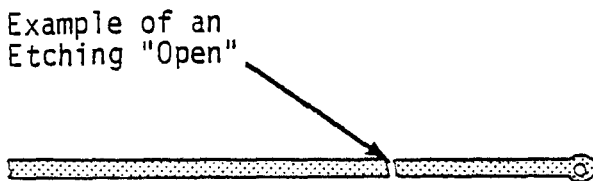
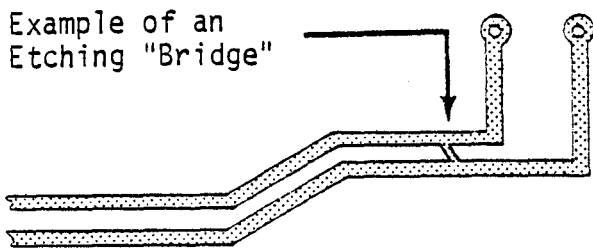

This could also appear as a "hairline" cut.

A thorough visual inspection will eliminate one possibility for errors, should the board not operate properly after it is assembled. Troubleshooting efforts may then be concentrated elsewhere.

## 5-3. COMPONENT INSTALLATION INSTRUCTIONS

Pages 5-6 through 5-12 describe the proper procedures for installing various types of components in your kit.

Read these instructions over very carefully and refer back to them whenever necessary. Failure to properly install components may cause permanent damage to the component or the rest of the unit; it will definitely void your warranty.

More specific instructions, or procedures of a less general nature, will be included within the assembly text itself.

Under no circumstances should you proceed with an assembly step without fully understanding the procedures involved. A little patience at this stage will save a great deal of time and potential "headaches" later.

#### 5-4. Resistor Installation Instructions

Resistors have four (or possibly five) color-coded bands as represented in the chart below. The fourth band is gold or silver and indicates the tolerance. NOTE: In assembling a MITS kit, you need only be concerned with the three bands of color to the one side of the gold or silver (tolerance) band. These three bands denote the resistor's value in ohms. The first two bands correspond to the first two digits of the resistor's value and the third band represents a multiplier.

For example: a resistor with red, violet, yellow and silver bands has a value of 270,000 ohms and a tolerance of 10%. By looking at the chart below, you see that red is 2 and violet 7. By multiplying 27 by the yellow multiplier band (10,000), you find you have a 270,000 ohm (270K) resistor. The silver band denotes the 10% tolerance. Use this process to choose the correct resistor called for in the manual.

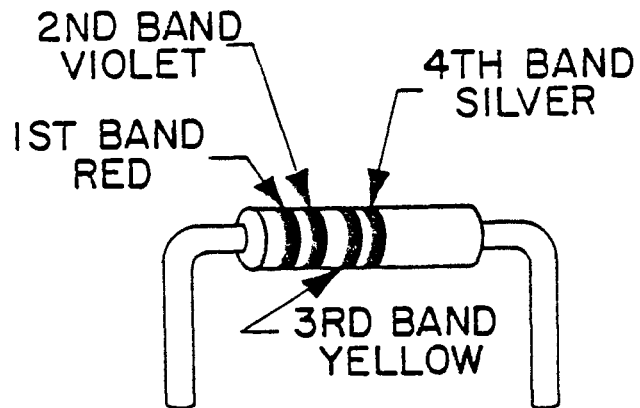

| RESISTOR COLOR CODES |              |                          |
|----------------------|--------------|--------------------------|
| COLOR                | BANDS<br>1&2 | 3rd BAND<br>(Multiplier) |
| Black                | 0            | 1                        |
| Brown                | 1            | 10 <sup>2</sup>          |
| Red                  | 2            | 10 <sup>3</sup>          |
| Orange               | 3            | 10 <sup>4</sup>          |
| Yellow               | 4            | 10 <sup>5</sup>          |
| Green                | 5            | 10 <sup>6</sup>          |
| Blue                 | 6            | 10 <sup>7</sup>          |
| Violet               | 7            | 10 <sup>8</sup>          |
| Gray                 | 8            | 10 <sup>9</sup>          |
| White                | 9            | 10 <sup>9</sup>          |

Use the following procedure to install the resistors onto the boards. Make sure the colored bands on each resistor match the colors called for in the list of Resistor Values and Color Codes given in the assembly instructions.

1. Using needle-nose pliers, bend the leads of the resistor at right angles to match their respective holes on the PC board.
2. Install the resistor into the correct holes on the silk-screened side of the PC board.
3. Holding the resistor in place with one hand, turn the board over and bend the two leads slightly outward.
4. Solder the leads to the foil patte on the back side of the board; then clip off any excess lead lengths.



## 5-5. Capacitor Installation Instructions

### A. Electrolytic Capacitors

Polarity must be noted on electrolytic capacitors before they are installed.

The electrolytic capacitors contained in your kit may have one or possibly two of three types of polarity markings. To determine the correct orientation, look for the following.

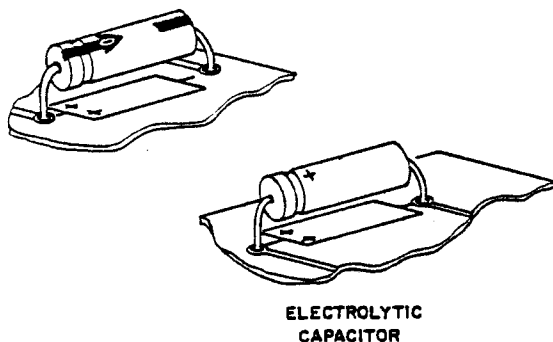

One type will have plus (+) signs on the positive end; another will have a band or a groove around the positive side in addition to the plus signs. The third type will have an arrow on it; in the tip of the arrow there will be a negative (-) sign. The capacitor must be oriented so the arrow points to the negative side.

Install the electrolytic capacitors using the following procedure. Make sure you have the correct capacitor value before installing each one.

1. Bend the two leads of the capacitor at right angles to conform to their respective holes on the board. Insert the capacitor into the holes on the silk-screened side of the board, aligning the positive side with the "+" signs printed on the board.
2. Holding the capacitor in place, turn the board over and bend the two leads slightly outward. Solder the leads to the foil (bottom) side of the board and, clip off any excess lead lengths.

### B. Epoxy Dipped Tantalum, Epoxy Dipped Ceramic, and Ceramic Disk Capacitors

Polarity must be noted on epoxy dipped tantalum capacitors before they are installed.

There are two types of epoxy dipped tantalum capacitors contained in your kit. The first type is blue on the positive side. The second type is marked with "+" signs on the positive side. Both types of epoxy dipped tantalum capacitors are shown in the drawings below.

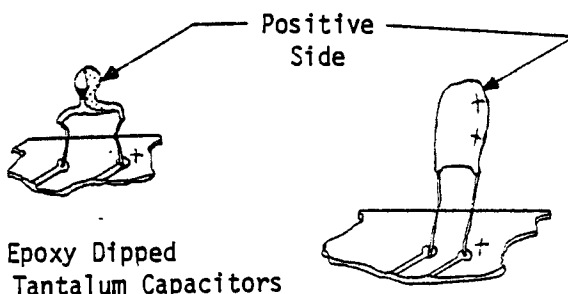

The epoxy dipped ceramic capacitors and the ceramic disk capacitors are non-polarized.

These two types of capacitors are shown in the drawings below.

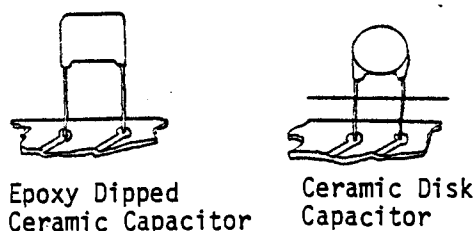

Install these 4 types of capacitors using the following procedure. Make sure you have the correct capacitor value before installing each one.

1. Bend the two capacitor leads to conform to their respective holes on the board.
2. Insert the capacitor into the correct holes from the silk-screened side of the board. Holding the capacitor in place, turn the board over and bend the two leads slightly outward.
3. Solder the two leads to the foil (bottom) side of the board and, clip off any excess lead lengths.

## 5-6. Diode Installation Instructions

NOTE: Diodes are marked with a band on one end indicating the cathode end. Each diode must be installed so that the end with the band is oriented towards the band printed on the PC board. Failure to orient the diodes correctly may result in permanent damage to your unit.

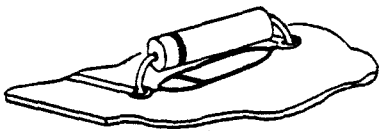

DIODE

Use the following procedure to install diodes onto the board. Refer to the list of Diode Part Numbers included for each board to make sure you install the correct diode each time.

1. Bend the leads of the diode at right angles to match their respective holes on the board.
2. Insert the diode into the correct holes on the silk screen, making sure the cathode end is properly oriented. Turn the board over and bend the leads slightly outward.
3. Solder the two leads to the foil pattern on the back side of the board; then clip off any excess lead lengths.

## 5-7. Transistor Installation Instructions

To install transistors, use the following instructions.

NOTE: Always check the part number of each transistor before you install it. (See listing of Transistor Part Numbers for each board.) Some transistors look identical but differ in electrical characteristics, according to part number. If you have received substitute part numbers for the transistors in your kit, check the Transistor Identification Chart which follows these instructions to be sure you make the correct substitutions.

NOTE: Always make sure the transistor is oriented so that the emitter lead is installed in the hole on the PC board labeled with an "E". To determine which lead is the emitter lead, refer to the Transistor Identification Chart.

1. After the correct transistor has been selected and the leads have been properly oriented, insert the transistor into the holes on the silk-screened side of the board.
2. Holding the transistor in place, turn the board over and bend the three leads slightly outward.
3. Solder the leads to the foil pattern on the back side of the board; then clip off any excess lead lengths.

## TRANSISTOR IDENTIFICATION CHART

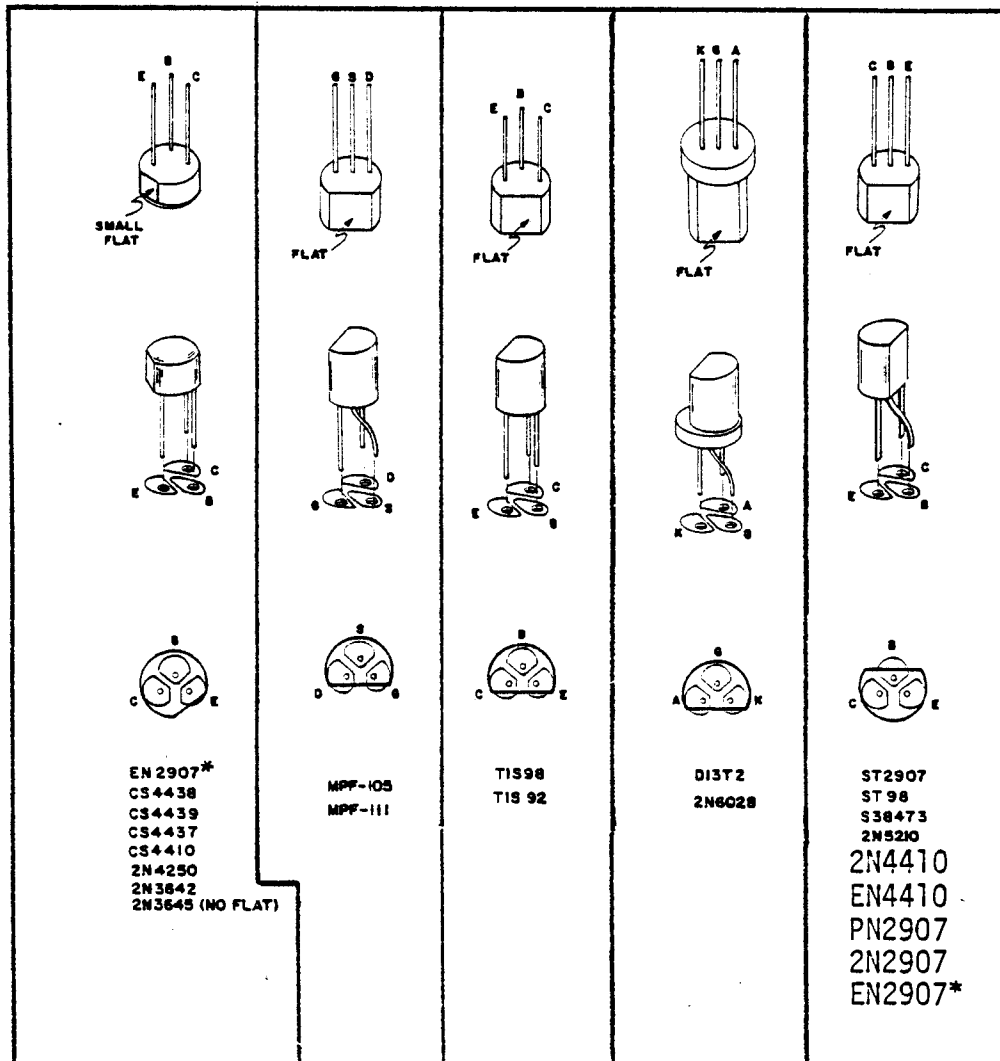

IN THE ILLUSTRATION ABOVE THE OUTLINE OF EACH TYPE OF TRANSISTOR IS SHOWN ABOVE THE PADS ON THE CIRCUIT BOARD WITH THE CORRECT DESIGNATION FOR EACH OF THE THREE LEADS. USE THIS INFORMATION TOGETHER WITH THE INFORMATION IN THE ASSEMBLY MANUAL FOR THE CORRECT ORIENTATION OF THE TRANSISTORS AS YOU INSTALL THEM.

THE FOLLOWING IS A LIST OF POSSIBLE SUBSTITUTIONS: IF ANY OTHERS ARE USED YOU WILL RISK DAMAGING YOUR UNIT:

2N4410 = EN4410 = CS4410 = CS4437, CS4438, TIS98, ST98, S38473 (NPN)  
EN2907 = 2N2907 = PN2907 = ST2907, CS4439 (PNP)

WHEN MAKING SUBSTITUTIONS, REFER TO THE ILLUSTRATION TO DETERMINE THE CORRECT ORIENTATION FOR THE THREE LEADS.

\*Configuration of the leads on EN2907 may vary.

## 5-8. IC Installation Instructions

All ICs must be oriented so that the notched end is toward the end with the arrowhead printed on the PC board. Pin 1 of the IC should correspond with the pad marked with the arrowhead. If the IC does not have a notch on one end, refer to the IC Identification Chart to identify Pin 1.

### To prepare ICs for installation:

All ICs are damaged easily and should be handled carefully -- especially static-sensitive MOS ICs. Always try to hold the IC by the ends, touching the pins as little as possible. When you remove the IC from its holder, CAREFULLY straighten any bent pins using needle-nose pliers. All pins should be evenly spaced and should be aligned in a straight line, perpendicular to the body of the IC itself.

### A. Installing ICs without sockets:

1. Orient the IC so that Pin 1 coincides with the arrowhead on the PC board.
2. Align the pins on one side of the IC so that just the tips are inserted into the proper holes on the board.
3. Lower the other side of the IC into place. If the pins don't go into their holes right away, rock the IC back, exerting a little inward pressure, and try again. Be patient. The tip of a small screwdriver may be used to help guide the pins into place. When the tips of all the pins have been started into their holes, push the IC into the board the rest of the way. Tape the IC to the board with a piece of masking tape.
4. Turn the board over and solder each pin to the foil pattern on the back side of the board. Be sure to solder each pin and be careful not to leave any solder bridges. Remove the masking tape.

#### WARNING:

Make sure none of the pins have been pushed underneath the IC during insertion.

### B. Installing ICs with sockets:

1. Referring to the drawing below, set the IC socket into the designated holes on the board and secure it with a piece of masking tape.

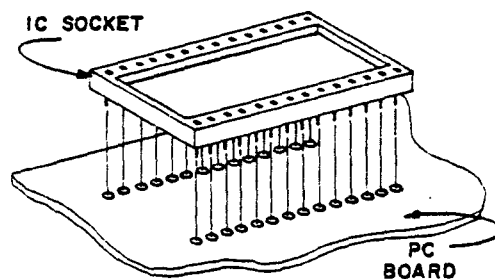

2. Turn the board over and solder each pin to the foil pattern on the back side of the board. Be sure to solder each pin and be careful not to leave any solder bridges. Remove the masking tape.
3. Orient the IC over the socket so that Pin 1 coincides with the arrowhead on the PC board.
4. Align the pins on one side of the socket so that just the tips are inserted into the holes.
5. Lower the other side of the IC into place. If the pins don't go into their holes right away, rock the IC back, exerting a little inward pressure, and try again. Be patient. When the tips of all the pins have been started into their holes, push the IC into the socket the rest of the way.

April, 1977  
8800b

## MOS IC SPECIAL HANDLING PRECAUTIONS

There are several MOS integrated circuits contained in this kit. These IC's are very sensitive to static electricity and transient voltages. In order to prevent damaging these components, read over the following precautions and adhere to them as closely as possible. FAILURE TO DO SO MAY RESULT IN PERMANENT DAMAGE TO THE IC.

- 1) All equipment (soldering iron, tools, solder, etc.) should be at the same potential as the PC board, the assembler, the work surface and the IC itself along with its container. This can be accomplished by continuous physical contact with the work surface, the components, and everything else involved in the operation.
- 2) When handling the IC, develop the habit of first touching the conductive container in which it is stored before touching the IC itself.
- 3) If the IC has to be moved from one container to another, touch both containers before doing so.
- 4) Do not wear clothing which will build up static charges. Preferably wear clothing made of cotton rather than wool or synthetic fibers.
- 5) Always touch the PC board before touching the IC to the board. Try to maintain this contact as much as possible while installing the IC.
- 6) Handle the IC by the edges. Avoid touching the pins themselves as much as possible.
- 7) Dry air moving over plastic can result in the development of a significant static charge. Avoid placing the IC near any such area or object.
- 8) In general, never touch anything to the IC that you have not touched first while touching both it and the IC itself.

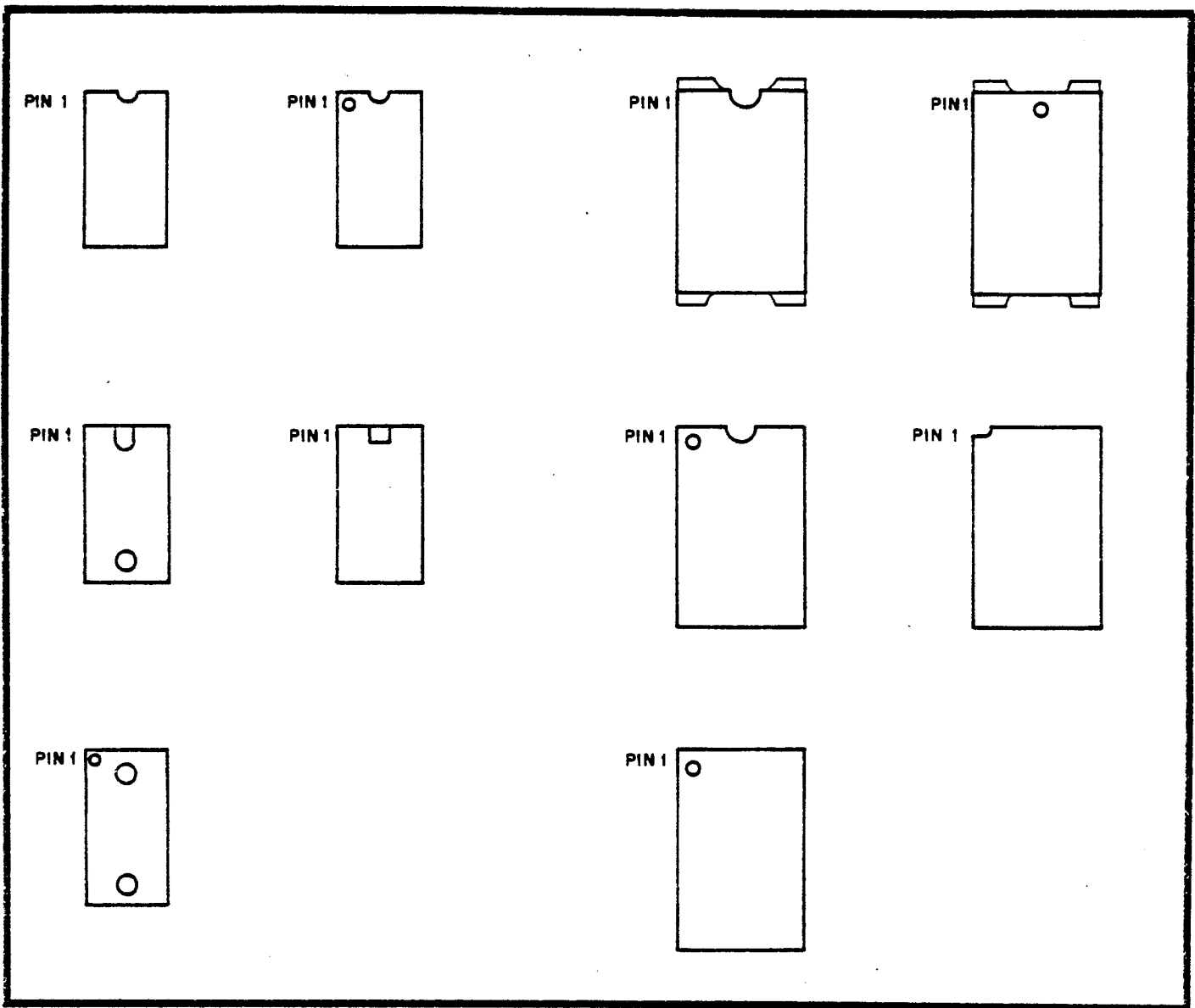

INTEGRATED CIRCUITS (ICs) CAN COME WITH ANY ONE OF, OR A COMBINATION OF, SEVERAL DIFFERENT MARKINGS. THESE MARKINGS ARE VERY IMPORTANT IN DETERMINING THE CORRECT ORIENTATION FOR THE ICs WHEN THEY ARE PLACED ON THE PRINTED CIRCUIT BOARDS. REFER TO THE ABOVE DRAWING TO LOCATE PIN 1 OF THE ICs, THEN USE THIS INFORMATION IN CONJUNCTION WITH THE INFORMATION BELOW TO PROPERLY ORIENT EACH IC FOR INSTALLATION.

**WARNING: INCORRECTLY ORIENTED IC'S MAY CAUSE PERMANENT DAMAGE!**

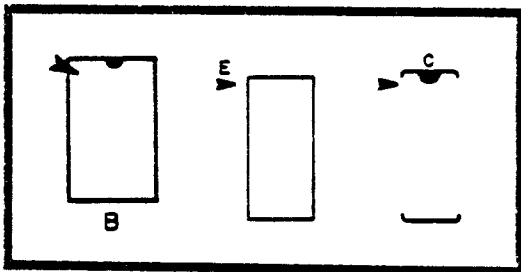

THE DRAWING ON THE LEFT INDICATES VARIOUS METHODS USED TO SHOW THE POSITION OF ICs ON THE PRINTED CIRCUIT BOARDS. THESE ARE SILK-SCREENED DIRECTLY ON THE BOARD. THE ARROWHEAD INDICATES THE POSITION FOR PIN 1 WHEN THE IC IS INSTALLED.

## 5-9. INTERFACE CARD ASSEMBLY

### 5-10. IC INSTALLATION (Figure 5-2)

Install the following 22 integrated circuits (Bag 1) on the Interface Card according to the IC Installation Instructions, Section A, given on page 5-10. IC G will be installed with a 24-pin socket according to the IC Installation Instructions, Section B, page 5-10.

The chart below lists the 22 ICs, their corresponding part numbers, and acceptable part substitutions.

| IC Part Numbers              |                       |
|------------------------------|-----------------------|
| ( ) C,E,M,P,R,T<br>U,V,W,X,Y | 74LS04 or 74LS14      |
| ( ) A,B,L                    | 74LS20 or 74LS13      |
| ( ) F,H,N,S                  | 74367 or 8097 or 8T97 |
| ( ) J                        | 7400 or 74LS00        |
| ( ) D                        | 7402 or 74LS02        |
| ( ) K                        | 7410 or 74LS10        |
| ( ) G (with socket)          | 8212                  |

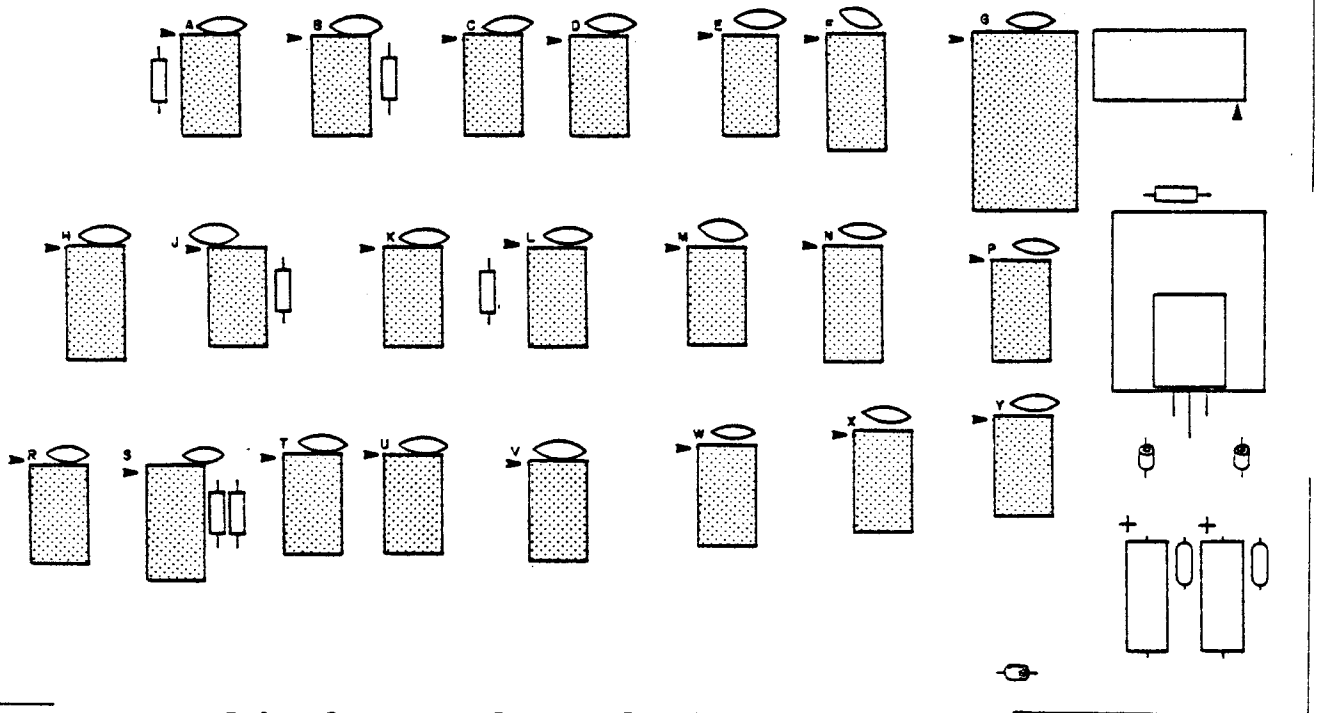

5-2. Interface IC Installation

5-11. RESISTOR INSTALLATION (Figure 5-3)

Install the 7 resistors, R1 through R7 (Bag 5), on the Interface Card according to the Resistor Installation Instructions given on page 5-6.

| Resistor Values   |                                       |
|-------------------|---------------------------------------|
| ( ) R1 through R7 | 2.2K ohm (red, red, red) 1/2W or 1/4W |

**NOTE**  
Save the excess resistor leads for use in Paragraph 5-15.

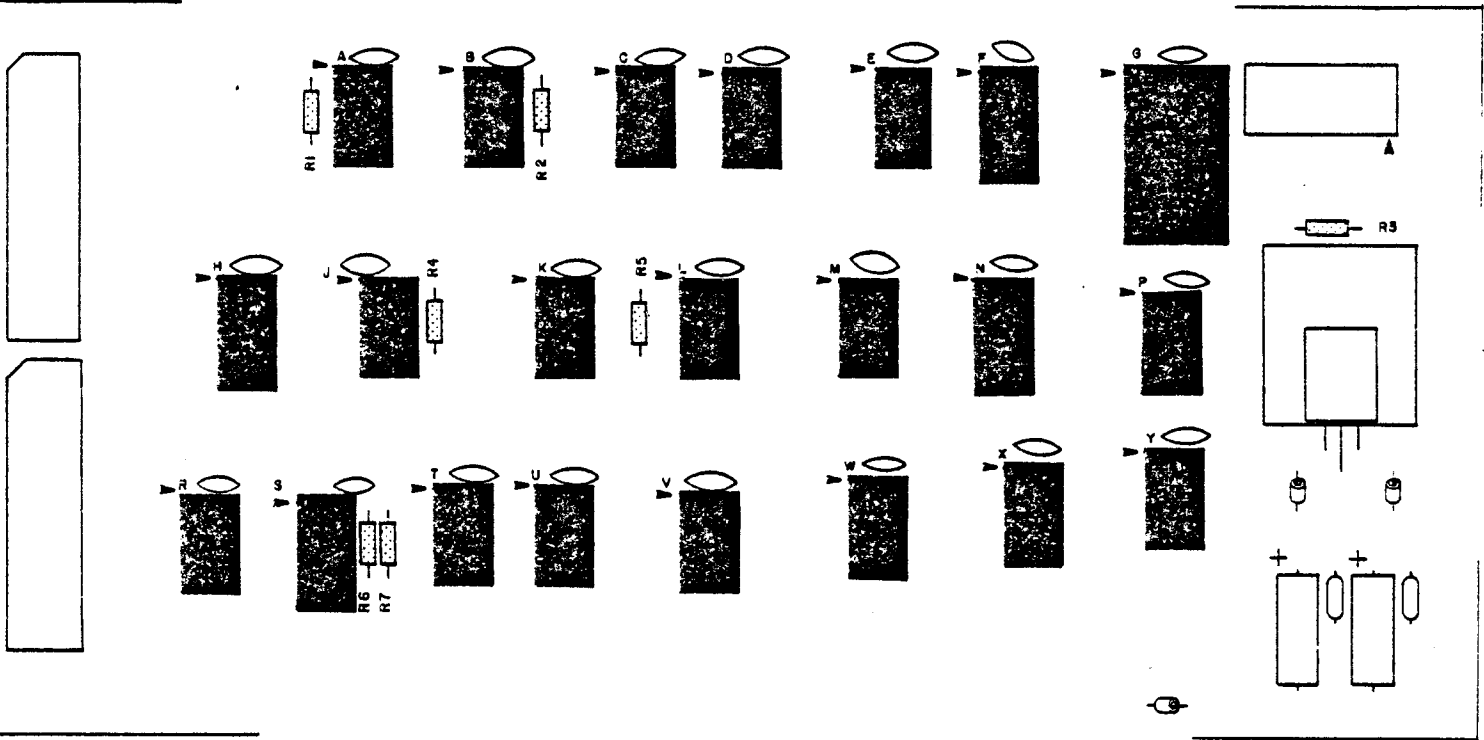

5-3. Interface Resistor Installation



5-12. SUPPRESSOR CAPACITOR INSTALLATION (Figure 5-4)

There are 22 suppressor capacitors (Bag 2) to be installed on the Interface Card. These capacitors are used for noise suppression. They are located next to the ICs on the silkscreen, but they have no individual component designations. Install the suppressor capacitors according to the Ceramic Disk Capacitor Installation Instructions given on page 5-7.

| Suppressor Capacitor Values  |                          |
|------------------------------|--------------------------|
| ( ) 22 suppressor capacitors | 0.1uf, 12V or 0.1uf, 16V |

**NOTE**

Save the clipped off capacitor leads for use as jumper wires in Paragraph 5-14.

5-13. CAPACITOR INSTALLATION (Figure 5-4)

Install the two electrolytic capacitors, C1 and C3 (Bag 2), and the two ceramic disk capacitors, C2 and C4 (Bag 2), according to the instructions given on page 5-7.

The chart below lists the 4 capacitors and their values.

| Capacitor Values |  |
|------------------|--|
| ( ) C1, C3*      | 20uf - 35uf, 12V - 20V, electrolytic   |
| ( ) C2, C4       | 0.1uf, 12V or 0.1uf, 16V, ceramic disk |

\*C1 and C3 may have any value within the range shown.

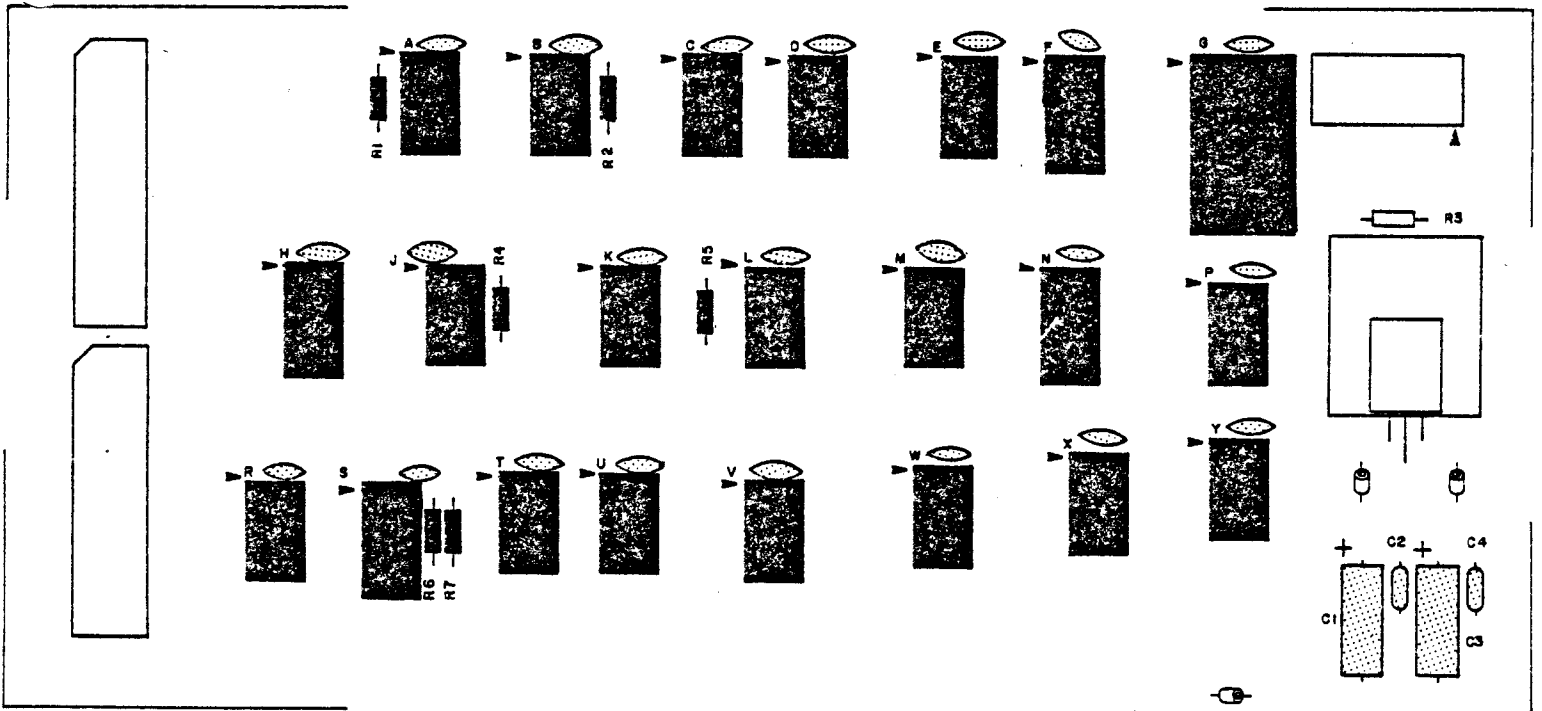

5-4. Interface Suppressor Capacitor and Capacitor Installation

5-14. JUMPER CONNECTIONS (Figure 5-5)

There are two jumper wires to be installed on the Interface Card. Use the capacitor leads saved from the Suppressor Capacitor Installation. Cut two leads, to 1-inch lengths, and jumper the following pads on the Interface Card.

Jumper Connections

( ) JC to JD

( ) JE to JF

NOTE

Do not jumper JA to JB here.

5-15. FERRITE BEAD INSTALLATION (Figure 5-6)

Install the three ferrite beads, L1 through L3 (Bag 3), according to the following instructions.

1. Using the resistor leads saved from Paragraph 5-11, cut three 1-inch lead lengths.
2. Insert a lead through the bead, and bend the ends so they conform to their designated holes on the Interface Card.
3. Insert the leads into the card, and solder to the foil (bottom) side of the card. Be sure not to leave any solder bridges and clip off any excess lead lengths.

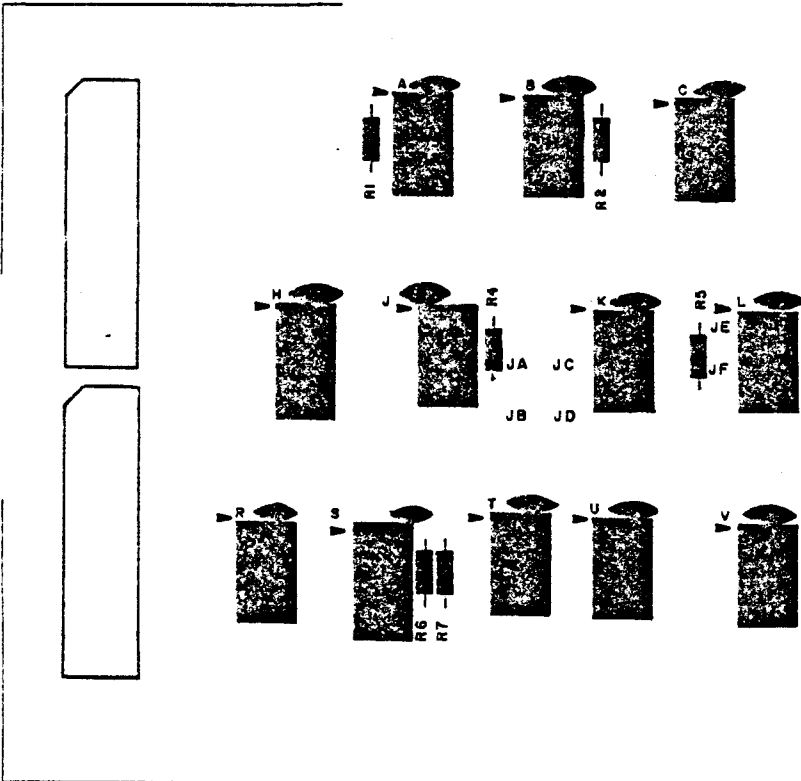

5-5. Interface Jumper Connections

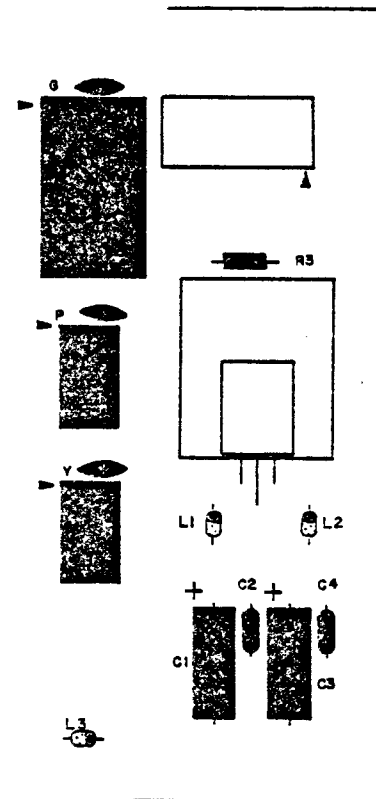

5-6. Interface Ferrite Bead Installation

# INSERT PAGE

Altair 8800b

## Interface Card Assembly Procedure

Addendum to page 5-16, Jumper Connections

If the D/C Interface Board jumpers are installed according to the instructions given on page 5-16, the front panel data lights will display outputs to channel 377<sub>8</sub> (255<sub>10</sub>). If jumper JE-JF is removed, the data lights will display outputs to all channels. For a more detailed discussion of these jumper options, refer to the Theory of Operation Manual, page 3-60, and Figure 3-15 (sheet 3).

5-16. VOLTAGE REGULATOR INSTALLATION  
(Figure 5-7)

Install the voltage regulator, VR1 (Bag 1), and heat sink on the Interface Card according to the following instructions.

1. Set the regulator in place on the silk-screened side of the Interface Card, aligning the leads with their designated holes.
2. Use needle-nose pliers to bend each of the three leads at a right angle to conform to its proper hole on the card.

3. Referring to Figure 5-7, set the regulator and heat sink in place on the silk-screened side of the card. Secure them in place with a #6-32 x 3/8 inch screw, a #6 lockwasher, and a #6-32 nut.
4. Solder the three leads to the foil (bottom) side of the card. Be sure not to leave any solder bridges.
5. Clip off any excess lead lengths.

|                               |      |
|-------------------------------|------|
| Voltage Regulator Part Number |      |
| ( ) VR1                       | 7805 |

**NOTE**

Use heat sink grease when installing this component. Apply the grease to all metal surfaces which come in contact with each other.

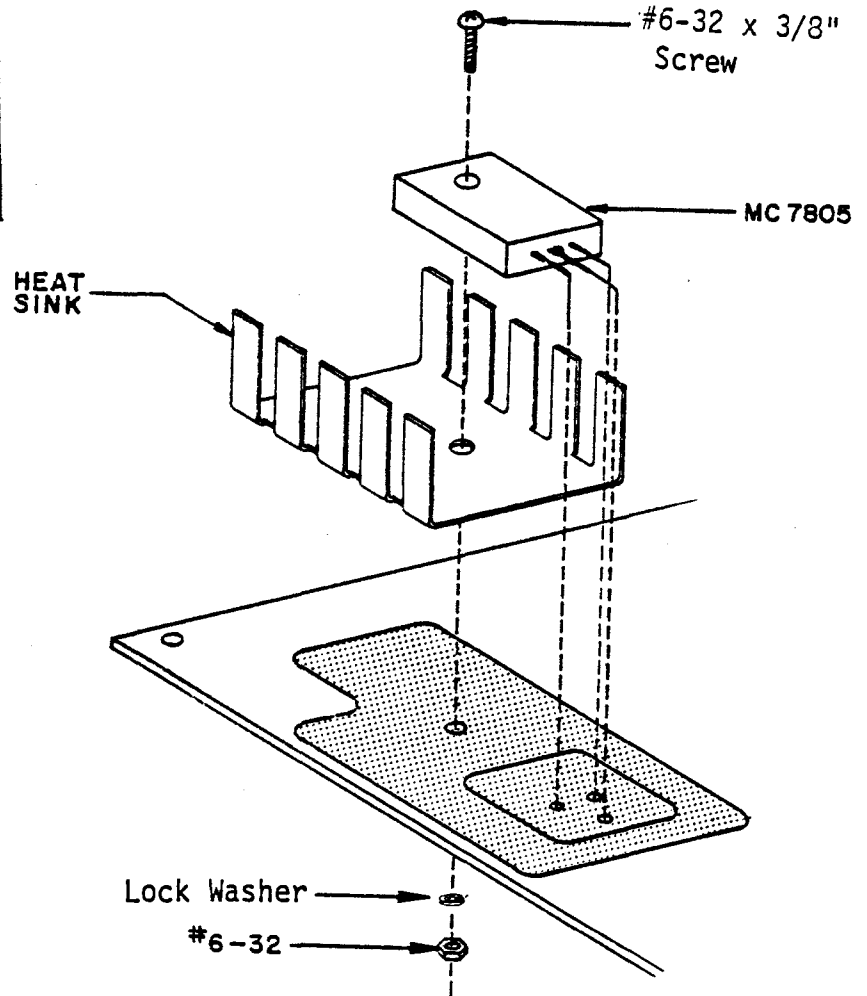
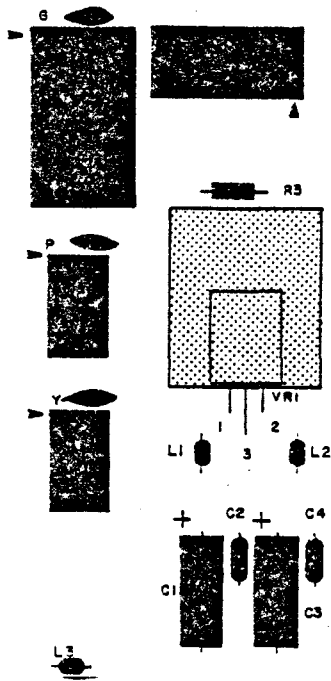

5-7. Interface Voltage Regulator Installation

5-17. MALE CONNECTOR INSTALLATION  
(Figure 5-8)

Install one 10-pin Male Connector, P3 (Bag 3), on the Interface Card according to the following instructions.

1. Orient the connector as shown in Figure 5-8, with the bent pins pointing towards the top of the card.
2. Insert the short pins into the 10 designated holes on the silk-screened side of the card.

3. Solder each pin to the foil (bottom) side of the card. Be sure not to leave any solder bridges.
4. Clip off any excess lead lengths.

5. The arrow on the silkscreen points to Pin #1. After installing the male connector, clip off pin #2 of the connector. This is done for keying purposes. Further keying instructions are given in Paragraph 5-76.

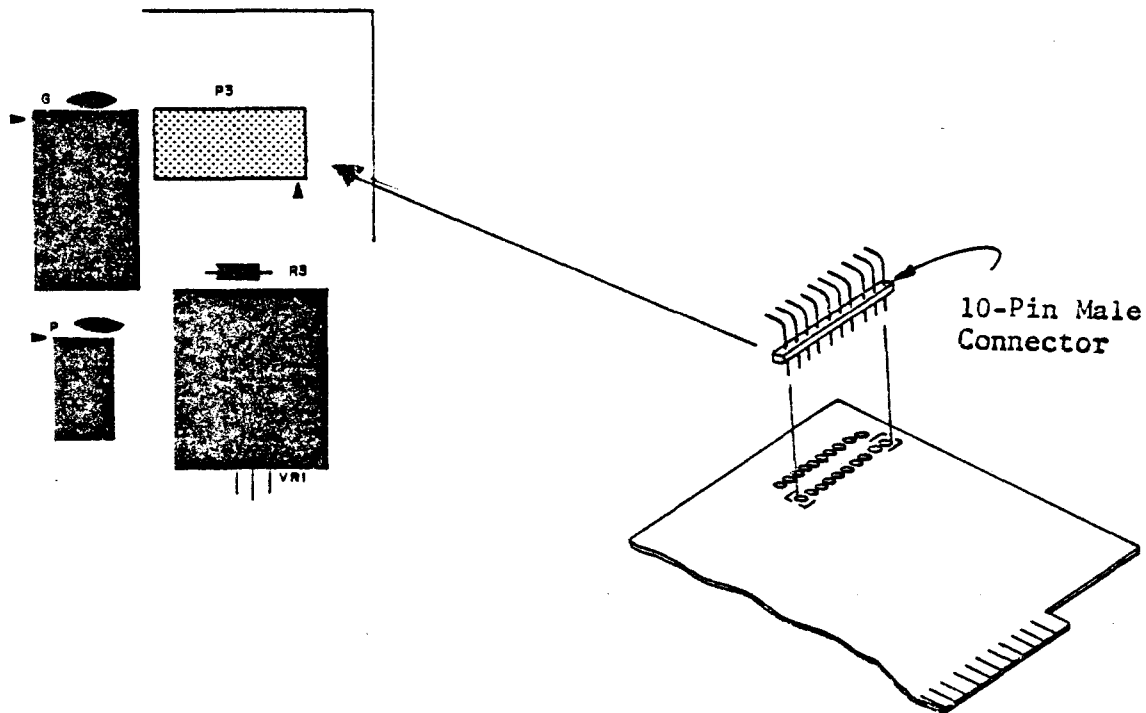

5-8. Interface Male Connector Installation

5-18. RIBBON CABLE PLUG INSTALLATION (FIGURE 5-9)

Install the two ribbon cable plugs, P1 and P2 (Bag 4), on the Interface Card according to the following instructions.

1. Orient the Ribbon Cable Plug as shown in Figure 5-9, so that the socket end of the plug hangs over the left side of the card.

2. Insert the pins into their proper holes and solder each pin to the foil (bottom) side of the card. Be sure not to leave any solder bridges.

NOTE

The socket end of the Ribbon Cable Plug will be connected later in Paragraph 5-75.

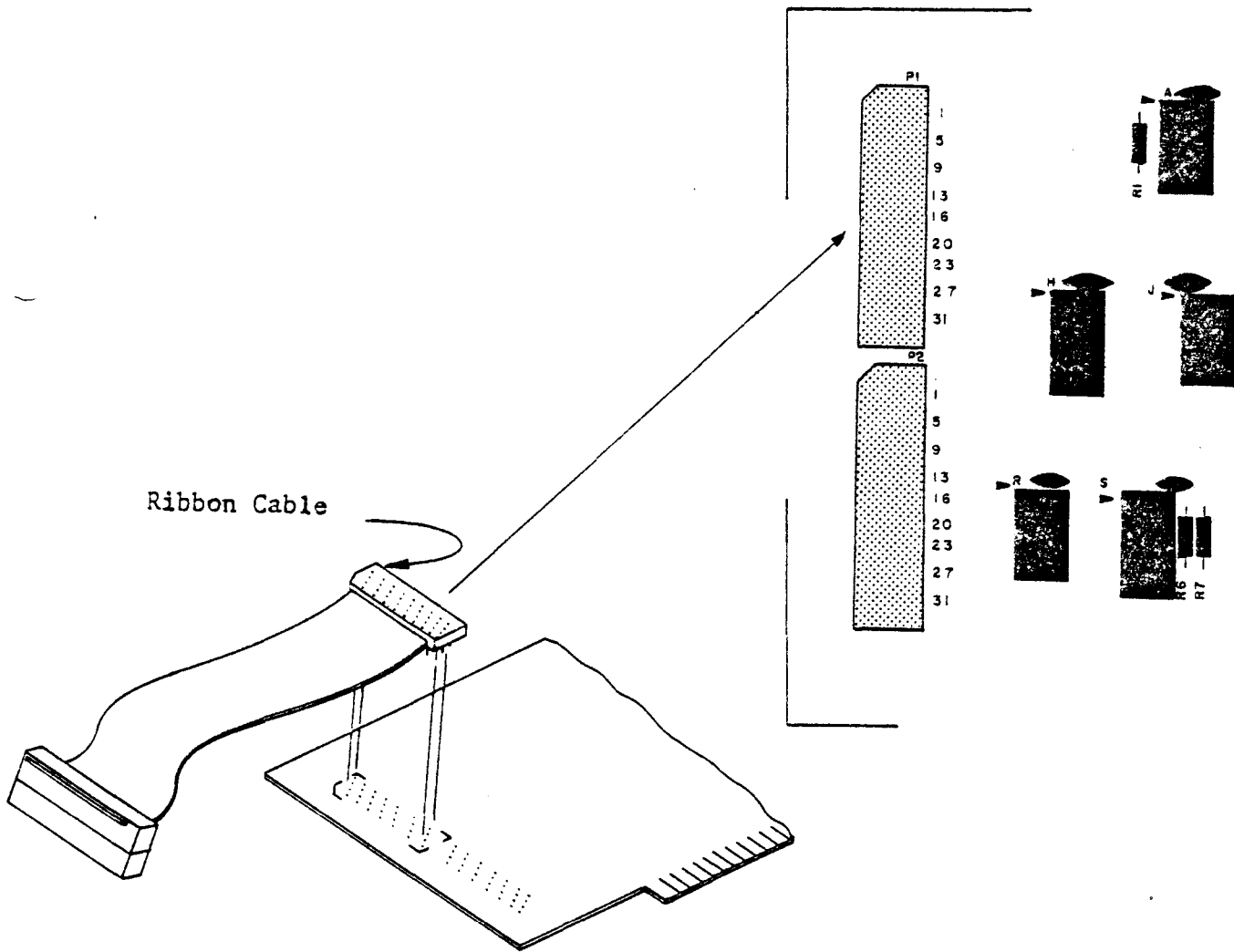

5-9. Interface Ribbon Cable Plug Installation

5-19. DISPLAY/CONTROL BOARD ASSEMBLY

5-20. IC SOCKET AND IC INSTALLATION  
(Figure 5-10)

There are 4 ICs, A, G, T, B1 (Bag10), to be installed with sockets on the Display/Control Board. Install these sockets and ICs according to the Integrated Circuit Installation Instructions, Section B, given on page 5-10.

| Silkscreen Designation                          | IC Part Number | Socket Size |
|---|----------------|-------------|
| ( ) A, T, B1                                    | 8212           | 24-pin      |
| ( ) G   | 1702A*         | 24-pin      |
| *IC G is a programmed PROM IC labelled "B D/C". |                |             |

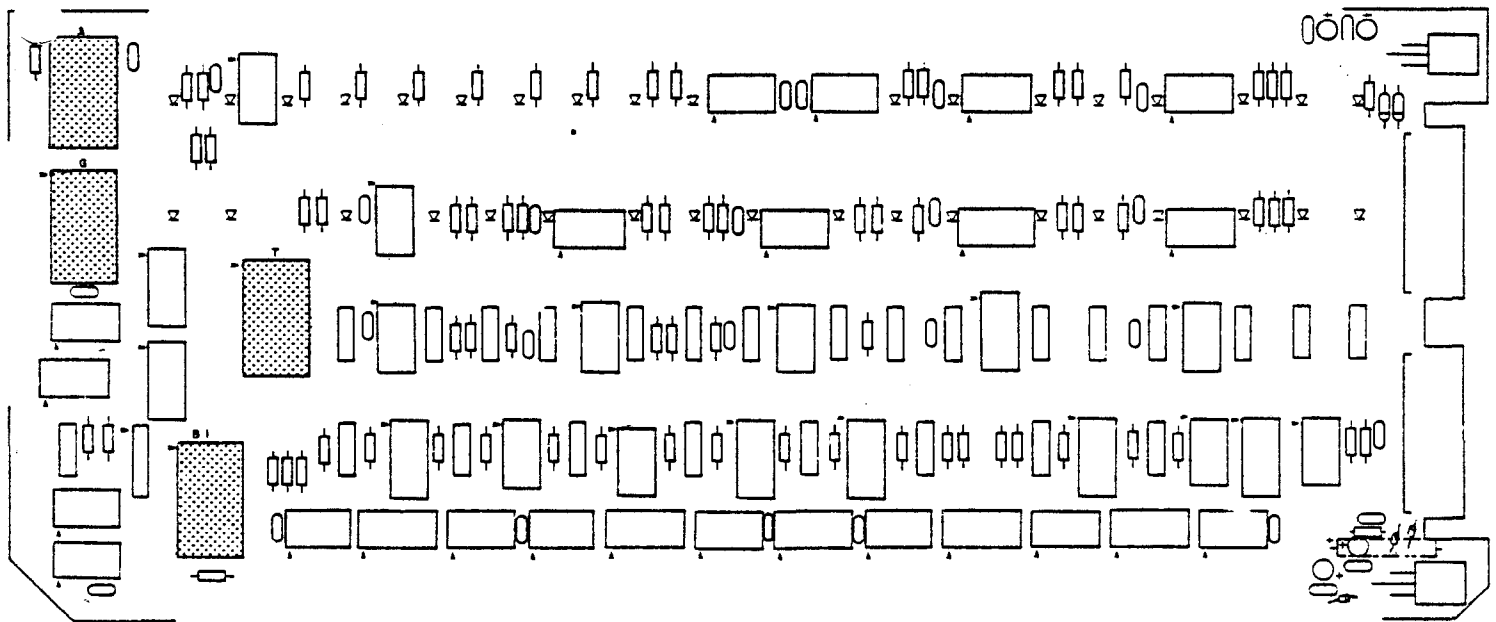

5-10. Display/Control IC Socket and IC Installation

5-21. IC INSTALLATION (Figure 5-11)

Install the following 42 integrated circuits (Bag 1) on the Display/Control Board according to the Integrated Circuit Installation Instructions, Section A, given on page 5-10.

| IC Part Numbers                 |                          |
|---------------------------------|--------------------------|
| ( ) B,D,E,F,H,K,M               | 7407                     |
| ( ) U,W,Y,V1,Z1                 | 7405 or 74LS05           |
| ( ) C1,N1,F1,U1,<br>G1,W1,H1,Y1 | 74LS175                  |
| ( ) L1,M1                       | 74LS74                   |
| ( ) K1                          | 74367 or 8097<br>or 8T97 |
| ( ) R,S                         | 8T98                     |
| ( ) P                           | 7493                     |
| ( ) P1,Z                        | 7400 or 74LS00           |
| ( ) C,J1,E1,R1                  | 74LS04                   |
| ( ) A1                          | 74LS14                   |
| ( ) J                           | 74L10                    |
| ( ) V,D1,T1                     | 7410 or 74LS10           |
| ( ) X1,N                        | 74LS30 or 74L30          |
| ( ) L,X                         | 4040                     |
| ( ) S1                          | 4009, 4049<br>or 4449    |

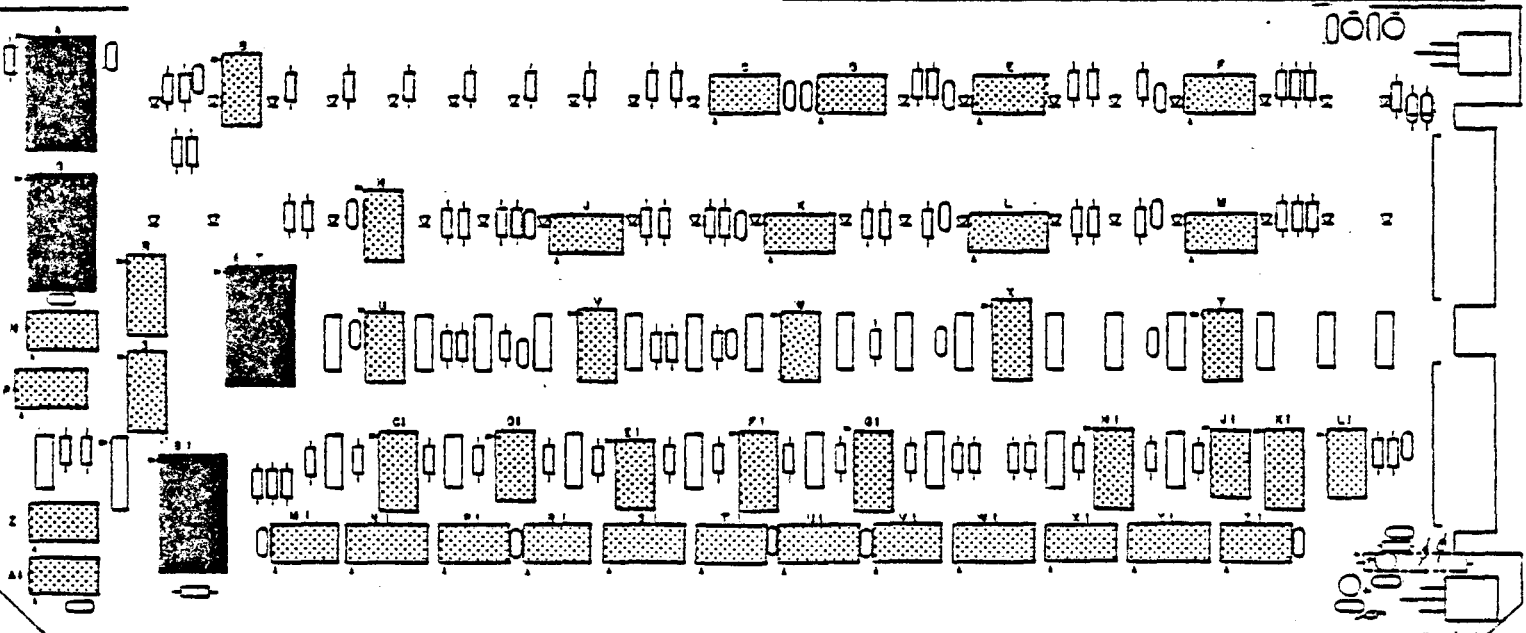

5-11. Display/Control IC Installation



5-22. RESISTOR INSTALLATION  
 (Figure 5-12, page 5-24)

There are 76 resistors (Bags 2, 3 and 4) to be installed on the Display/Control Board. Install these resistors according to the Resistor Installation Instructions given on page 5-6.

NOTE

Save any excess resistor leads for jumper connections in Paragraph 5-24 and for ferrite bead installation in Paragraph 5-28.

Do NOT install R76 at this time.  
It will be installed on the back of the board when the Voltage Regulator installation (page 5-30) has been completed.

| Resistor Values                                       |   |
|---|---|
| ( ) R2-R19, R21, R22, R24-R26, R28-R30, R32-R41, R73  | 220 ohm (red, red, brown) 1/2W                      |
| ( ) R50, R75  | 100 ohm (brown, black, brown) 1/2W                  |
| ( ) R66   | 470 ohm (yellow, violet, brown) 1/2W                |
| ( ) R20   | 1K ohm (brown, black, red) 1/2W                     |
| ( ) R1, R23, R27, R31, R42-R49, R51-R65, R67-R72, R74 | 2.2K ohm (red, red, red) 1/2W                       |
| ( ) R76   | 5 ohm (wire wound resistor; has no color codes) 5W* |

\* Due to supply variations, the 5 ohm, 5 watt resistor supplied with your kit will be one of three sizes:

- a) Diameter = .22", length = .7"
- b) Diameter = .17", length = .9"
- c) Diameter = .3", length = .9"

Size "A" and size "B" resistors should be installed on the back of the board in the position shown on the silkscreen. Size "C" resistors should also be installed on the back of the board, however, the resistor leads must be left long enough so that the resistor will fit underneath the mother board. The resistor can be positioned correctly by holding the Display/Control Board vertically against a table top and bending the resistor down until it is flush against both the board and the table top. Be sure to insulate the resistor leads with tubing so that there are no bare leads exposed. Be especially careful to see that the resistor lead cannot short to the mounting screw of the 5 volt regulator.

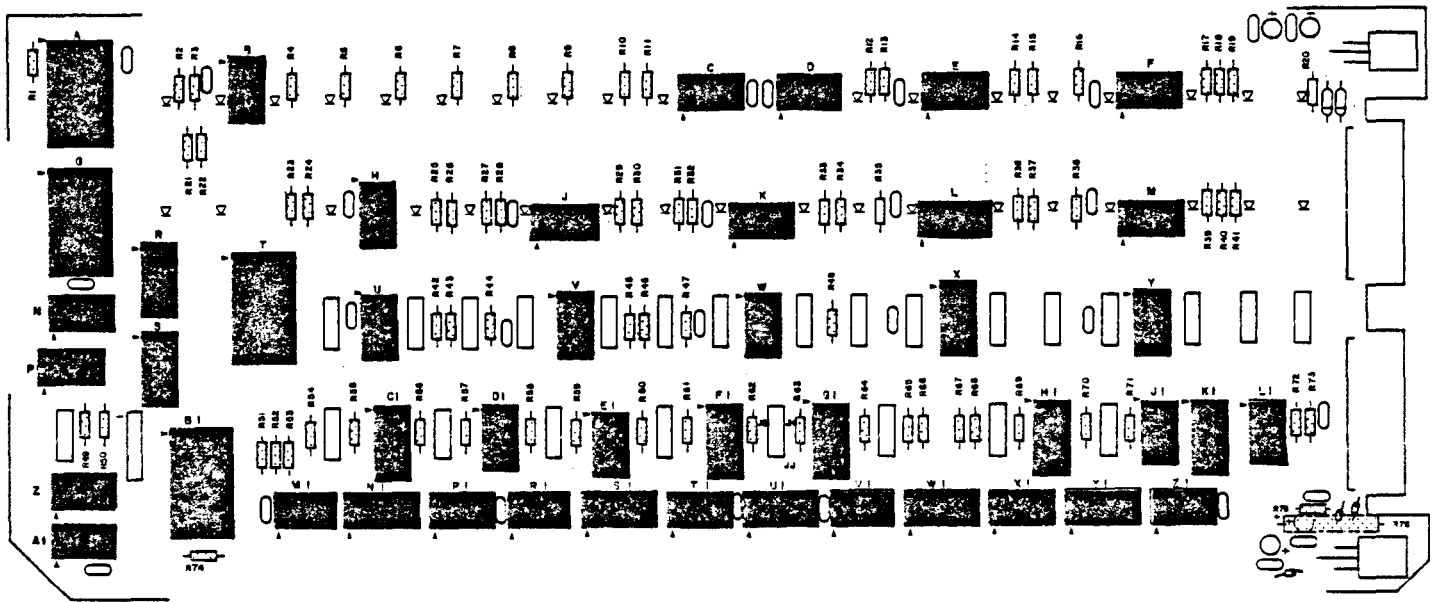

5-12. Display/Control Resistor Installation

5-23. RESISTOR PACK INSTALLATION  
(Figures 5-13 and 5-14)

According to supply variations, your kit will contain either one resistor pack, RP1 (Bag 2), or 5 individual 4.7K-ohm resistors to be substituted for RP1.

NOTE

It is necessary to clip off the last three leads on the resistor pack at the end furthest from the small dot. There are no holes on the PC board for these leads, and these three resistors are not used.

A. Resistor Pack (Figure 5-13). Use the following instructions to install the resistor pack as shown in Figure 5-13.

| Resistor Pack | Value     |
|---------------|-----------|
| ( ) RP1       | 4.7K ohms |

1. The resistor pack has a small dot printed at one end. This dot must correspond with the dot printed on the PC Board. Insert the resistor pack perpendicular to the silk-screened side of the board, aligning the small dots.

2. Solder each pin of the resistor pack to the foil (bottom) side of the board. Be careful not to leave any solder bridges.

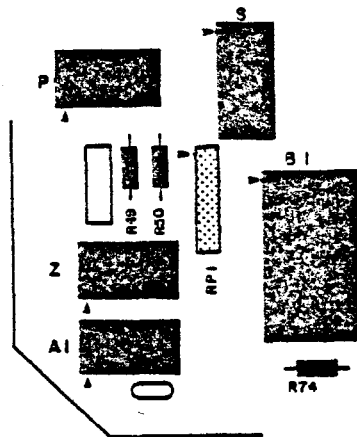

5-13. Display/Control Resistor Pack Installation

- B. Substitute Resistors (Figure 5-14). If your kit is not supplied with a resistor pack, use the following instructions to install the 5 substitute resistors.

1. The resistor pack designation on the silkscreen has 5 holes. The left-most hole is marked on the silkscreen with a small dot. Vertically insert one resistor into the right-most hole on the board. Bend the top lead at a right angle as shown in Figure 5-14A until it is parallel with the board. Then bend the end of the lead at a right angle so that it may be inserted into the left-most hole marked with a small dot.
2. Solder the two inserted leads to the foil (bottom) side of the board.
3. Insert the remaining four resistors vertically into the designated holes on the silkscreen. Solder each of the top leads to the common horizontal lead as shown in Figure 5-14A. It may be helpful to bend the top leads against the horizontal lead for better contact before soldering.
4. Solder the inserted leads of the four resistors to the foil (bottom) side of the board. Clip off all excess leads from the top and bottom of the resistors. The properly completed resistor assembly is shown in Figure 5-14B.

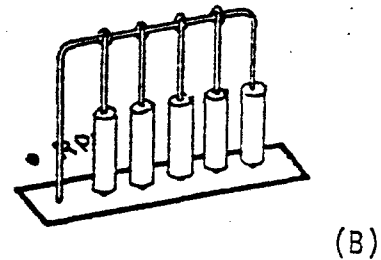
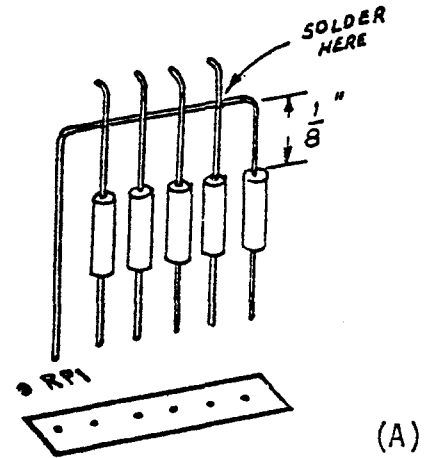

5-14. Display/Control Substitute Resistor Assembly



5-25. SUPPRESSOR CAPACITOR INSTALLATION (Figure 5-16)

Install all 22 suppressor capacitors according to the Ceramic Disk Capacitor Installation Instructions given on page 5-7.

There are 22 suppressor capacitors (Bag 6) to be installed on the Display/Control Board. These capacitors are used for noise suppression. They are located next to the ICs on the silkscreen, but they have no individual component designations.

| Suppressor Capacitors        | Value     |
|------------------------------|-----------|
| ( ) 22 suppressor capacitors | .1uf, 12V |

Note that there is not enough space between P1 and R1; T1 and U1; and U1 and V1 for the suppressor capacitors to fit on the top of the board. These three capacitors will, therefore, be installed on the back of the board.

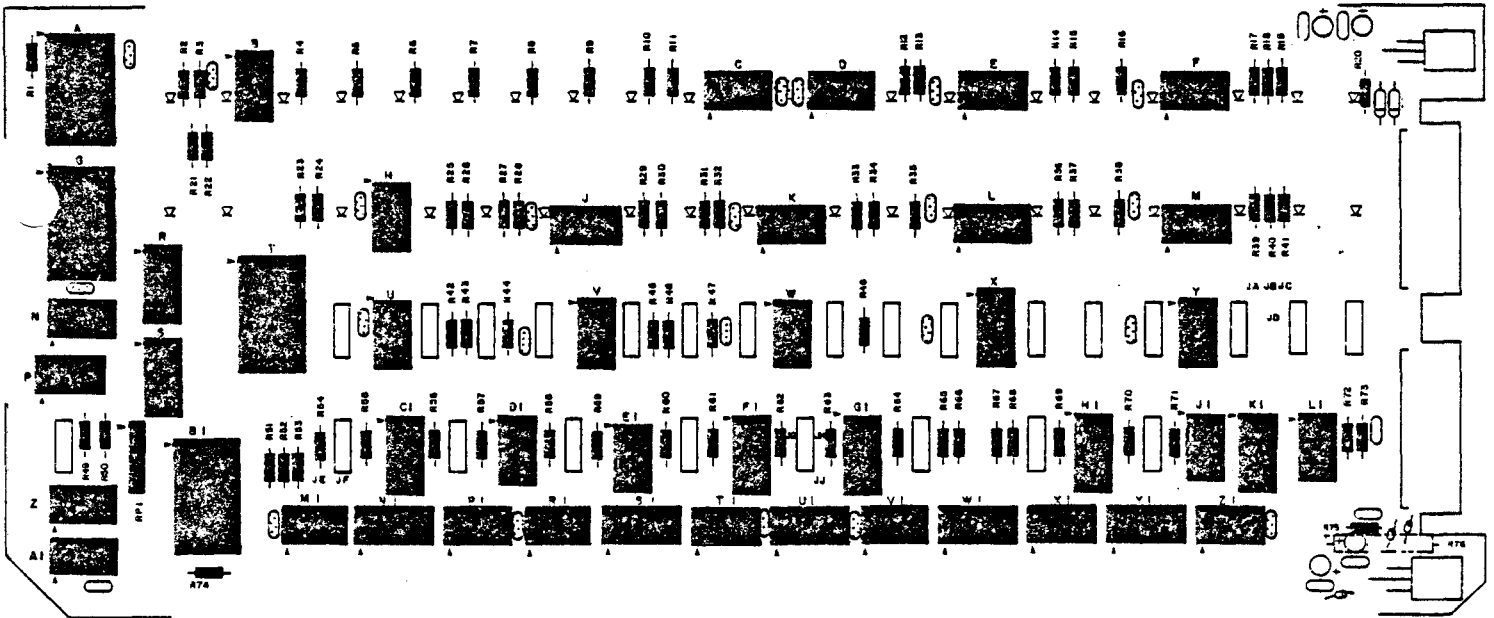

5-16. Display/Control Suppressor Capacitor Installation

5-26. CAPACITOR INSTALLATION  
(Figure 5-17)

There are two types of capacitors to be installed on the Display/Control Board. C2, C4, C8, and C9 (Bag 5) are dipped tantalum capacitors. They are marked with a plus sign on the positive side. Be sure to orient this plus sign with the plus sign on the silkscreen before installing each dipped tantalum capacitor. C1, C3, C5, C6, C10, and C11 (Bag 6) are ceramic disk capacitors. They need no polarity orientation. Install the dipped tantalum capacitors according to the Epoxy Dipped Tantalum and Ceramic Disk Capacitor Installation Instructions given on page 5-7.

| Capacitor Values |                            |
|------------------|----------------------------|
| ( ) C2, C4       | 22uf, 35V, dipped tantalum |
| ( ) C8, C9       | 47uf, 16V, dipped tantalum |
| ( ) C1, C10, C11 | .1uf, 12V or .1uf, 16V     |
| ( ) C3           | .1uf, 50V (SK .1m)         |
| ( ) C5, C6,      | .001uf                     |

**NOTE**  
There is one .001  $\mu$ f capacitor (C7) included with your kit that is not needed. Capacitor C7 should not be installed.

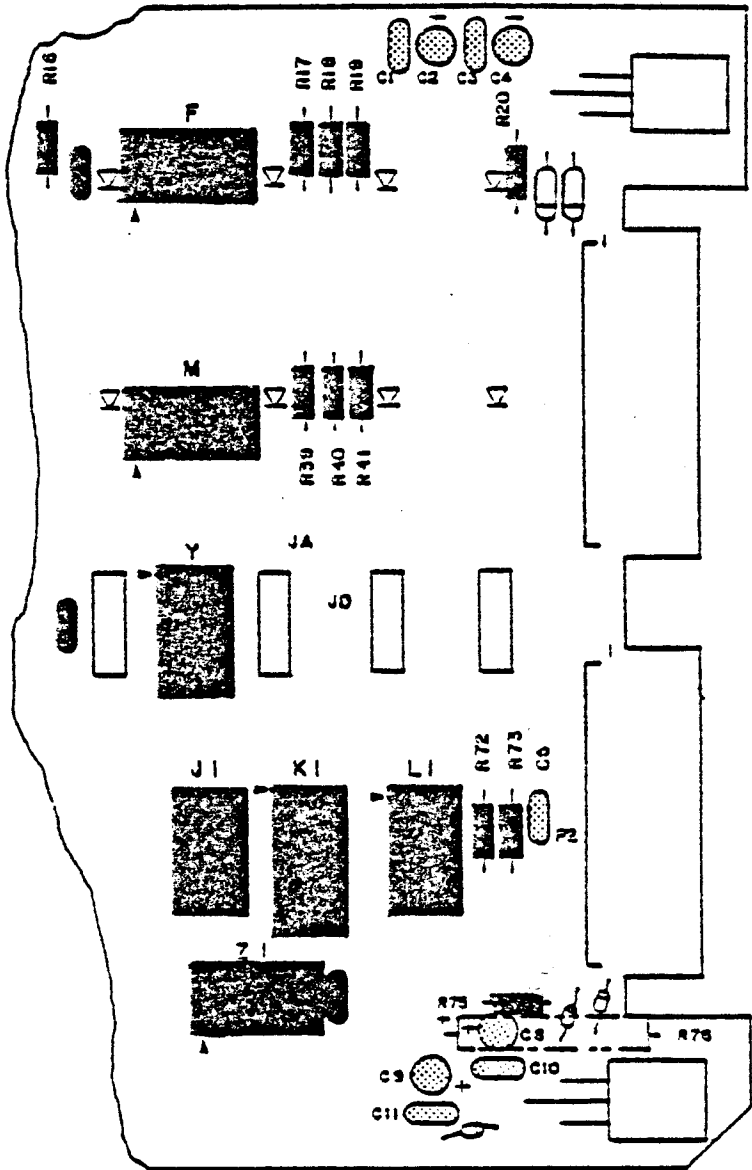
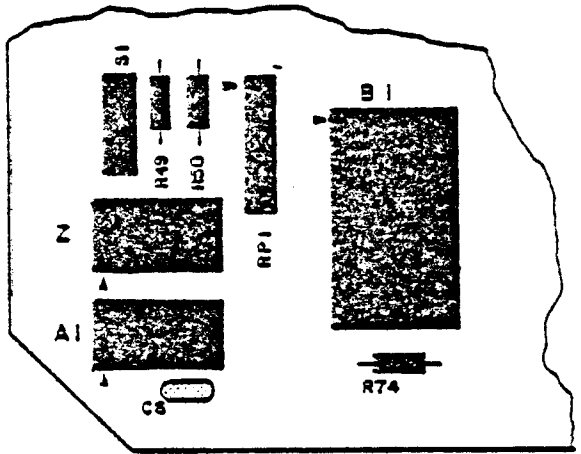

5-17. Display/Control Capacitor Installation

5-27. DIODE INSTALLATION (Figure 5-18)

Install the 2 diodes, D1 and D2 (Bag 2), on the Display/Control Board according to the Diode Installation Instructions given on page 5-8.

| Diode      | Part Number |
|------------|-------------|
| ( ) D1, D2 | IN914       |

5-28. FERRITE BEAD INSTALLATION (Figure 5-18)

Install the three ferrite beads, L1 through L3 (Bag 2), on the Display/Control Board according to the following instructions.

1. Using the resistor leads saved from Paragraph 5-22, cut three 1-inch lead lengths.
2. Insert the lead through the bead and bend the ends of the lead to conform to the designated holes on the Display/Control Board.
3. Insert the lead into the proper holes from the silk-screened side of the board, and solder to the foil (bottom) side of the board. Be sure not to leave any solder bridges.
4. Clip off any excess lead lengths.

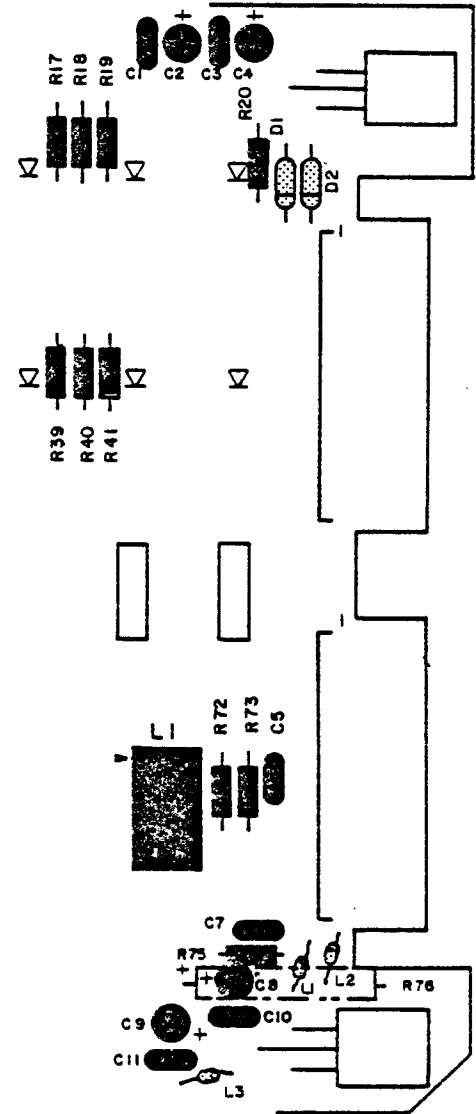

5-18. Display/Control Diode and Ferrite Bead Installation

5-29. VOLTAGE REGULATOR INSTALLATION (Figure 5-19)

Install the two voltage regulators, VR1 and VR2 (Bag 1), on the Display/Control Board according to the following instructions.

| Voltage Regulator | Part Number |
|-------------------|-------------|
| ( ) VR1           | 79M08       |
| ( ) VR2           | 7805        |

1. Set the regulator in place on the silk-screened side of the board, aligning the leads with their designated holes.
2. Use needle-nose pliers to bend each of the three leads at a right angle to conform to its proper hole on the board.
3. Prepare a 3" ground strap according to the instructions given in Paragraph 5-72, page 5-71. Secure VR1 in place on the silk-screened side of the board with a #6-32 x 1/4" screw, a #6 lockwasher and a #6-32 nut. Secure VR2 on the silkscreened side of the board and the ground strap on the back of the board with a #6-32 x 1/4" screw and a #6-32 nut. Orient the strap horizontally so that it is pointing away from the board.
4. Solder the three leads to the foil (bottom) side of the board. Be sure not to leave any solder bridges.
5. Clip off any excess lead lengths.

**NOTE**

Refer to the silkscreen on page 5-24 and install R76 on the back of the board.

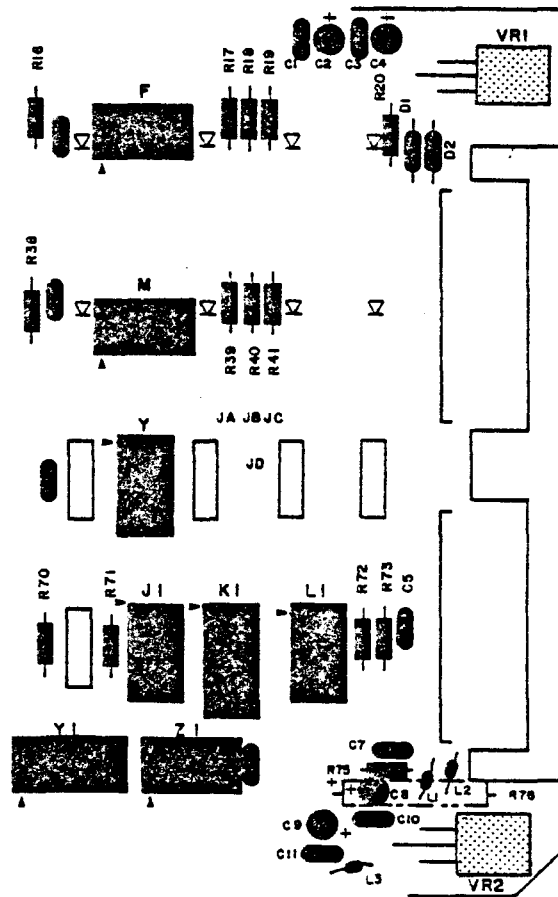

5-19. Display/Control Voltage Regulator Installation



5-30. SWITCH INSTALLATION (Figure 5-20)

There are 25 switches (Bags 7 and 8) to be installed on the Display/Control Board. S2 through S9 are momentary contact switches (i.e. they return to center position automatically when released). SA0 through SA15 and S1 are latching type switches (i.e. they remain in either the up or down position). To insure that all 25 switches are perfectly aligned, the Sub Panel will be temporarily installed at this time. Install the switches according to the following instructions.

NOTE

Set aside 25 of the nuts provided with the switches. The rest of the hardware associated with the switches will not be used.

1. Place one nut over each of the 25 switches. Thread the nuts down as far as they will go. With the notched side facing the bottom edge of the board, insert all 25 switches into the silkscreened side of the board as shown in Figure 5-20A. Do not solder the switches at this time.
2. Place the Sub Panel over the Display/Control Board so that the switches come up through the proper switch holes on the Sub Panel. Secure the Sub Panel in place by placing one 1/4 x 28 nut over each switch (Figure 5-20A).

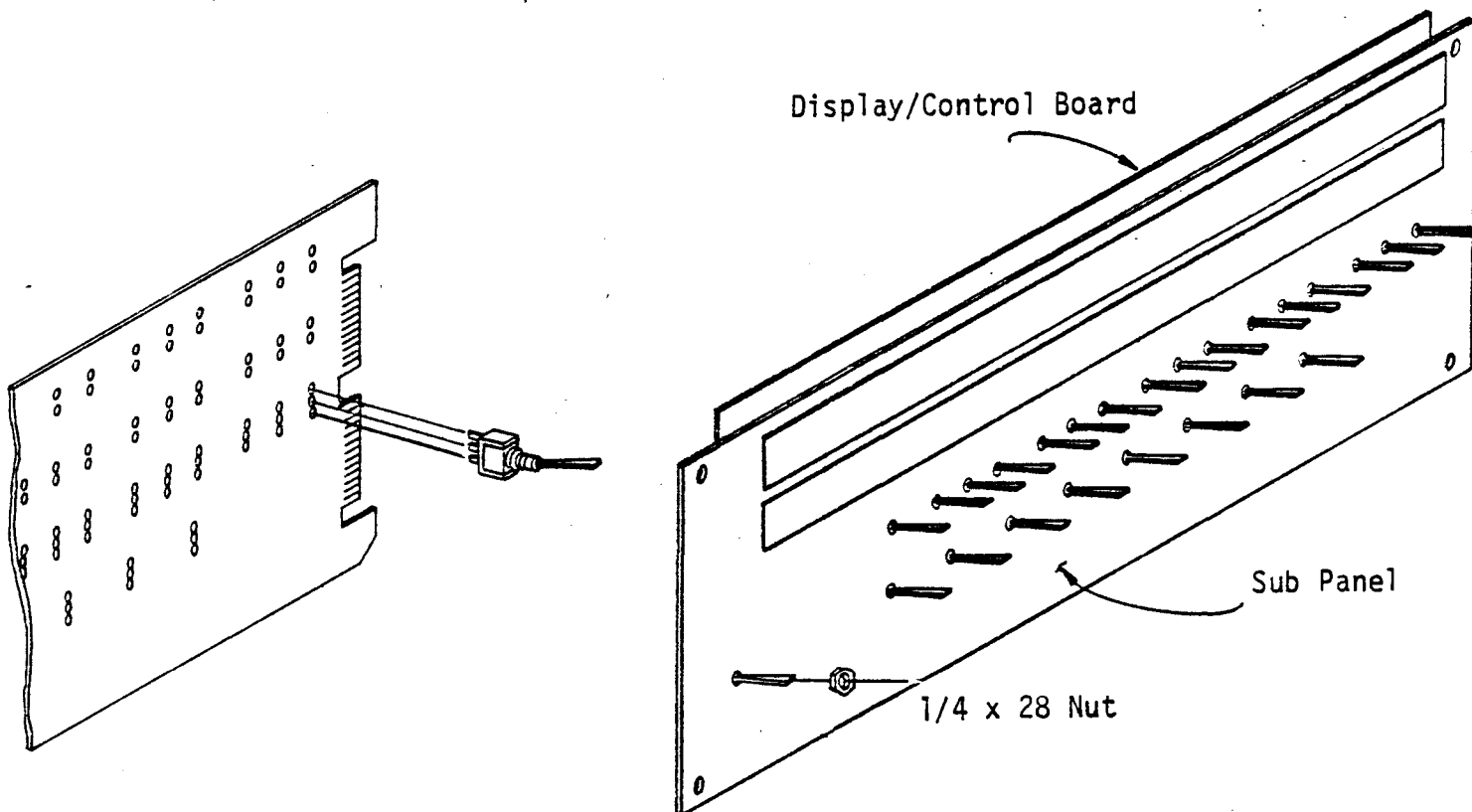

5-20(A). Display/Control Switch Installation

3. Solder all 3 pins of each switch to the foil (bottom) side of the Display/Control Board. Make sure the Display/Control Board is pressed tightly against each switch as it is soldered. If there is any "play" between the switches and the Display/Control Board, the alignment on the final display will not be straight.
4. After all of the switches have been soldered, remove the 25 nuts that were placed on top of the Sub Panel. Set them aside for later use in Paragraph 5-31.
5. Remove the Sub Panel from the Display/Control Board.

| Switch                      | Type                   |
|-----------------------------|------------------------|
| ( ) SA0 through SA15 and S1 | latching type          |
| ( ) S2 through S9           | momentary contact type |

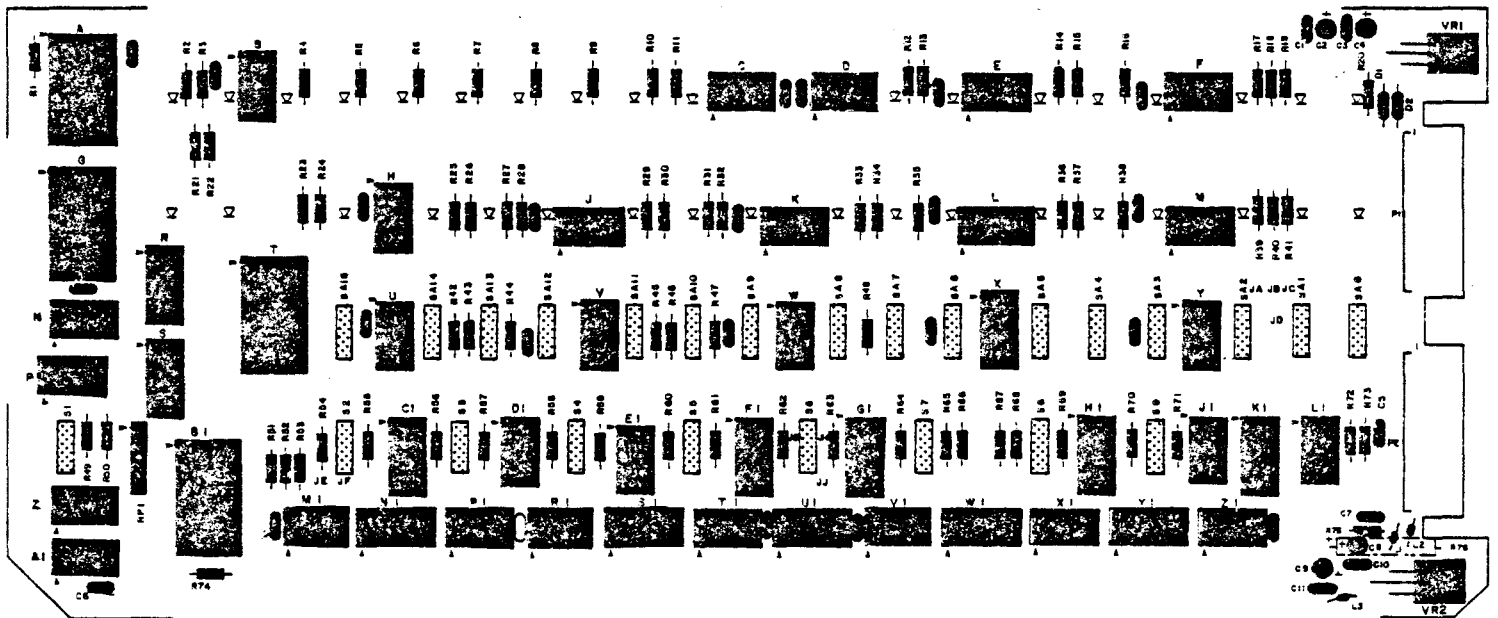

5-20(B). Display/Control Switch Installation

5-31. LED INSTALLATION AND SUB  
PANEL INSTALLATION (Figures  
5-21 through 5-25)

There are 36 LEDs, RL-21 (Bag 9), to be installed on the Display/Control Board. The Sub Panel will also be installed at this time. Install the LEDs and the Sub Panel according to the following instructions.

1. Place one of the nuts saved from Paragraph 5-30 over each of the following switches: SA0, S9, S1, SA15, S5, as shown in Figure 5-21. There should now be two nuts on each of these switches. Thread the nuts down as far as they will go. Place masking tape over the LED holes on the Sub Panel as shown in Figure 5-22.

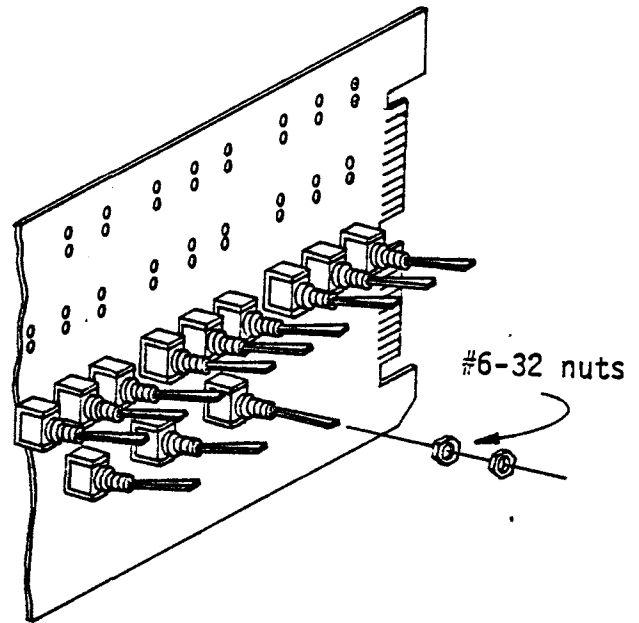

5-21. Display/Control Switch Nut Placement

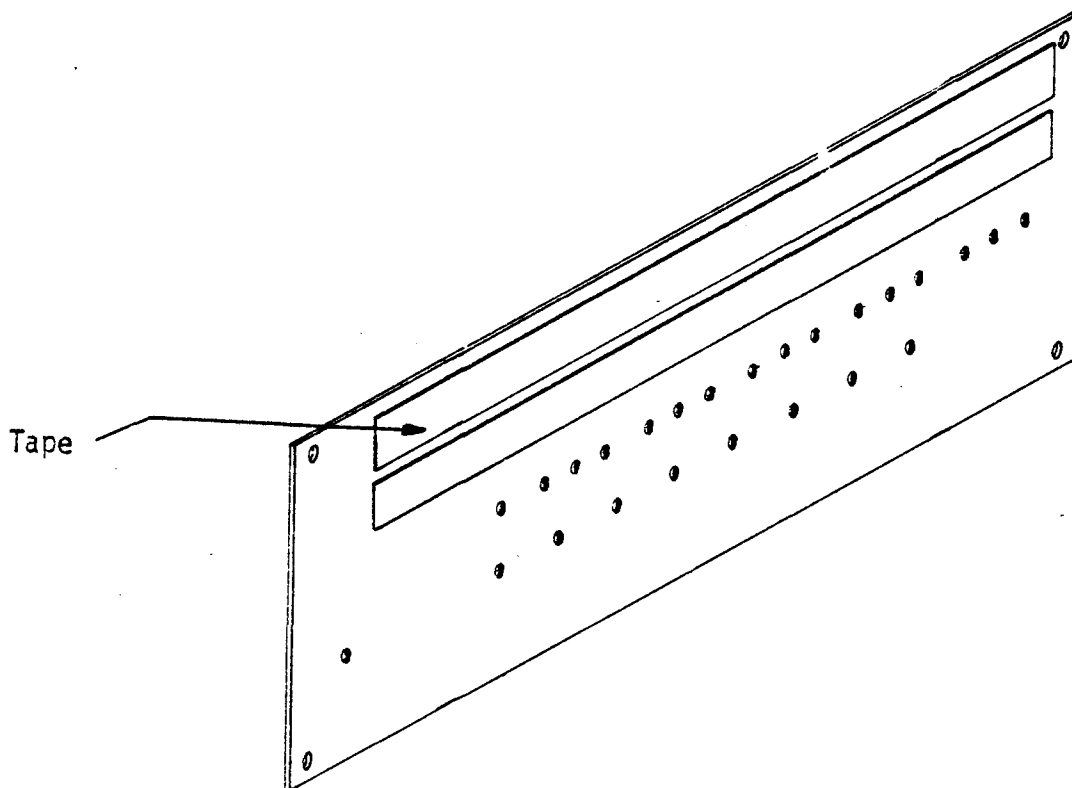

5-22. Covering LED Holes on Sub Panel

RL-21

2. With the cathode lead correctly oriented (Figure 5-23A) insert all 36 LEDs into their respective holes from the silk-screened side of the board, as shown in Figure 5-23B.

NOTE

Do not solder the LED leads at this time.

3. Place the Sub Panel over the Display/Control Panel and tape together as shown in Figure 5-24.

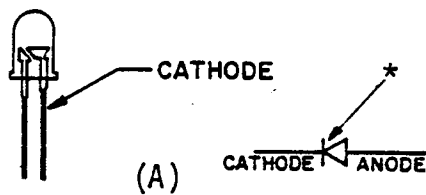

\*Symbol as shown on board.

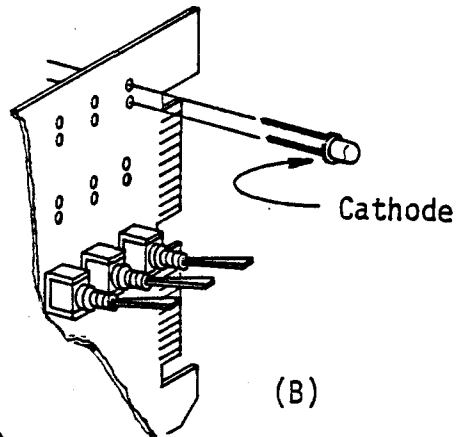

5-23. Display/Control LED Orientation and Installation

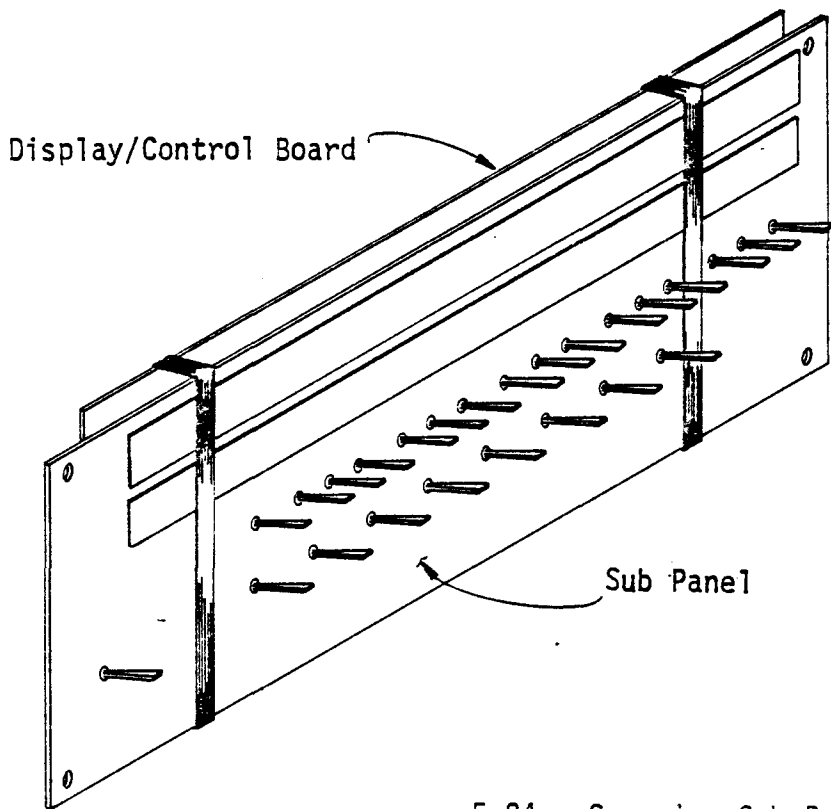

5-24. Securing Sub Panel Over Display/Control Board

- Turn the Sub Panel to the bottom and adjust the LEDs until the top of each LED touches the tape as shown in Figure 5-25.

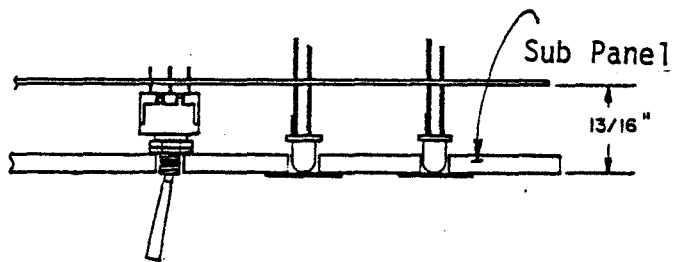

5-25. Display/Control LED Adjustment

- Solder the LED leads to the foil (bottom) side of the Display/Control Board. During this procedure it is advisable to prop the boards from underneath so that the switches are not resting on the work surface.

**WARNING!**

LEDs are heat-sensitive. Use a minimum amount of heat for a minimum length of time when soldering them.

Be sure not to leave any solder bridges, and clip off any excess lead lengths.

- Remove all pieces of masking tape.
- Remove the Sub Panel from the Display/Control Board.
- Remove one nut from SA0, S9, S1, SA15 and S5.
- Place the Sub Panel over the Display/Control Board and secure by placing one nut on the following switches: ON/OFF, RUN/STOP, A15, A8, A0, INPUT/OUTPUT, and DEPOSIT.

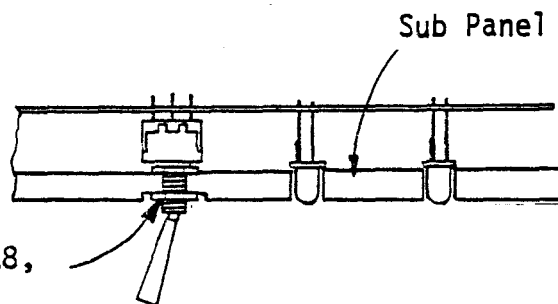

Nut for ON/OFF, RUN/STOP, A15, A8, A0, INPUT/OUTPUT and DEPOSIT switches only.

5-25A. Sub Panel Mounting

5-32. CPU BOARD ASSEMBLY

5-33. IC INSTALLATION (Figure 5-26)

Install the following 17 integrated circuits (Bag 2) on the CPU Board according to the Integrated Circuit Installation Instructions, Section A, given on page 5-10.

NOTE

Do not install ICs A, K, and M at this time. Installation instructions for these ICs are given in Paragraph 5-43.

The following chart lists each integrated circuit, its part number, and acceptable substitutions.

| IC Part Numbers       |                          |
|-----------------------|--------------------------|
| ( ) D,E               | 8216                     |
| ( ) F                 | 8224                     |
| ( ) N,P,R,U,<br>V,W,X | 74367                    |
| ( ) S,Y               | 74LS14 or 74LS04         |
| ( ) C                 | 74LS13 or 74LS20         |
| ( ) B,G               | 74LS04                   |
| ( ) L,J               | 8T98 or 8098<br>or 74368 |

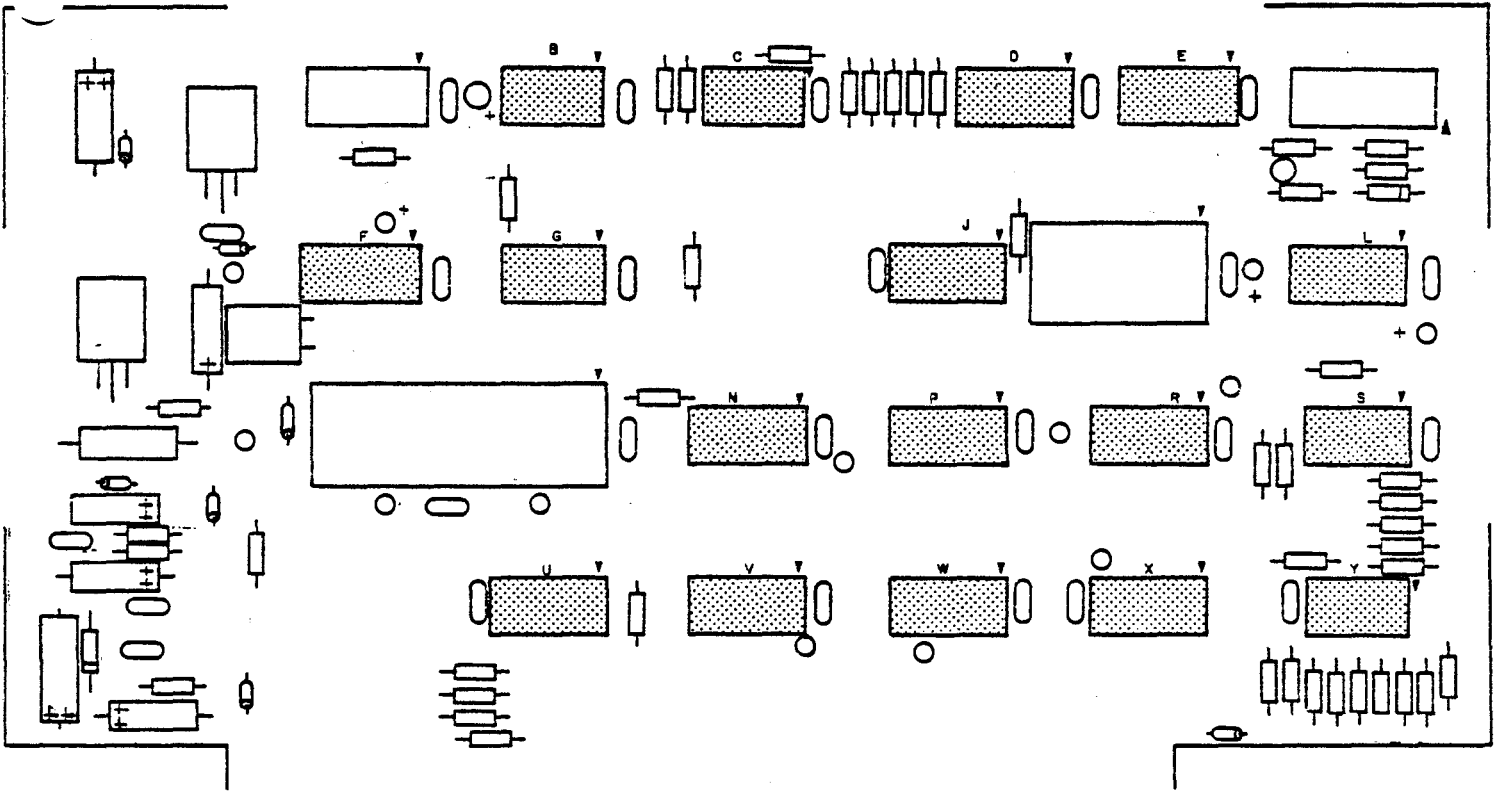

5-26. CPU IC Installation

5-34. RESISTOR INSTALLATION  
(Figure 5-27)

Install the following 46 resistors (Bags 3 and 4) on the CPU Board according to the Resistor Installation Instructions given on page 5-6.

NOTE

Save any excess resistor leads for ferrite bead installation in Paragraph 5-38.

Resistor Values

- |   |  |
|---|--|
| ( ) R3-R7, R11, R13, R14, R19, R20, R24, R25, R28-R33, R39-R43, R50 | 2.2K ohm (red, red, red) 1/2W or 1/4W        |
| ( ) R1, R2, R8, R26, R27, R37, R38, R44-R49                         | 3.3K ohm (orange, orange, red) 1/2W or 1/4W  |
| ( ) R9  | 15K ohm (brown, green, orange) 1/2W or 1/4W  |
| ( ) R16   | 1K ohm (brown, black, red) 1/2W or 1/4W      |
| ( ) R34   | 620 ohm (blue, red, brown) 1/2W              |
| ( ) R10   | 330 ohm (orange, orange, brown) 1/2W or 1/4W |
| ( ) R21, R23  | 470 ohm (yellow, violet, brown) 1/2W or 1/4W |
| ( ) R17   | 10K ohm (brown, black, orange) 1/2W or 1/4W  |
| ( ) R22   | 10 ohm (brown, black, black) 2W              |
| ( ) R15   | 100 ohm (brown, black, brown) 1/2W or 1/4W   |

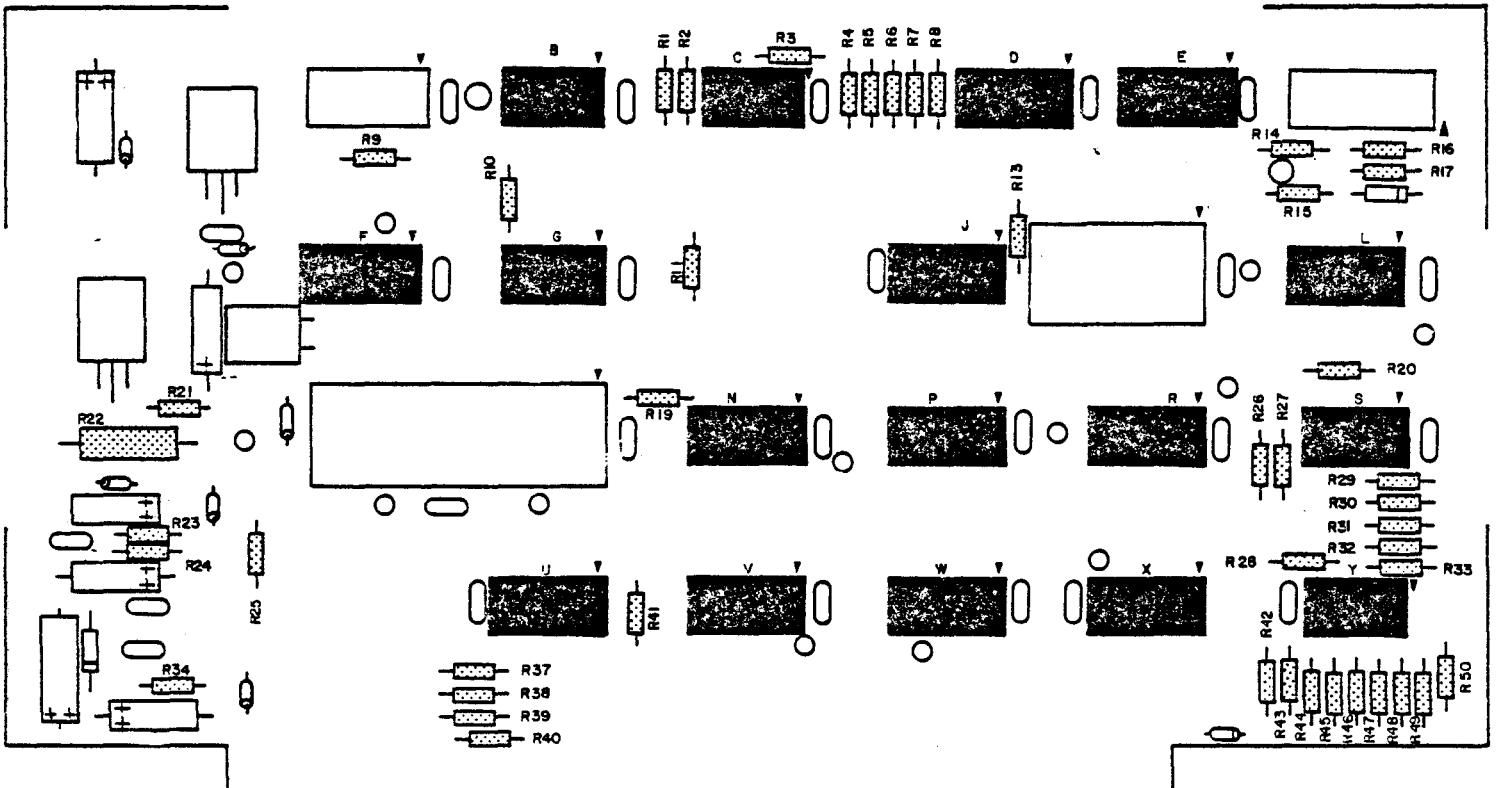

5-35. SUPPRESSOR CAPACITOR INSTALLATION (Figure 5-28)

There are two types of suppressor capacitors to be installed on the CPU Board. The first type, the epoxy dipped tantalum capacitors (Bag 6), are blue on the positive side and are spherical in shape. Be sure to orient the blue side to the "+" sign on the silkscreen before installing each capacitor. The remaining suppressor capacitors are ceramic disk capacitors (Bag 5). They need no polarity orientation. Install both types of capacitors according to the Epoxy Dipped Tantalum and Ceramic Disk Capacitor Installation Instructions given on page 5-7.

| Suppressor Capacitor Values |  |           |
|-----------------------------|--|-----------|
| ( ) 13 dipped tantalum      |  | 1uf, 35V  |
| ( ) 20 ceramic disk         |  | .1uf, 12V |

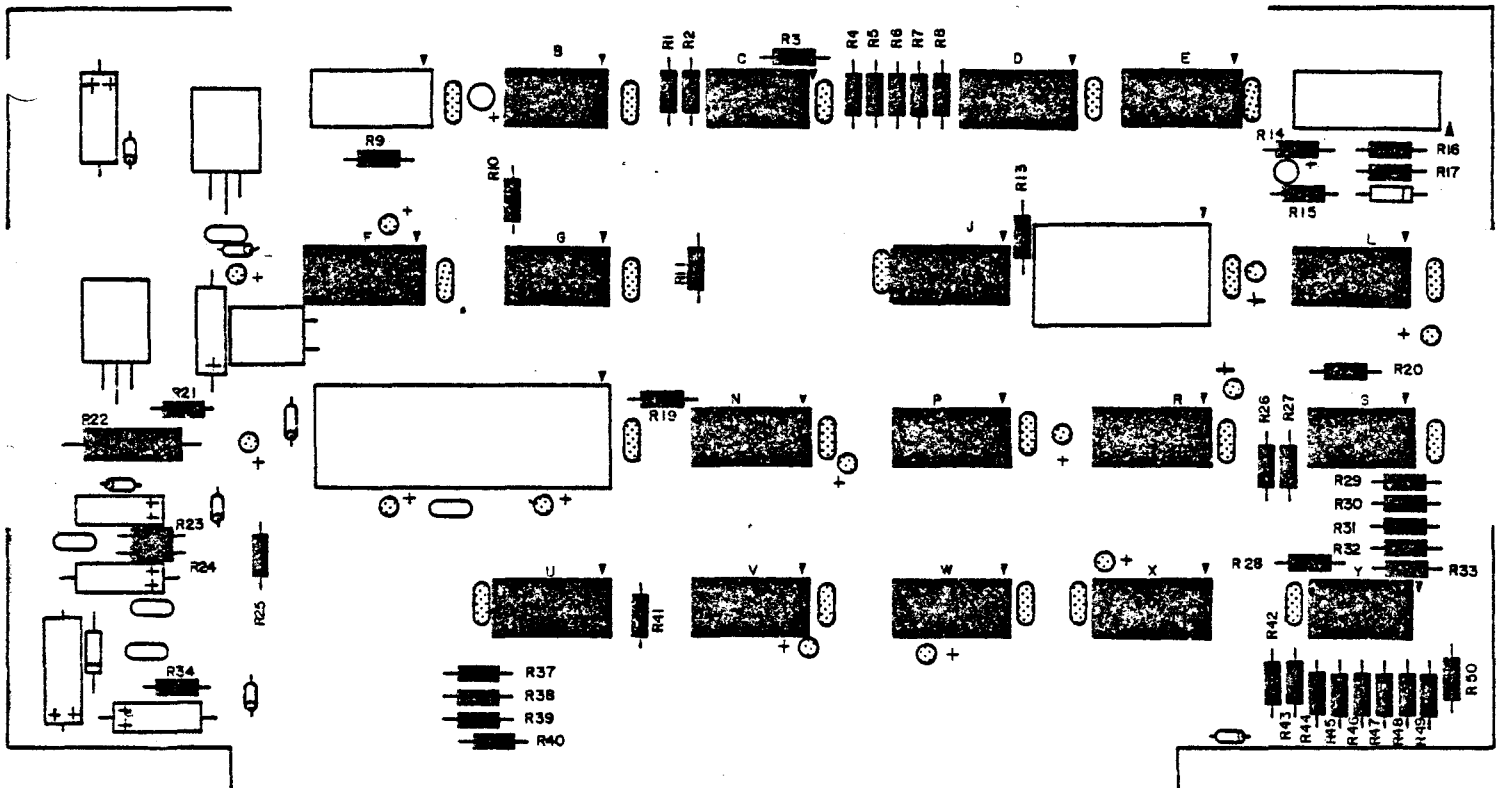

5-28. CPU Suppressor Capacitor Installation



5-36. CAPACITOR INSTALLATION  
(Figure 5-29)

There are 2 dipped tantalum capacitors, 6 electrolytic capacitors, 2 ceramic disk capacitors, and 3 dipped ceramic capacitors (Bag 6) to be installed on the CPU Board. Install each capacitor according to the instructions given on page 5-7.

NOTE

When installing the dipped tantalum and the electrolytic capacitors, be sure the positive lead is installed in the "+" hole on the silkscreen.

Capacitor Values

|                     |                               |
|---------------------|-------------------------------|
| ( ) C1, C5, C6, C11 | 33uf, 16V, electrolytic       |
| ( ) C2              | 22uf, 16V, dipped tantalum    |
| ( ) C3, C7, C10     | .1uf, 50V, dipped ceramic     |
| ( ) C4              | 10uf, 16V, dipped tantalum    |
| ( ) C8, C12         | .1uf, 12V - 16V, ceramic disk |
| ( ) C9, C13         | 10uf, 25V, electrolytic       |

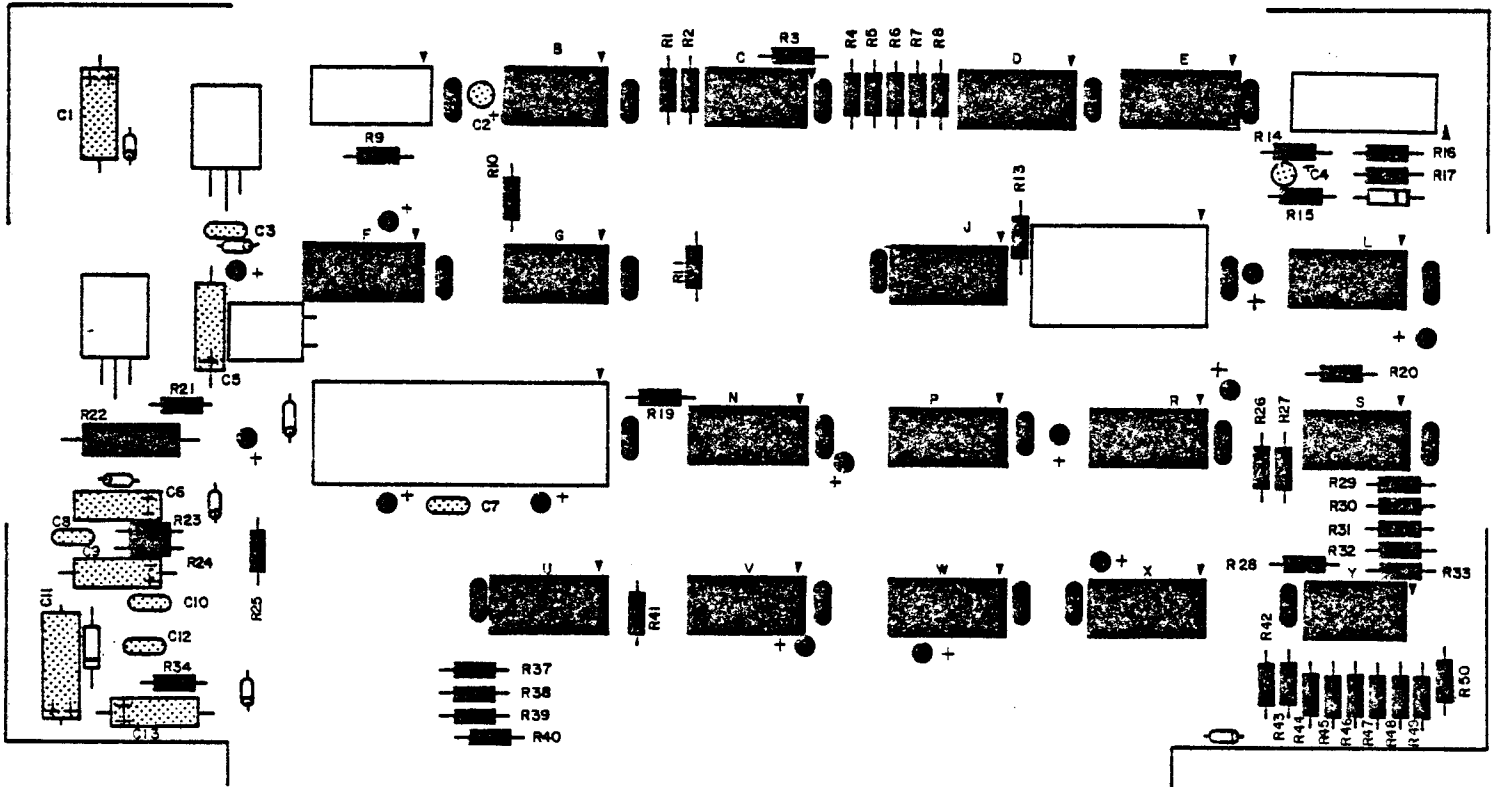

5-29. CPU Capacitor Installation

5-37. DIODE INSTALLATION (Figure 5-30)

Install the two diodes, D1 and D2 (Bag 4), on the CPU Board according to the Diode Installation Instructions given on page 5-8.

| Diode Part Numbers |        |
|--------------------|--------|
| ( ) D1             | 1N4730 |
| ( ) D2             | 1N4733 |

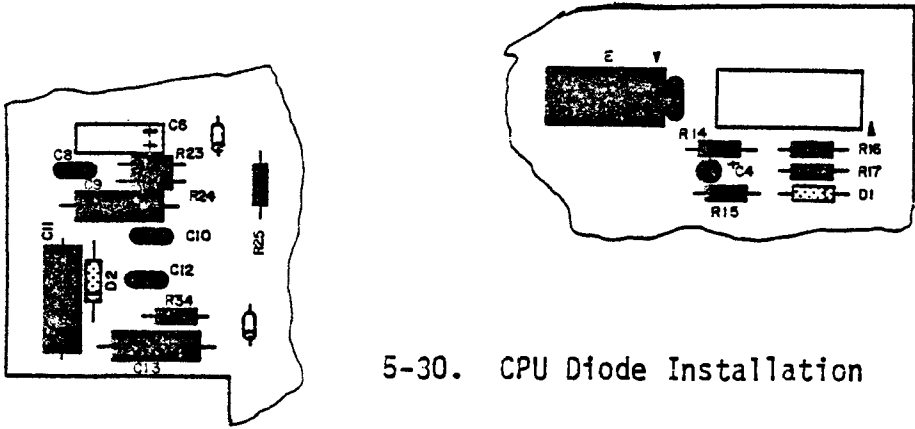

5-30. CPU Diode Installation

5-38. FERRITE BEAD INSTALLATION  
(Figure 5-31)

Install the 7 ferrite beads, L1 through L7 (Bag 7), on the CPU Board according to the following instructions.

1. Using the resistor leads saved from Paragraph 5-34, cut seven 1-inch lead lengths.

2. Insert the lead through the bead, and bend the ends so they conform to the designated holes on the CPU Board.
3. Insert the leads into the board, and solder to the foil (bottom) side of the board. Be careful not to leave any solder bridges.
4. Clip off any excess lead lengths.

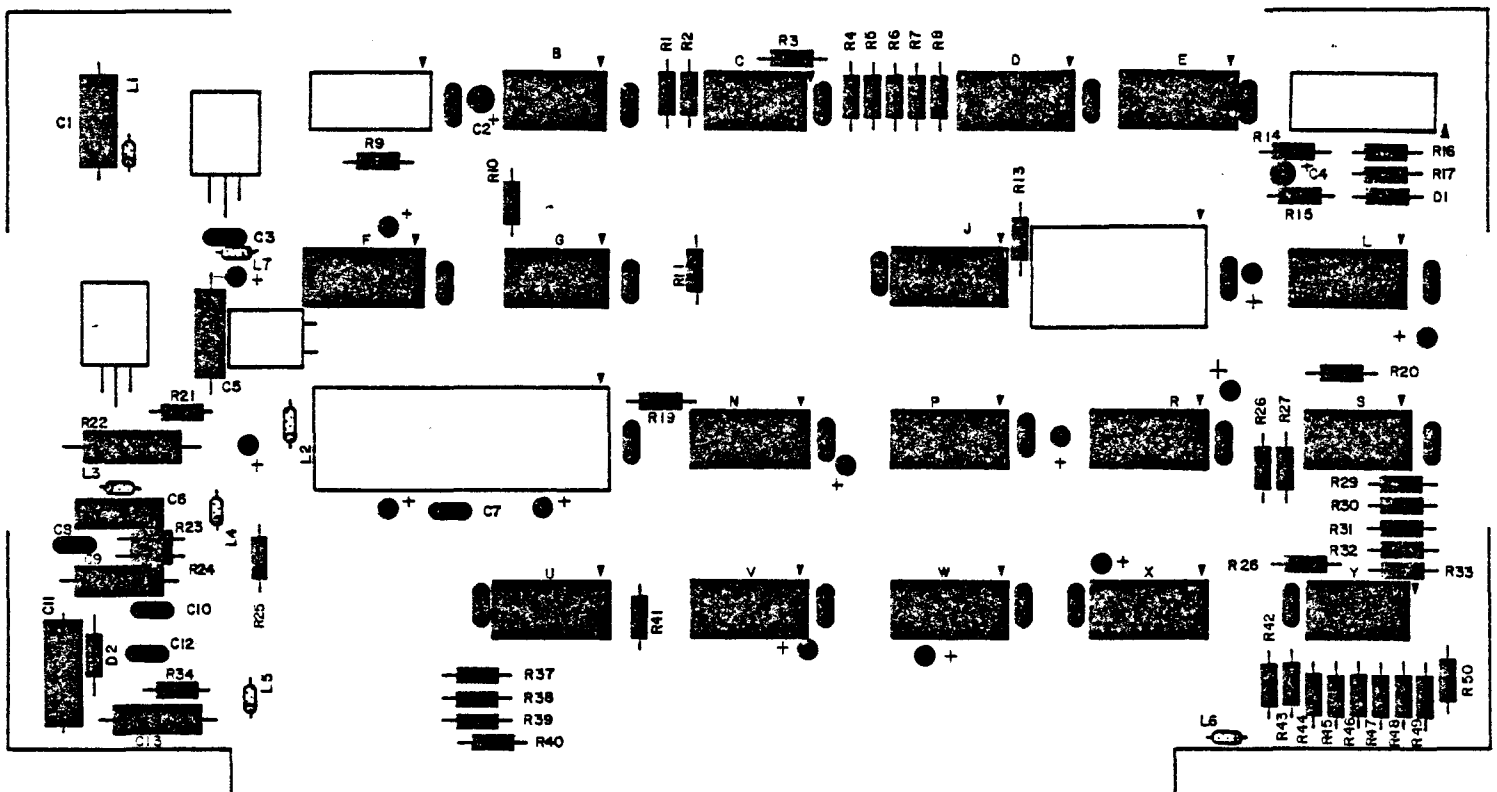

5-31. CPU Ferrite Bead Installation

5-39. VOLTAGE REGULATOR INSTALLATION (Figure 5-32)

Install the two voltage regulators, VR1 and VR2 (Bag 2), and heat sinks on the CPU Board according to the following instructions.

1. Set the regulator in place on the silk-screened side of the board, aligning the leads with their designated holes.
2. Use needle-nose pliers to bend each of the three leads at a right angle to conform to its proper hole on the board.

**NOTE**

Use heat sink grease when installing this component. Apply the grease to all metal surfaces which come in contact with each other.

3. Referring to Figure 5-32, set the regulator and heat sink in place on the silk-screened side of the board. Secure them in place with a #6-32 x 3/8" screw, a #6-32 nut, and a #6 lockwasher.
4. Solder the three leads to the foil (bottom) side of the board. Be sure not to leave any solder bridges.
5. Clip off any excess lead lengths.

| Voltage Regulator Part Numbers |      |
|--------------------------------|------|
| ( ) VR1                        | 7805 |
| ( ) VR2                        | 7812 |

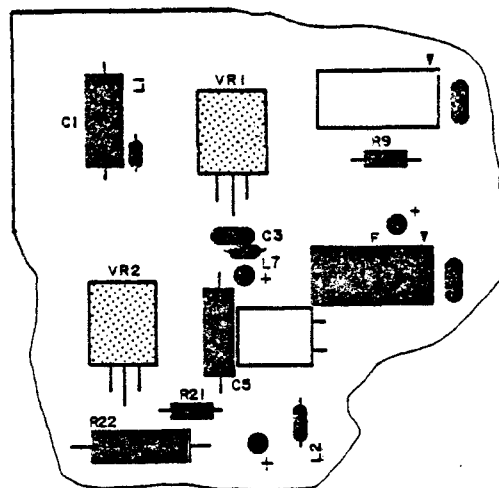
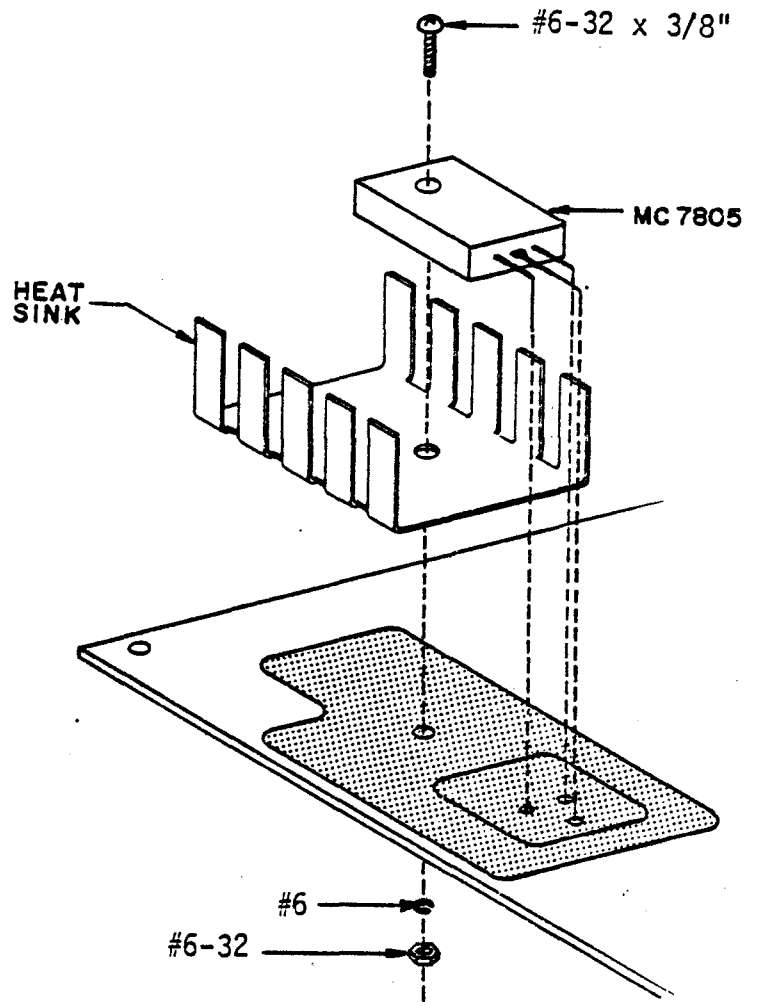

5-32. CPU Voltage Regulator Installation

5-40. TRANSISTOR INSTALLATION  
(Figure 5-33)

Install the three transistors, Q1 through Q3 (Bag 4), on the CPU Board according to the Transistor Installation Instructions given on page 5-8.

| Transistor Part Numbers |                  |
|-------------------------|------------------|
| ( ) Q1, Q2, Q3          | 2N4410 or CS4410 |

NOTE

The 10-pin Male Connector (P1) may already be installed on the CPU board. If so, disregard the following instructions.

5-41. MALE CONNECTOR INSTALLATION  
(Figure 5-33)

Install one 10-pin Male Connector, P1 (Bag 7), on the CPU Board according to the following instructions.

1. Orient the connector as shown in Figure 5-33, with the bent pins pointing toward the top of the board.
2. Insert the short pins into the 10 designated holes on the silk-screened side of the board.
3. Solder each pin to the foil (bottom) side of the board. Be sure not to leave any solder bridges and clip off any excess lead lengths.
4. The arrow on the silkscreen points to Pin #1. After installing the male connector, clip off pin #2 of the connector. This is done for keying purposes. Further keying instructions are given on page 5-75.

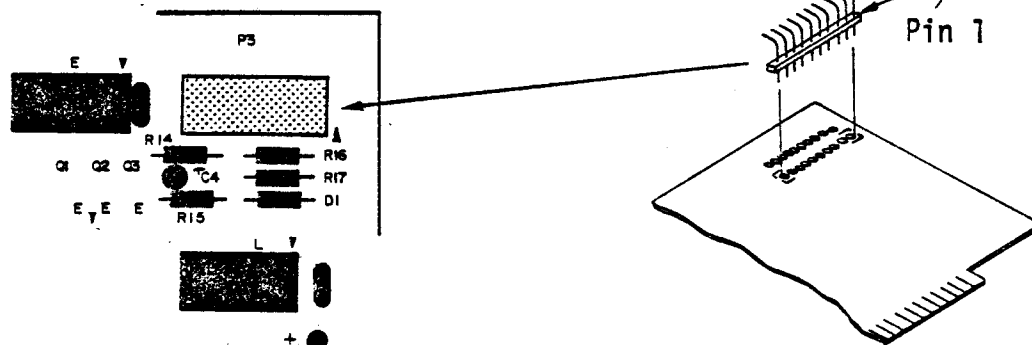

5-33. CPU Transistor and Male Connector Installation

5-42. CRYSTAL INSTALLATION (Figure 5-34)

Install one 18.00000 MHz crystal, XTAL (Bag 7), on the CPU Board according to the following instructions.

1. Referring to Figure 5-34, set the crystal in place on the silk-screened side of the CPU board, aligning the two leads with their respective holes.
  2. Using needle-nose pliers, bend each lead at a right angle to conform to its respective hole on the board. Insert the leads so that the crystal is resting flat on the board on the square labelled "XTAL".
  3. Solder the two leads to the foil (bottom) side of the board. Be sure not to leave any solder bridges.
- Clip off any excess lead lengths.

**CAUTION**

Make sure the crystal case does not come in contact with any of the tracks on the CPU Board.

| Crystal  | Part Number |
|----------|-------------|
| ( ) XTAL | 18.00000MHz |

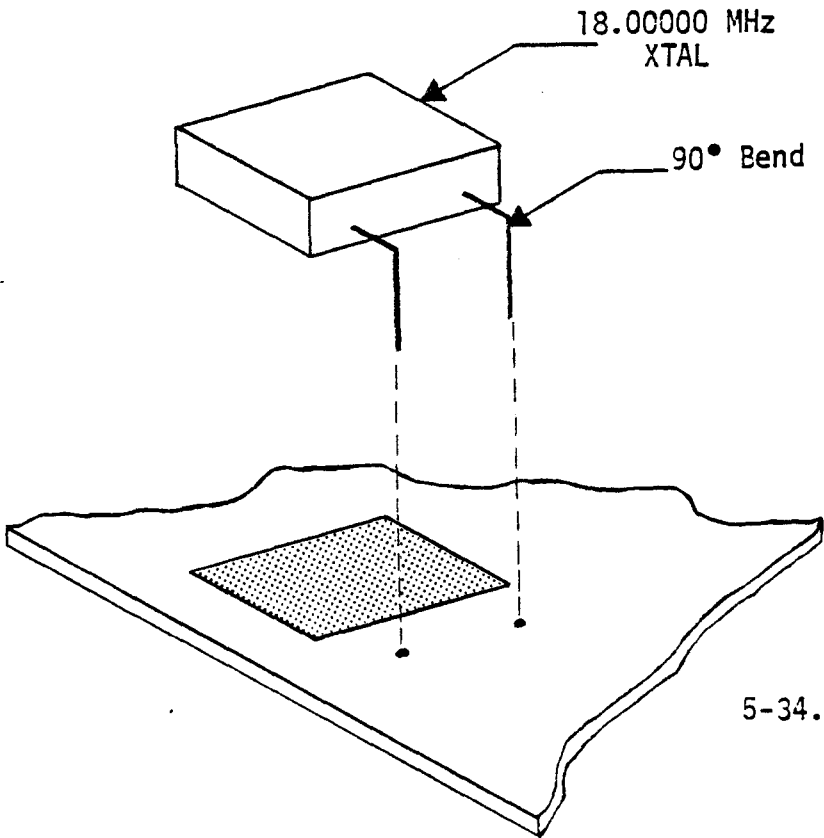
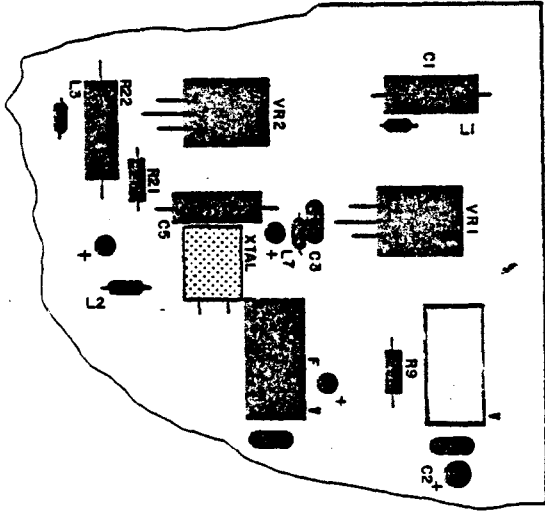

5-34. CPU Crystal Installation

5-43. IC SOCKET AND IC INSTALLATION  
 (Figure 5-35)

ICs A, K, and M (Bag 1) will be installed at this time. ICs K and M should be installed, with sockets, according to the IC Installation Instructions, Section B, on page 5-10. IC A should be installed (without a socket) according to the IC Installation Instructions, Section A, on page 5-10.

| Silkscreen Designation | IC Part Number | Socket Size |
|------------------------|----------------|-------------|
| ( ) K                  | 8212           | 24-pin      |
| ( ) M                  | 8080           | 40-pin      |
| ( ) A                  | 4009           | -----       |

**WARNING!**

ICs A and M are MOS static-sensitive ICs. See the "MOS IC Special Handling Precautions" on page 5-11 before installing these ICs.

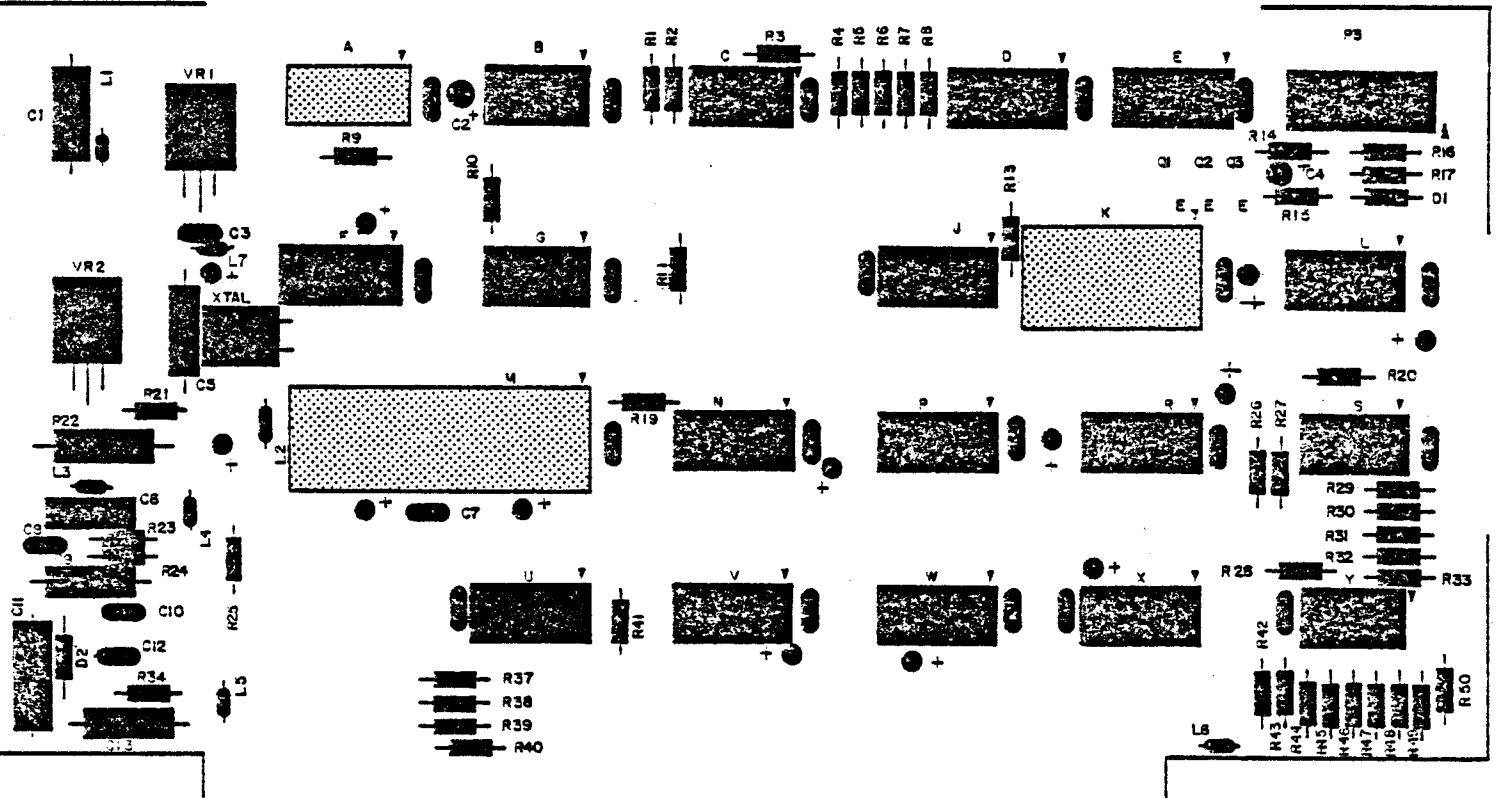

5-35. CPU IC Socket and IC Installation

5-44. POWER SUPPLY BOARD ASSEMBLY

5-45. CAPACITOR INSTALLATION  
(Figure 5-36)

Install the 4 electrolytic capacitors, C1 through C4 (Bag 3), on the Power Supply Board according to the Capacitor Installation Instructions given on page 5-7.

| Capacitor Values  |                           |
|-------------------|---------------------------|
| ( ) C1 through C4 | 2200uf, 25V, electrolytic |

5-46. RESISTOR INSTALLATION  
(Figure 5-36)

Install the 2 resistors, R1 and R2 (Bag 1), on the Power Supply Board according to the Resistor Installation Instructions given on page 5-6.

| Resistor Values |                                   |
|-----------------|-----------------------------------|
| ( ) R1 and R2   | 180 ohm (brown, gray, brown) 1/2W |

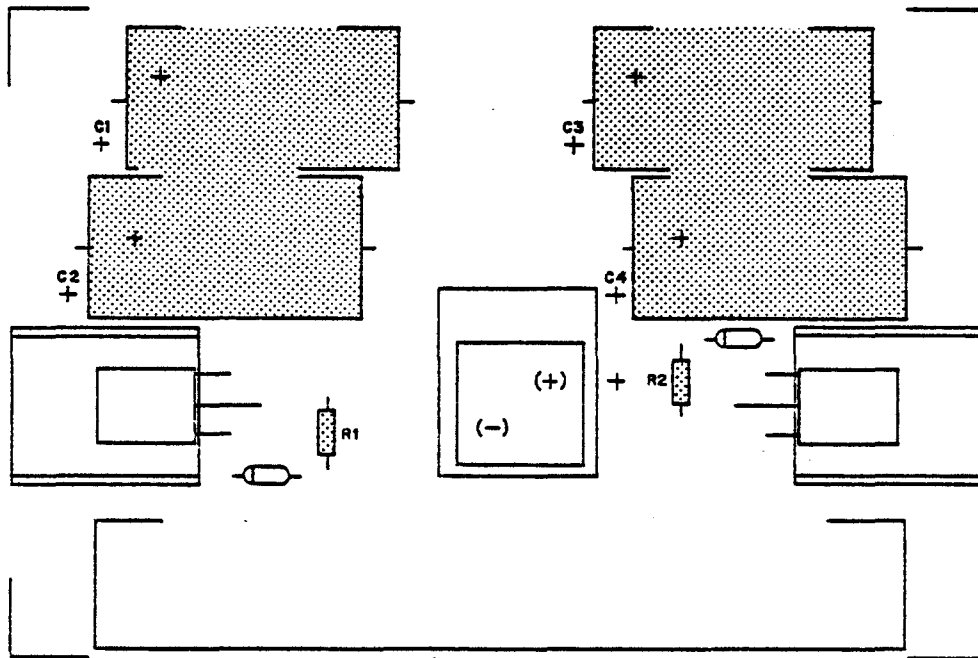

5-36. Power Supply Capacitor and Resistor Installation



5-47. DIODE INSTALLATION (Figure 5-37)

Install the 2 diodes, D1 and D2 (Bag 1), on the Power Supply Board according to the Diode Installation Instructions given on page 5-8.

|                    |        |
|--------------------|--------|
| Diode Part Numbers |        |
| ( ) D1 and D2      | IN4746 |

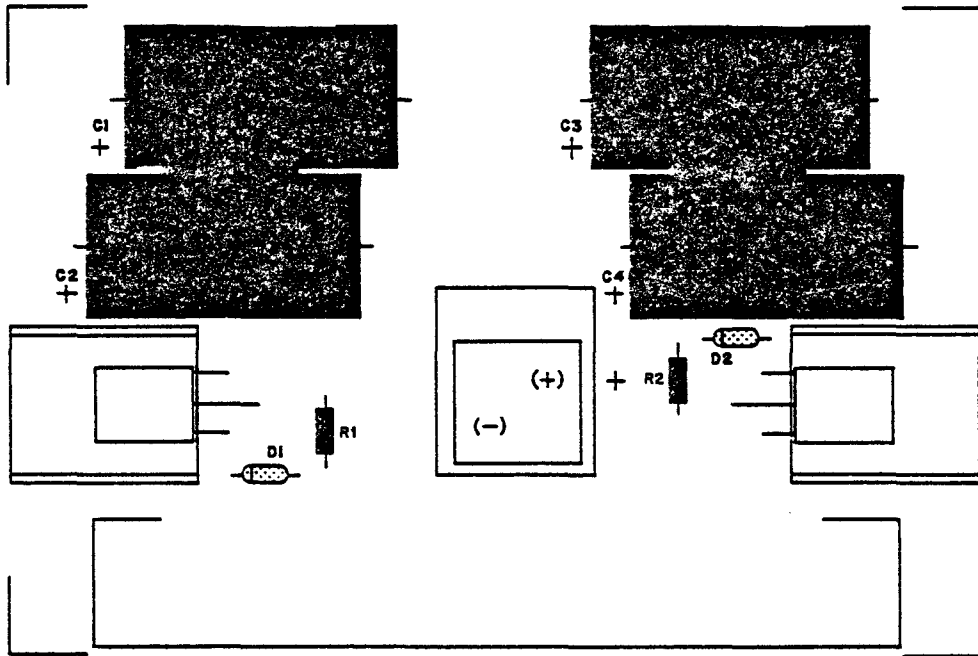

5-37. Power Supply Diode Installation

5-48. TRANSISTOR INSTALLATION  
(Figure 5-38)

Install the two transistors, Q1 and Q2 (Bag 1), mica insulators, and heat sinks on the Power Supply Board according to the following instructions.

1. Set the transistor in place on the silk-screened side of the board, aligning the leads with their designated holes.
2. Use needle-nose pliers to bend each of the three leads at a right angle to conform to its proper hole on the board.

**NOTE**

Use heat sink grease when installing this component. Apply the grease to all surfaces which come in contact with each other.

**NOTE**

According to supply variations, your kit may contain either two #6-32 x 3/8" nylon screws (Bag 5), or two #4-40 x 3/8" metal screws (Bag 5) to be used when installing transistors Q1 and Q2. If your kit contains metal screws, two fiber shoulder washers (Bag 5) must be used along with the screws. To install the fiber shoulder washers, refer to Figure 5-38.

3. Referring to Figure 5-38, set the transistor, mica insulator, and heat sink in place on the silkscreened side of the board. Secure them in place with a #6-32 x 3/8" screw, a #6 lock-washer and a #6-32 nut (Bag 5).

4. Solder the three leads to the foil (bottom) side of the board. Be sure not to leave any solder bridges.

5. Clip off any excess lead lengths.

| Transistor Part Numbers |                  |
|-------------------------|------------------|
| ( ) Q1                  | TIP145 or TIP146 |
| ( ) Q2                  | TIP140 or TIP141 |

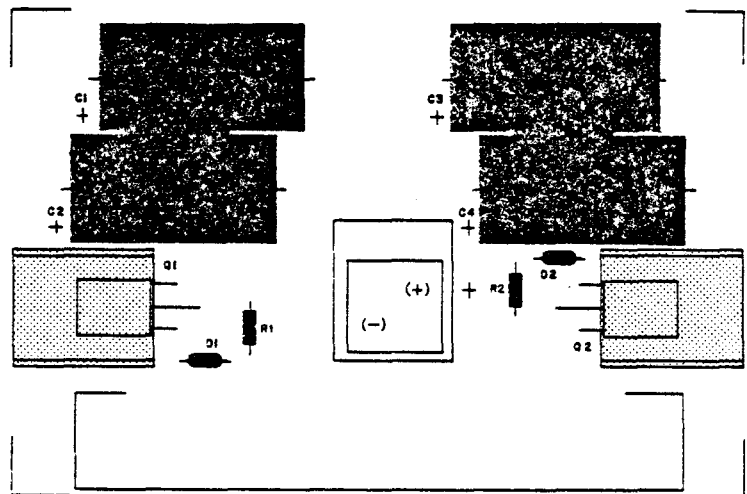
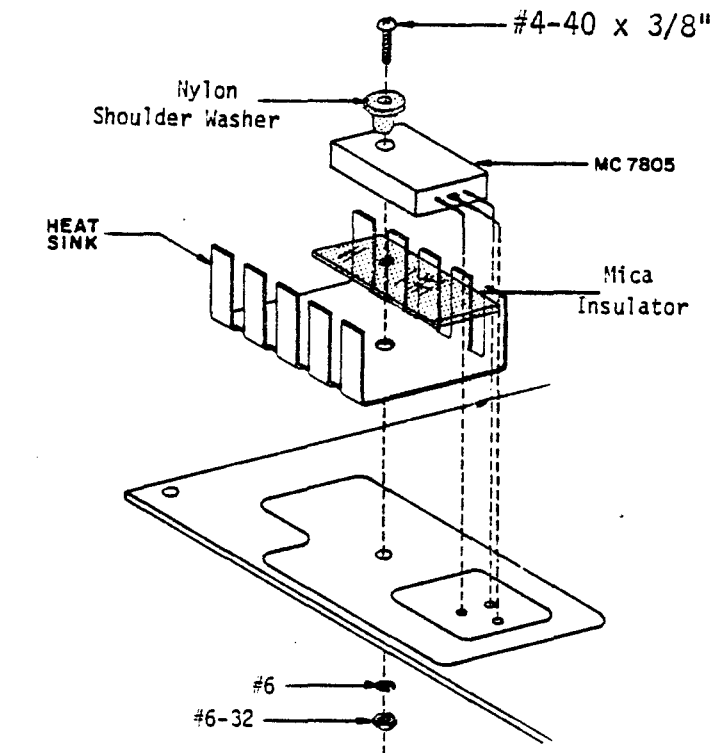

5-38. Power Supply Transistor Installation

5-49. BRIDGE RECTIFIER INSTALLATION (Figure 5-39)

Install one bridge rectifier, BR2 (Bag 1), on the Power Supply Board according to the following instructions.

**WARNING!**

It is essential that the bridge rectifier be oriented correctly, so that the "+" lead or red dot corresponds with the "+" hole on the Power Supply Board.

**NOTE**

Use heat sink grease when installing this component. Apply the grease to the bridge rectifier and the heat sink where they come in contact with each other.

1. Orient the bridge rectifier and the heat sink as shown in Figure 5-39. Note that the mounting hole in the heat sink is not centered, but is closer to one end. Make sure you orient the "+" lead of the rectifier under the wider end of the heat sink, as shown.
2. Attach the heat sink to the bridge rectifier, using a #6-32 x 1/2" screw and a #6 hex nut (Bag 5).
3. Orient the heat sink and rectifier assembly correctly over the board, as shown in Figure 5-39. When you have the proper alignment, the wider end of the heat sink will be pointing toward the right side of the Power Supply Board, and the "+" lead will be going into the "+" hole.

4. Insert the four leads from the bridge rectifier through the proper holes on the Power Supply Board until the legs of the heat sink rest on the board.
5. Holding the heat sink in place, turn the board over and bend the four leads slightly outward. Solder the leads to the foil (bottom) side of the board and clip off any excess lead lengths.

| Bridge Rectifier | Part Number |
|------------------|-------------|
| ( ) BR2          | KBPC802     |

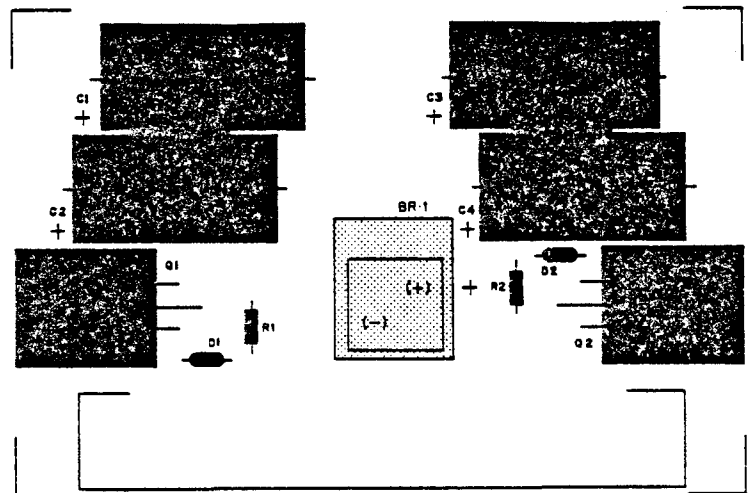
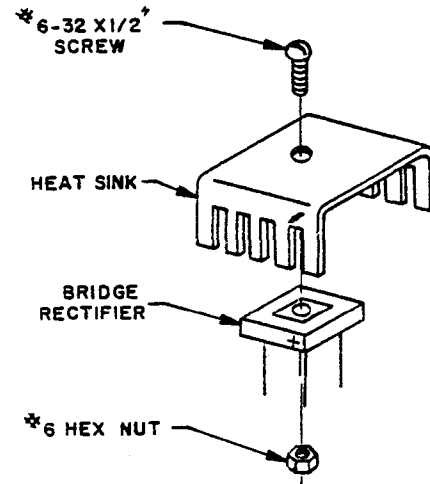

5-39. Power Supply Bridge Rectifier Installation

5-50. TERMINAL BLOCK INSTALLATION  
(Figures 5-40 through 5-42)

Install the terminal block, TB1 (Bag 2), on the Power Supply Board according to the following instructions.

1. Remove the five #6-32 x 1/4" screws shown in Figure 5-40 from the terminal block.
2. Set the terminal block in place on the silk-screened side of the Power Supply Board.
3. Secure the terminal block onto the board by inserting nine #6-32 x 9/16" or #6-32 x 5/8" screws, nine #6 lockwashers, and nine #6 nuts (Bag 5) into the proper holes as shown in Figure 5-41.
4. Insert 1 shorting link (Bag 2) over the lower portion of terminals 7 and 8, and 1 shorting link over the upper portion of terminals 8 and 9. Secure in place with four #6-32 x 1/4" screws (Figure 5-42).

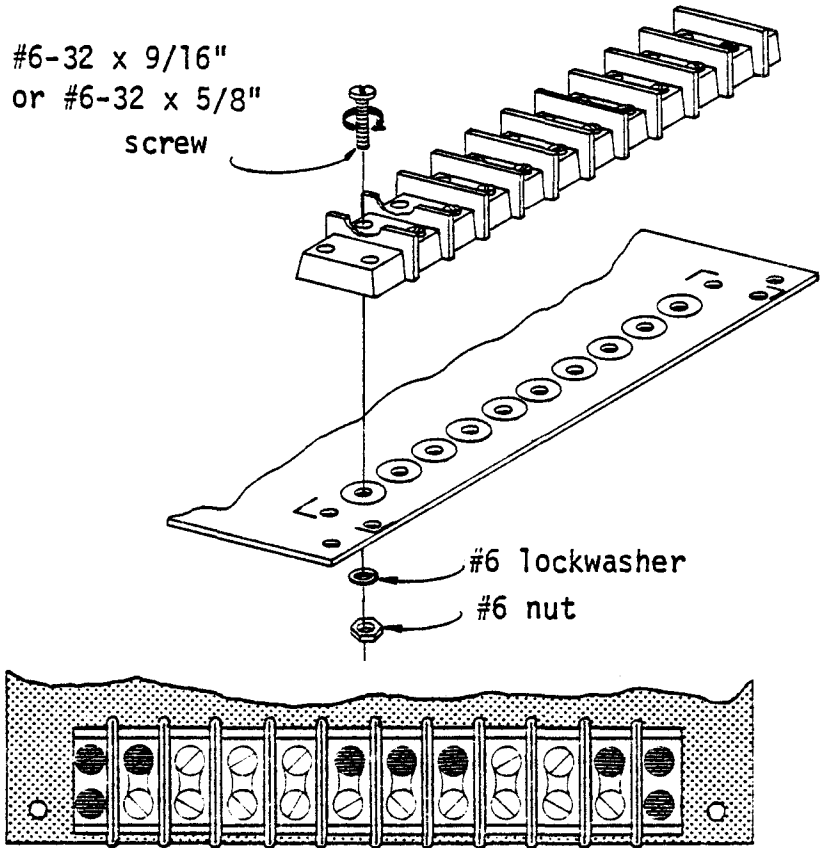

5-41. Power Supply Terminal Block Screw Insertion

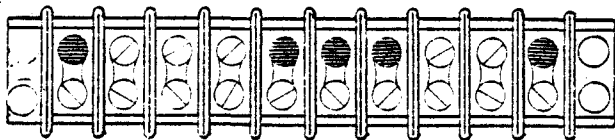

5-40. Power Supply Terminal Block Screw Removal

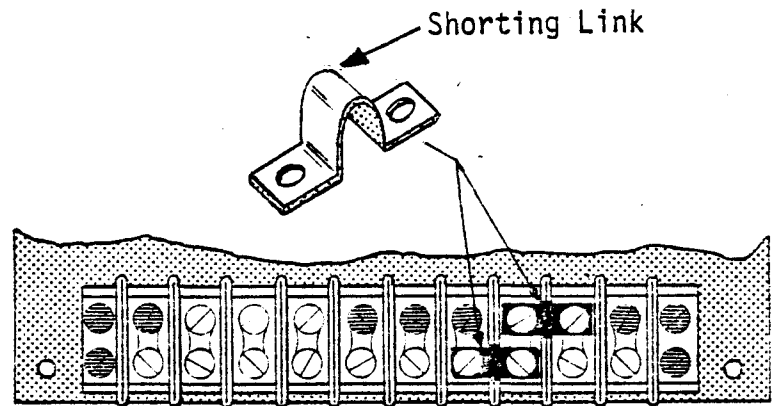

5-42. Power Supply Terminal Block Shorting Link Insertion

5-51. MOUNTING POWER SUPPLY BOARD  
ONTO CROSS MEMBER (Figure  
5-43)

There are four or five holes on the Power Supply Board to be used in mounting the board to the Cross Member at the back of the main frame. Five 3/4" threaded spacers (Bag 5) and ten #6-32 x 3/8" screws (Bag 5) will be used in this procedure. Refer to Figure 5-43 and the following instructions for mounting the board to the Cross Member.

1. Insert one screw into each mounting hole on the board from the silk-screened side.
2. Put a spacer on each screw and tighten it down.
3. Rest the board on the Cross Member so that the spacers are aligned with the mounting holes.

4. Fasten the board into place by inserting another screw into each spacer from underneath the Cross Member.

NOTE

Before mounting the Power Supply Board, make a ground connection between terminal #9 on the terminal block and the lower, right-hand mounting screw on the cross member. Use a 3-inch piece of wire braid with solder lugs at each end. (Instructions for preparing the wire braid are detailed in Paragraph 5-72.)

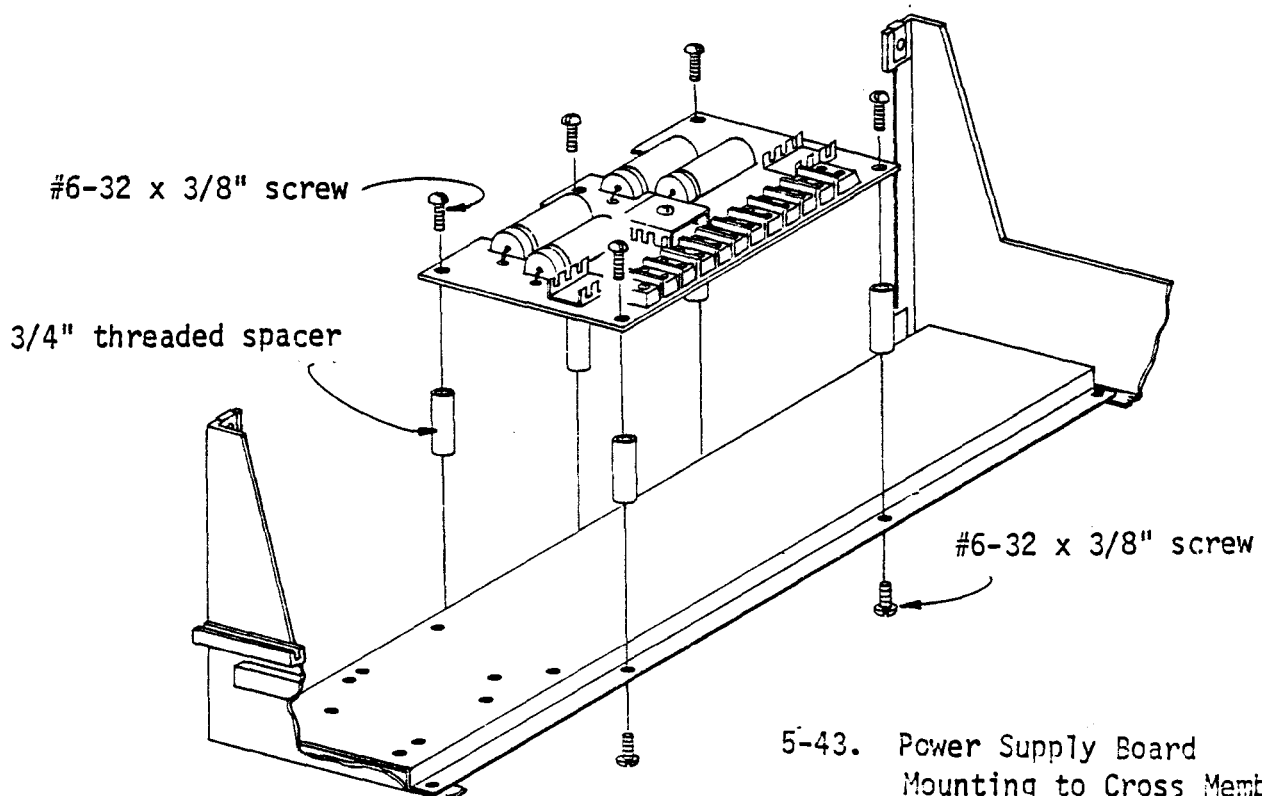

5-43. Power Supply Board  
Mounting to Cross Member

5-52. CAPACITOR AND CAPACITOR CLAMP INSTALLATION (Figures 5-44 and 5-45)

According to supply variations, your kit may contain either one capacitor (varying from 80,000uf - 100,000uf, 15V - 25V) or two capacitors (varying from 40,000uf - 50,000uf, 15V - 25V) to be mounted on the Cross Member. Figure 5-44 shows the proper placement for one capacitor. Figures 5-45A and 5-45B show the proper placement for two capacitors. The capacitor(s) are mounted in clamps using a #6-32 x 3/8" screw and a #6-32 nut (Bag 5).

Install the capacitor(s) according to the following instructions.

1. Secure the capacitor in the clamp with a #6-32 x 3/8" screw and orient the capacitor as shown in figure.
2. Place the clamp and capacitor on the Cross Member, aligning the mounting holes.
3. Secure the clamp to the Cross Member using three #6-32 x 3/8" screws and three #6-32 nuts.

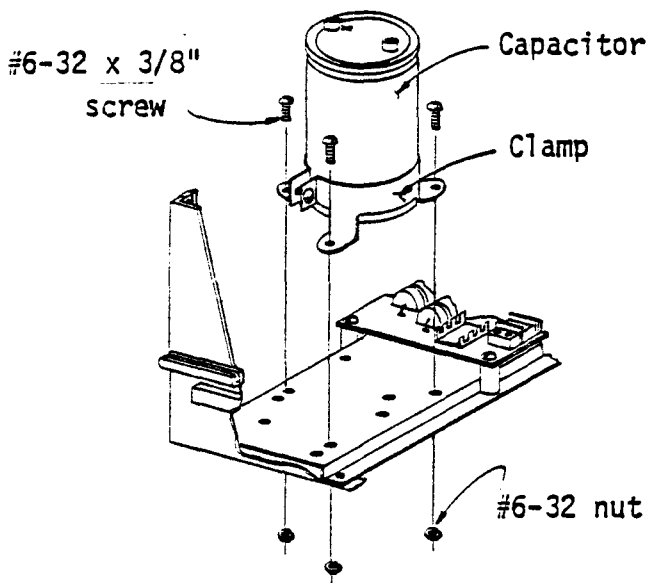

5-44. Power Supply Capacitor and Clamp Installation (For One Capacitor)

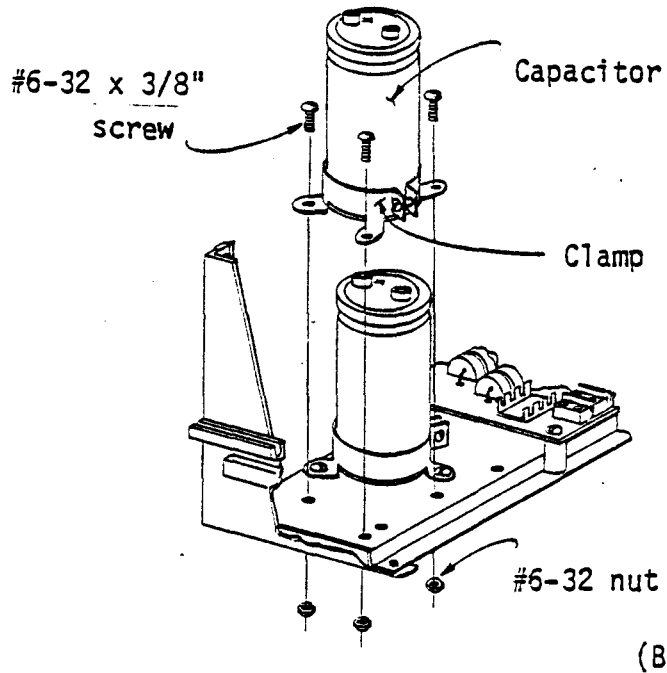
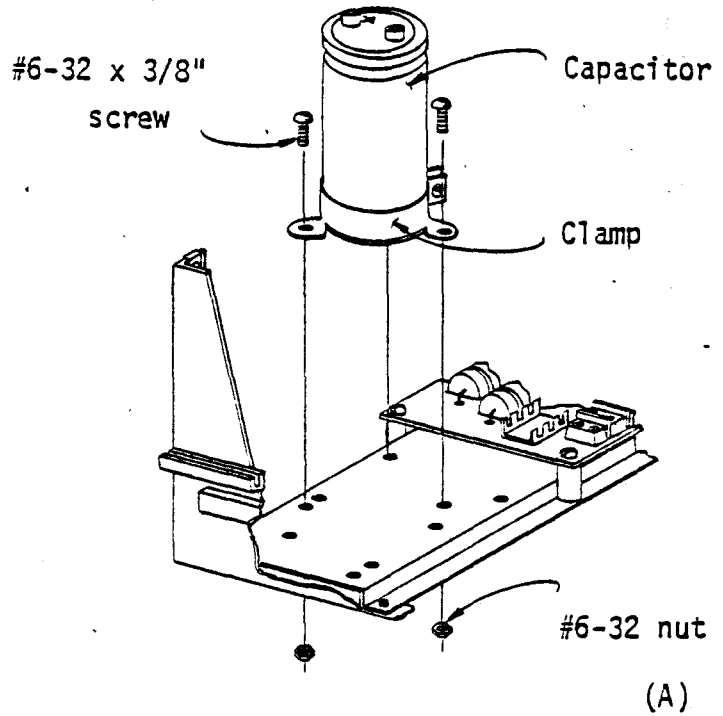

5-45. Power Supply Capacitor and Clamp Installation (For Two Capacitors)

5-53. BACK PANEL ASSEMBLY (Figure 5-46)

The instructions for the assembly of the Altair 8800b back panel are divided into the following sections:

- Procedural Instructions
- Capacitor Wiring
- Bridge Rectifier Installation
- I/O Connectors
- Fan Mounting
- Fuse and Fuse Holder
- AC Power Cord
- Transformer
- Back Panel Mounting

Before beginning the back panel assembly, remove the back panel from the mainframe and remove the mainframe from the case bottom. Set aside the mounting screws, as they will be replaced later in the assembly procedure.

To aid with the assembly of your unit, a view of a correctly assembled back panel is shown below in Figure 5-46.

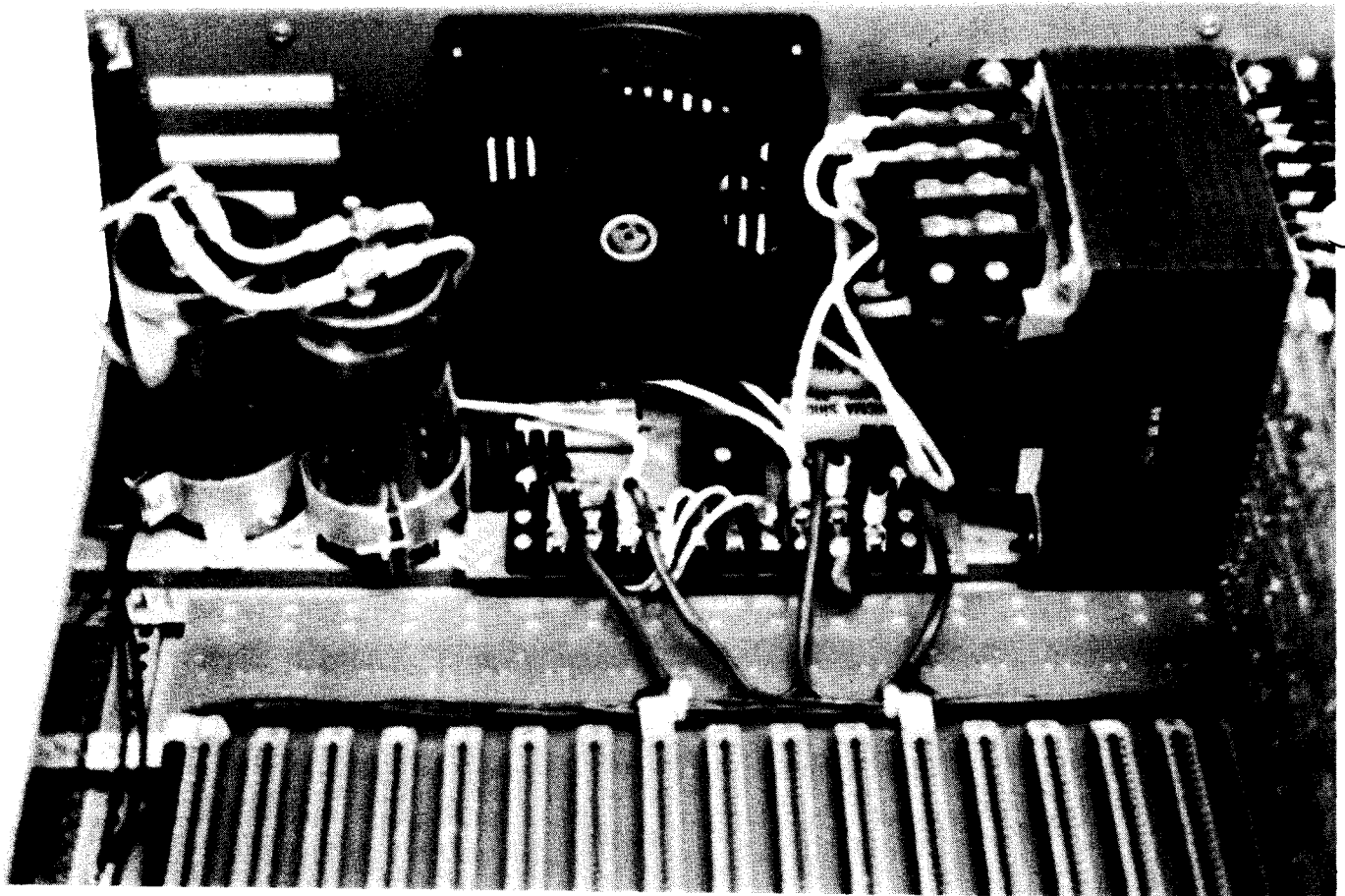

Figure 5-46. Completed Back Panel Assembly

5-54. PROCEDURAL INSTRUCTIONS  
 (Figures 5-47 through 5-49)

Some of the terms and procedures that are repeatedly called out in the Back Panel Assembly Instructions will be explained in detail in Paragraphs 5-55 through 5-58. (The experienced kit builder who is already familiar with these procedures may wish to skip to Paragraph 5-59.)

5-55. Terminal Ends. There are five different sizes of terminal ends used in the wiring of the back panel. The sizes are shown in Figure 5-47. Refer to this figure whenever a terminal end size is called out in the assembly instructions.

5-56. Wire Preparation. Before any wire is used in an assembly step, it should be prepared as follows:

1. Cut the desired length of wire.
2. Strip 1/8" to 1/4" of insulation off the ends.
3. Tin the exposed portion of the wire by applying a thin coat of solder.





| SIZE | BAG # | TERMINAL END  | WIRE GAUGE | SCREW SIZE |
|------|-------|---|------------|------------|
| A    | 2     |  | 12-10      | slip on    |
| B    | 2     |  | 22-18      | #6 screw   |
| C    | 2     |  | 12-10      | #6 screw   |
| D    | 2     |  | 12-10      | #10 screw  |
| E    | 2     |  | 12-10      | #10 screw  |

Figure 5-47. Terminal End Sizes



5-57. Attaching Terminal Ends to Wires. Most of the wire connections in the Back Panel Assembly Instructions call for attaching a terminal end to a wire and mounting it to the proper terminal. This procedure is detailed below:

For terminal end sizes A through D:

1. Insert the exposed portion of a wire that you have prepared into the correct size terminal end as shown in Figure 5-48.
2. Heat the wire and terminal end with a soldering iron. Apply solder to the heated wire, allowing the solder to flow until there is a solid solder connection.

**NOTE**

If the insulator on the terminal end loosens during soldering, be sure to push it all the way back in place when soldering is completed.

**NOTE**

Be sure to hold A size terminal ends vertically (with the wire down) while soldering to prevent solder flowing onto the slip-on tabs.

For terminal end size E:

Size E terminal ends do not have insulators, and therefore must be insulated with heat shrink tubing. The procedure for attaching E size terminal ends varies slightly, as follows:

1. Set the E size terminal end on the work surface and heat it with a soldering iron until it is hot enough to allow solder to flow.

2. Insert the exposed portion of a wire you have prepared into the terminal end and apply solder until there is a solid connection.
3. After the wire has been soldered in place and the joint has cooled, cut a 1-inch piece of heat shrink tubing and place it over the terminal end. Use a heat gun, if available, or a match to shrink the tubing.

**CAUTION**

Terminal ends become extremely hot during soldering. Allow five minutes cooling time after soldering before touching the terminal ends.

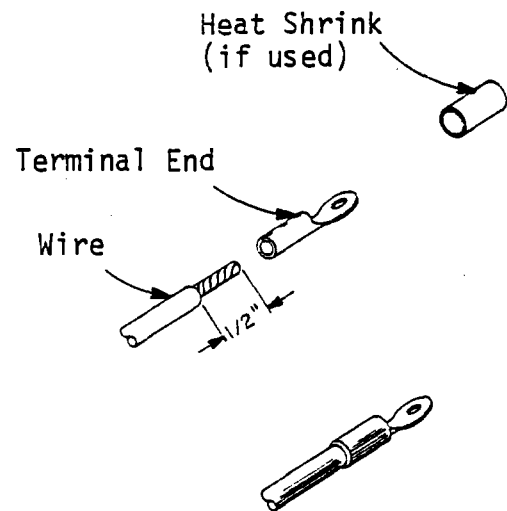

Figure 5-48. Terminal End Attachment

5-58. Connector Pins and Connector Sockets. Some of the wire connections in the back panel assembly instructions call for connector pins and connector sockets housed in a plastic plug. The general procedure for preparing these plug(s) is detailed below:

1. Insert the exposed portion of a wire that you have prepared into a connector pin or connector socket as shown in Figure 5-49A.
2. Crimp the lower portion of the pin or socket around the wire insulation. Solder the center portion of the pin or socket to the exposed portion of the wire.
3. Insert the pins and sockets into their respective housings as shown in Figure 5-49B.

4. Commoning tabs may be put into the pin housing over pins that must be shorted over together. Push the commoning tabs all the way to the base of the pin housing, using the tip of a small screwdriver.

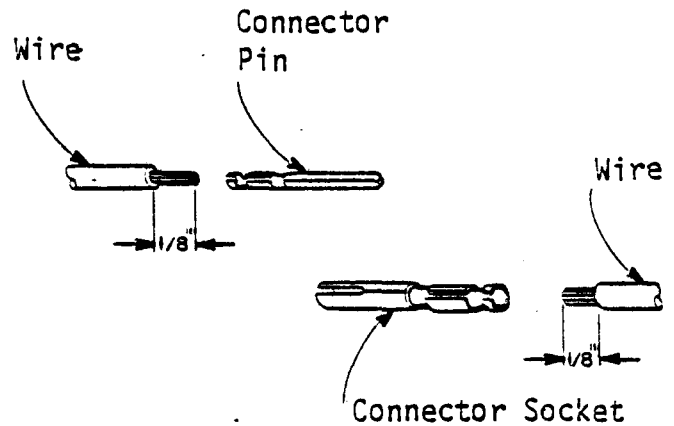

Figure 5-49A. Connector Pin and Connector Socket Wire Insertion

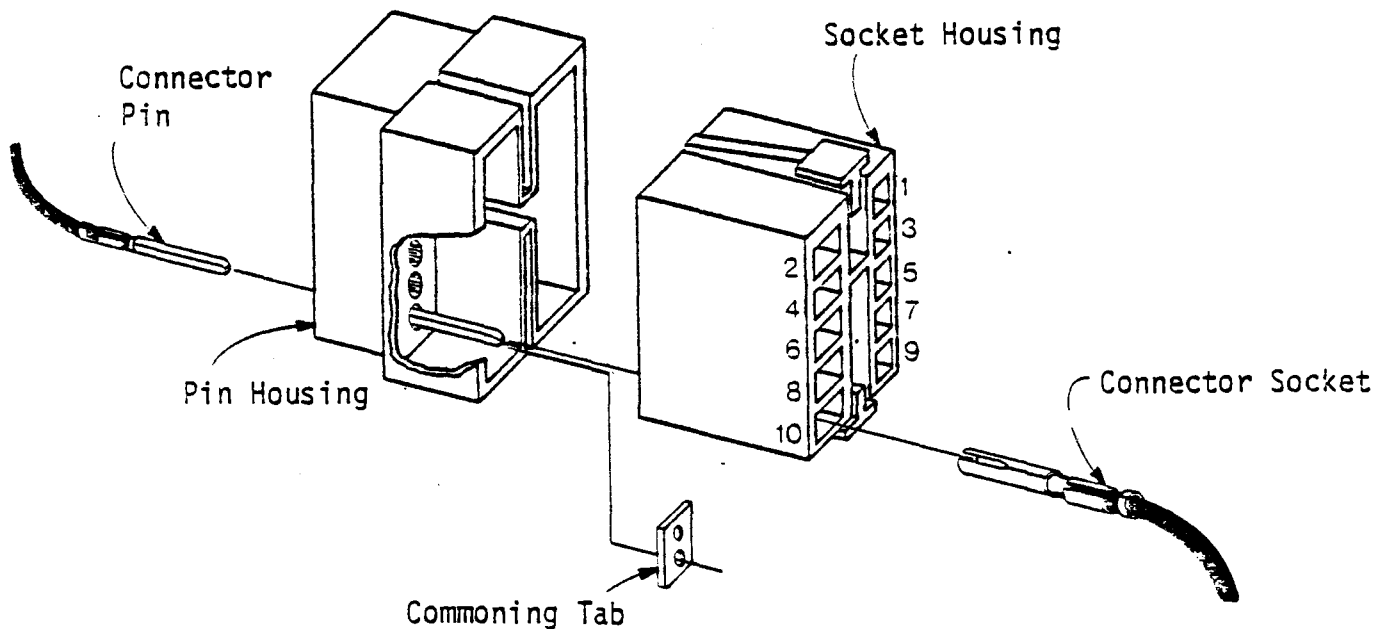

Figure 5-49B. Pin and Socket Housing Assembly

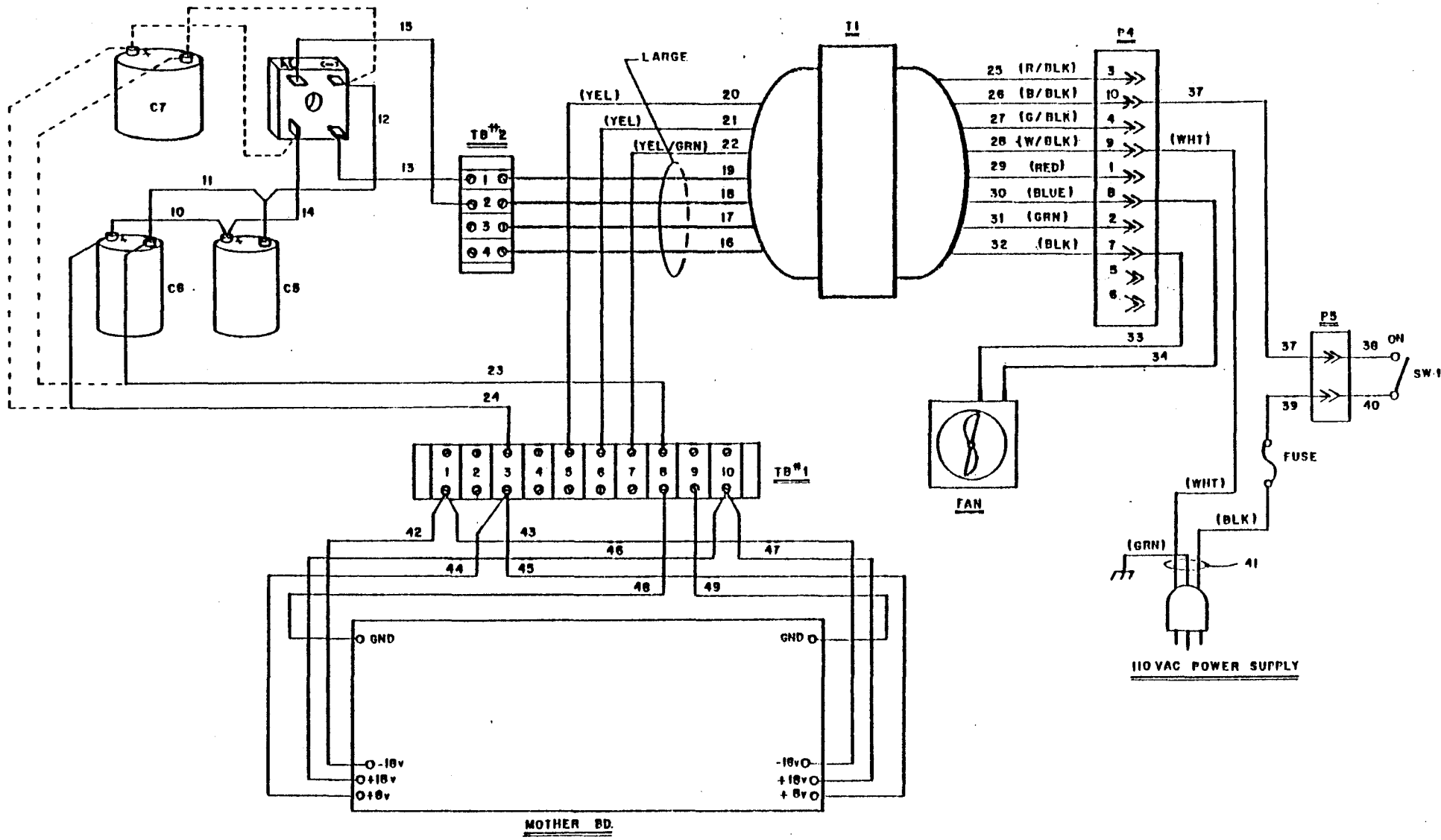

Figure 5-50. Wiring Diagram

5-59. CAPACITOR WIRING (Figure 5-50)

Before beginning assembly of the back panel, wire the capacitor or capacitors that are mounted on the Cross Member as follows:

Wiring For One Capacitor:

1. Cut two 9-inch lengths of 10-12 gauge wire. Attach C size terminal ends to one end of each wire. Attach D size terminal ends to the other end of each wire.
2. Connect the 9-inch wires to the capacitor by mounting the D size terminal ends to the "+" and ground terminals with the #10 screws provided.
3. Connect the wire from the "+" side of the capacitor to terminal #3 on the power supply board terminal block (TB1). (See wiring diagram, Figure 5-50.)
4. Connect the wire from the ground (-) side of the capacitor to terminal #8 of the terminal block (TB1). (See wiring diagram, Figure 5-50.)

Wiring For Two Capacitors:

1. Jumper the two "+" terminals to each other and the two ground terminals to each other with two 2-inch lengths of 10-12 gauge wire and four D size terminal ends.
2. Cut two 9-inch lengths of 10-12 gauge wire. Attach C size terminal ends to one end of each wire. Attach D size terminal ends to the other end of each wire.
3. Connect the 9-inch wires to C5 (capacitor closest to the Power Supply Board) by mounting the D size terminal ends to the "+" and ground terminals with the #10 screws.
4. Connect the wire from the "+" side of C5 to terminal #3 on the terminal block (TB1). (See wiring diagram, Figure 5-50.)
5. Connect the wire from the ground side of C5 to terminal #8 of the terminal block (TB1). (See wiring diagram, Figure 5-50.)

5-60. BRIDGE RECTIFIER INSTALLATION  
(Figure 5-51)

Use the following instructions to wire the bridge rectifier (Bag 1) and mount it to the back panel as shown in Figure 5-51. The bridge rectifier is part number KBH25005.

1. Mount the bridge rectifier to the back panel using a #6-32 x 3/4 inch screw, #6-32 nut, flat washer and lockwasher. Make sure the terminal labelled "-" is at the upper right corner.
2. Cut two 5-inch lengths of 12-10 gauge wire and two 19-inch lengths of 12-10 gauge wire.
3. Attach an A size terminal end to one end of each wire. Attach a D size terminal end to the other end of each wire.
4. Slip the A size terminal ends onto the bridge rectifier terminals as shown in Figure 5-51. Attach the two 5-inch wires to the "AC" terminals and use masking tape to label them 13 and 15. Attach the two 19-inch wires to the "+" and "-" terminals and label them 14 and 12 respectively.

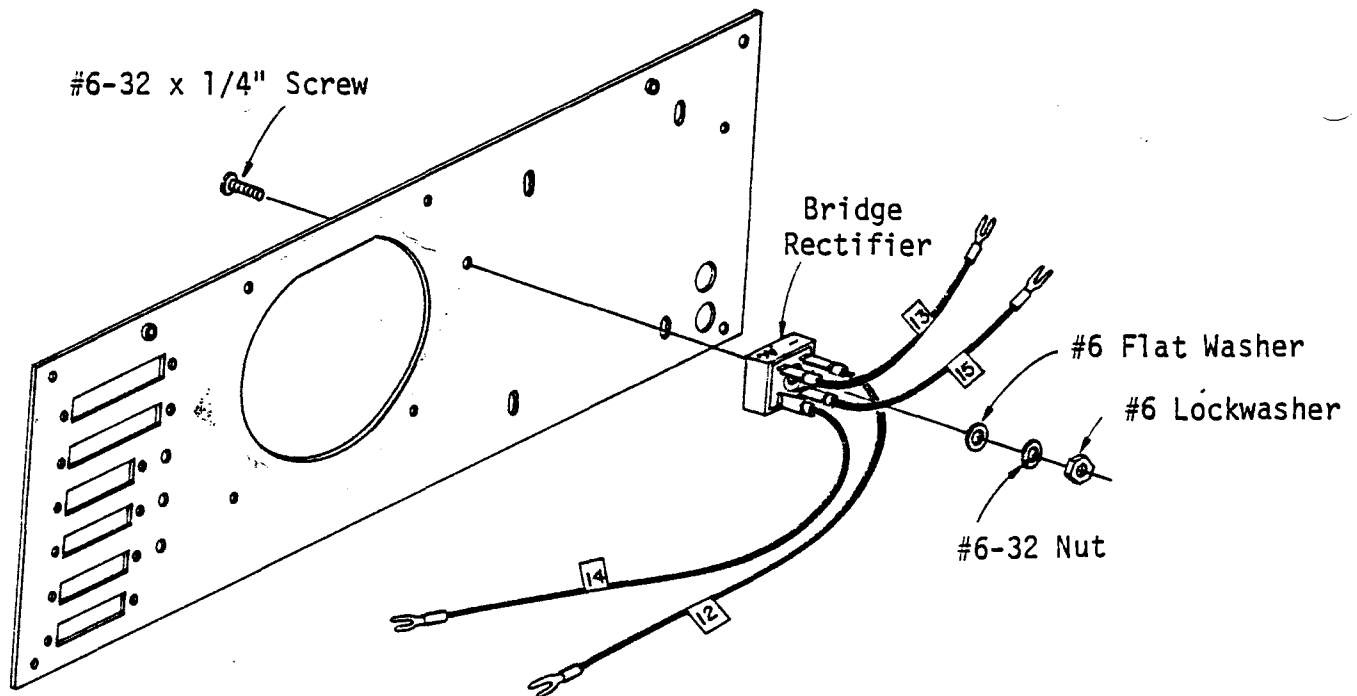

Figure 5-51. Bridge Rectifier Installation

5-61. FAN MOUNTING (Figure 5-52)

1. Before mounting the fan and fan screen to the back panel, install the female plug onto the terminals as shown in Figure 5-52. If your kit does not supply a plug, solder two 20-inch lengths of 22-18 gauge wire to the terminals.
2. Attach connector sockets (Paragraph 5-58) to the two wire ends. (The wire ends on the plug have been stripped and pre-tinned.) Label the wires 33 and 34.
3. Refer to Figure 5-52. Mount the fan screen and fan to the back panel (with the airflow flowing inward), using four #6-32 x 5/8 inch screws and four #6 "snap-on nuts."

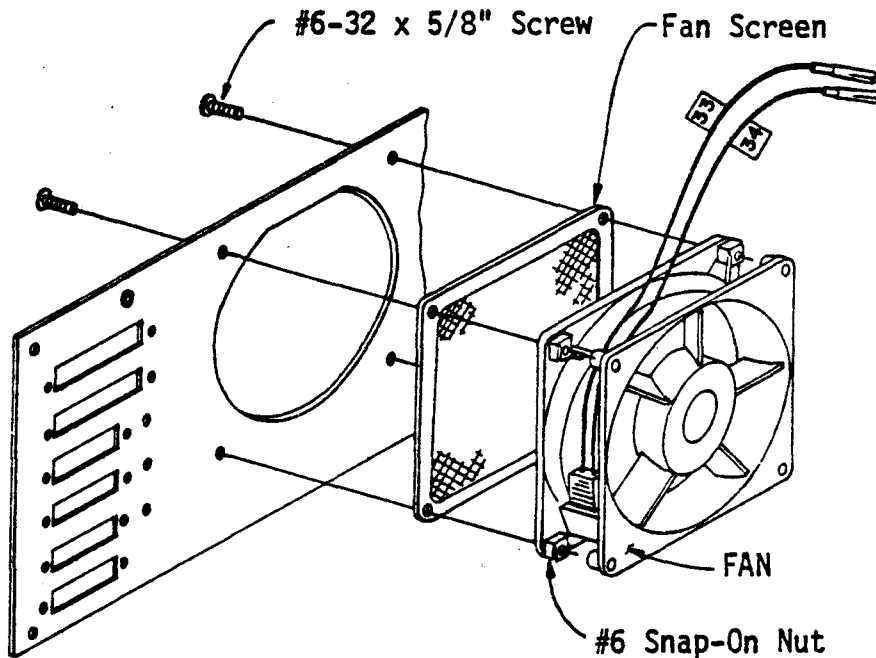

Figure 5-52. Fan and Fan Screen Mounting

5-62. FUSE AND FUSE HOLDER  
(Figure 5-53)

1. Secure the fuse holder (Bag 2) into the hole provided on the back panel using a fiber washer and mounting nut as shown in Figure 5-53.
2. Attach a 40-inch length of 22-18 gauge wire to the side terminal on the fuse. Mount a connector pin to the end of the 40-inch wire and label the wire #39 (see Paragraph 5-58).

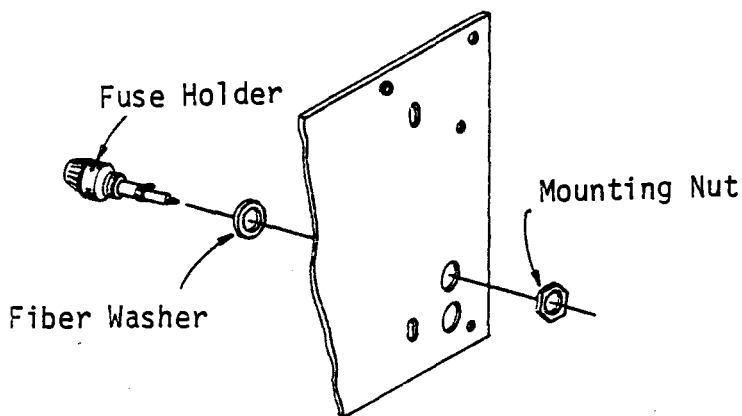

Figure 5-53. Fuse Holder Installation

5-63. AC POWER CORD (Figure 5-54)

1. Strip about 7 inches of casing off the end of the power cord to expose the three wires inside.
2. Put the strain relief (Bag 2) on the cord and position it as shown in Figure 5-54.
3. Snap the strain relief in place on the back panel.
4. Cut the black power cord wire to a length of 2 inches and solder it to the end of the fuse holder. Cut the green power cord wire to a length of 5 inches and attach a solder lug to the end. Attach a connector socket (Bag 4) (see Paragraph 5-58) to the end of the 7-inch white wire.

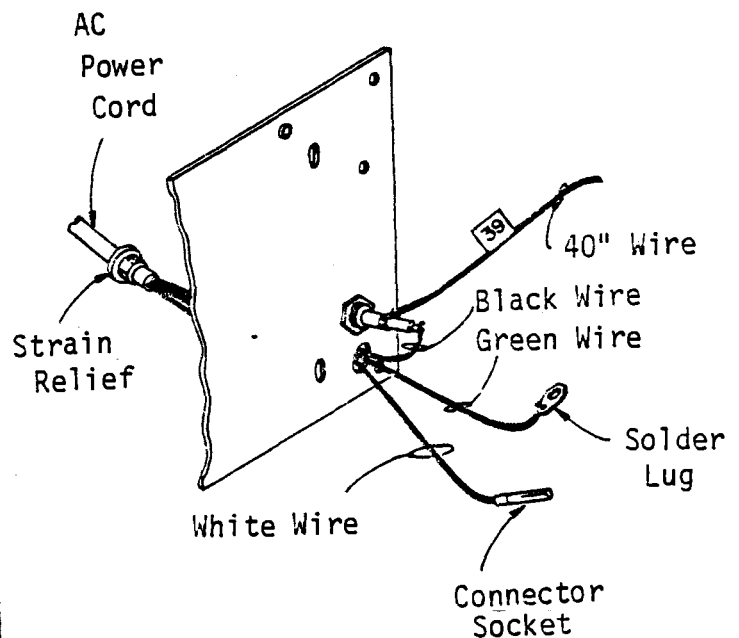

Figure 5-54. AC Power Cord Installation

5-64. TRANSFORMER (Figures 5-55 through 5-69)

The instructions for wiring and mounting the transformer will be divided into three parts: Secondary Wiring, Primary Wiring, and Transformer Mounting. Review Paragraphs 5-55 through 5-58 for the procedures involved.

5-65. Secondary Wiring.

1. Orient the transformer with the secondary side (four large wires) facing you. Remove the two top bolts and nuts and use them to mount two "L" brackets (Bag 2) as shown in Figure 5-55.
2. Attach an E size terminal end with heat shrink tubing (see Paragraph 5-58) to each of the four large transformer wires and label the wires 16-17-18-19 as shown in Figure 5-56.
3. Attach a B size terminal end to each of the three remaining secondary wires (Figure 5-56). Label the two yellow wires 20 and 21, and label the yellow/green wire 22.
4. Bend each of the E size terminal ends at a right angle as shown in Figure 5-56. Mount the four large wires to one side of the 4-terminal block (TB2), using the screws provided.
5. Mount the terminal block to the "L" brackets on the transformer using four #6-32 x 3/4 inch screws, four #6-32 nuts and four #6 lockwashers (Figure 5-57).

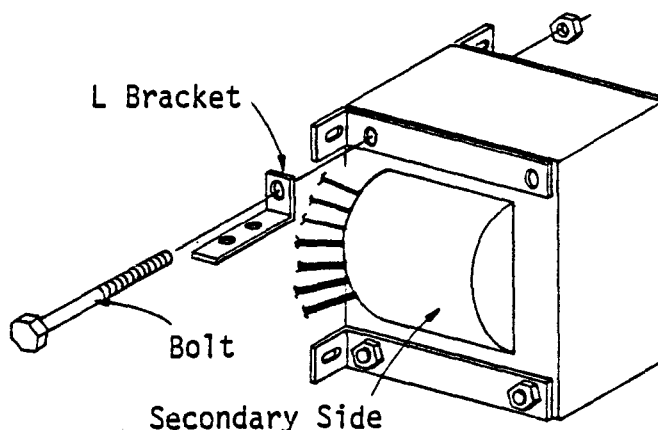

Figure 5-55. "L" Bracket Mounting

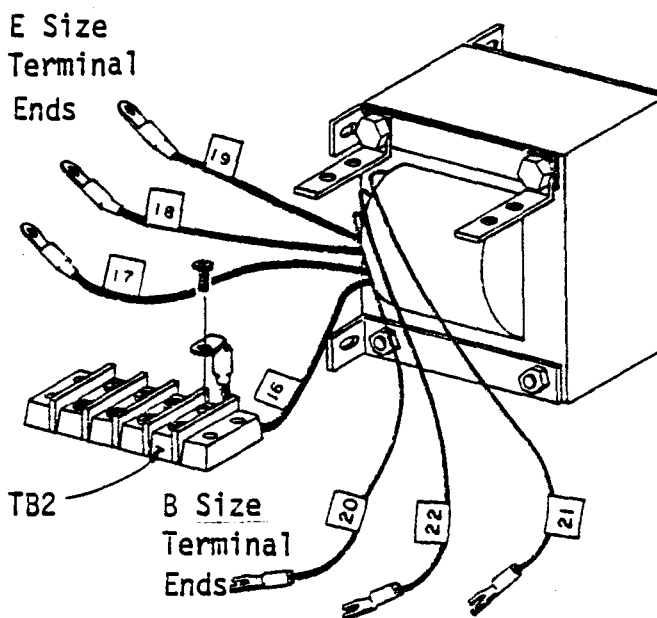

Figure 5-56. Terminal End Attachment

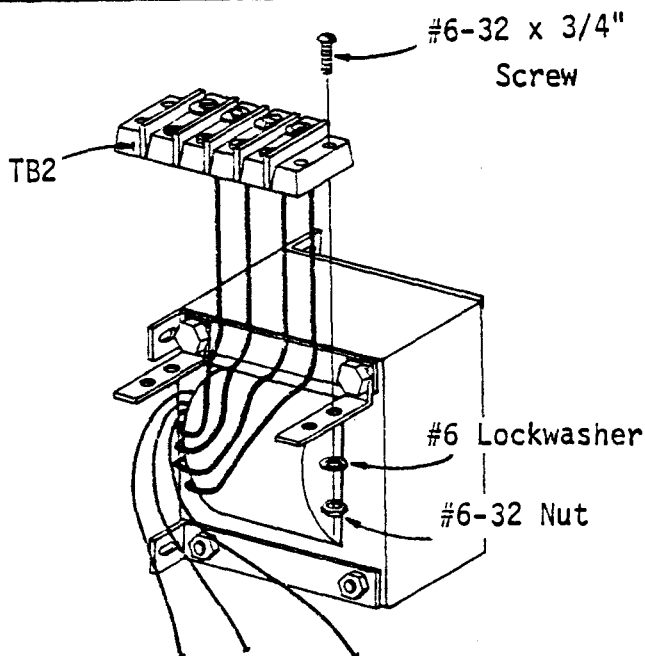

Figure 5-57. Terminal Block Mounting



5-66. Primary Wiring. The wires on the primary side of the transformer will be connected to the 110 volt source with a 10-pin plug (see Paragraph 5-58) according to the following instructions.

A. Pin Housing.

1. Attach a connector to each of the primary transformer wires.
2. When all eight wires on the primary side of the transformer have pins attached, insert the pin housing (P4) as shown in Figure 5-58. Insert the pins in the following order (see wiring diagram, Figure 5-50):

| Wiring Diagram Designation | Transformer Wire Color (Primary Side) | P4 Pin Housing Slot Number |
|----------------------------|---------------------------------------|----------------------------|
| 25                         | Red/Black                             | 3                          |
| 26                         | Blue/Black                            | 10                         |
| 27                         | Green/Black                           | 4                          |
| 28                         | White/Black                           | 9                          |
| 29                         | Red                                   | 1                          |
| 30                         | Blue                                  | 8                          |
| 31                         | Green                                 | 2                          |
| 32                         | Black                                 | 7                          |

Place a two-circuit commoning tab over the following pairs of pins:

2 and 4      1 and 3

7 and 9      8 and 10

Make sure the tabs do not come in contact with each other.

3. The two wires from the fan (33 and 34) are to be inserted into slots 7 and 8 of the P4 socket housing.

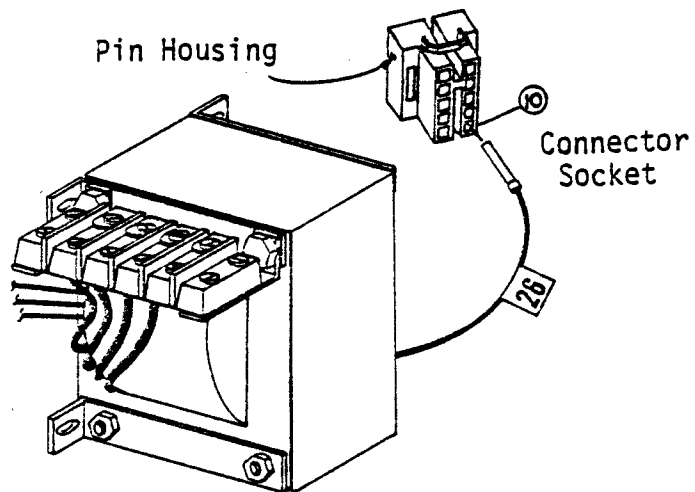

Figure 5-58. Pin Housing Insertion

B. Socket Housing.

1. Cut a 40-inch length of 22-18 gauge wire and attach a connector socket to each end. Label this wire 37.
2. Insert one connector socket of wire 37 into slot 9 of the 10-pin socket housing. Insert the socket on the 7-inch white AC power cord wire into slot 10 of the 10-pin socket housing.
3. Connect the socket housing to the pin housing, as shown in Figure 5-49.

5-67. Mount Transformer to Back Panel.

1. Mount the transformer to the back panel as shown in Figure 5-59 using four #10-32 x 1/2 inch screws, 4 nuts, 4 flat washers and four #10 lockwashers. (The transformer positioning may have to be adjusted later when the back panel is mounted to the mainframe, to insure the transformer is resting on the cross member.)
2. Attach wires 13 and 15 from the bridge rectifier to terminals 1 and 2 of the terminal block (TB2). (See Wiring Diagram, Figure 5-50.)

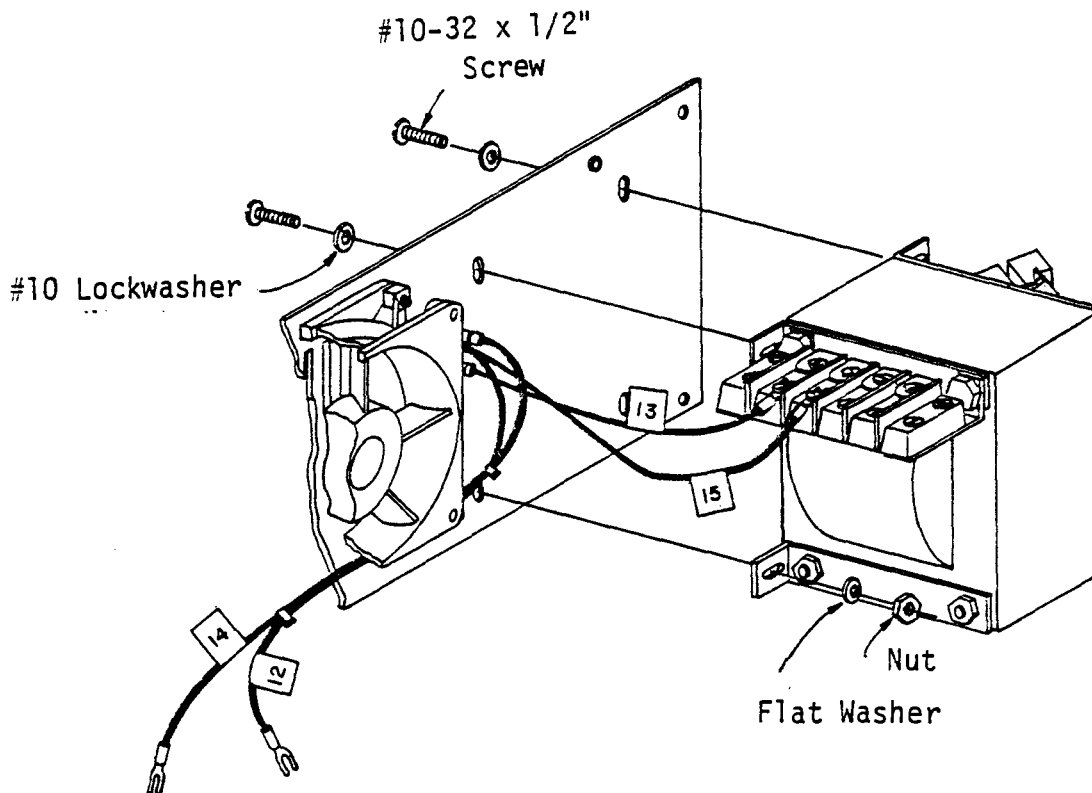

Figure 5-59. Transformer Mounting

5-68. MOUNT BACK PANEL TO MAINFRAME  
(Figure 5-60)

1. Mount the back panel to the mainframe as shown in Figure 5-60 using the original back panel mounting screws. (Tighten these screws down until they are just firm.)
2. Make sure the two 19-inch bridge rectifier wires, the 40-inch fuse wire (#39), and the 40-inch connector plug wire (#37) go under the fan as the back panel is mounted. Connect wire 14 from the bridge rectifier to the "+" side of the capacitor(s). Connect wire 12 from the bridge rectifier to the ground side of the capacitor(s). Make continuity checks (see wiring diagram, Figure 5-50).

NOTE

Make sure the wires from the fan go underneath the fan and the transformer as the back panel is mounted. Make sure the transformer rests solidly on the cross member when the back panel is in place.

3. Secure the solder lug on the green AC ground wire to one of the holes on the side of the mainframe using a #6-32 x 1/4" screw, a #6-32 nut, and a #6 lockwasher.
4. Connect three secondary wires from the transformer to Terminal Block #1 as follows:

Wire #20 (yellow) to slot #5, TB #1  
Wire #21 (yellow) to slot #6, TB #1  
Wire #22 (yellow/green) to slot #7, TB #1

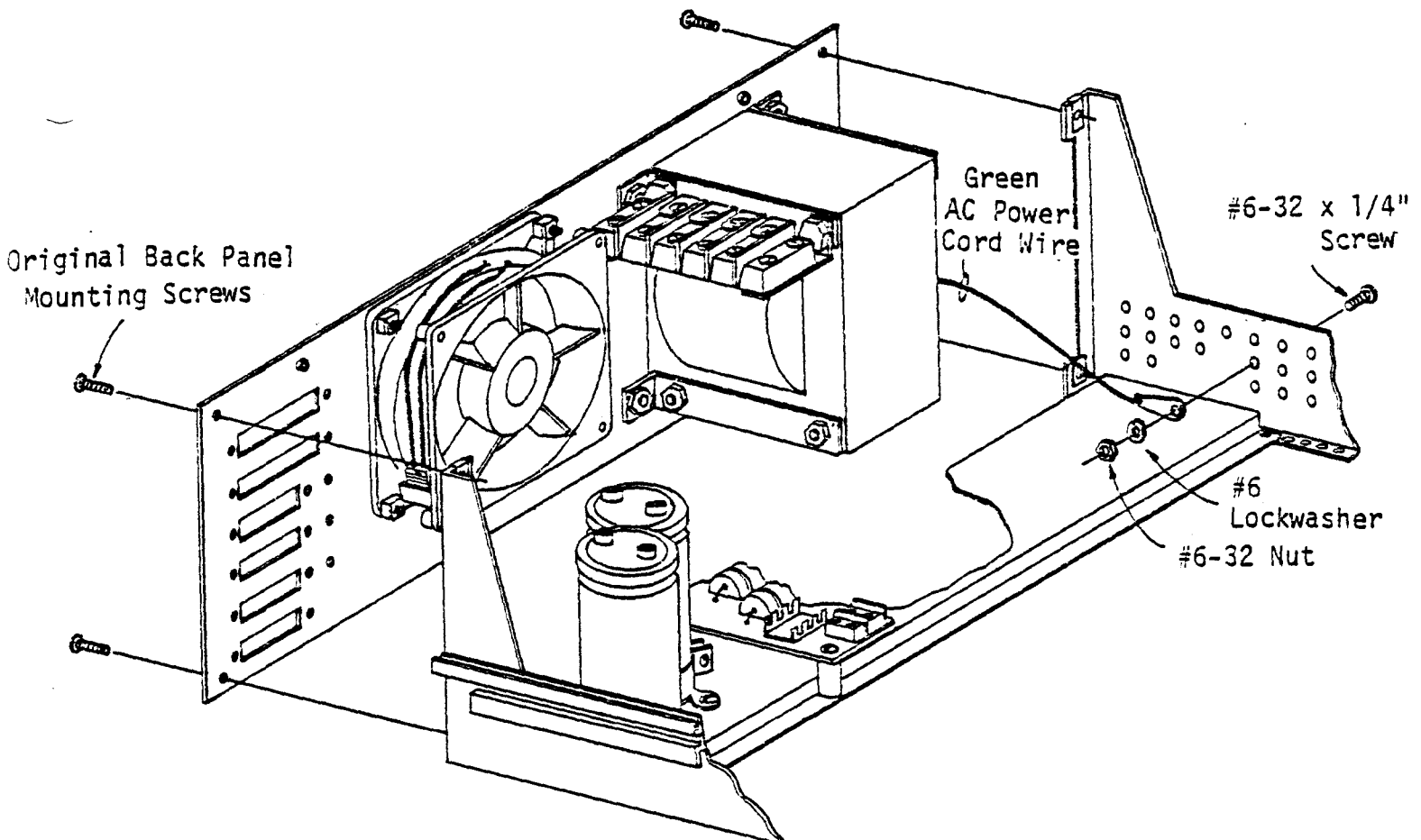

Figure 5-60. Back Panel Mounting

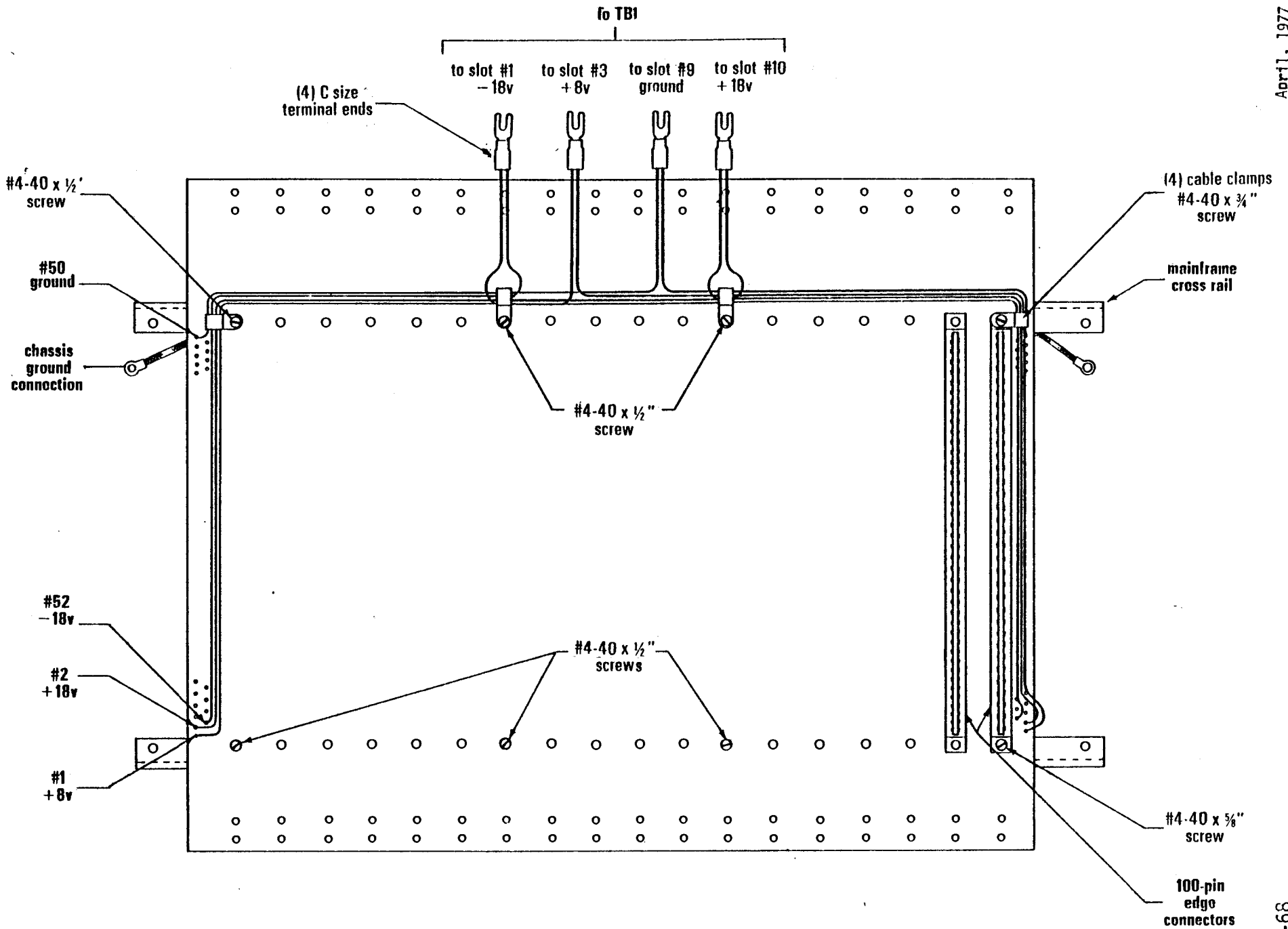

Figure 5-61. Motherboard Wire Connections

## 5-69. 18-SLOT MOTHERBOARD ASSEMBLY

### 5-70. BUS WIRE CONNECTIONS (Figure 5-61)

Refer to Figure 5-61. Note that the two outside rows of holes on either side of the motherboard each have four wire connections. These are the +8v, -18v, +18v and ground lines to the power supply from the bus. The wire connections are made by inserting the end of the wire from the top side of the motherboard and soldering it to the foil (bottom) side. On the foil side of the motherboard, hole #1 and hole #50 are marked on each side. Complete the wire connections according to the following instructions:

1. Cut six 20-inch lengths and two 14-inch lengths of 22-18 gauge wire.

On both sides of the motherboard:

2. Install one 20-inch wire into hole #1 (+8v).
3. Install one 20-inch wire into hole #2 (+18v).
4. Install one 20-inch wire into hole #52 (-18v).
5. Install one 14-inch wire into hole #50 (ground).

5-71. HARDWARE INSTALLATION  
(Figures 5-61 and 5-62)

At this time, the edge connectors, cable clamps, mainframe cross rails, and card guides will all be assembled onto the motherboard according to Figures 5-61 and 5-62 and the following instructions.

1. Position the two 100-pin edge connectors on the motherboard as shown in Figure 5-61. Carefully insert the connector pins into their respective holes. If necessary, guide some of the pins with the tip of a small screwdriver. Be sure that the connector is tight against the board and that all 100 pins have been inserted. Solder each connector pin to the foil pattern on the bottom of the board.
2. Visually inspect the connection to make sure there are no solder bridges.
3. Remove the two cross rails from the mainframe. Mount the cross rails to the bottom of the motherboard using eight screws, positioned as shown in Figure 5-61. Attach cable clamps to the four back mounting screws and run the bus wires through the cable clamps before tightening the screws down.
4. Match up the four pairs of bus wires at the back of the motherboard as shown in Figure 5-61. Attach a size C terminal end to each pair. Make sure the correct wires have been paired off:

-18v with -18v  
+8v with +8v  
ground with ground  
+18v with +18v

5. Mount the card guides on both sides of the connectors, as shown in Figure 5-62.

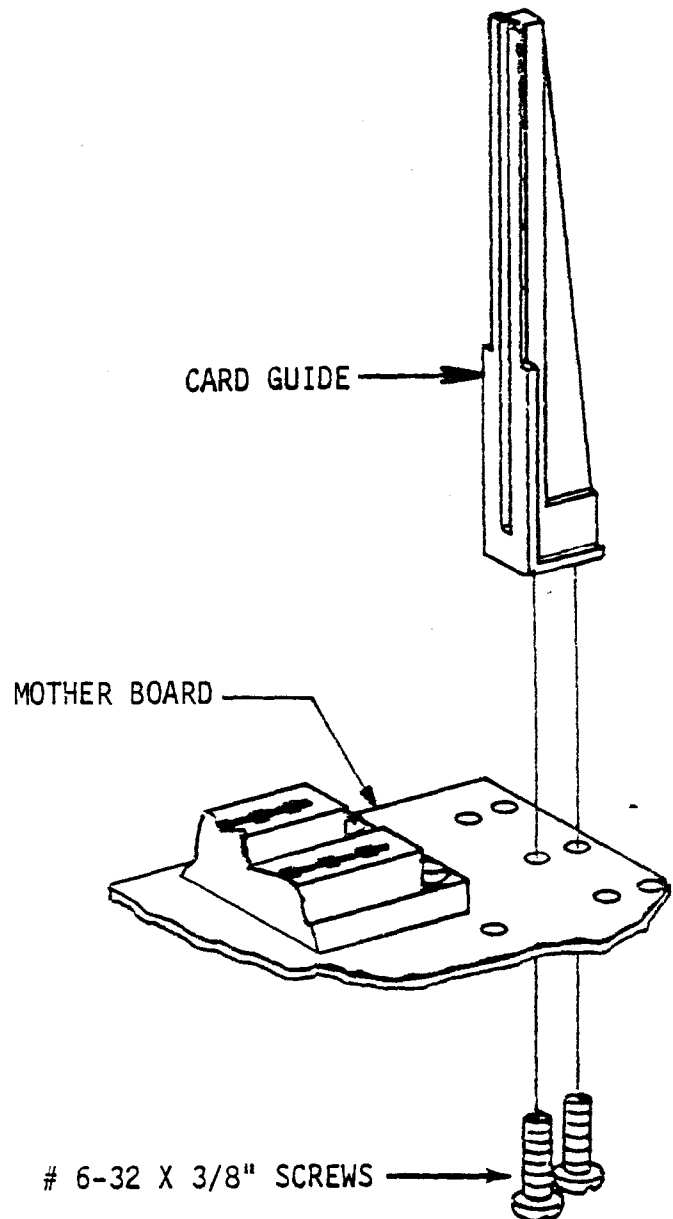

Figure 5-62. Card Guide Mounting

5-72. CHASSIS GROUND CONNECTION  
(Figure 5-63)

To insure a good ground connection between the motherboard and the chassis, two ground wires will be run from the ground land on the foil (bottom) side of the motherboard to the side rails of the mainframe. Refer to Figure 5-63 and make the ground connections according to the following instructions.

1. Cut two 6-inch pieces of wire braid.
2. Attach a solder lug to one end of each piece. To do this: twist the end of the wire braid; insert it into the small hole on the lug; solder the braid to the lug until the small hole is completely filled with solder.

On both sides of the motherboard:

3. Place the braid on the ground land along side the cross rail so that the lug and about three inches of braid hang over the side, as shown in Figure 5-63. Solder the remaining three inches to the ground land. It may be helpful to first "tack" the braid in place with small amounts of solder and then, using the flat of the soldering iron to heat the braid, make a solid solder connection over the entire three inches. Make sure there are no solder bridges to the adjacent lands on the board. The lugs will be attached to the side rails of the mainframe after the motherboard has been installed (Paragraph 5-73).

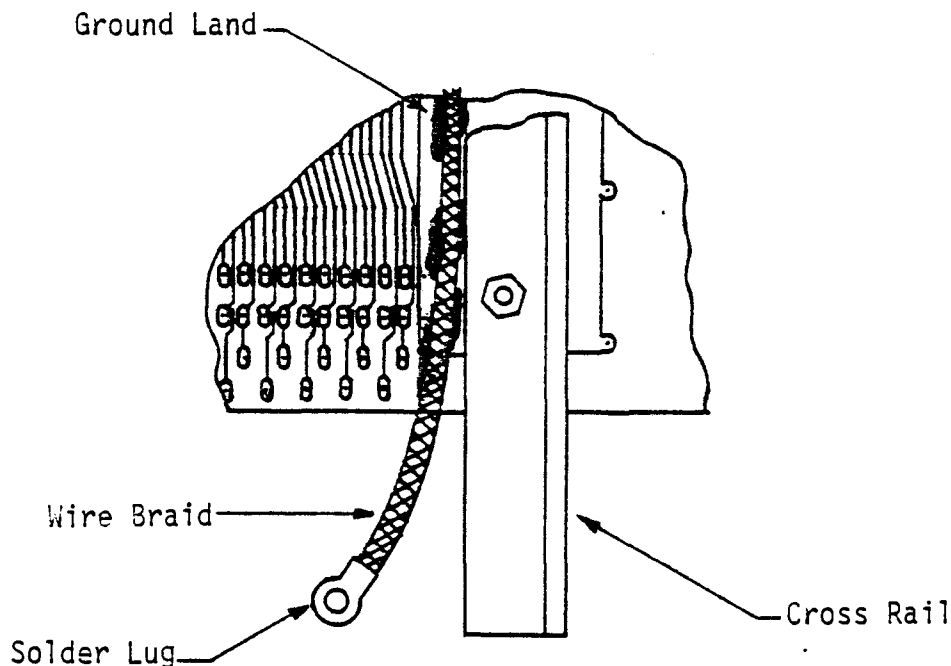

Figure 5-63. Chassis Ground Connection



5-73. INSTALL MOTHERBOARD ON MAIN-FRAME

1. Attach four #6-32 x 3/8" threaded spacers to the end holes in the crossrails, using #6-32 x 1/4" screws. Place the motherboard/crossrail assembly in the chassis so that the spacers at the front of the assembly align with the 8th hole (from the front) of the chassis side members. Secure the assembly to the chassis with four #6-32 x 1/4" screws.
2. Connect the four terminal ends on the bus wires to the terminal block (TBI) on the Power Supply Board as follows (see wiring diagram, Figure 5-50):

| Voltage | Bus Connection | TBI Connection |
|---------|----------------|----------------|
| -18v    | holes #52      | slot #1        |
| +8v     | holes #1       | slot #3        |
| ground  | holes #50      | slot #9        |
| +18v    | holes #2       | slot #10       |

Check for continuity between each bus connection and its respective terminal block connection.

3. To assure a good ground connection, rub the alodine coating off the chassis side member with steel wool. On each side of the board, connect the chassis ground wire from the motherboard to one of the holes on the chassis side member. Secure with a #6-32 x 3/8" screw and a #6-32 nut.

5-74. ON/OFF SWITCH WIRING  
(Figure 5-64)

The on/off switch (S1) on the Display/Control Board will connect to wires 37 and 39 from the power supply by means of a 2-pin plug, P5. (See wiring diagram, Figure 5-50.) Prepare the 2-pin plug (Bag 4) according to the following instructions. (Refer to Paragraph 5-58 for procedural instructions on preparing the connector sockets and pins.)

1. Cut two 2-inch pieces of 22-18 gauge wire.
2. Solder one wire (wire #40) to the center pin of S1 on the foil (bottom) side of the Display/Control Board. Solder the other wire (wire #38) to the bottom pin of S1.
3. Attach a connector pin to the free end of both wires. Insert the connector pins into the 2-pin pin housing, as shown in Figure 5-64.
4. Insert the connector sockets of wires 37 and 39 from the power supply into the 2-pin socket housing.

**CAUTION**

These sockets (37 and 39) will be directly connected to the 110v source: Make sure the sockets are completely enclosed inside the socket housing. It is advisable to use tape or heat shrink to insulate the wires where they enter the socket housing.

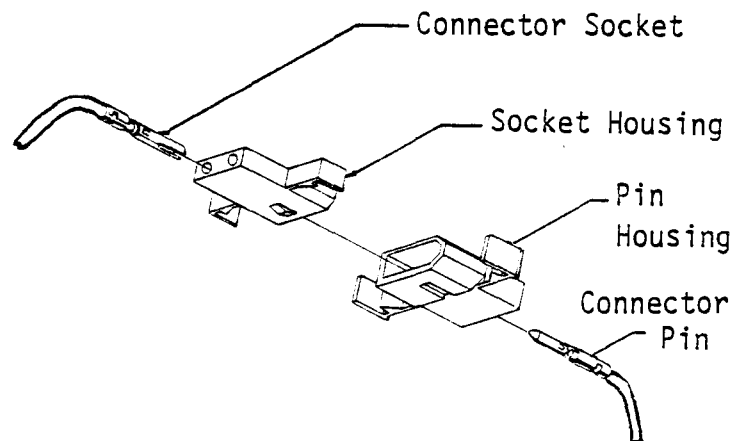
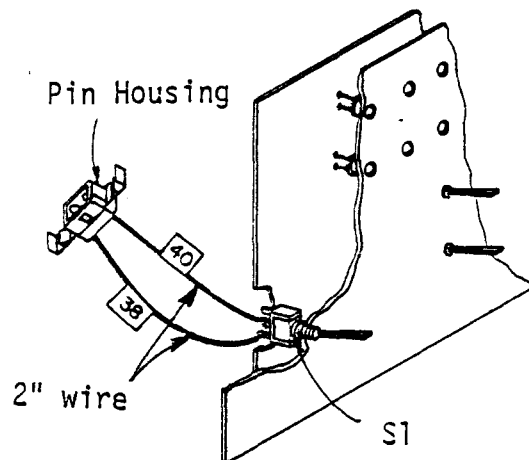

Figure 5-64. On/Off Switch Wiring

#### 5-75. MOUNT PC BOARDS IN MAINFRAME

1. Slide the Sub Panel (with the Display/Control Board attached) onto the front of the mainframe so that the front uprights are in between the Display/Control Board and the Sub Panel.
2. Secure the Sub Panel in place from the front of the mainframe using the four #6-32 flathead screws that came with the chassis. Pull the ground strap taut and secure to the chassis with a #6-32 x 1/4" screw and a #6-32 nut.
3. Perform a voltage check before installing the Interface Board and CPU Board. Connect the pin and socket housings of P5, put the fuse into the fuse holder, plug in the power cord, and turn S1 on. Monitor the voltages on the motherboard. If the voltages are not correct, refer to Section IV, Troubleshooting. (Disconnect power before proceeding with the next steps.)
4. Install the Interface Board onto the motherboard in the first (right-most) 100-pin connector. The ribbon connectors, P1 and P2 should be next to the Display/Control Board. Connect P1 and P2 from the Interface Board to P1 and P2 on the Display/Control Board.
5. Install the CPU Board into the next 100-pin connector. Prepare two female connectors (see Paragraph 5-76) and mount them so that P3 on the Interface Board is connected to P3 on the CPU Board.

5-76. Instructions for Female Connectors, P3 (Figure 5-65)

1. Using the wire in Bag 4 of the Interface Board, cut the wire into eight 2-inch lengths.
2. Strip 1/8 inch of insulation from the ends of each wire and tin the exposed ends by applying a thin coat of solder.
3. Install a connector pin (Bag 3 of D/C Interface Board) onto both ends of each wire by crimping the wire into place as shown in Figure 5-65 A and B. Then solder the exposed portion of the wire to the pin.
4. Insert the 8 pins into connector slots 3 through 10 on both connectors, as shown in Figure 5-65(C).
5. Insert the key (Bag 3 of D/C Interface Board) into connector slot #2. This key is inserted to insure that the female connectors are installed correctly.

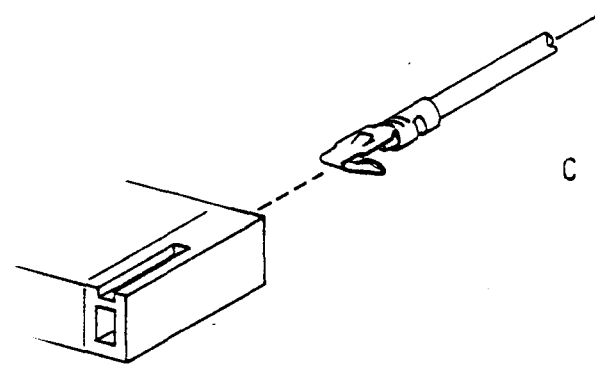
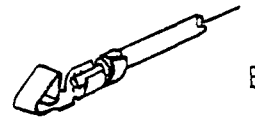
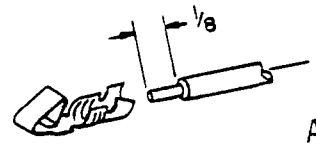

NOTE

Slot #1 will not be wired.

6. Aligning slot #1 with pin #1, install the female connector onto the male connector (P3) on the Interface Board and on the CPU Board.

Figure 5-65. Female Connector Wiring for P3

## 5-77. CASE

The dress panel included with your kit may curve slightly outward. If so, it should be flattened before mounting on the 8800b.

1. Look at the dress panel from the top edge to see the curve. Then hold the panel against the edge of a table and lightly run the palm of your hand down the length of the panel until it appears to be flat.
2. Snap the dress panel in place in front of the case bottom.
3. Lower the mainframe into the case bottom at a front-to-back angle, so the switches on the Display/Control Board fit through the holes on the dress panel.
4. Secure the mainframe in place on both sides by replacing the two original #6-32 x 3/8" mounting screws.
5. Put the case top on the case bottom.

**appendix**  
**A**

**parts list**

## 8800b Interface Board

| Bag | Quantity | Component                          | MITS Stock Number |
|-----|----------|------------------------------------|-------------------|
| 1   | 11       | 74LS04 Integrated Circuit          | 101042            |
|     | 3        | 74LS20 Integrated Circuit          | 101134            |
|     | 4        | 74367 Integrated Circuit           | 101040            |
|     | 1        | 7400 Integrated Circuit            | 101020            |
|     | 1        | 7402 Integrated Circuit            | 101021            |
|     | 1        | 7410 Integrated Circuit            | 101024            |
|     | 1        | 8212 Integrated Circuit            | 101071            |
|     | 1        | 7805 Voltage Regulator             | 101074            |
|     | 1        | 24-pin Socket                      | 102105            |
| 2   | 24       | .1 uf 12v Capacitor                | 100348            |
|     | 2        | 33 uf 16v Capacitor                | 100326            |
| 3   | 2        | Molex Key                          | 101791            |
|     | 3        | Ferrite Bead                       | 101876            |
|     | 1        | Heat Sink                          | 101870            |
|     | 1        | Small 10-pin Right Angle Connector | 101798            |
|     | 2        | Molex Plug                         | 101720            |
|     | 20       | Molex Terminal                     | 101723            |
|     | 5        | 6-32 x 3/8" Screw                  | 100925            |
|     | 2        | 4-40 x 5/8" Screw                  | 100904            |
|     | 1        | 6-32 Nut                           | 100933            |
|     | 2        | 4-40 Nut                           | 100932            |
|     | 1        | #6 Lockwasher                      | 100942            |
|     | 1        | #4 Lockwasher                      | 100941            |

8800b Interface Board - Continued

| Bag   | Quantity | Component                          | MITS Stock Number   |
|-------|----------|------------------------------------|---------------------|
| 4     | 1        | 100-pin Edge Connector             | 101864              |
|       | 2        | Card Guides                        | 101714              |
|       | 2        | Ribbon Cable Assembly 34 Conductor | 103038              |
|       | 4        | 14" Green or Blue Wire             | 103051 or<br>103052 |
| 5     | 7        | 2.2K 1/2w 5% Resistor              | 101945              |
| MISC. | 1        | PC Board                           | 100201              |



## 8800b Display Control Board

| Bag | Quantity | Component                  | MITS Stock Number |
|-----|----------|----------------------------|-------------------|
| 1   | 7        | 7407 Integrated Circuit    | 101142            |
|     | 5        | 7405 Integrated Circuit    | 101052            |
|     | 8        | 74LS175 Integrated Circuit | 101140            |
|     | 2        | 74LS74 Integrated Circuit  | 101088            |
|     | 1        | 74367 Integrated Circuit   | 101040            |
|     | 2        | 8T98 Integrated Circuit    | 101045            |
|     | 1        | 7493 Integrated Circuit    | 101030            |
|     | 2        | 7400 Integrated Circuit    | 101020            |
|     | 4        | 74LS04 Integrated Circuit  | 101042            |
|     | 1        | 74LS14 Integrated Circuit  | 101123            |
|     | 3        | 7410 Integrated Circuit    | 101024            |
|     | 1        | 74L10 Integrated Circuit   | 101081            |
|     | 2        | 74LS30 Integrated Circuit  | 101135            |
|     | 2        | 4040 Integrated Circuit    | 101130            |
|     | 1        | 4009 Integrated Circuit    | 101104            |
|     | 1        | 7805 Voltage Regulator     | 101074            |
|     | 1        | 79M08 Voltage Regulator    | 101111            |
| 2   | 2        | 100 Ohm 1/2w 5% Resistor   | 101924            |
|     | 1        | 470 Ohm 1/2w 5% Resistor   | 101927            |
|     | 1        | 1K 1/2w 5% Resistor        | 101928            |
|     | 1        | 4.7K Resistor Pack         | 101999            |
|     | 1        | 5 Ohm 5w 5% Resistor       | 102074            |
|     | 2        | 6-32 x 1/4" Screw          | 100917            |
|     | 2        | IN914 Diode                | 100705            |

8800b Display Control Board - Continued

| Bag   | Quantity | Component                 | MITS Stock Number |
|-------|----------|---------------------------|-------------------|
|       | 2        | 6-32 Nut                  | 100933            |
|       | 2        | #6 Lockwasher             | 100942            |
|       | 3        | Ferrite Beads             | 101876            |
| 3     | 37       | 220 Ohm 1/2w 5% Resistor  | 101925            |
| 4     | 34       | 2.2K Ohm 1/2w 5% Resistor | 101945            |
| 5     | 3        | .001uf 1kv Capacitor      | 100328            |
|       | 1        | .1uf 50v Capacitor        | 100380            |
|       | 2        | 47uf 16v Capacitor        | 100392            |
|       | 2        | 22uf 35v Capacitor        | 100393            |
| 6     | 25       | .1uf 12v Capacitor        | 100348            |
| 7     | 17       | SPDT (ST1-1F2C) Switch    | 101879            |
| 8     | 8        | MOM (ST1-3F2C) Switch     | 101880            |
| 9     | 36       | RL-21 LED                 | 100702            |
| 10    | 1        | 1702A Programmed PROM     |                   |
|       | 3        | 8212 Integrated Circuit   | 101071            |
|       | 4        | 24-pin Socket             | 102105            |
| MISC. | 1        | PC Board                  | 100200            |

## 8800b CPU Board

| Bag | Quantity | Component                 | MITS Stock Number |
|-----|----------|---------------------------|-------------------|
| 1   | 1        | 8080 Integrated Circuit   | 101070            |
|     | 1        | 8212 Integrated Circuit   | 101071            |
|     | 1        | 4009 Integrated Circuit   | 101143            |
|     | 1        | 24-pin Socket             | 102105            |
|     | 1        | 40-pin Socket             | 102106            |
| 2   | 2        | 8216 Integrated Circuit   | 101141            |
|     | 1        | 8224 Integrated Circuit   | 101125            |
|     | 7        | 74367 Integrated Circuit  | 101040            |
|     | 2        | 74368 Integrated Circuit  | 101045            |
|     | 2        | 74LS14 Integrated Circuit | 101123            |
|     | 1        | 74LS13 Integrated Circuit | 101124            |
|     | 2        | 74LS04 Integrated Circuit | 101042            |
|     | 1        | 7805 Voltage Regulator    | 101074            |
|     | 1        | 7812 Voltage Regulator    | 101085            |
| 3   | 24       | 2.2K 1/2w 5% Resistor     | 101945            |
| 4   | 13       | 3.3K 1/2w 5% Resistor     | 102085            |
|     | 1        | 15K 1/2w 5% Resistor      | 102083            |
|     | 1        | 1K 1/2w 5% Resistor       | 101928            |
|     | 1        | 620 Ohm 1/2w 5% Resistor  | 102095            |
|     | 1        | 330 Ohm 1/2w 5% Resistor  | 101926            |
|     | 2        | 470 Ohm 1/4w 5% Resistor  | 101902            |
|     | 1        | 10K 1/2w 5% Resistor      | 101932            |
|     | 1        | 100 Ohm 1/2w 5% Resistor  | 101949            |
|     | 1        | 10 Ohm 2w Resistor        | 101960            |

## 8800b CPU Board - Continued

| Bag   | Quantity | Component                          | MIT'S Stock Number |
|-------|----------|------------------------------------|--------------------|
|       | 1        | IN4733 5v Diode                    | 100721             |
|       | 1        | IN4730 3.9v Diode                  | 100734             |
|       | 3        | CS4410 or 2N4410 Transistor        | 102806             |
| 5     | 22       | .1uf 12v Capacitor                 | 100348             |
| 6     | 3        | .1uf 50v Capacitor                 | 100380             |
|       | 13       | 1uf 35v Capacitor                  | 100308             |
|       | 4        | 33uf 16v Capacitor                 | 100326             |
|       | 2        | 10uf 25v Capacitor                 | 100352             |
|       | 1        | 10uf 16v Capacitor                 | 100394             |
|       | 1        | 22uf 16v Capacitor                 | 100395             |
| 7     | 1        | Small 10-pin Right Angle Connector | 101798             |
|       | 1        | 100-pin Edge Connector             | 101864             |
|       | 2        | Card Guides                        | 101714             |
|       | 7        | Ferrite Beads                      | 101876             |
|       | 1        | 18 MHz Crystal                     | 101877             |
|       | 2        | Heat Sink (Large)                  | 101870             |
|       | 6        | 6-32 x 3/8" Screw                  | 100925             |
|       | 2        | 6-32 Nut                           | 100933             |
|       | 2        | #6 Lockwasher                      | 100942             |
|       | 2        | 4-40 x 5/8" Screw                  | 100904             |
|       | 2        | 4-40 Nut                           | 100932             |
|       | 2        | #4 Lockwasher                      | 100941             |
| MISC. | 1        | PC Board                           | 100198             |

## 8800b Power Supply Board

| Bag | Quantity | Component   | MITS Stock Number |
|-----|----------|---|-------------------|
| 1   | ✓ 1      | Bridge Rectifier 25 AMP, 50v (KBH25005)                         | 100735            |
|     | ✓ 1      | Bridge Rectifier TJ 118-0 (KBPC802)                             | 100733            |
|     | ✓ 1      | Transistor TIP 140, TIP 141<br>(with mica insulator and washer) | 102819            |
|     | ✓ 1      | Transistor TIP 145, TIP 146<br>(with mica insulator and washer) | 102820            |
|     | ✓ 2      | IN4746 18v Zener Diode  | 100726            |
|     | ✓ 2      | 180 Ohm 1/2w Resistor   | 101998            |
|     | ✓ 3      | Heat Sink (large)   | 101870            |
| 2   | ✓ 1      | Terminal Block 150 Series, 4 Term.                              | 101627            |
|     | ✓ 1      | Terminal Block 141 Series, 10 Term.                             | 101868            |
|     | ✓ 2      | Jumper for 141 Series   | 101651            |
|     | ✓ 1      | Fuse - 3 amp SLO-BLOW   | 101772            |
|     | ✓ 1      | Fuse Holder   | 101813            |
|     | ✓ 2      | T.B. Brackets   | 101652            |
|     | ✓ 1      | Strain Relief   | 101719            |
|     | ✓ 4      | Rubber Feet   | 101751            |
|     | ✓ 4      | Ring Terminal #10-#12 wire, #10 bolt                            | 101642            |
|     | ✓ 6      | Spade Terminal #10-#12 wire, #10 bolt                           | 101643            |
|     | ✓ 6      | Spade Terminal #10-#12 wire, #6 bolt                            | 101644            |
|     | ✓ 4      | Quik Disconnect #10-#12 wire, 1/4" tab                          | 101645            |
|     | ✓ 4      | Spade Terminal #18-#22 wire, #6 bolt                            | 101646            |
| 3   | ✓ 4      | 2200uf, 25v Capacitor   | 100375            |
| 4   | ✓ 1      | Plug MATE-N-LOK 10 Circuit                                      | 101635            |
|     | ✓ 1      | Receptacle MATE-N-LOK 10 Circuit                                | 101636            |
|     | ✓ 12     | Pin MATE-N-LOK  | 101639            |
|     | ✓ 12     | Socket MATE-N-LOK   | 101640            |

8800b Power Supply Board - Continued

| Bag | Quantity | Component                       | MITS Stock Number |
|-----|----------|---------------------------------|-------------------|
|     | 4        | Commoning Tab                   | 101641            |
|     | 1        | Plug MATE-N-LOK 2 Circuit       | 101637            |
|     | 1        | Receptacle MATE-N-LOK 2 Circuit | 101638            |
| 5   | 1        | 6-32 x 1/2" Screw               | 100918            |
|     | 19       | 6-32 x 3/8" Screw               | 100925            |
|     | 5        | 6-32 x 5/8" Screw               | 100916            |
|     | 9        | 6-32 x 9/16" Screw              | 100956            |
|     | 4        | 6-32 x 3/4" Screw               | 100935            |
|     | 1        | 8-32 x 1" Screw                 | 100927            |
|     | 4        | 10-32 x 1/2" Screw              | 100958            |
|     | 13       | 6-32 x 1/4" Screw               | 100917            |
|     | 19       | 6-32 Nut                        | 100933            |
|     | 4        | #6 Snap-On Nut (with fan)       | -----             |
|     | 1        | 8-32 Nut                        | 100929            |
|     | 4        | 10-32 Nut                       | 100962            |
|     | 2        | 6-32 x 3/8" Screw (Nylon)       | 100959            |
|     | 2        | 6-32 Nut (Nylon)                | 100960            |
|     | 17       | #6 Lockwasher                   | 100942            |
|     | 1        | #8 Lockwasher                   | 100945            |
|     | 4        | #10 Lockwasher                  | 100963            |
|     | 5        | 3/4" 6-32 Spacer (Threaded)     | 101626            |
|     | 4        | #6 Flat washer                  | 100943            |
|     | 1        | #8 Flat washer                  | 100939            |
|     | 4        | #10 Flat washer                 | 100961            |
|     | 4        | 3/8" 6-32 Threaded Spacer       | 101863            |

8800b Power Supply Board - Continued

| Bag             | Quantity | Component                 | MITS Stock Number |
|-----------------|----------|---------------------------|-------------------|
| MISC.           | 1        | 95000uf 15v DC with Clamp | 100391            |
|                 | 1        | PC Board                  | 100202            |
|                 | 1        | 6Ft. 3-wire Power Cord    | 101742            |
|                 | 1        | Fan                       | 101869            |
|                 | 20'      | #18 Stranded Wire         | 103090            |
|                 | 8'       | #12 Stranded Wire         | 103092            |
|                 | 2'       | Grn. Braid                | 101801            |
|                 | 4        | 3/16" Cable Clamps        | 103023            |
|                 | 20       | Tie Wrap                  | 103037            |
|                 | 6"       | Heat Shrink               | 103073            |
| Separate<br>Box | 1        | Transformer               | 102616            |

8800b Case and Misc.

| Quantity | Component                           | MITS Stock Number |
|----------|-------------------------------------|-------------------|
| 1        | Case                                | 100505            |
| 1        | Back Panel                          | 100545            |
| 1        | Dress Panel                         | 100541            |
| 1        | Main Board                          | 100193            |
| 2        | Card Rail                           | 101603            |
| 1        | Manual (Altair 8800b Documentation) | 101537            |





**mits**

2450 Alamo S.E.  
Albuquerque, New Mexico 87106

## USER'S DOCUMENTATION REPORT

In order to improve the quality and usefulness of our publications, user feedback is necessary. Your comments will help us effectively evaluate our documentation.

Please limit your remarks to the document, giving specific page and line references when appropriate. Specific hardware or software questions should be directed to the MITS Customer Service or Software Departments, respectively.

**NAME OF PUBLICATION:** \_\_\_\_\_

**SUGGESTIONS FOR IMPROVEMENT:** \_\_\_\_\_

\_\_\_\_\_  
\_\_\_\_\_  
\_\_\_\_\_

**ERRORS:** \_\_\_\_\_

\_\_\_\_\_  
\_\_\_\_\_  
\_\_\_\_\_

**Name** \_\_\_\_\_ **Date** \_\_\_\_\_

**Organization** \_\_\_\_\_

**Street** \_\_\_\_\_

**City** \_\_\_\_\_ **State** \_\_\_\_\_ **Zip** \_\_\_\_\_

-----  
**First Fold Here** -----

-----  
**Second Fold Here and Staple** -----

=====

No Postage Stamp  
Necessary If Mailed in  
the United States

**BUSINESS REPLY MAIL**

First Class Permit No. 2114, Albuquerque, New Mexico

Postage Will be Paid by:

**MITS, Inc.**  
2450 Alamo S.E.  
Albuquerque, New Mexico 87106

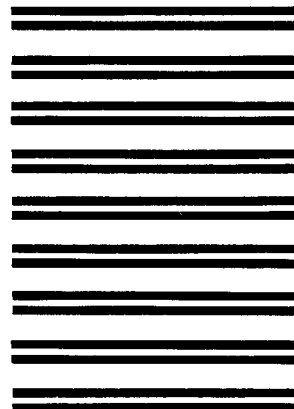

**mits**

2450 Alamo S.E. / Albuquerque, New Mexico 87106