

**4K DYNAMIC RAM
BOARD**

**ASSEMBLY
PROCEDURE**

MITS INC.

4K DYNAMIC RAM BOARD ASSEMBLY

Integrated Circuit Installation

There is a total of 28 integrated circuits (IC's) to be installed on the 8800 4K RAM Board (88-4MCD). The eight memory IC's will be installed later in the assembly procedure. The other 20 IC's should be installed at this time, according to the following procedure.

- (-) Referring to the component layout, remove the IC with the correct part number from its holder. If there are any bent pins, straighten these using needle-nose pliers. Ensure that you choose the IC with the correct part number.
- (-) Orient the IC so that its notched end corresponds with the notch printed on the board, and pin 1 of the IC corresponds with the arrowhead printed on the board.

NOTE: If the IC does not have a notch on one end, refer to the IC Orientation Chart included in your manual for the identification of pin 1.

- (✓) When you have the correct orientation, start the pins on one side of the IC into their respective holes on the silk-screened side of the PC Board. **DO NOT PUSH THE PINS IN ALL THE WAY.** If you have difficulty getting the pins into the holes, use the tip of a small screwdriver to guide them.

- (✓) Start the pins on the other side of the IC into their respective holes in the same manner. When all of the pins have been started, set the IC into place by gently rocking it back and forth until it rests as close as possible to the board. Make sure that the IC is perfectly straight and as close to the board as possible; then tape it in place with a piece of masking tape.
- (.) Turn the board over and solder each pin of the IC to the foil pattern on the back side of the board. Be sure to solder each pin and be careful not to leave any solder bridges.
- (.) Turn the board over again and remove the piece of masking tape.

Use the same procedure to install each of the IC's. Be sure that you have the correct part number and the correct orientation as you install each one.

- () IC's A, B & R are 74LS04's
- (✓) IC D is a 74193
- (✓) IC's F & E are 74L193's
- (✓) IC's G & T are 7473's
- (✓) IC's H & I are AM26L123's
- (✓) IC J is a 74L20

- (✓) IC M is a 74L02
- () IC N is an 8212
- (✓) IC's O, P, Q & S are 8T97's
- (✓) IC's L & K are 74L00's
- (✓) IC Z is a 7406

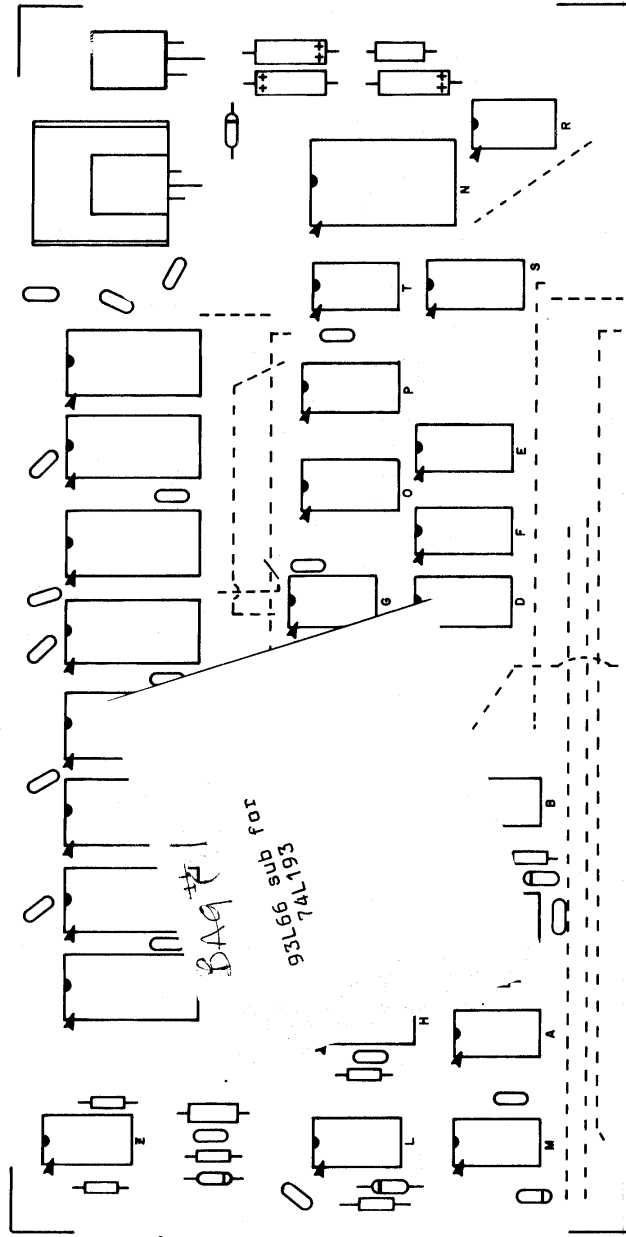

Resistor Installation

There are 11 resistors to be installed on the 8800 4K RAM Board.

NOTE: Resistors are color coded according to their value. The resistors in your kit will have four or possibly five bands of color. The fourth band in both cases will be gold or silver, indicating the tolerance. In the following instructions we will be concerned only with the three bands of color to one side of the gold or silver band. Be sure to match these three bands of color with those called for in the instructions as you install each resistor.

Using needle-nose pliers, bend the leads of the following resistors at right angles to match their respective holes on the PC board. (see component layout)

NOTE: All resistors on the 4K RAM Board may be either 1/4 or 1/2 Watt; except resistor R9, which must be 1/2 Watt.

- (.) Install resistor R1 (100-ohm, brown-black-brown) into the correct holes on the silk-screened side of the PC board.
- (.) Holding the resistor in place with one hand, turn the board over and bend the two leads slightly outward.
- (.) Solder the leads to the foil pattern on the back side of the board; then clip off any excess lead lengths.

Referring to the component layout, install the remaining resistors in the same manner. Be sure you have the correct color-coding for each one as you install them.

NOTE: Save the component leads that you clip off for use later in the assembly procedure.

- (-) R11 is 100-ohms, brown-black-brown
- (-) R2, R7 & R8 are 1K-ohms, brown-black-red
- (-) R3 is 22K-ohms, red-red-orange
- (-) R4 is 27K-ohms, red-violet-orange
- (-) R5 is 20K-ohms, red-orange
- (-) R6 is 43K-ohms, yellow-orange-orange
- (-) R9 & R10 are 470-ohms, yellow-violet-brown

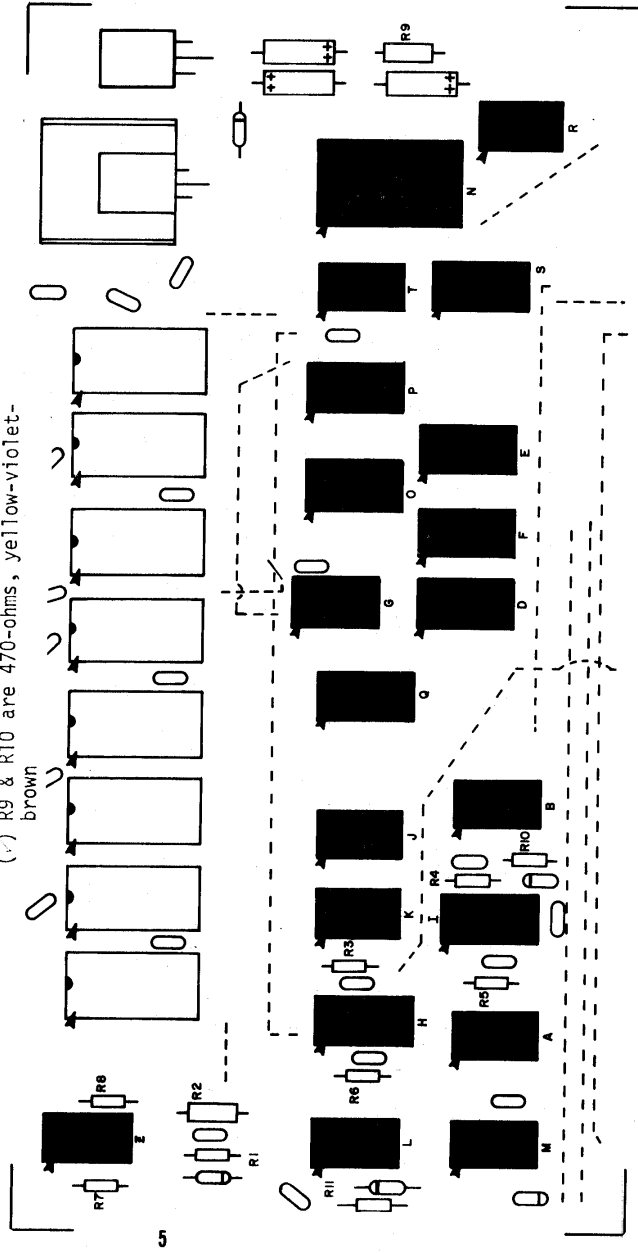

Capacitor Installation

There are 21 ceramic disk capacitors and 3 electrolytic capacitors to be installed on the 8800 4K RAM Board.

Refer to the component layout and install the ceramic disk capacitors according to the following procedure.

- (✓) Choose the capacitor with the correct value as called for in the instructions. Straighten the two leads as necessary and bend them to fit their respective holes on the PC board.
- (.) Insert the capacitor into the correct holes from the silk-screened side of the board. Push the capacitor down until the ceramic insulation almost touches the foil pattern.
- (.) Holding the capacitor in place, turn the board over and bend the two leads slightly outward.
- (.) Solder the two leads to the foil pattern on the back side of the board; then clip off any excess lead lengths.

Install all of the ceramic disk capacitors in this manner. Be sure that you have the correct value capacitor as you install each one.

The three electrolytic capacitors for the 4K RAM Board have polarity requirements which must be noted before installation. Those contained in your kit may have one or possibly two of three types of polarity markings. To determine the correct orientation, look for the following: (see drawing above right)

(✓) Add 21 disk cap

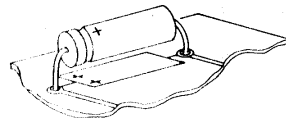

ELECTROLYTIC
CAPACITOR

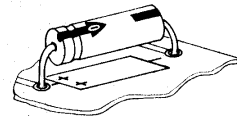

One type will have plus (+) signs on the positive end; another will have a band or a groove around the positive side in addition to the plus signs. The third type will have an arrow on it; in the tip of the arrow there is a negative (-) sign and the capacitor must be oriented so the arrow points to the negative polarity side.

Referring to the component layout, install the electrolytic capacitors on the board.

- (.) Bend the two leads of the capacitor with the correct value at right angles to match their respective holes on the board. Insert the capacitor into the holes on the silk-screened side of the board. Be sure to align the positive polarity side with the "+" signs printed on the board.
- (.) Holding the capacitor in place, turn the board over and bend the two leads slightly outward. Solder the leads to the foil pattern and clip off any excess lead lengths.
- (.) Install the remaining electrolytic capacitors in the same manner.

- (✓) C1 & C22 are .001uf
- (✓) C2 is 470pf
- (-) C3 & C5 are 20pf
- (✓) C4 is 100pf
- (-) C6, C7 & C8 are 35uf
- (-) C9 through C17, C19 through C21, and C23 & C24 are .1uf
- (✓) C18 is 220pf

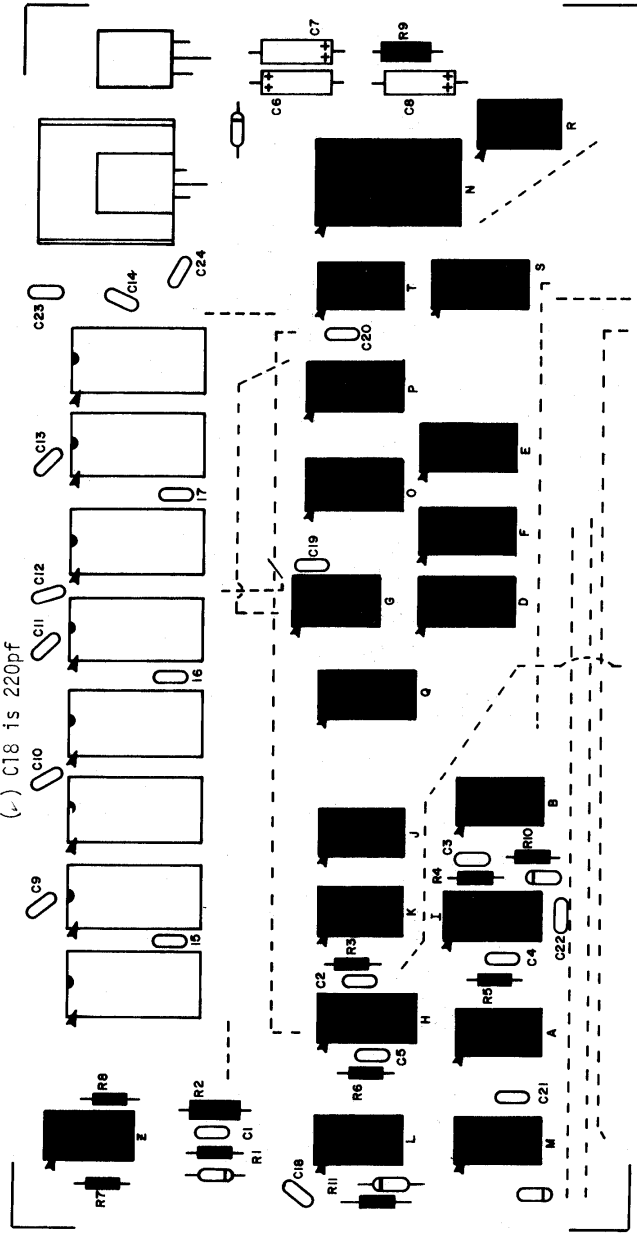

Transistor Installation

There is 1 PNP, EN2907 transistor to be installed on the 8800 4K RAM Board.

NOTE: When installing this transistor, ensure that you check the part number before soldering it into place. Some transistors are identical in physical appearance but differ in electrical characteristics. If the part number on the transistor does not match the number called for in the instructions, it may be that you have substitutions. In this case refer to the Transistor Identification Chart included with your manual.

- (✓) This transistor is rounded and has a flat edge near one of the leads. The lead nearest this flat edge is called the emitter. The hole for the emitter is marked with an "E" on the board, next to the transistor Q1 designation. If the emitter lead is placed into this hole, the other two leads should fit into their holes with little or no bending and should not cross over each other. (see drawing below)

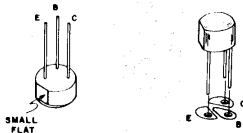

- (.) Orient Q1 so that the lead nearest the flat edge aligns with the correct hole on the board. Insert the transistor into the holes from the silk-screened side of the board.
- () Holding the transistor in place, turn the board over and bend the three leads slightly outward.
- (.) Solder the leads to the foil pattern on the back side of the board; then clip off any excess lead lengths.

Diode Installation

There are four 1N914 diodes and one 3.3v (1N746A) zener diode to be installed on the 8800 4K RAM Board.

NOTE: Diodes are marked with a band on one end indicating the cathode end. The diode must be oriented so that the end with the band is towards the band printed on the board when being installed.

- () Referring to the component layout, bend the leads of diode D1 (1N914) at right angles to match the correct holes on the board.
- () Insert the diode into the correct holes from the silk-screened side of the board. Turn the board over and bend the two leads slightly outward.
- () Solder the leads to the foil pattern on the back side of the board; then clip off any excess lead lengths.

Install zener diode D2 and the remaining 1N914 diodes, D3, D4 & D5, in the same manner. Be sure that the band on the diode is aligned with the band printed on the board as you install them. Failure to orient these diodes correctly may result in permanent damage to your unit.

D2 1N746A 3.3V ZENER
D3 1N914
D4 1N914
D5 1N914

(.) Q1 is an EN2907

(-) D1, D3, D4 & D5 are 1N914's

(.) D2 is a 1N746A

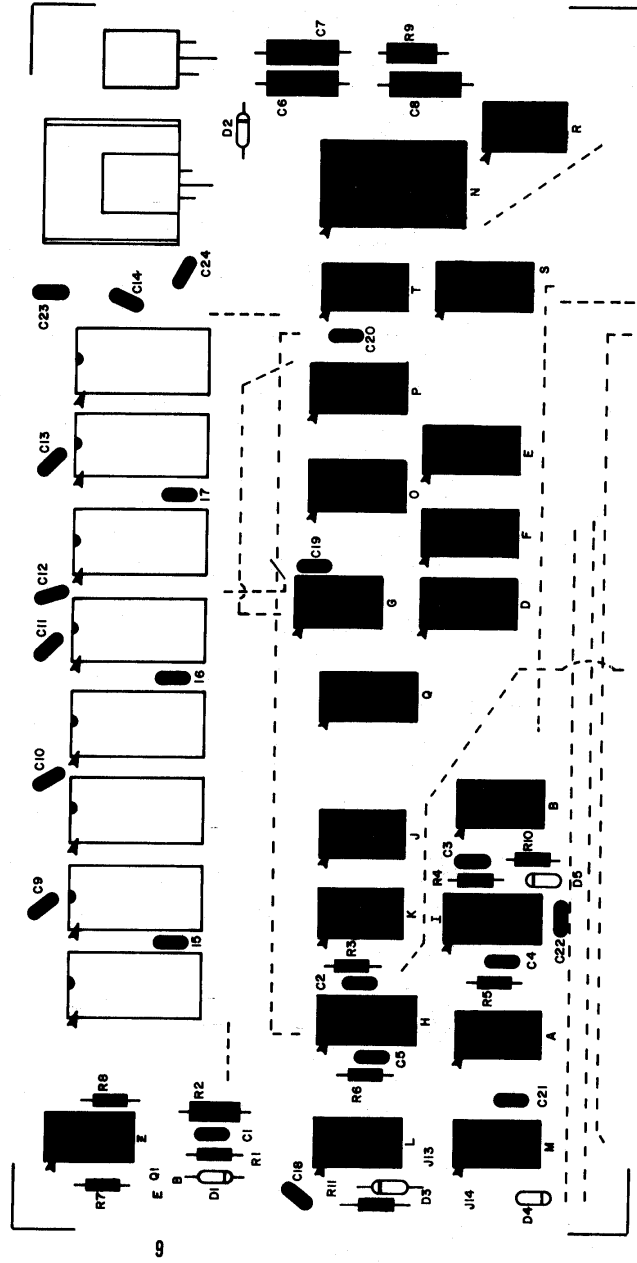

PC Jumper Wire Connections

There are 17 hardwire jumper connections to be made on the 8800 4K RAM Board.

These jumpers are indicated on the PC board in two manners. The first twelve are indicated by the two pads to be connected having the same designation and shown connected by a broken line printed on the board. The remaining five are indicated simply by the two pads to be connected having the same designation.

Cut the wire for each jumper to the correct length for each connection allowing an extra 1/2 inch. Strip 1/4 inch of insulation from both ends of each wire and tin them by applying a thin coat of solder to the uninsulated portion.

NOTE: It is very important for the operational performance of this board to keep the length of these jumper wires as short as possible. Any excess wire lengths may create "noise" and influence critical timing operations.

Make each of the following connections by inserting the wires from the silk-screened side of the board and soldering them to the foil pattern on the back side. Be sure to clip off any excess lead lengths as you install each jumper.

NOTE: Jumpers J1, J7, J8 & J12 should be made using the heavier gauge wire included with your kit.

- () Connect J1 to J1 *heavy*
- () Connect J2 to J2
- () Connect J3 to J3
- () Connect J4 to J4
- () Connect J5 to J5
- () Connect J6 to J6
- () Connect J7 to J7 *heavy*
- () Connect J8 to J8 *heavy*
- () Connect J9 to J9
- () Connect J10 to J10
- () Connect J11 to J11
- () Connect J12 to J12 *heavy*
- () Connect J13 to J13
- () Connect J14 to J14
- () Connect +7v to +7v
- () Connect -15v to -15v
- () Connect +15v to +15v

(-) Install all 17 jumpers as per the instructions.

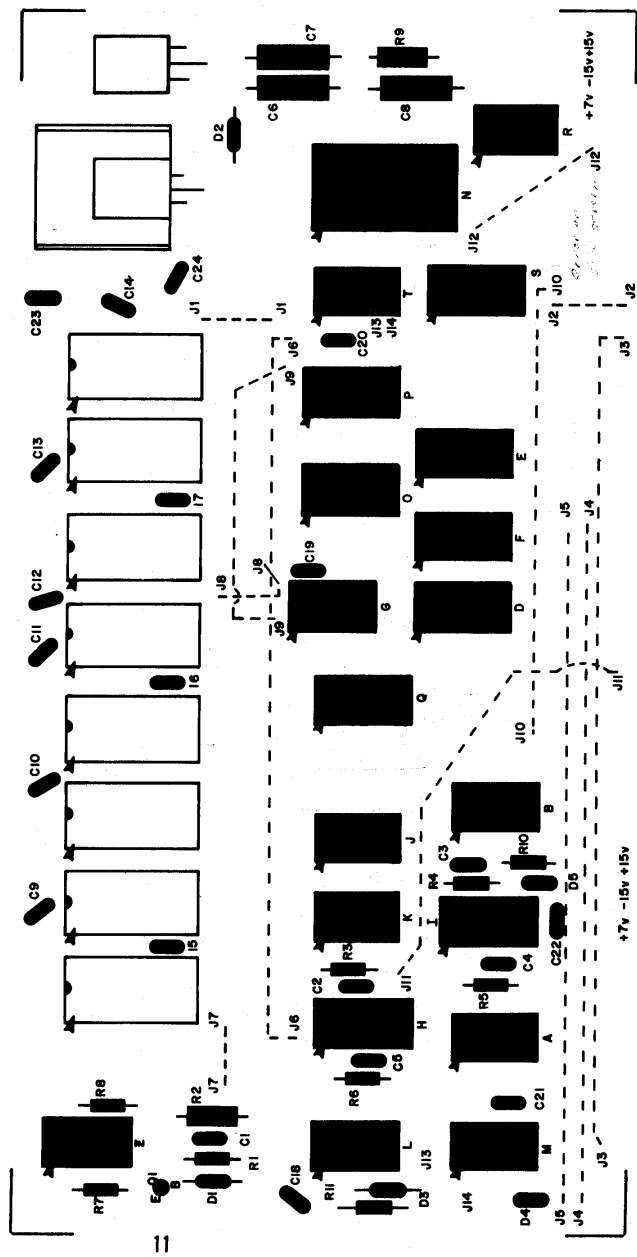

Voltage Regulator Installation

There is one 7805 5-volt regulator and one 7812 12-volt regulator to be installed on the 8800 4K RAM Board.

- (.) Set the 7805 (VR5) in place on the board and align the mounting holes. (see drawing)
- (.) Use a pencil to mark the point on each of the three leads where they line up with their respective holes on the board.
- (.) Use needle-nose pliers to bend each of the three leads at a right angle on the points where you made the pencil marks.

NOTE: Use heat-sink grease when installing these components. Apply the grease to all surfaces which come in contact with each other.

- (.) Referring to the drawing, set the regulator and heat sink in place on the silk-screened side of the board. Secure them as shown, holding the regulator in place as you tighten the nut to keep from twisting the leads.
- (.) Turn the board over and solder the three leads to the foil pattern on the back side of the board. Be sure not to leave any solder bridges.
- (.) Clip off any excess lead lengths.
- (.) Install the 7812 (VR12) in the same manner; except there is no heat sink to be installed with this regulator.

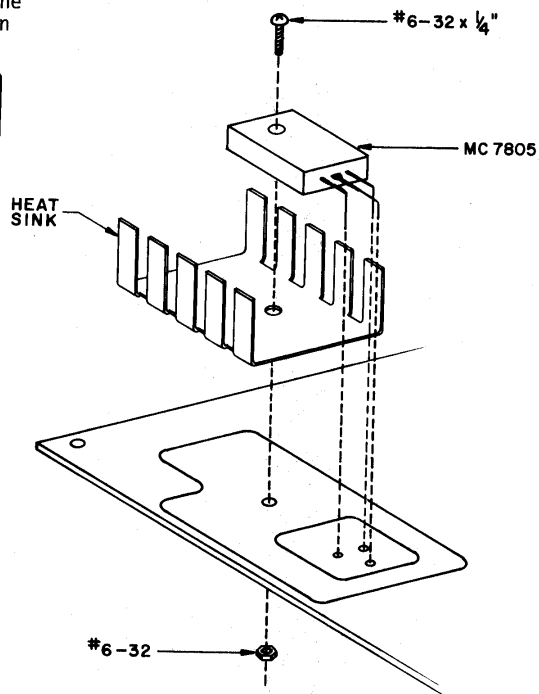
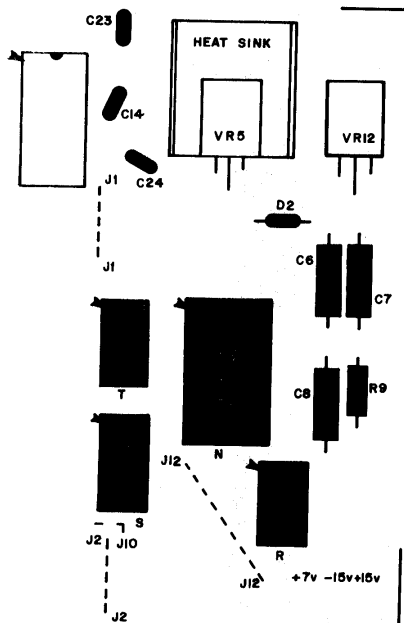

MOS Integrated Circuit Installation

There are eight MOS Integrated Circuits (IC's) to be installed on the 8800 4K RAM Board.

These IC's are very sensitive to static electricity and transient voltages. In order to prevent damage to these components review the information contained in the MOS IC SPECIAL HANDLING PRECAUTIONS included with your manual.

- (-) Referring to the component layout, remove the IC with the correct part number from its holder. If there are any bent pins, straighten these using needle-nose pliers. Ensure that you choose the IC with the correct part number.
- (-) Orient the IC so that its notched end corresponds with the notch printed on the board, and pin 1 of the IC corresponds with the arrowhead printed on the board.

NOTE: If the IC does not have a notch on one end, refer to the IC Orientation Chart included in your manual for the identification of pin 1.

- (-) When you have the correct orientation, start the pins on one side of the IC into their respective holes on the silk-screened side of the PC board. DO NOT PUSH THE PINS IN ALL THE WAY. If you have difficulty getting the pins into the holes, use the tip of a small screwdriver to guide them.

- (-) Start the pins on the other side of the IC into their respective holes in the same manner. When all of the pins have been started, set the IC into place by gently rocking it back and forth until it rests as close as possible to the board. Make sure that the IC is perfectly straight and as close to the board as possible; then tape it in place with a piece of masking tape.

- (-) Turn the board over and solder each pin of the IC to the foil pattern on the back side of the board. Be sure to solder each pin and be careful not to leave any solder bridges.

- (-) Turn the board over again and remove the piece of masking tape.

Use the same procedure to install each of the IC's. Be sure that you have the correct part number and the correct orientation as you install each one.

check first side of board

Address Hardware Connections

There are four hardwire connections to be made on the 8800 4K RAM Board which set the starting address for the particular board being wired.

The address chosen for each memory board must be correlated with the rest of the system in which it is to be used. Refer to the MEMORY ADDRESS SELECTION section of your manual for the necessary information to determine these connections.

These four connections are to be made using the component leads saved from earlier in the assembly procedure. Bend the leads as necessary to fit the correct holes on the board, and insert them from the silk-screened side. Solder the leads to the foil pattern on the back side of the board; then clip off any excess lead lengths.

Be careful not to leave any solder bridges.

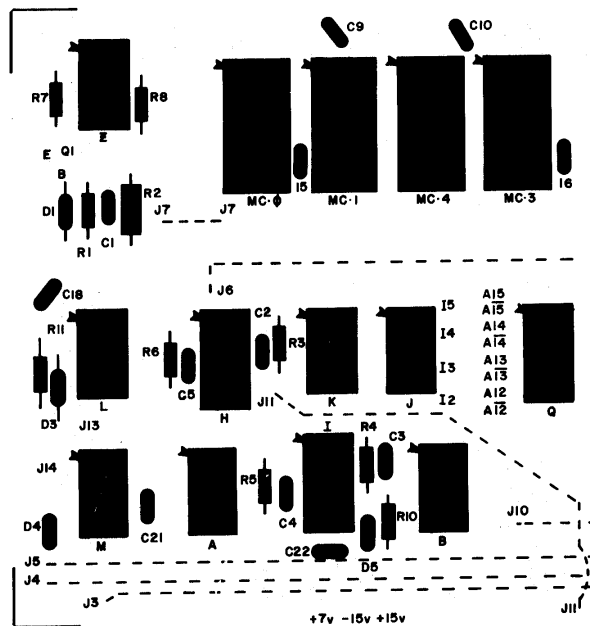

The board should be installed with the same orientation as the other boards in your 8800.

4K RAM BOARD POWER SUPPLY
**** MODIFICATION ****

THE FOLLOWING MODIFICATION MUST BE PERFORMED ON THE 5 VOLT SUPPLY REGULATION CIRCUITRY.

- (✓) Solder two 20-ohm resistors (red-black-black) together. Make the connection so that the two are as close as possible to each other. (see drawing below)
- (✓) Referring to the drawing, place a piece of electrical tape over the area on the board where the resistors will rest.
- (✓) Solder the resistors in place directly to the PC lands. One side will go to the 7805 lead closest to the IC labeled MC-6. The other side goes to the land connecting one side of C24 and the top pad for jumper J1. (see drawing and component layout below)

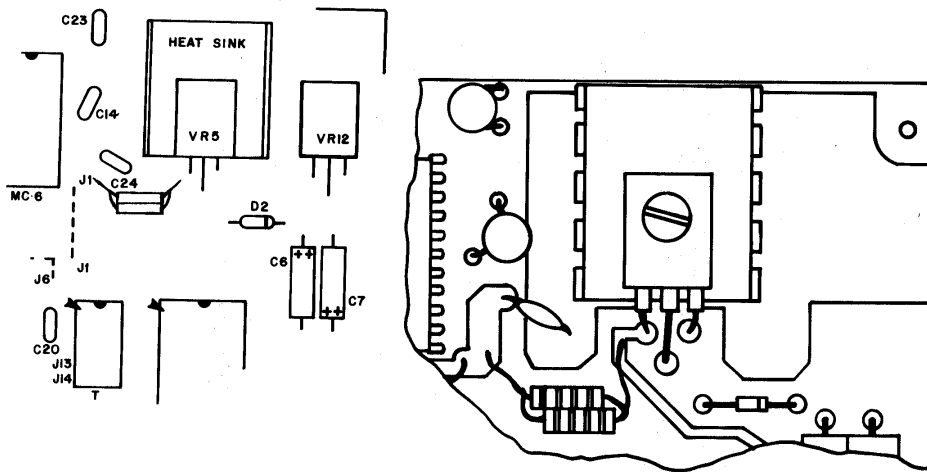

A

MEMORY ADDRESS SELECTION

There are several hardwire connections to be made on the 8800 memory boards for selecting the starting address for each board.

The starting address for each individual board is entirely optional within a few limitations. With only a single memory board in your system there is no problem, as long as the starting address selected is noted and taken into account when programming.

When more than one memory board is in the system, the sequence of starting addresses becomes critical. This is especially true when combining 1K and 4K boards in the same system. The important aspect in this case is to be sure that the individual blocks of memory on each board follow each other sequentially. There should be no gaps between the last address of one board and the starting address of the next.

The best example of this situation would be a system containing a 1K board with only 256 words of static memory together with a full 4K dynamic memory board. As may be noted from the "MEMORY ADDRESS SELECTION CHART", the starting address of the 1K boards may be selected with minimum increments of 1024 words. For the 4K board the minimum increment is 4096 words.

NOTE: Those addresses marked with an asterisk (*) in the chart are the possible address selections for the 4K boards, I1 & I0 being dropped for this board. Any address listed may be selected for the 1K boards.

As may be seen from studying the chart, in the example above if the 1K board is placed at an address "before" the 4K board there will be a gap of 3840 words of memory between the boards. Even with the 1K board expanded to its full 1024 words, there would still be a gap of 3072 words of memory.

In this example the 4K board address must be placed "before" the 1K board address in order to keep all possible addresses sequential. (i.e.--place the 4K board at octal address 0 and the 1K board at octal address 10 000)

The same would hold true for two 1K boards, one fully expanded and the other with only 256 words of memory. The full board must be placed first and the second board must be placed so that it follows immediately in sequence.

The chart below illustrates the address selection pads for both the 1K and the 4K memory boards. The "I" prefixed pads correspond to the "I" prefixed headings on the "MEMORY ADDRESS SELECTION CHART". The "A" prefixed pads correspond to the 1's and 0's on the "MEMORY ADDRESS SELECTION CHART" as indicated at the bottom of the chart below. The last number of the pad should always correspond in each connection. (i.e.--pad I5 must go to either A15 or $\bar{A}15$, pad I1 must go to either A11 or $\bar{A}11$)

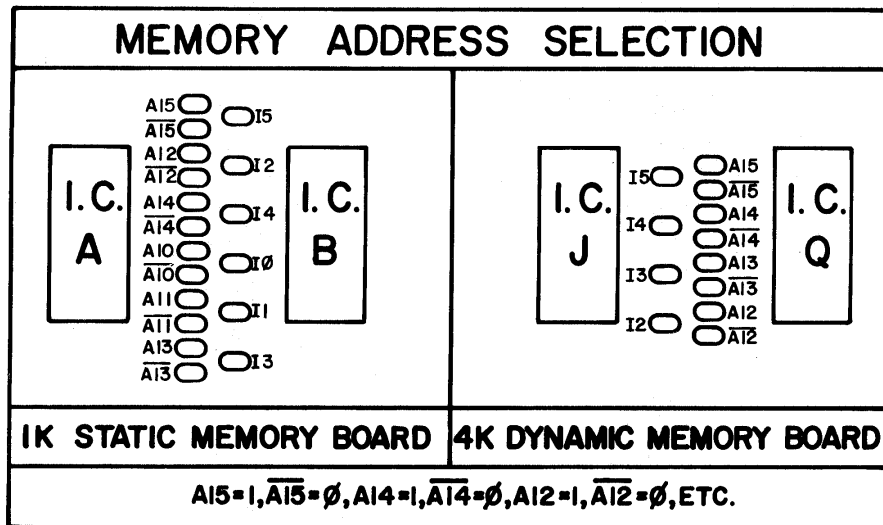

MEMORY ADDRESS SELECTION CHART

ADDRESS LINES						ADDRESS SELECTED	
I5	I4	I3	I2	I1	I0	DECIMAL ADDRESS	OCTAL ADDRESS
0	0	0	0	0	0	0	0 *
0	0	0	0	0	1	1,024	2 000
0	0	0	0	1	0	2,048	4 000
0	0	0	0	1	1	3,072	6 000
0	0	0	1	0	0	4,096	10 000 *
0	0	0	1	0	1	5,120	12 000
0	0	0	1	1	0	6,144	14 000
0	0	0	1	1	1	7,168	16 000
0	0	1	0	0	0	8,192	20 000 *
0	0	1	0	0	1	9,216	22 000
0	0	1	0	1	0	10,240	24 000
0	0	1	0	1	1	11,264	26 000
0	0	1	1	0	0	12,288	30 000 * ✓
0	0	1	1	0	1	13,312	32 000 ✓
0	0	1	1	1	0	14,336	34 000 ✓
0	0	1	1	1	1	15,360	36 000
0	1	0	0	0	0	16,384	40 000 * ✓
0	1	0	0	0	1	17,408	42 000 ✓
0	1	0	0	1	0	18,432	44 000
0	1	0	0	1	1	19,456	46 000
0	1	0	1	0	0	20,480	50 000 *
0	1	0	1	0	1	21,504	52 000

ADDRESS LINES						ADDRESS SELECTED	
I5	I4	I3	I2	I1	I0	DECIMAL ADDRESS	OCTAL ADDRESS
0	1	0	1	1	0	22,528	54 000
0	1	0	1	1	1	23,552	56 000
0	1	1	0	0	0	24,576	60 000 *
0	1	1	0	0	1	25,600	62 000
0	1	1	0	1	0	26,624	64 000
0	1	1	0	1	1	27,648	66 000
0	1	1	1	0	0	28,672	70 000 *
0	1	1	1	0	1	29,696	72 000
0	1	1	1	1	0	30,720	74 000
0	1	1	1	1	1	31,744	76 000
1	0	0	0	0	0	32,768	100 000 *
1	0	0	0	0	1	33,792	102 000
1	0	0	0	1	0	34,816	104 000
1	0	0	0	1	1	35,840	106 000
1	0	0	1	0	0	36,864	110 000 *
1	0	0	1	0	1	37,888	112 000
1	0	0	1	1	0	38,912	114 000
1	0	0	1	1	1	39,936	116 000
1	0	1	0	0	0	40,960	120 000 *
1	0	1	0	0	1	41,984	122 000
1	0	1	0	1	0	43,008	124 000
1	0	1	0	1	1	44,032	126 000
1	0	1	1	0	0	45,056	130 000 *
1	0	1	1	0	1	46,080	132 000

ADDRESS LINES						ADDRESS SELECTED	
I5	I4	I3	I2	I1	I0	DECIMAL ADDRESS	OCTAL ADDRESS
1	0	1	1	1	0	47,104	134 000
1	0	1	1	1	1	48,128	136 000
1	1	0	0	0	0	49,152	140 000 *
1	1	0	0	0	1	50,176	142 000
1	1	0	0	1	0	51,200	144 000
1	1	0	0	1	1	52,224	146 000
1	1	0	1	0	0	53,248	150 000 *
1	1	0	1	0	1	54,272	152 000
1	1	0	1	1	0	55,296	154 000
1	1	0	1	1	1	56,320	156 000
1	1	1	0	0	0	57,344	160 000 *
1	1	1	0	0	1	58,368	162 000
1	1	1	0	1	0	59,392	164 000
1	1	1	0	1	1	60,416	166 000
1	1	1	1	0	0	61,440	170 000 *
1	1	1	1	0	1	62,464	172 000
1	1	1	1	1	0	63,488	174 000
1	1	1	1	1	1	64,512	176 000
Highest Directly Addressable Memory Location →						65,535	177 777

*4K Dynamic Memory Board Selections

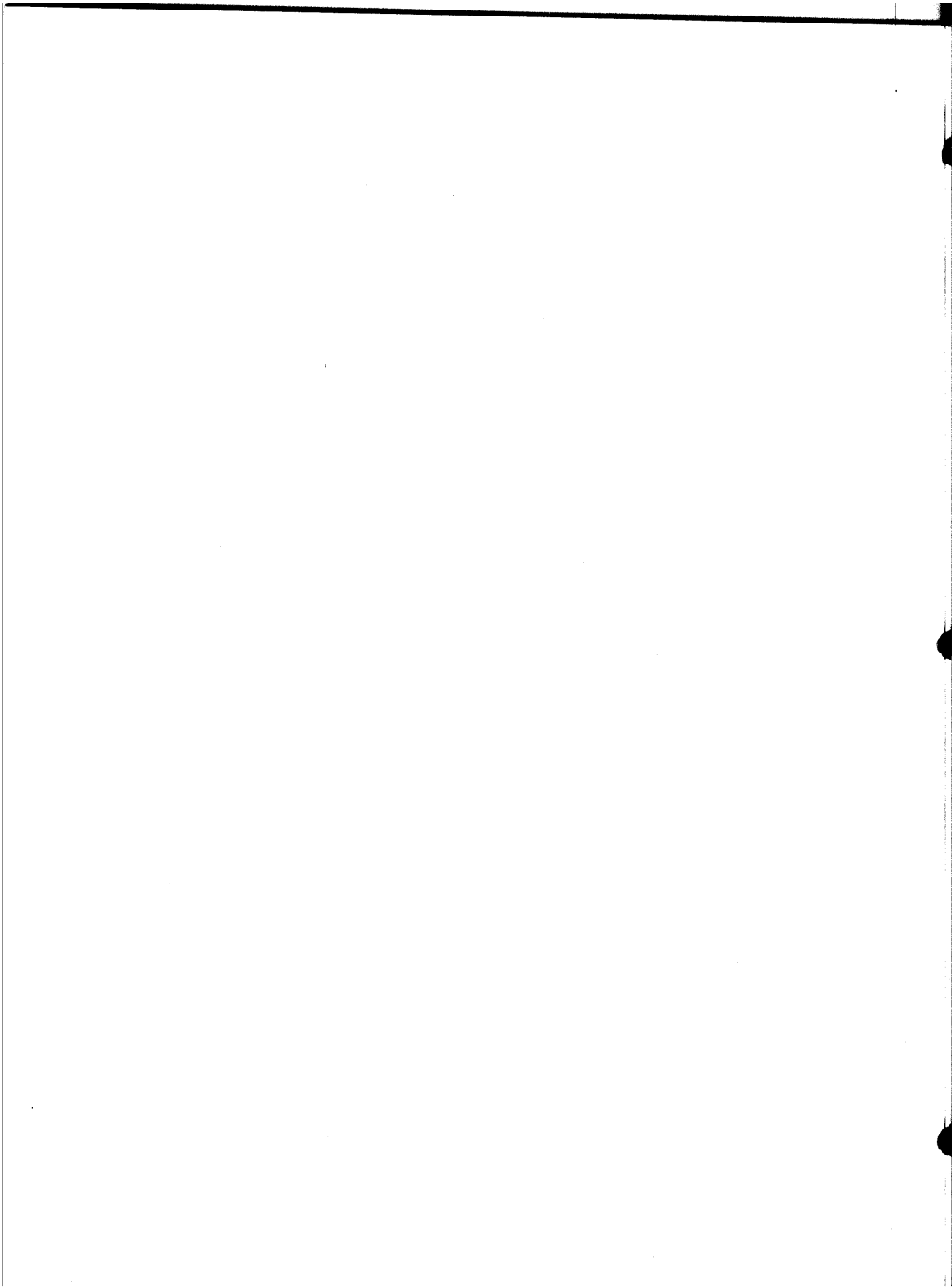

4K Dynamic Memory Board

A small number of 4K dynamic memory boards built and tested by MITS have shown problems with running BASIC. To correct this problem, we decreased the value of R6 (the resistor associated with the time constant of the H6 single-shot) from 43,000 ohms to 30,000 ohms. This will become a formal change on our next production run and we recommend that if your system does not appear solid that you try this change. We also recommend the installation of a fan if your system contains more than three 88-4MCD's.

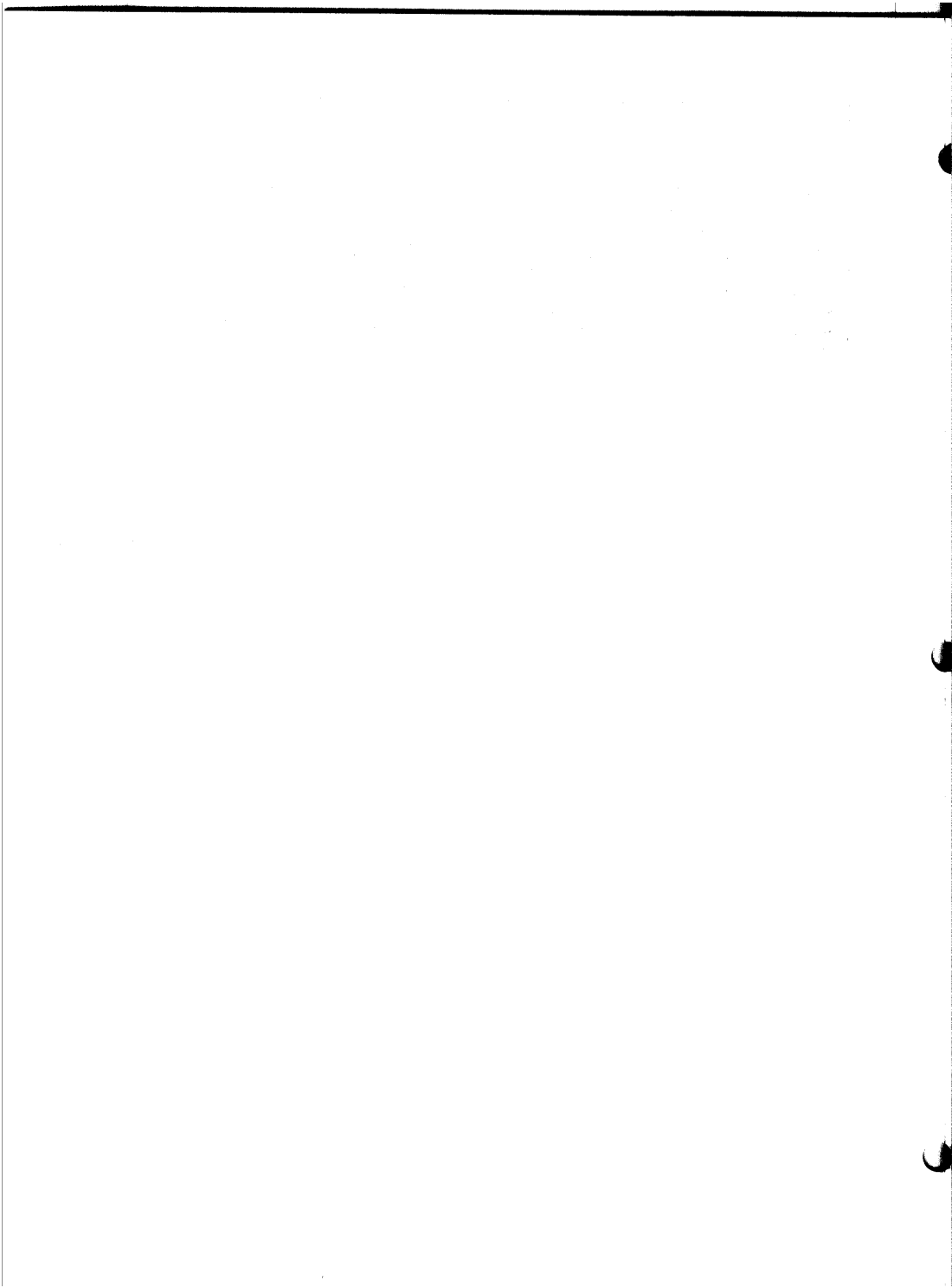

4K MEMORY BOARD ERRATA

IC's K and L (74L00) must be changed to 7400's and IC J (74L20) must be changed to a 7420.

We suggest that if the above IC's have already been installed that they be removed by clipping each pin of the IC and then removing each pin with a pair of needle nose pliers and soldering iron.

If you do not wish to undergo the above, please return the board to the factory for modification.

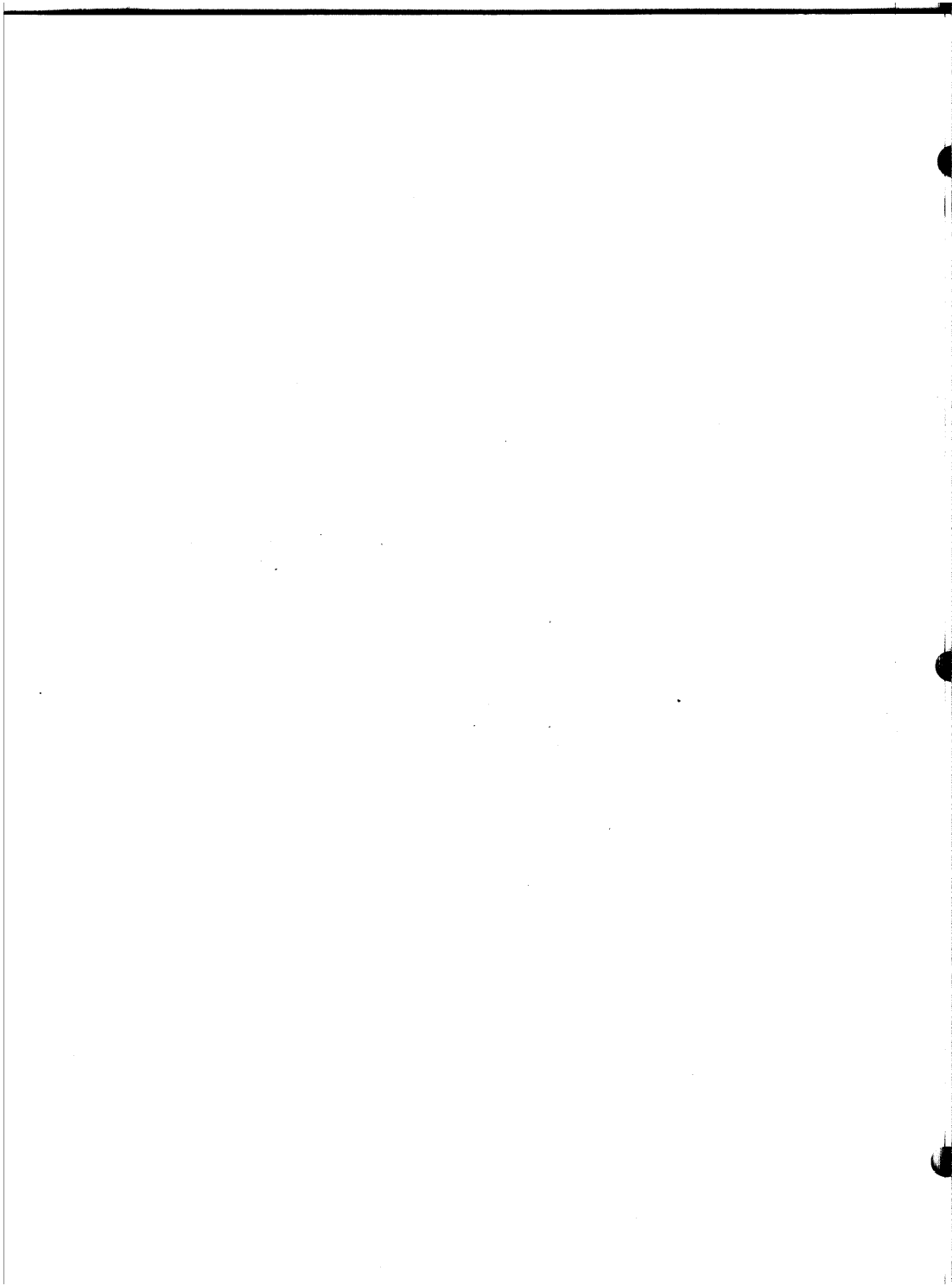



MITTS

"Creative Electronics"

*Rev 0 Boards altered by MITTS
see next page*

Dear 4K Kit Customer:

To avoid undue delay of your kit, we are taking the liberty of shipping your kit -- minus the following parts:

	8	2107A IC
		

We have taken this action so that you may begin preliminary work on your unit. The missing parts will be shipped to you as soon as we receive them.



4K MEMORY BOARD ERRATA

REVISION 0.2

THE FOLLOWING ADDITIONS AND CHANGES APPLY TO ALL "REV 0.2" 4K RAM BOARDS. BE SURE TO READ THESE OVER CAREFULLY BEFORE BEGINNING CONSTRUCTION. WITH THESE EXCEPTIONS, THE REST OF THE ASSEMBLY PROCEDURE IS AS STATED IN THE MANUAL.

There are four additional components to be added to the board which are not shown on the silk-screen. These include a diode, a resistor and two capacitors.

Refer to the component layout drawing on page 3 of this errata and install the additional components in the positions shown.

NOTE: The .1uf capacitor is not shown in the schematic. This capacitor is merely for noise suppression.

THE LEFT SIDE OF JUMPER J6 SHOULD NOT BE CONNECTED TO THE PAD INDICATED BY THE SILK-SCREEN ON THE BOARD. IN THE DRAWING YOU WILL NOTE THAT THE PAD FOR THE LEFT SIDE OF THIS JUMPER IS NOW LOCATED JUST BELOW IC L.

The following information applies to specific pages of the assembly manual:

PAGE 3: IC B is now a 74LS04, IC L is now a 74LS00

PAGES 8 & 9: Diode D2, listed in the instructions as a 1N746A, 3.3v zener, will be so only if your kit contains TMS 4030 memory IC's. If your kit is supplied with the Intel C2107A's or TMS 4060-2's, then this diode will be a 1N4733, 5v zener instead.

PAGES 10 & 11: The markings on the silk-screen for two of the jumper wire connections are incorrect. Just beneath IC S, there are two pads next to each other labeled J2 & J10. These two pads have reverse markings; J2 should be J10, and J10 should be J2. Connect them accordingly.

4K MEMORY BOARD ERRATA

THERE HAVE BEEN IC SOCKETS ADDED TO YOUR KIT FOR MOUNTING SEVERAL OF THE INTEGRATED CIRCUITS.

A 24 PIN IC SOCKET HAS BEEN ADDED FOR IC N. THIS MAY BE ONE OF TWO TYPES. ONE TYPE IS A SINGLE UNIT AND WILL FIT DIRECTLY INTO THE HOLES ON THE BOARD FOR MOUNTING THE IC. THE OTHER TYPE IS ACTUALLY TWO HALVES JOINED TOGETHER BY SOME CROSS PIECES. USE WIRE CUTTERS TO REMOVE THE CROSS PIECES, SEPARATING THE HALVES. MOUNT THE SOCKET TO THE BOARD IN THE SAME MANNER AS YOU WOULD AN INTEGRATED CIRCUIT, THEN INSTALL THE IC INTO THE SOCKET.

SOCKETS HAVE ALSO BEEN PROVIDED FOR THE MEMORY IC'S, MC-0 THROUGH MC-7. THESE SOCKETS MAY ALSO BE ONE OF TWO DIFFERENT TYPES. ONE TYPE WILL BE A SINGLE 22 PIN UNIT AND SHOULD BE INSTALLED IN THE SAME MANNER AS THE ONE MENTIONED ABOVE. THE OTHER TYPE IS EXACTLY LIKE THE TWO PIECE ONE MENTIONED ABOVE, AND SHOULD BE SEPARATED IN THE SAME MANNER. THIS ONE WILL ALSO REQUIRE A MODIFICATION IN ORDER TO ACCOMODATE THE 22 PIN IC'S. USE NEEDLE-NOSE PLIERS TO PULL ONE OF THE END PINS FROM EACH OF THE 16 SOCKET HALVES. WHEN MOUNTING THESE, KEEP THE HOLE WITH THE PIN MISSING TOWARDS THE BOTTOM OF THE BOARD. KEEP THE IC TOWARDS THE TOP OF THE BOARD WHEN INSTALLING IT SO THAT THE HOLE WITH THE MISSING PIN IS NOT USED.

PAGE 13: Before installing IC MC-1, there is a track running close to one of the IC pads which should be inspected. On the side closest to capacitor C15 there is a PC land which runs between the pads for pins 7 & 8 of the IC. This land runs extremely close to the pad for pin 7.

Check this area of the board very closely, and be sure that the land does not touch the pad. If there is a short, or if you are not certain; use a small sharp knife and cut slightly into the board between the two, just enough to be sure that there is no connection.

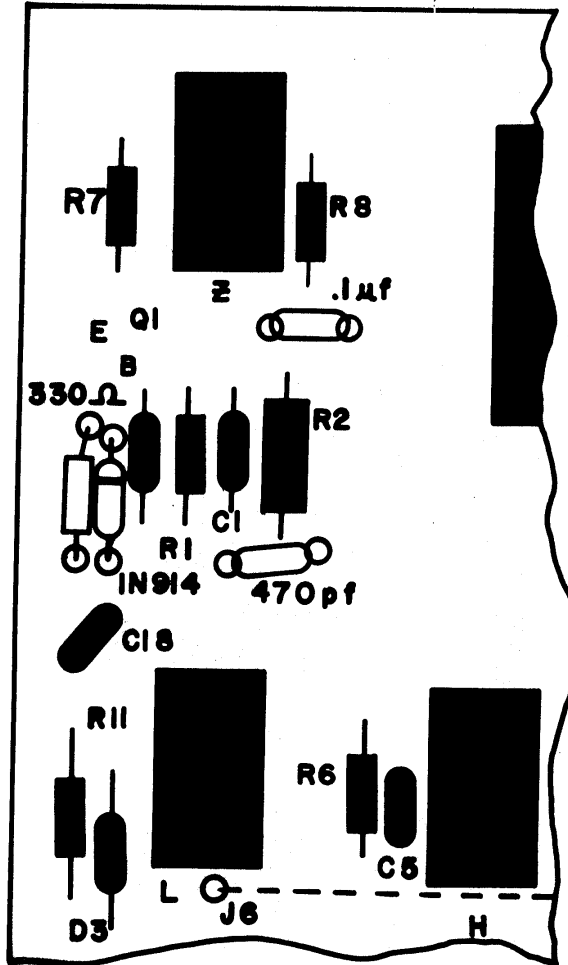

ORIGINAL COMPONENTS ARE SHOWN IN SOLID BLACK, THE ADDITIONAL COMPONENTS ARE THOSE SHOWN OUTLINED.

THESE INCLUDE:

- One .1uf capacitor
- One 470pf capacitor
- One 1N914 diode*
- One 330 ohm (orange-orange-brown) resistor

NOTE ALSO THE NEW LOCATION FOR THE NEW LOCATION FOR THE LEFT SIDE OF JUMPER J6.

*Be sure to align the band on the diode with the band shown in the drawing for the correct orientation.

4K RAM
REV 0.2

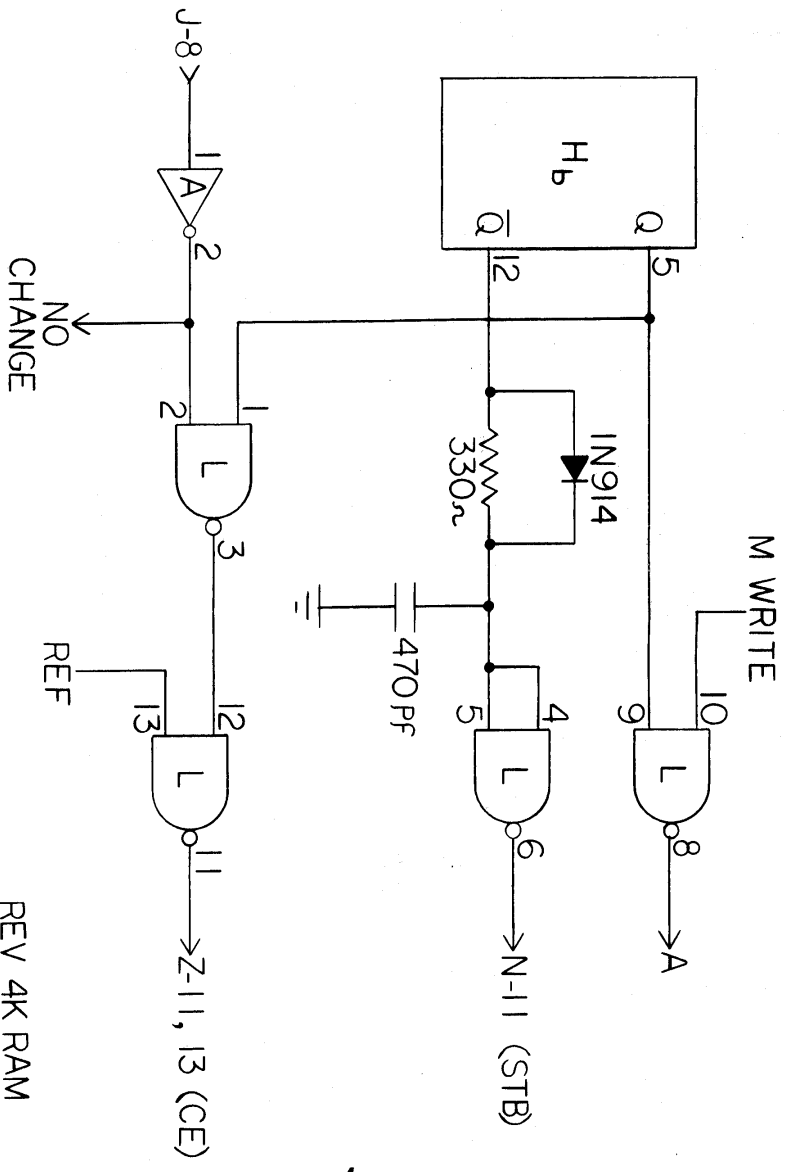

REV 4K RAM
BOARD
9-23-75

THE FOLLOWING APPLIES TO PAGE 3 OF THE ASSEMBLY MANUAL:

This is a corrected list of the integrated circuits to be installed on all REVISION 0.2 4K Memory Boards.

- () IC's A & R are 74L04's
- () IC B is a 74LS04
- () IC D is a 74193
- () IC's F & E are 74L193's
- () IC's G & T are 7473's
- () IC's H & I are AM26L123's
- () IC J is a 74L20
- () IC M is a 74L02
- () IC N is an 8212
- () IC's O, P, Q & S are 8T97's
- () IC K is a 74L00
- () IC L is a 74LS00
- () IC Z is a 7406

NOTE: *There are several errors in reference to this material, including the current Parts & BAG lists. Disregard all other instructions and references to these IC's.*



4K MEMORY BOARD ERRATA

THERE HAVE BEEN IC SOCKETS ADDED TO YOUR KIT FOR MOUNTING SEVERAL OF THE INTEGRATED CIRCUITS.

A 24 PIN IC SOCKET HAS BEEN ADDED FOR IC N. THIS MAY BE ONE OF TWO TYPES. ONE TYPE IS A SINGLE UNIT AND WILL FIT DIRECTLY INTO THE HOLES ON THE BOARD FOR MOUNTING THE IC. THE OTHER TYPE IS ACTUALLY TWO HALVES JOINED TOGETHER BY SOME CROSS PIECES. USE WIRE CUTTERS TO REMOVE THE CROSS PIECES, SEPARATING THE HALVES. MOUNT THE SOCKET TO THE BOARD IN THE SAME MANNER AS YOU WOULD AN INTEGRATED CIRCUIT, THEN INSTALL THE IC INTO THE SOCKET.

SOCKETS HAVE ALSO BEEN PROVIDED FOR THE MEMORY IC'S, MC-0 THROUGH MC-7. THESE SOCKETS MAY ALSO BE ONE OF TWO DIFFERENT TYPES. ONE TYPE WILL BE A SINGLE 22 PIN UNIT AND SHOULD BE INSTALLED IN THE SAME MANNER AS THE ONE MENTIONED ABOVE. THE OTHER TYPE IS EXACTLY LIKE THE TWO PIECE ONE MENTIONED ABOVE, AND SHOULD BE SEPARATED IN THE SAME MANNER. THIS ONE WILL ALSO REQUIRE A MODIFICATION IN ORDER TO ACCOMODATE THE 22 PIN IC'S. USE NEEDLE-NOSE PLIERS TO PULL ONE OF THE END PINS FROM EACH OF THE 16 SOCKET HALVES. WHEN MOUNTING THESE, KEEP THE HOLE WITH THE PIN MISSING TOWARDS THE BOTTOM OF THE BOARD. KEEP THE IC TOWARDS THE TOP OF THE BOARD WHEN INSTALLING IT SO THAT THE HOLE WITH THE MISSING PIN IS NOT USED.



8800 ERRATA SHEET

PAGE 11 OF THE 8800 ASSEMBLY MANUAL IS TO BE CHANGED AS FOLLOWS:
CAPACITOR C7 IS TO BE CHANGED TO A .0047 microfarad capacitor
INSTEAD OF THE .001uf CAPACITOR CALLED FOR IN THE INSTRUCTIONS.

Substitution:

33mF 16V capacitor substitute for 35mF 16V capacitor.



88-4MCD
(4K Dynamic RAM)
Parts List
June, 1975

BAG 1

1	MC7805	101074
1	MC7812	101085
2	26L123	101066
2	SN74L00	101080
1	SN74L02	101072
3	SN74L04	101073
1	SN7406	101054
1	SN74L20	101039
2	7473	101027
2	SN74L193	101087
1	SN74193	101037
4	N8T97	101040

BAG 2

1	8212	101071
8	TMS4030 or 2107A	101076
8	22 pin sockets	102108
1	24 pin socket	102105

BAG 3

2	.001mF 12v cer	100328
1	470pF 10v cer	100316
3	33mF 16v elec	100326
2	20pF 12v cer	100334
1	100pF 12v cer	100361
1	220pF 12v cer	100314
1	.0047uF (4700M)	100324

BAG 4

18	.1mF 12v cer	100348
----	--------------	--------

BAG 5

2	#6-32 nut	100933
2	6-32 lockwasher	100942
2	#6-32x1/2" screw	100918
1	Heat sink	101870
1	24" 20-gauge wire	103063
3	36" 26-gauge wire	103060
1	Edge connector	101864
2	Card guides	101714

BAG 6

1	EN2907	102804
4	IN914	100705
1	5.1v zener or	100721
1	3.3v zener	100708

BAG 7

2	100 ohm 1/2w	101924
3	1K ohm 1/2w	101928
1	22K ohm 1/2w	101933
1	20K ohm 1/2w	101940
1	27K ohm 1/2w	101989
1	43K ohm 1/2w	101988
2	470 ohm 1/2w	101927
2	20 ohm 1/2w	102048

MISCELLANEOUS

1	PC board Manuals	100100 101549
---	---------------------	------------------

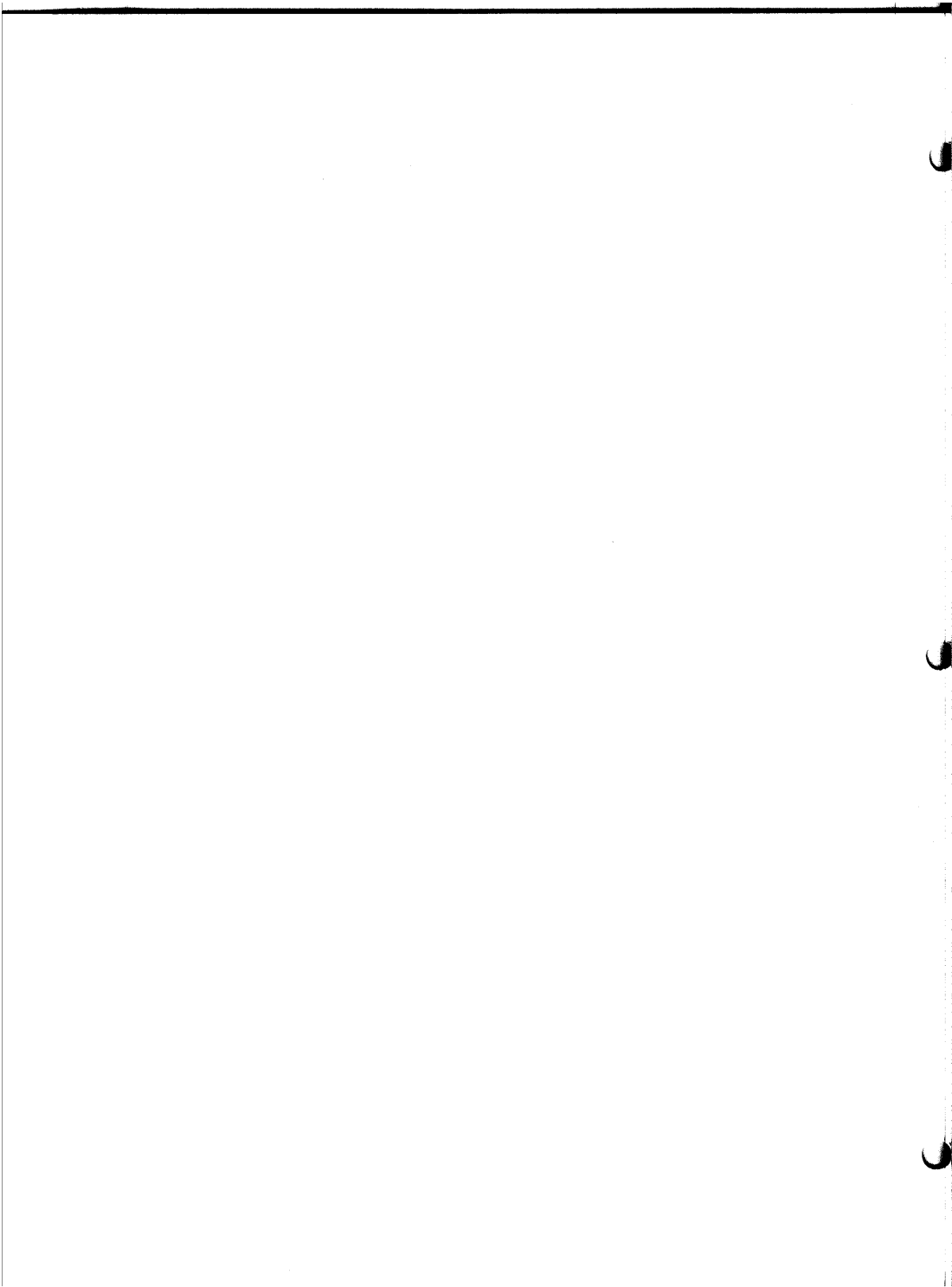

4 K RAM BOARD

DOCUMENTATION

CONTENTS

THEORY OF OPERATION

SCHEMATICS

ASSEMBLY PROCEDURE

© MITS, Inc., 1975

PRINTED IN U.S.A.

MIT S
"Creative Electronics"

P.O. BOX 8636
ALBUQUERQUE, NEW MEXICO 87108

THEORY of OPERATION

88-4MCD 4K DYNAMIC RAM BOARD OPERATION

The 4K RAM Board provides 4,096 words of Dynamic Random Access Memory for the ALTAIR 8800. Each individual board contains memory protect circuitry, and address selection circuitry for any one of 16 starting address locations in increments of 4K. The maximum access time is 300 nanoseconds; thus, there is no "wait" requirement unless Refresh is occurring at the time of access.

Refresh

This memory board is designed around a dynamic integrated circuit, TMS 4030 or C2107A IC's. These dynamic IC's require each row within the chip to be accessed every 2 milliseconds or less. This is accomplished by accessing one of the 64 rows every 64 clock pulses (32 microseconds).

The $\phi 2$ clock is buffered through one gate of IC S and then inverted through one gate of IC A. It is then divided in half through flip-flop Ta, and divided again by 16 through a 4-bit counter (IC D). The final signal is fed to the clock input of flip-flop Ga. Thus, after 32 clock pulses Ga will toggle, and will toggle again after another 32 clock pulses. This will add one count to the 6-bit counter, IC's E & F, which sets up the refresh address at the inputs of IC O.

Ga is also used to trigger single-shot Ha. This partially enables IC K pin 11 and toggles flip-flop Gb, partially enabling IC K pin 3.

If the computer is in the run mode, a SYNC pulse, inverted through one gate of IC A, will occur within approximately 10 microseconds. This causes IC K pin 11 to go low for 500 nanoseconds and IC K pin 3 to go high for 500 nanoseconds. On the falling edge of this pulse, single-shot Ia is triggered. The pulse from IC Ia pin 13 disables the machine address and triggers IC Ib. The IC Ia pin 4 output is delayed less than 100 nanoseconds and fed to the chip-enable voltage level shift circuit (4 gates of IC Z, Q1, R1, R2, D1 & C1) and also clears flip-flop Gb.

The output of this circuit provides a 500 nanosecond, +12 volt pulse to the RAM IC's to accomplish the required access.

If the machine had been in a stop mode when the refresh pulse occurred, there would have been no SYNC pulse. In this case refresh would have occurred with the falling edge of the pulse from IC Ha, approximately 12 microseconds later.

The function of IC Ib is to disable the read-write single-shot, IC Hb, and to pull the Ready line active if the card is accessed during refresh. This puts the machine in a wait state until refresh has been accomplished. IC Hb is then triggered for a normal read or write.

Read

IC Hb is partially enabled by MEMR. When SYNC and Q1 occur, if refresh is not occurring keeping IC J pin 4 low, then IC K pin 8 goes low and pulls IC J pin 6 high. Approximately 90 nanoseconds later Q1 returns low, IC K pin 8 goes high and IC J pin 6 goes low triggering IC Hb. This pulls chip enable (CE) high for 500 nanoseconds.

After approximately 300 nanoseconds the data out of the RAM chips is valid. It is latched into the 8-bit latch (IC N) via the strobe input, IC N pin 11, by IC Hb pin 5.

The final requirement to place the data onto the bus is with the latch enable inputs, pins 1 & 13 of IC N. Pin 1 is pulled low by IC J pin 8 (card select) and pin 13 is pulled high by MEMR. This enables the latch outputs and presents the data to the bus.

Write

The write mode is identical to the read mode, except that the latch outputs are not enabled and the write inputs to the RAMS are activated.

The MWRITE signal partially enables the read-write single-shot, IC Hb, and is also gated with the output of Hb to IC L pins 9 & 10. When both signals are high (active) IC L pin 8 goes low. If memory is unprotected (IC M pin 6), IC M pin 4 goes high and IC A pin 4 goes low.

This pulls the write input of the memory chips to the low active write mode while at the same time chip enable is high (Hb pin 12) and the data (buffered and inverted through IC's R & Z) is present at the RAM data inputs.

Protect

The entire 4,096 words of memory on the board can be protected via the front panel PROTECT switch.

When the card is selected (IC M pin 3) and the switch lifted to the PROTECT position (IC M pin 2), the output of IC M pin 1 toggles the flip-flop Tb. This pulls IC M pin 6 high to disable the write input to the RAMS, and pulls buffer IC S pins 13 & 14 low to light the PROTECT light on the front panel.

The memory will remain protected until power is turned off or the PROTECT switch is pushed to the UNPROTECT position.

When power is first applied to the unit the \overline{POC} signal (Power On Clear) is pulled low for several milliseconds, insuring that the memory is unprotected.

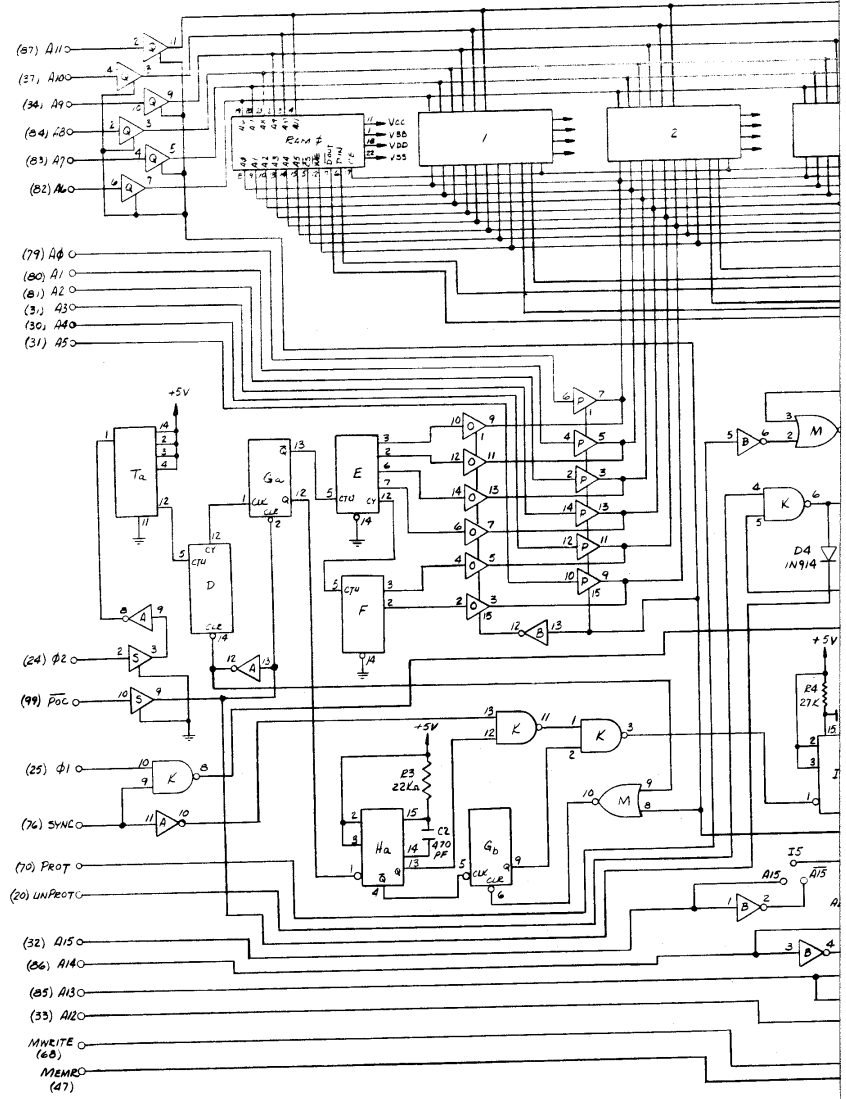

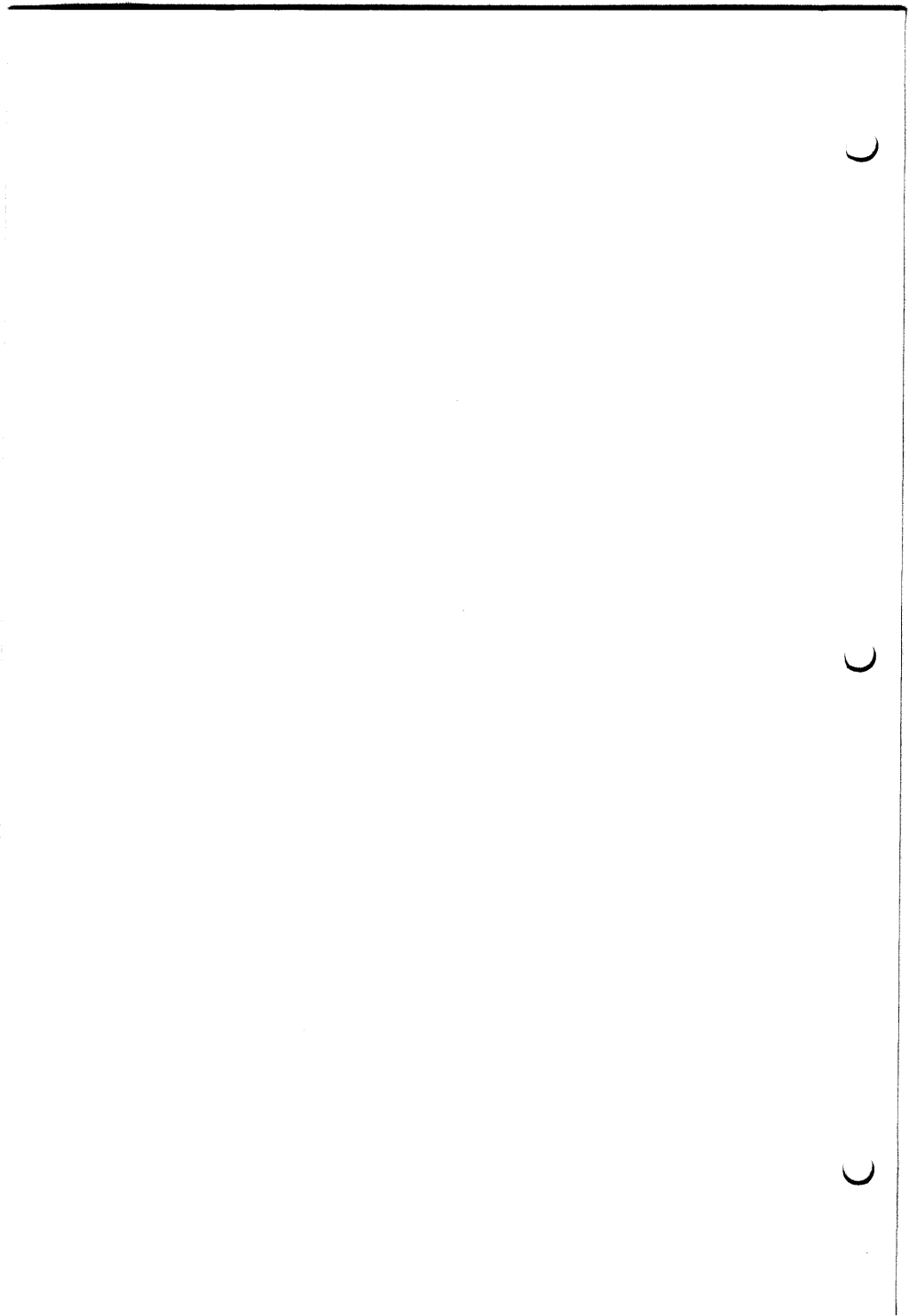

U

U

U



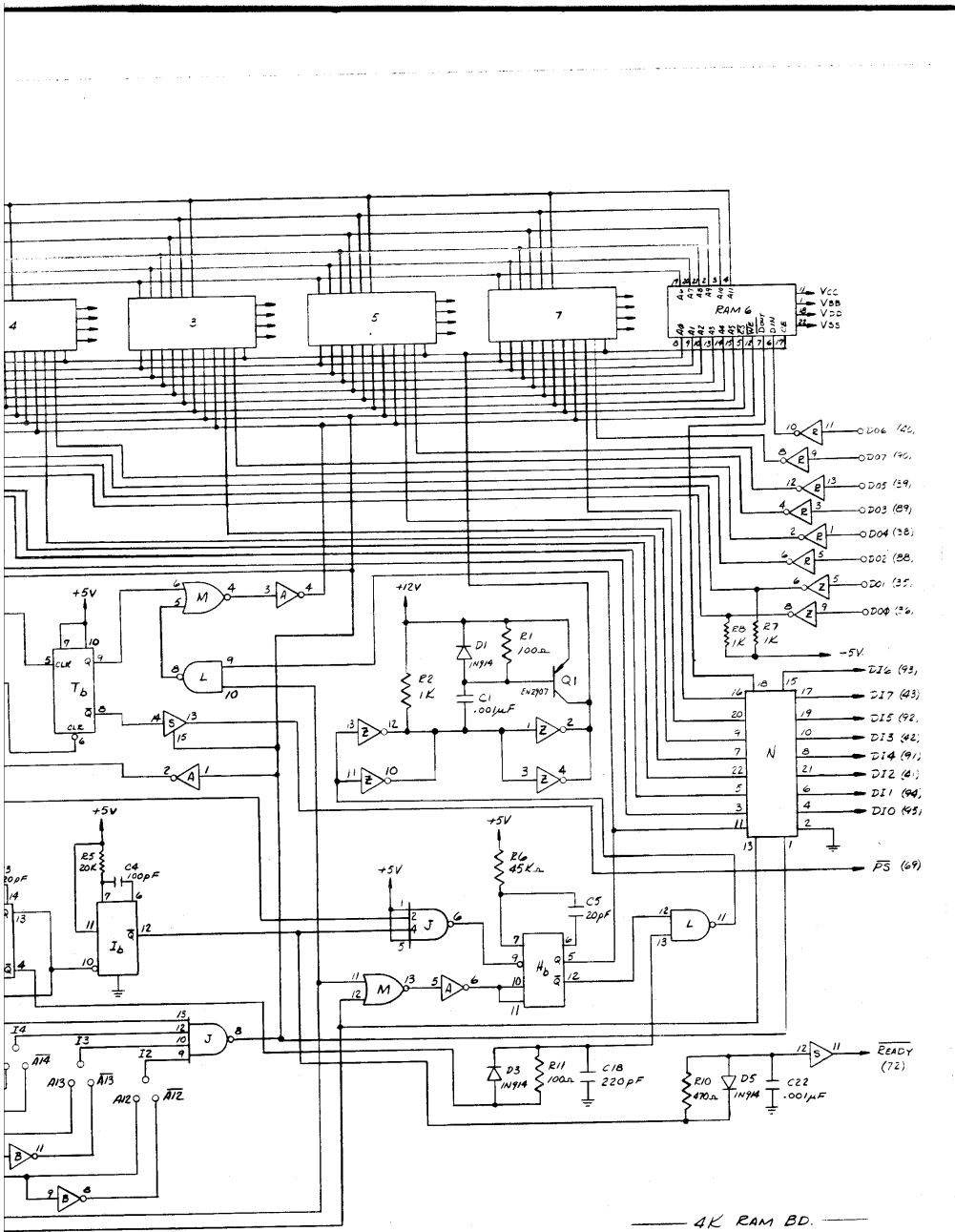

— 4K RAM BD. —

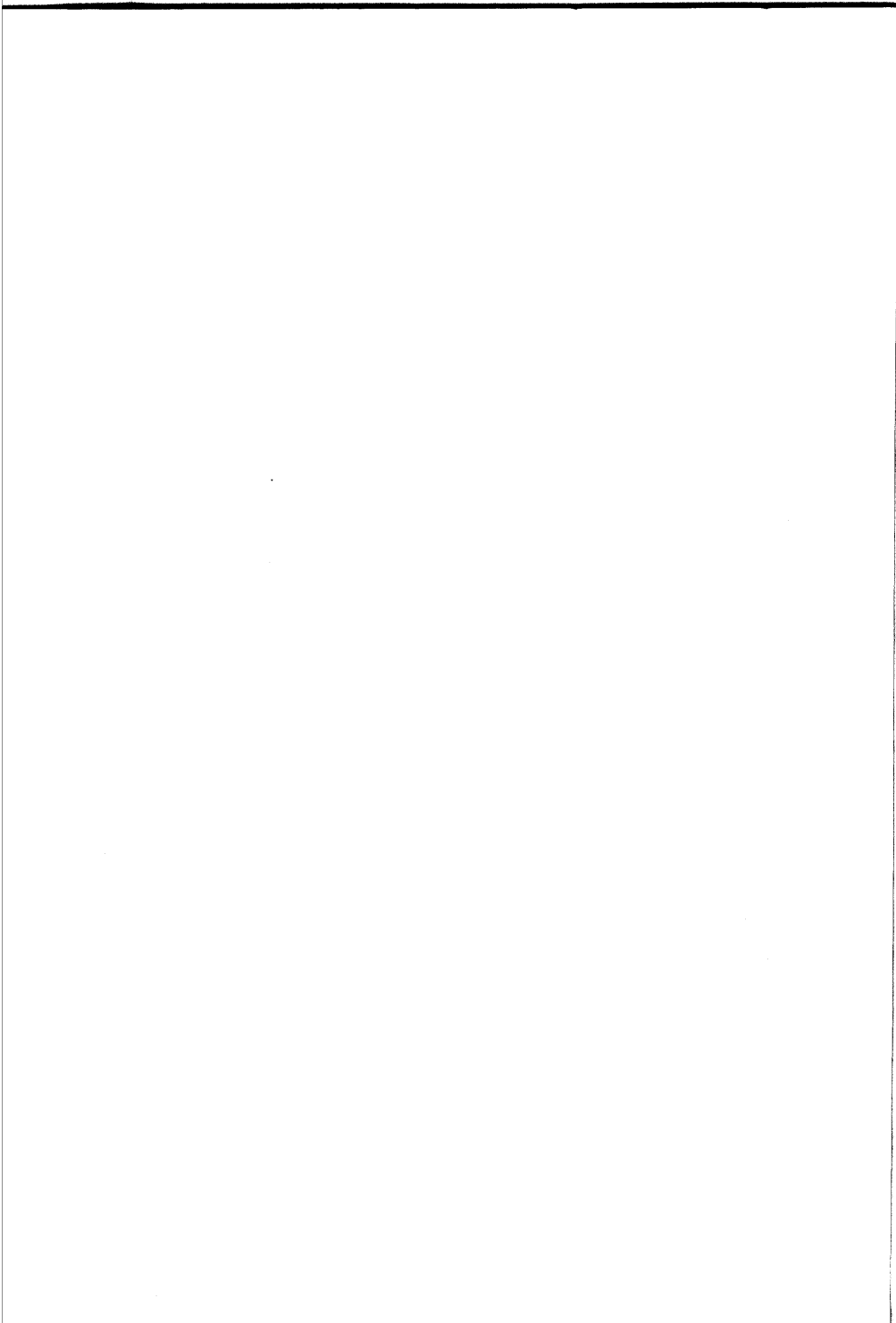

C

C

C

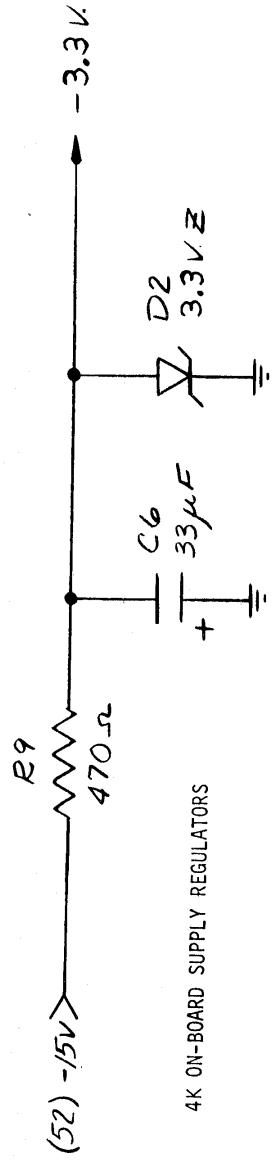
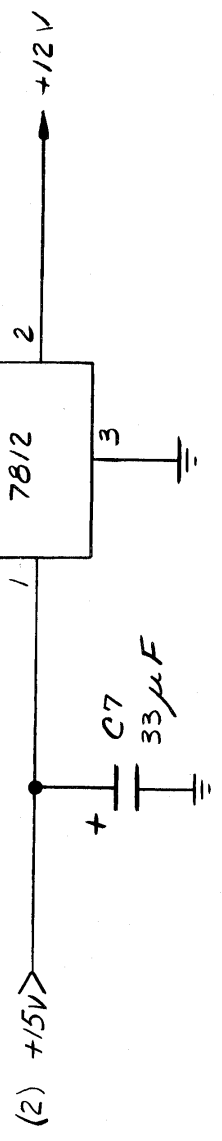
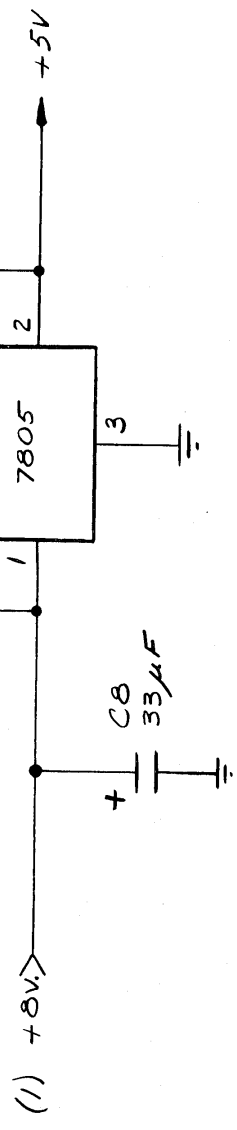

4K ON-BOARD SUPPLY REGULATORS

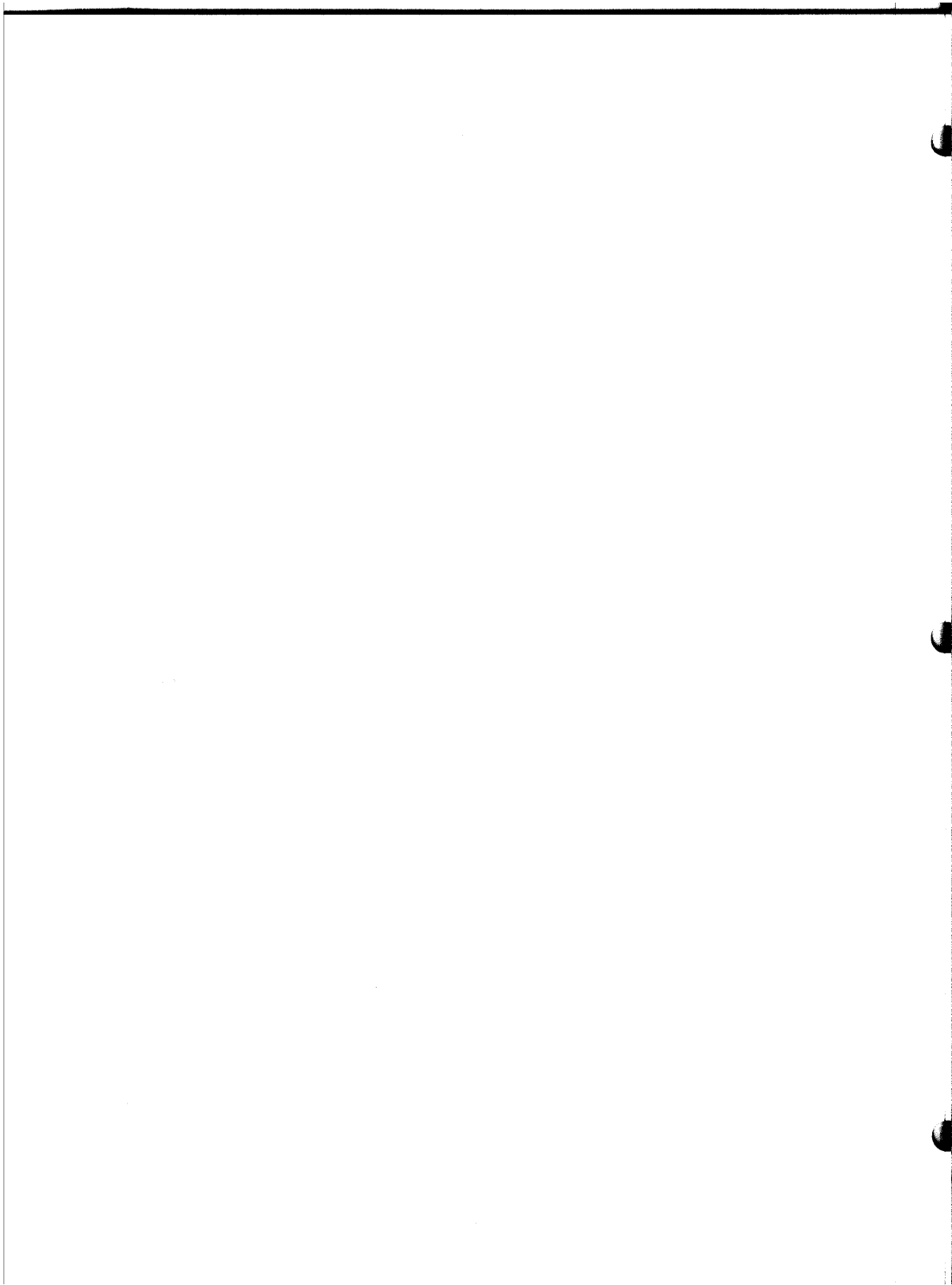

4K MEMORY BOARD ERRATA SHEET

PLEASE READ THIS BEFORE PROCEEDING! THE FOLLOWING ERRATA
PERTAINS TO THE PAGES LISTED ON THE LEFT.

PAGE 6: There is an additional .1uf ceramic disk capacitor to be installed on the board besides those listed in the instructions. This capacitor is to be installed directly to components already on the board in the upper left corner.

Solder one lead of the capacitor to the topmost lead of resistor R7. Solder the other lead to pin 7 of IC Z. When soldering to the IC pin, be very careful that you do not create solder bridges to any other pins or PC lands. Keep the leads of the capacitor as short as possible without shorting them to any other components or PC lands.

PAGES 8 & 9: Diode D2, listed in the instructions as a 1N746A, 3.3v zener, will be so only if your kit contains TMS 4030 memory IC's. If your kit is supplied with the Intel C2107A's, then this diode will be a 1N4733, 5v zener instead.

PAGES 10 & 11: The markings on the silk-screen for two of the jumper wire connections are incorrect. Just beneath IC S, there are two pads next to each other labeled J2 & J10. These two pads have reverse markings; J2 should be J10, and J10 should be J2. Connect them accordingly.

PAGE 13: Before installing IC MC-1, there is a track running close to one of the IC pads which should be inspected. On the side closest to capacitor C15 there is a PC land which runs between the pads for pins 7 & 8 of the IC. This land runs extremely close to the pad for pin 7.

Check this area of the board very closely, and be sure that the land does not touch the pad. If there is a short, or if you are not certain; use a small sharp knife and cut slightly into the board between the two, just enough to be sure that there is no connection.



