

**Printer**

# **PR2 E**

**SERVICE MANUAL**

Code Y100250-4

**PUBLICATION ISSUED BY:**

**Olivetti TECNOST, S.p.A.**

Documentazione

77, Via Jervis - 10015 Ivrea (Italy)

*Copyright © 2001, Olivetti*

*All rights reserved*

## PREFACE

This Service Manual provides you with all the technical information needed to install, test and service the PR2 E specialized printer.

Consult this manual when the Operator Manual, included in the printer packaging, does not provide the information needed to correct a determined error condition.

### SUMMARY

This manual is divided into chapters, where each chapter is organized in a way that the information can be accessed as simply and quickly as possible.

The first two chapters give an overview of the machine and describe its major functions; Chapter 3 describes installation and testing procedures while the remaining chapters provide the information needed to effectively service the machine.

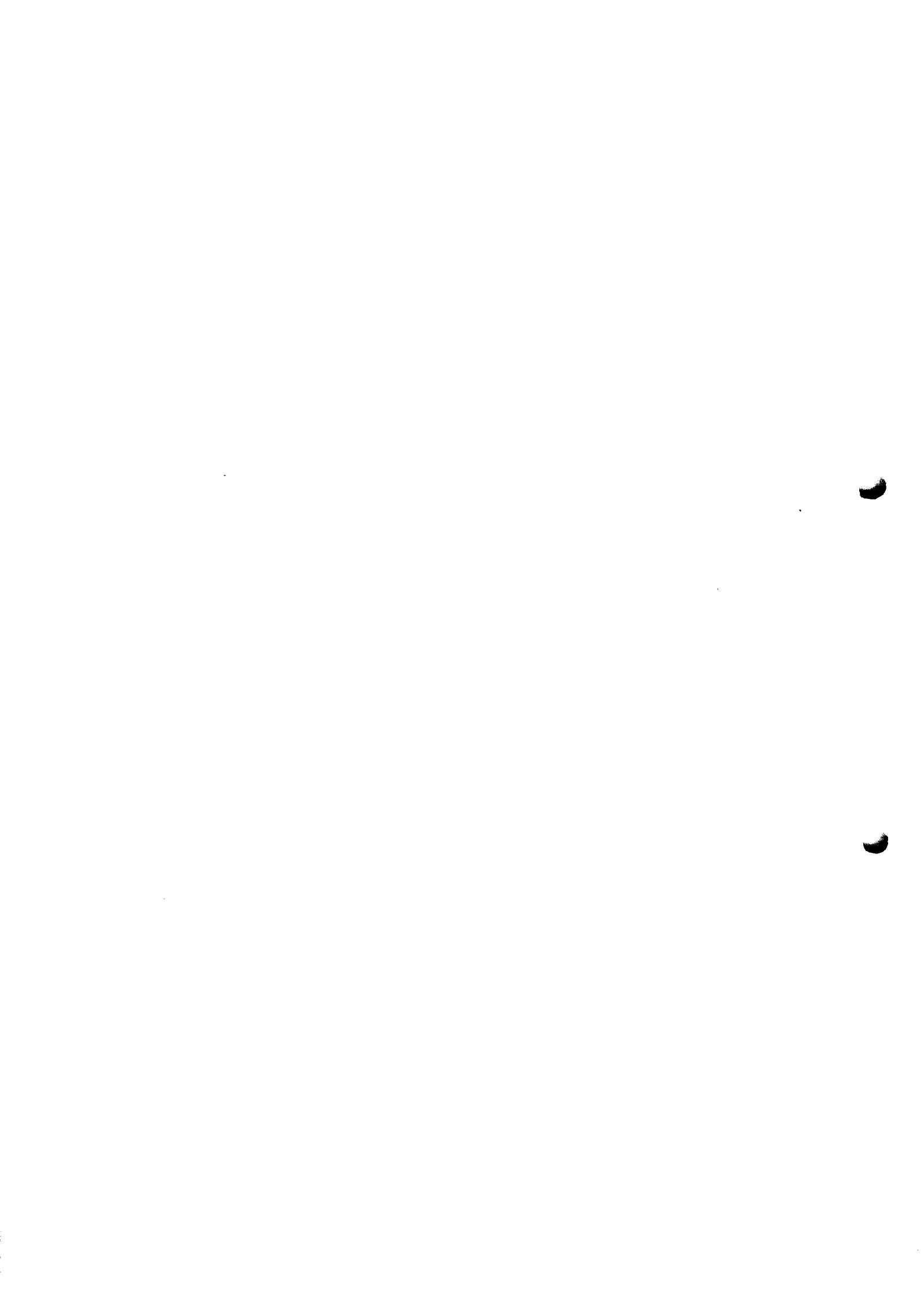
- **BIBLIOGRAPHY:** PR2 E Operator Manual  
PR2 E Programmer's Manual  
PR2 E Spare Parts Catalogue
- **SECTOR/PRODUCT RANGE:** Q2 PR2
- **DISTRIBUTION:** General (G)
- **FIRST EDITION:** April, 2001

---

#### NOTICE

Olivetti TECNOST S.p.A. reserves the right to make changes to the product described in this manual at any time and without notice.

---



# TABLE OF CONTENTS

## 1. PRODUCT OVERVIEW

<b>1.1</b>	<b>INTRODUCTION</b> .....	<b>1</b>
1.1.1	PR2 E FACTORY CONFIGURATION .....	2
<b>1.2</b>	<b>GENERAL MACHINE CHARACTERISTICS</b> .....	<b>3</b>
<b>1.3</b>	<b>HORIZONTAL MAGNETIC DEVICE/MICR FEATURES</b> .....	<b>4</b>
<b>1.4</b>	<b>PRODUCT VARIABLES</b> .....	<b>5</b>
<b>1.5</b>	<b>DOCUMENTS HANDLED BY THE BASIC MACHINE</b> .....	<b>6</b>
1.5.1	SINGLE AND MULTI-COPY FORMS .....	6
1.5.2	SAVINGS BOOKS .....	7
<b>1.6</b>	<b>ACCESSORIES</b> .....	<b>8</b>
<b>1.7</b>	<b>LOCATING THE PRINTER'S MAJOR COMPONENTS</b> .....	<b>9</b>
<b>1.8</b>	<b>LOCATING THE PRINTER'S MAJOR INTERNAL COMPONENTS</b> .....	<b>10</b>
<b>1.9</b>	<b>GENERAL BLOCK DIAGRAM</b> .....	<b>11</b>
1.9.1	BASIC MACHINE .....	11
<b>1.10</b>	<b>FIRMWARE AND CHARACTER GENERATORS</b> .....	<b>12</b>
1.10.1	MACHINE FIRMWARE .....	12
1.10.2	CHARACTER SETS .....	13
1.10.3	PRINT MODES AND CHARACTER FONTS .....	13

## 2. OPERATING COMMANDS .....

<b>2.1</b>	<b>POWER SWITCH</b> .....	<b>2</b>
<b>2.2</b>	<b>CONSOLE</b> .....	<b>2</b>
2.2.1	FUNCTIONS OF THE CONSOLE BUTTONS .....	3
2.2.2	MEANING OF THE CONSOLE LEDS .....	4
2.2.3	ERROR MESSAGES .....	4
<b>2.3</b>	<b>BUTTON AND LED FUNCTIONS IN THE IBM 9068 (4722) EMULATION</b> .....	<b>6</b>
2.3.1	BUTTON FUNCTIONS .....	6
2.3.2	LED INDICATIONS .....	6

<b>2.4</b>	<b>BUTTON AND LED FUNCTIONS IN THE SNI 4915 (4904) EMULATION .....</b>	<b>7</b>
2.4.1	BUTTON FUNCTIONS .....	7
2.4.2	LED INDICATIONS .....	7
<b>2.5</b>	<b>BUTTON AND LED FUNCTIONS IN THE IBM PROPRINTER II/X24 - EPSON LQ 2550 EMULATION .....</b>	<b>8</b>
2.5.1	BUTTON FUNCTIONS .....	8
2.5.2	LED INDICATIONS .....	8
<b>2.6</b>	<b>UPPER MECHANICAL ASSEMBLY LIFTING LEVER .....</b>	<b>9</b>
<b>3.</b>	<b>INSTALLATION .....</b>	<b>1</b>
<b>3.1</b>	<b>GENERAL INSTALLATION PRECAUTIONS .....</b>	<b>1</b>
3.1.1	ELECTRICAL POWER SUPPLY .....	1
3.1.2	ENVIRONMENTAL CONDITIONS .....	1
3.1.3	LOCATING THE MACHINE .....	1
<b>3.2</b>	<b>UNPACKING AND INSTALLING THE MACHINE .....</b>	<b>2</b>
3.2.1	UNPACKING THE MACHINE .....	2
3.2.2	INSTALLING THE MACHINE .....	4
<b>3.3</b>	<b>OFF-LINE TESTS .....</b>	<b>4</b>
3.3.1	STARTING AND STOPPING THE PRINT TEST .....	4
3.3.2	PRINT TEST CONTENTS .....	5
<b>3.4</b>	<b>CONNECTION TO THE SYSTEM .....</b>	<b>8</b>
3.4.1	RE 232C SERIAL INTERFACE (STANDARD) .....	8
3.4.2	OPTIONAL SERIAL INTERFACE + USB INTERFACE CARD .....	9
3.4.3	OPTIONAL IEEE 1284 PARALLEL INTERFACE CARD .....	11
<b>3.5</b>	<b>FINAL TESTING .....</b>	<b>13</b>
<b>3.6</b>	<b>INFORMATION FOR THE OPERATOR .....</b>	<b>13</b>
<b>3.7</b>	<b>OPERATING PROCEDURES .....</b>	<b>14</b>
3.7.1	INSERTING A DOCUMENT WITH AUTOMATIC ALIGNMENT .....	14
3.7.2	INSERTING A SAVINGS BOOK .....	15
3.7.3	INSERTING A CHECK FOR HORIZONTAL MAGNETIC DEVICE/MICR READ OPERATIONS .....	16
3.7.4	EXPULSION OF PROCESSED DOCUMENTS .....	17
3.7.5	REPLACING THE RIBBON CARTRIDGE .....	17
3.7.6	PAPER JAMS .....	20

<b>4. AUTODIAGNOSTICS, SET-UP AND ADJUSTMENTS .....</b>	<b>1</b>
<b>4.1 POWER-ON DIAGNOSTICS.....</b>	<b>1</b>
<b>4.2 PRINT TEST.....</b>	<b>2</b>
<b>4.3 PRINTER SET-UP .....</b>	<b>2</b>
4.3.1 ACTIVATING THE SET-UP .....	2
4.3.2 SUPPORT SOFTWARE .....	2
4.3.3 CONFIGURATION PARAMETERS .....	3
<b>4.4 SETTINGS .....</b>	<b>14</b>
4.4.1 PHOTOSENSOR CALIBRATION .....	14
4.4.2 BI-DIRECTIONAL PRINT ALIGNMENT CALIBRATION .....	20
4.4.3 TOP OF FORM (TOF) CALIBRATION.....	22
4.4.4 LEFT PRINT MARGIN CALIBRATION .....	24
4.4.5 DOCUMENT LENGTH MEASUREMENT .....	26
4.4.6 SKEW AND SIGNAL AMPLITUDE CONTROL .....	28
4.4.7 SIGNAL AMPLITUDE CONTROL .....	28
<b>5. PRODUCT DIAGNOSIS.....</b>	<b>1</b>
<b>5.1 SERVICING MODES.....</b>	<b>1</b>
5.1.1 FAULT DETECTION ANALYSIS .....	1
5.1.2 ANALYSIS OF THE OPERATING CONDITIONS .....	1
5.1.3 IDENTIFYING THE MALFUNCTION .....	2
5.1.4 FINDING THE CAUSE.....	2
5.1.5 SOLVING THE PROBLEM .....	2
5.1.6 TESTING THE MACHINE .....	2
<b>5.2 FAULT CLASSIFICATION.....</b>	<b>3</b>
<b>5.3 POWER ON FAULTS .....</b>	<b>4</b>
<b>5.4 DOCUMENT WRITE FAULTS .....</b>	<b>5</b>
<b>5.5 DOCUMENT HANDLING FAULTS .....</b>	<b>6</b>
<b>5.6 MAGNETIC STRIPE READ/WRITE FAILURES .....</b>	<b>7</b>

<b>6.</b>	<b>ELECTRICAL INTERCONNECTIONS .....</b>	<b>1</b>
6.1	<b>GENERAL PRINTER INTERCONNECTION DIAGRAM .....</b>	<b>1</b>
6.2	<b>BAPR2 MAIN BOARD .....</b>	<b>2</b>
	6.2.1 MAIN BOARD VIEW AND LOCATION OF CONNECTORS .....	2
	6.2.3 CONNECTOR PIN-OUT .....	3
6.3	<b>MAGNETIC OPTIONS CARD .....</b>	<b>5</b>
	6.3.1 CARD LOCATION AND IDENTIFICATION OF CONNECTORS .....	5
	6.3.2 VIEW OF THE PR2MAGN CARD .....	6
6.4	<b>SERIAL AND USB INTERFACE CARD .....</b>	<b>8</b>
	6.4.1 CARD VIEW AND LOCATION OF CONNECTORS .....	8
	6.4.2 CONNECTOR PIN-OUT .....	9
6.5	<b>PARALLEL INTERFACE CARD .....</b>	<b>10</b>
	6.5.1 CARD VIEW AND LOCATION OF CONNECTORS .....	10
	6.5.2 CONNECTOR PIN-OUT .....	11
6.6	<b>CONSOLE .....</b>	<b>12</b>
6.7	<b>ALIPR2E CARD .....</b>	<b>13</b>
	6.7.1 CARD VIEW AND LOCATION OF CONNECTORS .....	13
	6.7.2 CONNECTOR PIN-OUT AND FUSE .....	13
<b>7.</b>	<b>PREVENTIVE MAINTENANCE .....</b>	<b>1</b>
7.1	<b>CLEANING .....</b>	<b>1</b>
	7.1.1 CLEANING THE CASE .....	1
	7.1.2 CLEANING THE PAPER PATHS .....	1
	7.1.3 CLEANING THE MAGNETIC READ HEAD .....	1
7.2	<b>MAINTENANCE .....</b>	<b>2</b>
7.3	<b>LUBRICATION .....</b>	<b>3</b>
	7.3.1 LUBRICATION POINTS ON THE BASIC MACHINE .....	3
	7.3.2 HORIZONTAL MAGNETIC DEVICE/MICR LUBRICATION POINTS .....	4



<b>8.</b>	<b>MECHANICAL ADJUSTMENTS .....</b>	<b>1</b>
8.1	<i>DOCUMENT FEED BELT ADJUSTMENT.....</i>	<i>2</i>
8.2	<i>PRINT BAR ADJUSTMENT .....</i>	<i>3</i>
8.3	<i>PARALLELISM ADJUSTMENT BETWEEN THE PRINT BAR AND LEAF .....</i> <i>SPRING LOAD IN THE BASIC MACHINE .....</i>	<i>4</i>
8.4	<i>TAB ADJUSTMENT .....</i>	<i>5</i>
8.5	<i>FRONT TAB OPENING CHECK .....</i>	<i>6</i>
8.6	<i>ROLLER GEAR ADJUSTMENT .....</i>	<i>7</i>
8.7	<i>FRONT PRESSURE ROLLER ADJUSTMENT .....</i>	<i>8</i>
8.8	<i>TAB OPENING ADJUSTMENT .....</i>	<i>9</i>
8.9	<i>HORIZONTAL MAGNETIC DEVICE/MICR OPTION CARRIAGE FEED BELT ...</i> <i>TENSION ADJUSTMENT .....</i>	<i>10</i>
8.10	<i>HORIZONTAL MAGNETIC DEVICE/MICR DOOR ADJUSTMENT.....</i>	<i>11</i>
8.11	<i>HORIZONTAL MAGNETIC DEVICE/MICR PRESS POSITIONING .....</i>	<i>12</i>
8.12	<i>POSITIONING THE ASSEMBLY ON THE HORIZONTAL MAGNETIC</i> <i>DEVICE/MICR.....</i>	<i>13</i>
<b>9.</b>	<b>DISASSEMBLY/REASSEMBLY PROCEDURES .....</b>	<b>1</b>
9.1	<i>GENERAL DISASSEMBLY/REASSEMBLY PRECAUTIONS .....</i>	<i>2</i>
9.2	<i>DISASSEMBLY/REASSEMBLY OF THE BASIC MACHINE .....</i>	<i>3</i>
9.2.1	<i>CASE DISASSEMBLY/REASSEMBLY .....</i>	<i>3</i>
9.2.2	<i>CONSOLE DISASSEMBLY/REASSEMBLY .....</i>	<i>4</i>
9.2.3	<i>MECHANICAL ASSEMBLY DISASSEMBLY/REASSEMBLY .....</i>	<i>5</i>
9.2.4	<i>PRINTHEAD FLAT CABLE DISASSEMBLY/REASSEMBLY .....</i>	<i>6</i>
9.2.5	<i>PRINTHEAD DISASSEMBLY/REASSEMBLY .....</i>	<i>8</i>
9.2.6	<i>PRINTHEAD PHOTODIODE DISASSEMBLY/REASSEMBLY .....</i>	<i>9</i>
9.2.7	<i>SUPPER PART OF THE MECHANICAL ASSEMBLY</i> <i>DISASSEMBLY/REASSEMBLY .....</i>	<i>10</i>
9.2.8	<i>PAPER FEED MOTOR DISASSEMBLY/REASSEMBLY .....</i>	<i>11</i>
9.2.9	<i>PRINTHEAD MOVEMENT MOTOR DISASSEMBLY/REASSEMBLY .....</i>	<i>12</i>
9.2.10	<i>CARRIAGE RESET PHOTODIODE DISASSEMBLY/REASSEMBLY .....</i>	<i>13</i>

9.2.11	ROLLER SUPPORT TRAY DISASSEMBLY/REASSEMBLY .....	14
9.2.12	SERVICES MOTOR DISASSEMBLY/REASSEMBLY .....	15
9.2.13	FEEDER PHOTOSENSORS DISASSEMBLY/REASSEMBLY .....	16
9.2.14	PRINT BAR DISASSEMBLY/REASSEMBLY .....	19
9.2.15	MAIN BOARD DISASSEMBLY/REASSEMBLY .....	20
9.2.16	POWER SUPPLY ASSY DISASSEMBLY/REASSEMBLY .....	21
<b>9.3</b>	<b>BASIC MACHINE OPTIONS DISASSEMBLY/REASSEMBLY .....</b>	<b>22</b>
9.3.1	HORIZONTAL MAGNETIC DEVICE/MICR DISASSEMBLY/REASSEMBLY .	22
9.3.2	HORIZONTAL MAGNETIC DEVICE/MICR MOTOR DISASSEMBLY/REASSEMBLY .....	23
9.3.3	HORIZONTAL MAGNETIC DEVICE/MICR HEAD ASSY DISASSEMBLY/REASSEMBLY .....	24

# 1. PRODUCT OVERVIEW

## 1.1 INTRODUCTION

The PR2 E is a specialized mid-range banking printer. It can handle ordinary stationary (single and multicopy forms) and savings books for deposit/withdrawal transactions.

Very versatile, this printer can also be used in Public Administration front-office environments and in Post offices. It can be equipped with a horizontal magnetic device for reading/writing horizontal magnetic bands, or with a horizontal magnetic device and MICR (Magnetic Ink Character Reader) reader for reading the code lines printed on checks. This printer model can also be configured with different interfaces and emulations.

The PR2 Enhanced represents the evolution in terms of quality and performance of the PR2, to which it maintains complete compatibility as far as the firmware and accessories are concerned.

With respect to the PR2, the PR2 E carries the following significant differences:

- Updated design
- Improved printing speed
- Interchangeable communication ports thanks to the possibility of installing supplementary snap-in interface cards
- Availability of support software for on-line setup, the design and loading of user character fonts, design and storage of a user logo and the on-line loading of character generators
- 100 to 130 and 200 to 240 VAC  $\pm$  10% switching power supply unit
- Optional fan for delaying the activation of the thermal protection when printing complex graphics
- Dual-interface functionality in all emulations
- IBM 9068 and IBM X24 emulations.

### 1.1.1 PR2 E FACTORY CONFIGURATION

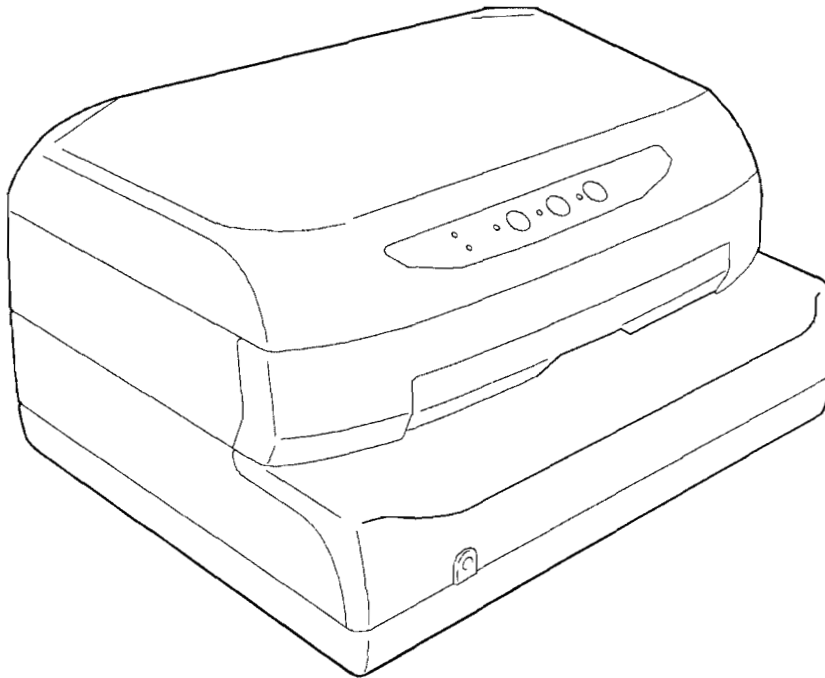
The following table indicates the different PR2 E factory configurations:

<b>Commercial Name</b>	<b>Serial Interface</b>	<b>Serial/Parallel Interface</b>	<b>Double Serial Interface</b>	<b>Horizontal Magnetic Device</b>	<b>MICR Reader</b>
PR2 E S10	X				
PR2 E D10		X			
PR2 E D12		X		X	
PR2 E D12 M		X			X
PR2 E D10 DSP			X		
PR2 E S12	X			X	
PR2 E S12 M	X				X

## 1.2 GENERAL MACHINE CHARACTERISTICS

PRINTING MODULE	Dot-matrix printhead with 24 diamond-shaped needles and overtemperature protection Printing capability: 1 original + 4 copies Savings book handling features
PRINTING SPEED	86 cps @ 10 cpi in LQ 130 cps @ 10 cpi in NLQ 260 cps @ 10 cpi in DRAFT 350 cps @ 10 cpi in HSD
PRINT QUALITY	H.S.D., DRAFT, N.L.Q., L.Q.
RIBBON CARTRIDGE	Indelible fabric, with a life span of 3.5 M characters
PAPER FEED	Front feeder with automatic document alignment. If the magnetic device is present, the savings book must be aligned manually. The machine will generate an error message.
PAPER SIZE	245 x 450 mm max. 70 x 65 mm min. For more information refer to section 1.5.
CONSOLE	Located on the printer cover, it has three buttons and five LEDs
EMULATIONS	PR40+, PR2 E and IBM PP II, X24, SNI 4915, IBM 9068
INTERFACE	Standard RS 232C serial with the possibility of installing the following interface cards: - RS 232C serial + USB - Centronics parallel.
DIMENSIONS	Width: 384 mm Depth: 280 mm Height: 195 mm Weight: 10.5 Kg.
POWER CONSUMPTION	Stand-by: $\leq 15$ W During operation: 170 W max (worst case)
POWER SUPPLY	Switching power supply: 100 to 130 VAC $\pm 10\%$ 200 to 240 VAC $\pm 10\%$

The following figure gives an overall view of the printer.



*Fig. 1-1 PR2 E Printer*

### **1.3 HORIZONTAL MAGNETIC DEVICE/MICR FEATURES**

The Horizontal magnetic device/MICR (Magnetic Ink Character Recognition) device reads characters printed on checks with magnetic ink. Horizontal magnetic device/MICR applications are compatible with the CMC7 and E13B standards.

**CMC7:** This standard uses a coding technique similar to bar codes. In this case the character consists of seven black bars of equal width and spaced by four narrow gaps and two wide gaps.

**E13B:** In this case the characters are continuous (not bars) and have a precise shape. The magnetic reader must also interpret the amplitude of the wave form and therefore not only its variation in time.

## 1.4 PRODUCT VARIABLES

VOLTAGE AND FREQUENCY    TEN 023    110/120V 50/60 Hz  
                                  TEN 204    220/240V 50/60 Hz

POWER CORD                    COR 005    Europe  
                                  COR 041    Switzerland  
                                  COR 042    Great Britain  
                                  COR 043    Australia  
                                  COR 050    USA  
                                  COR 080    South Africa

CRT FIRMWARE                Olivetti standard + IBM X24  
                                  IBM 9068 + IBM X24  
                                  SNI 4915 + EPSON LQ 2550

## 1.5 DOCUMENTS HANDLED BY THE BASIC MACHINE

### 1.5.1 SINGLE AND MULTI-COPY FORMS

Maximum width	245 mm
Minimum width	65 mm
Maximum recommended length	297 mm
Maximum accepted length	450 mm
Minimum length	70 mm
Single sheet weight	60 to 160 g/m <sup>2</sup>
Single sheet thickness	0.1 to 0.28 mm
Transparency	Up to 25% and uniform
Multicopy weight (chemical)	40 to 60 g/m <sup>2</sup>
Carbon paper weight	20 to 34 g/m <sup>2</sup>
Maximum printable copies with chemical paper	1+5 with average paper weight and in the NLQ/LQ print mode
Maximum printable copies with carbon paper	1+4 with average paper weight and in the NLQ/LQ print mode
Recommended weight	Original 50 g/m <sup>2</sup> , last copy 60 g/m <sup>2</sup>
Multicopy glueing	At head or on the side
Maximum weight of multicopy forms	320 g/m <sup>2</sup>
Print quality (with multicopy forms)	NLQ or LQ



## 1.5.2 SAVINGS BOOKS

Max. thickness with book open	1.8 mm
Max. difference in level between pages	1.2 mm
Cover thickness	0.2 to 0.5 mm
Type of binding	Thread-sewn, without metal staples or clips
Book preparation	Must be carefully flattened before being inserted into the machine
<i><u>Book with Vertical Seam</u></i>	
Open book width	241.3 mm/9.5" max.; 150 mm/5.9" min.
Maximum length	220 mm
Minimum length	85 mm
Union of external corners	3 to 14 mm radius
<i><u>Book with Horizontal Seam</u></i>	
Open book width	241.3 mm/9.5" max.; 150 mm/5.9" min.
Maximum length	220 mm
Minimum length	165 mm

## 1.6 ACCESSORIES

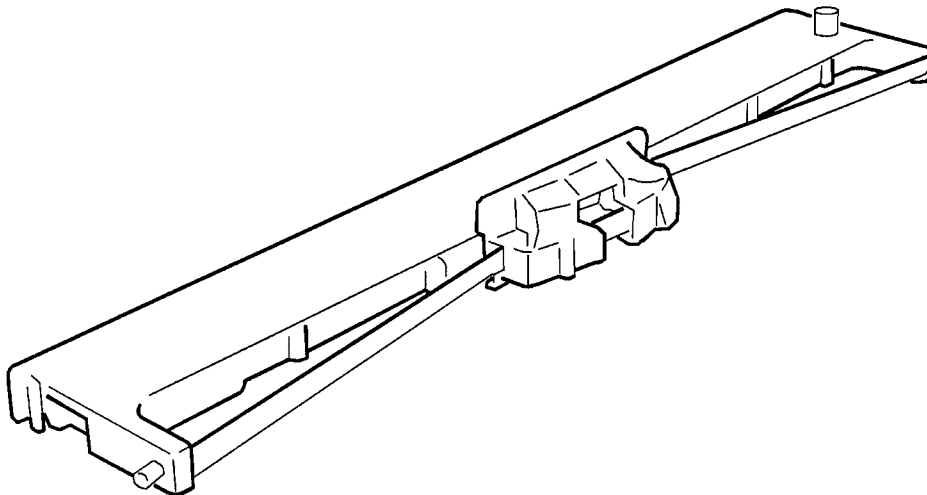
This section describes the accessories available for the PR2 E printer.

### ***BLACK NYLON SNUG CART RIBBON CARTRIDGE***

Ribbon cartridge specific for the needle printhead, with a life-span of more than 3.5 million characters. The cartridge is installed in the machine by opening the printer cover, with automatic printhead positioning if the printer is powered on or manual positioning if powered off, and lifting the print assembly by using the appropriate lever.

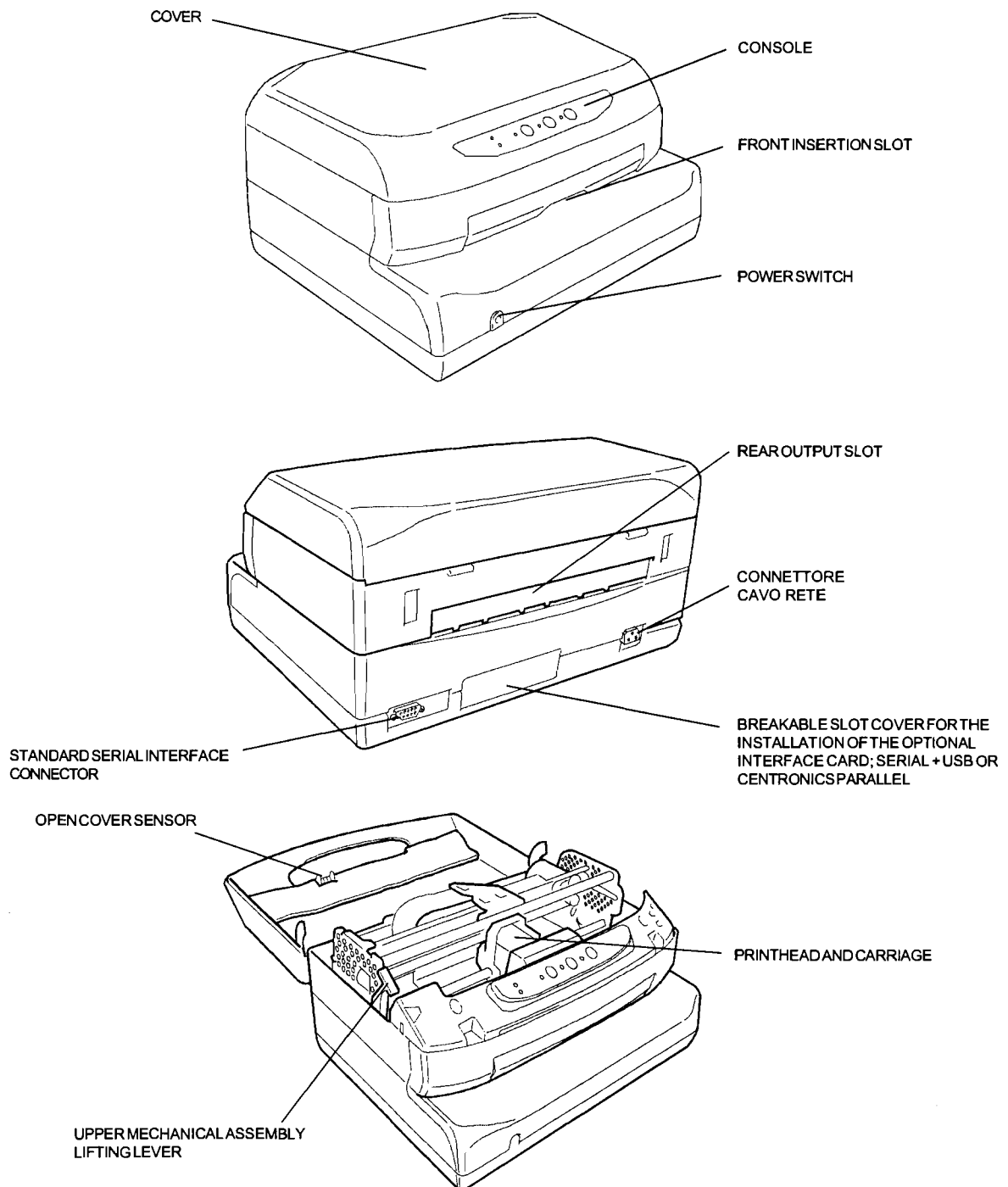
### ***INDELIBLE NYLON SNUG CART RIBBON CARTRIDGE***

The same as the BLACK NYLON SNUG CART but with indelible ink.



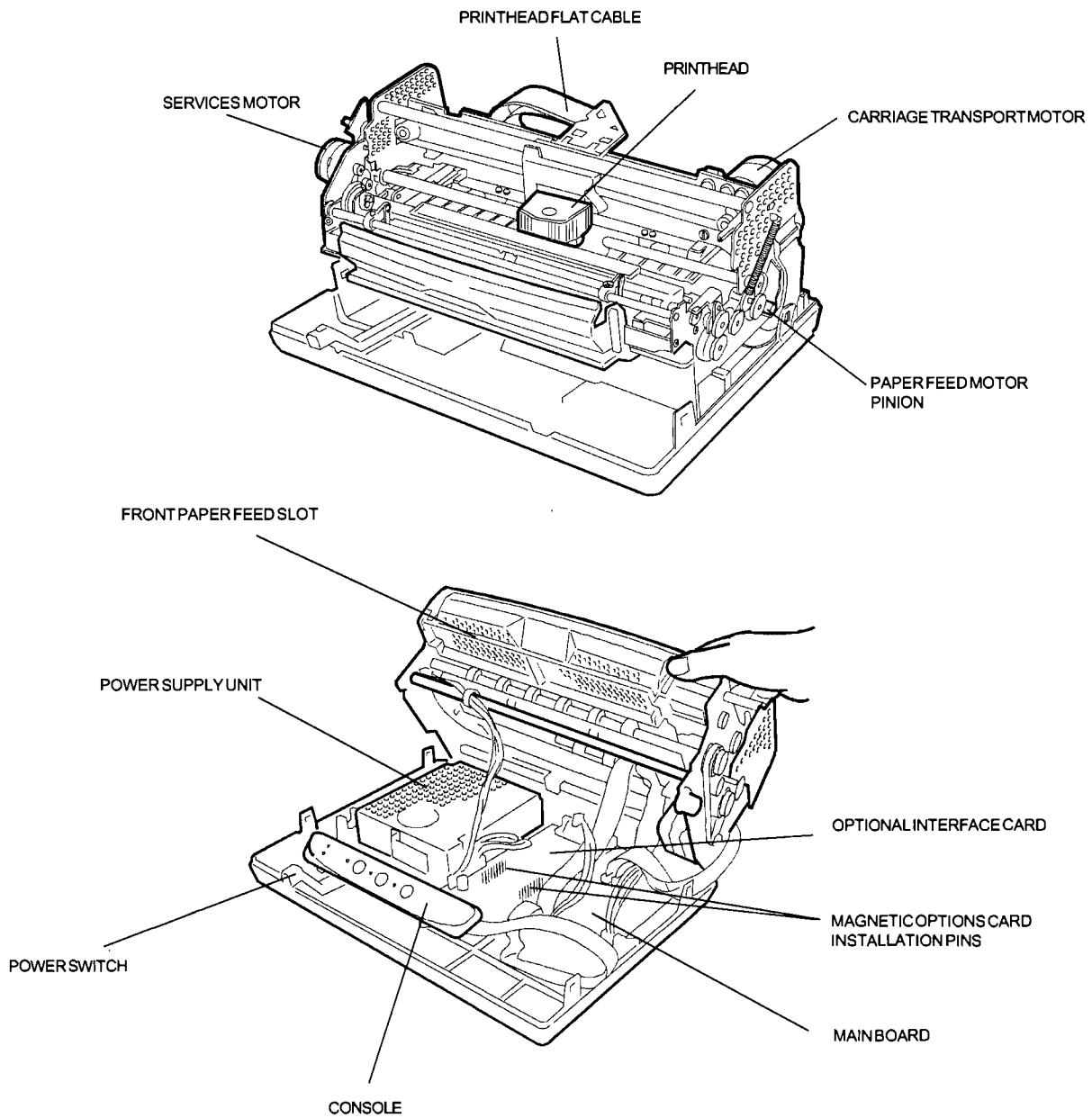
*Fig. 1-2 SNUG CART Ribbon Cartridge*

## 1.7 LOCATING THE PRINTER'S MAJOR COMPONENTS



*Fig. 1-3 Locating the Printer's Major Components*

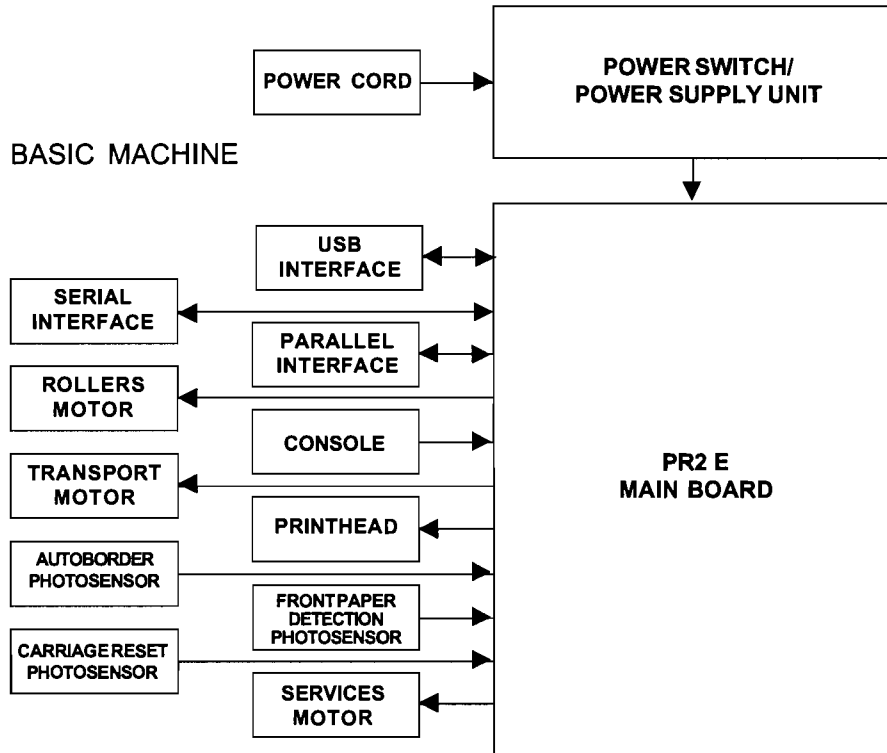
## 1.8 LOCATING THE PRINTER'S MAJOR INTERNAL COMPONENTS



*Fig. 1-4 Locating the Printer's Major Internal Components*

## 1.9 GENERAL BLOCK DIAGRAM

### 1.9.1 BASIC MACHINE



## 1.10 FIRMWARE AND CHARACTER GENERATORS

### 1.10.1 MACHINE FIRMWARE

Separate from the character generator and character set, the printer management firmware is independently managed during the uploading operations so that all access to the character area for modification is rendered more flexible and immediate.

The printer's basic memory is provided by a 1 MB Flash EPROM. The management FW, the character generators and character sets reside in this memory and can be replaced on-line.

A second Flash EPROM (optional) of the same capacity and capable of hosting complex character sets and considerable macro and logo volumes, can be installed on the main board.

The machine firmware includes the following emulations:

- Olivetti environment: STD 12/14 controlled protocol with the PR2 E native environment, PR40+ and PR2845 emulation. IBM Proprinter II and Proprinter X24 industry-standard emulation.
- IBM environment: 9068 protocol emulation covering also the model 4722. IBM Proprinter II and Proprinter X24 industry-standard emulation.
- Wincor-Nixdorf environment: SNI 4915 protocol emulation covering also the models 4905. EPSON LQ 2550 industry-standard emulation.

### 1.10.2 CHARACTER SETS

Compatibility at system level for each character set is extended to the environments listed below:

ENVIRONMENT	CHARACTER SETS
PC/DOS	CP SET, CODE PAGE
WINDOWS 2.X, 3.0; OS/2; UNIX	ISO 8859/X
WINDOWS 3.1	CP SET
OLIVETTI	STD 15

Each emulation in the machine has one or more associated character sets. The character sets that are available with each emulation are listed in the following table:

EMULATION	CHARACTER SETS
OLIVETTI	CP SET, STD 15 Olivetti, ISO
IBM	CP SET, ISO

### 1.10.3 PRINT MODES AND CHARACTER FONTS

The following table indicates the characteristics of the different print modes:

	10 cpi	12 cpi	15 cpi
- H.S.D. (High Speed Draft)	350 cps	314 cps	327 cps
- DRAFT	260 cps	260 cps	260 cps
- N.L.Q. (Near Letter Quality)	130 cps	130 cps	130 cps
- L.Q. (Letter Quality)	86 cps	104 cps	131 cps

The reference standards for the optical characters are the following:

Font	Code Standard	Std. Dimensions/Shape	Print Specifications
OCR A	EUROBANKING	ISO 1073/1	ISO 1831
OCR B	EUROBANKING	ISO 1073/2	ISO 1831

Relationship between write cycles and emulation environment:

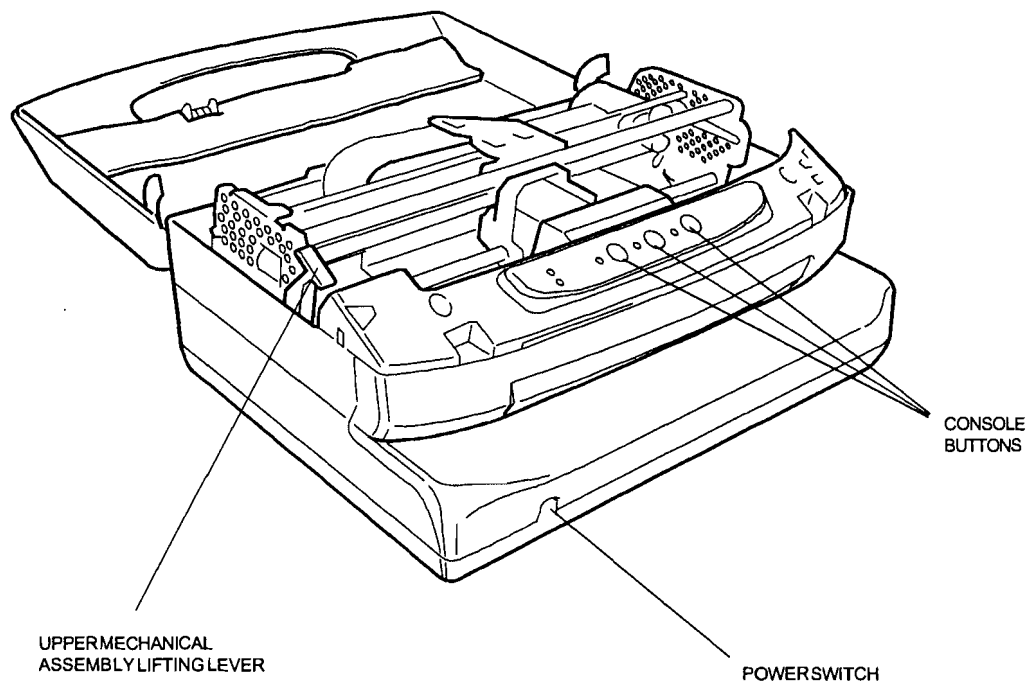
Emulation	Print Styles	Selection
PR50/PR2845	HSD, DRAFT, NLQ1, NLQ2, LQ2, OCRA, OCRB	FROM SET-UP
	DRAFT, NLQ1	FROM THE LINE
PR50/PR40+	HSD, DRAFT, NLQ1, NLQ2, LQ2, OCRA, OCRB	FROM SET-UP
	DRAFT, NLQ1, OCRA, OCRB	FROM THE LINE
PR2 E	HSD, DRAFT, NLQ1, NLQ2, LQ2, OCRA, OCRB	FROM SET-UP
	HSD, DRAFT, NLQ1, NLQ2, LQ2, OCRA, OCRB, ITALICO DRAFT ITALICO NLQ1, ITALICO NLQ2, ITALICO LQ2	FROM THE LINE
IBM PP II/X24	HSD, DRAFT, NLQ1, NLQ2, LQ2	FROM SET-UP
	DRAFT, NLQ1	FROM THE LINE



## 2. OPERATING COMMANDS

The machine's operating commands are the following:

- power switch
- console buttons
- upper mechanical assembly lifting lever.



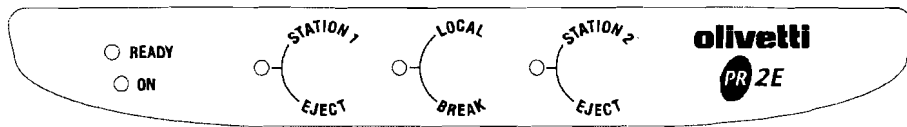
*Fig. 2-1 Operating Commands*

## 2.1 POWER SWITCH

The printer is equipped with a two-pole power switch. The switch on/off command is provided by means of a rod that crosses the printer longitudinally.

## 2.2 CONSOLE

The printer console has five LEDs and three buttons.



*Fig. 2-2 Console*

The console is also equipped with a circuit breaker (Dry-reed) that informs the board logics when the printer's top cover is opened.

During the machine set-up (section 4.3) or adjustment (section 4.4) phases, the buttons perform different functions according to the procedures in which they are used.

## 2.2.1 FUNCTIONS OF THE CONSOLE BUTTONS

The buttons on the console perform the following functions:

- STATION 1:** Reserves operator 1 (Olivetti STD 12/14) or assigns the printer to operator 1 (\*)
- STATION 2:** Reserves operator 2 (Olivetti STD 12/14) or assigns the printer to operator 2 (\*)
- LOCAL/BREAK:** Toggles the printer between the on-line and off-line states
- EJECT (ST. 1):** Ejects the paper of operator 1 or ejects the paper present (\*)
- EJECT (ST. 2):** Ejects the paper of operator 2 (\*)

(\*) According to the selected emulation.

You can access the different machine states by powering on or resetting the printer while holding down one or more buttons. The buttons assume different functions depending on whether the printer top cover is opened or when the printer is powered on or reset while holding down determined console buttons.

The following table provides the meaning of the console buttons in both cases.

Local	ST. 1	ST. 2	Cover open	MACHINE STATE
		X		Print test
	X	X		Set-up
	X		X	Clear paper jam procedure
X	X		X	Printer set for the on-line updating of the firmware (onto Flash-EPROM)
X	X	X	X	Access to the following procedures: a) Photosensor adjustment b) User TOF setting c) Left-hand margin setting d) Paper or savings book length measurement e) Print alignment adjustment f) Photosensor adjustment printout
X			X	Disable cover open signal

## 2.2.2 MEANING OF THE CONSOLE LEDS

When on, the LEDs inform of the following machine states:

- ON:** Machine powered on
- READY:** Printer on-line/in receive mode or document present (\*)
- LOCAL:** Machine in LOCAL (off-line)
- STATION 1:** *When on:* Waiting for a document from operator 1 (Oliveti STD 12/14) or machine assigned to operator 1 or document present (\*)  
*When flashing:* Waiting for a document from operator 1 or data present in the buffer (\*)
- STATION 2:** *When on:* Waiting for a document from operator 2 (Oliveti STD 12/14) or machine assigned to operator 2 or document present (\*)  
*When flashing:* Waiting for a document from operator 2

(\*) According to the selected emulation.

## 2.2.3 ERROR MESSAGES

The table on the next page shows the different LED configurations (with the exception of the ON LED which is always on) and their meaning.

The faults are classified as follows:

- (1) Fatal error. This error locks the machine and can only be cleared by powering off the printer and proceeding with all necessary repairs.
- (2) Operator-correctable error (paper jam) that can be cleared by removing the cause and then pressing the ST1 key with the cover open.

### 2.2.3.1 FAULT IDENTIFICATION CHART

FAULT \ LED	ON	READY	ST1	LOCAL	ST2
Power supply unit failure	OFF	OFF	OFF	OFF	OFF
On-board failure: - Eprom - ROM - Microprocessor	ON	OFF	OFF	OFF	OFF
Failure caused by: - Fuse - Driver - Motors	ON	ON	ON	ON	ON
Activation board failure	The motors are not working				

## **2.3 BUTTON AND LED FUNCTIONS IN THE IBM 9068 (4722) EMULATION**

This section describes the button functions and LED indications of the PR2 E printer when in the IBM 4722 emulation.

### **2.3.1 BUTTON FUNCTIONS**

The buttons have the following functions:

LOCAL/BREAK      Toggles the printer between the on-line and off-line states.

STATION 1/EJECT    Assigns the printer to operator 1. SW-monitored button.

STATION 2/EJECT    Assigns the printer to operator 2. SW-monitored button.

Pressing the STATION 2/EJECT button while powering on the printer prints the self-test.

### **2.3.2 LED INDICATIONS**

When on, the LEDs inform of the following machine states:

ON                  Green LED, indicates that the machine is powered on.

READY              Yellow LED, indicates that the printer is on-line and that a document is present.

LOCAL              Yellow LED, indicates that the printer is off-line.

STATION 1          Yellow LED, indicates that the printer is assigned to operator 1.

STATION 2          Yellow LED, indicates that the printer is assigned to operator 2.

Since the buttons and LEDs are managed via SW, their functions and usage may vary according to the application SW being used.

## 2.4 BUTTON AND LED FUNCTIONS IN THE SNI 4915 (4904) EMULATION

This section describes the button functions and LED indications of the PR2 E printer when in the SNI 4915 (4904) emulation.

### 2.4.1 BUTTON FUNCTIONS

The buttons have the following functions:

- LOCAL/BREAK       Toggles the printer between the on-line and off-line states
- STATION 1/EJECT   Assigns the printer to operator 1 and ejects the document of operator 1.
- STATION 2/EJECT   Assigns the printer to operator 2 and ejects the document of operator 2.

Pressing the STATION 2/EJECT button while powering on the printer prints the self-test.

### 2.4.2 LED INDICATIONS

When on, the LEDs inform of the following machine states:

- ON               Green LED, indicates that the machine is powered on.
- READY           Yellow LED, indicates that the printer is on-line.
- LOCAL           Yellow LED, indicates that the printer is off-line.
- STATION 1       Yellow LED; when flashing indicates that the printer is waiting for a document from operator 1, when on indicates that a document is present.
- STATION 2       Yellow LED; when flashing indicates that the printer is waiting for a document from operator 2, when on indicates that a document is present.

A specific console different than the one used on the standard product is available for this PR2 E version.

## **2.5 BUTTON AND LED FUNCTIONS IN THE IBM PROPRINTER II/X24 - EPSON LQ 2550 EMULATION**

This section describes the button functions and LED indications of the PR2 E printer when in the IBM Proprinter II/X24, EPSON LQ 2550 emulation.

### **2.5.1 BUTTON FUNCTIONS**

The buttons have the following functions:

LOCAL/BREAK      Toggles the printer between the on-line and off-line states

STATION 1/EJECT    Ejects the document present.

STATION 2/EJECT    Not used.

Pressing the STATION 2/EJECT button while powering on the printer prints the self-test.

### **2.5.2 LED INDICATIONS**

When on, the LEDs inform of the following machine states:

ON                  Green LED, indicates that the machine is powered on.

READY              Yellow LED, indicates that the printer is on-line.

LOCAL              Yellow LED, indicates that the printer is off-line.

STATION 1    Yellow LED; when flashing indicates that data are present in the buffer, when on indicates that a document is present.

STATION 2    No indication.

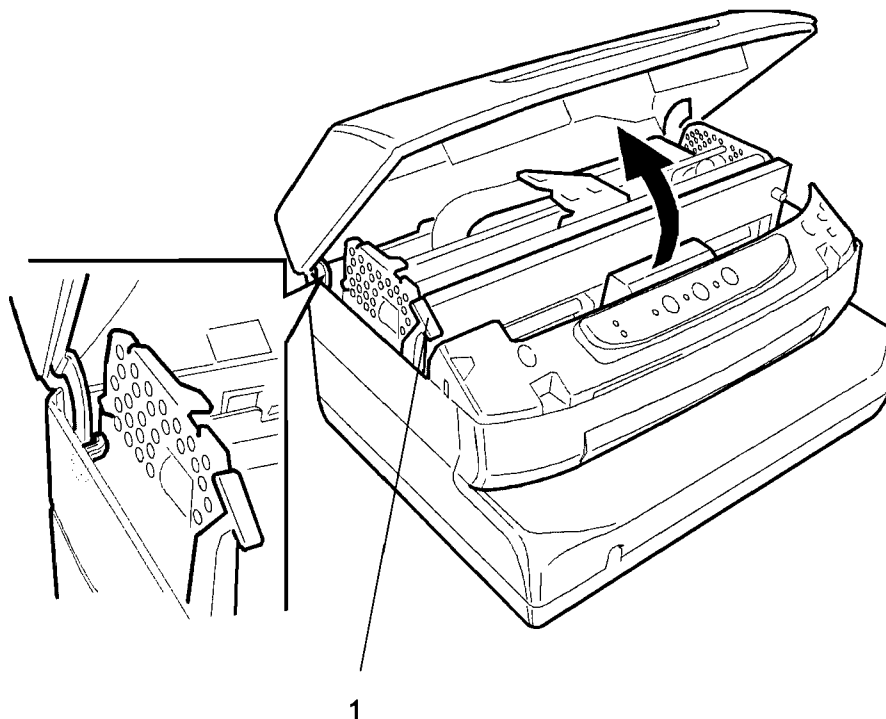
A specific console different than the one used on the standard product is available for this PR2 E version.



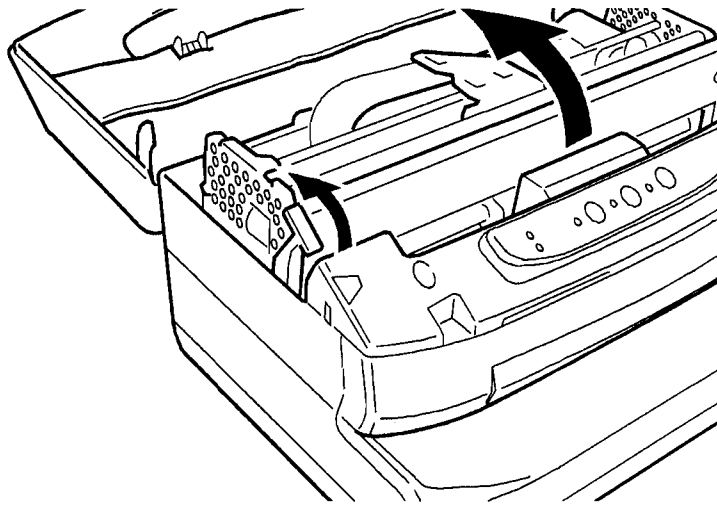
## 2.6 UPPER MECHANICAL ASSEMBLY LIFTING LEVER

The upper mechanical assembly lifting lever (1) is located on the left-hand side of the printer and is used to lift the upper part of the mechanical assembly so that you can access the internal paper path so that paper jams can be cleared without needing to power off the printer.

To access this lever, lift the printer cover about 45 degrees until it stops.

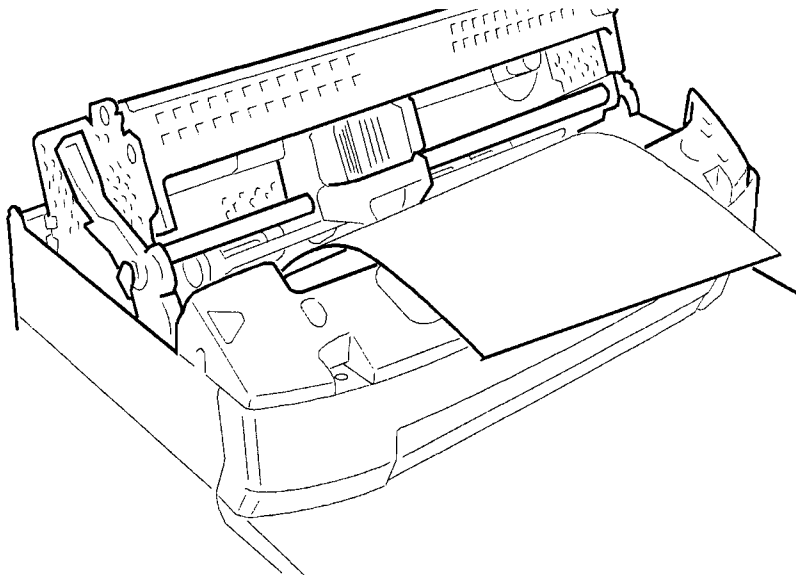


*Fig. 2-3 Opening the Cover*



*Fig. 2-4 Upper Mechanical Assembly Lifting Lever*

Pushing this lever as far as it goes lifts the upper part of the mechanical assembly thus granting you access to the paper path.



*Fig. 2-5 Removing a Jammed Sheet of Paper*

## **3. INSTALLATION**

### **3.1 GENERAL INSTALLATION PRECAUTIONS**

To ensure optimum printer functionality and to avoid making service calls for problems that are not directly caused by the product itself, bear in mind the information provided in the following sections.

#### **3.1.1 ELECTRICAL POWER SUPPLY**

Make sure that the electrical wall outlet to which the printer is connected has a valid ground and that it is able to supply the power needed by the machine. A wall outlet without ground can cause functional problems and can be a safety hazard.

Do not plug the printer to electrical wall outlets that are already being used by equipment that could cause electrical noise and excessive voltage fluctuations (fans and air conditioners, large photocopiers, lift motors, TV radio transmitters and signal generators, high frequency safety devices, and so on).

Common office equipment (calculating machines, typewriters, small photocopiers, terminals and personal computers) can share the same outlet as long as they do not cause excessive electrical noise.

#### **3.1.2 ENVIRONMENTAL CONDITIONS**

The environmental conditions in which the product can remain for an indefinite period of time are indicated by the AB quality objectives referring to a normal climatized office environment (environmental temperature of 15/35 °C, relative humidity of 15/85%).

During machine storage and operation, make sure that condensation does not form as the result of extreme environmental variations. Dust, dirt and smoke can cause the parts in motion to wear excessively, short circuits (in the presence of a high degree of humidity) and read/write errors during operation. High temperatures and low humidity can cause problems due to static electricity.

#### **3.1.3 LOCATING THE MACHINE**

The printer must be installed on a flat, vibration-free surface.

Do not position the machine near air conditioning systems, heat sources or in direct sunlight.

Do not obstruct the printer's ventilation slots.

If the printer is installed in a cabinet, make sure that it has good ventilation so as to avoid overheating.

Install the printer in a position so that paper jams can be cleared easily.

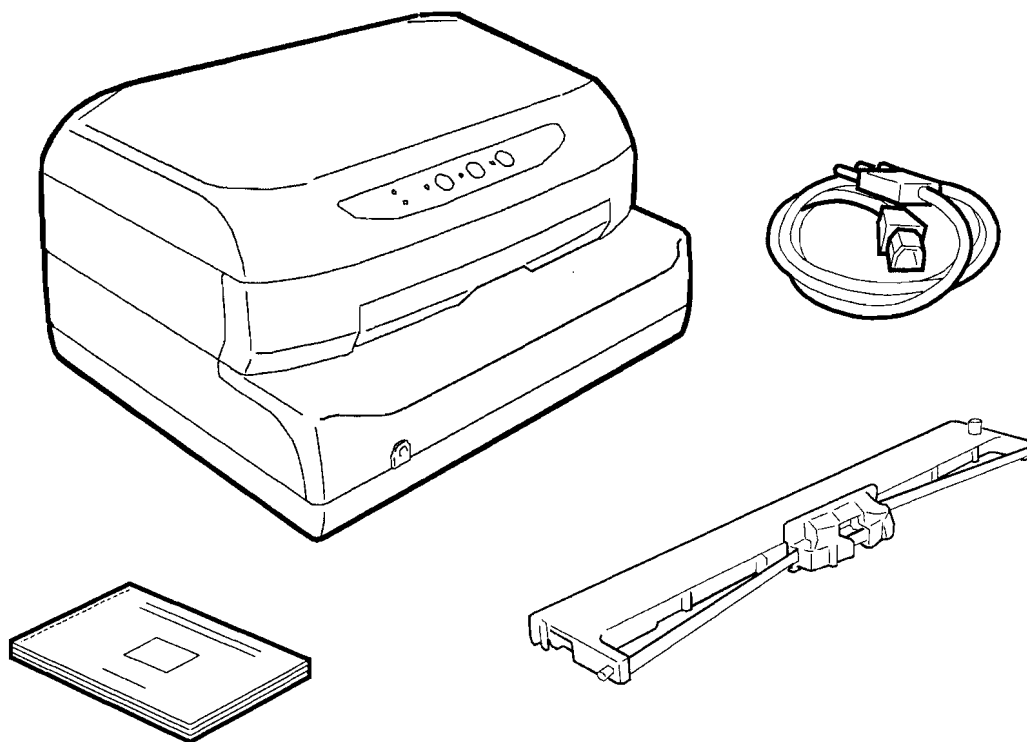
## 3.2 UNPACKING AND INSTALLING THE MACHINE

### 3.2.1 UNPACKING THE MACHINE

#### *Checking the box contents*

The following items should be contained in the packaging:

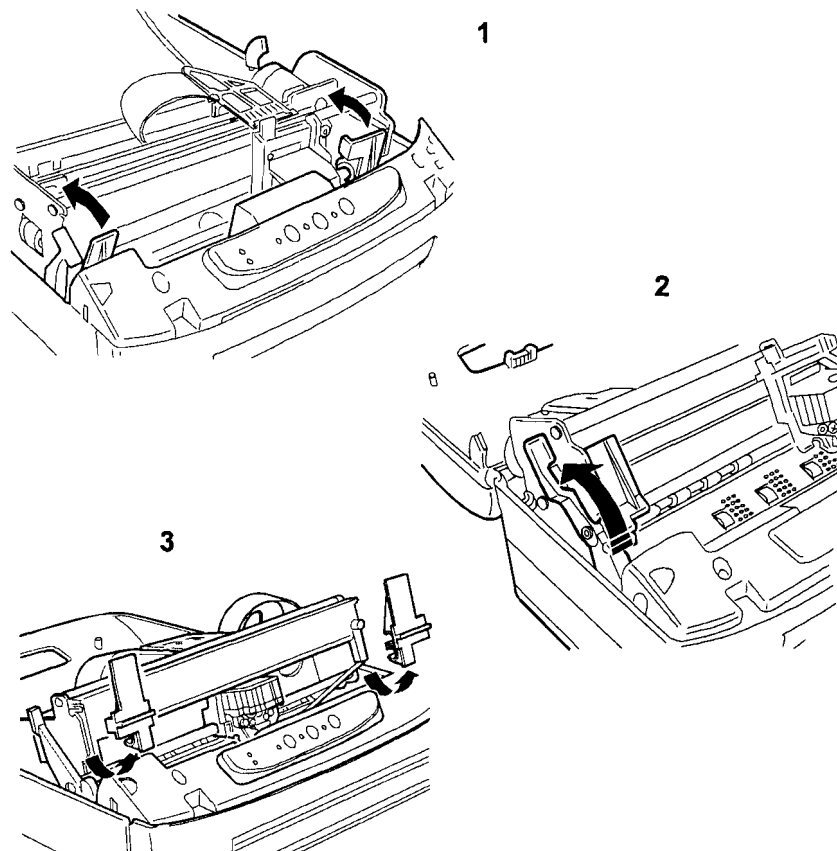
- PR2 E printer
- Power cord
- Operator Manual
- Ribbon cartridge
- Magnetic head cleaning card (not shown in the figure below) for models equipped with this option.



*Fig. 3-1 Package Contents*

### ***Unpacking and Setting-Up the Printer***

- Remove the machine from its protective bag.
- Open the printer's top cover completely, forcing it to a horizontal position.
- Push forward the two red plastic retainers that lock the print carriage (illustration 1 in the following figure).
- Lift the upper part of the mechanical assembly (illustration 2 in the following figure) and then remove the two retainers (illustration 3 in the following figure).



*Fig. 3-2 Removing the Transportation Retainers*

- Quickly check that the printer was not damaged during transportation.
- Install the ribbon cartridge (section 3.7.5)
- Close the machine.

### **3.2.2 INSTALLING THE MACHINE**

Position the machine for operation, making sure that it complies with the information provided in section 3.1.

Make sure that the voltage rating indicated on the electrical data plate corresponds to the local mains. Plug the power cord into the electrical wall outlet and then power on the printer.

Make sure that the printer powers on by checking the mechanical reset and the lighting of the ON LED on the console.

If other LEDs other than the ON LED remain lit, refer to section 2.2.3 "Error Messages".

### **3.3 OFF-LINE TESTS**

A print test can be run to make sure that the printer works correctly before actually connecting it to the system.

#### **3.3.1 STARTING AND STOPPING THE PRINT TEST**

Proceed as follows to activate the print test:

- Power off the printer.
- Power on the printer while pressing the STATION 2/EJECT button on the console.
- After printer initialization, insert an A4 sheet of paper into the front feed slot until triggering the paper alignment photosensor.

The machine will automatically feed the sheet of paper and start printing the test. The sheet of paper is automatically expelled at the end of the test. To repeat the test simply insert a new sheet of paper.

To stop the print test, power off the machine.

### 3.3.2 PRINT TEST CONTENTS

The print test provides the following information:

- The release and version of the firmware and character generators installed
- A graphical representation of 24-needle functionality (Needles test)
- The configuration of the printer
- The parameters defined for the IBM-PP and Olivetti emulations.

To stop the print test, power off the printer.

The following pages provide examples (Fig. 3-3 and Fig. 3-4) of the information provided by the tests. The content of the test depends on the FW release installed on the printer.

Needles test:

1	2	3	4	5	6	7	8	9	0	1	1	1	1	1	1	1	1	1	1	2	2	2	2	2	0	E
																									D	V

CONFIG.

DRAFT SPEED: NORMAL  
 LQ TYPE: NLQ1  
 PAPER WIDTH: FIRST LINE  
 BUZZER: Y  
 INTERFACE: DUAL  
 RS1 EMULATION: OLIVETTI  
 BAUD RATE: 9600  
 BIT/CHAR: 8  
 PARITY: NONE  
 STOP BIT: 1  
 DSR: Y  
 DCD: Y  
 CX EMULATION: IBM  
 STROBE ACTIVE: Y  
 PAP.EDGE DETEC.: N  
 SPECIAL FORMS: N

IBM-PP  
 EMULATION: P.P.II  
 PASSBOOK: Y  
 BINDING: VERTICAL  
 SIDE: L  
 CHAR SET: PC  
 PC CHAR SET: 437 (INT)  
 PC TABLE: TABLE 2  
 CHAR DEFINITION: DRAFT  
 CPI: 10  
 LF=LF+CR: N  
 CR=CR+LF: N  
 ZERO SLASH: N  
 LINE LENGTH: 80  
 FORM LENGTH: 12  
 BOF IBM-PP LIKE: Y  
 TOF IBM-PP LIKE: Y

OLIVETTI  
 EMULATION: PR2E  
 PASSBOOK: Y  
 BINDING: VERTICAL  
 SIDE: L  
 CHAR SET: OLIVETTI  
 OLI. CHAR SET: ST15INT  
 CHAR DEFINITION: DRAFT  
 CPI: 10  
 COMPRESSED: 16.6  
 VERTICAL RESOL.: 1/240inch  
 LF=LF+CR: N  
 LINE LENGTH: 90  
 REPLY SYNCRON.: N  
 STATUS REQUEST: NO WAIT

Fig. 3-3 Print Test Example - PR2 E Basic Version



Needles test:

1	2	3	4	5	6	7	8	9	0	1	1	1	1	1	1	1	1	1	1	2	2	2	2	2	0	1
																									D	V

CONFIG.

DRAFT SPEED: NORMAL  
 LQ TYPE: NLQ1  
 PAPER WIDTH: FIRST LINE  
 BUZZER: Y  
 INTERFACE: DUAL  
 RS1 EMULATION: OLIVETTI  
 BAUD RATE: 9600  
 BIT/CHAR: 8  
 PARITY: NONE  
 STOP BIT: 1  
 DSR: Y  
 DCD: Y  
 CX EMULATION: IBM  
 STROBE ACTIVE: N  
 PAP.EDGE DETEC.: N  
 SPECIAL FORMS: N

IBM-PP  
 EMULATION: P.P.II  
 PASSBOOK: N  
 SIDE: L  
 CHAR SET: PC  
 PC CHAR SET: 437 (INT)  
 PC TABLE: TABLE 2  
 CHAR DEFINITION: DRAFT  
 CPI: 10  
 LF+CR: N  
 CR+LF: N  
 ZERO SLASH: N  
 LINE LENGHT: 80  
 FORM LENGTH: 12  
 BOF IBM-PP LIKE: Y  
 TOF IBM-PP LIKE: Y

OLIVETTI  
 EMULATION: PR2E  
 PASSBOOK: N  
 SIDE: L  
 CHAR SET: IBM/PC  
 IBM CHAR SET: ISO  
 ISO SET: ISO 8859/5  
 CHAR DEFINITION: DRAFT  
 CPI: 10  
 COMPRESSED: 16.6  
 VERTICAL RESOL.: 1/216inch  
 LF+CR: N  
 LINE LENGHT: 90  
 REPLY SYNCRON.: N  
 STATUS REQUEST: NO WAIT

OPTION HOR.MSRW  
 STANDARD: IBM 3604  
 END-SENTINEL: C  
 DISPLACEMENT: STANDARD  
 DUPLICATE: N  
 DOUBLE FIELD: Y  
 RETRY: 3  
 STRIPE HANDLING: NORMAL

Fig. 3-4 Print Test Example - PR2 E + Horizontal Magnetic Device

### 3.4 CONNECTION TO THE SYSTEM

In its basic configuration, the printer is equipped with an on-board standard RS232 C interface and a slot for the installation in field of an optional interface card that connects to the specific connector on the main board. One of the following two optional interface cards can be installed in the slot on the rear of the printer:

- RS 232C serial interface + USB interface card
- Centronics parallel interface card

In its dual-port configuration, and therefore configured with the standard serial interface and serial interface + USB interface card or with the standard serial interface and parallel interface card, the printer can operate in run-time mode on the available interfaces so as to satisfy specific application requirements.

#### 3.4.1 RS 232C SERIAL INTERFACE (STANDARD)

Attach the serial cable to the interface located on the rear of the printer.

Via Set-up (Section 4.3.2) program the following interface parameters:  
BAUD RATE; BIT/CHAR; PARITY; STOP BIT; DSR and DCD.

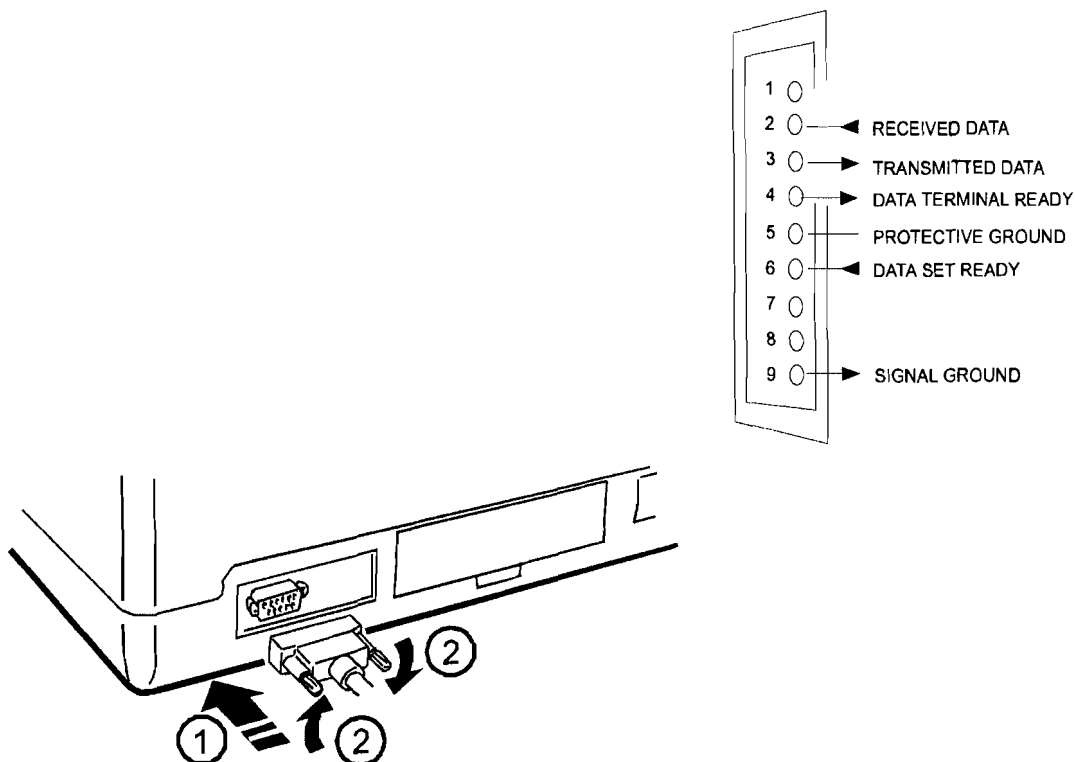


Fig. 3-5 Standard RS232 C Serial Interface

### 3.4.2 OPTIONAL SERIAL INTERFACE + USB INTERFACE CARD

The optional serial interface + Universal Serial Bus (USB) interface card hosts both interfaces and is installed in the specific slot alongside the standard first serial interface on the rear of the printer. This interface card is shown in the following figure.

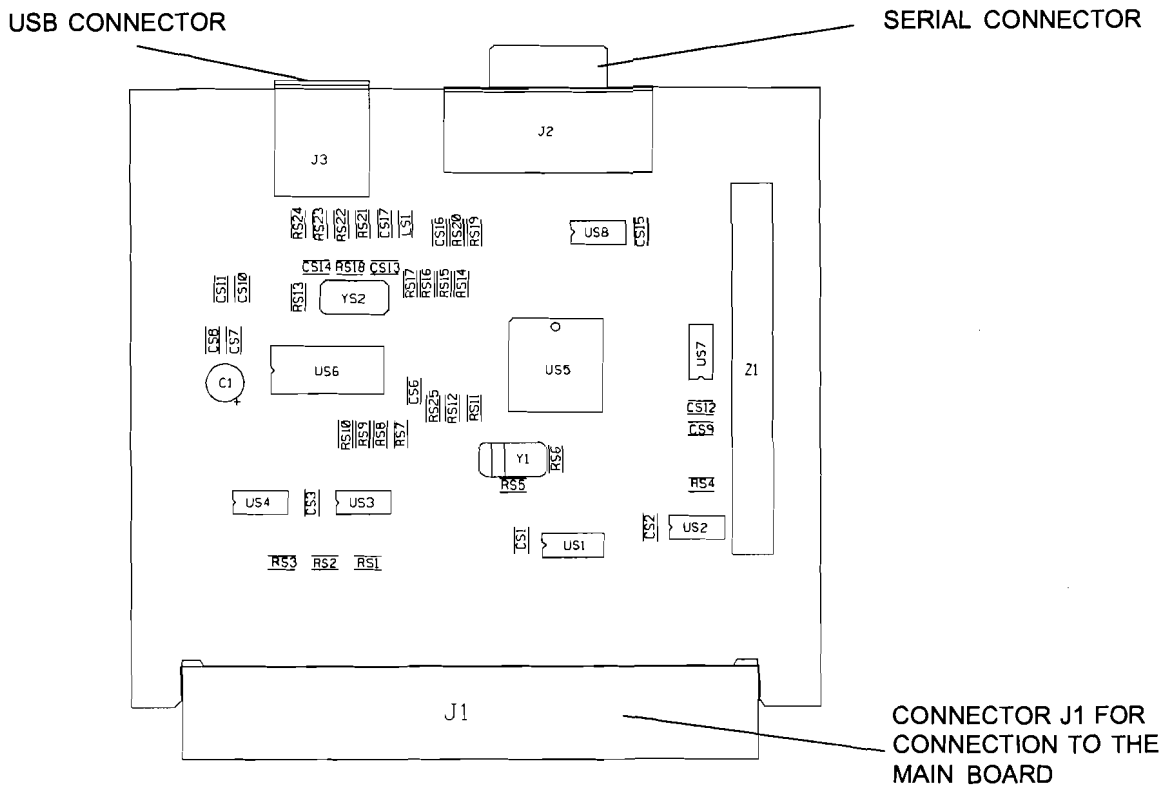


Fig. 3-6 Serial Interface + USB Interface Card

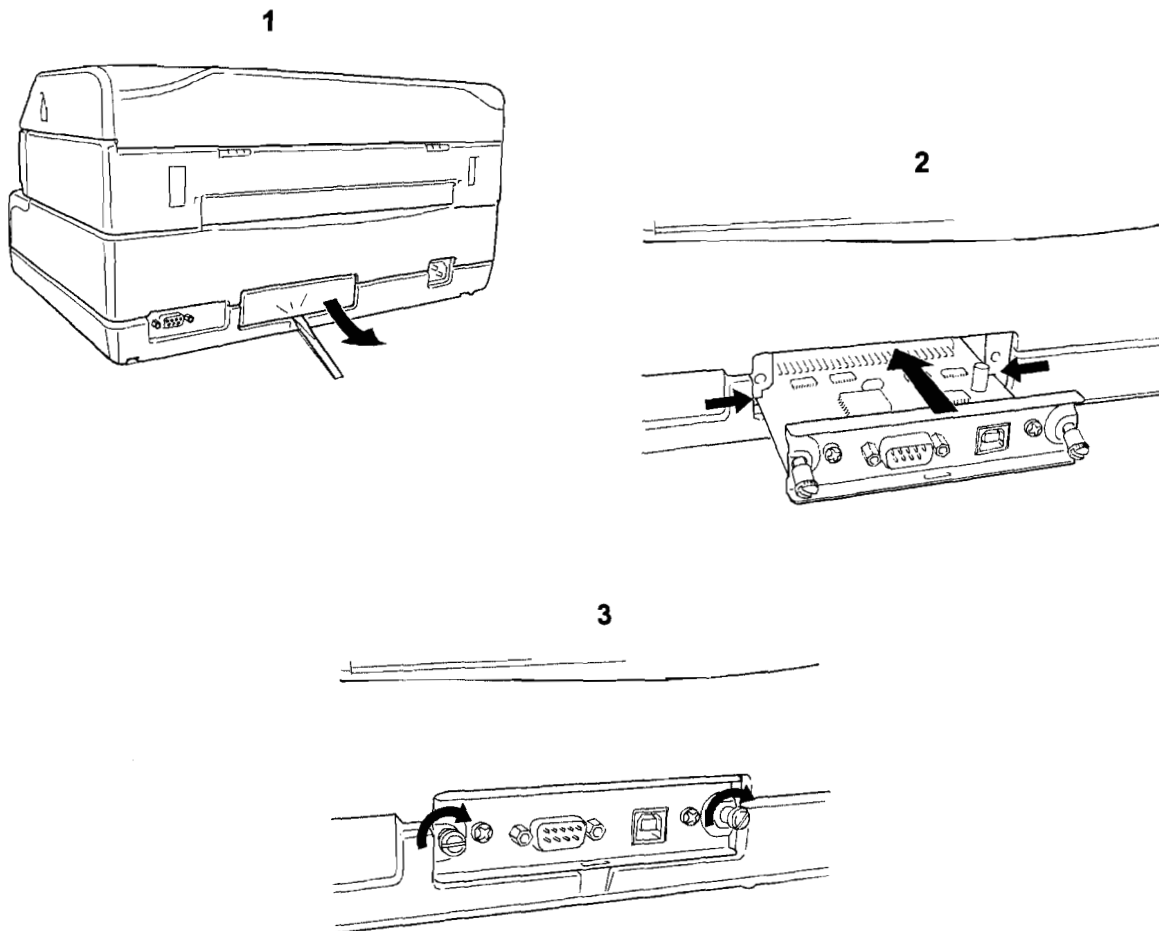
This serial interface has the same characteristics as the main board serial interface, while the USB interface complies with the Universal Serial Bus Specification - Revision 1.1 reference standard and has a transfer rate of  $\geq 200$  kbps.

<b>J2</b>		<b>J3</b>	
(RS232 Serial Interface)		(USB Interface)	
1	DCD1	1	VBUS
2	REXD1	2	DMENO
3	TXD1	3	DPIU
4	DTR1	4	GND
5	GND		
6	DSR1		
7	CTS1		
8	TAS01		
9	TERRSE		

Fig. 3-7 USB Interface Pin-Out

Proceed as follows to install this optional card:

- Power off the printer.
- Using a screwdriver, break off the slot cover of the optional serial interface on the rear of the printer.
- Insert the interface card in the slot and slide it along the guideways until it plugs into the related connector on the main board. Push firmly to ensure proper connection.
- Tighten the card's two side screws to secure it in place.



*Fig. 3-8 Installing the Serial Interface + USB Interface Card*

Once the optional serial interface + USB interface card is installed, only the two serial interfaces are operational simultaneously. In this configuration, with an empty buffer and in an out of paper condition, the printer polls the two ports to see which one will be assigned. When a signal is received by any one of the two interfaces, the printer switches to the receiving interface and maintains this condition until the end of the print job. The assignment of the interfaces is mutually exclusive.

In addition to the active emulation, the two interfaces have the same parameter settings. The active emulation can be changed by an on-line command.

### 3.4.3 OPTIONAL IEEE 1284 PARALLEL INTERFACE CARD

The optional parallel interface card hosts a 36-pin Centronics parallel interface. It is installed in the specific slot alongside the first serial interface on the rear of the printer. It is suggested to use an interface cable up to 1.5 meters long. The ECP data exchange protocol is used.

This card is shown in the following figure.

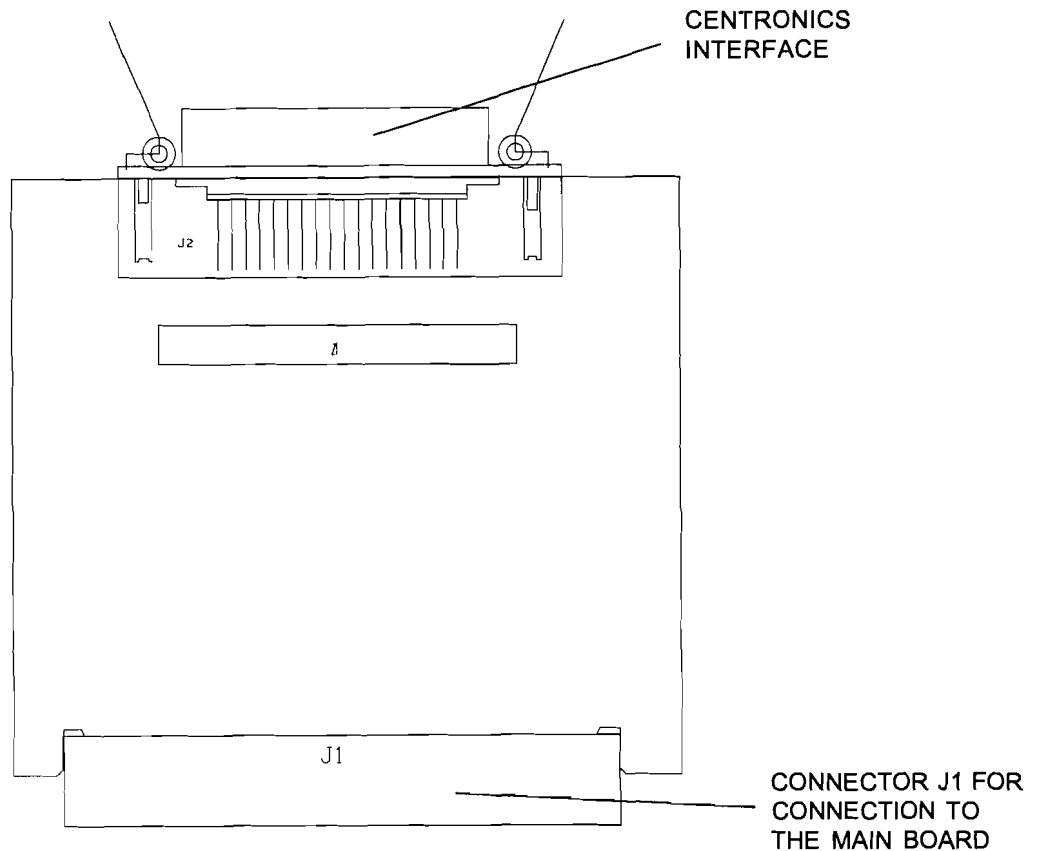


Fig. 3-9 Parallel Interface Card

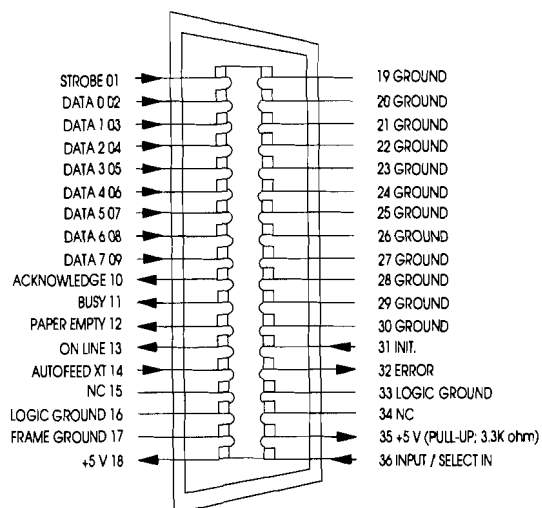
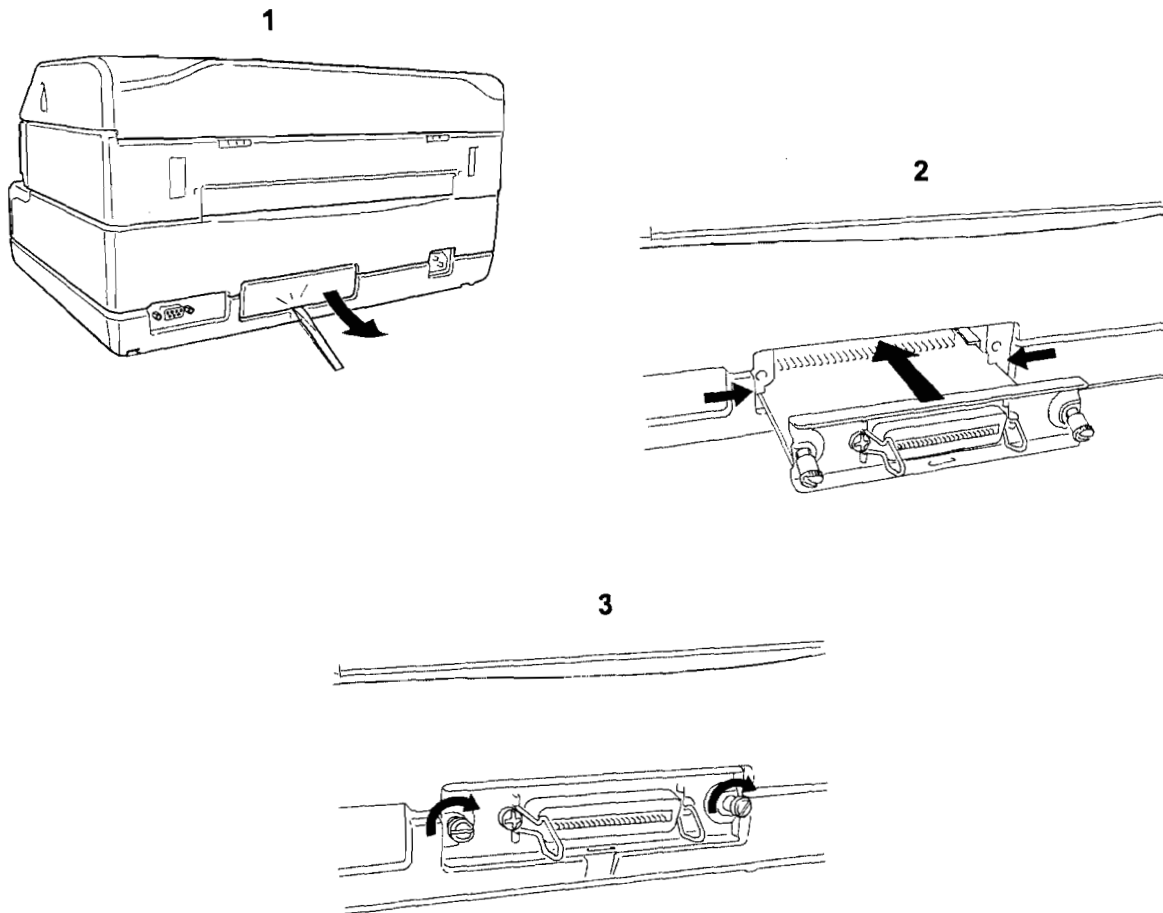


Fig. 3-10 Parallel Interface Pin-Out

Proceed as follows to install this optional card:

- Power off the printer.
- Using a screwdriver, break off the slot cover of the optional serial interface on the rear of the printer.
- Insert the interface card in the slot and slide it along the guideways until it plugs into the related connector on the main board. Push firmly to ensure proper connection.
- Tighten the card's two side screws to secure it in place.



*Fig. 3-11 Installing the Parallel Interface Card*

In a printer dual-port configuration consisting of the standard serial interface + parallel interface, in an empty buffer and out of paper condition the printer polls the two ports to see which one will be assigned. When a signal is received by any one of the two interfaces, the printer switches to the receiving interface and maintains this condition until the end of the print job. Dual-port functionality is configured during printer set-up; in particular, active emulation can be set on each of the two interfaces and can be changed in run-time mode by means of a specific command.

### 3.5 FINAL TESTING

After connecting the printer to the system, test its interface parameters. The PR2 E has a resident run-in test which is useful to check the outcome of the ordinary maintenance intervention. Proceed as follows to perform this test:

- Power on the PR2 E by pressing the STATION 2/EJECT button with the printer cover open. Upon completion of the reset routine, close the printer cover and insert an A4 sheet of paper (for the printing of the self-test). When the sheet of paper is expelled, press the LOCAL/BREAK and STATION 2/EJECT buttons simultaneously (RUN-IN test). The test lasts about 45' and vertical bars are printed. In this test mode, the efficiency of the machine's mechanics and electronics is tested just like at the factory. Power off the printer to exit from the run-in test mode.

### 3.6 INFORMATION FOR THE OPERATOR

After installation, the field engineer has the responsibility of informing the operator on how to use the printer, how to replace the cartridge and how to clear paper jams. It is suggested that a practical demonstration be given for the following operations:

- Using the console, interpreting the error messages and unlocking the machine whenever necessary.
- Inserting a savings book and sheets of paper into the front insertion slot, stressing the importance of avoiding the use of crumpled or torn paper or savings books with jutting spines. Show how to insert the sheet of paper (automatic alignment) and the savings book (manual alignment).
- Replacing the ribbon cartridge.
- Removing a jammed document from the printer by using the lever for lifting the upper mechanical assembly.
- Inserting a check or tab in the optional check reader, making sure to avoid using documents that are torn, wrinkled, folded, stapled or held together with paper clips.

Stress the importance of good internal ventilation and therefore the need to keep the printer vents unobstructed (from forms or other types of paper).

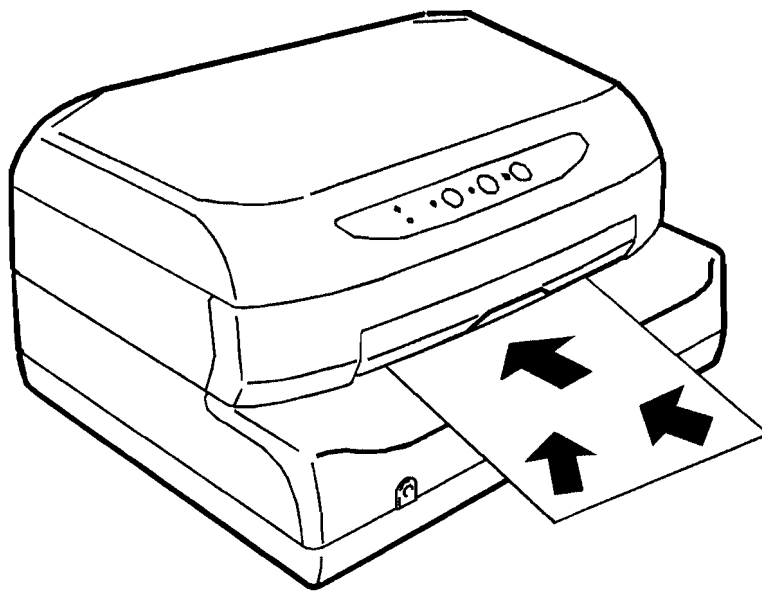
Make it clear to the operator that observing these simple precautions ensures good printer operation in time. If failures should arise, however, the operator should promptly call the field engineering service.

## 3.7 OPERATING PROCEDURES

### 3.7.1 INSERTING A DOCUMENT WITH AUTOMATIC ALIGNMENT

The front shelf on the case helps to insert the document in the printer.

- With the printer powered on, place the document at the center of the front slot and then insert it into the feed slot.
- Release the document as soon as the automatic alignment system is activated.



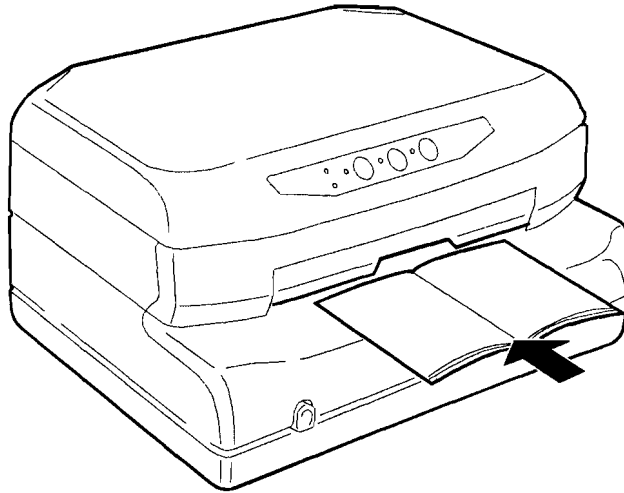
*Fig. 3-12 Automatic Document Insertion*



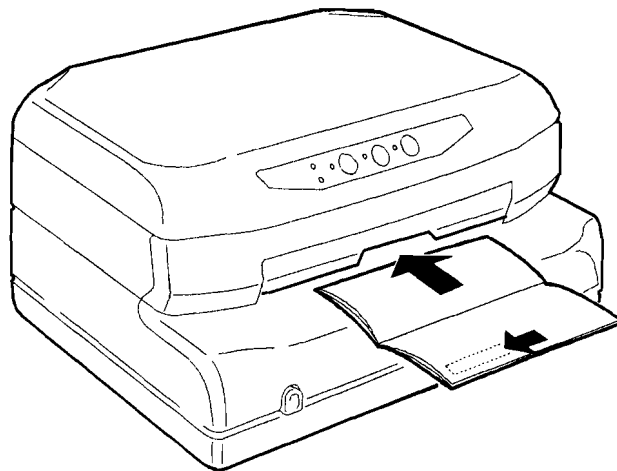
### 3.7.2 INSERTING A SAVINGS BOOK

Before inserting a savings book, open it and press it along its spine so that it remains completely open horizontally. Make sure that pages of the book are not folded or ripped so as to prevent a poor print quality and errors during book insertion.

Place the open savings book on the front shelf with the magnetic stripe on the bottom.



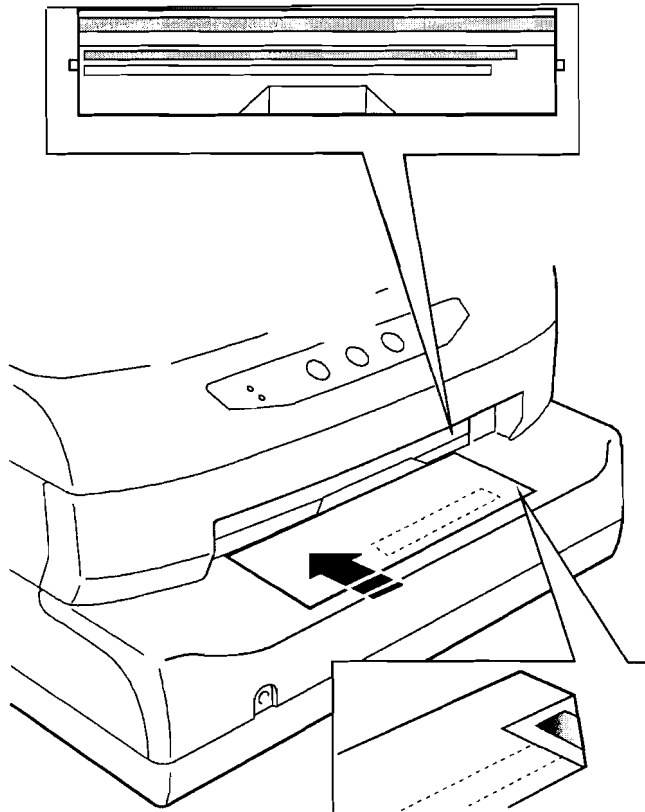
*Fig. 3-13 Manual Insertion of a Savings Book*



*Fig. 3-14 Manual Insertion of a Savings Book with Magnetic Stripe*

### 3.7.3 INSERTING A CHECK FOR HORIZONTAL MAGNETIC DEVICE/MICR READ OPERATIONS

On the front of the machine cover there is a reference stripe to be used when inserting checks.



*Fig. 3-15 References for the Insertion of Checks*

### 3.7.4 EXPULSION OF PROCESSED DOCUMENTS

The processed documents can be expelled from the printer, according to the application program, in the following ways:

- Returning back to where the documents were manually inserted (paper feed slot)
- From the printer's rear slot, starting from the front feed slot

If the documents that are expelled from the front feed slot:

- are less than 100 mm long, they will be released from the feed rollers
- are 100 mm long or longer, they will remain gripped by the last set of rollers to avoid that the document tails off the front shelf.

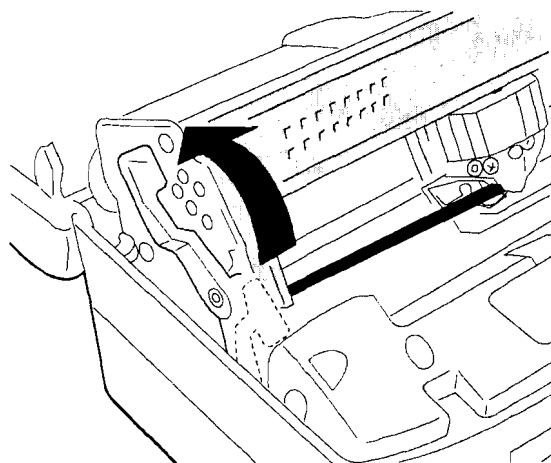
### 3.7.5 REPLACING THE RIBBON CARTRIDGE

The ribbon cartridge must be changed when printing is incomplete or faded, or when there are frequent optical read errors on the printed documents. This procedure is to be performed with the machine powered off; if necessary, however, it can even be performed with the machine powered off.

#### 3.7.5.1 REPLACING THE RIBBON CARTRIDGE WITH THE MACHINE POWERED OFF

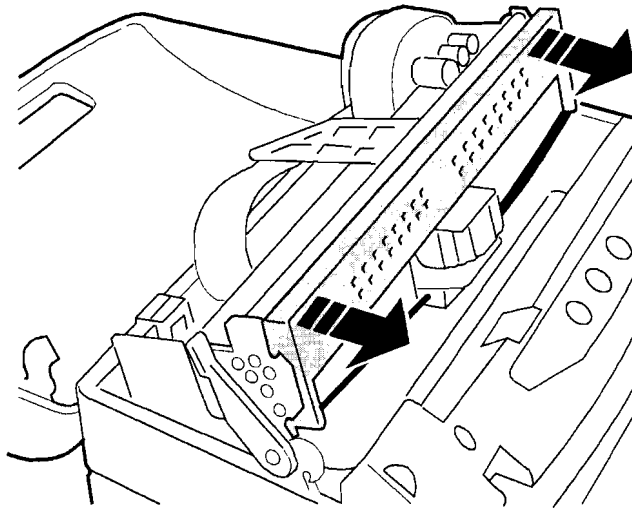
Proceed as follows to change the ribbon cartridge:

- Power off the machine.
- Open the printer top cover.
- Lift the upper mechanical assembly by pushing the appropriate lever.



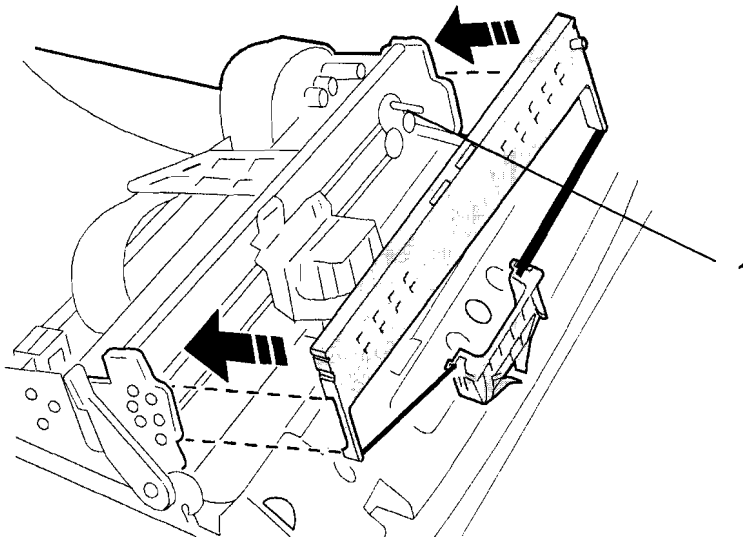
*Fig. 3-16 Lifting the Upper Mechanical Assembly*

- Push the ribbon guide downwards until it releases from the print carriage.
- Remove the old cartridge by pulling it outwards.



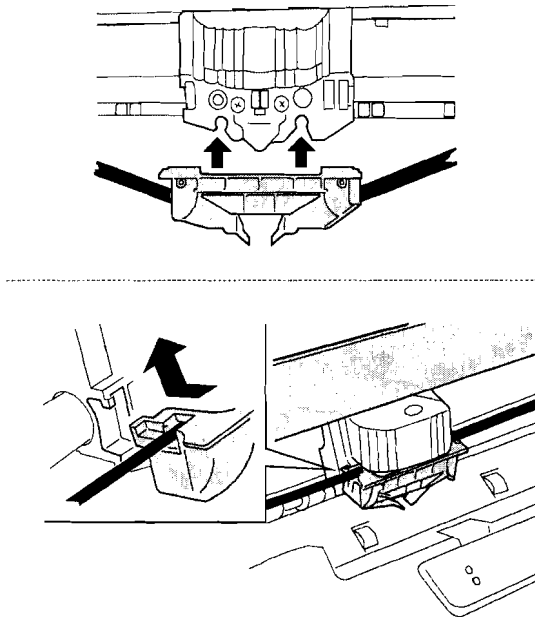
*Fig 3-17 Removing the Ribbon Cartridge*

- Insert the cartridge into the feed gears, hooking it on the two sides and making sure to insert pin (1) into the related hole of the ribbon feed knob.



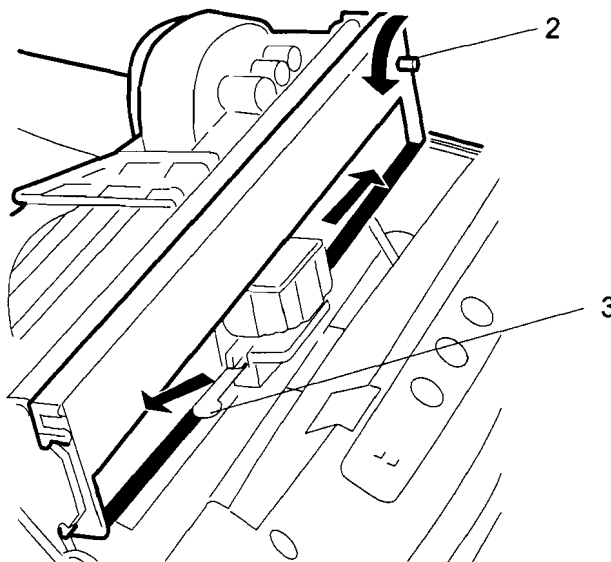
*Fig. 3-18 Inserting the Ribbon Cartridge*

- Insert the ribbon guide frontwards and then lift it until it hooks on to the two elastic pins on the carriage's open slots behind behind the printhead platen (a "clack" sound is heard).



*Fig. 3-19 Hooking the Ribbon Guide*

- Turn the carriage knob counterclockwise (2) until the ribbon is taut and then remove tab (3).



*Fig. 3-20 Removing the Tab*

- Using the specific lever, completely lower the upper part of the mechanical assembly containing the printhead and ribbon cartridge.
- Close the printer cover.
- Power on the machine.

### **3.7.5.2 REPLACING THE RIBBON CARTRIDGE WITH THE MACHINE POWERED OFF**

The ribbon cartridge can be changed with the machine powered on and by following the procedure listed below:

- Open the printer cover; printing stops automatically.
- Lift the upper mechanical assembly by using the appropriate lever.
- Remove the used cartridge and replace it with a new one as previously described.
- Lower the upper mechanical assembly by using the appropriate lever.
- Close the printer cover.

**Note: DO NOT move the printhead manually.**

### **3.7.6 PAPER JAMS**

The paper could jam along its path inside the machine.

Jamming could be caused by one of the following:

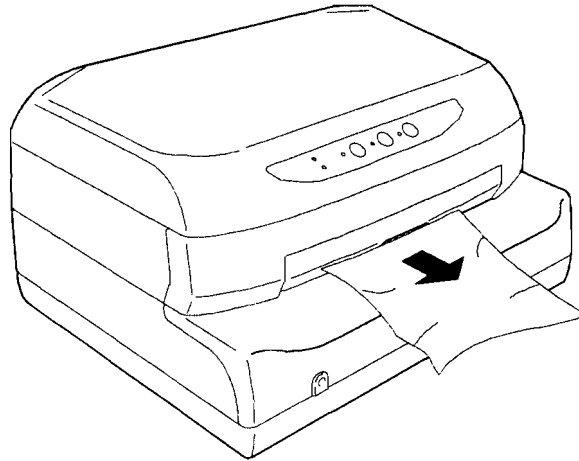
- Obstructed paper path (for example, residual pieces of paper)
- Paper skew
- Paper weight or size non-compliant with the specifications
- Crumpled, folded or badly preserved paper
- Stapled paper or with paper clips (this can seriously damage the machine)
- Multicopy forms where the sheets are poorly glued together.

The areas where jams are more likely to occur are:

- front document feed slot
- inside the printer
- rear document output slot

### **3.7.6.1 PAPER JAMS AT THE FRONT DOCUMENT FEED SLOT**

To remove a jammed document from the front feed slot, carefully pull the document from the printer to avoid ripping it.

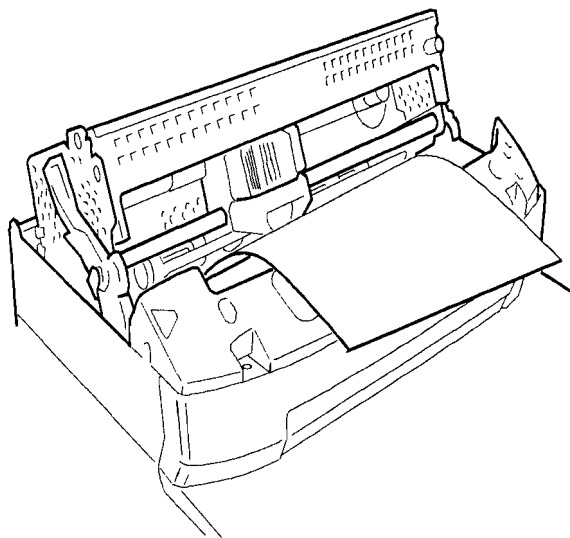


*Fig. 3-21 Removing the Document from the Front Feed Slot*

### **3.7.6.2 PAPER JAMS INSIDE THE PRINTER**

Proceed as follows to remove a document from inside the printer:

- Open the cover without powering off the machine.
- Lift the upper mechanical assy by using the upper mechanical assy lifting lever.
- Remove the jammed document by carefully pulling it from the printer.



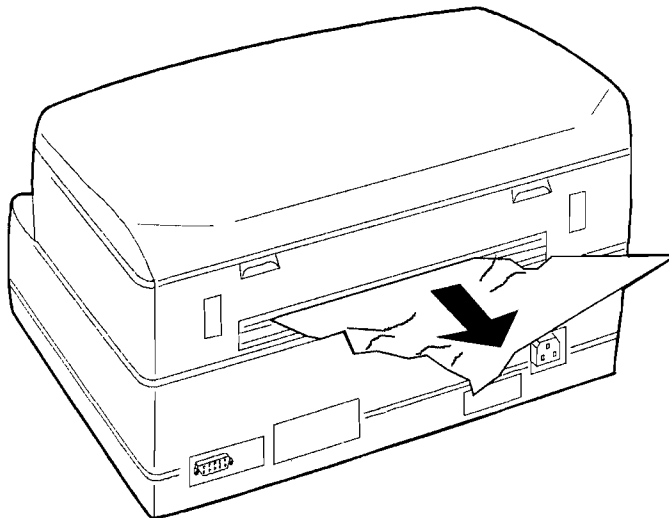
*Fig. 3-22 Removing a Document from Inside the Printer*

If pieces of paper are jammed in unaccessible areas inside the machine, proceed as follows to remove them:

- 1) Open the cover and power on the printer while pressing the STATION 1/EJECT button.
- 2) Wait for an audible signal to sound.
- 3) Press STATION 1/EJECT and/or STATION 2/EJECT to move the paper forward/backward so that the jam can be cleared.
- 4) Power off the machine and close the cover before powering it back on again.

### **3.7.6.3 PAPER JAMS AT THE REAR OUTPUT SLOT**

To remove a document from the rear output slot, without opening the cover carefully pull the document outward trying not to tear it.



*Fig. 3-23 Removing a Document from the Rear Output Slot*



## 4. AUTODIAGNOSTICS, SETUP AND ADJUSTMENTS

### 4.1 POWER-ON DIAGNOSTICS

At power on, besides a general reset the printer runs an autodiagnostic routine that checks the efficiency of all machine components.

Upon the successful completion of the autodiagnostic routine the printer switches to the READY state (ON and READY LEDs lit).

The table below indicates the meaning of the LEDs according to the type of failure detected during the autodiagnostic phase.

FAILURE \ LED	ON	READY	ST1	LOCAL	ST2
Power supply assy failure	OFF	OFF	OFF	OFF	OFF
On-board failure: - Eprom - ROM - Microprocessor	ON	OFF	OFF	OFF	OFF
Failure with: - Fuses - Drivers - Motors	ON	ON	ON	ON	ON
Activation board failure	The motors do not perform any kind of movement				

## 4.2 PRINT TEST

The print test provides a printout of the machine's set-up parameters.

The instructions to run this test are given in section 3.3, Off-line Testing.

## 4.3 PRINTER SET-UP

The Set-up environment should only be accessed by the service engineer and programmer since some of the selectable parameters are used to customize the machine or option installed and must therefore not be changed. An incorrect intervention by the operator could cause printer malfunction.

### 4.3.1 ACTIVATING THE SET-UP

To enter the set-up environment, power off the machine and then power it back on again while pressing the ST1 (Station 1) and ST2 (Station 2) buttons simultaneously.

Upon completion of the printer reset phase, load an A4 sheet of paper: the machine will print a line with a description of the functions of all the keys in this environment.

The flow charts on the following pages indicate the different ways in which the various set-up environments can be accessed.

### 4.3.2 SUPPORT SOFTWARE

The software tools include all tools and languages that the product needs for the environments in which it will be used.

- Promotional demo

The program features an appropriate product presentation format and exploits all the operating modes and options available.

It highlights the features and performance offered by the printer in every configuration and optimizes the operational cycle so as to reach the maximum performance obtainable.

- Drivers

Based on the Olivetti native protocol, they integrate the entire range of features handled by industry-standard applications.

- Reference command sets STD 12/14 PR2E
- DLL driver provided WIN NT 4.x/2000, WIN 95/98
- Environment DLL WOSA

- Set-up management software

A specific program developed for set-up management on-line. It displays the product's set-up parameters and makes it possible to change them, handshaking included.

- Font and logo management software

A program used to create unusual graphical representations or special fonts.

### 4.3.3 CONFIGURATION PARAMETERS

This section provides the description and possible values of the printer's different set-up parameters.

The default value is indicated in bold.

#### 4.3.3.1 CONFIGURATION MODE MENU PARAMETERS

DRAFT SPEED: <u>NORMAL</u> - HIGH	Determines the Draft mode that can be activated via SW and by default.
LQ TYPE: <u>NLQ1</u> - NLQ2 - LQ2	Determines the LQ type that can be activated via SW and by default
PAPER WIDTH: <u>FIRST LINE</u> – PROGRAMMABLE	Determines document position/width measurement position.
BUZZER: N - <u>Y</u>	Activates/deactivates acoustic signaling
INTERFACE: <u>RS 232 (1)</u> – OPTIONAL – DUAL	The optional interfaces are: - PARALLEL (DUAL-compatible) - RS 232 (2) (DUAL-compatible) - USB

---

#### (when) RS232C (1)

EMULATION: <u>OLIVETTI</u> – IBM	Interface default emulation
BAUD RATE: <u>9600</u> - 4800 - 2400 - 1200	Data transmission/reception rate
BIT/CHAR: 7 - 8	7- or 8-bit data format.
PARITY: <u>NONE</u> - ODD - EVEN	Type of parity checking.
STOP BIT: <u>1</u> - 2	Number of stop bits
DSR: N - <u>Y</u>	Data Set Ready handled or not.
DCD N - <u>Y</u>	Data Carrier Detector handled or not.

PAPER EDGE DETECTION: N - Y

When enabled (Y), inhibits the printing of lines that are wider than the sheet inserted. Causes a paper jam (ESC r 1) in the Olivetti environment.

For electronic HW reasons, the width of the document is automatically measured only during the document insertion phase. Therefore if the sheet of paper loaded has a variable width, the different size will not be detected during the printing phase.

SPECIAL FORMS: N - Y

When enabled (Y), every paper movement is performed with the printhead positioned outside the margins of the sheet of paper. This makes it possible to use the lightest forms indicated in the paper specifications thus avoiding the forms to crumple.

SAVE PARAMETERS: Y - N

Stores or not the settings made.

---

## **IBM Menu**

EMULATION: P.P. II - X 24

Selects the IBM emulation wanted

---

(when) X24

AGM: N - Y

Enables/disables the AGM function.

---

PASSBOOK: N - Y

Indicates whether the printer is enabled or not to handle savings books.

---

(when) Passbook Y

BINDING: VERTICAL - HORIZONTAL

Used when the "PASSBOOK: Y" setting is made. Selects the type of savings book binding (horizontal or vertical). If horizontal binding is selected, during a savings book print job the printhead will move outside the margins of the savings book so as to improve the feed of the savings book itself.

SIDE : L - R

Selecting "R (Right)" ensures SW compatibility with the PR50 with right-hand alignment. Selecting "L (Left)" ensures SW compatibility with the PR50 with left-hand alignment.

---

CHAR SET: PC - ISO

Character generator selection.

---

(when) PC CHAR SET:

DK/N

DK

210 (GR)

220 (E)

437 (INT)

850 (LATIN 1)

851 (GREEK)

852 (LATIN 2)

855 (CYRILLIC)

857 (LATIN 5)

858 (LATIN EURO)

860 (P)

862 (IL)

863 (CANADIAN FRENCH)

864 (ARABIC)

865 (NORDIC)

866 (CYRILLIC)

1250 (PC WIN Latin2)

1252 (PC WIN Latin1)

**(when) ISO SET:**

OLI-UNIX  
ISO 8859/1  
ISO 8859/2  
ISO 8859/5  
ISO 8859/6  
ISO 8859/7  
ISO 8859/8  
ISO 8859/9  
ISO 8859/15

---

PC TABLE: TABLE 1 - <u>TABLE 2</u>	Selects the character generator table.
CHAR DEFINITION: LQ - <u>DRAFT</u>	Selects the character definition.
CPI: <u>10</u> - 12 - 17.1	Selects the print pitch expressed in number of characters per inch.
LF + CR: <u>N</u> - Y	Selects or not the execution of an automatic carriage return each time a line feed command is received.
CR + LF: <u>N</u> - Y	Selects or not the execution of an automatic line feed each time a carriage return command is received.
ZERO SLASH: <u>N</u> - Y	Enables/disables slashed zero printing.
LINE LENGTH: <u>80</u> - 90	Selects maximum print line length expressed in number of character at 10 cpi.
FORM LENGTH: 11 - <u>12</u>	Selects the maximum form length expressed in inches.
BOTTOM MARGIN IBM-PP LIKE: N - <u>Y</u>	Selects the form's bottom margin (BOF). N - The Bottom of Form value is 4.23 mm. Y - The Bottom of Form value is 13.7 mm.

TOP MARGIN IBM-PP LIKE: N - Y

Selects the form's top margin (TOF).

N - The Top Of Form value will be included between 4.23 mm (defined by the adjustment) for documents and 7.4 mm per savings books.

Y - The Top Of Form value will be 4.23 mm for documents and 7.4 for passbooks.

PNS SELECTION: N - Y

Selecting (Y) grants access to the PNS selection menu in the IBM environment.

---

(when) PNS SELECTION: Y

PNS # 4192 : N - Y

If enabled, upon reception of a Form Feed command the document is expelled regardless of the form length selected.

PNS # 4501 : N - Y

Selects a 1/5" spacing value.

SAVE PARAMETERS: Y - N

Stores or not the settings made.

---

## Olivetti Menu

EMULATION: PR2E - PR40

Selects the OLIVETTI emulation

---

**(when) PR40+**

LINE BUFFER PR40 LIKE: N - Y

Sets the reception buffer length like the PR40 (1K byte) or to 8 K byte.

TOP MARGIN PR40 LIKE: N - Y

TOF management with fixed (PR40) or adjustable mechanical header.

---

**(when) PR2E**

PASSBOOK: N - Y

Enables the printer to handle savings books.

---

**(when) Passbook Y**

BINDING: VERTICAL - HORIZONTAL

Used when the "PASSBOOK: Y" setting is made. Selects the type of savings book binding (horizontal or vertical). If horizontal binding is selected, during the printing on a savings book the printhead is positioned outside the margin of the savings book so as to improve the feed of the book itself.

---

SIDE : L - R

Selecting "R (Right)" ensures SW compatibility with the PR50 with right-hand alignment. Selecting "L (Left)" ensures SW compatibility with the PR50 with left-hand alignment.

---

CHAR GENERATOR: IBM/PC - OLIVETTI Selects the character generator.

---

**(when) IBM CHAR SET: PC - ISO**

IBM emulation PC or ISO character sets regardless of the selection made.



**(when) PC CHAR SET:**

DK/N  
DK  
210 (GR)  
220 (E)  
437 (INT)  
850 (LATIN 1)  
851 (GREEK)  
852 (LATIN 2)  
855 (CYRILLIC)  
857 (LATIN 5)  
858 (LATIN EURO)  
860 (P)  
862 (IL)  
863 (CANADIAN FRENCH)  
864 (ARABIC)  
865 (NORDIC)  
866 (CYRILLIC)  
1250 (PC WIN Latin2)  
1252 (PC WIN Latin1)

---

**(when) ISO SET:**

OLI-UNIX  
ISO 8859/1  
ISO 8859/2  
ISO 8859/5  
ISO 8859/6  
ISO 8859/7  
ISO 8859/8  
ISO 8859/9  
ISO 8859/15

**(when) OLIVETTI CHAR SET:**

INT  
USA  
D  
P  
E  
E2  
DK/N  
F  
I  
S/SF  
CH  
UK  
YU  
IL  
GR  
CND  
STD 31  
SDC  
TR  
ARABIC  
USSR  
CIBC

---

CHAR DEFINITION: <u>DRAFT</u> - LQ - OCRA - OCRB	Selects the character definition.
CPI: 5 - <u>10</u> - 12 - 15 - 16.6 - 17.1	Selects the print pitch.
COMPRESSED: <u>16.6</u> - 17,1	Defines the spacing selected with ESC >
VERTICAL RESOLUTION: 1/216" - <u>1/240"</u>	Selects the vertical resolution.
LF + CR: <u>N</u> - Y	Selects whether to execute or not an automatic carriage return each time a line feed command is received.

LINE LENGTH: 90 - 94

Selects the maximum print line length expressed in number of characters at 10 cpi.

PRINTER REPLY SYNCHRONIZED: N - Y

DSR management during a transmission

STATUS REQUEST: NO WAIT - WAIT

Determines the timing of the status reply upon reception of an ESC j command. By selecting NO WAIT, the reply will be provided as soon as possible and simultaneously with the execution of a print job or paper movements. By selecting WAIT, the status reply will be provided at the end of the print job.

---

**(if the Horizontal Magnetic device/MICR is present)**

OPTION HORIZONTAL MSR<sub>W</sub>

This message warns that the option is installed. There is no selection to be made, and the next option available is printed right after it. If the Horizontal magnetic device/MICR option is present, the caption "+MICR" will appear next to "MSR<sub>W</sub>".

---

STANDARD: DIN/ISO - ANSI - IBM 3604

Sets the magnetic standard.

---

**(when) IBM 3604**

END-SENTINEL: C - F

Sets the end-sentinel code.

DISPLACEMENT: STANDARD +10 +20 Defines the position of the magnetic stripe.

DUPLICATE: N - Y

Selects field duplication or not.

DOUBLE FIELD CHECK: N - Y

Selects double field check or not

RETRY: 3 - 1

Defines the read attempts.

STRIPE HANDLING: NORMAL - FAST

Defines normal or fast magnetic stripe reading. When Normal is selected, at each magnetic stripe read or write operation a savings book length measurement is performed so as to determine the exact position of the stripe. When Fast is selected, the length of the savings book is measured randomly with the procedure explained in the specific chapter; savings book measurements are not made during stripe read/writes thus speeding stripe management.

(when) **SIDE : R**

AFF : STD - USA

Selects print line width.

LINE BUFFER PR2845 LIKE: N - Y

Defines the reception buffer length like the 2845 (512 Bytes) or to 8 Kbytes.

NATION:     INT  
              USA  
              D  
              P  
              E  
              E2  
              DK/N  
              F  
              I  
              S/SF  
              CH  
              UK  
              YU  
              IL  
              GR  
              CND  
              STD 31  
              SDC  
              TR  
              IS

---

CHAR DEFINITION: DRAFT - LQ

Selects the character definition.

CPI: 10 - 12

Selects the print pitch.

LF: 1/5" - 1/6"

Selects the line feed.

WARNING:  
END OF PAPER - PHOTO SENSORTOP

Selects the indication for out of paper or for photosensor covered.

TOP OF FORM: 1 - 2

Selects the first or second printable line.

STATUS REQUEST: NO WAIT - WAIT

Determines the timing of the status reply upon reception of an ESC j command. By selecting NO WAIT, the reply will be provided as soon as possible and simultaneously with the execution of a print job or paper movements. By selecting WAIT, the status reply will be provided at the end of the print job.

SAVE PARAMETER ? : Y - N

Stores or not the settings made in this Set-up section.

---

## 4.4 SETTINGS

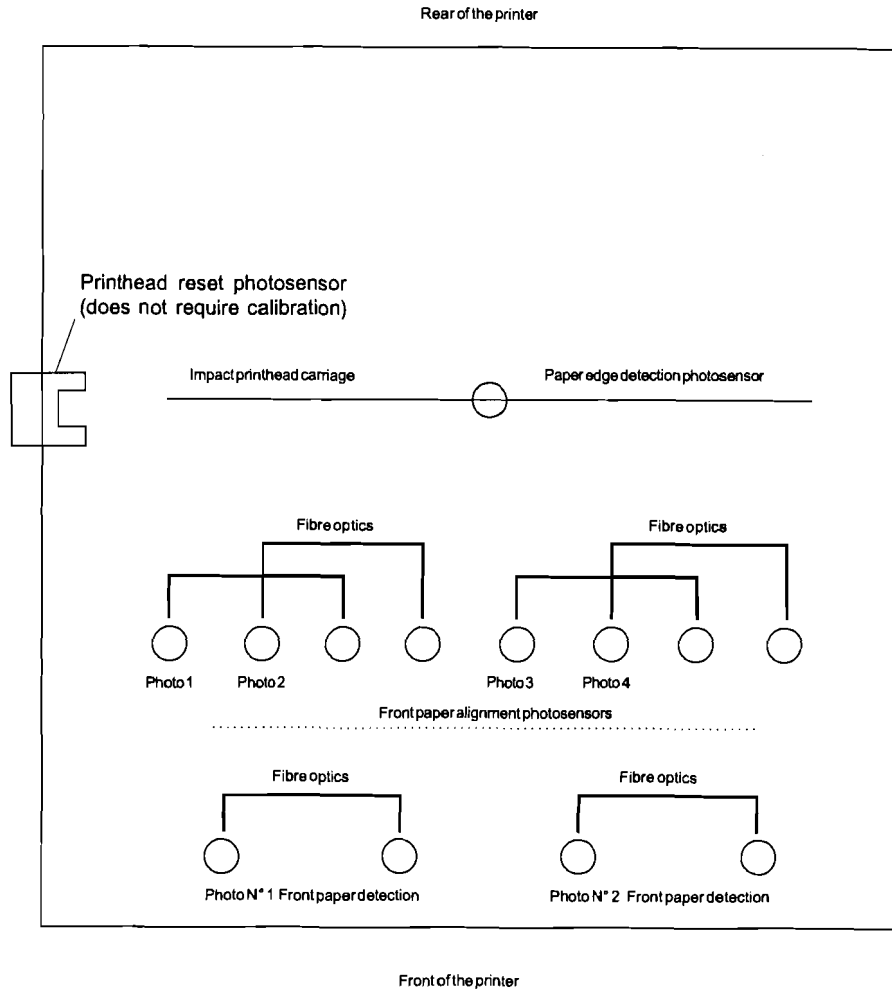
### 4.4.1 PHOTSENSOR CALIBRATION

All machine photosensors are calibrated at the factory. However, a change in the electrical characteristics of the photosensors used or the use of non-standard paper may call for the photosensors to be recalibrated at the customer's site.

All the photosensors present in the machine require calibration; the following are installed:

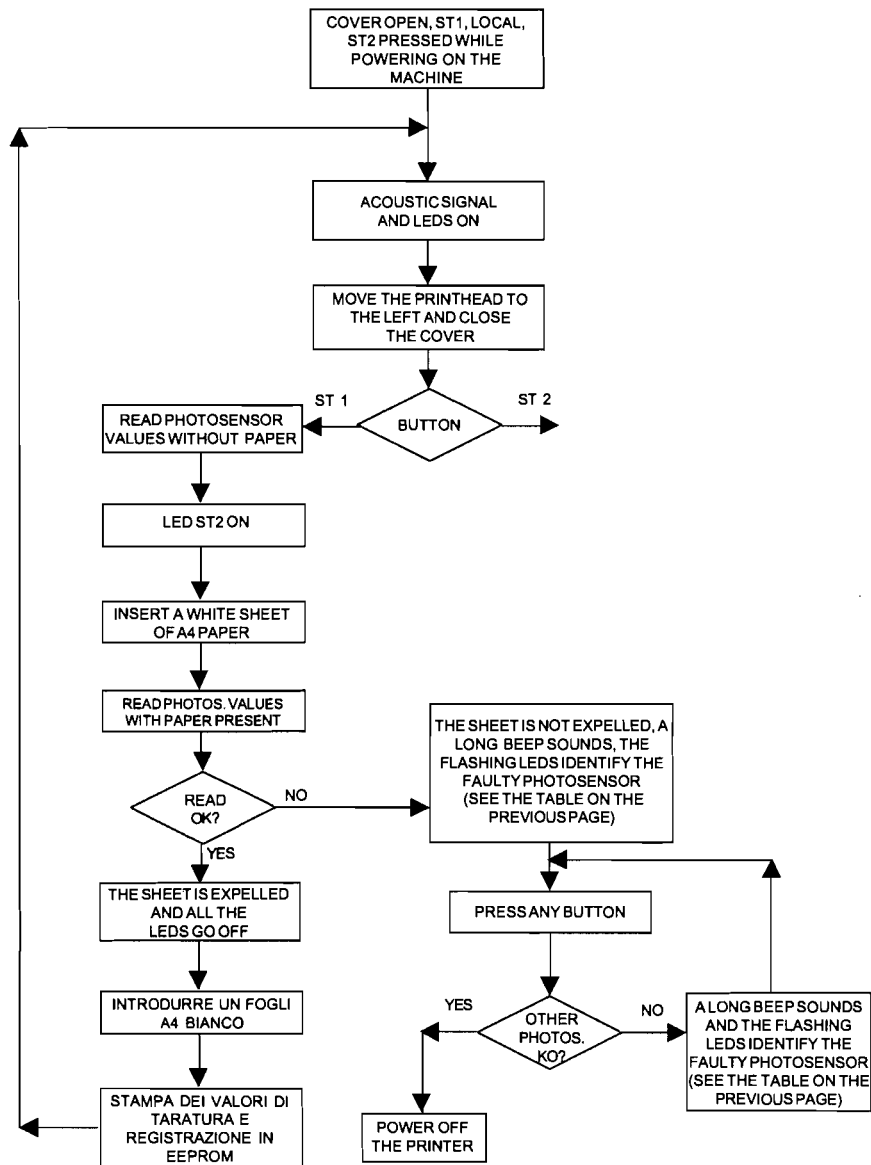
- Paper detection photosensor assembly  
This assembly consists of two LEDs and two photoreceivers that are the first to detect when a document is inserted in the front insertion slot. The ray of light is transmitted by fibre optics.
- Paper font alignment photosensor assembly  
These photosensors are included in the same mechanical assembly as the paper detection photosensors, indicated in this manual as Front photosensor assembly.  
The paper front alignment photosensors check the alignment of the document before it reaches the printhead. The assembly consists of four LEDs and four photoreceivers, all connected via fibre optics.
- Autoborder photosensor  
Fitted on the printhead, it detects the paper so as to measure the position of the first print column. If selected from Set-up, with this sensor it is also possible to control printing interruption in cases when the paper is narrower than the line being printed and sent from the system.

The location of the individual photosensors in the machine is shown in the figure on the following page.



*Fig. 4-1 Locating Machine Photosensors*

Provided below is the photosensor calibration block diagram.

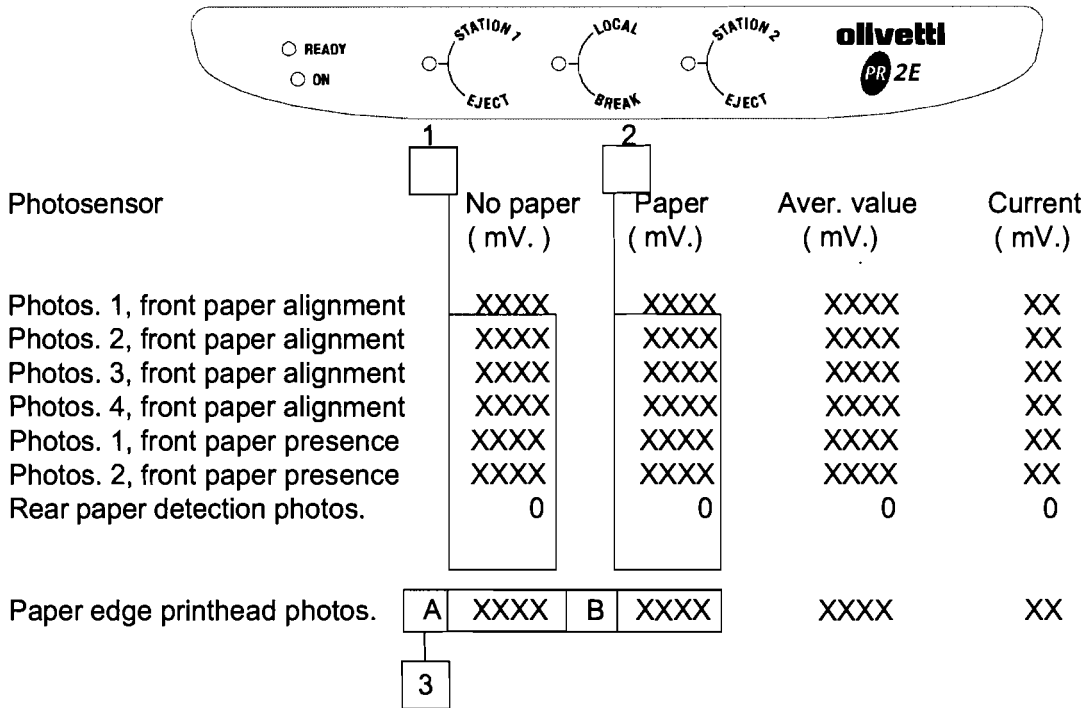




Proceed as follows to calibrate the photosensors:

1. Power on the printer with its cover open and while holding down the three buttons on the console.
2. Wait for the audible signal indicating that the printer has switched to the calibration and adjustment procedures.
3. Manually position the printhead towards the left-hand side and then close the cover.
4. Press the "Station 1" button twice to enter the menu.
5. Upon the completion of this phase, the sensors have stored the electrical current ratings with the printer in an out of paper condition.
6. Insert a sheet of 60 gr/m<sup>2</sup> paper, in the landscape position, into the front insertion slot. During this phase the motor continues to turn forcing the paper against the brush.
7. Press the "Station 2" button. Wait for the sheet feed and expulsion movement to be completed. If no failure is detected, after the expulsion of the sheet of paper the console LEDs will remain off; the reloading of an A4 sheet of paper will allow you to print the values read and selected for each single photosensor.

If calibration does not end successfully, the faulty photosensor is identified through specific LED configurations. Pressing one of the console buttons allows you to identify any other faulty photosensor. In this case, the other calibrations or measurements may not be performed. If, instead, calibration was successful, load an A4 sheet of paper in order to print the calibration values. The following table indicates the parameters that need to be checked.



**Parameters to be checked**

- 1) MINIMUM ACCEPTABLE VALUE 2800
- 2) VALUE ≤ 1500
- 3) B - A 2000 MINIMUM ACCEPTABLE VALUE

Perform a further check by inserting a form with a check format code 152136J at the two sides and center of the insertion slot and with its shortest side parallel to the axis of the photosensors. Check for correct operation.

**Note:** The parameters indicated above are useful indications to determine in which operating segment the PR2 E is positioned as far as document acceptance is concerned.

#### **4.4.1.1 PRINTING PHOTSENSOR CALIBRATION VALUES**

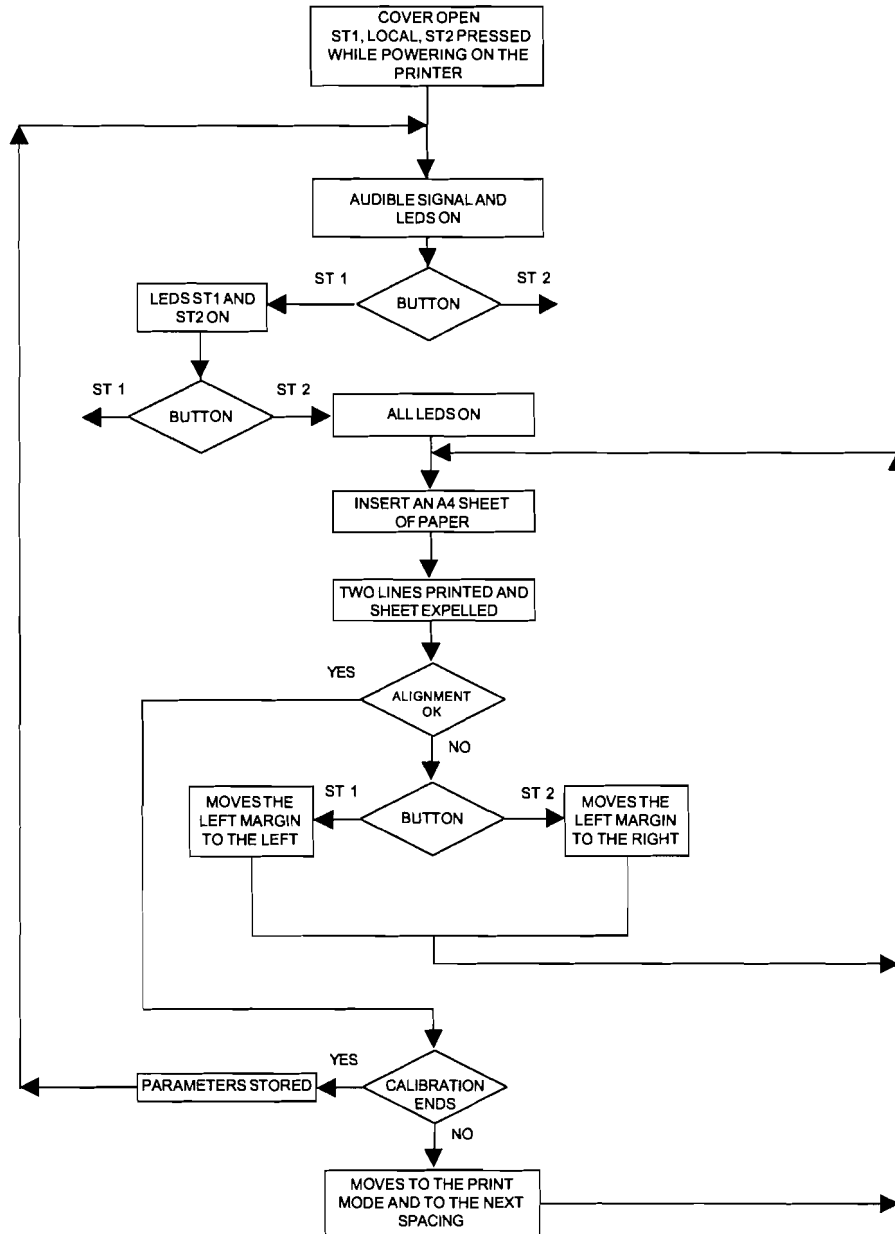
Printing photosensor calibration values is useful as reference between one calibration and the next.

Proceed as follows for alignment calibration:

1. Power on the printer with its cover open and while holding down the three buttons on the console.
2. Wait for the audible signal to sound indicating that the printer has switched to the calibration and adjustment phase, then close the printer cover.
3. Press the STATION 1 button.
4. Press the LOCAL button.
5. When reset is completed, insert an A4 sheet of paper.
6. The sheet is inserted, printed and automatically expelled. The printer automatically switches to the next calibration phase.

#### 4.4.2 BI-DIRECTIONAL PRINT ALIGNMENT CALIBRATION

Provided below is the bi-directional print alignment calibration block diagram.



**Note:** The printer switches between modes and spacings automatically.

Alignment calibration corrects any bi-directional printing misalignment possibly caused by the printer's mechanical tolerances. Bi-directional printing alignment can be optimized by means of a calibration procedure which must be performed for each of the following print modes:

- High Speed Draft            10 cpi
- Draft                            10 cpi
- Draft                            12 cpi
- Near letter quality        10 cpi
- Letter quality                10 cpi

Each print mode has two types of calibration. One type of calibration is for the printing of lines without tabulation stops and the other is for the printing of lines with tabulation stops. For this reason two specific texts will be printed, one for each print mode to be calibrated.

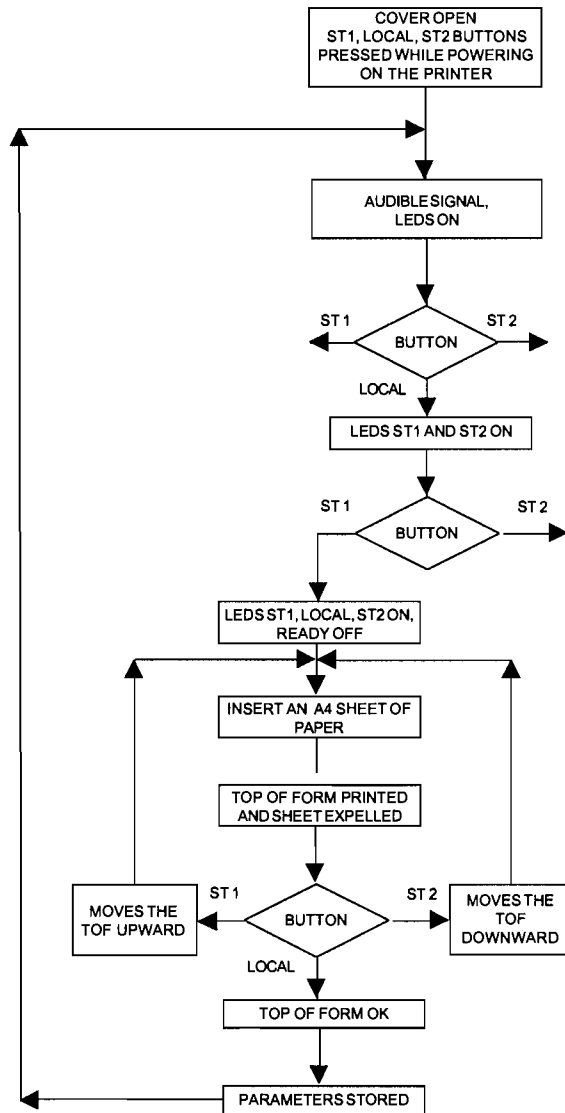
Proceed as follows to calibrate the alignments:

1. Power on the printer with its cover open and while holding down the three console buttons.
2. Wait for the audible signal indicating that the printer has switched to the calibration mode and then close the printer cover.
3. Press the Station 1 button.
4. Press the Station 2 button.
5. The three console buttons are now active. The "Station 1" button activates printing ahead of time while "Station 2" delays printing.
6. Pressing the Station 1 and Station 2 buttons before step 5 stores approximate default values, very close to the correct ones, for all the print modes.
7. Insert an A4 sheet of paper into the front feed slot to check the print alignment status.
8. Press "Station 1" and/or "Station 2" to calibrate the alignments.
9. Repeat steps 7 and 8 cyclically until the calibrations are completed.
10. Press the "Local" button twice to permanently store the alignment setting for the current print mode and to automatically switch to the next adjustment.

Calibration ends when all the print modes are completed or by simultaneously pressing all three console buttons. In both cases the printer will switch to the main menu.

### 4.4.3 TOP OF FORM (TOF) CALIBRATION

Provided below is the Top Of Form (TOF) calibration block diagram.



This calibration sets the distance between the form TOF and the first print line.

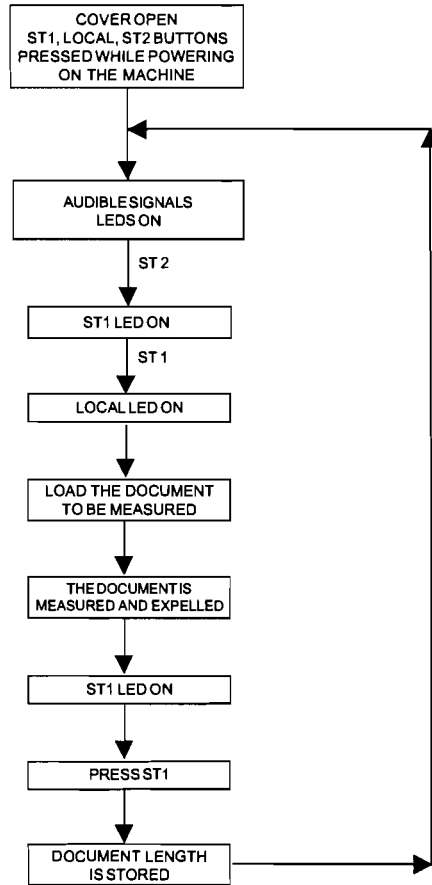
The adjustment can only be activated if the "TOP MARGIN PR40 LIKE" parameter in the PR40+ emulation setup was set to "N".

Proceed as follows to perform this calibration:

1. Power on the printer with its cover open and while holding down the three buttons on the console.
2. Wait for the audible signal indicating that the printer has switched into the calibration and adjustment procedures.
3. Press the Local button and then wait for the printer to complete its reset.
4. Press the Station 1 button; the three console buttons are now active. By pressing Station 1 you can reduce the TOF while by pressing Station 2 you can increase it.
5. Insert an A4 sheet of paper into the front feed slot to check the status of the current TOF. This check is made by printing a specific test. If the current TOF value is too high, printing may occur off the sheet of paper.
6. Press "Station 1" and/or "Station 2" to decrease or increase the TOF.
7. Repeat points 6 and 7 cyclically until the calibrations are complete.
8. Press "Local" twice to permanently store the TOF and to automatically move on to the next calibration.

#### 4.4.4 LEFT PRINT MARGIN CALIBRATION

Provided below is the left print margin calibration block diagram.





This calibration sets the distance between the left edge of the and the first print character.

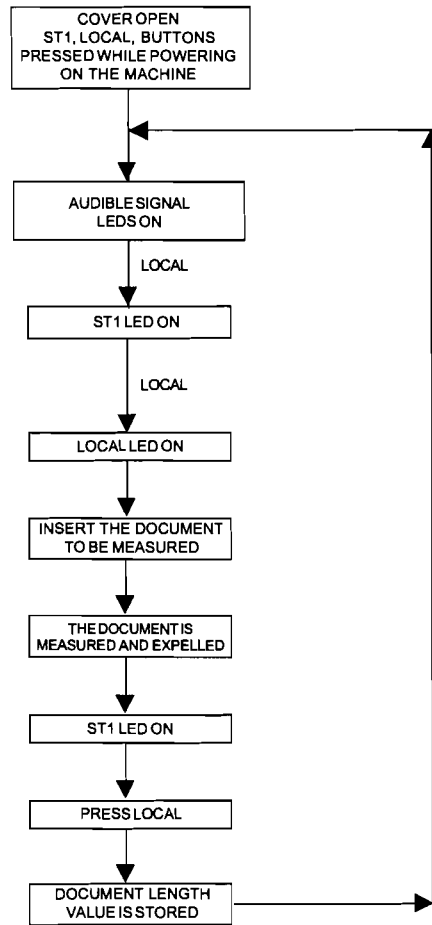
The left margin value will always be used, without the need for set-up configurations.

Proceed as follows to perform this calibration:

1. Power on the printer with its cover open and while holding down the three buttons on the console.
2. Wait for an audible signal to indicate that the printer has switched to the calibration and adjustment mode.
3. Press Local and wait for the machine to complete its reset.
4. Press Station 2.
5. Press the Station 1 button until hearing a prolonged dual-tone signal (different from the previous).
6. Insert an A4 sheet of paper and wait for the printed page. Check that the left margin has the required measurement.
7. The minimum distance between the left edge of the document and the beginning of the character must be a maximum of 0.5 mm with console calibration completely to the left. If this condition is not met, recalibrate the photosensor.
8. Check according to the requirements of step 6.
9. By pressing Station 2, move the left margin rightward until reaching  $6.95 \pm 0.55$  mm defined by the DIMA code 473284Z (check made by inserting an A4 sheet of paper)
10. Press Local twice.

#### 4.4.5 DOCUMENT LENGTH MEASUREMENT

Provided below is the document length measurement block diagram.



Form length measurement is necessary for a rapid handling of a savings book magnetic stripe. By selecting the "STRIPE HANDLING: FAST" set-up option, the value provided by the form measurement procedure will be used to determine the position of the magnetic stripe and to position the stripe above the magnetic head without needing to further measure the length of the savings book. This entails greater time saving during savings book management. For this feature to work correctly the same savings books measured must be used.

Proceed as follows to make this calibration:

1. Power on the printer with its cover open and while holding down the three buttons on the console.
2. Wait for the audible signal indicating that the printer has switched into the calibration and adjustment mode.
3. Press the Local button and wait for the completion of machine reset.
4. Insert an A4 sheet of paper into the front insertion slot and then press Station 1. The sheet will be inserted and expelled automatically.
5. If necessary, repeat step 5.
6. Press Local twice to permanently store the form length value measured and to automatically switch to the next calibration.

#### 4.4.6 SKEW AND SIGNAL AMPLITUDE CONTROL

This check must be performed with the machine completely assembled and after having configured and specified, during set-up, the magnetic device installed on the printer.

The signal source must be exclusively the following card:

- AMPLITUDE AND SKEW SAMPLE code 713483R for horizontal magnetic unit.

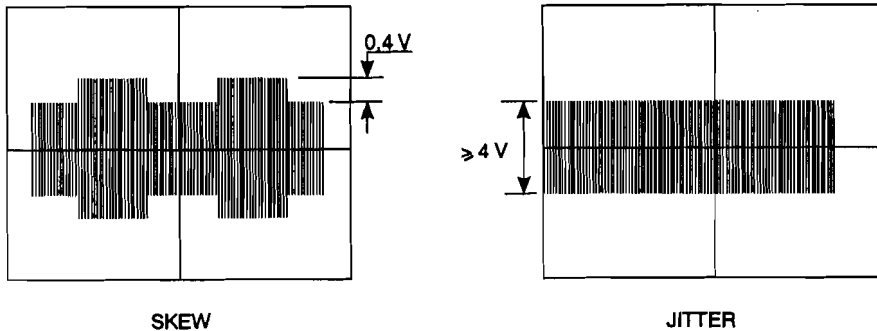


Fig. 4-2

Using an oscilloscope with memory, proceed as follows:

- Insert the "Amplitude and Skew Sample" chart code 751884Z into the front feed slot from the Skew Control side. Record the signal read when the printhead moves from right to left. The signal recorded must not have a spread greater than 0.4V. No action is required.
- Insert the "Amplitude and Skew Sample" chart code 751884Z into the front feed slot from the Jitter/Ampl. side. Record the signal read when the printhead moves from right to left. If the signal recorded does not reach the value of 4V, replace the printhead.

#### 4.4.7 SIGNAL AMPLITUDE CONTROL

This control must be performed in the same way as the previous. Insert a sample chart so that the jitter and amplitude of the sample stripe are read. The printer will perform a read cycle before expelling the chart. Using an oscilloscope with memory, check the amplitude of the signal read which must be uniform and must have a value of no less than 4V peak-to-peak.

The check must be made when the printhead moves from right to left within the horizontal magnetic reader.

## **5. PRODUCT DIAGNOSIS**

### **5.1 SERVICING MODES**

The following pages provide a technical approach to servicing that could be useful to less experienced field engineers.

#### **5.1.1 FAULT DETECTION ANALYSIS**

The user who detected product malfunction can give information regarding the operating mode the printer was in when the malfunction occurred and the related error indications that were provided.

The repetition of the fault, when possible, can help with its identification.

For fault diagnosis purposes, it is important to establish whether the fault is repetitive or random.

#### **5.1.2 ANALYSIS OF THE OPERATING CONDITIONS**

##### ***WORK ENVIRONMENT***

An environment that is too cold, hot or humid could be the cause of certain malfunctions.

The machine must not be positioned near air conditioning system vents or exposed to direct sun light.

Make sure that the machine's internal ventilation slots are not blocked, especially if the printer is installed in furniture.

Forms, documents or office equipment located .

##### ***ACCESSORIES AND FORMS***

Make sure that the accessories installed in the machine are originals and in good condition.

Check that the documents inserted in the printer comply with the machine specifications and are in good condition.

##### ***PRINTER OPERATING CONDITION***

Check that the internal parts of the machine have no dirt deposited or residue of paper or ink that could interfere with the performance of the printer's different components.

Make sure there is no internal damage caused by the insertion of documents with metal clips, staples, pins or similar.

Ensure that the parts specified are correctly lubricated.

### **5.1.3 IDENTIFYING THE MALFUNCTION**

Carefully examine all the information collected (from the Operator, printer error signals, analysis of the documents where the fault has occurred, repetition of the error when the machine is powered on, etc.) to recognize and identify the machine malfunction to be corrected.

At times a malfunction is generated by more than one cause: it is important in such cases to isolate the faults and deal with them one at a time.

### **5.1.4 FINDING THE CAUSE**

Using experience together with the information given in this section as a guide, take a logical path to find the fault, starting from the most probable cause through to the most remote possibility until faulty part is found.

### **5.1.5 SOLVING THE PROBLEM**

Repair the machine so that it correctly resumes to operate as normal.

The information provided in Chapters 6, 7, 8 and 9 can be of help.

### **5.1.6 TESTING THE MACHINE**

When the repair is completed, give the machine a general cleaning and then run a complete test on the machine (section 3.5), possibly with the Operator present, to make sure that the malfunction has been corrected and that no others have occurred in the mean time.

## 5.2 FAULT CLASSIFICATION

To make the search easier, the faults have been classified as follows:

- 5.3            Power-on faults
- 5.4            Document write faults
- 5.5            Document handling faults
- 5.6            Magnetic stripe read/write faults

Each fault classification lists the more probable failures and their possible causes.

The classification provided in this chapter cannot cover all the faults that could occur on the machine; if the fault detected is not described herein, refer to the description of a similar fault.

### 5.3 POWER ON FAULTS

<div style="text-align: center;"> <b>FAULT</b>  <hr/> <b>POSSIBLE CAUSE</b> </div>	The printer does not power on	Autodiagnosics indicate a main board failure	Autodiagnosics indicate a mechanical failure	The printer is unable to connect with the system
Incorrect/missing line voltage	<b>X</b>			
Damaged power cord	<b>X</b>			
Power cord partly inserted	<b>X</b>			
Blown fuse	<b>X</b>			
Faulty power supply unit	<b>X</b>			
Faulty main board		<b>X</b>		<b>X</b>
Faulty front photosensors			<b>X</b>	
Faulty carriage photosensor			<b>X</b>	
Faulty rear photosensor			<b>X</b>	
Printer cover open			<b>X</b>	
Jammed paper			<b>X</b>	
Interface connection problems				<b>X</b>
Interface line problems				<b>X</b>
Incorrect set-up				<b>X</b>



## 5.4 DOCUMENT WRITE FAULTS

<div style="text-align: center;">FAILURE</div> <div style="text-align: center;">POSSIBLE CAUSE</div>	Printhead does not write	Faded printing	Stained printing	Incomplete printing	Unaligned printing	Deformed printing with irregular spacing
Ribbon cartridge not installed	X	X				
Ribbon to be replaced (finished)		X				
Ribbon cartridge fitted incorrectly	X	X		X		
Incorrect set-up parameters					X	X
Obstruction along the carriage stroke	X					X
Closing levers open	X	X		X	X	
Faulty printhead	X			X		
Faulty paper photosensor	X				X	X
Faulty head flat cable	X			X	X	X
Transport motor	X					X
Faulty main board	X			X		
Paper feed belt adjustment					X	
Needle-platen distance adjustment	X	X	X	X		
Ribbon-needle protection fin adjust.	X	X	X	X		
Paper photosensor adjustment	X				X	X
Print bar adjustment	X	X				
Strap adjustment					X	
Roller gear adjustment					X	
Front pressure roller adjustment					X	
Carriage movement belt adjustment					X	X

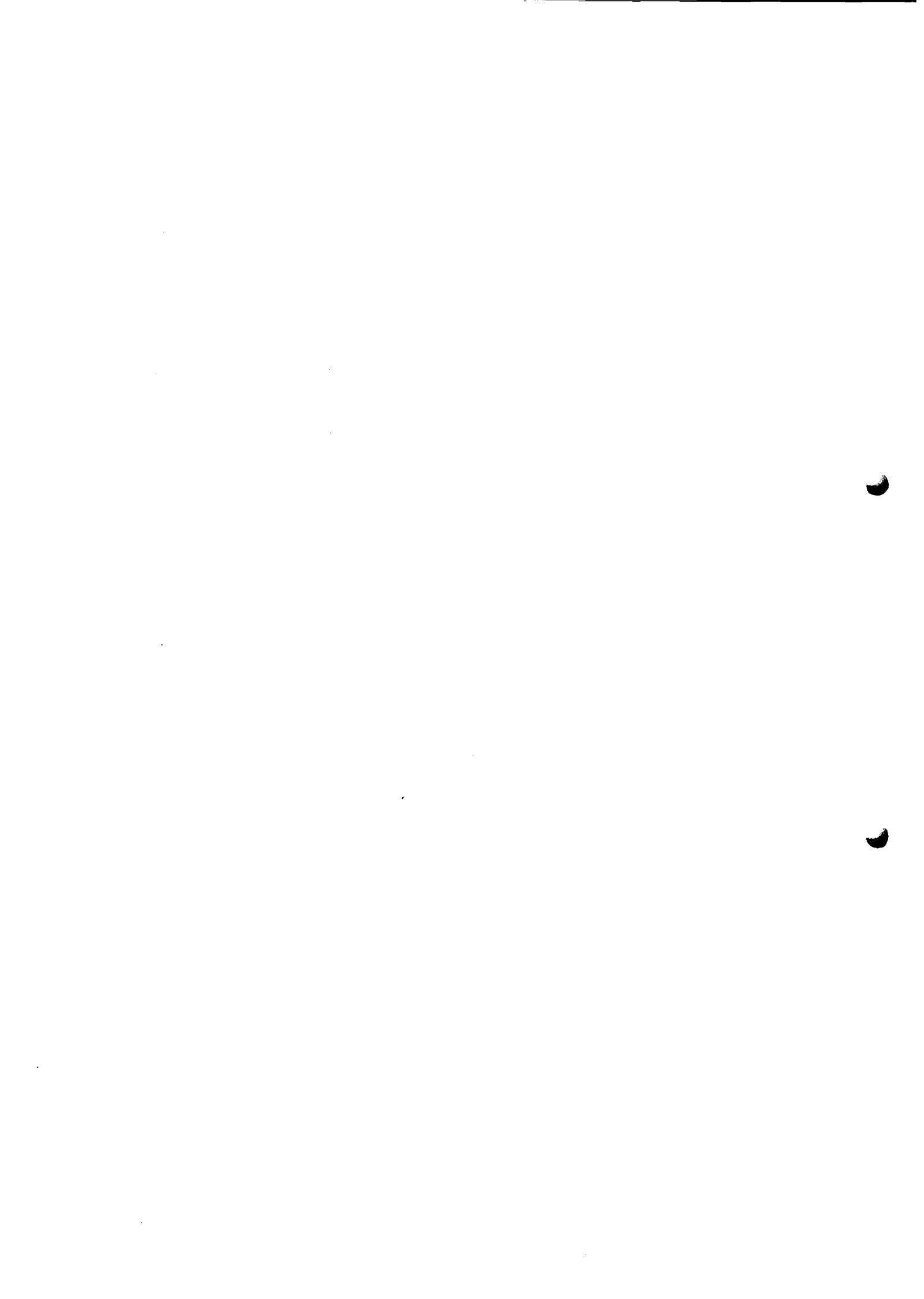
## 5.5 DOCUMENT HANDLING FAULTS

<div style="text-align: center;">FAILURE</div> <div style="text-align: center;">POSSIBLE CAUSE</div>	The printer does not load/ expel the document	The document is moved crookedly	The document is crumpled	The document has irregular line feeds
Document not within specifications	X	X	X	X
Ruined document	X	X	X	X
Closing levers open		X	X	X
Faulty front photosensors	X			
Faulty paper photosensor	X			
Faulty rear photosensor	X			
Faulty services motor	X			
Faulty paper feed motor	X			X
Faulty main board	X			
Document feed belt adjustment			X	
Needle-platen distance adjustment			X	
Ribbon-needle protection fin adjustment			X	
Paper photosensor adjustment	X		X	
Print bar adjustment			X	
Strap adjustment			X	
Roller gear adjustment				X
Front pressure roller adjustment				

## 5.6 MAGNETIC STRIPE READ/WRITE FAILURES

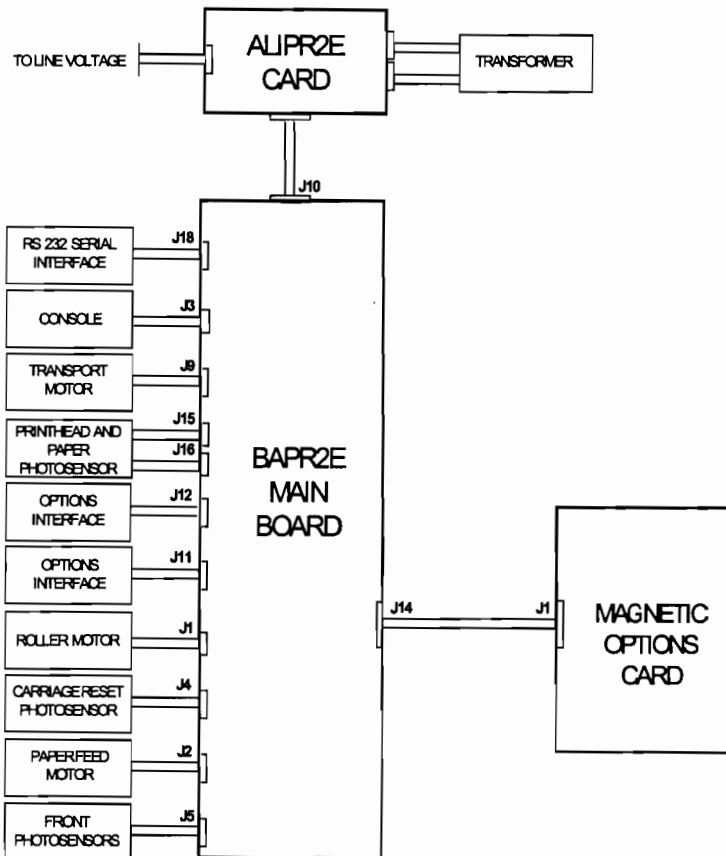
<div style="text-align: center;"> <p><b>FAILURE</b></p> <p><b>POSSIBLE CAUSE</b></p> </div>	<div style="writing-mode: vertical-rl; transform: rotate(180deg);"> <p>Horizontal magnetic device read/write errors</p> </div>
Incorrect set-up	<b>X</b>
Ruined savings book	<b>X</b>
Incorrect savings book insertion	<b>X</b>
Dirty magnetic head	<b>X</b>
Faulty magnetic head	<b>X</b>
Faulty paper feed motor	<b>X</b>
Faulty magnetic device card	<b>X</b>
Faulty main board	<b>X</b>
Faulty magnetic head movement motor	<b>X</b>





## 6. ELECTRICAL INTERCONNECTIONS

### 6.1 GENERAL PRINTER INTERCONNECTION DIAGRAM



## 6.2 BAPR2 MAIN BOARD

The BAPR2 main board has an onboard serial interface. The printer can be configured with one of the following two interface cards:

- RS232 serial + UBS
- Centronics parallel.

### 6.2.1 MAIN BOARD VIEW AND LOCATION OF CONNECTORS

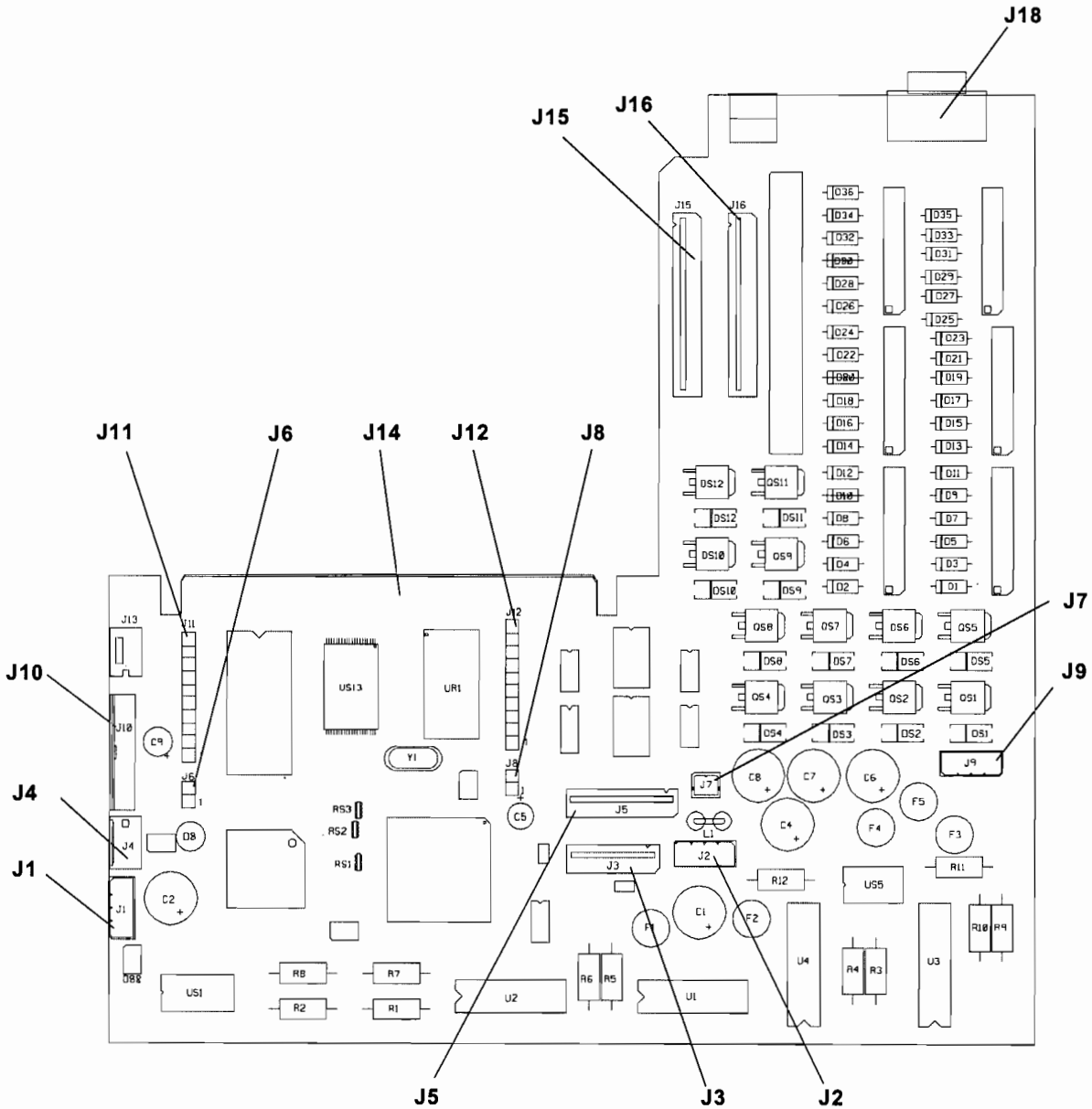


Fig. 6-1 Main Board on the PR2 E

### 6.2.3 CONNECTOR PIN-OUT

Provided below are the pinouts of the connectors on the PR2 E main board. Connector J33 is not indicated since it is only present on the BAPR2E Cost Improvement version.

**J18**  
(RS 232 INTERFACE)

1	DCD1
2	RX01
3	TX01
4	DTR1
5	GND
6	DSR1
7	RTS1
8	CTS1
9	TERRSE

**J3**  
(CONSOLE)

1	GND
2	P5CONS
3	LED3
4	LEDLOC
5	LED2
6	LED1
7	LEDON
8	TAS01
9	TALOC
10	TAS02
11	COPEN
12	GND

**J10**  
(POWER SUPPLY)

1	PIU35
2	PIU35
3	GND
4	GND
5	GND
6	VCC
7	PIU12
8	MEN12
9	RESE0

**J9**  
(TRANSPORT MOTOR)

1	FASEA
2	FASEB
3	FASEC
4	FASED

**J15**  
(PRINTHEAD CONNECTOR)

1	TESTE
2	LEBCA
3	FOBCA
4	VCCTES
5	R0224
6	SPL(2)
7	R0422
8	SPL(4)
9	R0620
10	SPL(6)
11	R1214
12	SPL(12)
13	R0717
14	SPL(17)
15	R1113
16	SPL(13)
17	R1113
18	SPL(11)
19	R0519
20	SPL(5)
21	R0422
22	SPL(22)
23	R0123
24	SPL(23)
25	R0519
26	SPL(19)

**J16**  
(PRINTHEAD CONNECTOR)

1	R0818
2	SPL(8)
3	R1016
4	SPL(10)
5	R1214
6	SPL(14)
7	R0818
8	SPL(18)
9	R1016
10	SPL(16)
11	R0915
12	SPL(15)
13	R0915
14	SPL(9)
15	R0717
16	SPL(7)
17	R0321
18	SPL(3)
19	R0123
20	SPL(1)
21	R0620
22	SPL(20)
23	R0224
24	SPL(24)
25	R0321
26	SPL(21)

**J4**

(CARRIAGE RESET)

1	VCC
2	VCC
3	GND
4	FAZCA

**J2**

(PAPER FEED MOTOR)

1	TRF1A
2	TRF1B
3	TRF2A
4	TRF2B

**J1**

(ROLLERS MOTOR)

1	MR01A
2	MR01B
3	MR02A
4	MR02B

**J12**

(OPTIONS)

1	MAC21
2	MAC20
3	MAC11
4	MAC10
5	MAPH2
6	MAPH1
7	PIU35
8	PIU35
9	GND
10	GND

**J6**

(OPTIONS)

1	ADSEL
2	FDCDM

**J6**

(OPTIONS)

1	TXDS
2	SCKDS

**J99**

(FRONT PHOTOSENSORS)

1	FOCOM
2	VCCAL2
3	LECOM
4	LEAL3
5	LECOM
6	FOCOM
7	VCCAL4
8	FOAL3
9	VCC
10	FOAN2
11	LEAN2
12	LEAN1
13	FOAL1
14	FOAN1
15	LEAL1

**J11**

(OPTIONS)

1	VCC
2	CKMOT
3	DACOM
4	FAZMA
5	PMAGN
6	VERMA
7	RESE0
8	F2FDA
9	PIU12
10	GND

**J1**

(INTERFACE)

AD (15)	32	1	GND
AD (13)	33	2	AD (14)
AD (11)	34	3	AD (10)
AD (9)	35	4	AD (12)
AD (7)	36	5	AD (8)
AD (5)	37	6	AD (6)
AD (3)	38	7	AD (4)
AD (1)	39	8	AD (2)
DA (7)	40	9	AD (0)
DA (5)	41	10	DA (6)
DA (3)	42	11	DA (4)
DA (1)	43	12	DA (2)
ASTB0	44	13	DA (0)
WRITE	45	14	WAIT0
INTCX	46	15	READ0
RDOSP	47	16	CKMOT
CSEXP	48	17	WROSP
GPI00T	49	18	
STROB	50	19	BUSY1
DACX (7)	51	20	ACK00
DACX (5)	52	21	DACX (6)
DACX (3)	53	22	DACX (4)
DACX (1)	54	23	DACX (2)
IMPRA	55	24	RESUSB
ESTR2	56	25	SELRSUS
ESTR1	57	26	SUSPUSB
GND	58	27	PESTR
VCC	59	28	RESE0
VCC	60	29	MEN12
GND	61	30	PIU12
PIU35	62	31	GND



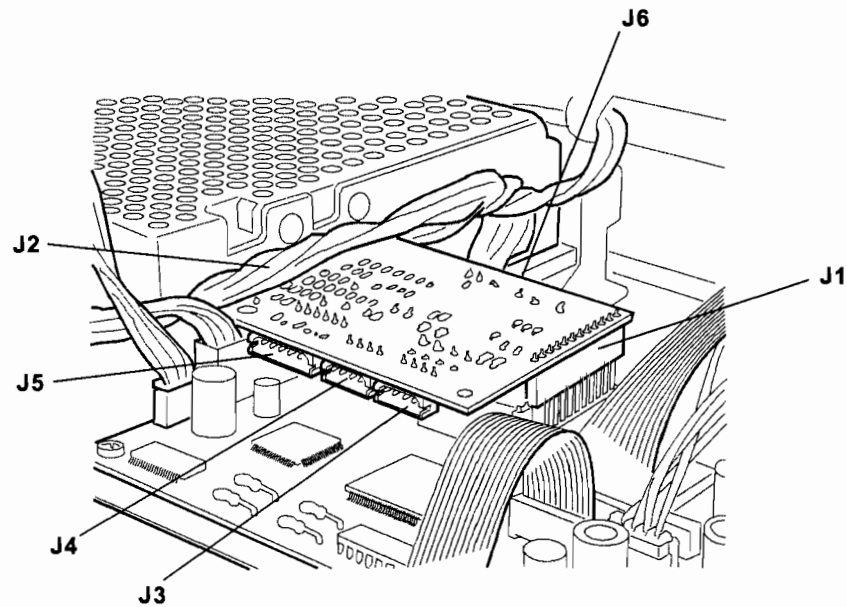
### 6.3 MAGNETIC OPTIONS CARD

The following magnetic options card can be installed on the BAPR2 main board:

- PR2MAGN, for the management of the horizontal magnetic device option

The option installed is controlled by the FW according to the parameters defined during machine setup.

#### 6.3.1 CARD LOCATION AND IDENTIFICATION OF CONNECTORS



*Fig. 6-2 Magnetic Options Card*

### 6.3.2 VIEW OF THE PR2MAGN CARD

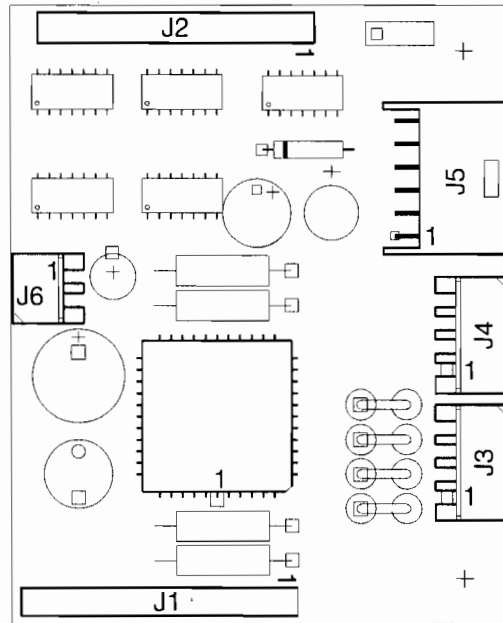


Fig. 6-3 PR2MAGN Card

### 6.3.2.1 PR2MAGN CARD PIN-OUT

#### J1

(CONNECTION TO THE MAIN BOARD)

1	MAC21
2	MAC20
3	MAC11
4	MAC10
5	MAPH2
6	MAPH1
7	PIU35
8	PIU35
9	GND
10	GND

#### J2

(CONNECTION TO THE MAIN BOARD)

1	VCC
2	DAWRM
3	DACOM
4	FAZMA
5	GND
6	VERMA
7	RESE0
8	F2FDA
9	PIU12
10	GND

#### J3

(MAGNETIC DEVICE MOTOR)

1	FAM0
2	FAM1
3	FAM2
4	FAM3

#### J4

(MAGNETIC RESET PHOTO.)

1	VCC
2	VCC
3	LED1
4	FAZZ0

#### J5

(MAGNETIC HEAD)

1	WRI1
2	WRI0
3	GND
4	GND
5	LEO1
6	LEO0

#### J6

(CALIBRATIONS)

1	OUT1
2	GND

## 6.4 SERIAL AND USB INTERFACE CARD

The installation of this interface card provides the printer with an additional serial RS232 and USB interface.

### 6.4.1 CARD VIEW AND LOCATION OF CONNECTORS

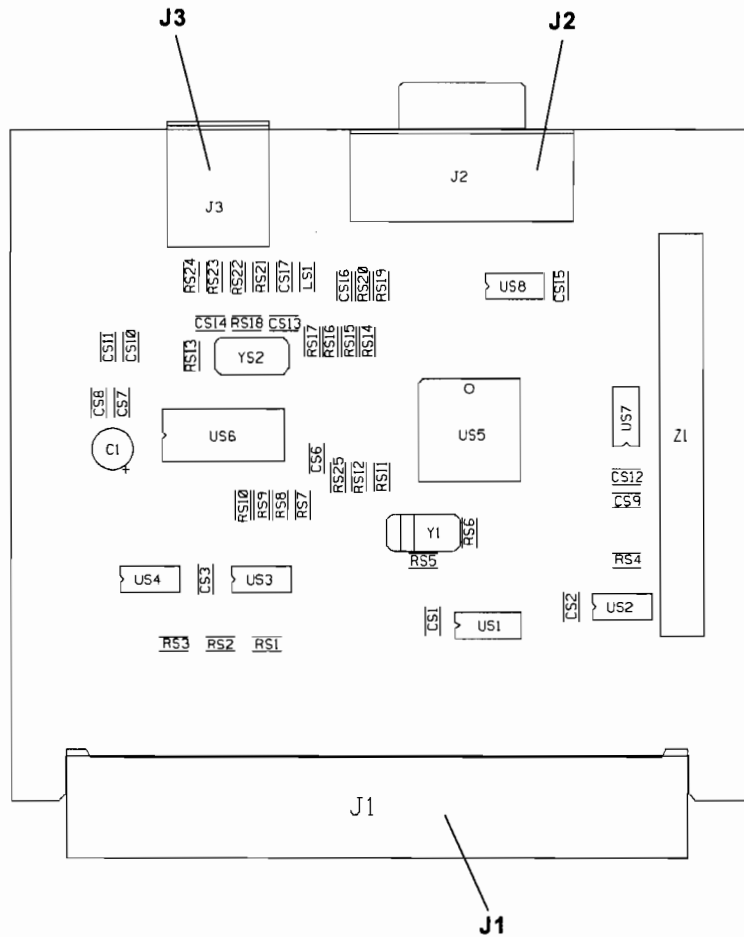


Fig. 6-4 SERIAL and USB Interface Card

## 6.4.2 CONNECTOR PIN-OUT

Provided below is the pinout of the connectors on this interface card.

<b>J2</b>		<b>J2</b>	
<b>(RS232 SERIAL INTERFACE)</b>		<b>(USB INTERFACE)</b>	
1	DCD1	1	VBUS
2	REXD1	2	DMENO
3	TXD1	3	DPIU
4	DTR1	4	GND
5	GND		
6	DSR1		
7	CTS1		
8	TAS01		
9	TERRSE		

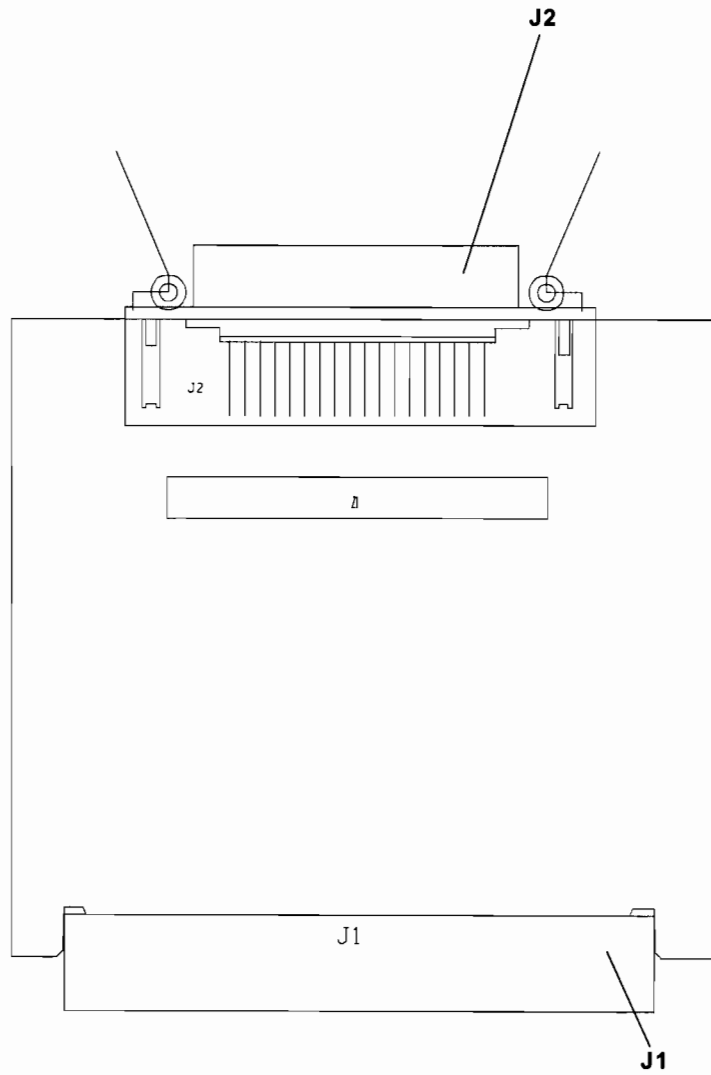
  

<b>J1</b>			
<b>(INTERFACE)</b>			
AD (15)	32	1	GND
AD (13)	33	2	AD (14)
AD (11)	34	3	AD (10)
AD (9)	35	4	AD (12)
AD (7)	36	5	AD (8)
AD (5)	37	6	AD (6)
AD (3)	38	7	AD (4)
AD (1)	39	8	AD (2)
DA (7)	40	9	AD (0)
DA (5)	41	10	DA (6)
DA (3)	42	11	DA (4)
DA (1)	43	12	DA (2)
ASTB0	44	13	DA (0)
WRITE	45	14	WAITO
INTCX	46	15	READO
RDOSP	47	16	CKMOT
CSEXP	48	17	WROSP
GPI00T	49	18	
STROB	50	19	BUSY1
DACX (7)	51	20	ACK00
DACX (5)	52	21	DACX (6)
DACX (3)	53	22	DACX (4)
DACX (1)	54	23	DACX (2)
IMPRA	55	24	RESUSB
ESTR2	56	25	SELRSUS
ESTR1	57	26	SUSPUSB
GND	58	27	PESTR
VCC	59	28	RESE0
VCC	60	29	MEN12
GND	61	30	PIU12
PIU35	62	31	GND

## 6.5 PARALLEL INTERFACE CARD

The installation of this interface card provides the printer with a Centronics parallel interface.

### 6.5.1 CARD VIEW AND LOCATION OF CONNECTORS



*Fig. 6-5 Parallel Interface Card*

## 6.5.2 CONNECTOR PIN-OUT

Provided below is the pinout of the connectors on this interface card.

<b>J2</b>			<b>J1</b>				
<b>(PARALLEL INTERFACE)</b>			<b>(MAIN BOARD INTERFACE)</b>				
	19	GND	AD (15)	32	1	GND	
STROBX	1	20	GND	33	2	AD (14)	
DACXX(0)	2	21	GND	34	3	AD (10)	
DACXX(1)	3	22	GND	AD (9)	35	4	AD (12)
DACXX(2)	4	23	GND	AD (7)	36	5	AD (8)
DACXX(3)	5	24	GND	AD (5)	37	6	AD (6)
DACXX(4)	6	25	GND	AD (3)	38	7	AD (4)
DACXX(5)	7	26	GND	AD (1)	39	8	AD (2)
DACXX(6)	8	27	GND	DA (7)	40	9	AD (0)
DACXX(7)	9	28	GND	DA (5)	41	10	DA (6)
ACKX	10	29	GND	DA (3)	42	11	DA (4)
BUSYX	11	30	GND	DA (1)	43	12	DA (2)
PAPEMP	12	31	IMPRAX	ASTB0	44	13	DA (0)
SELOUT	13	32	FAULTCX	WRITE	45	14	WAIT0
AUTOLF	14	33	GND	INTCX	46	15	READ0
-	15	34	-	RDOSP	47	16	CKMOT
GND	16	35	TIR00	CSEXP	48	17	WROSP
TERRCX	17	36	SELINP	GPI00T	49	18	
VCC	18	37	TERRCX	STROB	50	19	BUSY1
		38	GND	DACX (7)	51	20	ACK00
				DACX (5)	52	21	DACX (6)
				DACX (3)	53	22	DACX (4)
				DACX (1)	54	23	DACX (2)
				IMPRA	55	24	RESUSB
				ESTR2	56	25	SELRSUS
				ESTR1	57	26	SUSPUSB
				GND	58	27	PESTR
				VCC	59	28	RESE0
				VCC	60	29	MEN12
				GND	61	30	PIU12
				PIU35	62	31	GND

## 6.6 CONSOLE

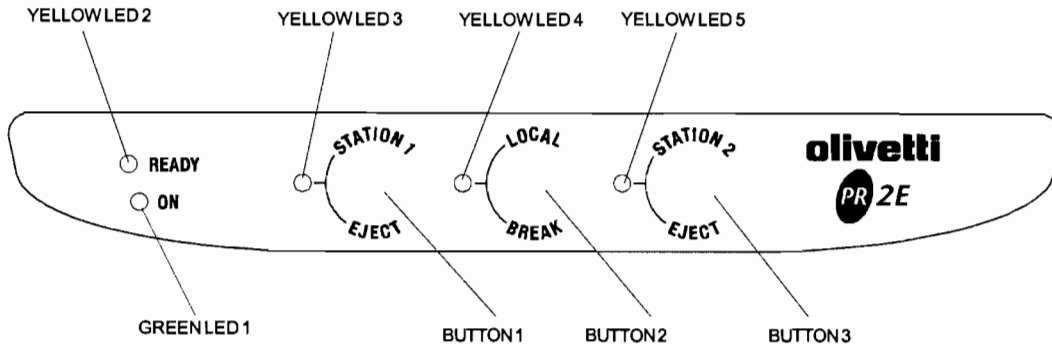


Fig. 6-6 Console

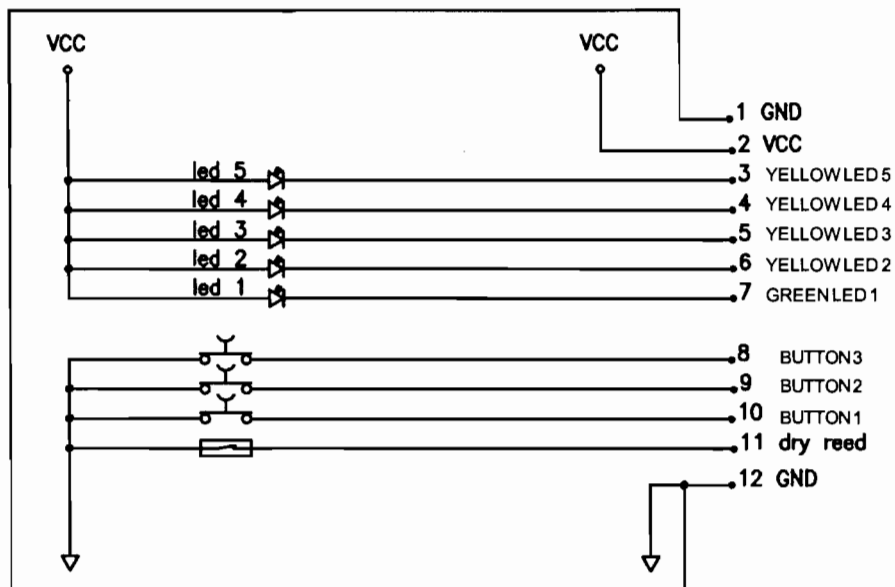


Fig. 6-7 Console Electrical Diagram



## 6.7 ALIPR2E CARD

Two codes can be assigned to the ALIR2 card depending on the line voltage supported (115 V or 230 V). Also the value of fuse F1 varies according to the line voltage.

### 6.7.1 CARD VIEW AND LOCATION OF CONNECTORS

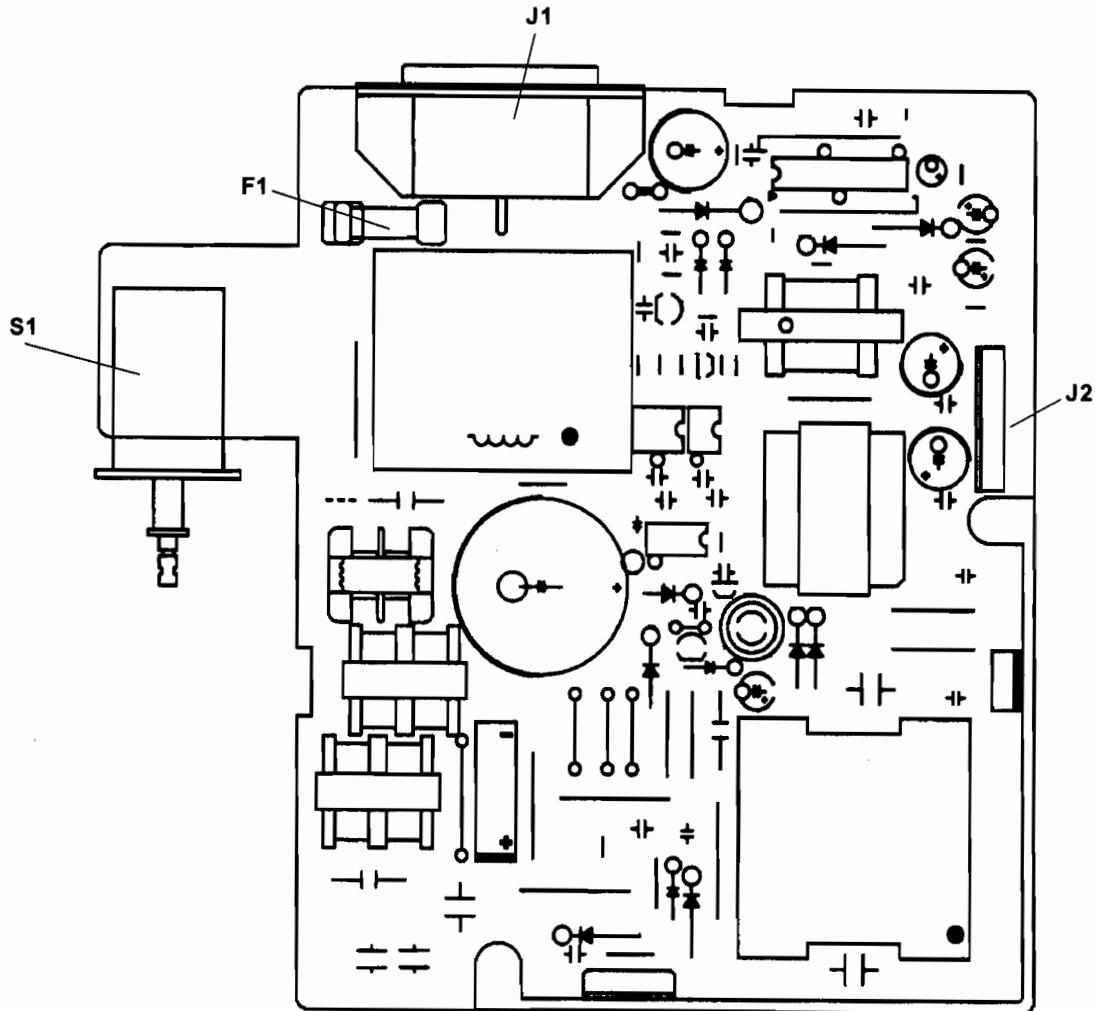


Fig. 6-8 ALIPR2 Card

### 6.7.2 CONNECTOR PIN-OUTS AND FUSE

**J1**  
(EXTERNAL POWER SUPPLY)

1	VAC
2	GND
3	VAC

F1 Fuse: 250V 3.15A

**J2**  
(MAIN BOARD POWER SUPPLY)

1	ROUT
2	-12V
3	+12V
4	+5V
5	GND
6	GND
7	GND
8	35V
9	35V



## **7. PREVENTIVE MAINTENANCE**

### **7.1 CLEANING**

For a correct printer operation, it is suggested that the internal components of the machine be cleaned periodically and whenever the machine is serviced.

#### **7.1.1 CLEANING THE CASE**

Power off the machine, unplug it from the electrical outlet and then clean its case using a damp cloth; avoid using corrosive substances such as solvents, alcohol solutions, petrol or abrasive components.

#### **7.1.2 CLEANING THE PAPER PATHS**

Clean all the document paths including the paper feed rollers of the front paper feeder, making sure to remove any paper or ribbon residues that are deposited on the parts. Also remove any foreign matter.

#### **7.1.3 CLEANING THE MAGNETIC READ HEAD**

Clean using the specific card (code 751498E) provided with the machines equipped with the horizontal magnetic + MICR device.

Cleaning can be performed either automatically or manually by the field engineer.

#### ***AUTOMATIC CLEANING***

By means of a specific SW routine, the system informs the operator that cleaning is necessary and engages in a dummy magnetic transaction.

If not provided by the system, the cleaning instructions are indicated on the cleaning card.

The automatic cleaning procedure is usually performed directly by the operator.

## MANUAL PROCEDURE

This cleaning procedure is performed by the field engineer and is not included in the programmed maintenance scheduled by the automatic procedure.

Also in this case you need to run a system command for a magnetic stripe read operation.

Insert the cleaning card in the front feed slot making sure to position it correctly: the machine will attempt to read the card after which it expels the card and signals an error condition.

Power the machine off and then on again to resume its normal operating status.

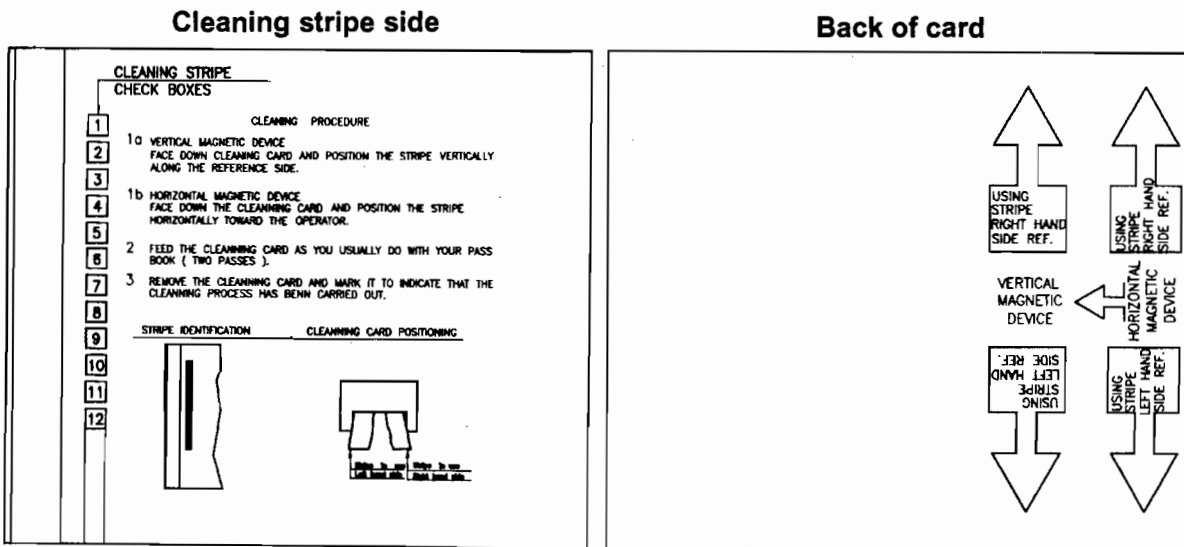


Fig. 7-1 Magnetic Head Cleaning Card

## 7.2 MAINTENANCE

Inside the machine, to the right-hand side, there is a brush which is used to clean the paper edge detection photosensor located behind the printhead. This brush has a life span equivalent to that of the printhead. If, in exceptional cases, the paper photosensor becomes dusty it is suggested that you replace the cleaning brush.

## 7.3 LUBRICATION

Although machine lubrication is not scheduled throughout its entire life span, during each service call you are expected to check the lubrication of the different parts by referring to the lubrication points table indicated below.

### 7.3.1 LUBRICATION POINTS ON THE BASIC MACHINE

DESCRIPTION	CODE	GREASE	OIL
Printhead carriage slide shafts			X
Carriage felt	473150E		X
Ribbon feed gear assy	X		
Cam, in the contact area with: reed support pin, pressure bridge roller	473072X 473076T 473074Z	X X X	
Hole of the contact bushing between roller shaft and strap shaft	473170A 473171X	X X	
Center pressure device in shaft contact area	473167T	X	
Bushings in the shaft contact area	473087P 474953Y	X X	
Motor gear, gear and cam teeth assembly gear	473069C 473071W 473072X 473174S 473180V	X X X X X	
Pulley toothing	473017Q	X	
Hooking area leaf spring	473182K	X	
Ribbon feed rotation pin hole with support pin	473159B	X	
Belt tightener pin with return pulley	473149H	X	
Alignment rollers shaft assy in torsion bar contact area in conveyor assy guideway area	474987K 473091K 473186P 474951W	X	
Rubber in the damper assembly hole	475871K	X	

Grease: Code 150337 M MAGNALUBE - E

Oil: Code 757283 C - FOMBLIN Y 06 oil (perfluorate polyether)  
Supplier: Ausimont, a Montedison group company

DESCRIPTION	CODE	GREASE	OIL
Print crosspiece in the following areas:	395115R	X	
Left pin and ballast	473049G	X	
Guide hole center pin		X	
Pin contact left bracket		X	
Inside the crosspiece adjustment screw holes		X	

### 7.3.2 HORIZONTAL MAGNETIC DEVICE/MICR LUBRICATION POINTS

DESCRIPTION	CODE	GREASE	OIL
Upper carriage slide shaft (with moderation, placing a drop at the sides of the shaft)			X
Return pulley, between pin and roller cage		X	
Door, on rotation pins		X	
Sector gear, on its own pin		X	
Sector-door conical copling gear		X	
Inclined plane of the carriage in the door closing lever control area		X	
Inside the pressure control cam		X	

Grease: Code 150337 M MAGNALUBE - E

Oil: Code 757283 C - FOMBLIN Y 06 oil (perfluorate polyether)  
Supplier: Ausimont, a Montedison group company

## 8. MECHANICAL ADJUSTMENTS

For easier consultation purposes, the mechanical adjustments have been divided into:

- **Machine condition.** Describes the condition that the printer must be in in order to be able to perform a successful adjustment.
- **Objective adjustment.** Indicates the points, values and tolerances to be observed to ensure good kinematic operation.
- **Procedure.** Describes the operations to be performed for the adjustment.
- **Notes.** Indicates any reference to adjustment sequences or to tests to be performed once the adjustment is made.

## 8.1 DOCUMENT FEED BELT ADJUSTMENT

### **MACHINE CONDITION:**

Unimportant.

### **OBJECTIVE ADJUSTMENT:**

The tension of timing belt (1) must sag  $2.9 \pm 2$  mm when applying  $200 \text{ gr} \pm 2$  gr at the center of the lower span.

### **PROCEDURE:**

Loosen the motor securing nuts (2), tighten the belt accordingly and then tighten nuts (1) again.

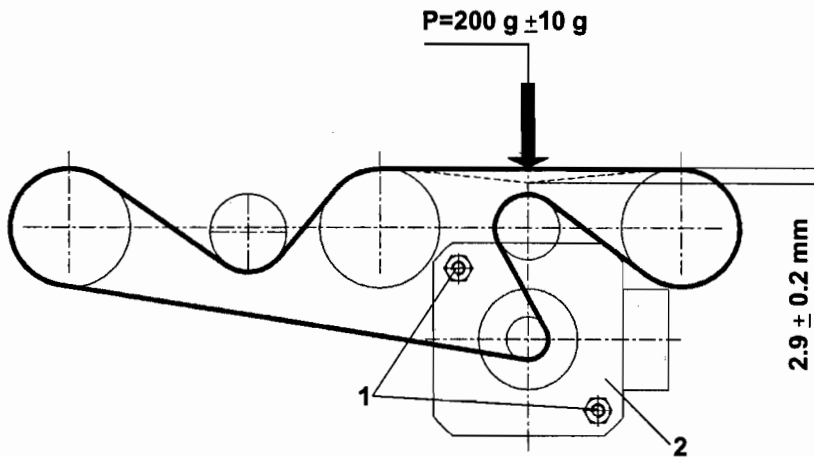


Fig. 8-1



## 8.2 PRINT BAR ADJUSTMENT

### **MACHINE CONDITION:**

Testina di stampa posizionata coassiale con l'asse della vite su cui si compie la regolazione.

### **OBJECTIVE ADJUSTMENT:**

A distance of 0.4/0.5 mm must be measured between the frame's lower shield (1) and the head of screw (2).

### **PROCEDURE:**

While holding the printhead carriage on the axis, adjust screw (2) until measuring the required distance. Repeat this procedure on the other screw located on the opposite side of the frame.

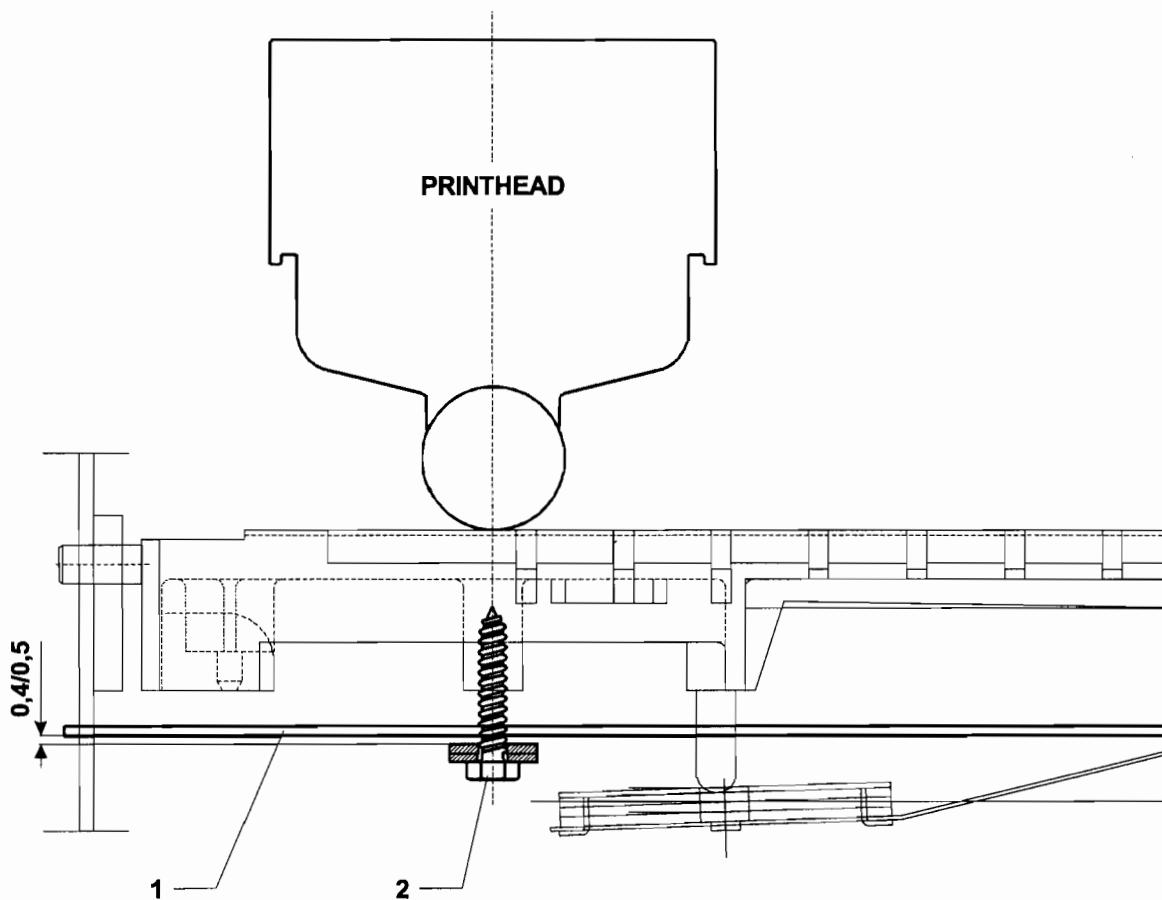


Fig. 8-2

### 8.3 PARALLELISM ADJUSTMENT BETWEEN THE PRINT BAR AND LEAF SPRING LOAD IN THE BASIC MACHINE

**MACHINE CONDITION:**

Machine powered off and with the case removed.

**OBJECTIVE ADJUSTMENT:**

Parallelism between the print bar and leaf spring load.

**PROCEDURE:**

The print bar perpendicularity adjustment lever must be previously adjusted using tool code 9600303 according to drawing code 395130U.

To manually adjust the parallelism between the printhead and print bar, loosen studs (2) and turn counterclockwise to move the print bar closer to the front of the matrix; turn clockwise, instead, to move the bar closer to the rear of the matrix.

You can use parallelism indicator (3) to check whether corrections have been made.

To change the load of the spring leaf, turn adjustment nuts (4).

Move the carriage all the way to the left and, using a comparator, with a dynamometer push the print bar near the probe roller. A displacement of 0.4-0.5 mm must correspond to a load of 280 gr  $\pm$  20 gr. Repeat this procedure on the right-hand side of the print bar.

When adjustment is complete, secure using securing nuts (5).

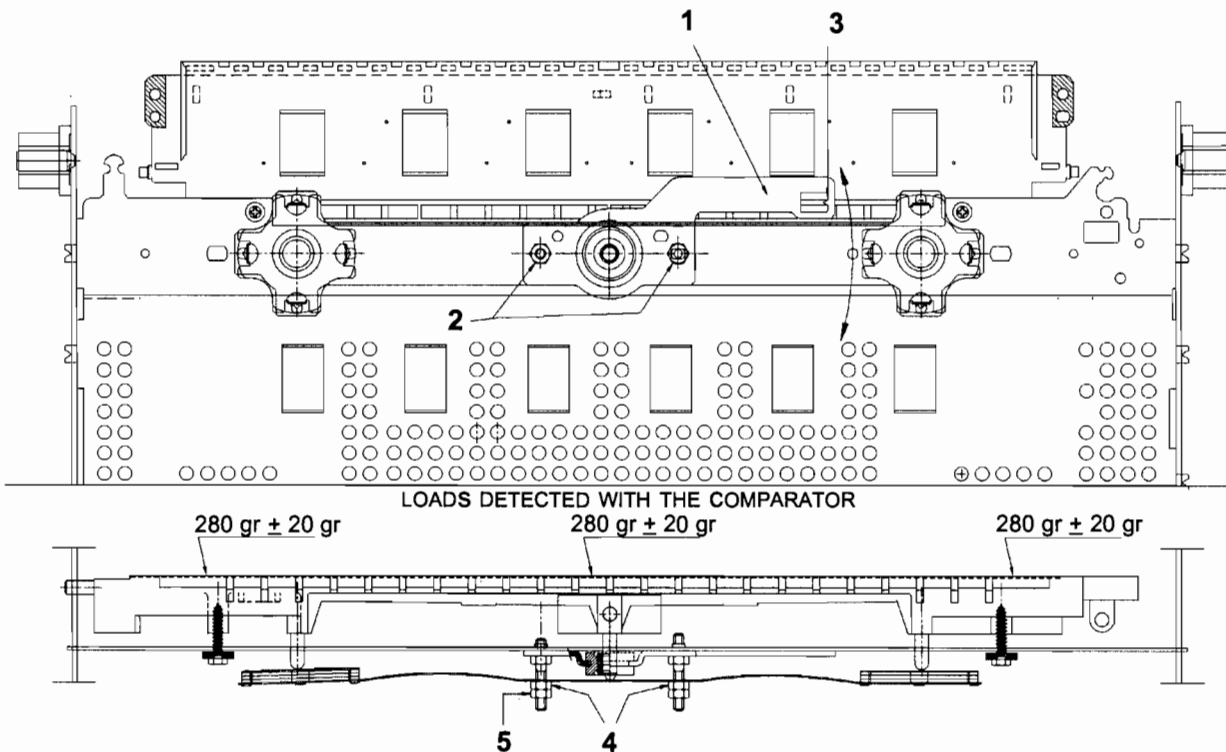


Fig. 8-3

## 8.4 TAB ADJUSTMENT

### **MACHINE CONDITION:**

The upper mechanical assembly must be raised.

### **OBJECTIVE ADJUSTMENT:**

Tab (1) must come into contact with print bar (2), and simultaneously the balancer (3) must come into contact with the tab support shaft (4).

### **PROCEDURE:**

Loosen screw (5) and position the parts as explained. Tighten the screw. When adjustment is complete, make sure that the following conditions are met when clearing the gap between the balancer and knob: the tab must be in contact on the entire paper path or at a maximum distance of 0.5 mm from the platen.

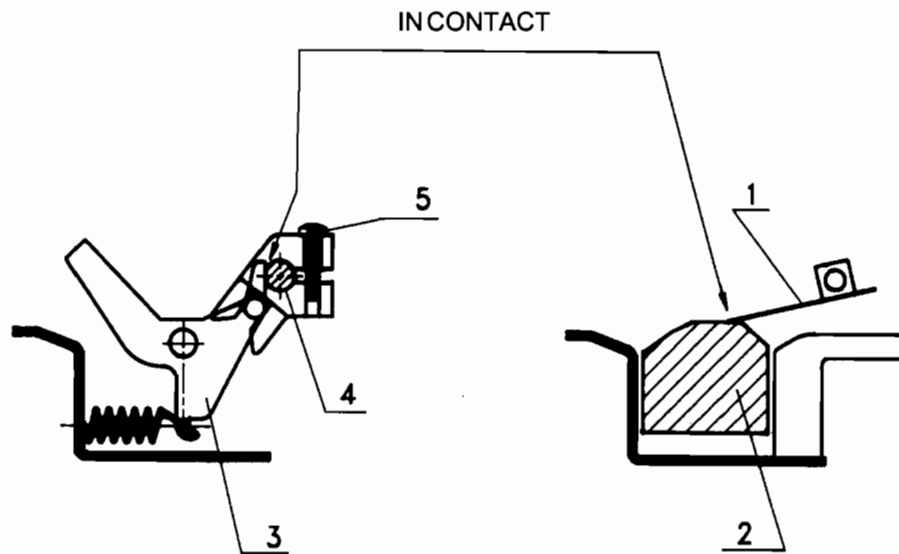


Fig. 8-4

**Note:** Perform this procedure after adjusting the print bar.

## 8.5 FRONT TAB OPENING CHECK

### **MACHINE CONDITION:**

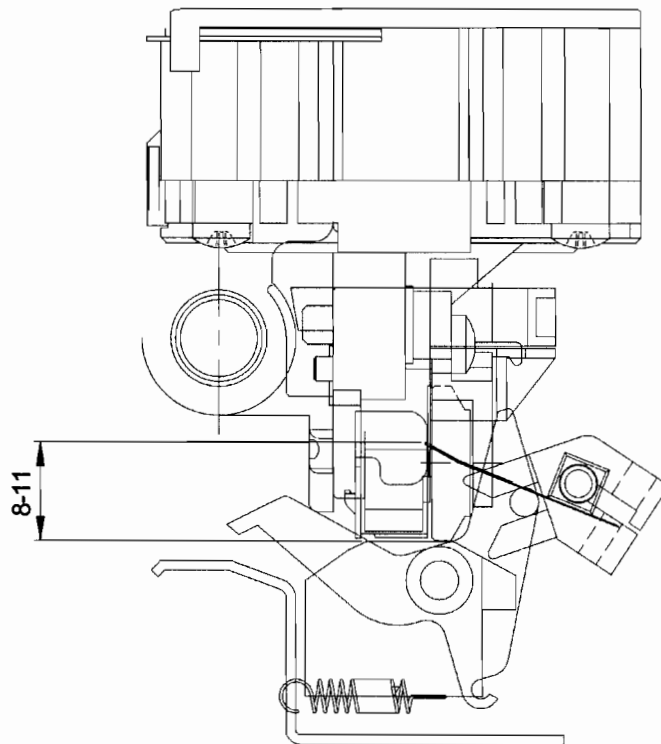
Rear frame assy closed and carriage moved completely to the right.

### **OBJECTIVE ADJUSTMENT:**

Distance between the front tab and print bar.

### **PROCEDURE:**

After making sure that the tab is adjusted correctly (as indicated in the previous section), close the rear frame assy and then move the carriage to the right. Using a probe, check that the point of the tab is located at a distance between 8 and 11 mm from the print bar, measuring at 5-6 cm. from the left edge of the print carriage.



*Fig. 8-5*

## 8.6 ROLLER GEAR ADJUSTMENT

### **MACHINE CONDITION:**

Upper mechanical assembly closed.

### **OBJECTIVE ADJUSTMENT:**

Mesh between cogged wheels (1) and (2) with a maximum radial clearance of 0.2 mm between the teeth. Check this clearance throughout the entire wheel rotation. Adjust the two matings on the right-hand side of the printer.

### **PROCEDURE:**

Turn screws (3) that secure the bushing, tightening them with a torque equivalent to  $6 \pm 0.5$  Kgcm.

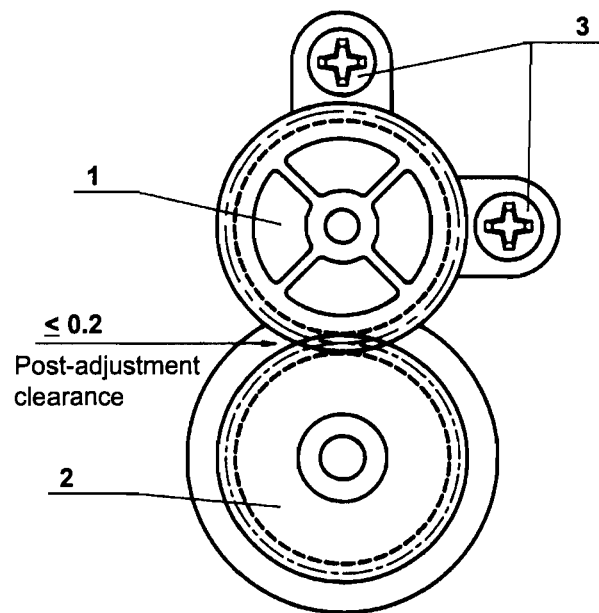


Fig. 8-6

**Note:** Perform this adjustment on both gear pairs on the printer.

## 8.7 FRONT PRESSURE ROLLER ADJUSTMENT

### **MACHINE CONDITION:**

Service cam with its minimum throw area facing the probe roller.

### **OBJECTIVE ADJUSTMENT:**

Make sure that there is a small clearance between the probe roller (7) and the service cam (6).  
(To check the correctness of the adjustment remove the probe and, without changing the phase, check for a slight clearance between the roller and cam without loading the springs. There must be no clearance when the probe is inserted again).

### **PROCEDURE:**

Insert an 0.5 mm thick probe (1) between the pressure rollers (5) and the feed rollers (8); by acting on shaft (2), position the three levers (3) so that they come into contact with the springs and then tighten screws (4) with a torque of 20 Kgcm while holding the roller against the cam's smallest radius.

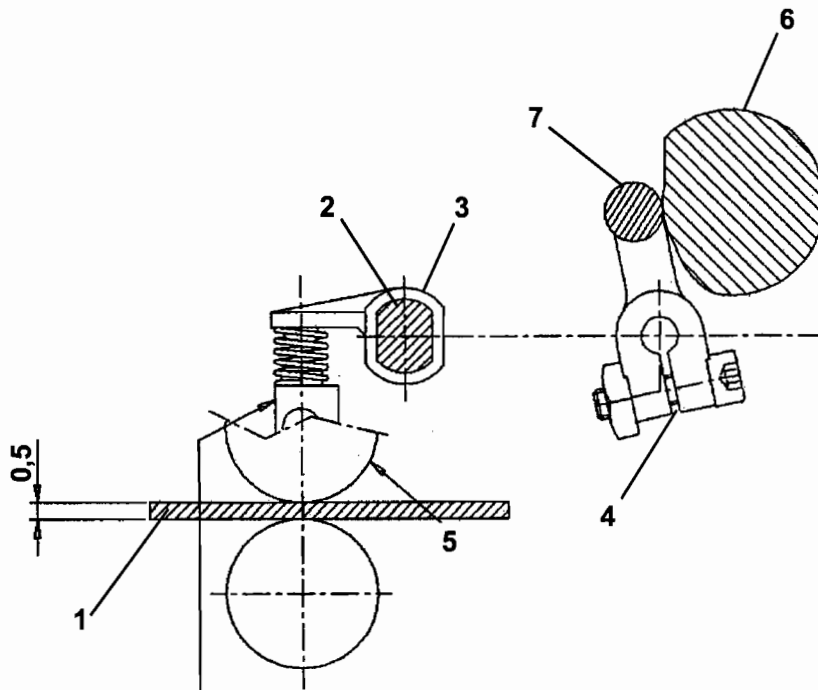


Fig. 8-7

**Note:** The adjustment value can vary for certain non-standard products.

## 8.8 TAB OPENING ADJUSTMENT

### **MACHINE CONDITION:**

With the upper mechanical assembly in its working position and with the printhead carriage against the left side, position and secure lever (1) on the shaft with a clearance of 1.5 mm between the knob and balancer (with respect to the profile of the carriage).

Upper mechanical assembly lifted and lever (1) against the lifting lever control pin (2).

### **OBJECTIVE ADJUSTMENT:**

A distance of between 5 and 8 mm between the edge of the tab (3) and the center of the print bar.

### **PROCEDURE:**

Turn screw (4) that secures lever (1) on the tab shaft.

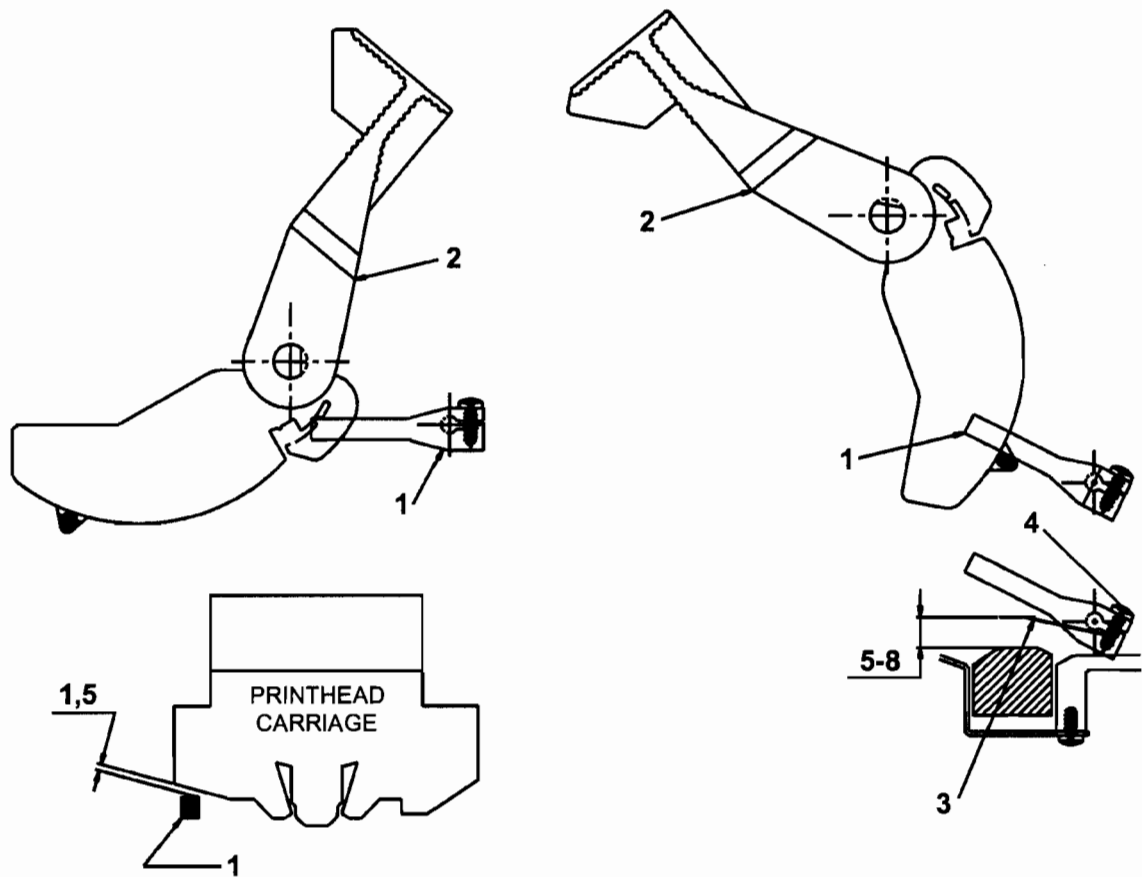


Fig. 8-8

**Note:** This adjustment must be performed after the platen and tab adjustments.

## 8.9 HORIZONTAL MAGNETIC DEVICE/MICR OPTION CARRIAGE FEED BELT TENSION ADJUSTMENT

### **MACHINE CONDITION:**

Read/write carriage in its reset position (end-of-stroke at the motor side).

### **OBJECTIVE ADJUSTMENT:**

The tension of timing belt (1) so that a 5 mm sag is obtained when a force of 60 gr. is applied at the center of the carriage. Measure with the carriage in its reset position (left-hand end-of-stroke - motor end).

### **PROCEDURE:**

Loosen the securing screws and then move motor (2) until the objective adjustment is reached; tighten the screws again.

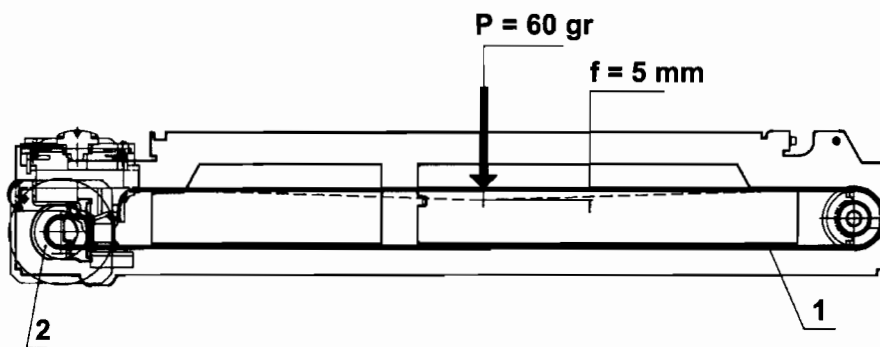


Fig. 8-9



## 8.10 HORIZONTAL MAGNETIC DEVICE/MICR DOOR ADJUSTMENT

### **MACHINE CONDITION:**

Read/write carriage at its reset position (end-of-stroke at motor side) and semi-tie rod joining screw (1) loose.

### **OBJECTIVE ADJUSTMENT:**

Coplanarity between the door and the front surface of the frame.

### **PROCEDURE:**

Fit the door (2) against the slot (3), working in the area between the leaf spring and the semi-tie rod tooth (4); tighten the screw.

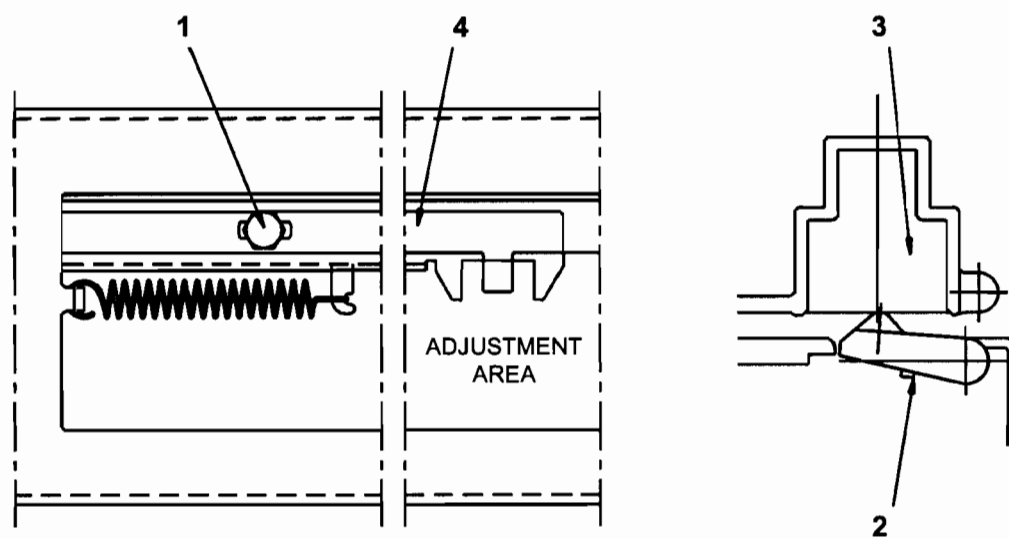


Fig. 8-10

## 8.11 HORIZONTAL MAGNETIC DEVICE/MICR PRESS POSITIONING

### **MACHINE CONDITION:**

Cam crank (4) against the shortest cam radius.

Position press (1) inside conveyor (2) with an indent of 0.5-1 mm and then phase cam (3) so as to move cam crank (4) against its shortest radius. Secure the cam crank on the shaft with its screw (5). Make sure that the press is indented throughout the entire paper path).

### **OBJECTIVE ADJUSTMENT:**

Press in into working position.

### **PROCEDURE:**

Rotate the cam until the cam crank (4) moves against its maximum radius; then, with the press resting on the paper feed surface, check for a clearance in the joint at point "A".

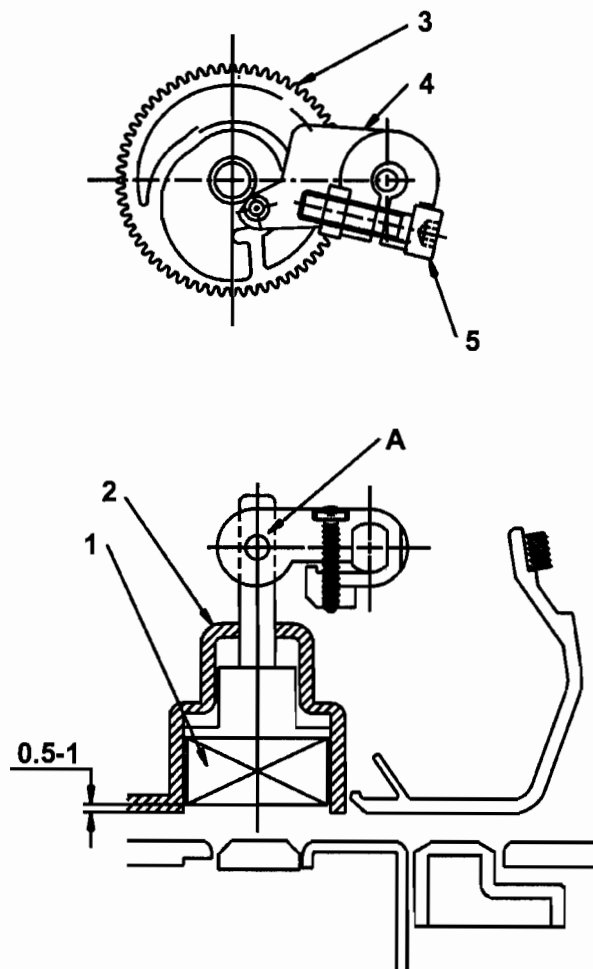


Fig. 8-11

## 8.12 POSITIONING THE ASSEMBLY ON THE HORIZONTAL MAGNETIC DEVICE/ MICR

### **MACHINE CONDITION:**

Unimportant.

### **OBJECTIVE ADJUSTMENT:**

Coplanarity between the magnetic device door and the slot paper conveyor.

### **PROCEDURE:**

Hook slots (1) on the sides of the magnetic device frame onto pins (2) on the sides of the machine. Insert the securing screws (3).

Push the magnetic device frame upward until it rests against the paper conveyor on both right- and left-hand sides.

Tighten the screws with a torque of 8 Kgcm.

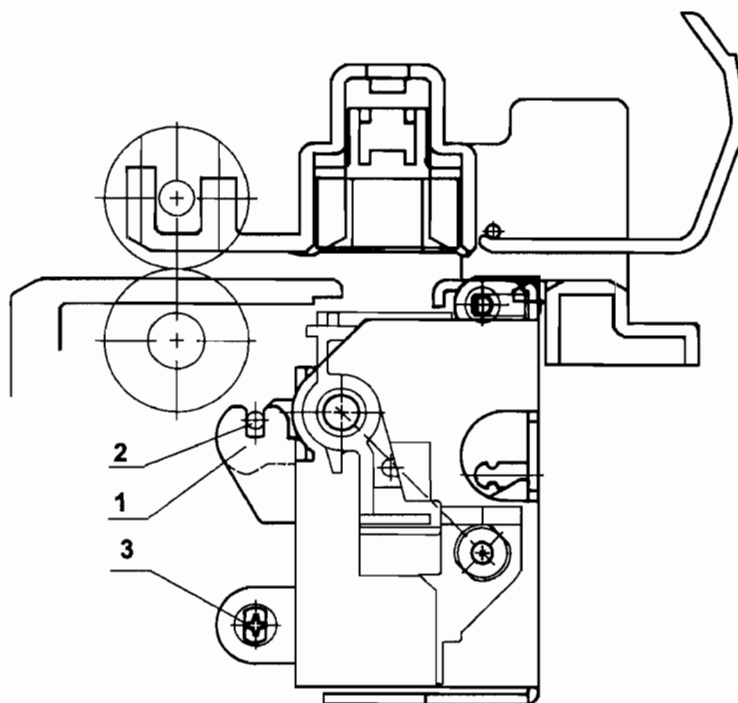


Fig. 8-12



## 9. DISASSEMBLY/REASSEMBLY PROCEDURES

For easier consultation, the disassembly procedures have been divided as follows:

- **9.2.X** disassembly of the basic machine, with no option installed
- **9.3.X** disassembly of the basic machine's horizontal magnetic device /MICR

Each individual disassembly procedure is described in the following way:

- **Wherever possible, reference is made to previous disassembly procedures**, so as to give a backward glance at the disassembly that comes prior to the one described.
- **Operation steps** described in sequence.
- **Notes:** recall adjustments that need to be made after reassembly, precautions or warnings to be observed.

## **9.1 GENERAL DISASSEMBLY/REASSEMBLY PRECAUTIONS**

- **To ensure maximum safety, before starting any disassembly operation power off the printer and unplug its power cord from the electrical outlet.**
- **All operations should be performed in a clean and uncluttered area.**
- **Follow the procedures carefully; do not unscrew parts that are not to be disassembled.**
- **Store the disassembled parts in a clean place where there is no danger of them getting lost.**
- **After replacing the parts, make sure that they have not been deformed during assembly; restore the correct conditions if necessary.**
- **Reassembly must be performed by following the disassembly procedures in reverse order.**
- **Before disconnecting the cables make sure to take note of their connections for reassembly.**
- **After servicing, lubricate where specified.**
- **When replacing the main board, update the firmware to the latest release (section 1.9.1), run the installation set-up (Chapter 4) and then perform the electromechanical adjustments from the console (Chapter 4).**
- **When replacing the power supply assembly, make sure that the line voltage rating of the replacement module corresponds to the value indicated on the printer's electrical data plate.**
- **At the end of the service call, run an overall check on the printer to make sure that all failures are corrected.**

## 9.2 DISASSEMBLY/REASSEMBLY OF THE BASIC MACHINE

### 9.2.1 CASE DISASSEMBLY/REASSEMBLY

- Open the printer's top cover.
- Remove the two securing screws (1) from the front of the case (2). Remove this front part of the case from the machine by pulling it in the direction of the arrows in the figure below.
- Using a flat-blade screwdriver, release the case's two front snap features (3).
- Insert a pointed object in the holes at the rear right and left sides of the case and then release the two rear snap features (4); partly lift the case off the base.
- Release the console from the case by pressing gently in the points indicated by the arrows in the figure below and lifting it upward.
- Pass the console through the flat cable passage slot and remove the case from the machine.

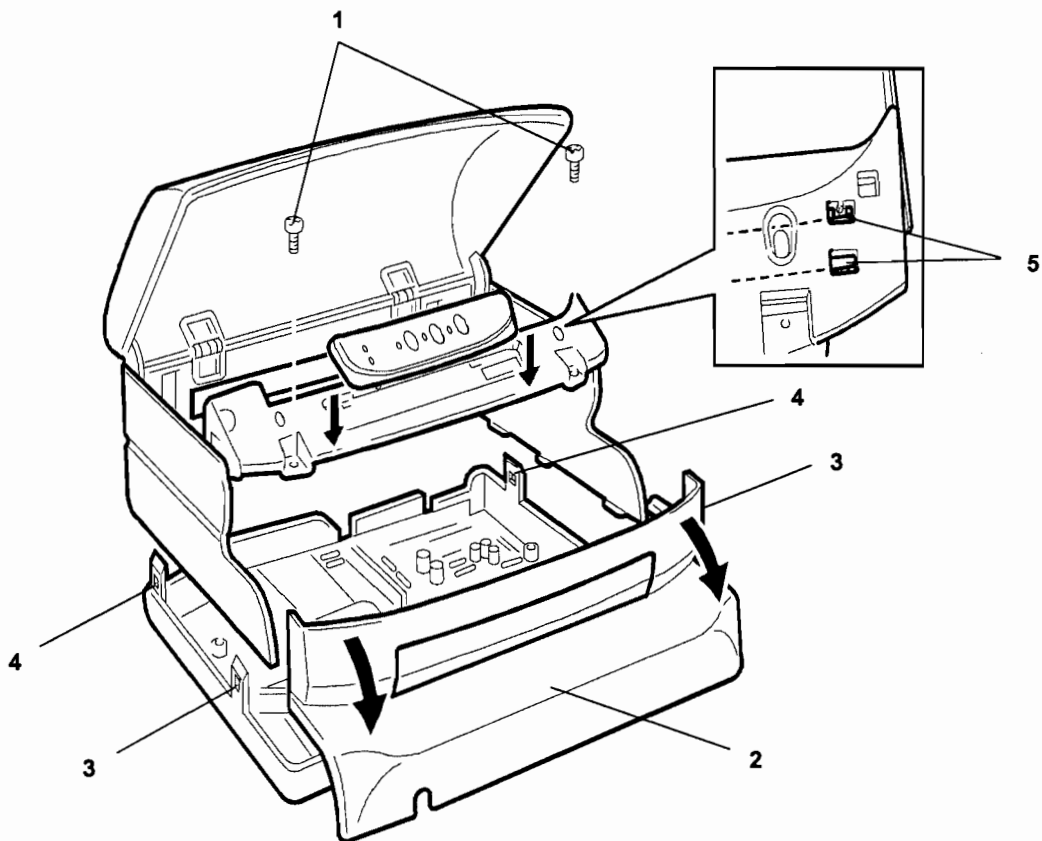


Fig. 9-1

**Note:** During the reassembly of the case, secure the console flat cable with the guide tabs (5) located at the rear of the console panel.

## 9.2.2 CONSOLE DISASSEMBLY/REASSEMBLY

- Remove the printer case (section 9.2.1).
- Loosen screws (1) and turn sideways the securing plates of the mechanical assembly rubber stops so as to release the front of the mechanical assembly from their slots.
- Lift the front part of the mechanical assembly off the base of the printer, partly rotating it until you are able to reach console connector (2) on the main board.
- Remove the board's protection.
- Remove the console by unplugging its flat cable connector from the main board (2) and then releasing the flat cable from its securing tabs (3) on the base.

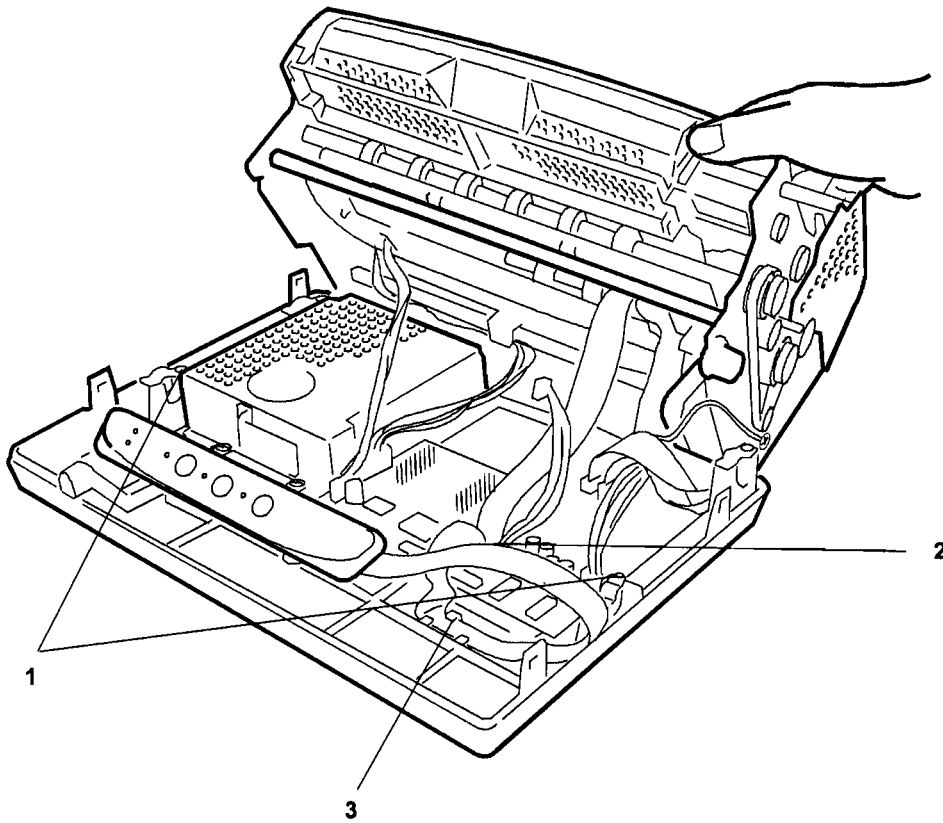


Fig. 9-2



### 9.2.3 MECHANICAL ASSEMBLY DISASSEMBLY/REASSEMBLY

- Remove the printer case (section 9.2.1) and console (section 9.2.2).
- Lift the front part of the mechanical assembly off the base of the printer, partly rotating it until you are able to reach the connectors on the main board.
- Unplug all the cables connecting the mechanical assembly to the main board, with the exception of the main board-to-power supply unit connection cable.
- Loosen screws (1) of the plates that secure the assembly's rear rubber stoppers so that the entire mechanical assembly is released.
- Remove screw (2) that secures the ground wires.
- Lift the entire mechanical assembly from the base of the printer.

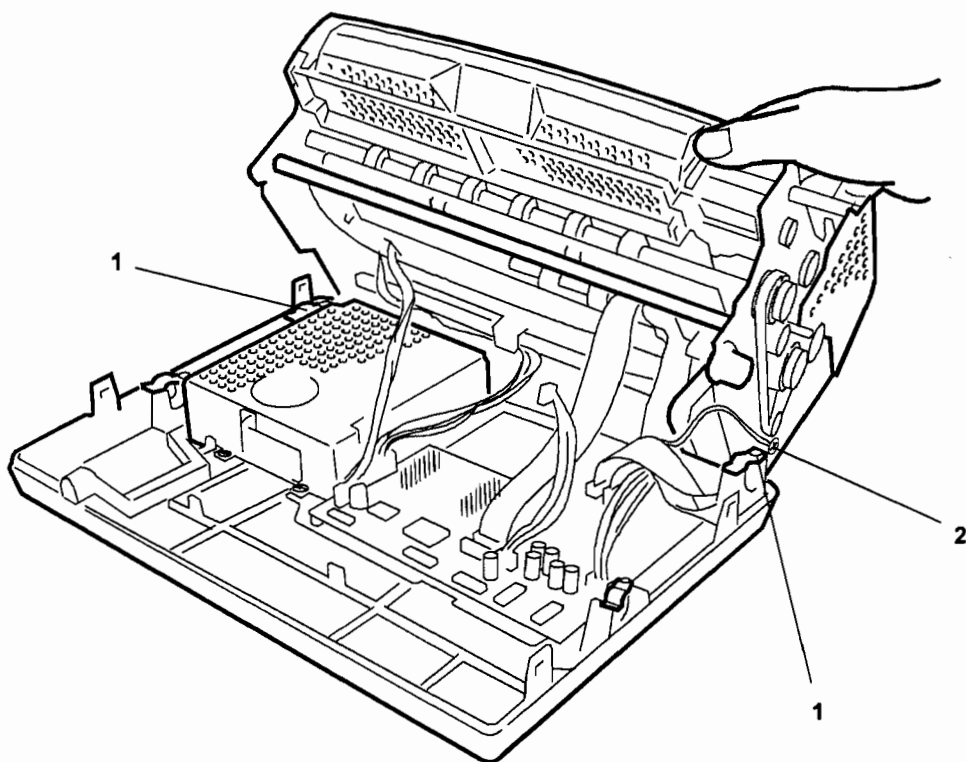


Fig. 9-3

### 9.2.4 PRINthead FLAT CABLE DISASSEMBLY/REASSEMBLY

- Remove the printer case (section 9.2.1).
- Free the cable clip (1) located on the right-hand side of the frame by unhooking it from the inside (2) of the frame itself.
- Remove the soundproofing (3).
- Loosen screw (4) that secures the rear cable fastener, rotate the fastener and then free the flat cables.
- Rotate the flat cable support (5) connected to the printhead upwards as far as it goes.
- Remove the mylar sheet (6) from underneath the flat cable support, then free the flat cables from their securing tabs on the support.

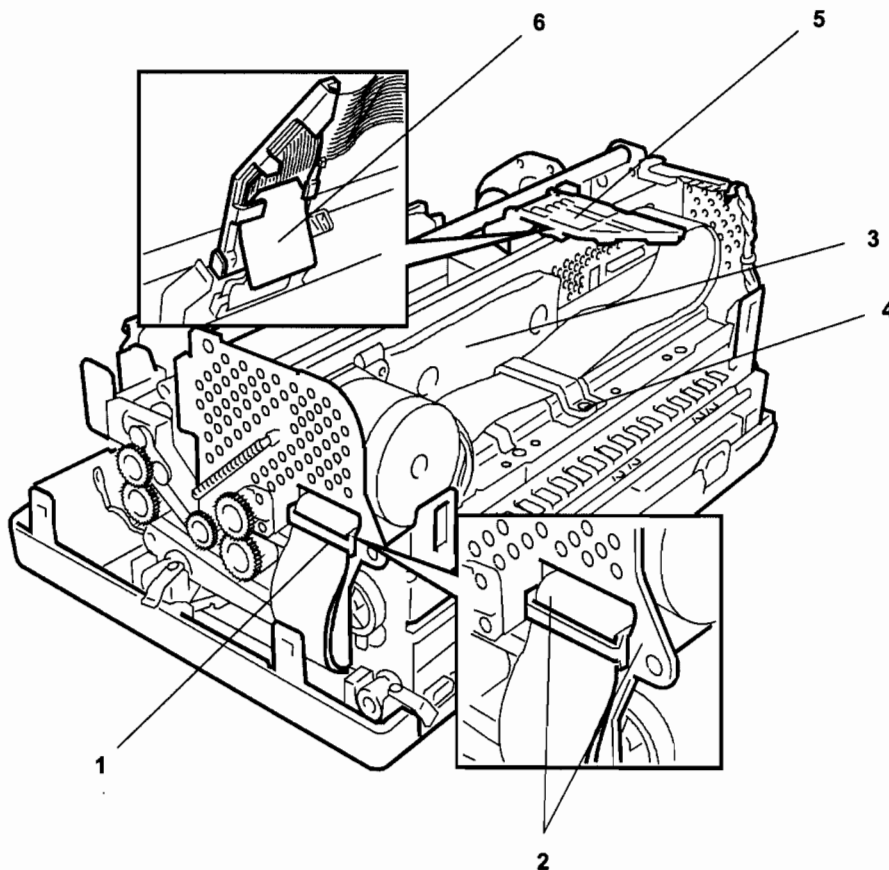


Fig. 9-4

- Remove the printhead by unscrewing the two screws (7).
- Unplug the two flat cables from their connectors (8) on the printhead.

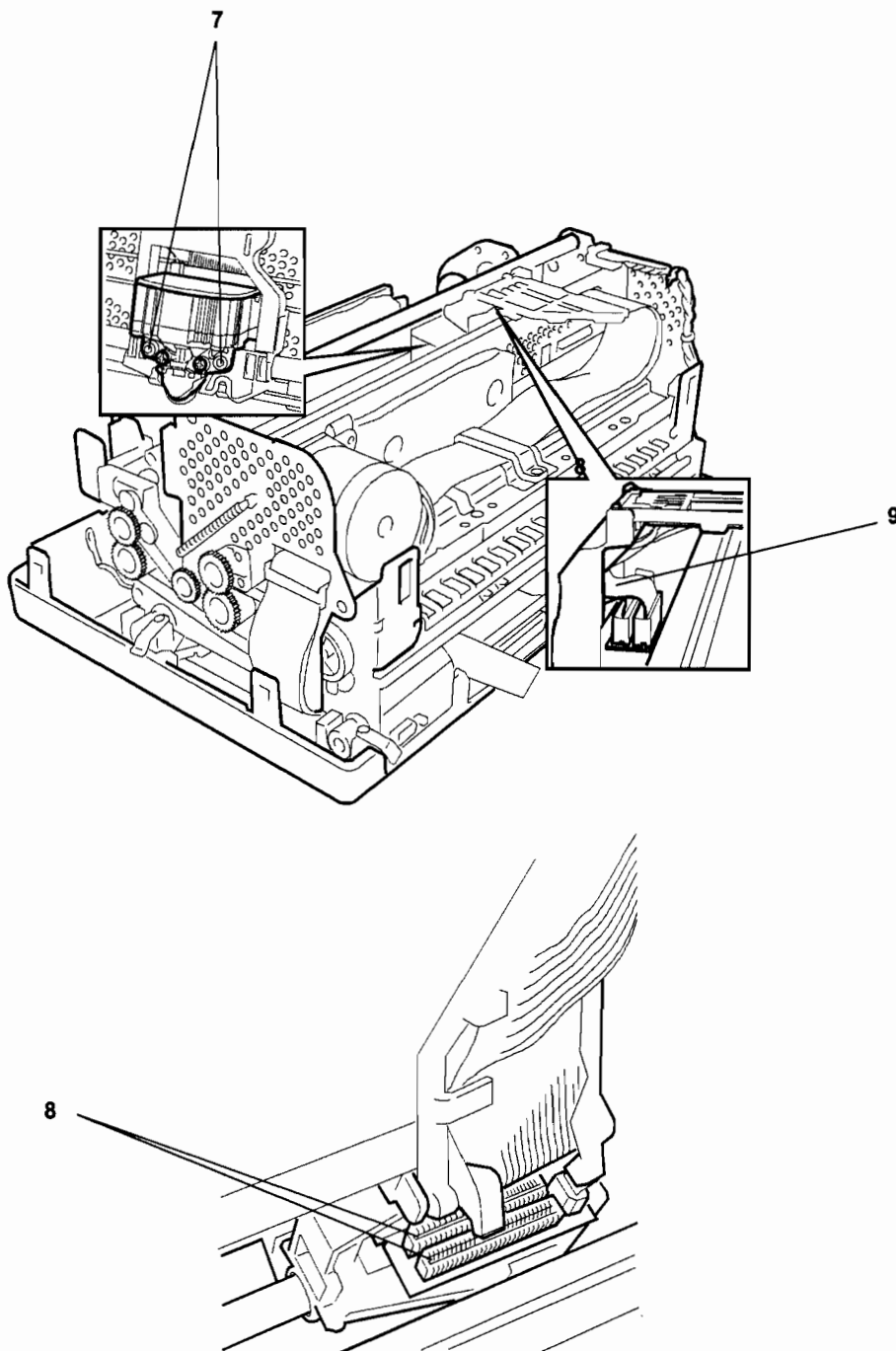


Fig. 9-5

**Warning:** When reconnecting the flat cables to the printhead, make sure to restore the correct cable route (9) as indicated in the figure so that the cables do not interfere with the ribbon rewind gears; if the correct route is not restored the cables could become seriously damaged during machine operation.

### 9.2.5 PRINthead DISASSEMBLY/REASSEMBLY

- Open the printer cover and lift the mechanical assembly.
- Remove the ribbon cartridge.
- Unscrew the two screws (1) that secure the printhead.
- Partly slide off the printhead from the carriage and unplug the two flat cables (2) from the connectors on the printhead.

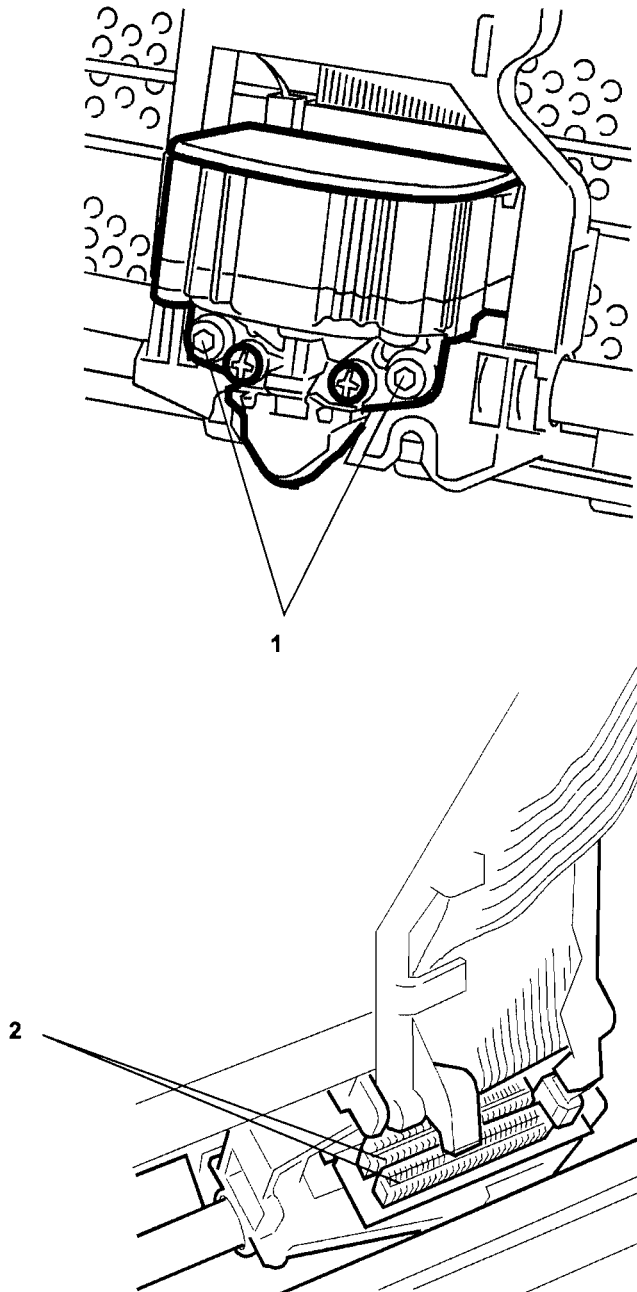


Fig. 9-6

**Note:** After printhead reassembly, calibrate the printhead photosensor.

## 9.2.6 PRINthead PHOTOSENSOR DISASSEMBLY/REASSEMBLY

- Remove the printhead (section 9.2.5).
- Remove screw (1) that secures the printhead photosensor and remove the photosensor from its seat.
- Unplug the photosensor flat cable from its connector (2) on the printhead.
- Replace the old photosensor with the new one, making sure that it rests against support shield (3);; replace and tighten the securing screw (1).

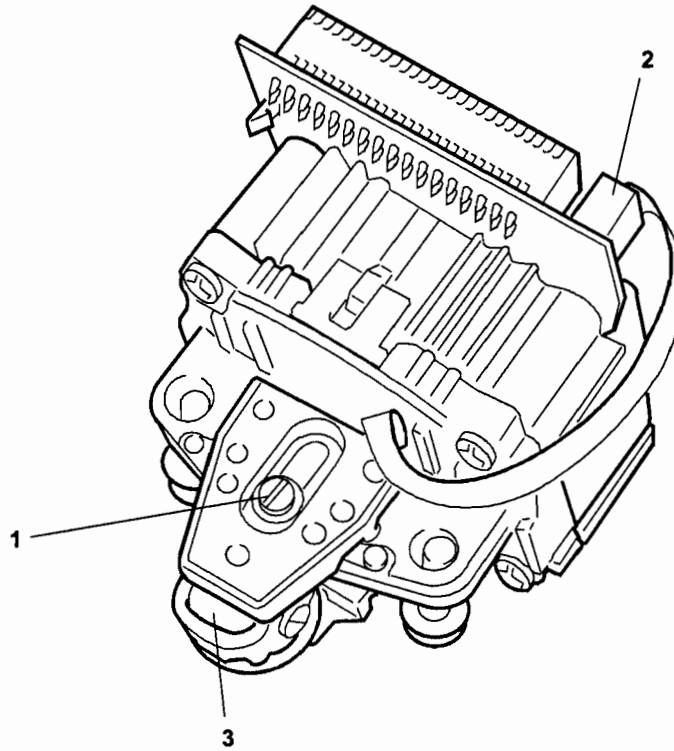
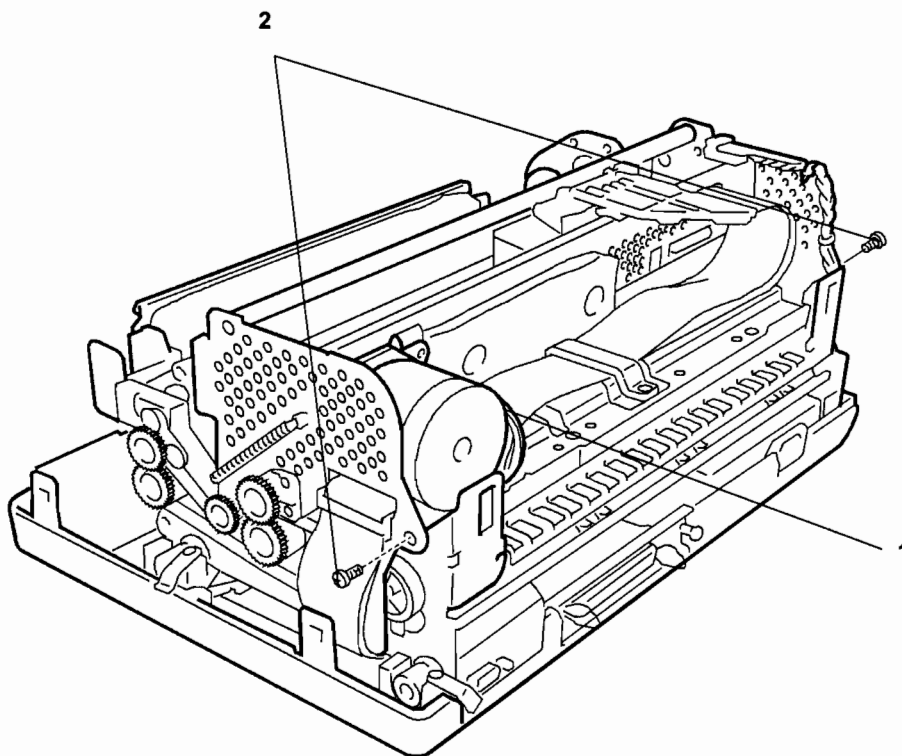


Fig. 9-7

**Note:** The printhead photosensor must be calibrated whenever the printhead is replaced.

### 9.2.7 UPPER PART OF THE MECHANICAL ASSEMBLY DISASSEMBLY/REASSEMBLY

- Remove the printer case (section 9.2.1) and console (section 9.2.2).
- Lift the front part of the mechanical assembly off the base of the printer, partly rotating it until you are able to reach the connectors on the main board.
- Unplug the printhead and carriage reset photosensor cables from the main board. Free the carriage reset photosensor wires from its plastic retainers.
- Unplug connector (1) from the carriage transport motor.
- Raise the upper part of the mechanical assembly using the specific lever.
- Remove the two rear side screws (2) so as to detach the upper part of the mechanical assembly.



*Fig. 9-8*

**Note:** During reassembly, make sure to route the cables through the appropriate slots and check the adjustment of the roller gears (section 8.1.7).

## 9.2.8 PAPER FEED MOTOR DISASSEMBLY/REASSEMBLY

- Remove the mechanical assembly (section 9.2.3)
- Loosen the two nuts (1) that secure the motor and then release the document feed belt.
- Remove the nuts and extract the motor.

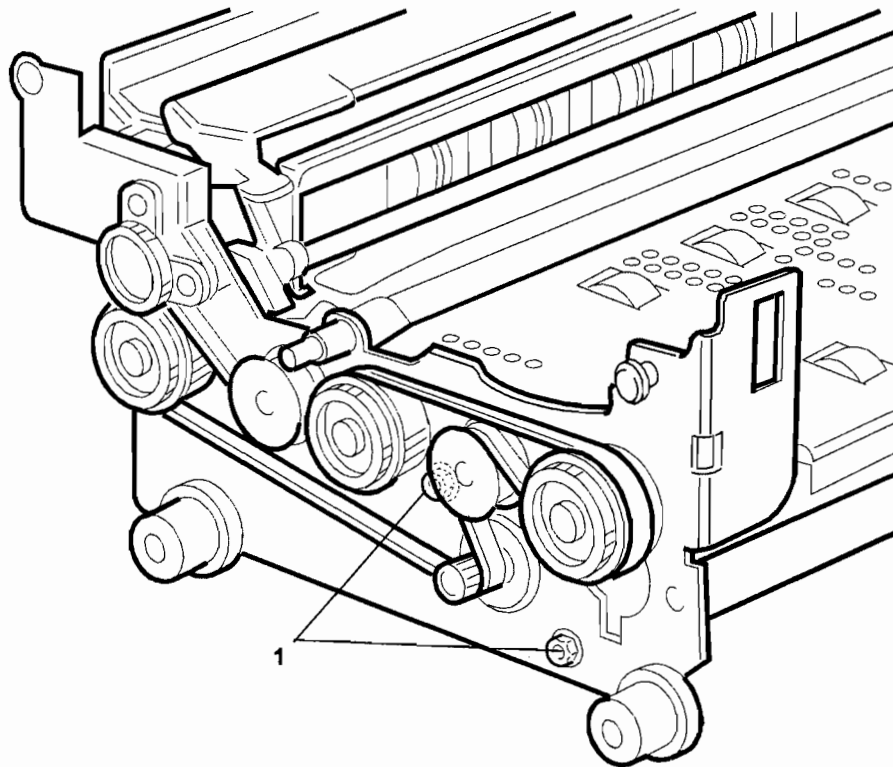


Fig. 9-9

**Note:** After reassembly, adjust the tension of the document feed belt (section 8.6).

### 9.2.9 PRINTHEAD MOVEMENT MOTOR DISASSEMBLY/REASSEMBLY

- Remove the upper part of the mechanical assembly (section 9.2.7).
- Loosen the screw (1) that secures the return pulley support slide and then release the carriage movement belt from the motor pinion.
- Release the printhead flat cable by loosening screw (2) and then unscrew the three special securing screws (3) and then remove the printhead movement motor being careful to avoid damaging the ribbon feed gears.

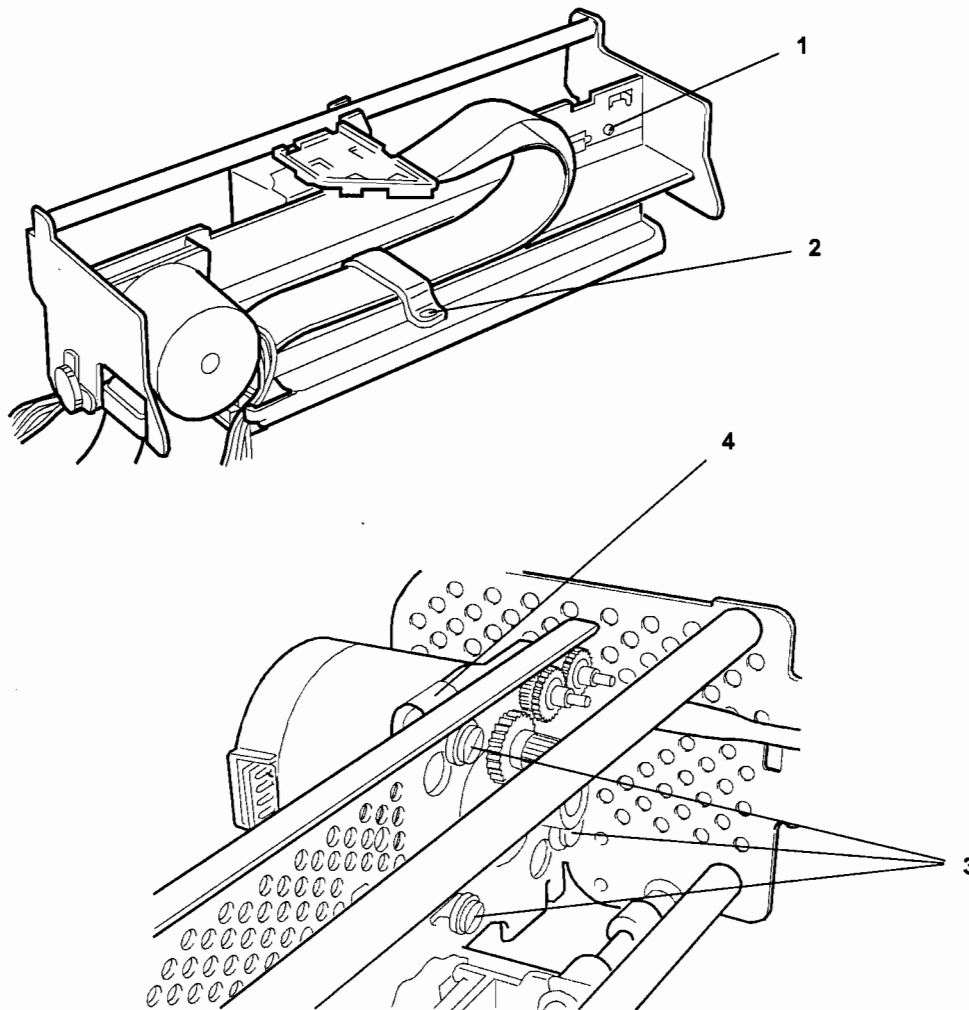


Fig. 9-10

**Note:** After reassembly, correctly reposition ground spring (4) and then adjust the carriage feed belt (section 8.9).



### 9.2.10 CARRIAGE RESET PHOTOSENSOR DISASSEMBLY/REASSEMBLY

- Remove the printer case (section 9.2.1) and console (section 9.2.2).
- Lift the front part of the mechanical assembly off the base of the printer, partly rotating it until you are able to reach the connectors on the main board.
- Unplug the carriage reset photosensor cable from the main board and then release it from its plastic retaining clips.
- Cut the cable clips (1) and remove the photosensor by unscrewing screw (2).

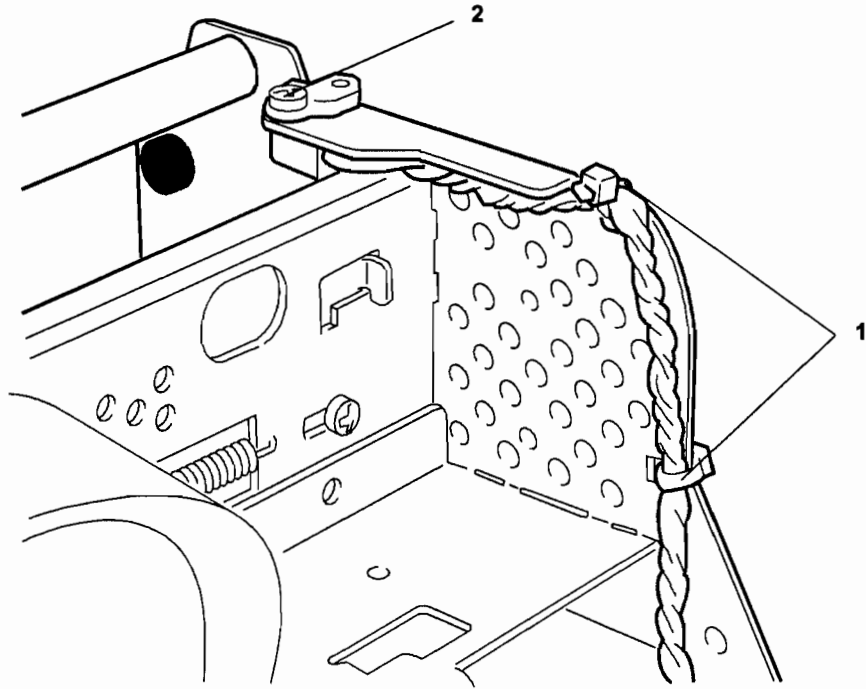


Fig. 9-11

**Note:** During reassembly, replace the cable clips.

### 9.2.11 ROLLER SUPPORT TRAY DISASSEMBLY/REASSEMBLY

- Remove the printer case (section 9.2.1) and console (section 9.2.2).
- Remove the mechanical assembly, separating it from the base of the machine (section 9.2.3).
- Free the carriage reset photosensor wires from their plastic retaining clips (1).

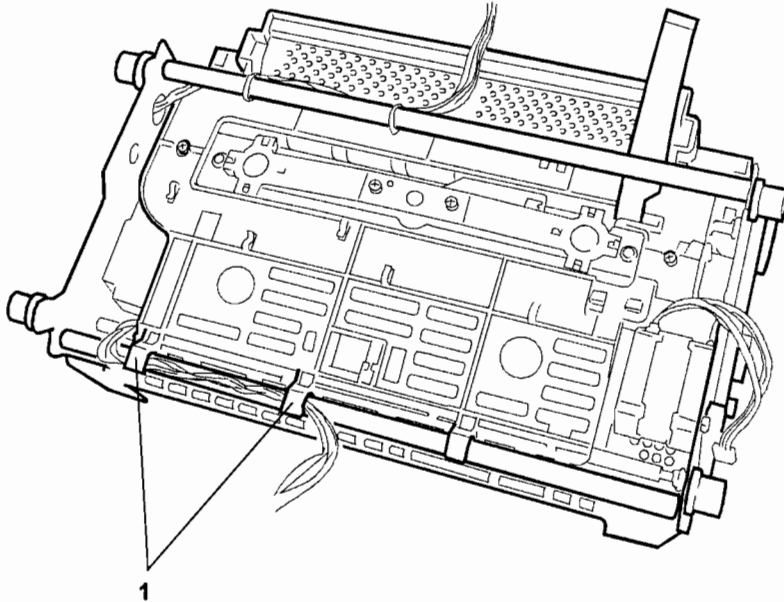


Fig. 9-12

- Remove the upper part of the mechanical assembly (section 9.2.7).
- Remove the four screws (2) and then extract the tray, being careful to avoid losing the transmission joint (3) and the tray's soundproofing.

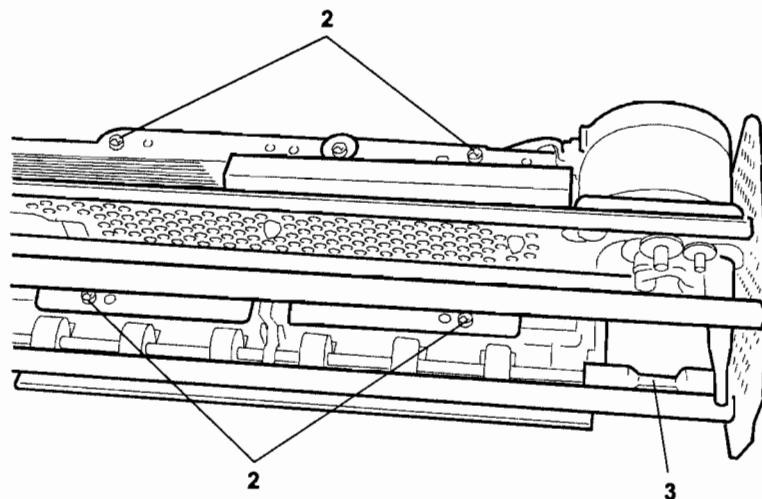
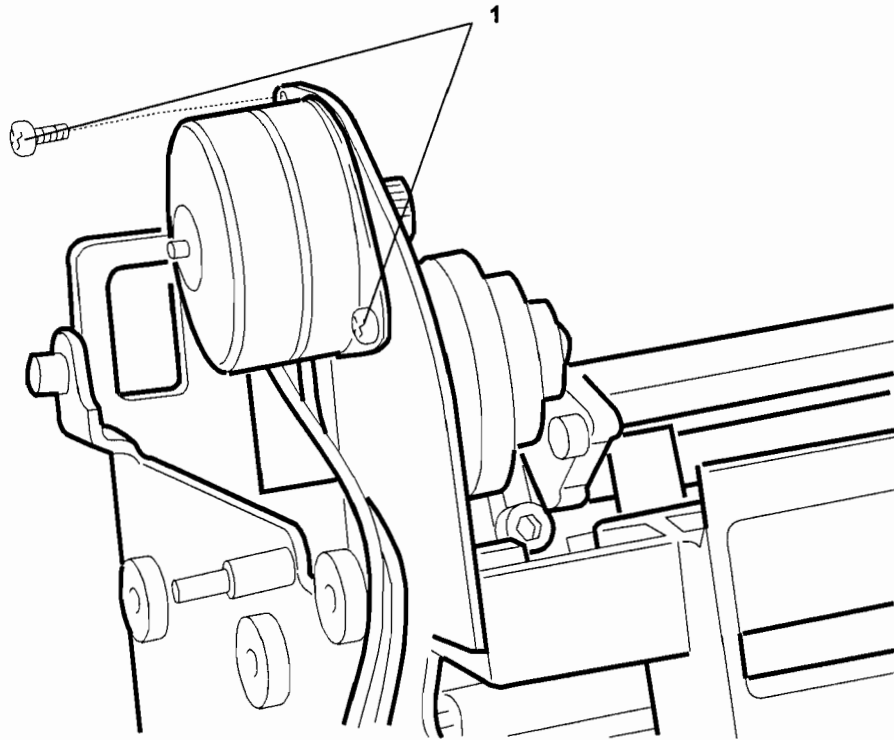


Fig. 9-13

**Note:** During reassembly, make sure to correctly reposition the transmission joint and soundproofing before tightening the screws.

### 9.2.12 SERVICES MOTOR DISASSEMBLY/REASSEMBLY

- Remove the printer case (section 9.2.1)
- Lift the front part of the mechanical assembly off the base of the printer, partly rotating it until you are able to reach the connectors on the main board
- Unplug the services motor connection cable from the main board.
- Remove the two screws (1) that secure the motor to the left-hand side of the frame and remove the motor from the machine.



*Fig. 9-14*

### 9.2.13 FEEDER PHOTOSENSORS DISASSEMBLY/REASSEMBLY

- Remove the mechanical assembly (9.2.3).
- Remove the upper part of the mechanical assembly (9.2.7).
- Remove the roller shield after removing its M3 securing screws (1).

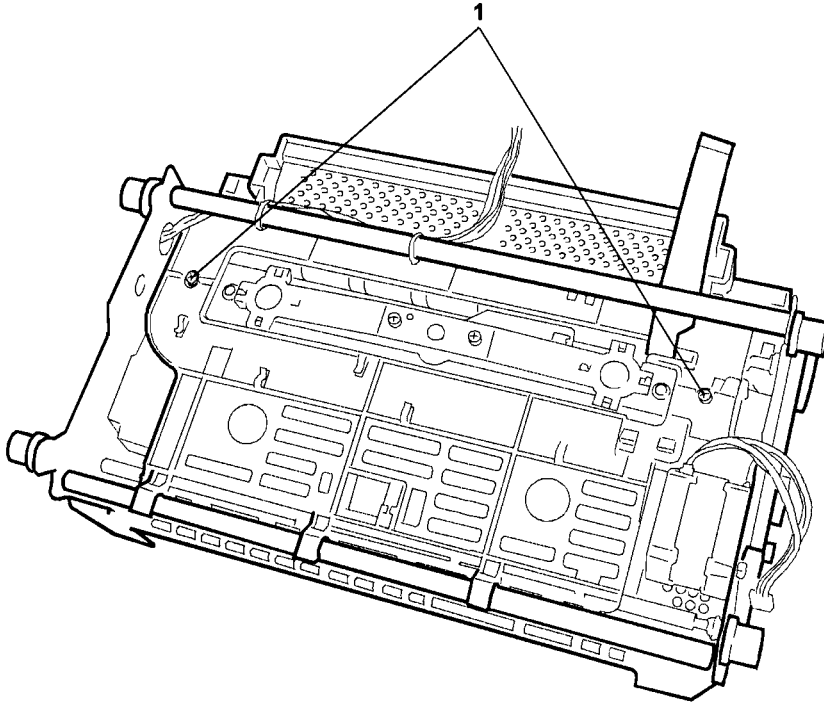


Fig. 9-15

- Unhook the two springs (2), straighten the document stop bar slide-proof fins (3) and then slide the stop bar from its guideways.

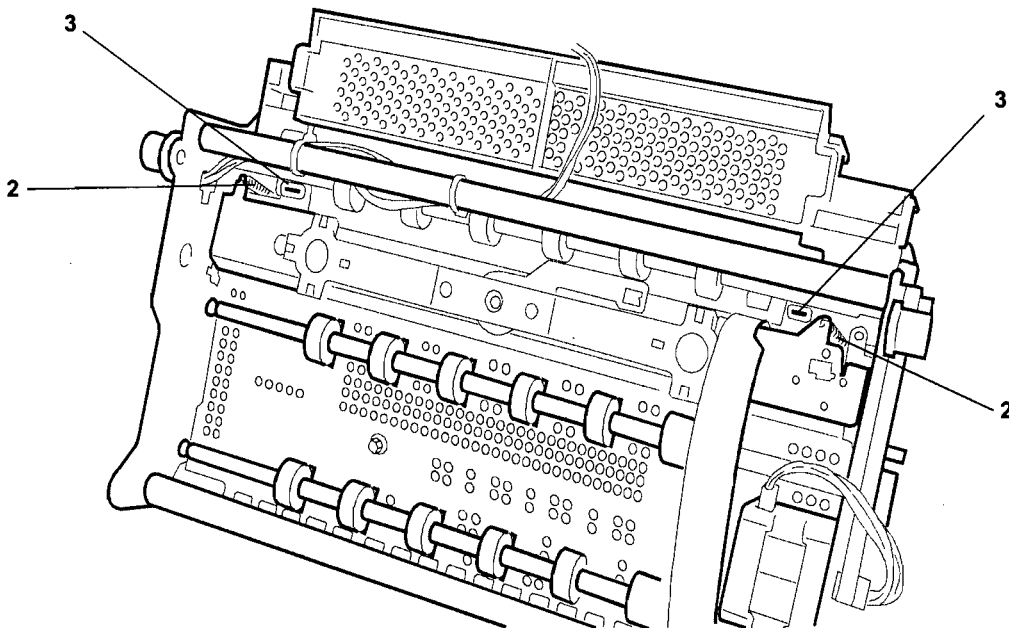


Fig. 9-16

- Remove bushing (4) from alignment pressure roller shaft (5) and then remove the entire assembly (6).

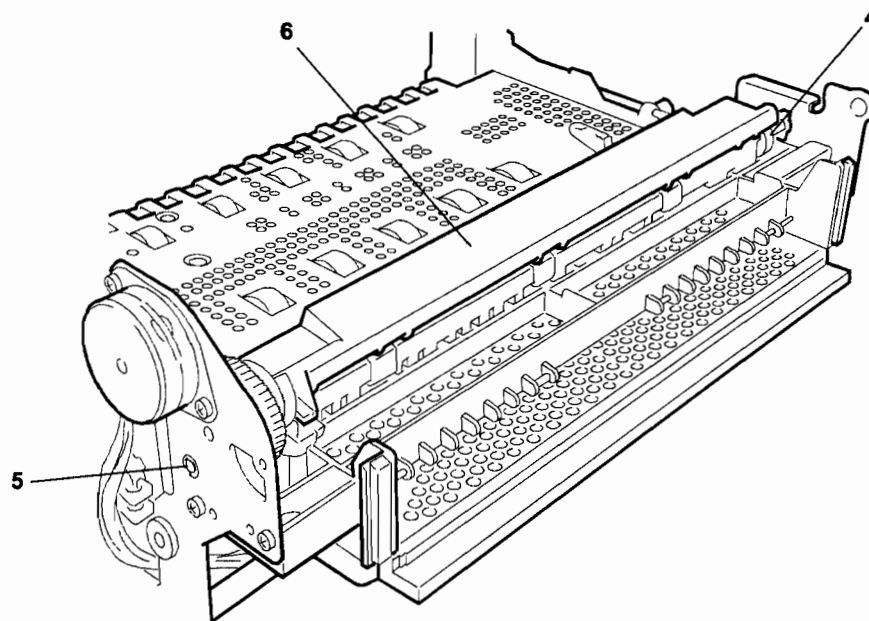


Fig. 9-17

- Remove the six screws (7) that secure the conveyor assembly (8).

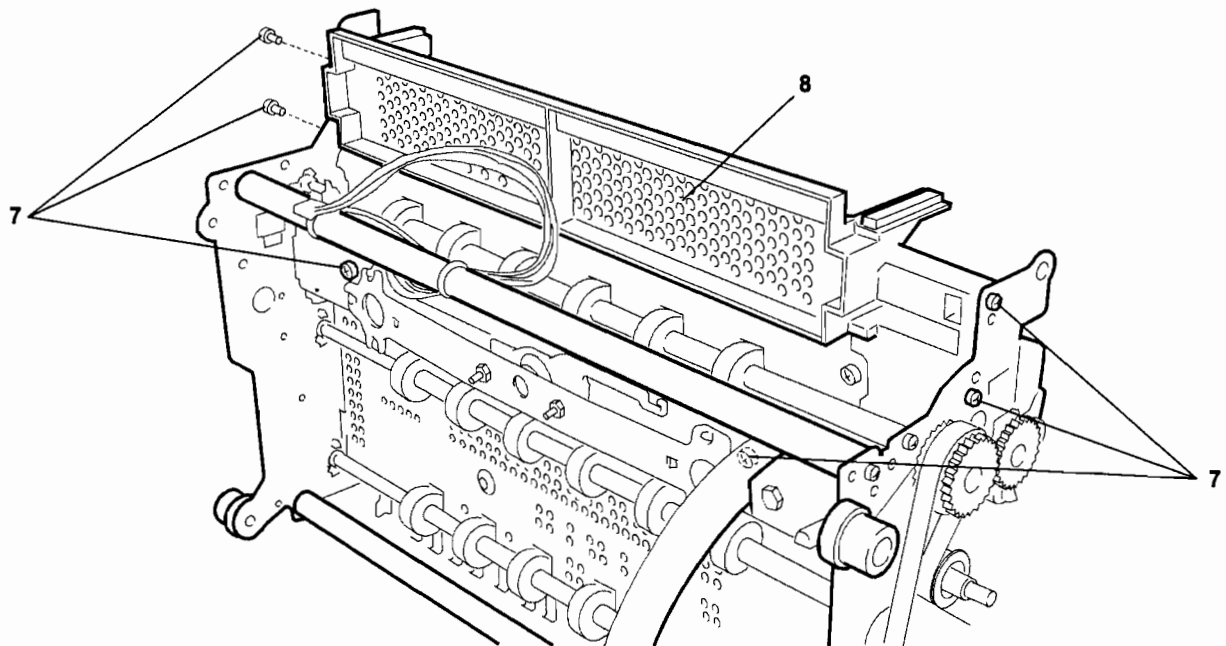


Fig. 9-18

- Remove the two screws (9) that secure photosensor support (10) and then remove the support.

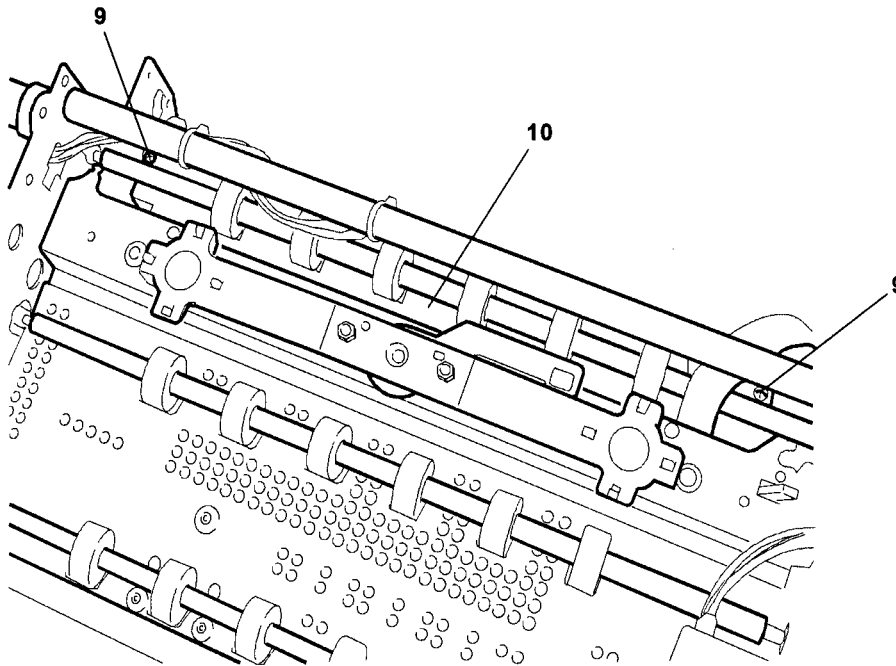


Fig. 9-19

**Note:** When refitting the conveyor assy, make sure that you refit the related bushing before refitting the pressure roller assy.

During reassembly, do not secure the photosensor support until the conveyor assy is properly fitted since the conveyor assy has two reference pins for the photosensor support.

After reassembly, adjust the tab (section 8.4), the front pressure rollers (section 8.7), the opening of the tab (section 8.8) and then calibrate the photosensors (section 4.4.1).

### 9.2.14 PRINT BAR DISASSEMBLY/REASSEMBLY

- Remove the printer case (section 9.2.1)
- Lift the front part of the mechanical assembly off the base of the printer, partly rotating it until you are able to reach the connectors on the main board.
- Unplug all the cables with the exception of the printhead cables.
- Unscrew the two nuts (1) that secure the print bar and then slide it off from the top.

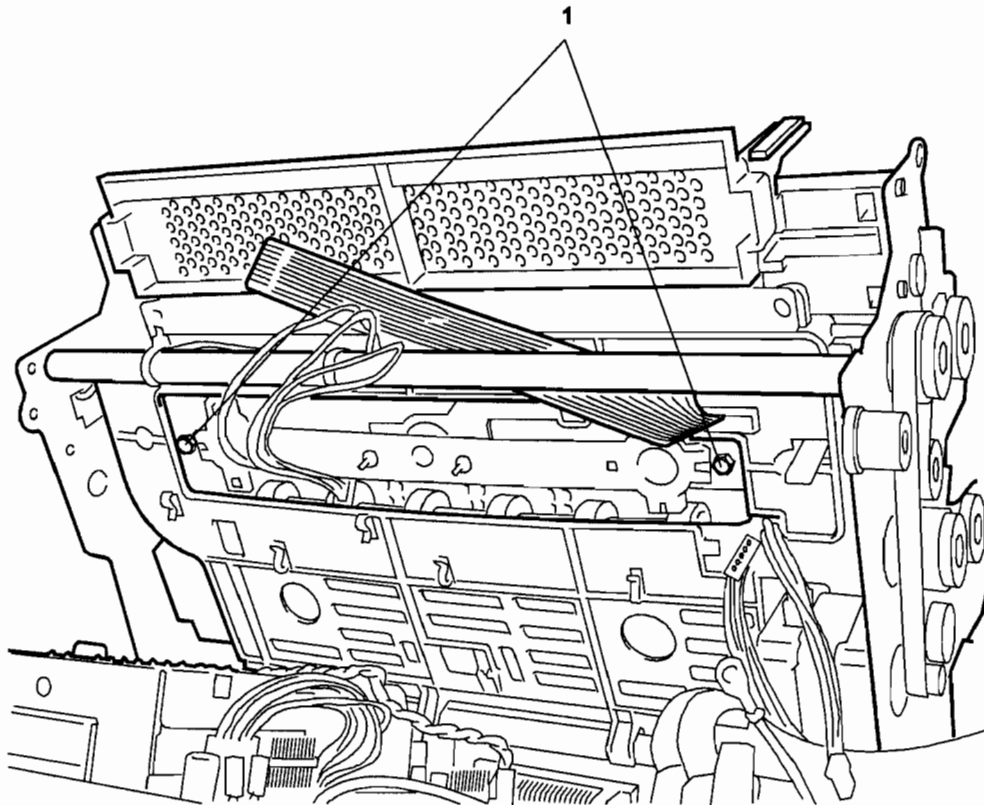


Fig. 9-20

**Note:** After reassembly, adjust the distance between the printhead and print bar (section 8.2).

### 9.2.15 MAIN BOARD DISASSEMBLY/REASSEMBLY

- Power off the machine and unplug the power cord from the electrical outlet.
- Remove the mechanical assembly (section 9.2.3).
- Unplug the power supply cable (1) that connects the main board to the power supply assy.
- Remove the optional interface card (2), if installed.
- Remove the five screws (3) that secure the main board to the base.
- Unscrew the two connection screws (4) of the standard serial port.
- Remove shield (5).
- Extract the main board from the base of the printer.

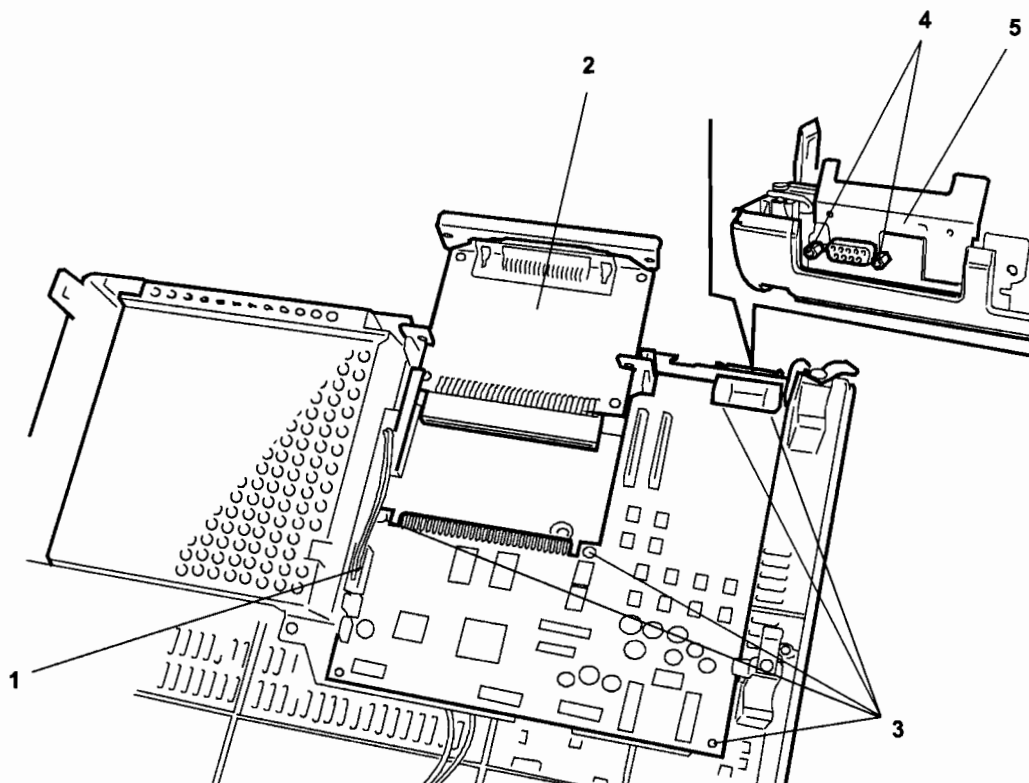


Fig. 9-21

**Nota:** Durante il rimontaggio del lamierino (4), bloccarlo dall'esterno della lamiera di supporto della piastra base.

In caso di sostituzione della piastra, aggiornare il firmware secondo l'ultima release (paragrafo 1.11.1), effettuare il set up di installazione (paragrafo 4.3) e la taratura dei fotosensori (paragrafo 4.4).



## 9.2.16 POWER SUPPLY ASSY DISASSEMBLY/REASSEMBLY

**Note:** If the fuse inside the power supply has blown, replace the entire power supply assy since some components on the power supply board may be damaged.

- Remove the mechanical assy (section 9.2.3)
- Unplug the power supply cable (1) from the main board.
- Unscrews the four screws (2) that secure the power supply and also remove the ground wires.
- Loosen the two screws (3) that secure the switch.
- Extract the power supply assy.

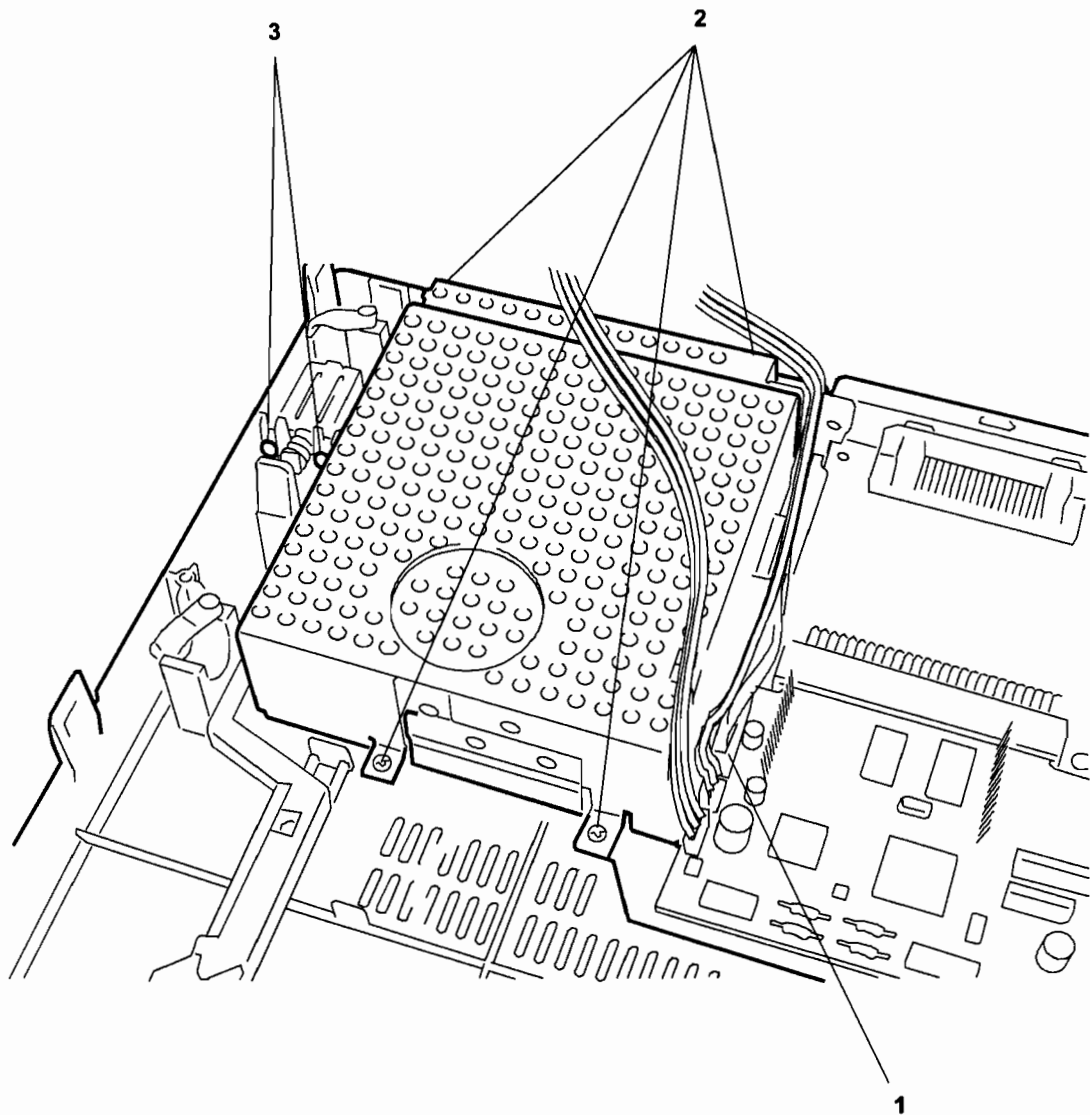


Fig. 9-22

**Note:** During reassembly, make sure that you correctly reposition the ground cables. If you replace the assembly, make sure that the replacement unit uses the correct voltage.

## 9.3 BASIC MACHINE OPTIONS DISASSEMBLY/REASSEMBLY

### 9.3.1 HORIZONTAL MAGNETIC DEVICE/MICR DISASSEMBLY/REASSEMBLY

- Remove the printer case (section 9.2.1).
- Lift the front part of the mechanical assembly off the base of the printer, partly rotating it until you are able to reach the connectors on the main board (1).
- Unplug the cables connected to the magnetic options card.
- Remove the two screws (2) that secure the assembly to the machine frame and then remove this option.

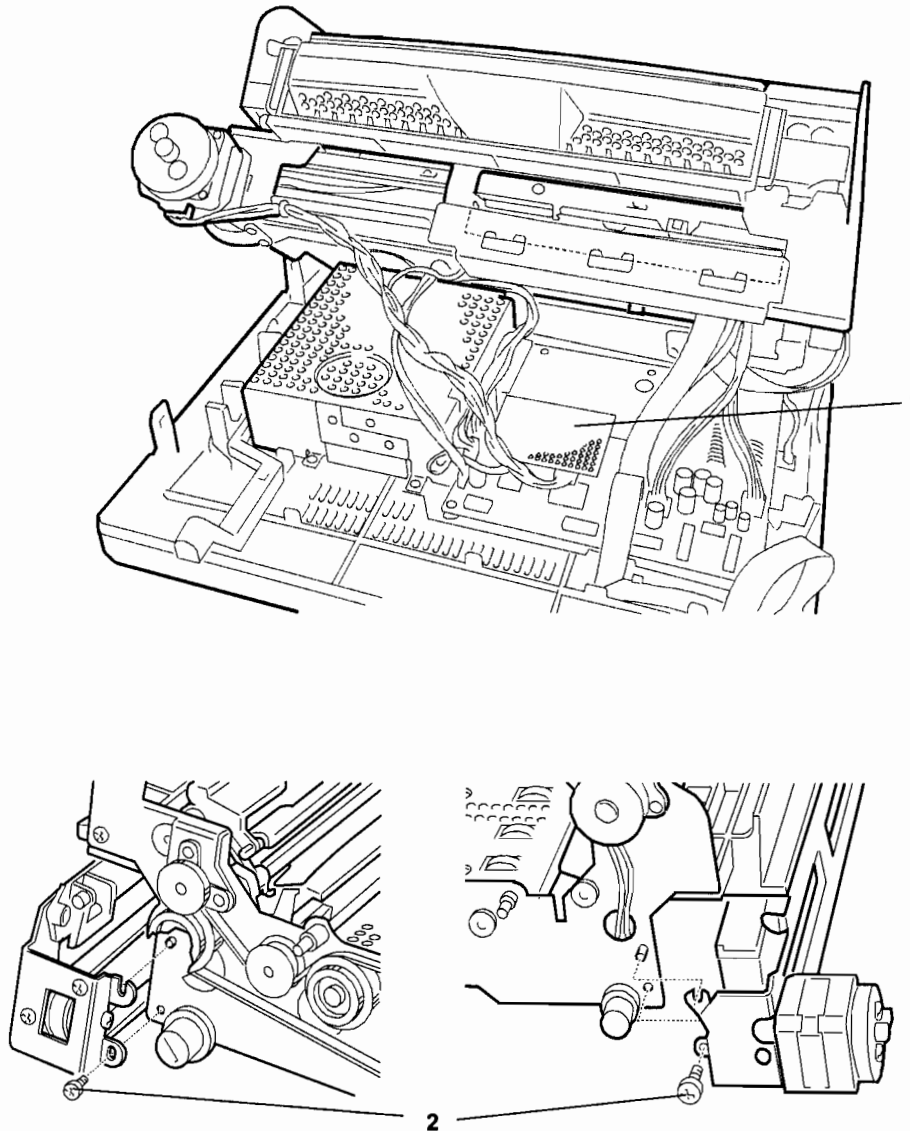


Fig. 9-23

**Note:** When refitting the assembly, adjust its position on the frame (section 8.12).

### 9.3.2 HORIZONTAL MAGNETIC DEVICE/MICR MOTOR DISASSEMBLY/REASSEMBLY

- Remove the printer case (section 9.2.1).
- Remove the horizontal magnetic device/MICR assy (section 9.3.1).
- Unplug the motor cable from the magnetic options card.
- Loosen the two screws (1) and then remove the motor with its related protective shield.

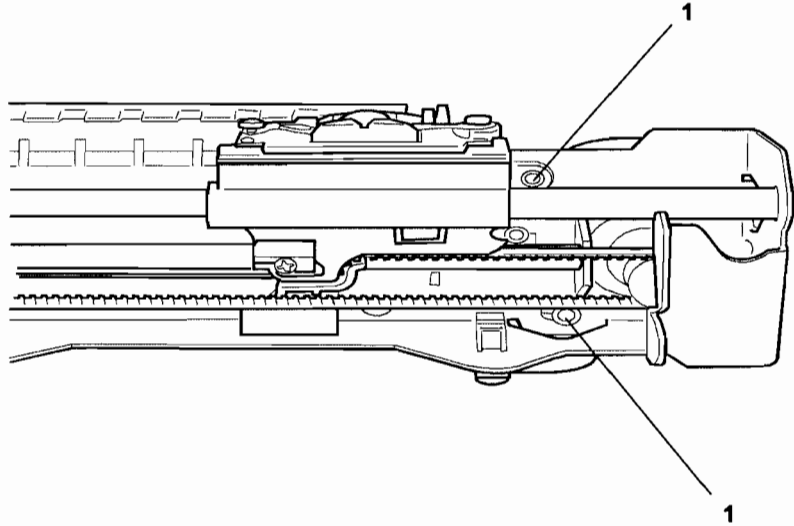
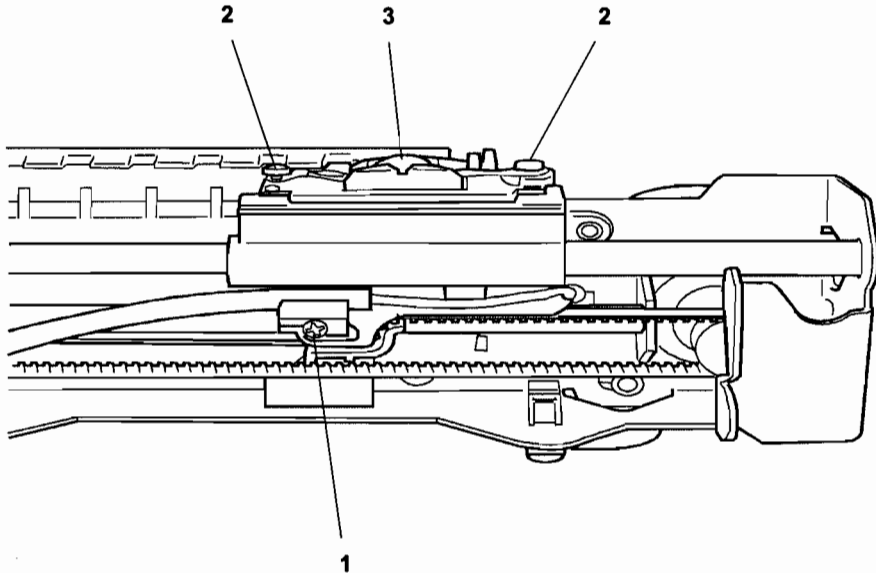


Fig. 9-24

### 9.3.3 HORIZONTAL MAGNETIC DEVICE/MICR HEAD ASSY DISASSEMBLY/ REASSEMBLY

- Remove the printer case (section 9.3.1).
- Remove the horizontal magnetic device/MICR (section 9.3.1).
- Loosen screw (1) to free the signals cable.
- Loosen screws (2) and remove the MICR head (3).



*Fig. 9-25*

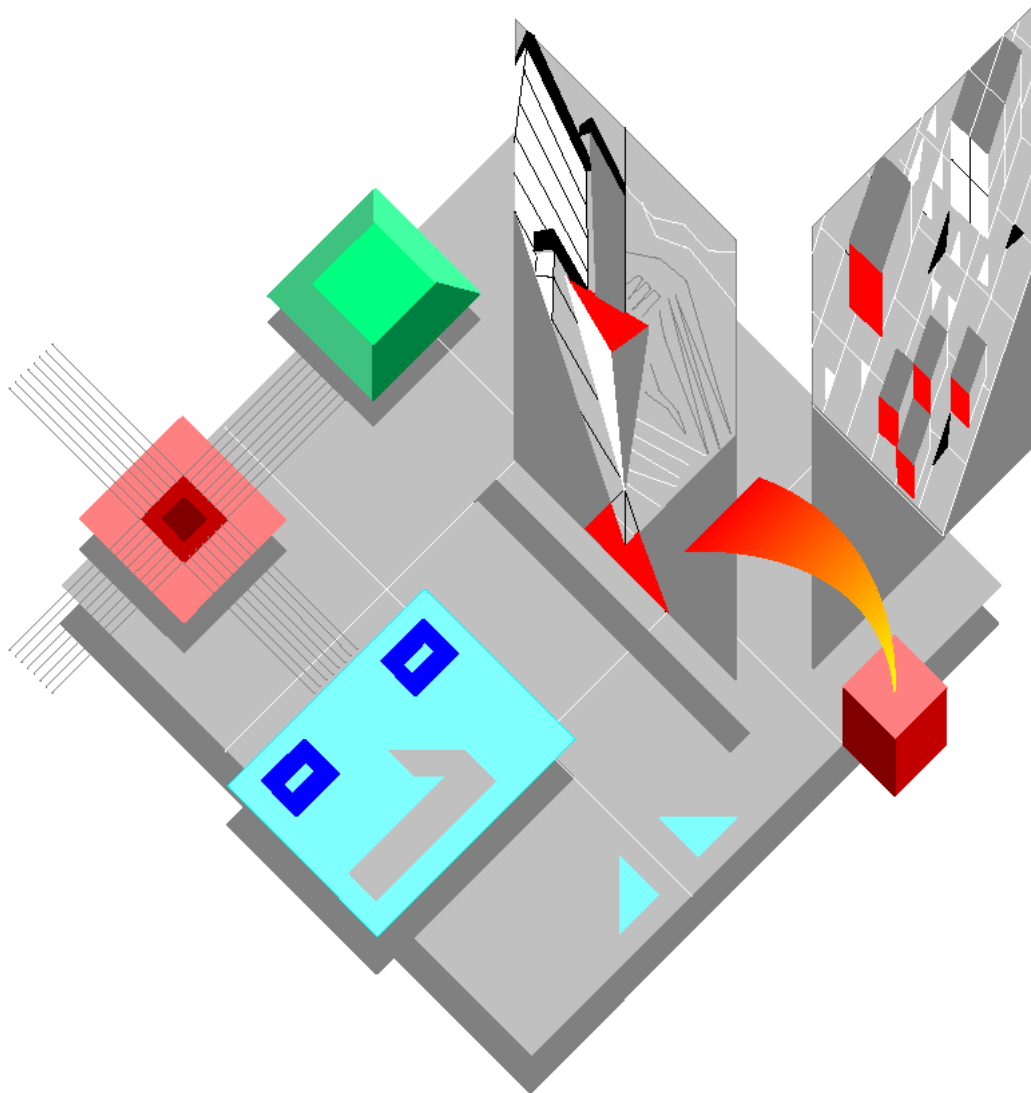


STAMPANTE

# PR2 E

CATALOGO PARTI DI RICAMBIO

Codice XYAA2112-03



## **PUBBLICAZIONE EMESSA DA :**

**Olivetti S.p.A.**  
Via Camillo Olivetti , 8  
10011 Agliè ( Italia )

**Copyright © 2006, by Olivetti**  
**Tutti i diritti riservati**

**Stampato in Italia da :**

---

### **IMPORTANTE**

PUBBLICAZIONE REDATTA DA OLIVETTI S.p.A (GESTIONE RICAMBI E SCORTE).  
QUESTO CATALOGO E' L' UNICO DOCUMENTO AL QUALE FARE RIFERIMENTO PER  
ORDINARE LE PARTI DI RICAMBIO.

---

### **STATO DI AGGIORNAMENTO**

<b>DATA</b>	<b>CODICE</b>
<b>03/2003</b>	<b>XYAA2112</b>
<b>03/2004</b>	<b>XYAA2112-01</b>
<b>01/2006</b>	<b>XYAA2112-02</b>
<b>032006</b>	<b>XYAA2112-03</b>





## INDICE

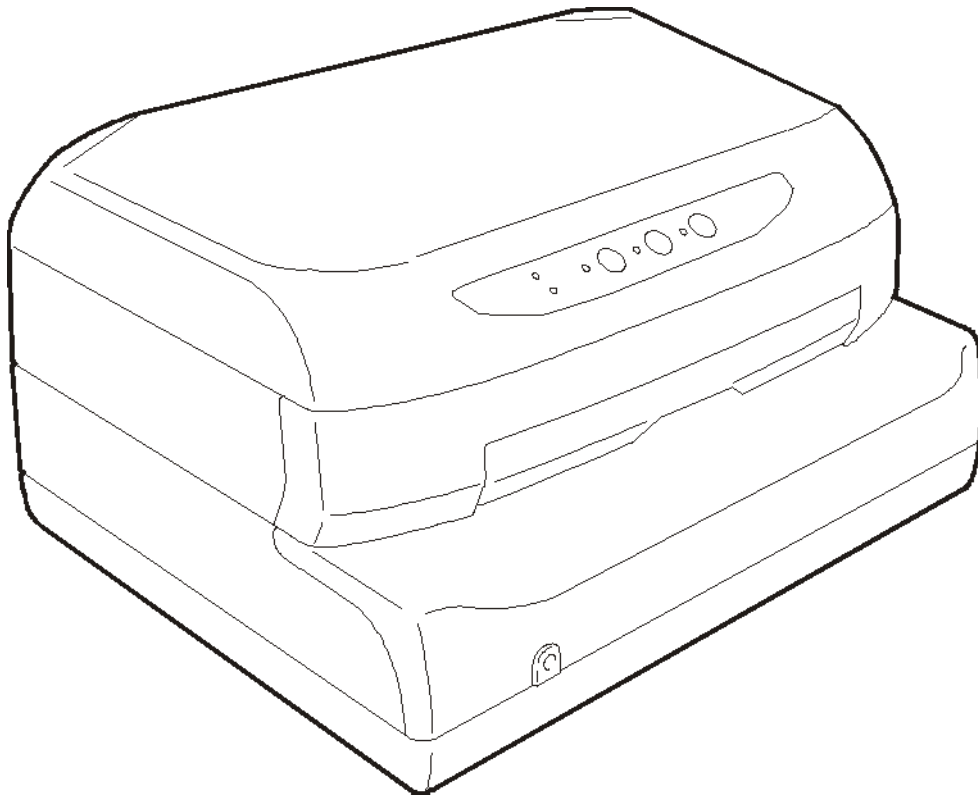
COMPLESSIVO.....	3
MODELLI .....	4
CARROZZERIA.....	5
GRUPPO FONDELLO E ALIMENTATORE .....	6
GRUPPO STRUTTURA INFERIORE 1.....	7
GRUPPO STRUTTURA INFERIORE 2.....	8-9
GRUPPO STRUTTURA INFERIORE 3.....	10
GRUPPO PRESSORI POSTERIORI .....	11
GRUPPO STAMPA .....	12-13
PIASTRE ELETTRONICHE .....	14
MINUTERIA.....	15
GRUPPO STRUTTURA INFERIORE CON MAGNETICO ORIZZONTALE .....	16
GRUPPO MAGNETICO ORIZZONTALE / MICR.....	17
GRUPPO STRUTTURA INFERIORE PASSAPORTO .....	18
GRUPPO STRUTTURA INFERIORE CON MAGNETICO VERTICALE .....	19
GRUPPO PRESSORI POSTERIORI CON MAGNETICO VERTICALE .....	20
GRUPPO STRUTTURA INFERIORE SCANNER .....	21
GRUPPO PRESSORI POSTERIORI SCANNER .....	22
GRUPPO SCANNER .....	23

<b>INDICE GENERALE DEI CODICI</b>	<b>24</b>
-----------------------------------	-----------



**COMPLESSIVO**

**PR2E**



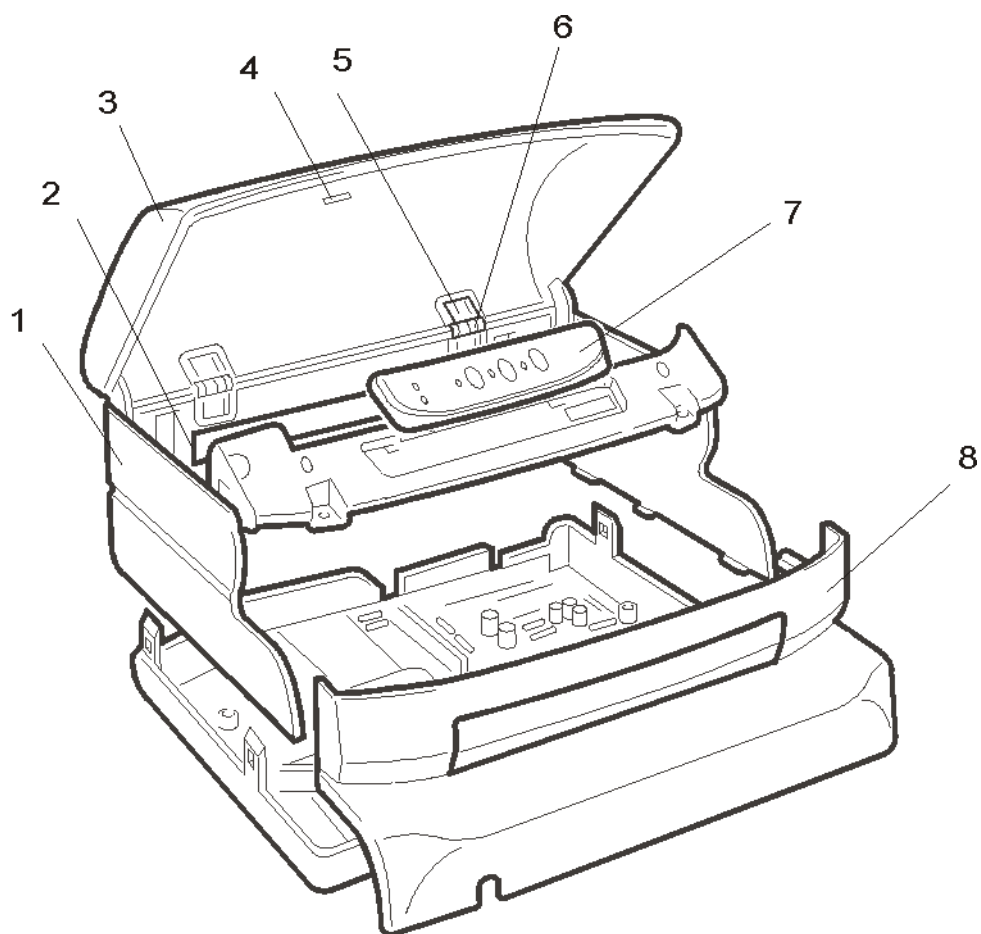
**MODELLI****PR2E**

<b>MODELLO</b>	<b>DESCRIZIONE</b>
PR2 S 10 E	MODELLO BASE
PR2 S 10 E PASS	MODELLO PASSAPORTO
PR2 S 12 E	MODELLO MAGNETICO ORIZZONTALE
PR2 S 12 M E	MODELLO MICR
PR2 S 13 E	MODELLO MAGNETICO VERTICALE
PR2 P 10 E SC/F	MODELLO SCANNER FRONT
PR2 U 10 E SC/F B	MODELLO SCANNER FRONT / BACK

# CARROZZERIA

PR2E

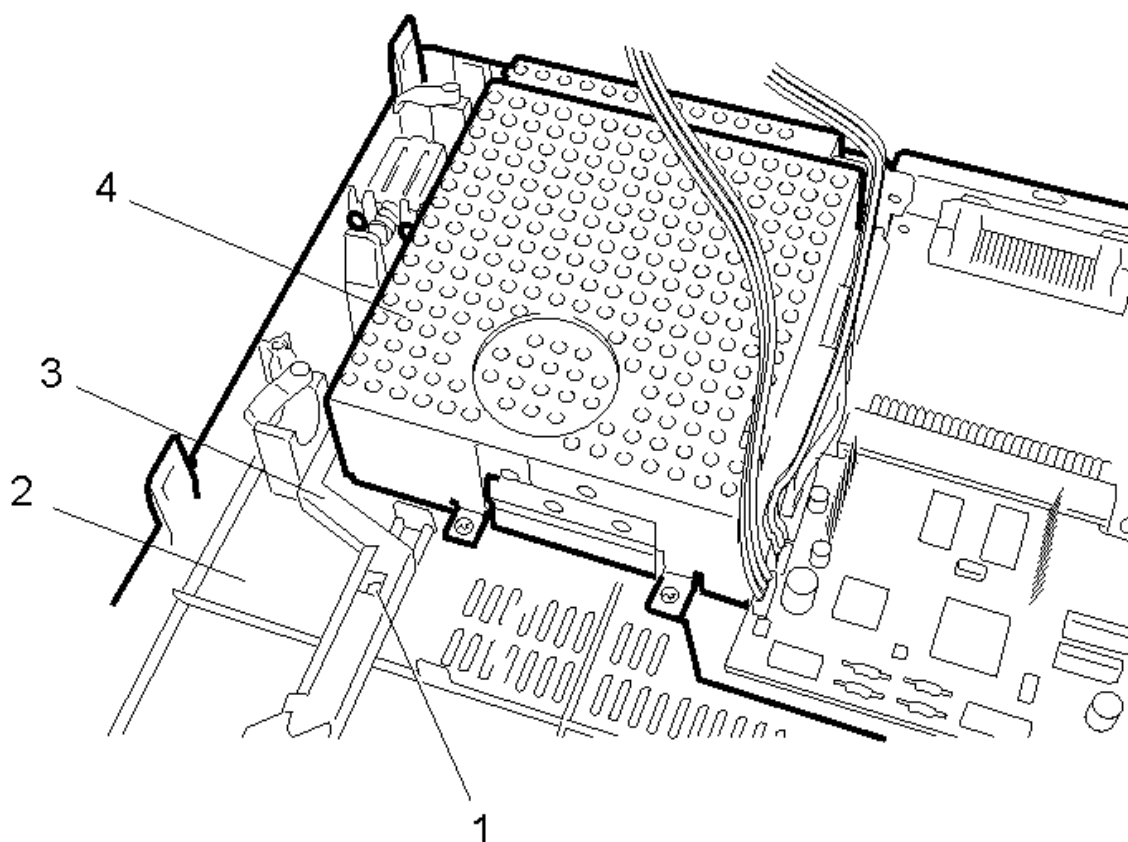
RIF.	CODICE	DESCRIZIONE	10 E	10 E PASS	12 E M.OR	12 M E MICR	13 E M.VER	10 E SC/F	10 E SC/F B
1	XYAA3415	GRUPPO SCOCCA	•	•	•	•	•	•	•
2	XYAA3407	RIPARO POSTERIORE	•	•	•	•	•	•	•
3	XYAA3411	GRUPPO COPERTURA SUPERIORE	•	•	•	•	•	•	•
4	752610 J	MAGNETE PER COPERTURA	•	•	•	•	•	•	•
5	473540 D	CERNIERA	•	•	•	•	•	•	•
6	759410 R	PERNO PER CERNIERA	•	•	•	•	•	•	•
7	XYAA3406	CONSOLE	•	•	•	•	•		
8	XYAA3409	GRUPPO FRONTALE	•	•	•	•	•	•	•



## GRUPPO FONDELLO E ALIMENTATORE

PR2E

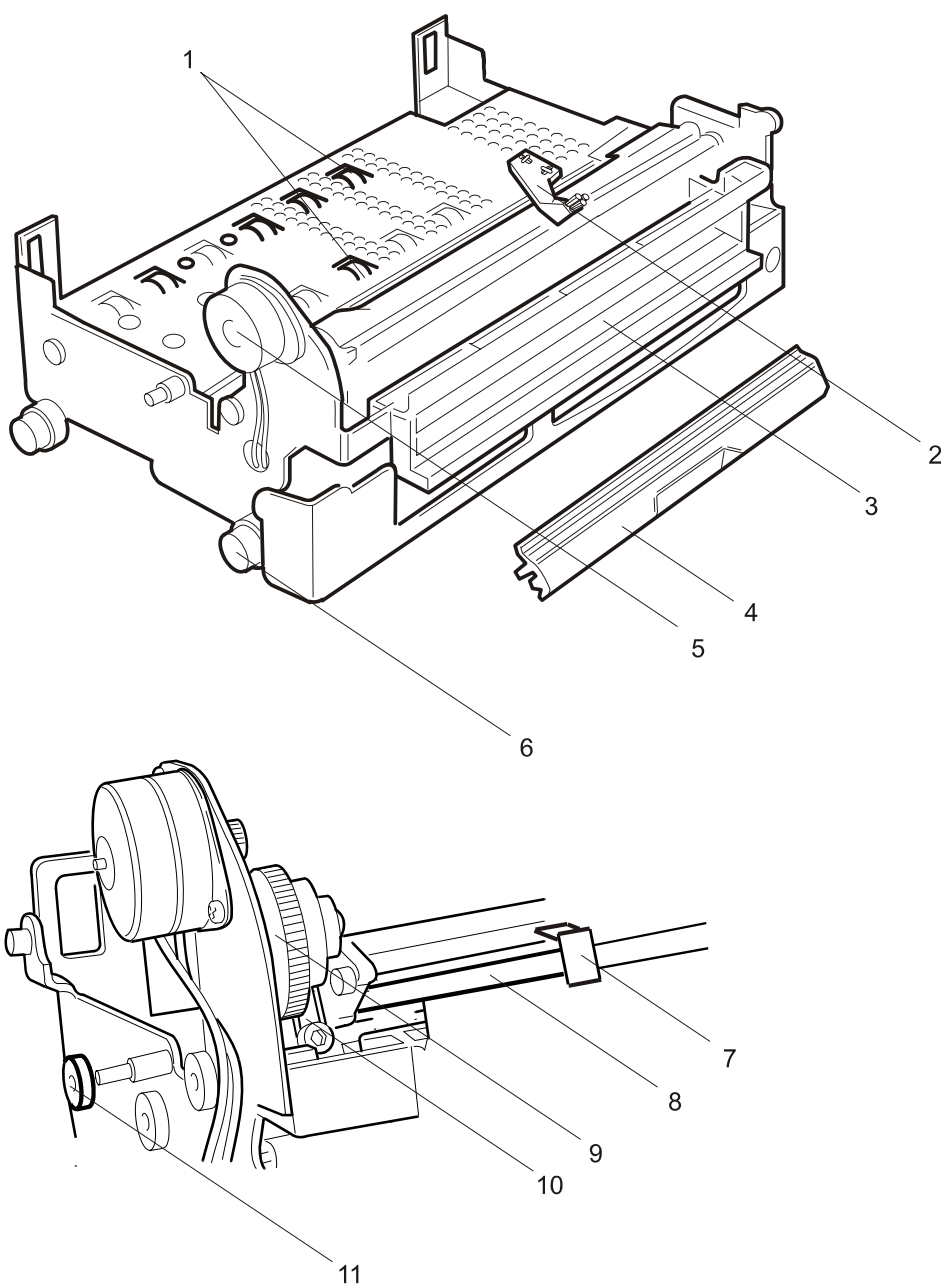
RIF.	CODICE	DESCRIZIONE	10 E	10 E PASS	12 E M.OR	12 M E MICR	13 E M.VER	10 E SC/F	10 E SC/F B
1	473034 R	MOLLA CORSOIO INTERRUETTORE	•	•	•	•	•	•	•
2	XYAA3400	GRUPPO FONDELLO TAPPETO ANTISCIVOLO	•	•	•	•	•	•	•
3	XYAA3575	CORSOIO INTERRUETTORE	•	•	•	•	•	•	•
4	XYAA5795 XYAA5796	GRUPPO ALIMENTATORE 220V GRUPPO ALIMENTATORE 115V	•	•	•	•	•	•	•



# GRUPPO STRUTTURA INFERIORE 1

PR2E

RIF.	CODICE	DESCRIZIONE	10 E	10 E PASS	12 E M.OR	12 M E MICR	13 E M.VER	10 E SC/F	10 E SC/F B
1	473028 T	GRUPPO ALBERI DI TRASCINAMENTO	•	•	•	•			
2	395055 Y	PENNELLO	•	•	•	•	•	•	•
3	XYAA6332	GRUPPO FIBRE OTTICHE RICO	•	•			•	•	•
4	XYAA3419	SPORTELLO DEFLETTORE	•		•		•		
5	473069 C	GRUPPO MOTORE SERVIZI	•	•	•	•	•	•	•
6	395038 X	GOMMINO SMORZATORE STRUTTURA	•	•	•	•	•	•	•
7	473075 S	PORTAMOLLA PRESSORI	•	•	•	•	•	•	•
8	473073 Y	ALBERO SUPPORTO PRESSORI	•	•	•	•	•	•	•
9	473072 X	CAMMA SERVIZI	•	•	•	•	•	•	•
10	473074 Z	PONTE COMANDO PRESSORI	•	•	•	•	•	•	•
11	473018 Z	BOCCOLA SINISTRA	•	•	•	•	•	•	•



## GRUPPO STRUTTURA INFERIORE 2

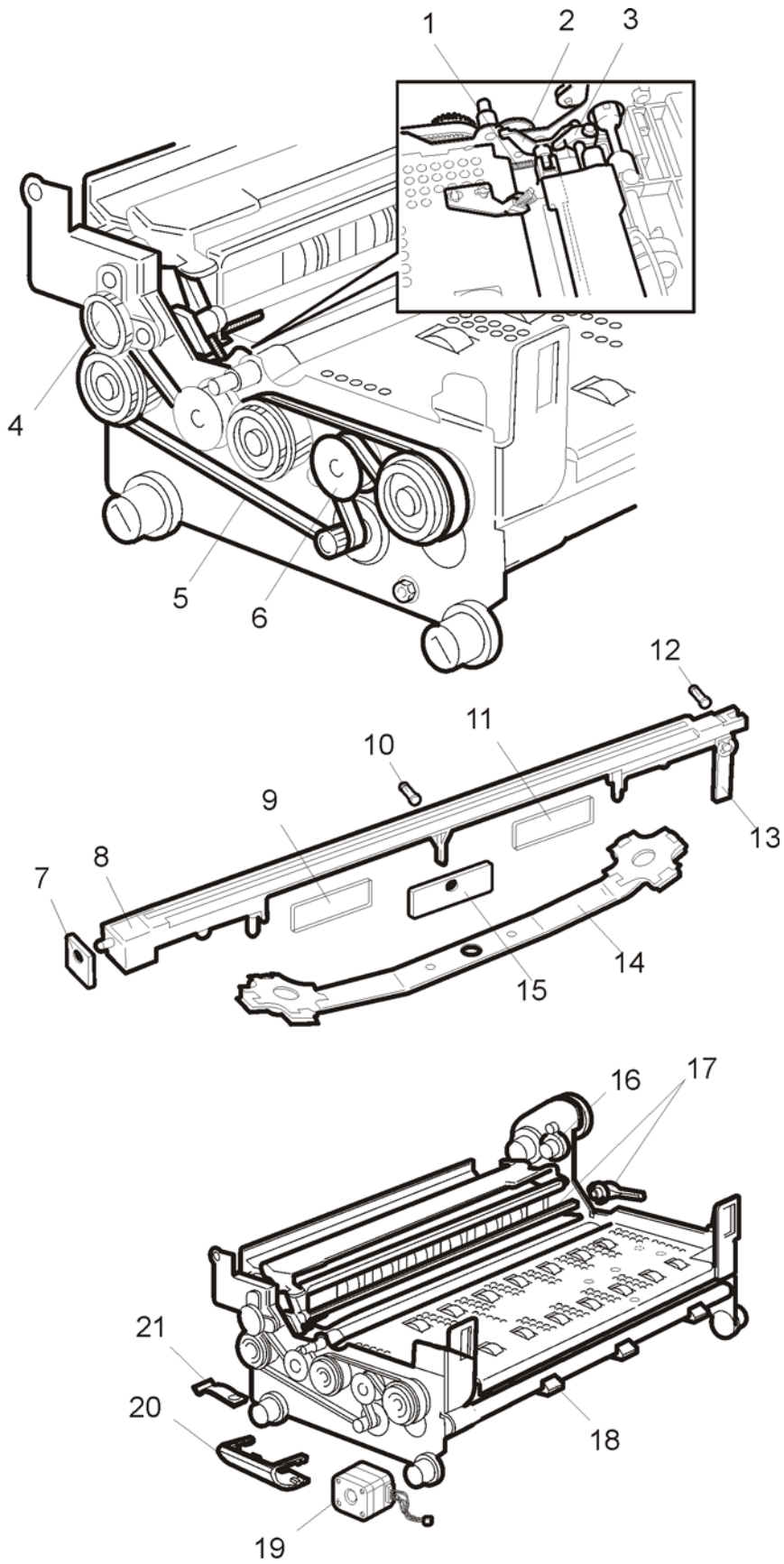
PR2E

RIF.	CODICE	DESCRIZIONE	10 E	10 E PASS	12 E M.OR	12 M E MICR	13 E M.VER	10 E SC/F	10 E SC/F B
1	473052 T	MOLLA GRUPPO BANDELLA	•	•	•	•	•	•	•
2	473050 D	BILANCIERE COMANDO BANDELLA	•	•	•	•	•	•	•
3	473051 S	MANOVELLA COMANDO BANDELLA	•	•	•	•	•	•	•
4	473174 S	GRUPPO COMANDO RULLINI PRESSORI	•	•	•	•	•	•	•
5	751171 D	CINGHIA TRASC. DOCUM. (Z=210)	•	•	•	•	•	•	•
6	473479 C	PULEGGIA TENDICINGHIA	•	•	•	•	•	•	•
7	473049 G	ZAVORRA SINISTRA	•	•	•	•	•	•	•
8	395116 S	GRUPPO TRAVERSA DI STAMPA	•		•	•	•	•	•
9	395153 X	SILENZ. TRAVERSA STAMPA POSTERIORE	•	•	•	•	•	•	•
10	473056 X	PERNO PER ZAVORRA CENTRALE	•	•	•	•	•	•	•
11	395152 W	SILENZ. TRAVERSA STAMPA ANTERIORE	•	•	•	•	•	•	•
12	473047 W	PERNO PER ZAVORRA DESTRA	•	•	•	•	•	•	•
13	473048 F	ZAVORRA DESTRA	•	•	•	•	•	•	•
14	475871 X	GR. BALESTRA AMMORTIZZATORI	•	•	•	•	•	•	•
15	473058 H	ZAVORRA CENTRALE	•	•	•	•	•	•	•
16	473071 W	INGRANAGGIO DI RINVIO	•	•	•	•	•	•	•
17	XYAA7928	GRUPPO BANDELLA IN RESINA CON LEVA	•	•	•	•		•	•
18	XYAA3394	SCHERMO RULLINI	•	•	•	•	•	•	•
19	473020 X	GRUPPO MOTORE INTERLINEA	•	•	•	•		•	•
20	473012 K	STAFFA GUIDA FLAT	•	•	•	•	•	•	•
21	759413 G	STAFFA DI FISSAGGIO MECCANICA	•	•	•	•	•	•	•



# GRUPPO STRUTTURA INFERIORE 2

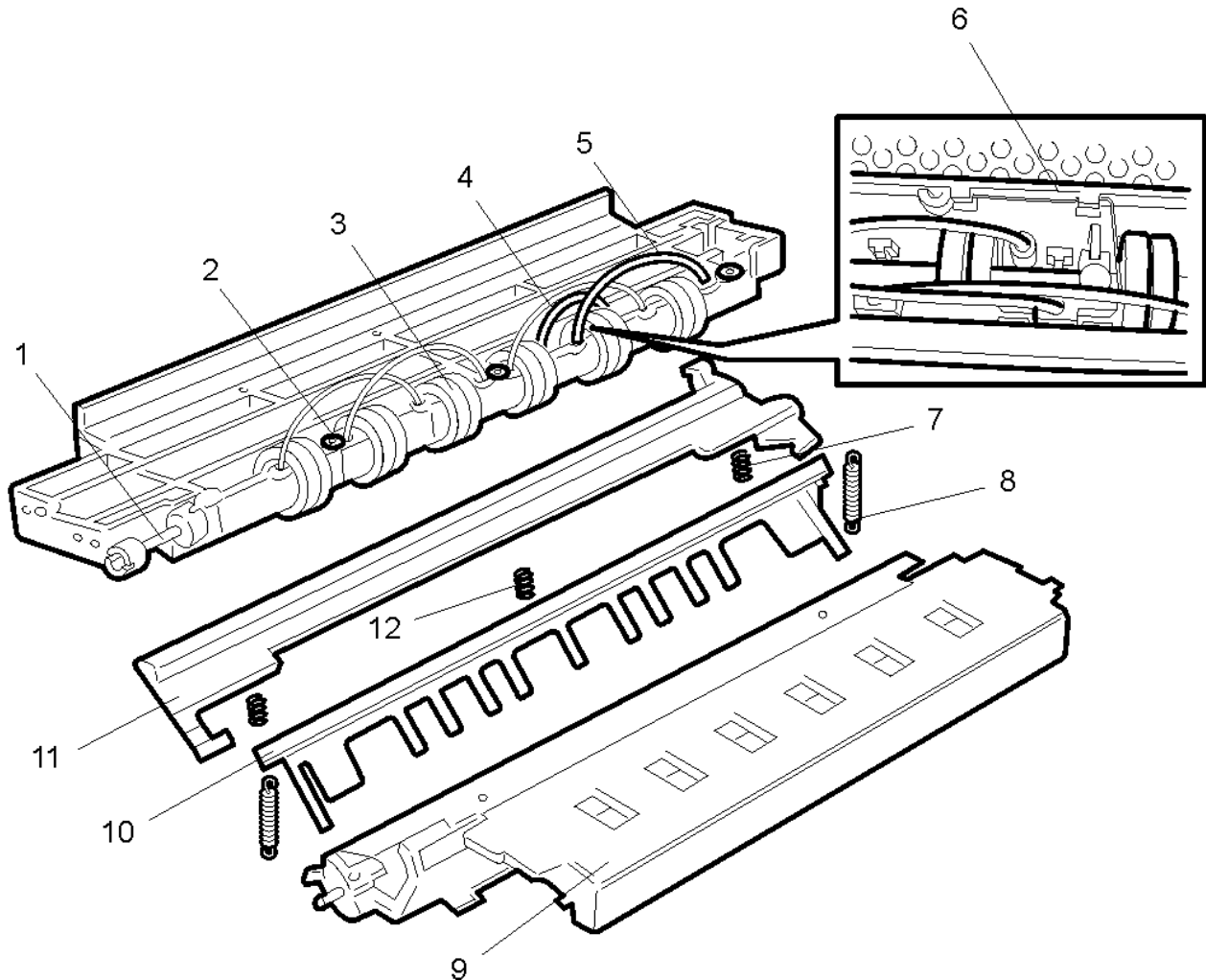
PR2E



# GRUPPO STRUTTURA INFERIORE 3

PR2E

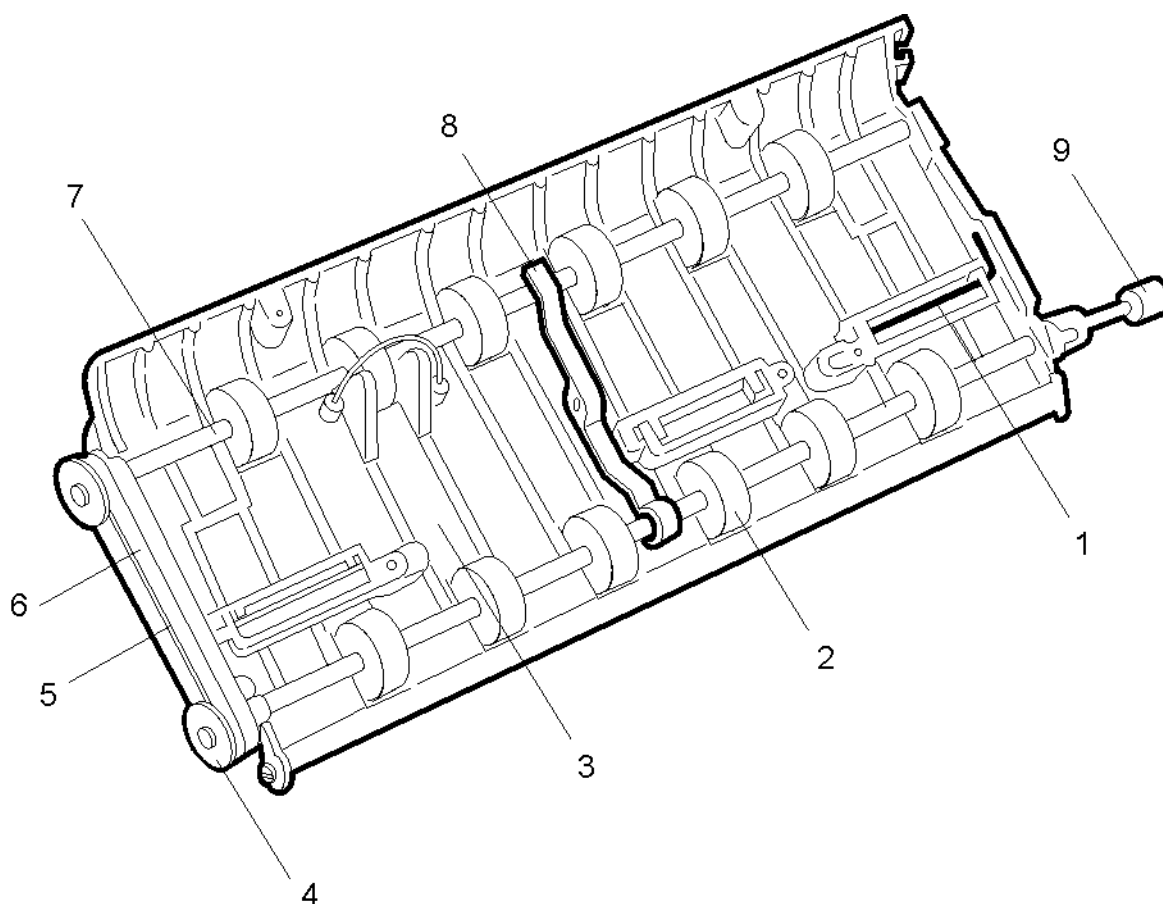
RIF.	CODICE	DESCRIZIONE	10 E	10 E PASS	12 E M.OR	12 M E MICR	13 E M.VER	10 E SC/F	10 E SC/F B
1	473175 T	GIUNTO	•	•	•	•	•	•	•
2	474953 Y	BOCCOLA	•	•	•	•	•	•	•
3	474943 W	GRUPPO RULLINI ALLINEAMENTO			•	•			
4	473192 M	FIBRA OTTICA L=80			•	•			
5	473191 L	FIBRA OTTICA L=100			•	•			
6	473091 K	MOLLA RULLINI ALLINEAMENTO			•	•			
7	473083 K	MOLLA PRESSORE	•	•	•	•	•	•	•
8	473265 D	MOLLA PETTINE	•	•	•	•	•	•	•
9	473085 M	SUPPORTO CARTA FOTO ANTERIORE	•	•	•	•	•	•	•
10	473077 U	PETTINE	•	•	•	•	•	•	•
11	474954 Z	SUPPORTO PETTINE	•	•	•	•	•	•	•
12	473197 J	MOLLA PRESSORE NERA	•	•	•	•	•	•	•



## GRUPPO PRESSORI POSTERIORI

PR2E

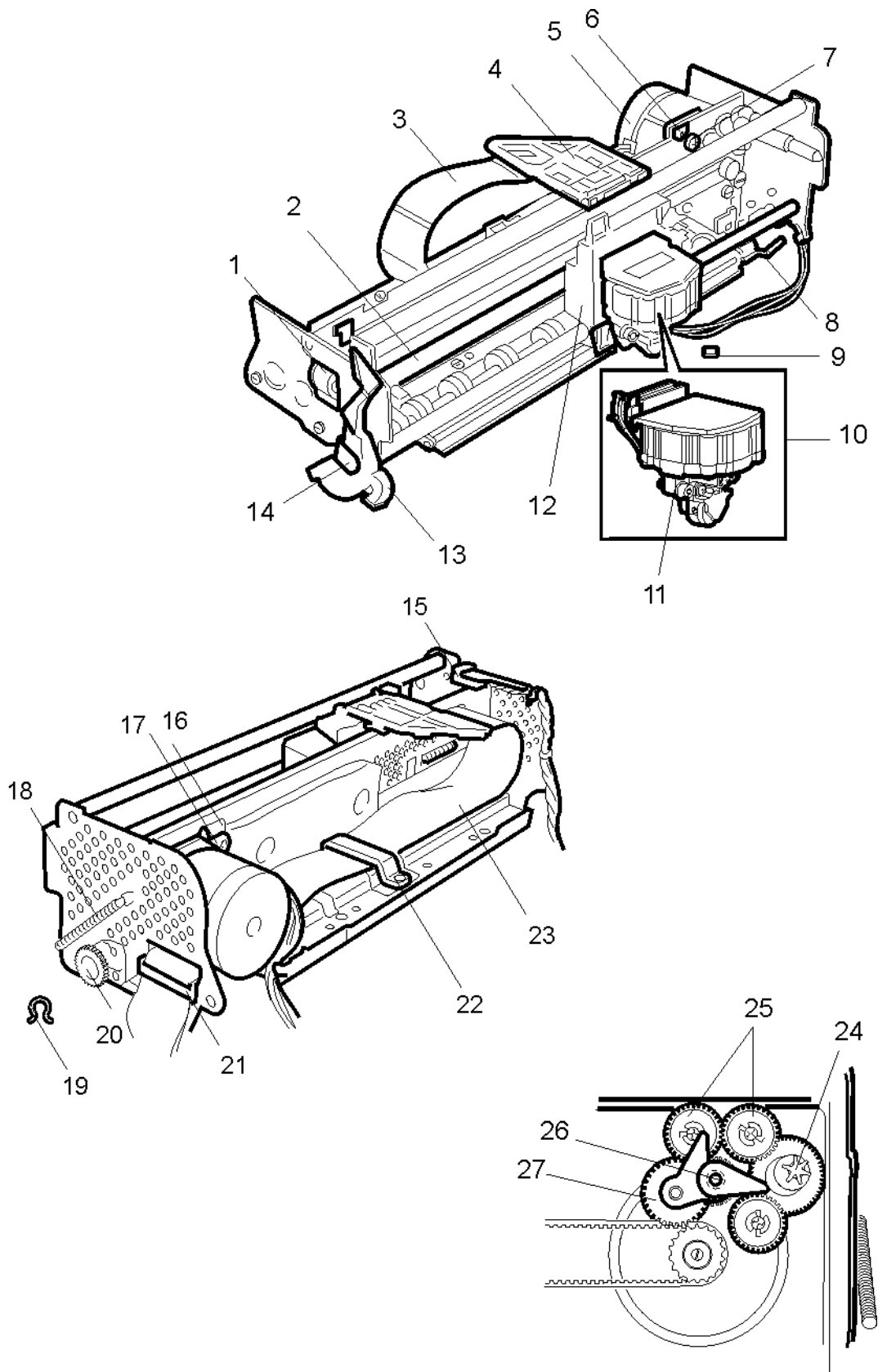
RIF.	CODICE	DESCRIZIONE	10 E	10 E PASS	12 E M.OR	12 M E MICR	13 E M.VER	10 E SC/F	10 E SC/F B
1	473173 Z	MOLLA TORSIONE	•	•	•	•		•	•
2	473244 G	GRUPPO RULLINI ANTERIORI	•	•	•	•			
3	395079G	SUPPORTO PRESSORI	•	•	•	•		•	•
4	473166 S	PULEGGIA	•	•	•	•		•	•
5	473172 Y	CINGHIA DENTATA Z=28	•	•	•	•		•	•
6	473171 X	BOCCOLA SINISTRA	•	•	•	•		•	•
7	473248 L	GRUPPO RULLINI PRESSORI POSTERIORI	•	•	•	•			
8	473167 T	BOCCOLA CENTRALE	•	•	•	•			
9	473175 T	GIUNTO	•	•	•	•	•	•	•



## GRUPPO STAMPA

PR2E

RIF.	CODICE	DESCRIZIONE	10 E	10 E PASS	12 E M.OR	12 M E MICR	13 E M.VER	10 E SC/F	10 E SC/F B
1	751272 J	PULEGGIA DI RINVIO	•	•	•	•	•	•	•
2	473123 P	CINGHIA TRASPORTO CARRELLO	•	•	•	•	•	•	•
3	473135 K	SCHERMO FLAT TESTINA	•	•	•	•	•	•	•
4	473137 M	SUPPORTO FLAT	•	•	•	•	•	•	•
5	475601 H	GRUPPO MOTORE TRASPORTO	•	•	•	•	•	•	•
6	473141 Z	AMMORTIZZATORE MOTORE TRASPORTO	•	•	•	•	•	•	•
7	471244 E	STUD PER FISSAGGIO MOTORE	•	•	•	•	•	•	•
8	473127 K	ALBERO SUPPORTO CARRELLO	•	•	•	•	•	•	•
9	473150 E	FELTRO LUBRIFICAZIONE CARRELLO	•	•	•	•	•	•	•
10	XYAA1264	GRUPPO TESTINA DI STAMPA IMBALLATA	•	•	•	•	•	•	•
11	474996 L	GRUPPO FOTOSENSORE TASTATURA	•	•	•	•	•	•	•
12	395133 K	CARRELLO SUPPORTO TESTINA	•	•	•	•	•	•	•
13	474999 X	LEVA APERTURA STRUTTURA SUPERIORE	•	•	•	•	•	•	•
14	473158 A	STAFFA COLLEGAMENTO TERRA PER LEVA	•	•	•	•	•	•	•
15	395060 H	FOTO AZZERAMENTO CARRELLO	•	•	•	•	•	•	•
16	473156 Y	STAFFA COLLEGAMENTO TERRA	•	•	•	•	•	•	•
17	710769 X	PIASTRINO FISSAGGIO MOTORE TRASPORTO	•	•	•	•	•	•	•
18	473151 T	MOLLA PER LEVA DI BLOCCAGGIO	•	•	•	•	•	•	•
19	473182 K	BALESTRINA PER GRUPPO BOCCOLA	•	•	•	•	•	•	•
20	473180 V	GRUPPO COMANDO RULLINI PRESSORI	•	•	•	•	•	•	•
21	473139 X	STAFFA DX GUIDA FLAT	•	•	•	•	•	•	•
22	473138 W	STAFFA BLOCCAGGIO FLAT	•	•	•	•	•	•	•
23	474400 B	FLAT TESTINA	•	•	•	•	•	•	•
24	395143 V	LANCIA	•	•	•	•	•	•	•
25	XYAA9394	RUOTA TRASCINAMENTO NASTRO	•	•	•	•	•	•	•
26	473498 Y	SCAMBIATORE	•	•	•	•	•	•	•
27	473131 P	INGRANAGGIO COMANDO NASTRO	•	•	•	•	•	•	•

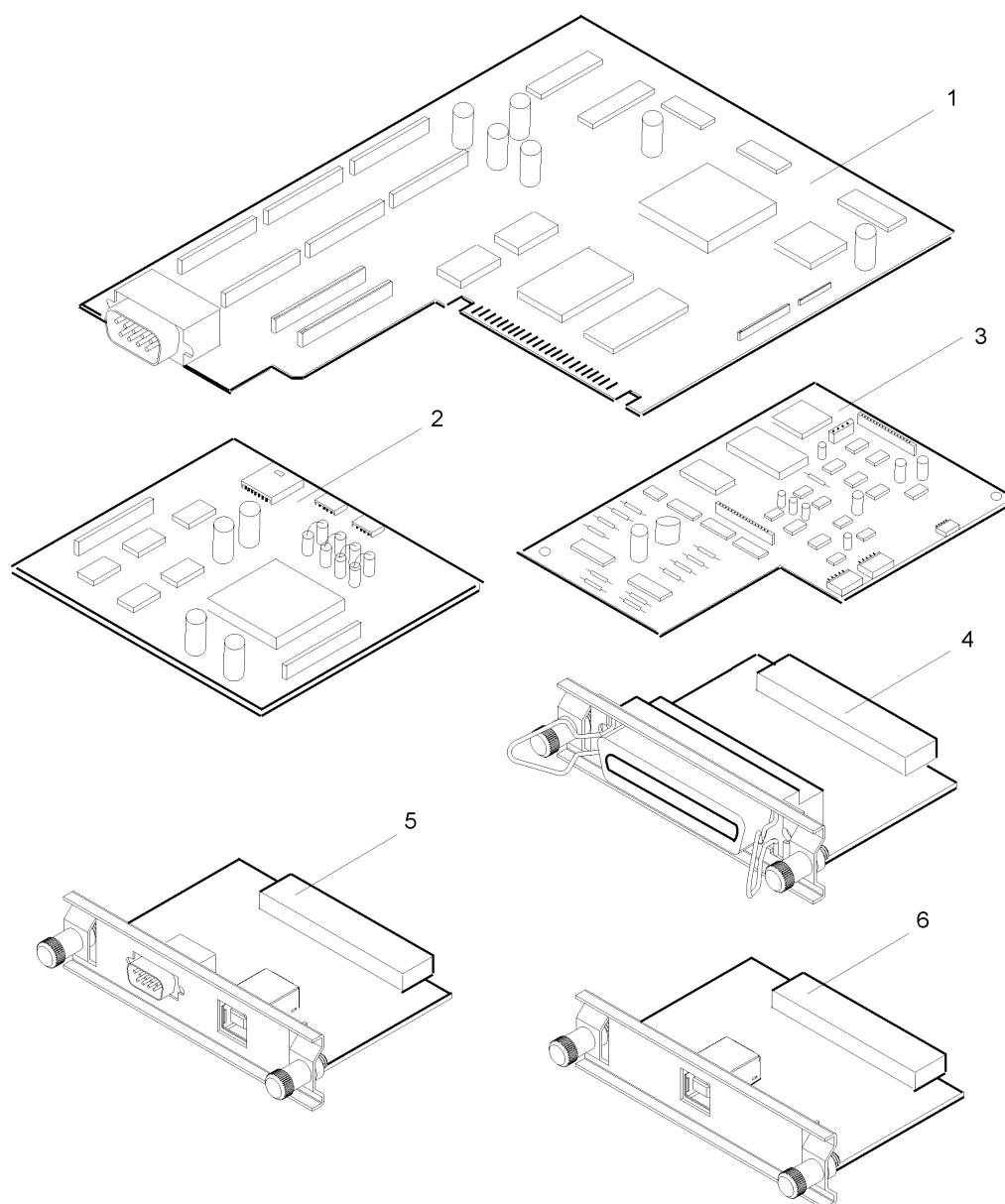


# PIASTRE ELETTRONICHE

# PR2E

RIF.	CODICE	DESCRIZIONE	10 E	10 E PASS	12 E M.OR	12 M E MICR	13 E M.VER	10 E SC/F	10 E SC/F B
1	128589 Z	PIASTRA BASE SERIALE – BAPR2E	•	•	•	•	•	•	•
2	XYAA1885	PIASTRA MAGNETICO ORIZZONTALE			•				
	XYAA2037	PIASTRA MAGNETICO VERTICALE <b>DX SX</b>					•		
3	XYAA5699	PIASTRA MICR PR2E				•			
4	( *) B6862	<b>PRM45</b> - PIASTRA CENTRONICS	•	•	•	•	•	•	•
	XYAA6388	PIASTRA SCANNER CENTRONICS PR2E						•	•
5	( *) B6877	<b>PRM40</b> - PIASTRA USB – RS232	•	•	•	•	•	•	•
6	XYAA6389	PIASTRA SCANNER USB PR2E						•	•

( \* ) ORDINARE A OLIVETTI TECNOST S.p.A.

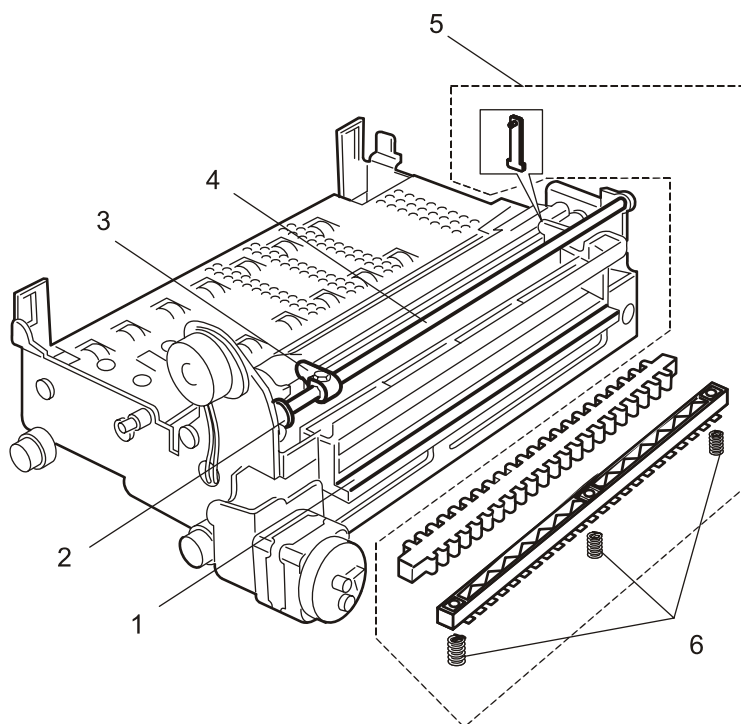


RIF.	CODICE	DESCRIZIONE
1	XYAA2102	KIT VITI <ul style="list-style-type: none"> <li>- Nr. 10 viti M 4x6 con rondella</li> <li>- Nr. 10 viti Screwplast 2,9 x 9,5</li> <li>- Nr. 10 viti Screwplast 2,2 x 9,5</li> <li>- Nr. 10 viti autofilettante testa esagonale 2,9 x 16</li> <li>- Nr. 10 viti autofilettante testa esagonale 2,9 x 13</li> <li>- Nr. 10 viti Screwplast 6,5 x 2,9</li> <li>- Nr. 10 dadi autobloccanti M3</li> <li>- Nr. 10 colonnine esagonali</li> <li>- Nr. 10 rondelle dentate</li> <li>- Nr. 10 perni per schermo</li> <li>- Nr. 10 distanziali</li> <li>- Nr. 10 stud M3 4x1,5</li> </ul>
2	XYAA2109	KIT STAFFE ELASTICHE <ul style="list-style-type: none"> <li>- Nr. 30 staffe 1,9</li> <li>- Nr. 30 staffe 2,3</li> <li>- Nr. 30 staffe 3,2</li> <li>- Nr. 30 staffe 4</li> <li>- Nr. 30 staffe 5</li> <li>- Nr. 30 staffe 7</li> <li>- Nr. 30 staffe tenuta fonoassorbente</li> </ul>
3	XYAA2106	KIT PASSACAVI <ul style="list-style-type: none"> <li>- Nr. 10 passacavi</li> <li>- Nr. 10 passacavi</li> <li>- Nr. 10 passacavi</li> <li>- Nr. 20 ponticelli</li> <li>- Nr. 30 perni per insonorizzante</li> <li>- Nr. 5 fascette per smorzatore</li> <li>- Nr. 5 fascette per smorzatore</li> </ul>

# GR. STRUTTURA INF. CON MAGN.ORIZZ.

PR2E

RIF.	CODICE	DESCRIZIONE	10 E	10 E PASS	12 E M.OR	12 M E MICR	13 E M.VER	10 E SC/F	10 E SC/F B
1	XYAA3703	CONVOGLIATORE CARTA			•	•			
2	473315 X	MANOVELLA PER CAMMA			•	•			
3	473317 Z	MANOVELLA PRESSORE			•	•			
4	473314 W	ALBERO SUPPORTO PRESSORE			•	•			
5	473499 Z	GRUPPO TRAVERSA PRESSORE			•	•			
6	473320 G	MOLLA PRESSORE			•	•			

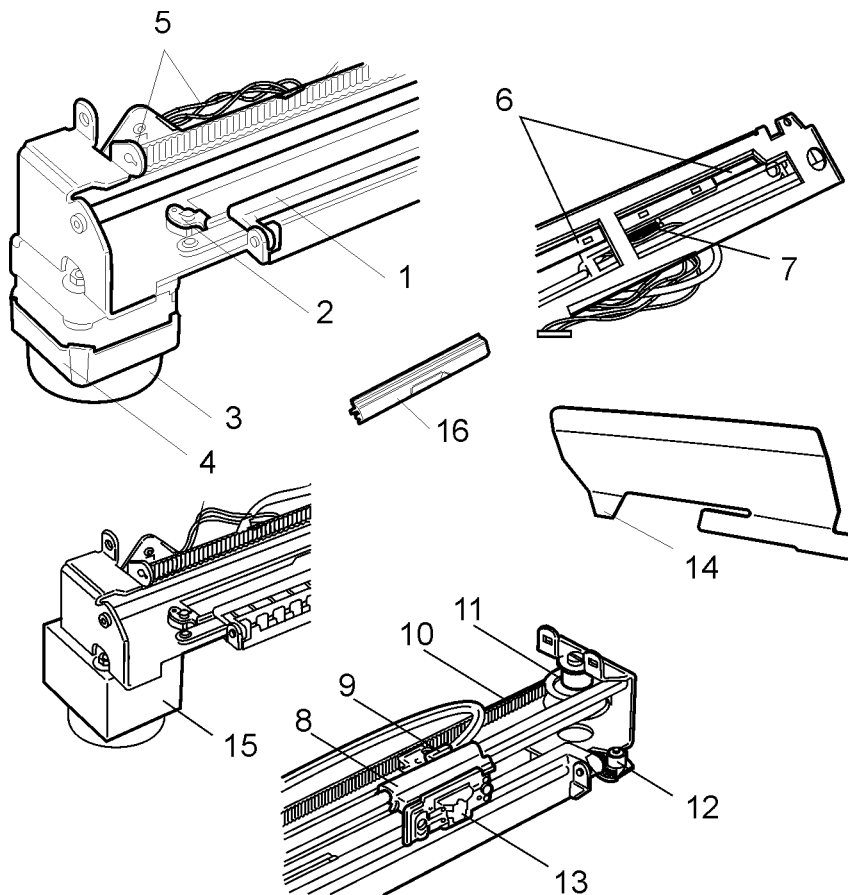




# GR. MAGNETICO ORIZZONTALE / MICR

PR2E

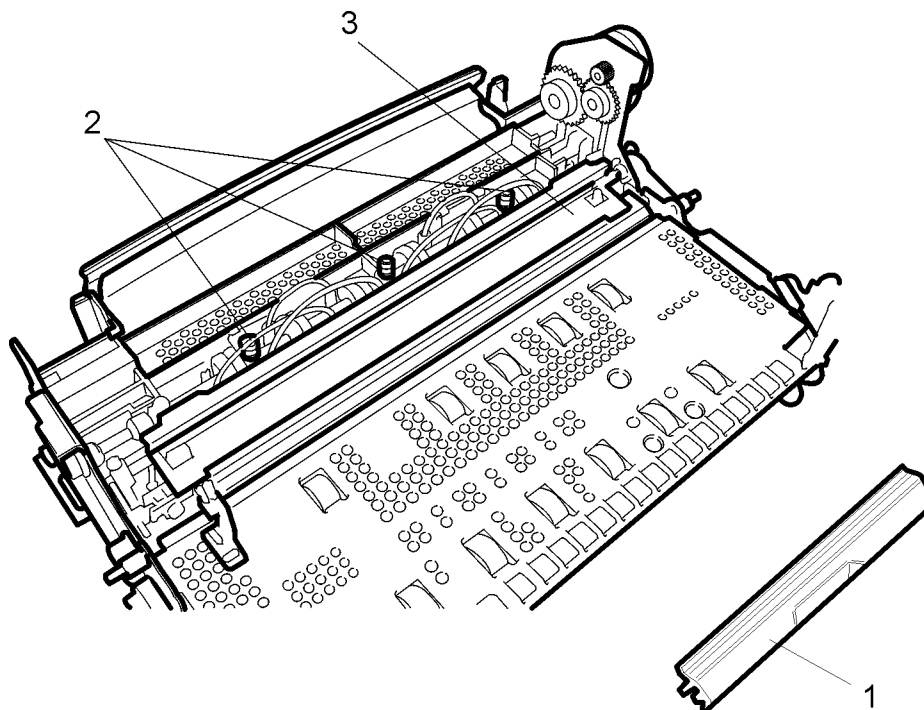
RIF.	CODICE	DESCRIZIONE	10 E	10 E PASS	12 E M.OR	12 M E MICR	13 E M.VER	10 E SC/F	10 E SC/F B
1	473486 L	SPORTELLINO DI CHIUSURA			•	•			
2	473285 S	PONTE APERTURA SPORTELLINO			•	•			
3	710682 H	SMORZATORE MOTORE TRASPORTO			•	•			
4	473308 R	GR. MOTORE TRASPORTO MAGN. ORIZZ.			•	•			
5	473330 A	GRUPPO FOTO AZZERAMENTO			•	•			
6	473309 J	GRUPPO SEMITIRANTE			•	•			
7	471514 M	MOLLA CHIUSURA SPORTELLINO			•	•			
8	474952 X	CARRELLO TESTINA MAGNETICA			•	•			
9	471501 Z	STAFFA BLOCC. TESTINA MAGNETICA			•	•			
10	473311 T	CINGHIA MAGNETICO ORIZZONTALE ( Z=360)			•	•			
11	473302 B	PULEGGIA DI RINVIO			•	•			
12	473303 C	SETTORE DENTATO			•	•			
13	XYAA6261	GR. TESTINA MAGNETICA ORIZZONTALE			•				
	XYAA6262	GR. TESTINA MAGN. MICR CON SCHERMO				•			
14	395047 Y	MYLAR			•	•			
15	473487 M	SCHERMO MOTORE MAGN. ORIZZ. / MICR				•			
16	474992 Q	SPORTELLINO DEFLETTORE MICR				•			
	XYAA3419	SPORTELLINO DEFLETTORE MAGNETICO ORIZZ.			•				



# GR. STRUTTURA INFERIORE PASSAPORTO

PR2E

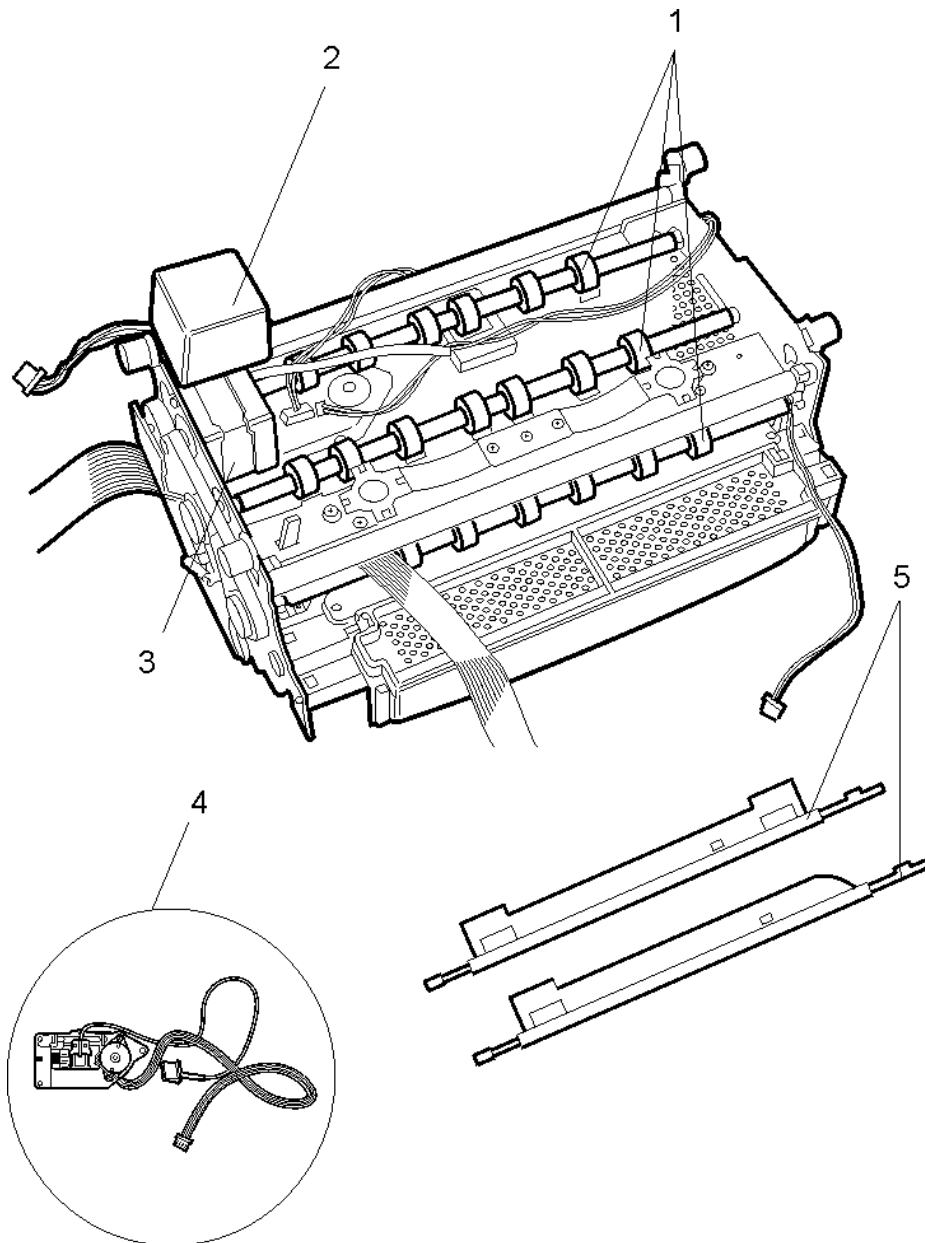
RIF.	CODICE	DESCRIZIONE	10 E	10 E PASS	12 E M.OR	12 M E MICR	13 E M.VER	10 E SC/F	10 E SC/F B
1	474990 S	SPORTELLO DEFLETTORE PASSAPORTO		•					
2	474967 W	MOLLE PRESSORI GIALLE		•					
3	XYAA0209	BARRA DI STAMPA PASSAPORTO		•					



# GR. STRUTTURA INFERIORE CON MAGNETICO VERTICALE

PR2E

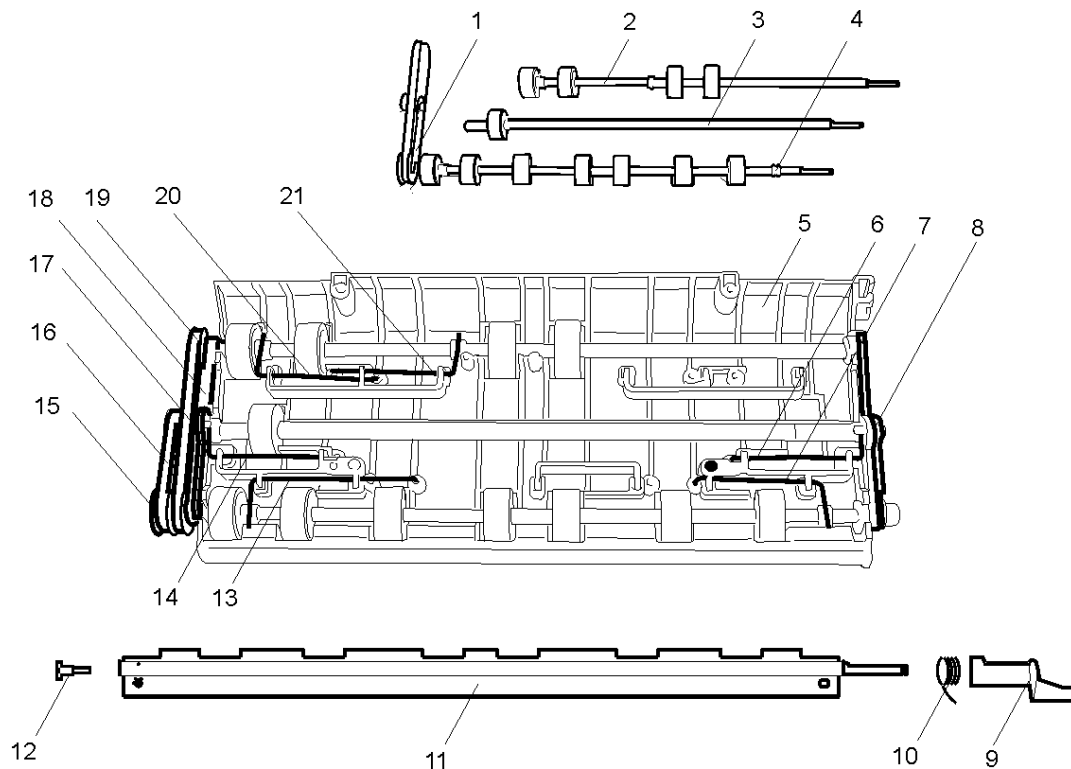
RIF.	CODICE	DESCRIZIONE	10 E	10 E PASS	12 E M.OR	12 M E MICR	13 E M.VER	10 E SC/F	10 E SC/F B
1	473376 C	GR. ALBERI TRASCINAMENTO MAGN. VERT. <b>SX</b>					•		
	473396 Z	GR. ALBERI TRASCINAMENTO MAGN. VERT. <b>DX</b>					•		
2	473346 E	SCHERMO MOTORE MAGN. VERTICALE <b>DX</b>					•		
3	473395 Y	MOTORE INTERLINEA MAGN. VERTICALE <b>DX</b>					•		
	473020 X	MOTORE INTERLINEA MAGN. VERTICALE <b>SX</b>					•		
4	150370 S	GRUPPO SUPPORTO MAGNETICO VERTICALE					•		
5	XYAA3017	BANDELLA PREMI CARTA <b>SX</b>					•		
	XYAA5322	BANDELLA PREMI CARTA <b>DX</b>					•		



# GR. PRESSORI POSTERIORI CON MAGNETICO VERTICALE

PR2E

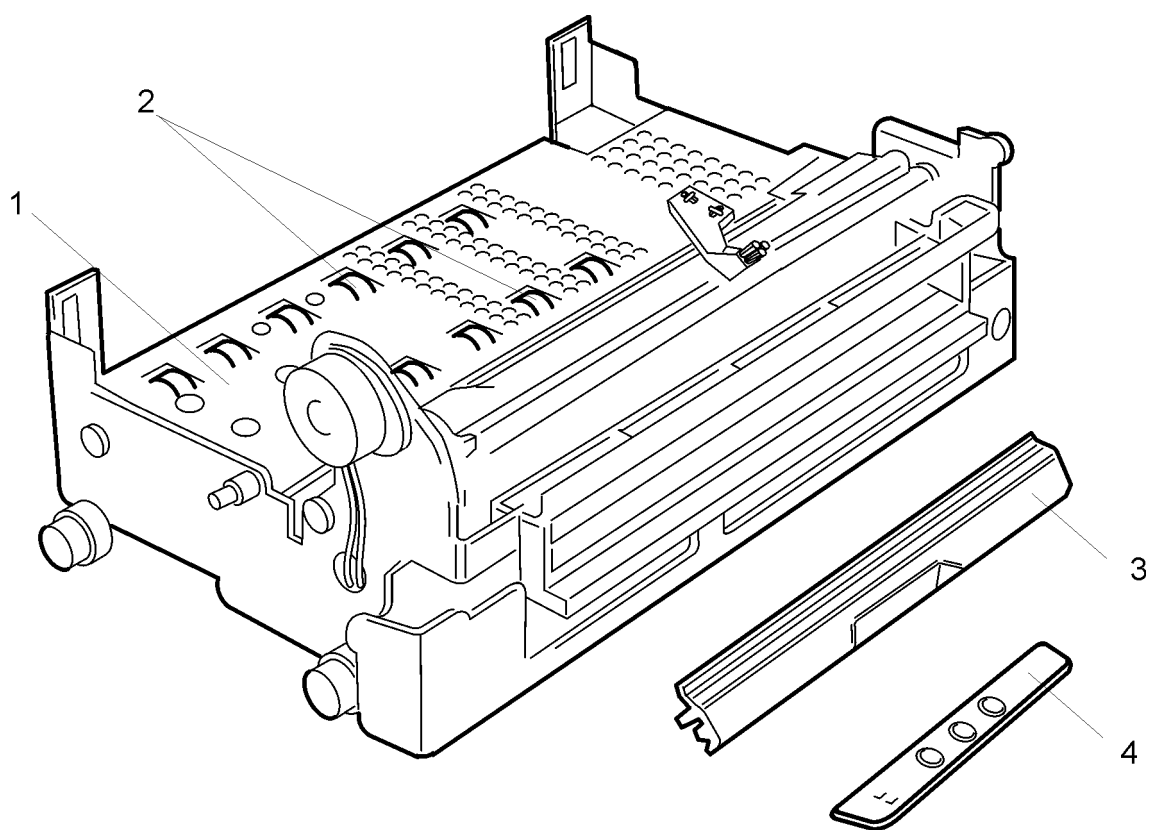
RIF.	CODICE	DESCRIZIONE	10 E	10 E PASS	12 E M.OR	12 M E MICR	13 E M.VER	10 E SC/F	10 E SC/F B
1	473364 G	GR. RULLINI ANTERIORI MAGN. VERT. <b>SX</b>					•		
	475932 L	GR. RULLINI ANTERIORI MAGN. VERT. <b>DX</b>					•		
2	473366 A	GR. ALBERO POSTERIORE MAGN. VERT. <b>SX</b>					•		
	473385 W	GR. ALBERO POSTERIORE MAGN. VERT. <b>DX</b>					•		
3	473372 G	GR. ALBERO CONTRASTO MAGN. VERT. <b>SX</b>					•		
	473386 X	GR. ALBERO CONTRASTO MAGN. VERT. <b>DX</b>					•		
4	473377 D	BOCCOLA ALBERO PRESS. MAGN. VERT. <b>DX</b>					•		
5	475935 P	SUPPORTO PRESSORI MAGN. VERT. <b>SX</b>					•		
	473382 T	SUPPORTO PRESSORI MAGN. VERT. <b>DX</b>					•		
6	473298 F	BARRA DI TORSIONE - GIALLA					•		
7	473378 N	BARRA DI TORSIONE - VERDE					•		
8	473356 G	BOCCOLA PRESSORE MAGN. VERT. <b>DX</b>					•		
9	473393 W	MANOVELLA					•	•	•
10	473394 X	MOLLA A SPILLO					•	•	•
11	473390 F	GRUPPO MYLAR					•		
12	473392 V	STUD ALBERO BANDELLA					•	•	•
13	473379 P	BARRA DI TORSIONE - BIANCA					•		
14	XYAA5190	BARRA DI TORSIONE - GRIGIA					•		
15	473370 J	PULEGGIA PER MAGN. VERT.					•		
16	473353 D	CINGHIA DENTATA Z=55					•		
17	475009 B	BOCCOLA PRESSORE MAGN. VERT. <b>SX</b>					•		
18	473355 F	SUPPORTO ALBERO					•		
19	473348 Q	CINGHIA DENTATA Z=88					•		
20	473296 V	BARRA DI TORSIONE - BLU					•		
21	473295 U	BARRA DI TORSIONE - ROSSA					•		



# GRUPPO STRUTTURA INFERIORE SCANNER

PR2E

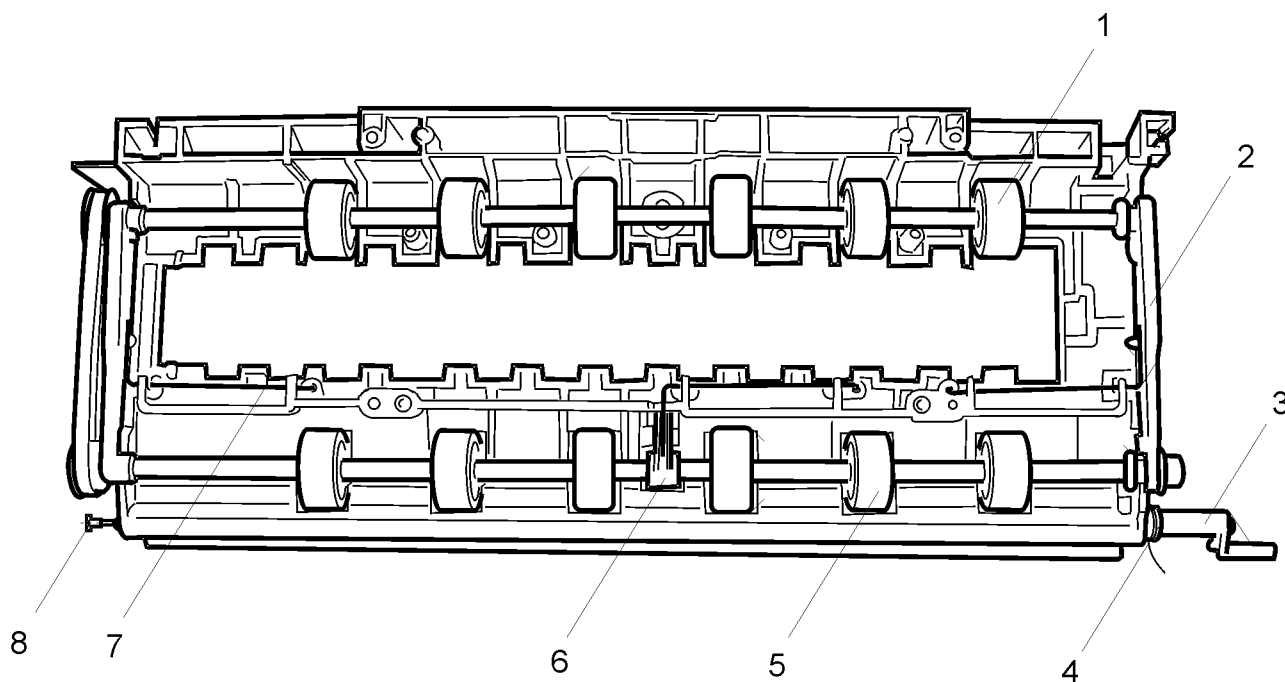
RIF.	CODICE	DESCRIZIONE	10 E	10 E PASS	12 E M.OR	12 M E MICR	13 E M.VER	10 E SC/F	10 E SC/F B
1	395103 W	GRUPPO RULLO CONTRASTO SCANNER						•	•
2	475253 B	GRUPPO ALBERI TRASCINAMENTO SCANNER						•	•
3	475249 P	SPORTELLINO DEFLETTORE SCANNER						•	•
	475248 N	SPORTELLINO DEFLETTORE SCANNER MICR						•	•
4	XYAA5506	CONSOLE SCANNER						•	•



# GRUPPO PRESSORI POSTERIORI SCANNER

PR2E

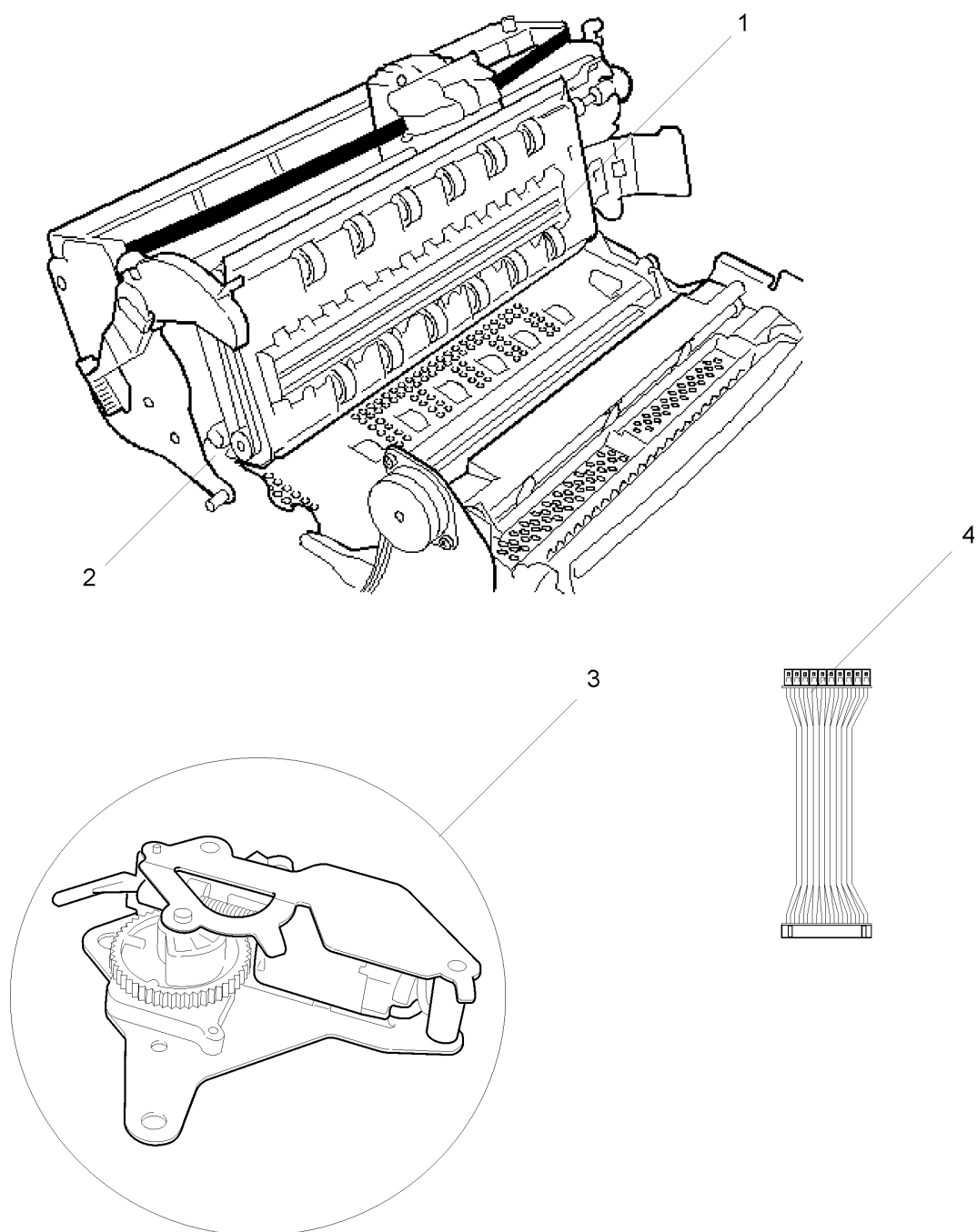
RIF.	CODICE	DESCRIZIONE	10 E	10 E PASS	12 E M.OR	12 M E MICR	13 E M.VER	10 E SC/F	10 E SC/F B
1	475114 Q	GRUPPO RULLINI PRESSORI POSTERIORI						•	•
2	XYAA4897	SUPPORTO PRESSORI						•	•
3	473393 W	MANOVELLA						•	•
4	473394 X	MOLLA A SPILLO						•	•
5	475116 J	GRUPPO RULLINI ANTERIORI						•	•
6	475122 Q	CONTRASTO ALBERO RULLINI ANTERIORE						•	•
7	473173 Z	MOLLA TORSIONE						•	•
8	473392 V	STUD ALBERO BANDELLA						•	•



# GRUPPO SCANNER

PR2E

RIF.	CODICE	DESCRIZIONE	10 E	10 E PASS	12 E M.OR	12 M E MICR	13 E M.VER	10 E SC/F	10 E SC/F B
1	XYAA5095	GRUPPO SCANNER FRONT						•	
	XYAA5151	GRUPPO SCANNER BACK							•
2	475127 M	GRUPPO MOVIMENTO SCANNER						•	•
3	XYAA6358	GRUPPO ENCODER SCANNER						•	•
4	XYAA5259	CAVO CONNESSIONE SCANNER FRONT						•	
	XYAA5260	CAVO CONNESSIONE SCANNER BACK							•



## INDICE GENERALE DEI CODICI

Codice	Pag.	Codice	Pag.	Codice	Pag.	Codice	Pag.
( * ) B6862	14	473091 K	10	473320 G	16	474996 L	12
( * ) B6877	14	473123 P	12	473330 A	17	474999 X	12
128589 Z	14	473127 K	12	473346 E	19	475009 B	20
150370 S	19	473131 P	12	473348 Q	20	475114 Q	22
395038 X	7	473135 K	12	473353 D	20	475122 Q	22
395047 Y	17	473137 M	12	473355 F	20	475127 M	23
395055 Y	7	473138 W	12	473356 G	20	475248 N	21
395060 H	12	473139 X	12	473364 G	20	475249 P	21
395079 G	11	473141 Z	12	473366 A	20	475253 B	21
395103 W	21	473150 E	12	473370 J	20	475601 H	12
395116 S	8	473151 T	12	473372 G	20	475871 X	8
395133 K	12	473156 Y	12	473376 C	19	475932 L	20
395143 V	12	473158 A	12	473377 D	20	475935 P	20
395152 W	8	473166 S	11	473378 N	20	710682 H	17
395153 X	8	473167 T	11	473379 P	20	710769 X	12
471244 E	12	473171 X	11	473382 T	20	751171 D	8
471501 Z	17	473172 Y	11	473385 W	20	751272 J	12
471514 M	17	473173 Z	11	473386 X	20	752610 J	5
473012 K	8	473174 S	8	473390 F	20	759410 R	5
473018 Z	7	473175 T	10	473392 V	20	759413 G	8
473020 X	8	473175 T	11	473392 V	22	XYAA0209	18
473020 X	19	473180 V	12	473393 W	20	XYAA1264	12
473028 T	7	473182 K	12	473393 W	22	XYAA1885	14
473034 R	6	473191 L	10	473394 X	20	XYAA2037	14
473047 W	8	473192 M	10	473394 X	22	XYAA2102	15
473048 F	8	473197 J	10	473395 Y	19	XYAA2106	15
473049 G	8	473244 G	11	473396 Z	19	XYAA2109	15
473050 D	8	473248 L	11	473479 C	8	XYAA3394	8
473051 S	8	473265 D	10	473486 L	17	XYAA3400	6
473052 T	8	473285 S	17	473487 M	17	XYAA3406	5
473056 X	8	473295 U	20	473498 Y	12	XYAA3407	5
473058 H	8	473296 V	20	473499 Z	16	XYAA3409	5
473069 C	7	473298 F	20	473540 D	5	XYAA3411	5
473071 W	8	473302 B	17	474400 B	12	XYAA3415	5
473072 X	7	473303 C	17	474943 W	10	XYAA3017	19
473073 Y	7	473308 R	17	474952 X	17	XYAA3419	7
473074 Z	7	473309 J	17	474953 Y	10	XYAA3419	17
473075 S	7	473311 T	17	474954 Z	10	XYAA3575	6
473077 U	10	473314 W	16	474967 W	18	XYAA3703	16
473083 K	10	473315 X	16	474990 S	18	XYAA4897	22
473085 M	10	473317 Z	16	474992 Q	17	XYAA5095	23



## INDICE GENERALE DEI CODICI

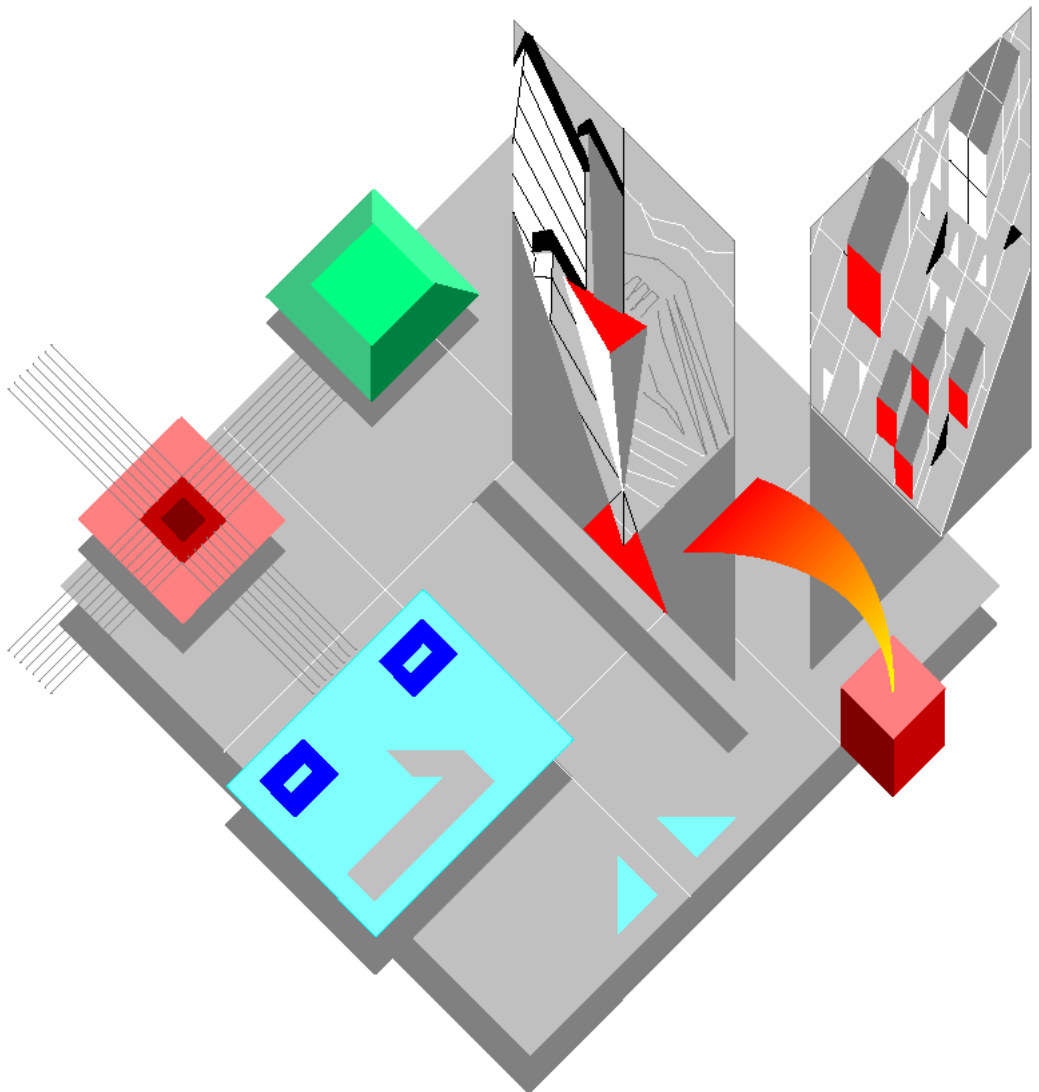
Codice	Pag.	Codice	Pag.	Codice	Pag.	Codice	Pag.
XYAA5151	23						
XYAA5190	20						
XYAA5259	23						
XYAA5260	23						
XYAA5322	19						
XYAA5506	21						
XYAA5699	14						
XYAA5795	6						
XYAA5796	6						
XYAA6261	17						
XYAA6262	17						
XYAA6332	7						
XYAA6358	23						
XYAA6388	14						
XYAA6389	14						
XYAA7928	8						
XYAA9394	12						

PRINTER

# PR2E

SPARE PARTS CATALOGUE

Code **XYAA2112-03**



**PUBLICATION ISSUED BY :**

**Olivetti S.p.A.**  
Via Camillo Olivetti , 8  
10011 Agliè ( Italy )

**Copyright © 2006, by Olivetti**  
**All rights reserved**

**Printed in Italy by :**

---

**IMPORTANT**

THIS PUBLICATION, CREATED BY THE OLIVETTI S.p.A ( SPARE PARTS DEPARTMENT )  
REPRESENTES THE ONLY REFERENCE DOCUMENTATION FOR ORDERING SPARE PARTS.

---

**UPDATING STATUS**

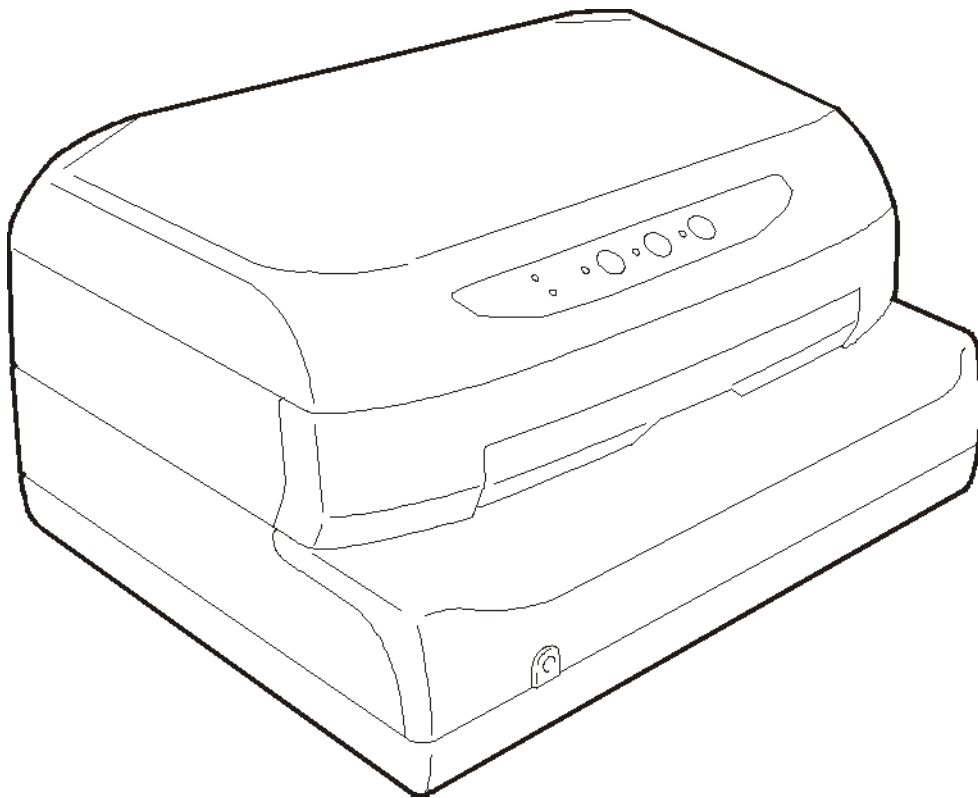
<b>DATE</b>	<b>CODE</b>
<b>03/2003</b>	<b>XYAA2112</b>
<b>03/2004</b>	<b>XYAA2112-01</b>
<b>01/2006</b>	<b>XYAA2112-02</b>
<b>03/2006</b>	<b>XYAA2112-03</b>

# INDEX

OVERVIEW .....	3
MODELS .....	4
CASING .....	5
BASE UNIT AND POWER SUPPLY .....	6
LOWER SECTION GROUP 1 .....	7
LOWER SECTION GROUP 2 .....	8-9
LOWER SECTION GROUP 3 .....	10
REAR PRESSURE UNIT .....	11
PRINTING UNIT .....	12-13
ELECTRONIC BOARDS .....	14
DETAILS.....	15
LOWER SECTION WITH HORIZONTAL MAGNETIC READER DEVICE .....	16
HORIZONTAL MAGNETIC DEVICE WITH MICR.....	17
LOWER SECTION WITH PASSPORT .....	18
LOWER SECTION WITH VERTICAL MAGNETIC READER DEVICE .....	19
REAR PRESSURE UNIT VERTICAL MAGNETIC READER DEVICE .....	20
LOWER SECTION WITH SCANNER .....	21
REAR PRESSURE UNIT SCANNER .....	22
SCANNER UNIT .....	23

<b>GENERAL INDEX CODES</b>	<b>24</b>
----------------------------	-----------





# MODELS

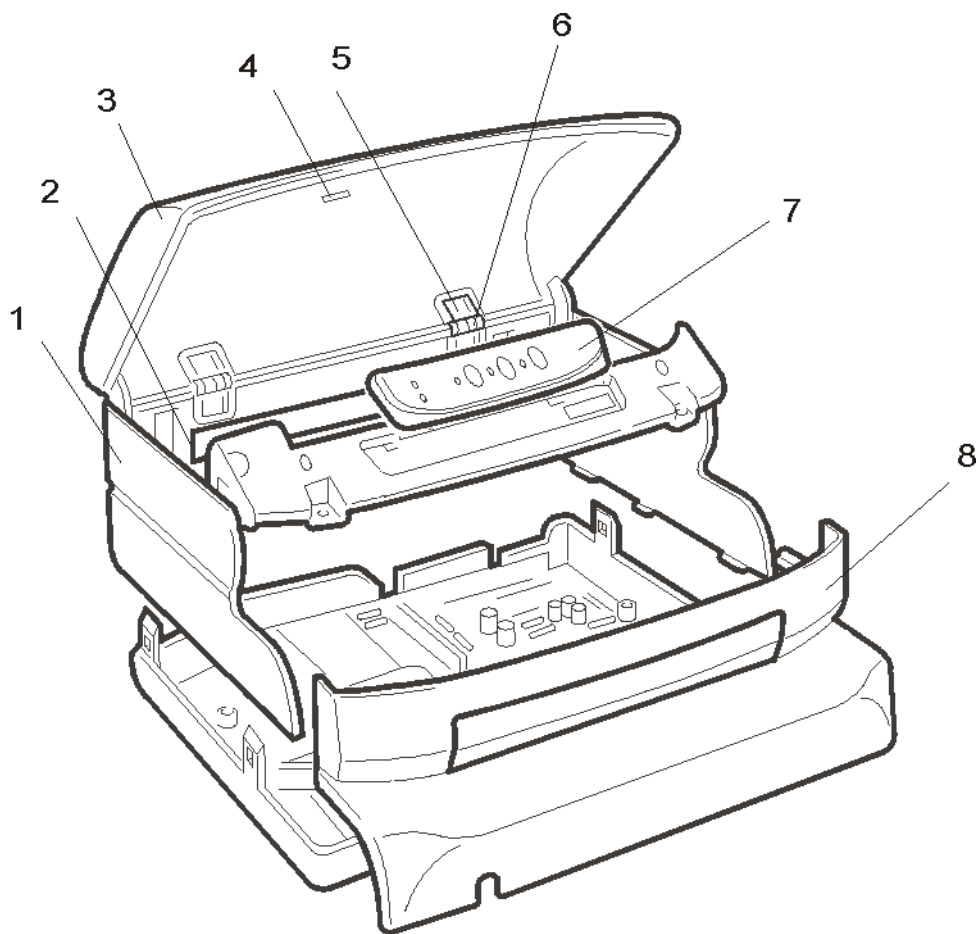
PR2E

<b>MODEL</b>	<b>DESCRIPTION</b>
PR2 S <b>10 E</b>	BASE MODEL
PR2 S <b>10 E PASS</b>	PASSPORT MODEL
PR2 S <b>12 E</b>	HORIZONTAL MAGNETIC DEVICE MODEL
PR2 S <b>12 M E</b>	MICR MODEL
PR2 S <b>13 E</b>	VERTICAL MAGNETIC DEVICE MODEL
PR2 P <b>10 E SC/F</b>	SCANNER FRONT MODEL
PR2 U <b>10 E SC/F B</b>	SCANNER FRONT / BACK MODEL

# CASING

PR2E

REF.	CODE	DESCRIPTION	10 E	10 E PASS	12 E M.OR	12 M E MICR	13 E M.VER	10 E SC/F	10 E SC/F B
1	XYAA3415	BODY ASSEMBLY	•	•	•	•	•	•	•
2	XYAA3407	REAR PROTECTION	•	•	•	•	•	•	•
3	XYAA3411	UPPER COVER	•	•	•	•	•	•	•
4	752610 J	COVER MAGNET	•	•	•	•	•	•	•
5	473540 D	HINGE	•	•	•	•	•	•	•
6	759410 R	HINGE FOR PIN	•	•	•	•	•	•	•
7	XYAA3406	CONSOLE	•	•	•	•	•		
8	XYAA3409	FRONT SECTION ASSEMBLY	•	•	•	•	•	•	•

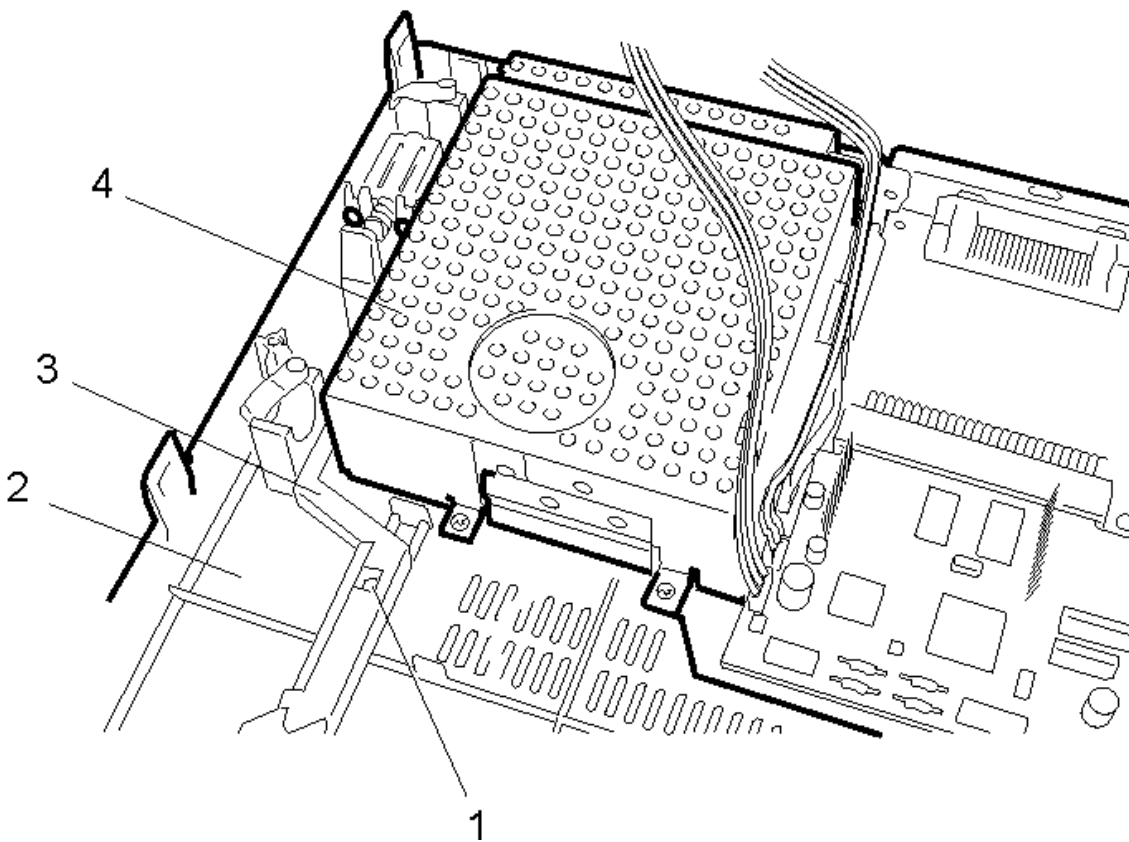




# BASE UNIT AND POWER SUPPLY

PR2E

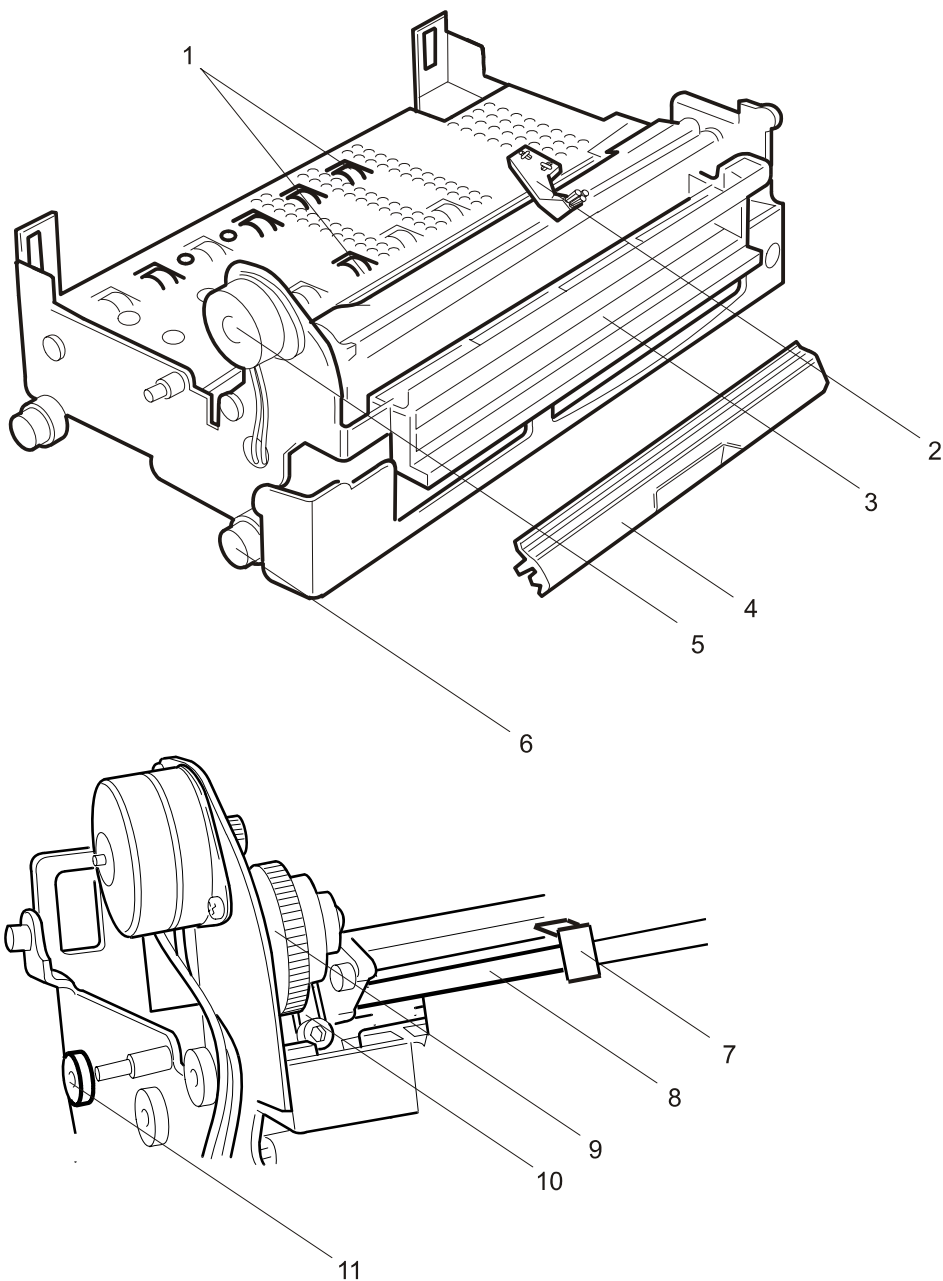
REF.	CODE	DESCRIPTION	10 E	10 E PASS	12 E M.OR	12 M E MICR	13 E M.VER	10 E SC/F	10 E SC/F B
1	473034 R	SLIDING SWITCH SPRING	•	•	•	•	•	•	•
2	XYAA3400	BASE UNIT WITH SLIDE-PROOF PAD	•	•	•	•	•	•	•
3	XYAA3575	SLIDING SWITCH	•	•	•	•	•	•	•
4	XYAA5795 XYAA5796	220V POWER SUPPLY UNIT 115V POWER SUPPLY UNIT	•	•	•	•	•	•	•



# LOWER SECTION GROUP 1

PR2E

REF	CODE	DESCRIPTION	10 E	10 E PASS	12 E M.OR	12 M E MICR	13 E M.VER	10 E SC/F	10 E SC/F B
1	473028 T	FEED SHAFT GROUP	•	•	•	•			
2	395055 Y	BRUSH	•	•	•	•	•	•	•
3	XYAA6332	OPTICAL FIBER GROUP RICO	•	•			•	•	•
4	XYAA3419	DEFLECTOR FLAP	•		•		•		
5	473069 C	MOTOR SERVICE UNIT	•	•	•	•	•	•	•
6	395038 X	DUMPING RUBBER FRAME	•	•	•	•	•	•	•
7	473075 S	PRESSURE SPRING HOLDER	•	•	•	•	•	•	•
8	473073 Y	PRESSURE SUPPORT ARM	•	•	•	•	•	•	•
9	473072 X	SERVICE CAM	•	•	•	•	•	•	•
10	473074 Z	LINK FOR MECHANICAL PRESSURE	•	•	•	•	•	•	•
11	473018 Z	LEFT GUIDE BUSH	•	•	•	•	•	•	•



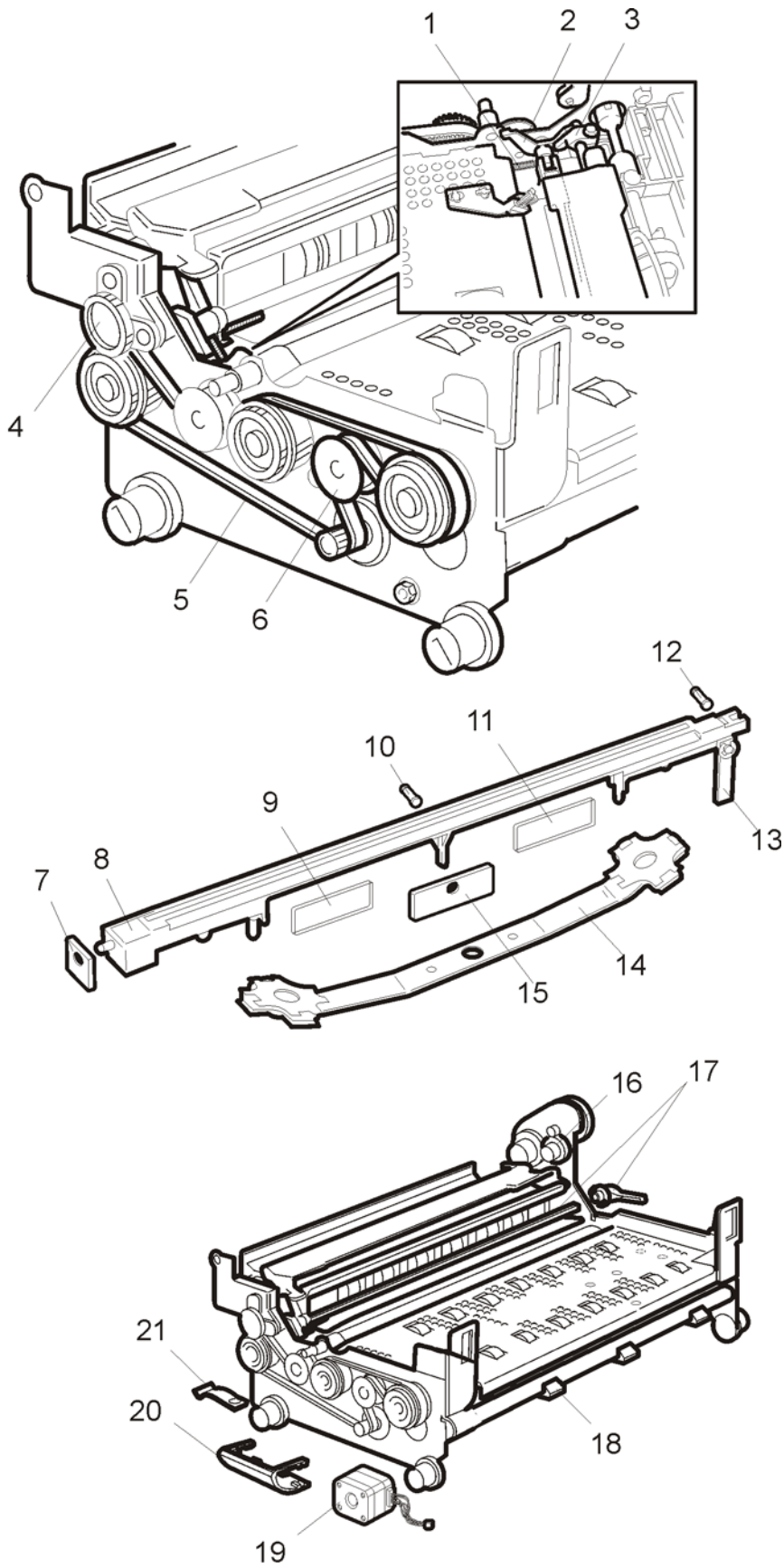
## LOWER SECTION GROUP 2

PR2E

REF	CODE	DESCRIPTION	10 E	10 E PASS	12 E M.OR	12 M E MICR	13 E M.VER	10 E SC/F	10 E SC/F B
1	473052 T	FLAP UNIT SPRING	•	•	•	•	•	•	•
2	473050 D	FLAP EQUALIZING DRIVE UNIT	•	•	•	•	•	•	•
3	473051 S	FLAP CONTROL MECHANISM	•	•	•	•	•	•	•
4	473174 S	CONTROL ROLLER PRESSURE	•	•	•	•	•	•	•
5	751171 D	DOCUMENT FEED BELT. (Z=210)	•	•	•	•	•	•	•
6	473479 C	BELT TENSION PULLEY	•	•	•	•	•	•	•
7	473049 G	LEFT BALLAST	•	•	•	•	•	•	•
8	395116 S	PRINTER CROSSFLIGHT UNIT	•		•	•	•	•	•
9	395153 X	REAR PRINTING BAR DUMPENER	•	•	•	•	•	•	•
10	473056 X	CENTRAL BALLAST PIN	•	•	•	•	•	•	•
11	395152 W	FRONT PRINTING BAR DUMPENER	•	•	•	•	•	•	•
12	473047 W	RIGHT BALLAST PIN	•	•	•	•	•	•	•
13	473048 F	RIGHT BALLAST	•	•	•	•	•	•	•
14	475871 X	SPRING DUMPER UNIT	•	•	•	•	•	•	•
15	473058 H	CENTRAL BALLAST	•	•	•	•	•	•	•
16	473071 W	INTERMEDIATE GEAR	•	•	•	•	•	•	•
17	XYAA7928	PAPER PRESSURE FLAP & OPENING LEVER	•	•	•	•		•	•
18	XYAA3394	ROLLER SCREEN	•	•	•	•	•	•	•
19	473020 X	LINE SPACING MOTOR UNIT	•	•	•	•		•	•
20	473012 K	FLAT CABLE GUIDE BRACKET	•	•	•	•	•	•	•
21	759413 G	MECHANICAL UNIT SECURING BRACKET	•	•	•	•	•	•	•

LOWER SECTION GROUP 2

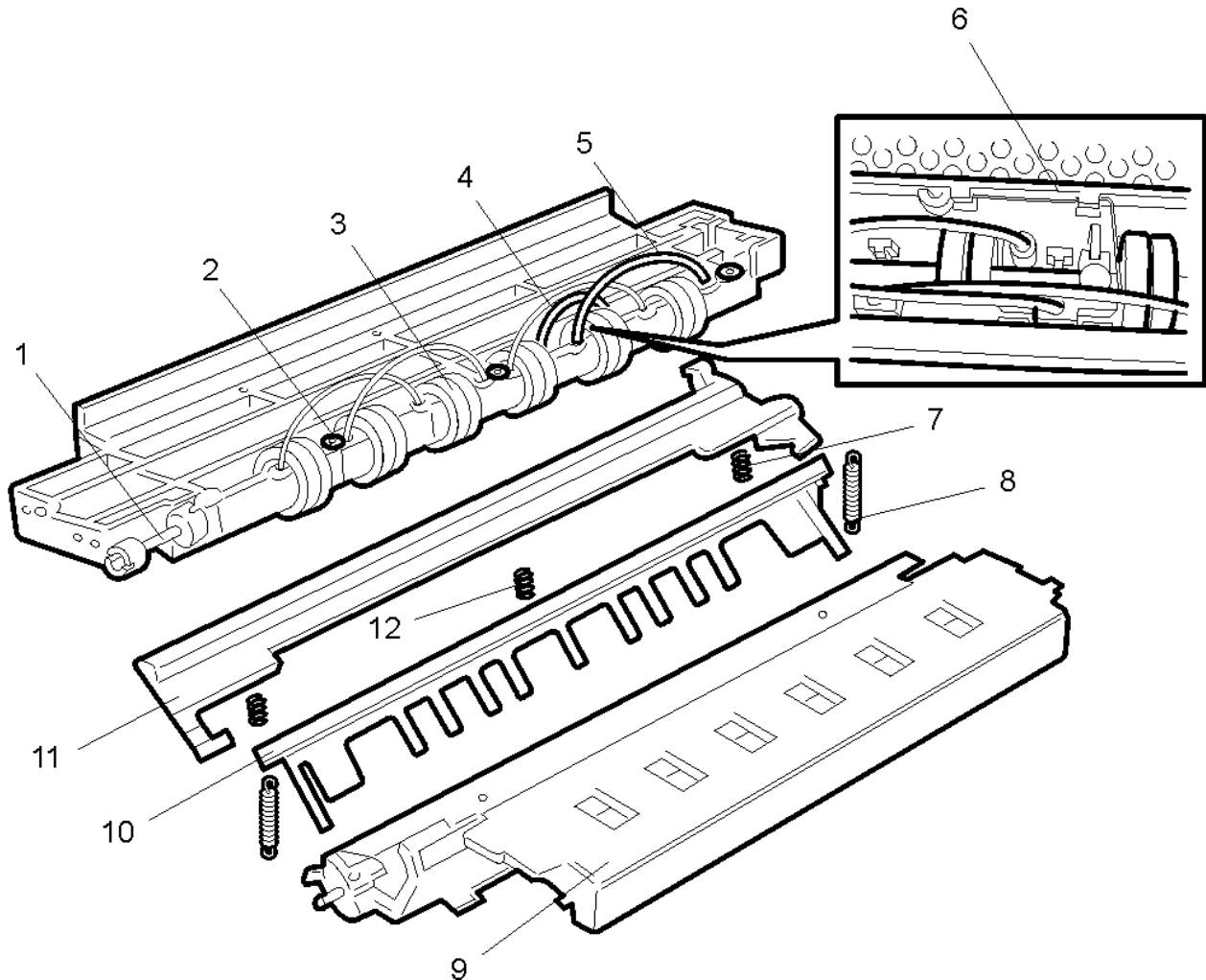
PR2E



# LOWER SECTION GROUP 3

PR2E

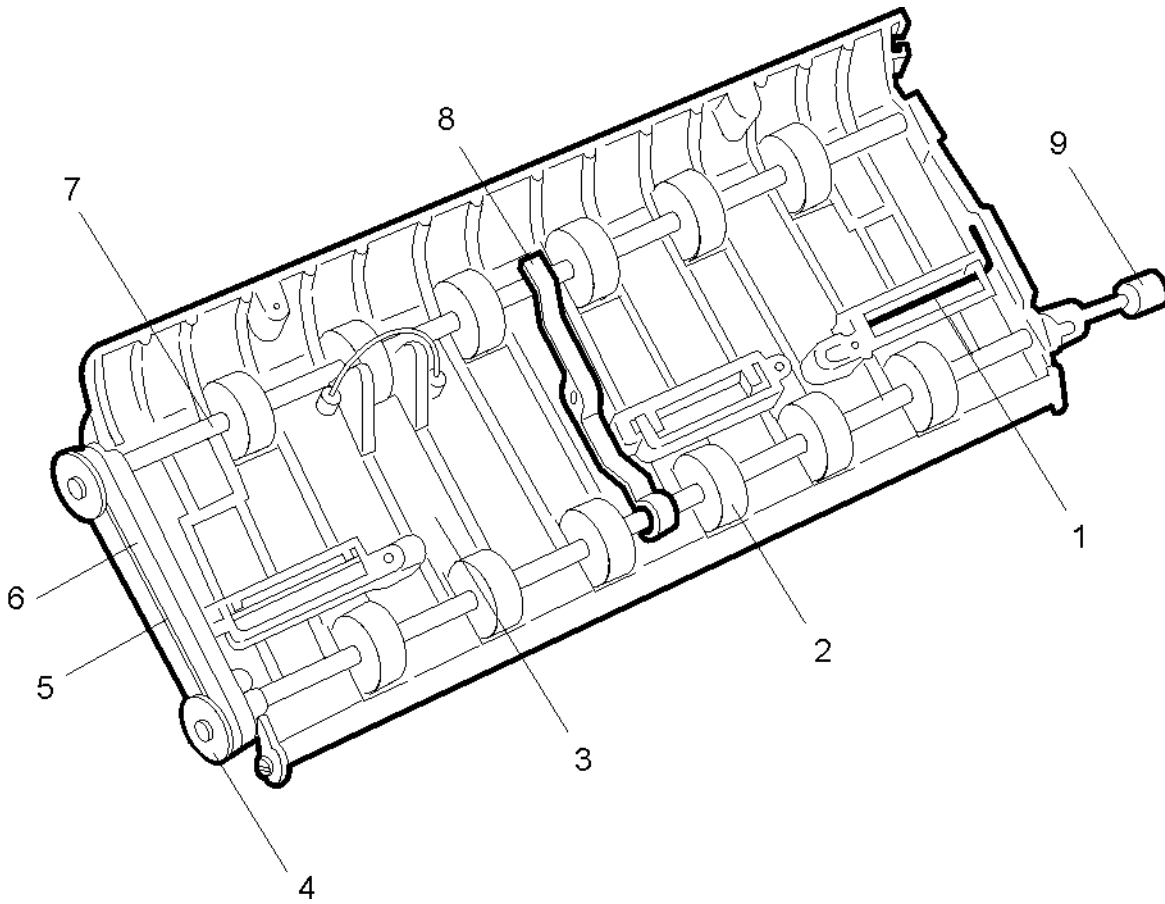
REF	CODE	DESCRIPTION	10 E	10 E PASS	12 E M.OR	12 M E MICR	13 E M.VER	10 E SC/F	10 E SC/F B
1	473175 T	JOINT	•	•	•	•	•	•	•
2	474953 Y	GUIDE BUSH	•	•	•	•	•	•	•
3	474943 W	ALIGNMENT ROLLERS UNIT			•	•			
4	473192 M	OPTICAL FIBER L=80			•	•			
5	473191 L	OPTICAL FIBER L=100			•	•			
6	473091 K	ALIGNMENT ROLLER SPRING			•	•			
7	473083 K	PRESSURE SPRING	•	•	•	•	•	•	•
8	473265 D	COMB SPRING	•	•	•	•	•	•	•
9	473085 M	FRONT PHOTO SUPPORT	•	•	•	•	•	•	•
10	473077 U	COMB	•	•	•	•	•	•	•
11	474954 Z	SUPPORT COMB	•	•	•	•	•	•	•
12	473197 J	BLACK PRESSURE SPRING	•	•	•	•	•	•	•



# REAR PRESSURE UNIT

PR2E

REF	CODE	DESCRIPTION	10 E	10 E PASS	12 E M.OR	12 M E MICR	13 E M.VER	10 E SC/F	10 E SC/F B
1	473173 Z	TORSION SPRING	•	•	•	•		•	•
2	473244 G	FRONT ROLLERS UNIT	•	•	•	•			
3	395079 G	PRESSURE SUPPORT UNITS	•	•	•	•		•	•
4	473166 S	PULLEY	•	•	•	•		•	•
5	473172 Y	BELT Z=28	•	•	•	•		•	•
6	473171 X	LEFT GUIDE BUSH	•	•	•	•		•	•
7	473248 L	REAR PRESSURE ROLLERS UNIT	•	•	•	•			
8	473167 T	CENTRAL GUIDE BUSH	•	•	•	•			
9	473175 T	JOINT	•	•	•	•	•	•	•



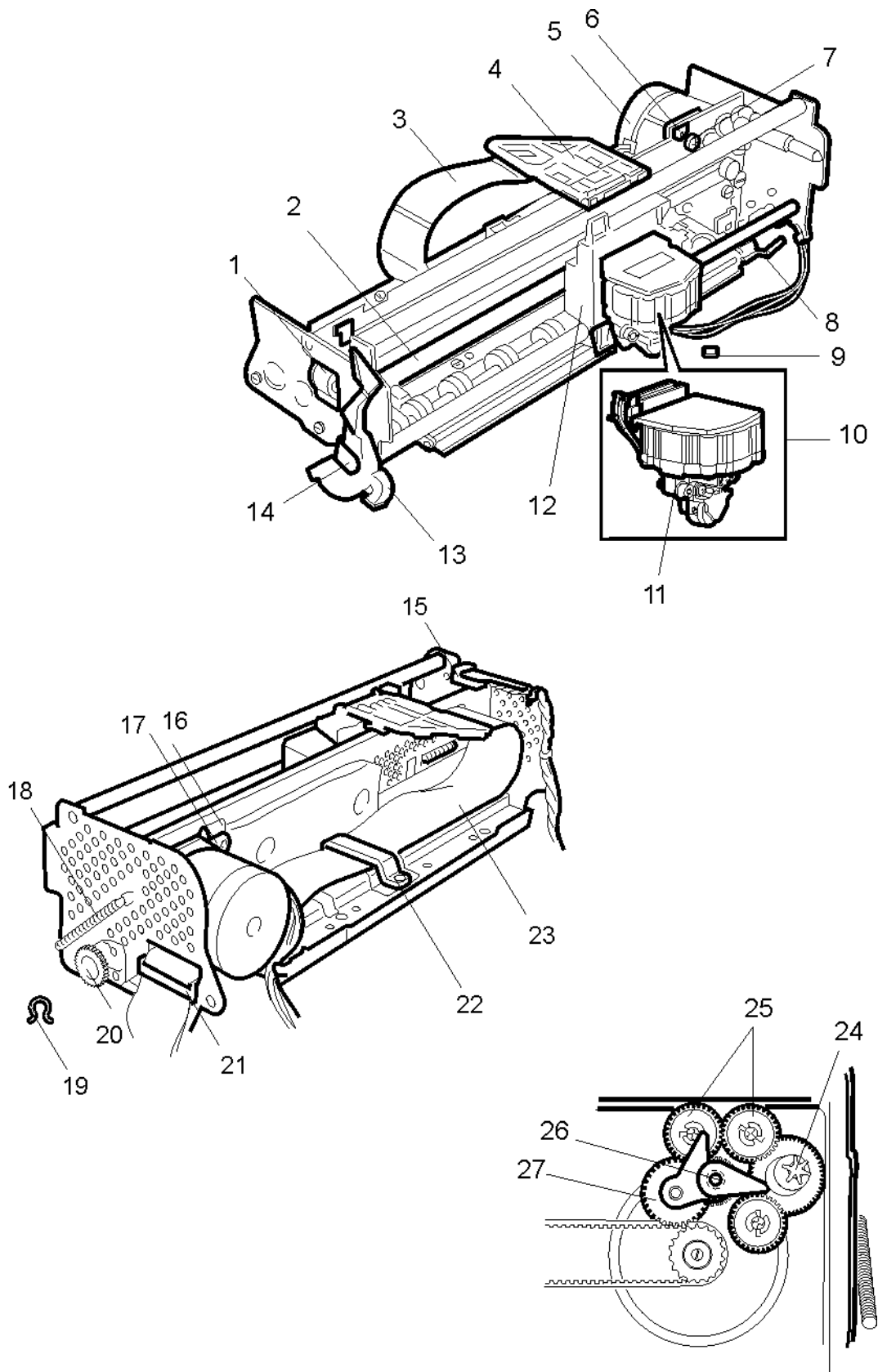
## PRINTING UNIT

## PR2E

REF	CODE	DESCRIPTION	10 E	10 E PASS	12 E M.OR	12 M E MICR	13 E M.VER	10 E SC/F	10 E SC/F B
1	751272 J	SNUB PULLEY	•	•	•	•	•	•	•
2	473123 P	CARRIAGE MOVEMENT BELT	•	•	•	•	•	•	•
3	473135 K	PRINT HEAD FLAT CABLE SCREEN	•	•	•	•	•	•	•
4	473137 M	FLAT CABLE SUPPORT	•	•	•	•	•	•	•
5	475601 H	TRANSPORT MOTOR UNIT	•	•	•	•	•	•	•
6	473141 Z	TRANSPORT MOTOR DUMPER	•	•	•	•	•	•	•
7	471244 E	MOTOR ANCHORAGE STUD	•	•	•	•	•	•	•
8	473127 K	CARRIAGE SUPPORT SHAFT	•	•	•	•	•	•	•
9	473150 E	CARRIAGE LUBRIFICATING PAD	•	•	•	•	•	•	•
10	XYAA1264	PRINT HEAD UNIT	•	•	•	•	•	•	•
11	474996 L	SENSOR HEAD PHOTO UNIT	•	•	•	•	•	•	•
12	395133 K	HEAD SUPPORT CARRIAGE	•	•	•	•	•	•	•
13	474999 X	OPENING LEVER FOR UPPER STRUCTURE	•	•	•	•	•	•	•
14	473158 A	LEVER GROUND CONNECTION BRACKET	•	•	•	•	•	•	•
15	395060 H	CARRIAGE RESET PHOTO	•	•	•	•	•	•	•
16	473156 Y	GROUND CONNECTION BRACKET	•	•	•	•	•	•	•
17	710769 X	TRANSPORT MOTOR ANCHORAGE PLATE	•	•	•	•	•	•	•
18	473151 T	LOCKING LEVER SPRING	•	•	•	•	•	•	•
19	473182 K	BUSH UNIT LEAF SPRING	•	•	•	•	•	•	•
20	473180 V	PRESSURE ROLLER DRIVE UNIT	•	•	•	•	•	•	•
21	473139 X	RIGHT FLAT CABLE GUIDE	•	•	•	•	•	•	•
22	473138 W	FLAT CABLE ANCHORAGE	•	•	•	•	•	•	•
23	474400 B	PRINT HEAD FLAT CABLE	•	•	•	•	•	•	•
24	395143 V	LANCE	•	•	•	•	•	•	•
25	XYAA9394	RIBBON FEED WHEEL	•	•	•	•	•	•	•
26	473498 Y	EXCHANGER	•	•	•	•	•	•	•
27	473131 P	RIBBON DRIVE GEAR	•	•	•	•	•	•	•

PRINTING UNIT

PR2E



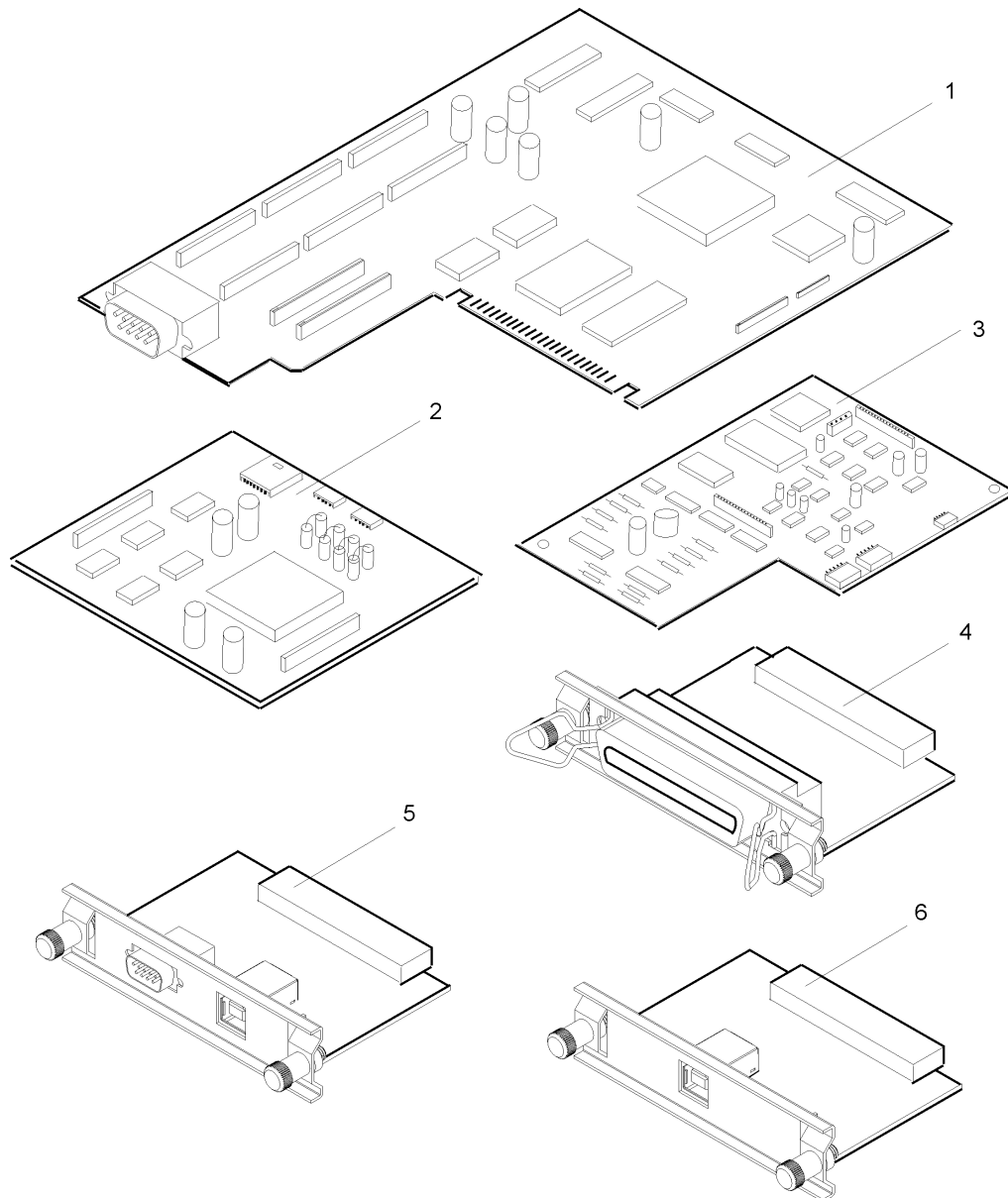


# ELECTRONIC BOARDS

# PR2E

REF	CODE	DESCRIPTION	10 E	10 E PASS	12 E M.OR	12 M E MICR	13 E M.VER	10 E SC/F	10 E SC/F B
1	128589 Z	SERIAL MAIN BOARD – BAPR2E	•	•	•	•	•	•	•
2	XYAA1885	HORIZONTAL MAGNETIC DEVICE BOARD			•				
	XYAA2037	VERTICAL MAGN. DEVICE BOARD <b>LEFT-RIGHT</b>					•		
3	XYAA5699	MICR PR2E BOARD				•			
4	( *) B6862	<b>PRM45</b> – CENTRONICS BOARD	•	•	•	•	•	•	•
	XYAA6388	SCANNER CENTRONICS PR2E BOARD						•	•
5	( *) B6877	<b>PRM40</b> - USB – RS232 BOARD	•	•	•	•	•	•	•
6	XYAA6389	SCANNER USB PR2E BOARD						•	•

( \* ) ORDER TO OLIVETTI TECNOST S.p.A.



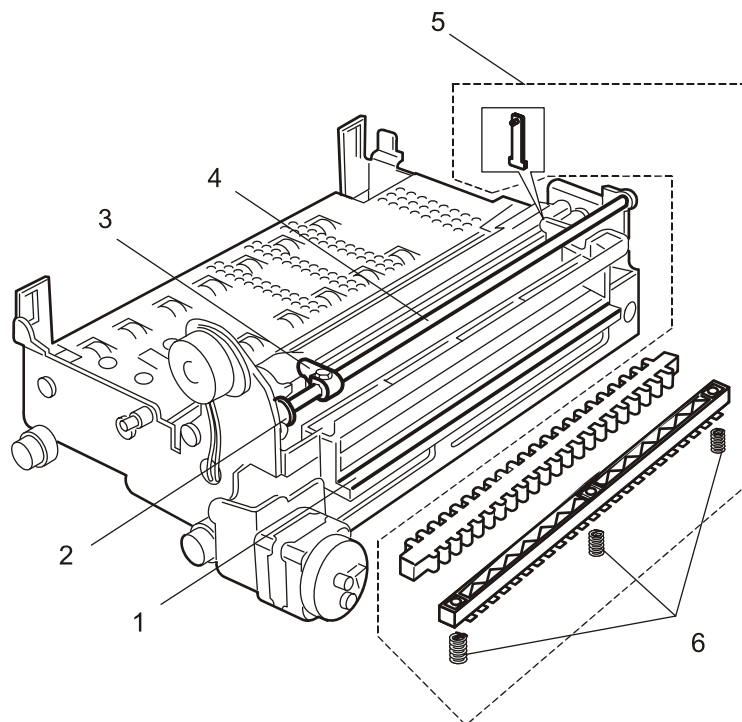
**DETAILS****PR2E**

REF	CODE	DESCRIPTION
1	XYAA2102	SCREW KIT <ul style="list-style-type: none"><li>- Nr. 10 screws M 4x6 with washer</li><li>- Nr. 10 Screwplast screws 2,9 x 9,5</li><li>- Nr. 10 Screwplast screws 2,2 x 9,5</li><li>- Nr. 10 hexagon head cap screw tap screws 2,9 x 16</li><li>- Nr. 10 hexagon head cap screw tap screws 2,9 x 13</li><li>- Nr. 10 Screwplast screws 6,5 x 2,9</li><li>- Nr. 10 self-locking nuts M3</li><li>- Nr. 10 hexagon columns</li><li>- Nr. 10 lock washers</li><li>- Nr. 10 screen studs</li><li>- Nr. 10 spacers</li><li>- Nr. 10 studs M3 4x1,5</li></ul>
2	XYAA2109	ELASTIC BRACKET KIT <ul style="list-style-type: none"><li>- Nr. 30 brackets 1,9</li><li>- Nr. 30 brackets 2,3</li><li>- Nr. 30 brackets 3,2</li><li>- Nr. 30 brackets 4</li><li>- Nr. 30 brackets 5</li><li>- Nr. 30 brackets 7</li><li>- Nr. 30 soundproof brackets</li></ul>
3	XYAA2106	CABLE HITCH KIT <ul style="list-style-type: none"><li>- Nr. 10 cables hitches</li><li>- Nr. 10 cables hitches</li><li>- Nr. 10 cables hitches</li><li>- Nr. 20 jumpers</li><li>- Nr. 30 soundproof studs</li><li>- Nr. 5 dumper straps</li><li>- Nr. 5 dumper straps</li></ul>

# LOWER SECTION HORIZONTAL MAGN. / MICR.

PR2E

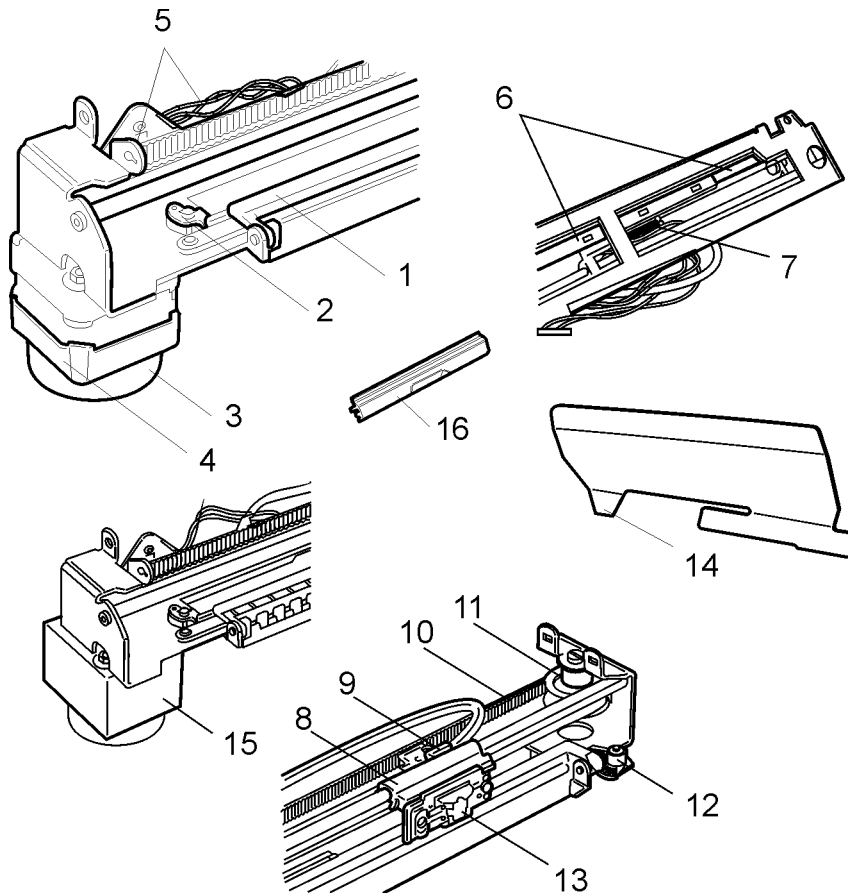
REF	CODE	DESCRIPTION	10 E	10 E PASS	12 E M.OR	12 M E MICR	13 E M.VER	10 E SC/F	10 E SC/F B
1	XYAA3703	HORIZ. MAGNETIC READ DEVICE PAPER FEED			•	•			
2	473315 X	CAM LEVER			•	•			
3	473317 Z	PRESSURE LEVER			•	•			
4	473314 W	PRESSURE SUPPORT TREE			•	•			
5	473499 Z	PRESSURE BAR UNIT			•	•			
6	473320 G	PRESSURE SPRING			•	•			



# HORIZONTAL MAGNETIC DEVICE WITH MICR

PR2E

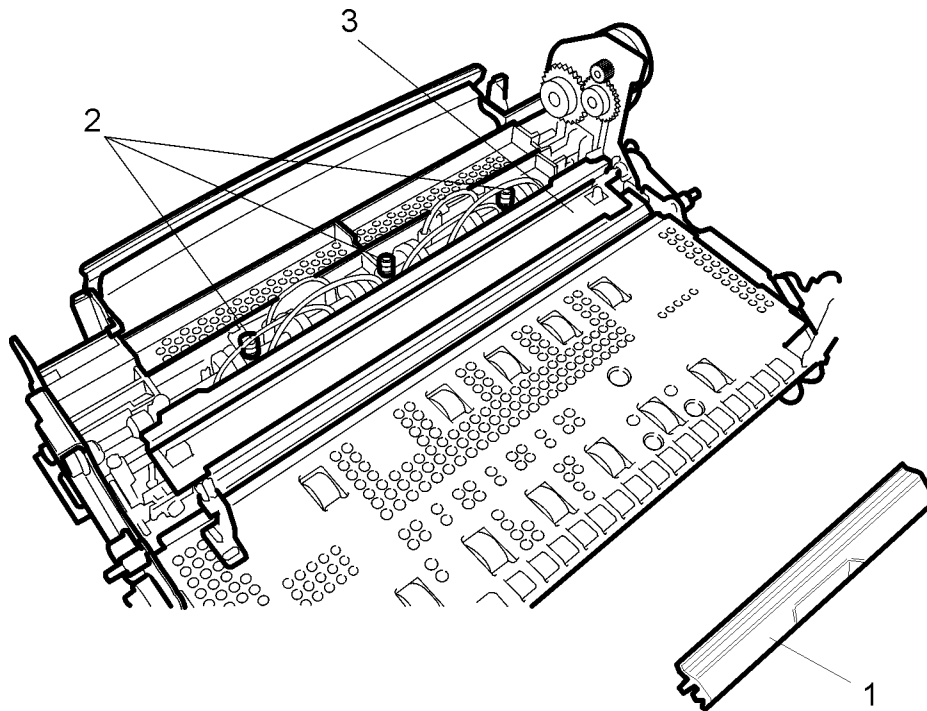
REF	CODE	DESCRIPTION	10 E	10 E PASS	12 E M.OR	12 M E MICR	13 E M.VER	10 E SC/F	10 E SC/F B
1	473486 L	COVER			•	•			
2	473285 S	FLAP OPENING JOINT			•	•			
3	710682 H	TRANSPORT MOTOR DUMPER			•	•			
4	473308 R	HORIZONTAL MAGNETIC TRANSP MOTOR UNIT			•	•			
5	473330 A	PHOTO INITIALIZING UNIT			•	•			
6	473309 J	BRACE GROUP			•	•			
7	471514 M	FLAP CLOSING SPRING			•	•			
8	474952 X	HEAD MAGNETIC CARRIAGE			•	•			
9	471501 Z	LOCKING MAGNETIC HEAD UNIT			•	•			
10	473311 T	HORIZONTAL MAGNETIC BELT ( Z=360)			•	•			
11	473302 B	SNUB PULLEY			•	•			
12	473303 C	SECTOR GEAR			•	•			
13	XYAA6261	HORIZONTAL MAGNETIC DEVICE HEAD UNIT			•				
	XYAA6262	HORIZ. MAGN. DEVICE HEAD UNIT WITH MICR				•			
14	395047 Y	MYLAR			•	•			
15	473487 M	HORIZ. MAGNETIC / MICR MOTOR SHIELD				•			
16	474992 Q	MICR DEFLECTOR FLAP				•			
	XYAA3419	HORIZ. MAGNETIC DEFLECTOR FLAP			•				



# LOWER SECTION WITH PASSPORT

PR2E

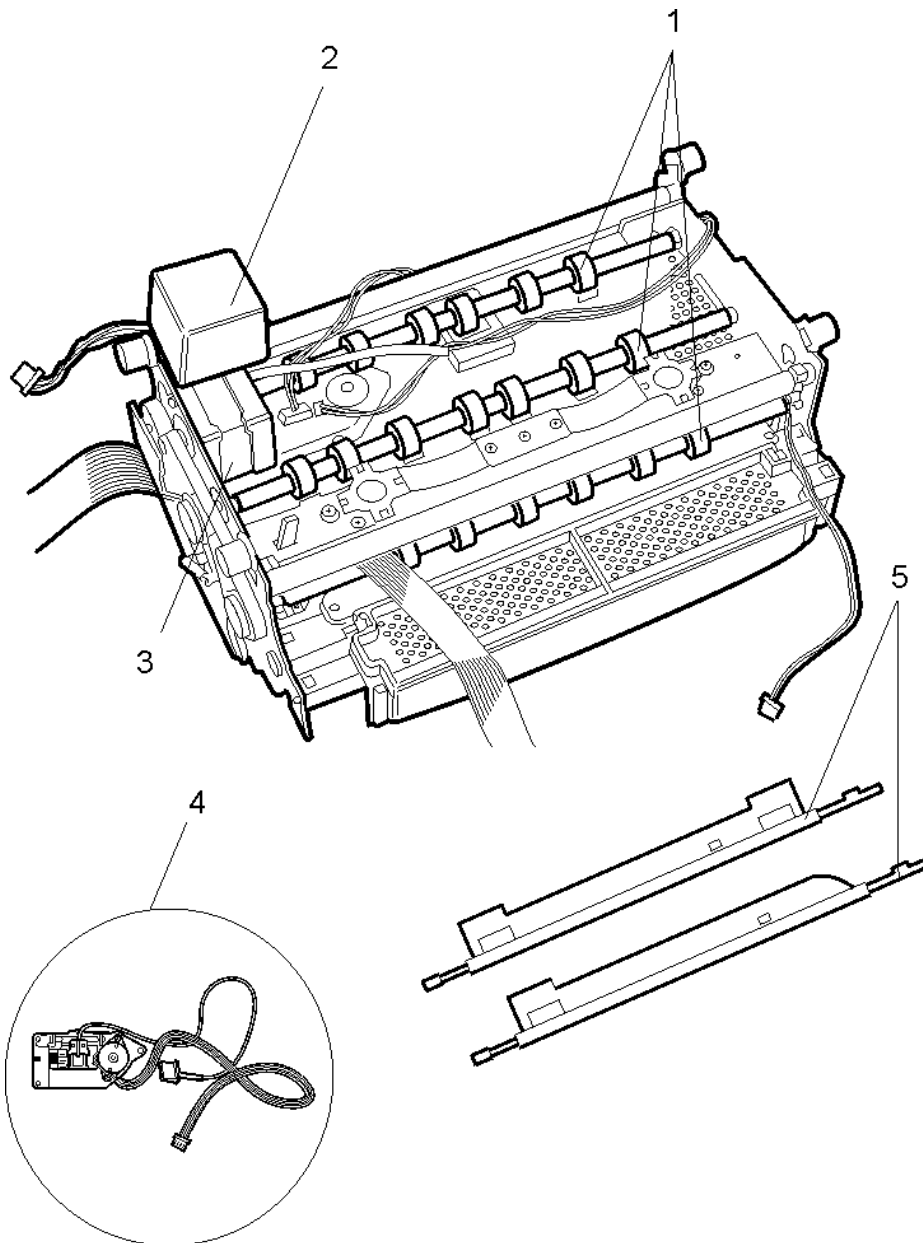
REF	CODE	DESCRIPTION	10 E	10 E PASS	12 E M.OR	12 M E MICR	13 E M.VER	10 E SC/F	10 E SC/F B
1	474990 S	FRONT FLAP COVER PASSPORT		•					
2	474967 W	YELLOW PRESSURE SPRING		•					
3	XYAA0209	PRINT BAR PASSPORT		•					



# LOWER SECTION WITH VERTICAL MAGNETIC DEVICE

PR2E

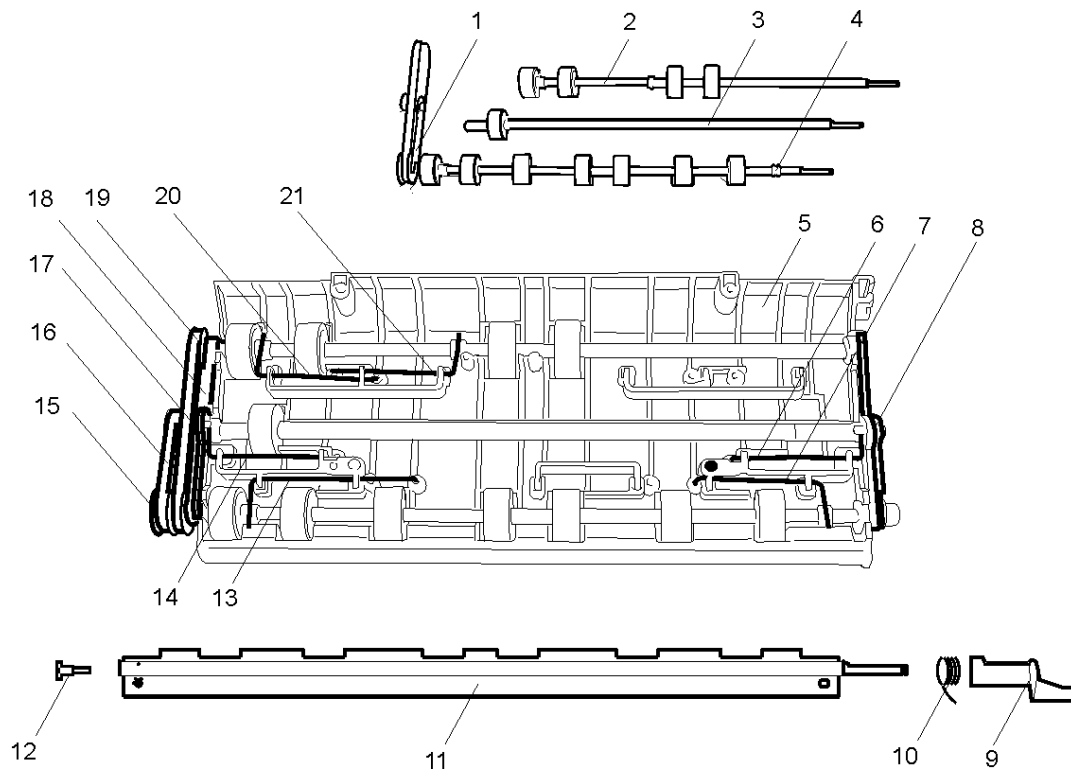
REF	CODE	DESCRIPTION	10 E	10 E PASS	12 E M.OR	12 M E MICR	13 E M.VER	10 E SC/F	10 E SC/F B
1	473376 C	LEFT VERT. MAGNETIC FEED SHAFT GROUP					•		
	473396 Z	RIGHT VERT. MAGNETIC FEED SHAFT GROUP					•		
2	473346 E	VERTICAL MAGNETIC MOTOR SHIELD					•		
3	473395 Y	RIGHT VERTICAL MAGNETIC SPACING MOTOR					•		
	473020 X	LEFT VERTICAL MAGNETIC SPACING MOTOR					•		
4	150370 S	VERTICAL MAGNETIC SUPPORT GROUP					•		
5	XYAA3017	LEFT MYLAR FLAP					•		
	XYAA5322	RIGHT MYLAR FLAP					•		



# REAR PRESSURE UNIT WITH VERTICAL MAGNETIC DEVICE

PR2E

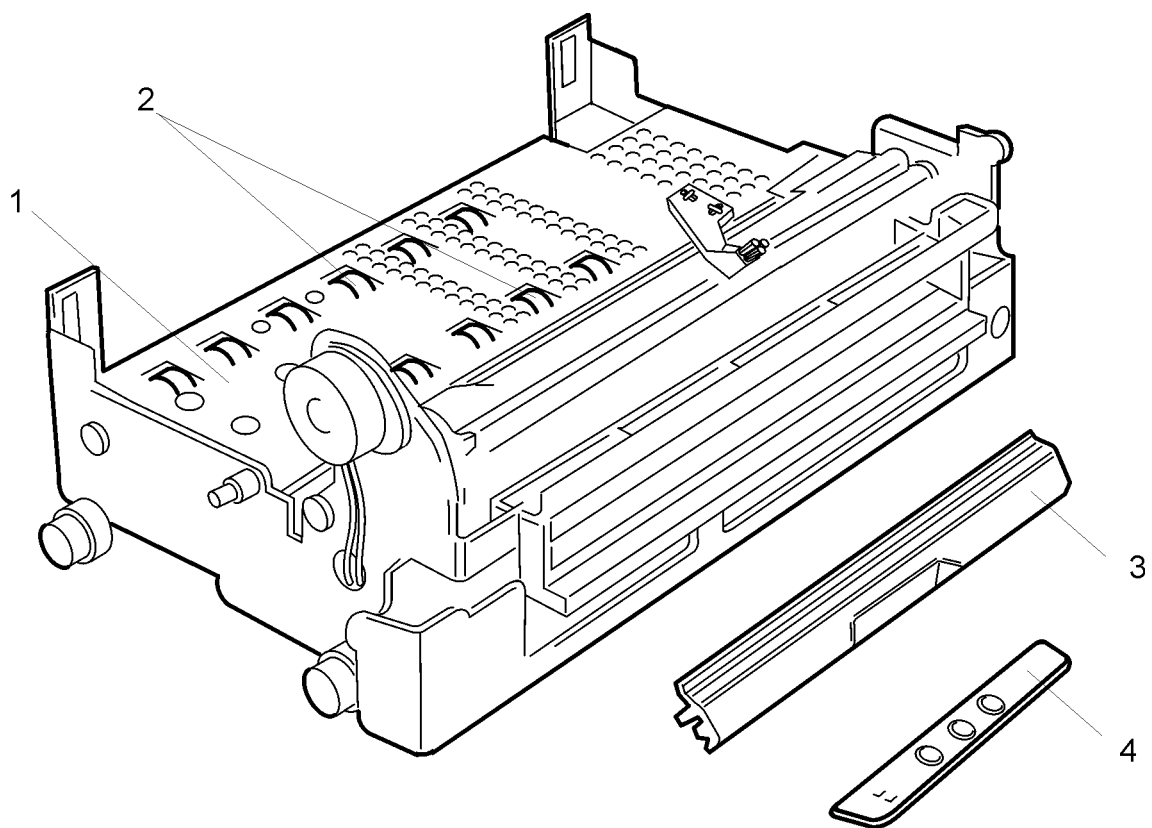
REF	CODE	DESCRIPTION	10 E	10 E PASS	12 E M.OR	12 M E MICR	13 E M.VER	10 E SC/F	10 E SC/F B
1	473364 G	LEFT VERT. MAGNETIC FRONTS ROLLER UNIT					•		
	475932 L	RIGHT VERT. MAGNETIC FRONTS ROLLER UNIT					•		
2	473366 A	LEFT VERT. MAGNETIC REAR SHAFT GROUP					•		
	473385 W	RIGHT VERT. MAGNETIC REAR SHAFT GROUP					•		
3	473372 G	LEFT VERT. MAGNETIC CONTRAST SHAFT					•		
	473386 X	RIGHT VERT. MAGNETIC CONTRAST SHAFT					•		
4	473377 D	LEFT VERTICAL MAGNETIC SHAFT BUSH					•		
5	475935 P	LEFT VERT. MAGNETIC PRESSURE SUPPORT					•		
	473382 T	RIGHT VERT. MAGNETIC PRESSURE SUPPORT					•		
6	473298 F	YELLOW – TORSION BAR					•		
7	473378 N	GREEN – TORSION BAR					•		
8	473356 G	RIGHT VERT. MAGNETIC PRESSURE BUSHING					•		
9	473393 W	VERTICAL MAGNETIC HANDLE					•	•	•
10	473394 X	VERTICAL MAGNETIC PIN SPRING					•	•	•
11	473390 F	VERTICAL MAGNETIC MYLAR GROUP					•		
12	473392 V	SHAFT STRAP STUD					•	•	•
13	473379 P	WHITE – TORSION BAR					•		
14	XYAA5190	GREY – TORSION BAR					•		
15	473370 J	VERTICAL MAGNETIC PULLEY					•		
16	473353 D	BELT TIMING Z=55					•		
17	475009 B	LEFT VERT. MAGNETIC PRESSURE BUSHING					•		
18	473355 F	SHAFT SUPPORT					•		
19	473348 Q	BELT TIMING Z=88					•		
20	473296 V	BLUE – TORSION BAR					•		
21	473295 U	RED – TORSION BAR					•		



# LOWER SECTION WITH SCANNER

PR2E

REF	CODE	DESCRIPTION	10 E	10 E PASS	12 E M.OR	12 M E MICR	13 E M.VER	10 E SC/F	10 E SC/F B
1	395103 W	SCANNER CONTRAST ROLLER GROUP						•	•
2	475253 B	FEED SHAFT GROUP SCANNER						•	•
3	475249 P	SCANNER DEFLECTOR FLAP						•	•
	475248 N	SCANNER MICR DELECTOR FLAP						•	•
4	XYAA5506	SCANNER CONSOLE						•	•

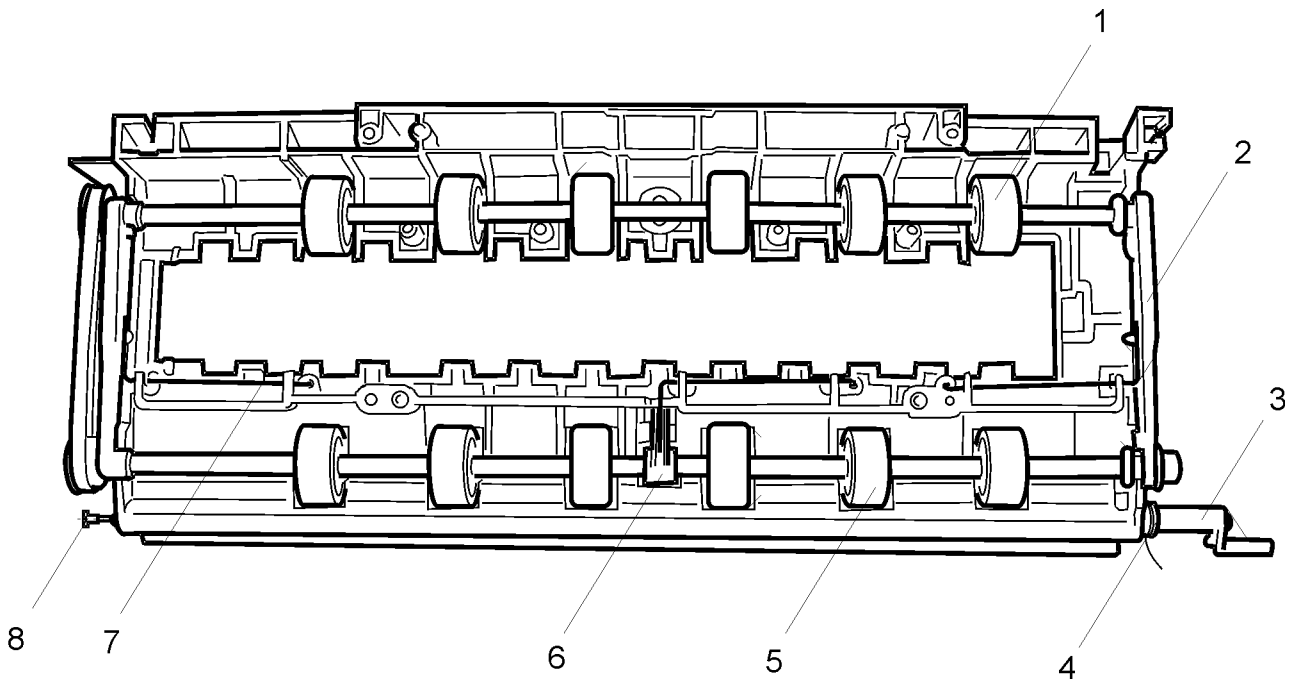




# REAR PRESSURE UNIT SCANNER

PR2E

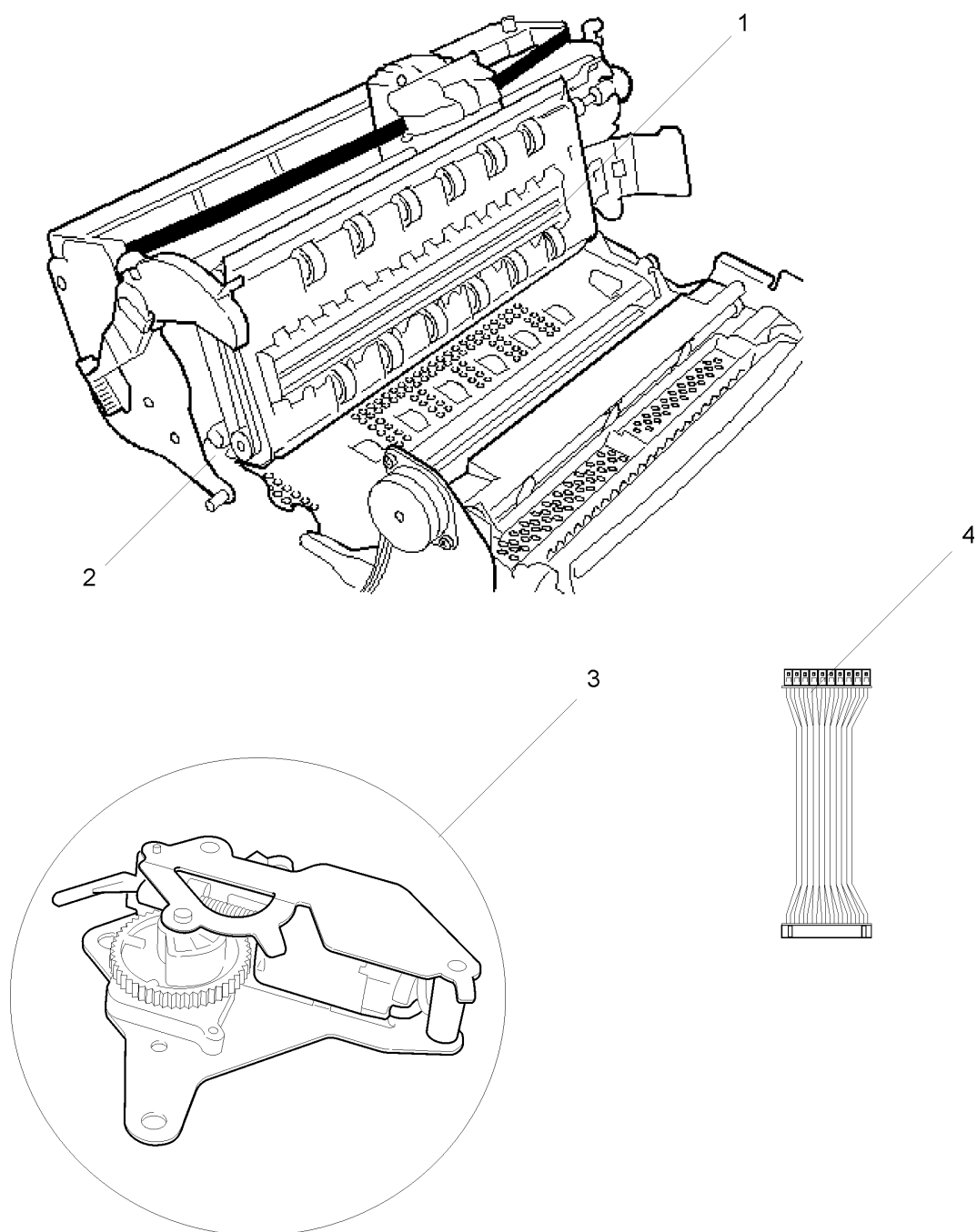
REF	CODE	DESCRIPTION	10 E	10 E PASS	12 E M.OR	12 M E MICR	13 E M.VER	10 E SC/F	10 E SC/F B
1	475114 Q	REAR PRESSURE ROLLERS UNIT						•	•
2	XYAA4897	PRESSURE UNIT SUPPORT						•	•
3	473393 W	HANDLE						•	•
4	473394 X	PIN SPRING						•	•
5	475116 J	FRONT ROLLER UNIT						•	•
6	475122 Q	FRONT ROLLERS SHAFT CONTRAST						•	•
7	473173 Z	TORSION SPRING						•	•
8	473392 V	SHAFT STRAP STUD						•	•



# SCANNER UNIT

PR2E

REF	CODE	DESCRIPTION	10 E	10 E PASS	12 E M.OR	12 M E MICR	13 E M.VER	10 E SC/F	10 E SC/F B
1	XYAA5095	SCANNER <b>FRONT</b> UNIT						•	
	XYAA5151	SCANNER <b>BACK</b> UNIT							•
2	475127 M	SCANNER MOVEMENT UNIT						•	•
3	XYAA6358	ENCODER SCANNER UNIT						•	•
4	XYAA5259	SCANNER <b>FRONT</b> CONNECTION CABLE						•	
	XYAA5260	SCANNER <b>BACK</b> CONNECTION CABLE							•



## GENERAL INDEX CODES

Code	Page	Code	Page	Code	Page	Code	Page
( * ) B6862	14	473091 K	10	473320 G	16	474996 L	12
( * ) B6877	14	473123 P	12	473330 A	17	474999 X	12
128589 Z	14	473127 K	12	473346 E	19	475009 B	20
150370 S	19	473131 P	12	473348 Q	20	475114 Q	22
395038 X	7	473135 K	12	473353 D	20	475122 Q	22
395047 Y	17	473137 M	12	473355 F	20	475127 M	23
395055 Y	7	473138 W	12	473356 G	20	475248 N	21
395060 H	12	473139 X	12	473364 G	20	475249 P	21
395079 G	11	473141 Z	12	473366 A	20	475253 B	21
395103 W	21	473150 E	12	473370 J	20	475601 H	12
395116 S	8	473151 T	12	473372 G	20	475871 X	8
395133 K	12	473156 Y	12	473376 C	19	475932 L	20
395143 V	12	473158 A	12	473377 D	20	475935 P	20
395152 W	8	473166 S	11	473378 N	20	710682 H	17
395153 X	8	473167 T	11	473379 P	20	710769 X	12
471244 E	12	473171 X	11	473382 T	20	751171 D	8
471501 Z	17	473172 Y	11	473385 W	20	751272 J	12
471514 M	17	473173 Z	11	473386 X	20	752610 J	5
473012 K	8	473174 S	8	473390 F	20	759410 R	5
473018 Z	7	473175 T	10	473392 V	20	759413 G	8
473020 X	8	473175 T	11	473392 V	22	XYAA0209	18
473020 X	19	473180 V	12	473393 W	20	XYAA1264	12
473028 T	7	473182 K	12	473393 W	22	XYAA1885	14
473034 R	6	473191 L	10	473394 X	20	XYAA2037	14
473047 W	8	473192 M	10	473394 X	22	XYAA2102	15
473048 F	8	473197 J	10	473395 Y	19	XYAA2106	15
473049 G	8	473244 G	11	473396 Z	19	XYAA2109	15
473050 D	8	473248 L	11	473479 C	8	XYAA3017	19
473051 S	8	473265 D	10	473486 L	17	XYAA3394	8
473052 T	8	473285 S	17	473487 M	17	XYAA3400	6
473056 X	8	473295 U	20	473498 Y	12	XYAA3406	5
473058 H	8	473296 V	20	473499 Z	16	XYAA3407	5
473069 C	7	473298 F	20	473540 D	5	XYAA3409	5
473071 W	8	473302 B	17	474400 B	12	XYAA3411	5
473072 X	7	473303 C	17	474943 W	10	XYAA3415	5
473073 Y	7	473308 R	17	474952 X	17	XYAA3419	7
473074 Z	7	473309 J	17	474953 Y	10	XYAA3419	17
473075 S	7	473311 T	17	474954 Z	10	XYAA3575	6
473077 U	10	473314 W	16	474967 W	18	XYAA3703	16
473083 K	10	473315 X	16	474990 S	18	XYAA4897	22
473085 M	10	473317 Z	16	474992 Q	17	XYAA5095	23

## GENERAL INDEX CODES

Code	Page	Code	Page	Code	Page	Code	Page
XYAA5151	23						
XYAA5190	20						
XYAA5259	23						
XYAA5260	23						
XYAA5322	19						
XYAA5506	21						
XYAA5699	14						
XYAA5795	6						
XYAA5796	6						
XYAA6261	17						
XYAA6262	17						
XYAA6332	7						
XYAA6358	23						
XYAA6388	14						
XYAA6389	14						
XYAA7928	8						
XYAA9394	12						

Printer  
**PR 2**  
SERVICE MANUAL

Code 683310H-00



**olivetti**

**Printer**  
**PR 2**  
**SERVICE MANUAL**

Code 683310H-00

PUBLICATION ISSUED BY:

Olivetti Lexikon, S.p.A.  
Documentazione  
77, Via Jervis - 10015 Ivrea (Italy)

*Copyright © 1997, by Olivetti  
All rights reserved*

*Printed in Italy by:*

## PREFACE

This service manual provides the technical information needed to install, test and service the PR 2 specialized printer.

This manual should be consulted whenever it has not been possible to eliminate a fault through the solutions suggested in the operating manual which is enclosed with the printer.

### SUMMARY

This manual is divided into chapters.

The sequence of the chapters is arranged to aid the technician when searching for information.

The first two chapters deal with the machine and the main commands; chapter three describes the installation and tests; the remaining chapters give further information for efficient field servicing.

Where possible, reference has been made to machines with all the options (maximum configuration).

If models for some of these options are not present, just ignore the parts referring to them.

- **BIBLIOGRAPHY:** PR 2 User manual  
PR 2 Programmer's Manual  
PR 2 Spare parts catalogue
- **SECTOR/RANGE PRODUCT:** Q2 PR 2
- **DISTRIBUTION:** General (G)
- **FIRST EDITION:** March 1997

---

### NOTICE

Olivetti Lexikon, S.p.A. reserves the right to modify the equipment described in this manual at any time and without notice.

---





# TABLE OF CONTENTS

<b>1. OVERVIEW</b> .....	<b>1-1</b>
1.1 INTRODUCTION .....	1-1
1.1.1 PR 2 FACTORY DEFAULT CONFIGURATION .....	1-1
1.2 MACHINE GENERAL CHARACTERISTICS .....	1-2
1.3 PRODUCT VARIABLES .....	1-5
1.4 DOCUMENTS THAT CAN BE PROCESSED BY THE BASIC MACHINE .....	1-6
1.4.1 SINGLE AND MULTICOPY MODULES .....	1-6
1.4.2 BANK BOOKS .....	1-7
1.5 ACCESSORIES .....	1-8
1.6 LOCATION OF MAJOR CONTROLS .....	1-9
1.7 LOCATION OF MAJOR COMPONENTS .....	1-10
1.8 GENERAL BLOCK DIAGRAM .....	1-11
1.9 FIRMWARE AND CHARACTER GENERATORS .....	1-12
1.9.1 MACHINE FIRMWARE .....	1-12
1.9.2 CHARACTER SET .....	1-13
1.9.3 PRINT MODES AND CHARACTER FONTS .....	1-14
<b>2. OPERATING COMMANDS</b> .....	<b>2-1</b>
2.1 POWER SWITCH .....	2-2
2.2 CONSOLE .....	2-2
2.2.1 MEANING OF THE KEYS .....	2-3
2.2.2 MEANING OF THE LEDS .....	2-4
2.2.3 ERROR MESSAGES .....	2-4
2.3 UPPER MECHANICAL ASSEMBLY LIFTING LEVER .....	2-6
<b>3. INSTALLATION</b> .....	<b>3-1</b>
3.1 GENERAL INSTALLATION PRECAUTIONS .....	3-1
3.1.1 ELECTRIC POWER SUPPLY .....	3-1
3.1.2 ENVIRONMENT CONDITIONS .....	3-1
3.1.3 MOVING THE MACHINE .....	3-1
3.2 UNPACKING AND INSTALLATION .....	3-2
3.2.1 UNPACKING.....	3-2
3.2.2 MACHINE INSTALLATION .....	3-4
3.3 OFF-LINE TESTS .....	3-4
3.3.1 STARTING THE PRINT TEST .....	3-4
3.3.2 PRINT TEST CONTENTS .....	3-5
3.3.3 TEST ANALYSIS AND EXITING THE TEST ENVIRONMENT .....	3-6
3.4 CONNECTION TO THE SYSTEM .....	3-6
3.4.1 RS 232C SERIAL INTERFACE .....	3-6
3.4.2 IEEE 1284 PARALLEL INTERFACE .....	3-7
3.5 FINAL TESTING .....	3-8
3.6 INFORMATION FOR THE OPERATOR.....	3-8
3.7 OPERATING PROCEDURES .....	3-9
3.7.1 DOCUMENT INSERTION WITH AUTOMATIC ALIGNMENT .....	3-9
3.7.2 SAVINGS BOOK INSERTION WITH MANUAL ALIGNMENT .....	3-9
3.7.3 EXPULSION OF PROCESSED DOCUMENTS .....	3-10
3.7.4 REPLACING THE RIBBON CARTRIDGE .....	3-11
3.7.5 PAPER JAMS .....	3-15

<b>4. AUTODIAGNOSTICS, SETUP AND SETTINGS .....</b>	<b>4-1</b>
4.1 POWER-ON DIAGNOSTICS .....	4-1
4.2 PRINT TEST .....	4-2
4.3 MACHINE SET-UP .....	4-2
4.3.1 SET-UP ACTIVATION .....	4-2
4.3.2 CONFIGURATION PARAMETERS .....	4-6
4.4 ADJUSTMENTS THE PHOTSENSORS .....	4-18
4.4.1 ADJUSTING BIDIRECTIONAL PRINTING ALIGNMENT .....	4-24
4.4.2 ADJUSTING THE TOF OF FORM (TOF) .....	4-26
4.4.3 ADJUSTING THE LEFT PRINT MARGIN .....	4-28
4.4.4 MEASURING THE LENGTH OF THE DOCUMENT .....	4-30
4.4.5 HORIZONTAL MAGNETIC UNIT OPTION ADJUSTMENT - SKEW AND SIGNAL AMPLITUDE CONTROL .....	4-32
4.4.6 ADJUSTING THE VERTICAL MAGNETIC UNIT OPTION - SKEW AND SIGNAL AMPLITUDE CONTROL .....	4-34
4.4.7 ADJUSTING THE CHECK READER ON THE PR 2 .....	4-36
<b>5. DIAGNOSTICS GUIDE .....</b>	<b>5-1</b>
5.1 SERVICING METHODS .....	5-1
5.1.1 INFORMATION CONCERNING THE FAULT .....	5-1
5.1.2 OPERATING CONDITIONS ANALYSIS .....	5-1
5.1.3 PINPOINTING THE PROBLEM .....	5-2
5.1.4 FINDING THE CAUSE .....	5-2
5.1.5 SOLVING THE PROBLEM .....	5-2
5.1.6 MACHINE TESTING .....	5-2
5.2 CLASSIFYING THE FAULTS .....	5-3
5.3 POWER ON FAULTS .....	5-4
5.4 DOCUMENT WRITE FAULTS .....	5-5
5.5 DOCUMENT HANDLING FAULTS .....	5-6
5.6 MAGNETIC STRIPE READ/WRITE FAILURES .....	5-7
<b>6. ELECTRICAL INTERCONNECTIONS .....</b>	<b>6-1</b>
6.1 GENERAL PRINTER CABLING DIAGRAM .....	6-1
6.2 BAPR2 MAIN BOARD .....	6-2
6.2.1 BOARD VIEW AND LOCATION OF CONNECTORS .....	6-2
6.2.2 BOARD LAYOUT AND LOCATION OF CONNECTORS .....	6-3
6.2.3 CONNECTOR SIGNALS .....	6-5
6.3 ALIPR2 BOARD .....	6-7
6.3.1 BOARD VIEW AND LOCATION OF COMPONENTS .....	6-7
6.3.2 CONNECTOR SIGNALS AND FUSE VALUES .....	6-8
6.4 BOARDS FOR MAGNETIC AND MICR OPTIONS .....	6-9
6.4.1 BOARD VIEW AND LOCATION OF CONNECTORS .....	6-9
6.4.2 PR2MAGN BOARD LAYOUT AND LOCATION OF CONNECTORS .....	6-10
6.4.3 PR2MIMAG BOARD LAYOUT AND LOCATION OF CONNECTORS .....	6-12
6.4.4 PR2VER BOARD LAYOUT AND LOCATION OF CONNECTORS .....	6-14
6.5 CONSOLE .....	6-16

<b>7. PREVENTIVE MAINTENANCE .....</b>	<b>7-1</b>
7.1 CLEANING .....	7-1
7.1.1 CLEANING THE PRINTER CASE .....	7-1
7.1.2 CLEANING THE PAPER PATHS .....	7-1
7.1.3 CLEANING THE READING HEAD FOR HORIZONTAL/VERTICAL/MICR MAGNETIC STRIPS .....	7-1
7.2 LUBRICATION .....	7-3
7.2.1 BASIC MACHINE LUBRICATION POINTS .....	7-3
7.2.2 HORIZONTAL MAGNETIC DEVICE LUBRICATION POINTS .....	7-4
7.2.3 VERTICAL MAGNETIC DEVICE LUBRICATION POINTS .....	7-5
<b>8. MECHANICAL ADJUSTMENTS .....</b>	<b>8-1</b>
8.1 BASIC MACHINE ADJUSTMENTS .....	8-2
8.1.1 ADJUSTING THE DOCUMENT FEED BELT .....	8-2
8.1.2 ADJUSTING THE DISTANCE BETWEEN PLATEN AND NEEDLES .....	8-3
8.1.3 ADJUSTING THE DISTANCE OF THE RIBBON/NEEDLE PROTECTION FIN .....	8-4
8.1.4 ADJUSTING THE PAPER PHOTOSENSOR .....	8-5
8.1.5 ADJUSTING THE PRINT BAR .....	8-6
8.1.6 TAB ADJUSTMENTS .....	8-7
8.1.7 ADJUSTING THE ROLLER GEARS .....	8-8
8.1.8 ADJUSTING THE FRONT PRESSURE ROLLERS .....	8-9
8.1.9 ADJUSTING TAB OPENING .....	8-10
8.1.10 ADJUSTING THE TENSION OF THE CARRIAGE MOVEMENT BELT .....	8-11
8.2 ADJUSTMENTS FOR BASIC MACHINE OPTIONS .....	8-12
8.2.1 HORIZONTAL MAGNETIC DEVICE/MICR OPTION - ADJUSTING THE TENSION OF THE CARRIAGE FEED BELT .....	8-12
8.2.2 HORIZONTAL MAGNETIC DEVICE/MICR OPTION - ADJUSTING THE DOOR .....	8-13
8.2.3 HORIZONTAL MAGNETIC DEVICE/MICR OPTION - PRESS POSITIONING .....	8-14
8.2.4 HORIZONTAL MAGNETIC DEVICE OPTION - POSITIONING THE FRAME ASSEMBLY ..	8-15

9.	DISASSEMBLY/REASSEMBLY .....	9-1
9.1	PRELIMINARY PRECAUTIONS .....	9-2
9.2	BASIC MACHINE DISASSEMBLY/REASSEMBLY PROCEDURES .....	9-3
9.2.1	DISASSEMBLING/REASSEMBLING THE CASE .....	9-3
9.2.2	DISASSEMBLING/REASSEMBLING THE CONSOLE .....	9-4
9.2.3	DISASSEMBLING/REASSEMBLING THE MECHANICAL ASSEMBLY .....	9-5
9.2.4	DISASSEMBLING/REASSEMBLING THE PRINT HEAD FLAT CABLE .....	9-6
9.2.5	DISASSEMBLING/REASSEMBLING THE UPPER MECHANICAL ASSEMBLY .....	9-7
9.2.6	DISASSEMBLING/REASSEMBLING THE PRINT HEAD .....	9-8
9.2.7	DISASSEMBLING/REASSEMBLING THE PAPER FEED MOTOR .....	9-9
9.2.8	DISASSEMBLING/REASSEMBLING THE PRINT HEAD MOVEMENT MOTOR .....	9-10
9.2.9	DISASSEMBLING/REASSEMBLING THE SERVICES MOTOR .....	9-11
9.2.10	DISASSEMBLING/REASSEMBLING THE FEEDER PHOTOSENSORS .....	9-12
9.2.11	DISASSEMBLING/REASSEMBLING THE REAR PHOTOSENSOR .....	9-13
9.2.12	DISASSEMBLING/REASSEMBLING THE MAIN BOARD .....	9-14
9.2.13	DISASSEMBLING/REASSEMBLING THE TRANSFORMER .....	9-15
9.2.14	DISASSEMBLING/REASSEMBLING THE TOROIDAL TRANSFORMER .....	9-16
9.2.15	DISASSEMBLING/REASSEMBLING THE POWER ASSEMBLY .....	9-17
9.2.16	REPLACING THE FUSE .....	9-18
9.3	BASIC MACHINE OPTIONS DISASSEMBLY/REASSEMBLY PROCEDURES .....	9-19
9.3.1	DISASSEMBLING/REASSEMBLING THE HORIZONTAL MAGNETIC DEVICE AND MICR ASSEMBLY .....	9-19
9.3.2	DISASSEMBLING/REASSEMBLING THE VERTICAL MAGNETIC HEAD .....	9-20
9.4	CHECK READER OPTION DISASSEMBLY/REASSEMBLY .....	9-21
9.4.1	DISASSEMBLING/REASSEMBLING THE CHECK MODULE SERVICES MOTOR .....	9-21
9.4.2	DISASSEMBLING/REASSEMBLING THE MICR HEAD ASSEMBLY .....	9-22

# 1. OVERVIEW

## 1.1 INTRODUCTION

The PR 2 is a specialized mid-range printer specifically designed for the banking environment. It can handle documents (single or multicopy) or savings books used during cash deposit or withdraw transactions.

Very versatile, this printer can also be used in the Public Administration front office environments and in Post Offices.

It is equipped with two options, one for automatic form feeding and the other for the reading of code lines on checks.

### 1.1.1 PR2 FACTORY DEFAULT CONFIGURATION

The basic version of the PR2 is configured at the factory in two versions that differ according to the type of main board used:

- PR 2 equipped with a main board with an RS232 C serial interface: **PR 2-S10**
- PR 2 equipped with a main board with a double interface, an IEEE 1284 bidirectional parallel interface and an RS232 C serial interface: **PR 2-D10**. By means of the Setup facility, the autoswitching of the interface can be selected.

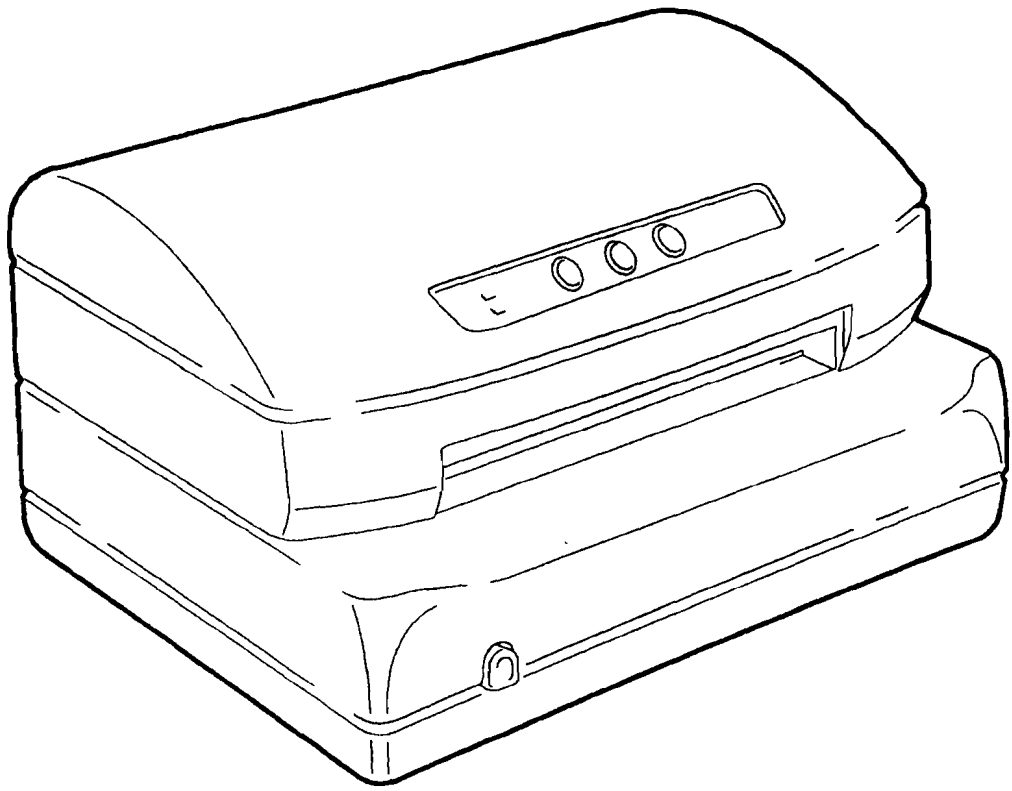
When equipped with a horizontal magnetic band read/write unit, the PR2 printer is named **PR 2-S12** depending on the type of interface it is equipped with. When the printer is equipped with a MICR check reader in addition to the horizontal magnetic band read/write unit, it is named **PR 2-S12MMICR**.

When equipped with a vertical magnetic band read/write unit, the printer is named **PR 2-S13**.

In case the printer comes with the vertical magnetic band option, it will be necessary to specify the savings book alignment to either the left (DOC 007) or right (DOC 009) of the input slot.

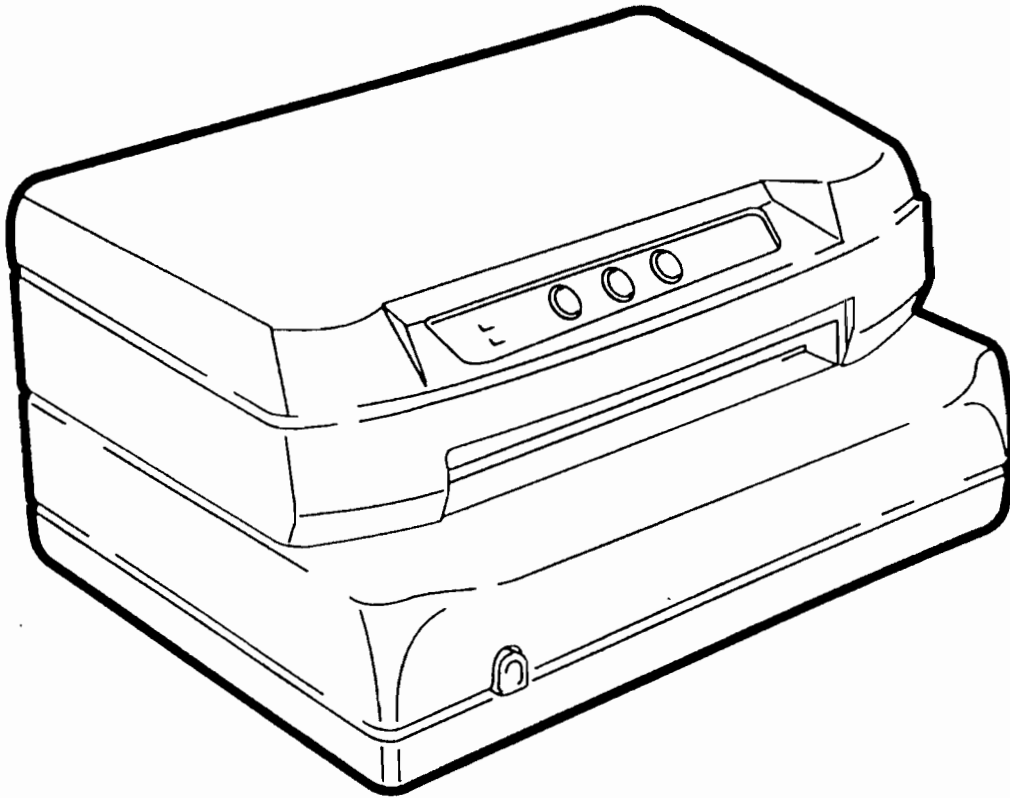
## 1.2 MACHINE OVERALL CHARACTERISTICS

PRINT MODULE	24-needle impact print head Printing capabilities: 1 original + 4 copies Savings book handling capabilities
PRINT SPEED	76 cps @ 1/10" in LQ mode 115 cps @ 1/10" in NLQ mode 230 cps @ 1/10" in DRAFT mode 310 cps @ 1/10" in HSD mode 460 cps @ 1/15" in VHSD mode
PRINT MODE	V.H.S.D., H.S.D., DRAFT, N.L.Q., L.Q.
RIBBON CARTRIDGE	Indelible fabric lasting approximately 2.5 M chars.
PAPER FEED	Front feeder with automatic document alignment facility
DOCUMENT SIZE	245 x 450 mm max. 70 x 70 mm min. See section 1.4 for more details
CONSOLE	Located on the printer case, it has three keys and five LEDs
EMULATIONS	PR 2845, PR 40+, Native PR 2, IBM Proprinter II. The optional IBM 4722/III and SIEMENS NIXDORF ND90 emulations can also be loaded, but are not compatible with the vertical magnetic band unit and with the MICR check reader.
INTERFACE	Serial RS 232C
DIMENSIONS	Width 384 mm; Depth 280 mm; Height 203 mm; Weight 10.5 Kg.
POWER ABSORPTION	Stand-by: $\leq$ 15 W In operation: 170 W max. (worst case)
POWER SUPPLY	115 V ( $\pm$ 10%) 220 to 240 V ( $\pm$ 10%) (depending on the country of destination)



*Fig. 1-1 PR 2 Printer with Rounded Cover*





*Fig. 1-2 PR 2 with Flat Cover*

### 1.3 PRODUCT VARIABLES

VOLTAGE AND FREQUENCY	TEN 023	115V 50/60 Hz
	TEN 204	220/240V 50/60 Hz
POWER CORD	COR 005	Europe
	COR 041	Switzerland
	COR 042	Great Britain
	COR 043	Australia
	COR 050	USA
	COR 080	South Africa
USER'S GUIDE	LIG 001	French
	LIG 002	German
	LIG 003	English
	LIG 005	Spanish
	LIG 006	Italian
	DOCUMENT ALIGNMENT*	DOC 007
DOC 009		Right-hand alignment
COVER	COV 000	
COVER (FLAT)	COV 001	

\* Document alignment must be specified for the PR 2-S13 model.

## 1.4 DOCUMENTS THAT CAN BE PROCESSED BY THE BASIC MACHINE

### 1.4.1 SINGLE AND MULTICOPY MODULES

Maximum width	245 mm
Minimum width	70 mm
Maximum recommended length	297 mm
Maximum accepted length	450 mm
Minimum length	70 mm
Single sheet weight	60 to 160 g/m <sup>2</sup>
Single sheet thickness	0.1 to 0.28 mm
Transparency	Up to 25% and uniform
Multicopy weight (chemical)	40 to 60 g/m <sup>2</sup>
Carbon paper substance	20 to 34 g/m <sup>2</sup>
Maximum printable copies	1+5 with average paper weight and in the LQ print mode 1+3 with average paper weight and in the VHSD print mode
Recommended weight	Original 50 g/m <sup>2</sup> , last copy 60 g/m <sup>2</sup>
Multicopy glueing	At head or on side

## 1.4.2 BANK BOOKS

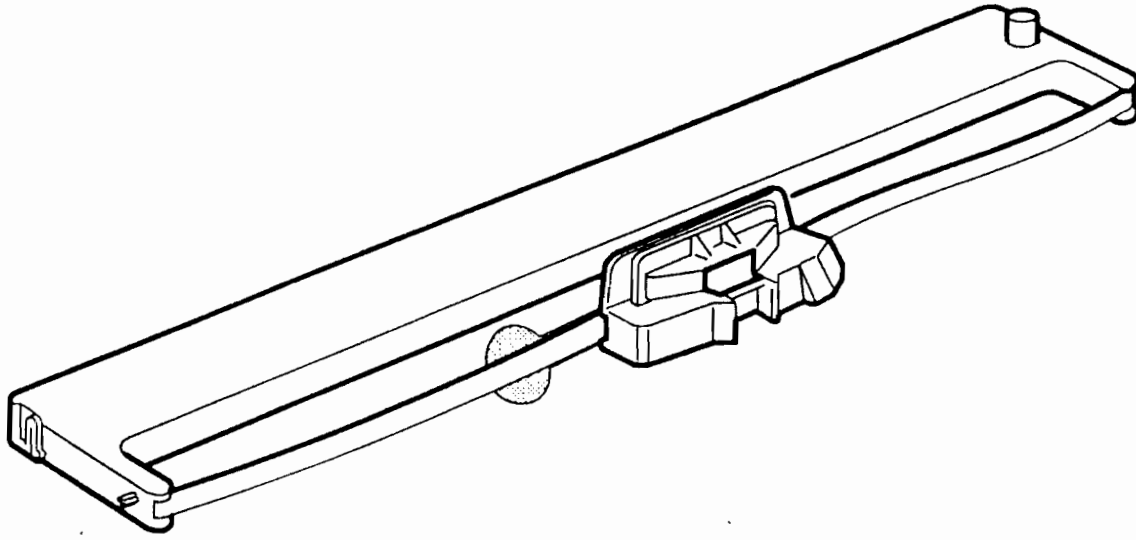
Max. thickness with book open	1.8 mm
Max. difference in levels between pages	1.2 mm
Cover thickness	0.2 to 0.5 mm
Sheets weight	75 to 120 g/m <sup>2</sup>
Type of binding	Sewn with thread, without metal staples or clips
Book preparation	Must be carefully flattened before being inserted into the machine
<i><u>Book with vertical seam</u></i>	
Open book width	241.3 mm/9.5" max.; 110 mm/4.3" min.
Maximum length	220 mm
Minimum length	85 mm
External angles union	3 to 14 mm radius
<i><u>Book with horizontal seam</u></i>	
Open book width	241.3 mm/9.5" max.; 110 mm/4.3" min.
Maximum length	220 mm
Minimum length	165 mm

## 1.5 ACCESSORIES

The machine accessories are:

### ***SNUG CART RIBBON CARTRIDGE***

This ribbon cartridge is specific for needle print heads and lasts more than 2.5 million characters. It can be installed into the printer after removing the front cover.



*Fig. 1-3 SNUG CART Ribbon Cartridge*

## 1.6 LOCATION OF MAJOR CONTROLS

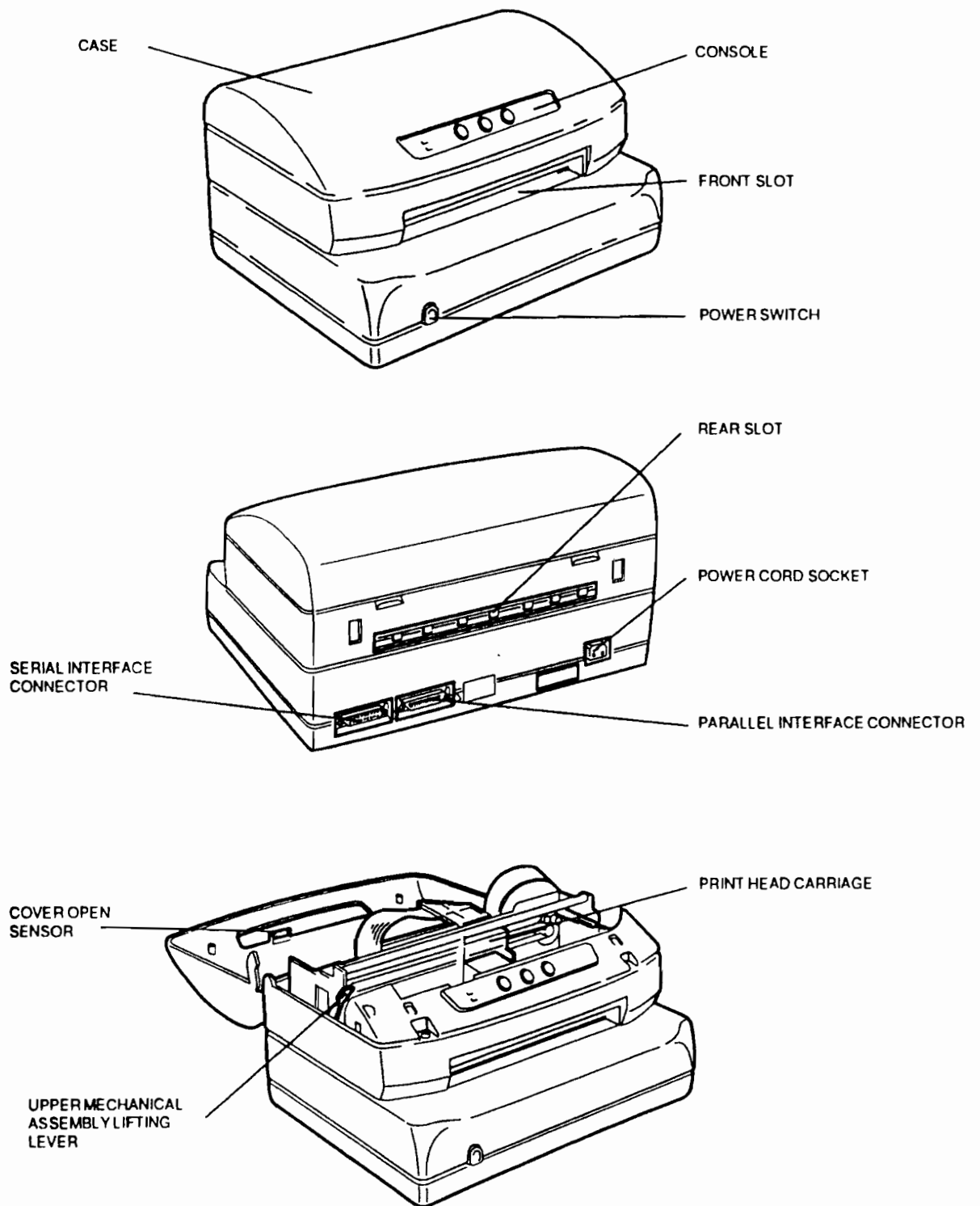


Fig. 1-4 Locating the Major Controls

## 1.7 LOCATION OF MAJOR COMPONENTS

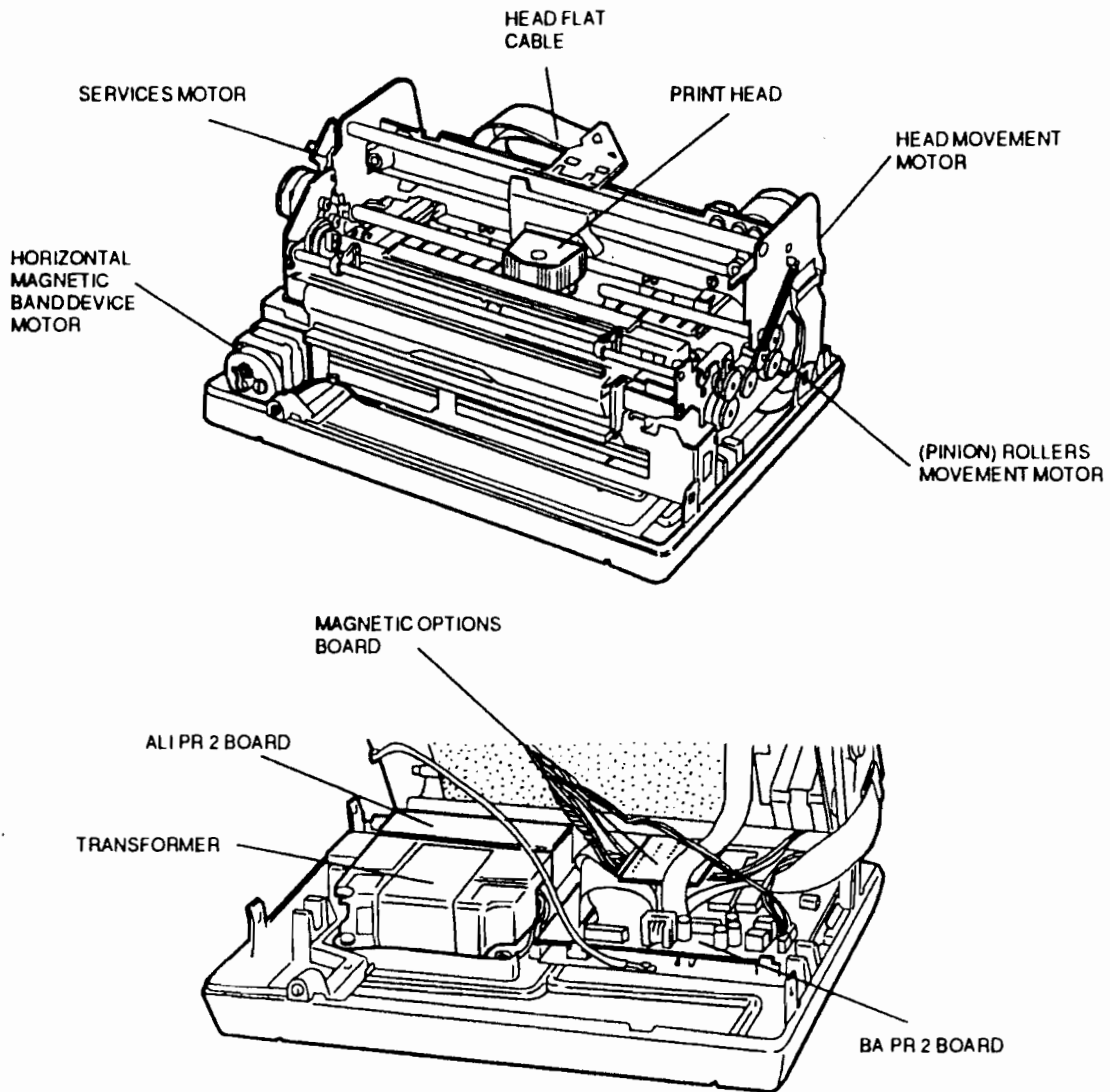
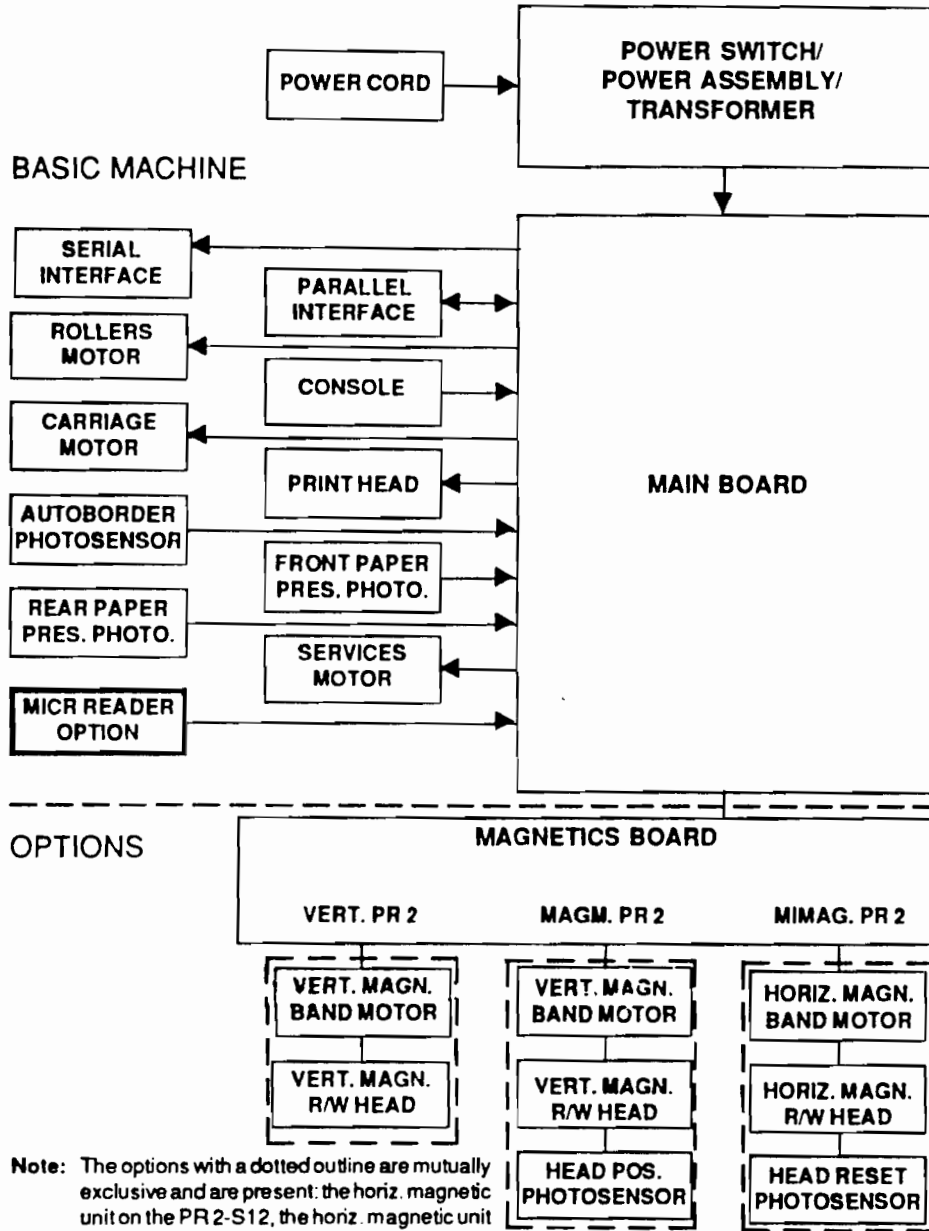


Fig. 1-5 Locating the Major Components

The transformer shown in the figure is installed when no shields are required or in the basic printer version; for noise reduction purposes, a toroidal transformer with appropriate shield is used as indicated in the following table:

	Horiz. Mag. Magn.	Right Vert. Magn.	Left Vert. Magn.	Horiz. Magn. + MICR
No shield	X	X		
Iron shield			X	
Mumetal shield				X

# 1.8 GENERAL BLOCK DIAGRAM



**Note:** The options with a dotted outline are mutually exclusive and are present: the horiz. magnetic unit on the PR 2-S12, the horiz. magnetic unit plus MICR on the PR 2-S12MMICR and the vert. magnetic unit on the PR 2-S13.



## **1.9 FIRMWARE AND CHARACTER GENERATORS**

### **1.9.1 MACHINE FIRMWARE**

The machine firmware includes the following emulations:

- Olivetti PR 40+, PR 2845, NATIVE PR 2 and IBM PPII (4021/2)
- IBM 4722
- SNI 4904 (ND90 - Siemens Nixdorf environment)

The layout of the documents processed by the emulated machines and options is respected without limitations.

The emulations and character generators are contained in EPROM memories or, optionally, in Flash EPROM.

On machines equipped with a Flash EPROM, the basic FW can be upgraded or customized (such as for non-standard products) by means of the DLL procedure. For this purpose the field engineer will be provided with a diskette containing the needed instructions.

### 1.9.2 CHARACTER SET

The system compatibility for each character set covers the environments listed below:

ENVIRONMENT	CHARACTER SET
PC/DOS	CP SET, CODE PAGE
WIDOWS 2.X, 3.0; OS/2; UNIX	ISO 8859/X
WINDOWS 3.1	CP SET
OLIVETTI	STD 15

Each emulation in the machine has one or more associated character sets. The character sets that are available with each emulation are listed in the following table:

EMULATION	CHARACTER SETS
OLIVETTI	CP SET, STD 15 Olivetti
IBM	CP SET, ISO
SNI	CP SET

### 1.9.3 PRINT MODES AND CHARACTER FONTS

The following table lists the characteristics of the different print modes:

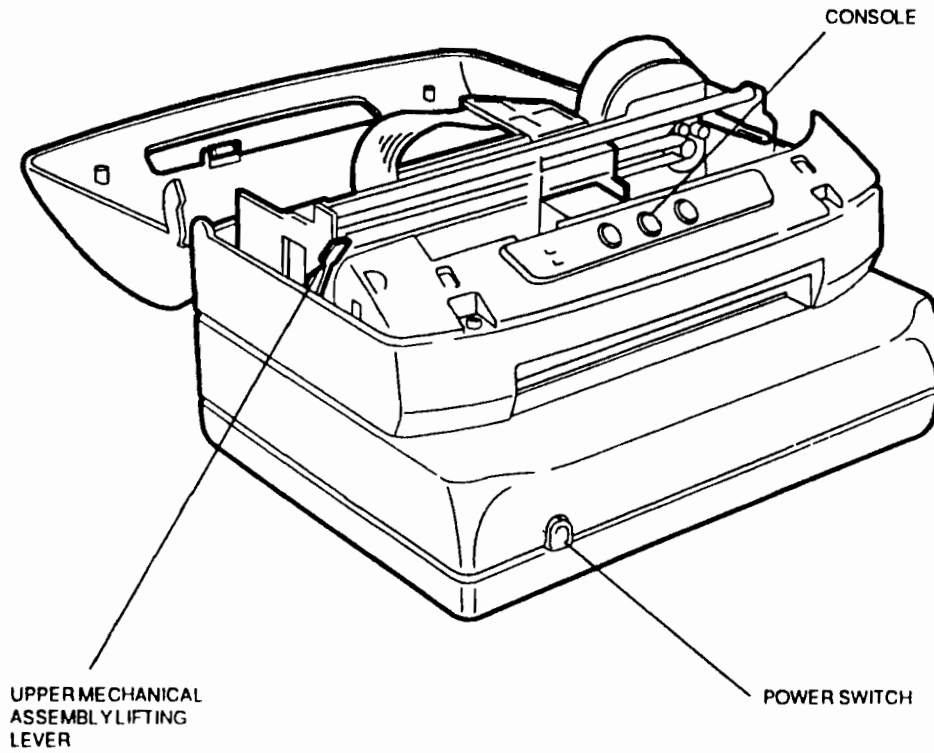
	10 cpi	12 cpi	15 cpi
- V.H.S.D. (Very High Speed Draft)	330 cps	400 cps	460 cps
- H.S.D. (High Speed Draft)	310 cps	277 cps	290 cps
- DRAFT	230 cps	230 cps	230 cps
- N.L.Q. (Near Letter Quality)	115 cps	115 cps	115 cps
- L.Q. (Letter Quality)	76 cps	92 cps	115 cps

The reference standard for optical characters are:

Font	Code standard	Std dimensions/shape	Print specifications
OCR A	EUROBANKING	ISO 1073/1	ISO 1831
OCR B	EUROBANKING	ISO 1073/2	ISO 1831

## 2. OPERATING COMMANDS

Following are the printer's operating commands: power switch, console and upper mechanical assembly lifting lever.



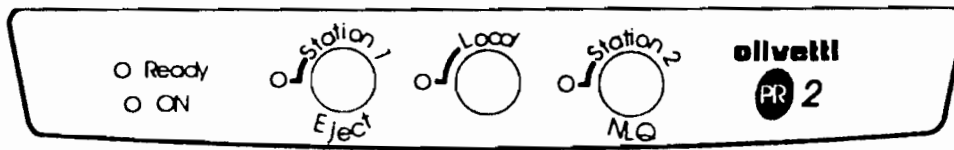
*Fig. 2-1 Operating Commands*

## 2.1 POWER SWITCH

The printer has a bipolar power switch located on the power supply board immediately below the power socket. The switch on/off command is sent through a rod that crosses the printer longitudinally.

## 2.2 CONSOLE

The machine console has five LEDs and three keys.



*Fig. 2-2 Console*

The console also includes a circuit breaker (Dry-reed) that informs the board logics when the machine's top cover is opened.

During the machine set-up (section 4.3) or other set-up (section 4.4), the keys are assigned different meanings for the various procedures.

## 2.2.1 MEANING OF THE KEYS

The keys have the following functions:

- LOCAL** Switches the machine status from Local (off-line) to Ready (on-line) and vice-versa.
- STATION 1/  
EJECT** With Olivetti interpreter, it assigns the machine to operator 1.  
With the IBM PP III emulation resident, it ejects any document that is in the machine.
- STATION 2/  
NLO** With Olivetti interpreter, it assigns the machine to operator 2.  
With the IBM PP III emulation resident, it switches the print mode from Draft to NLO or vice-versa.

If one or more keys are kept pressed down during the machine power-on and reset, other machine states can be accessed. If the top cover is removed and the console is controlled directly during the machine power-on and reset, the meaning of the keys varies.

The following table provides the meaning of the keys in both situations.

Local	ST. 1	ST. 2	Cover open	MACHINE STATUS
		X		Print test
	X	X		Set-up
	X		X	Paper removal procedure
X	X		X	Printer set for the updating of the firmware from the line (on Flash EPROM)
X	X	X	X	Access to the following procedures: a) Photosensor adjustment b) User TOF setting c) Left-hand margin setting d) Document or book length measurement e) Print alignment adjustment

### 2.2.2 MEANING OF THE LEDS

The LEDs indicate the following machine states when they light up:

ON	Machine is powered
READY	The printer is ready to receive data from the line. This LED will also flash during the data reception phase
LOCAL	Machine in Local mode (off-line)
STATION 1	In the Olivetti emulation, it indicates that the printer has been assigned to Operator 1
STATION 2	In the Olivetti emulation, it indicates that the printer has been assigned to Operator 2. In the IBM PP II emulation, it prints with NLQ selected. In the IBM emulation and in an out of paper condition, this LED will flash to indicate that there are other data to be printed.

### 2.2.3 ERROR MESSAGES

The table on the next page shows the various configurations of the LEDs (except for the ON LED which is always alight) and the meanings.

The faults are classified as follows:

- (1) Fatal error. This generates a machine lock and can only be solved by shutting down the printer and making the necessary repairs.
- (2) Error that can be recovered by the operator removing the cause (paper jam) and then pressing the ST1 key with the cover open.

**2.2.3.1 LED LIGHTING UP CHART, ACCORDING TO FAULT FOUND**

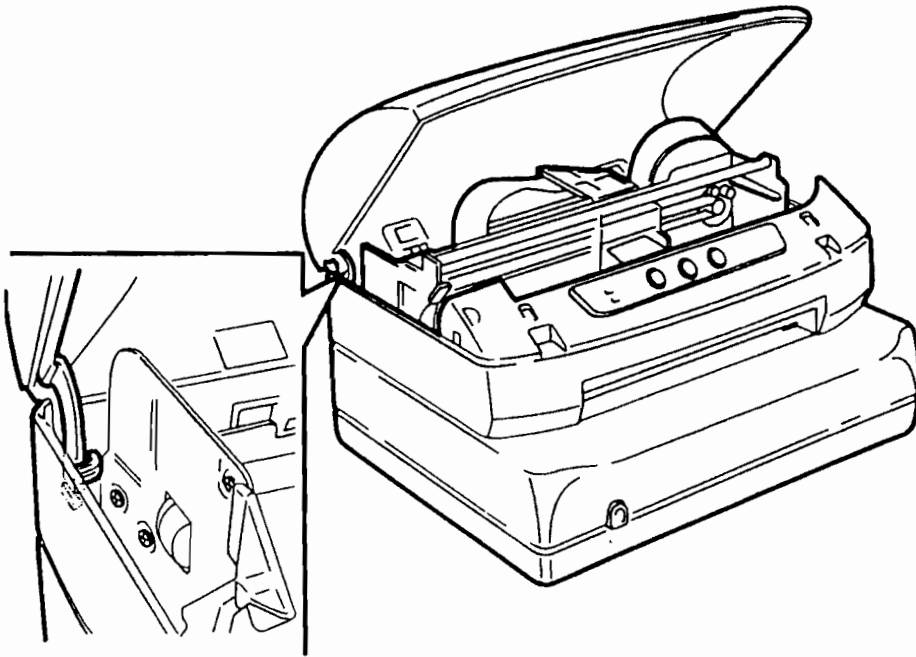
LED	ON	Others
Power supply assy fallure	OFF	OFF
Board failure: - Eprom - ROM - Microprocessor	ON	OFF
Failure on: - Fuses - Drivers - Motors	ON	ON
Activation board failure	The motors do not control any movement	



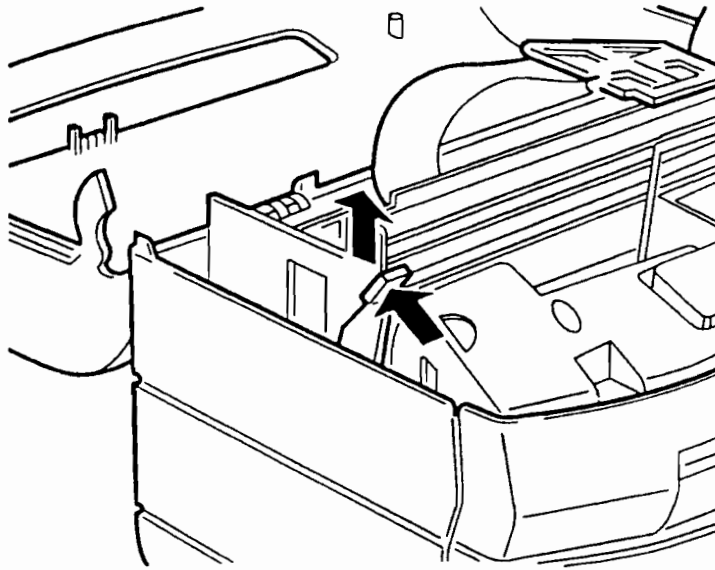
## 2.3 UPPER MECHANICAL ASSEMBLY LIFTING LEVER

This lever is located on the left-hand side of the machine and is used to lift the upper part of the printer assembly to grant access to the internal paper path so that paper jams can be cleared without needing to power off the printer.

To access this lever, lift the printer cover by turning it approximately 45 degrees upwards as far as it goes.

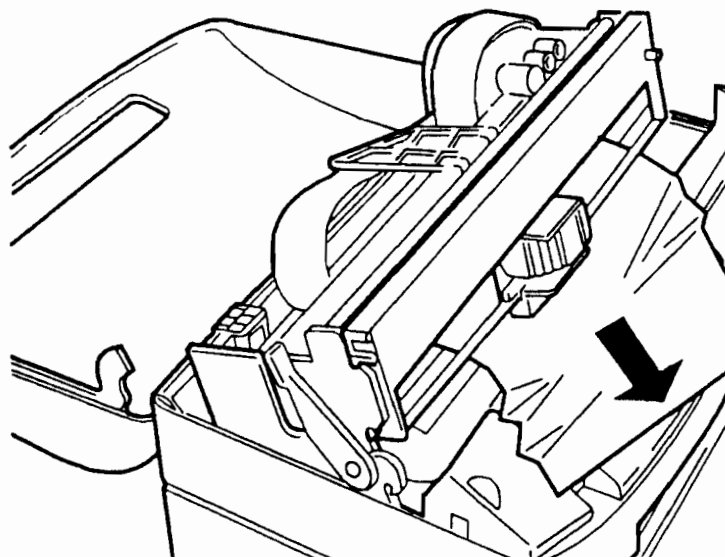


*Fig. 2-3 Opening the Cover*



*Fig. 2-4 Upper Mechanical Assembly Lifting Lever*

Lifting this lever all the way rises the top part of the printer assembly thus granting access to the paper path way.



*Fig. 2-5 Removing Jammed Paper*



## 3. INSTALLATION

### 3.1 GENERAL INSTALLATION PRECAUTIONS

To ensure that the printer operates at its best and to avoid servicing that does not arise from the product, the specifications indicated in the following sections must be observed.

#### 3.1.1 ELECTRIC POWER SUPPLY

Check the socket the printer is connected to ground and is able to supply the power required by the machine. A socket without ground connection could cause operating faults and create safety hazards.

Do not connect the printer to lines in common with equipment that could cause electrical disturbances and excessive voltage fluctuation (fans, air conditioners, powerful photocopying machines, motors for lifts, TV radio transmitters, signal generators, high frequency safety devices and so forth).

Usual office equipment (calculators, typewriters, small photocopying machines, terminals and PC) can be connected on the same line as long as they do not cause high electrical disturbance.

#### 3.1.2 ENVIRONMENT CONDITIONS

The environment conditions in which the product can remain indefinitely are those indicated by the AB quality targets (normal office temperature conditions 15/35 °C, 15/85% RH).

Avoid, both when stored and when operating, that the environment conditions undergo changes that cause condensation.

Dust, dirt and smoke can cause the parts in motion to wear excessively, short circuits (with a high degree of humidity) and read/write errors during the different operations.

High temperatures and low humidity can cause problems due to static electricity.

#### 3.1.3 MOVING THE MACHINE

The printer must be installed on a flat surface, without vibrations. Do not place the printer near to air vents, heat sources or in direct sunlight.

Do not obstruct the printer ventilation slots.

If the machine is inserted into a fitting, make sure that it has good ventilation to prevent overheating that would damage the printer.

Install the machine so that any papers jammed along the document path can be removed.

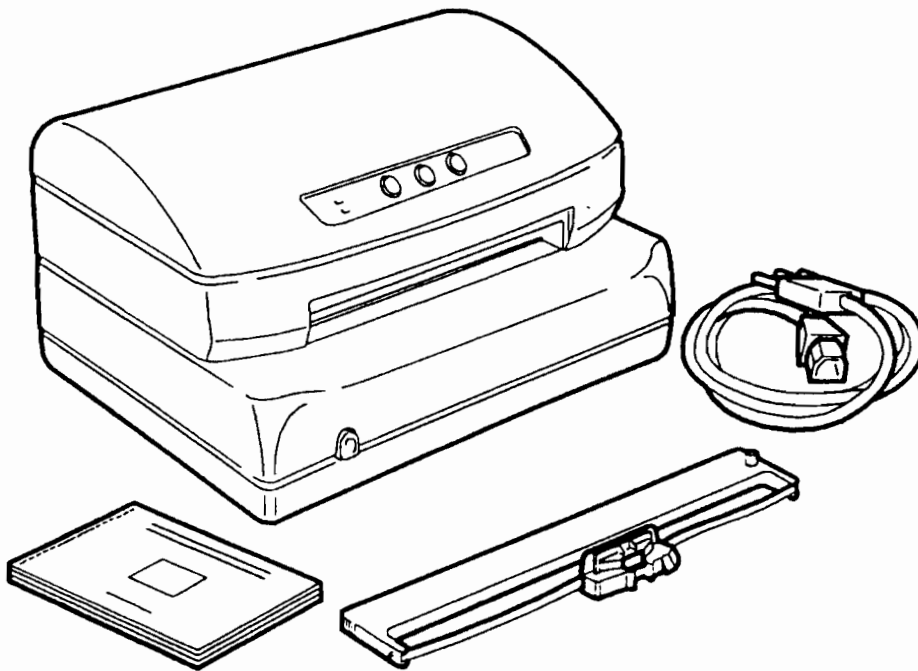
## 3.2 UNPACKING AND INSTALLATION

### 3.2.1 UNPACKING

#### *Checking the contents*

The following items should be contained in the packing:

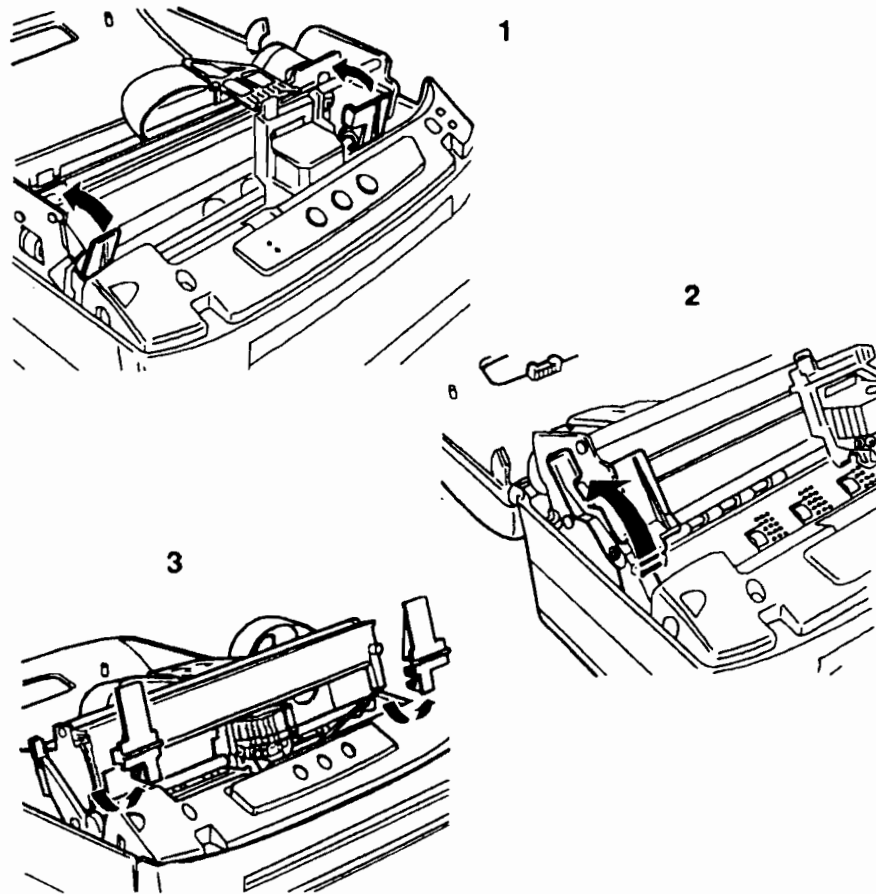
- PR 2 in the requested configuration
- Main cable
- User's manual
- Ribbon cartridge for the needles head
- Cleaning card for models with the horizontal/vertical /MICR magnetic option (not shown in the figure below).



*Fig. 3-1 Package Contents*

### **Printer start UP**

- Remove the machine from the protective bag
- Completely open the printer's top cover
- Remove the two plastic brackets that block the print carriage and the top part of the printer in place during transportation



*Fig- 3-2 Removing the Securing Devices*

- Make a quick check that the printer has not been damaged in transport
- Install the ribbon cartridge (sect. 3.7.4)
- Fit the cover back into place.

### **3.2.2 MACHINE INSTALLATION**

Position the machine where it will be operating, checking that the conditions set out in section 3.1 are respected.

Make sure that the voltage indicated on the network plate is the same as the local power supply. Connect the main cable and power on the printer.

Verify that it is powered by checking the mechanical reset and lighting up of the ON LED on the console.

If other LEDs remain lit other than the ON LED, consult section 2.2.3 "Error Messages".

### **3.3 OFF-LINE TESTS**

To check the printer functionality before connecting it to the system, a print test can be made.

#### **3.3.1 STARTING THE PRINT TEST**

- To start the test, proceed as follows:
- Power off the printer
- Power up the machine keeping the ST2 key on the console pressed down
- After the reset, insert an A4 sheet into the infeed device so as to activate the paper alignment photosensor
- The machine will automatically feed in the sheet and after printing will expel it
- To repeat the print-out insert a new sheet into the machine.

### 3.3.2 PRINT TEST CONTENTS

The test gives the following Information:

- The firmware release installed on the boards in the machine.
- A visual verification of the functions of the print head's 24 needles
- The emulation currently used
- The current printer parameters and options, when installed.

On this page (Fig. 3-3) an example is given of the information supplied by the test. The contents of the print test depend on the FW release Installed on the PR 2.

```

FW REL. 3.22E VER. 233  CG VER. 116

Needles test:
1 1 1 1 1 1 1 1 1 1 1 1 2 2 2 2 2 2 1 1
1 2 3 4 5 6 7 8 9 0 1 2 3 4 5 6 7 8 9 0 1 2 3 4 D E
CONFIGURATION MODE
EMULATION: OLIVETTI
WAIT TIME: 0.6
EMULATION SELECTION: TEMPORARY
DRAFT SPEED: NORMAL
LQ TYPE: MLQ1
BUZZER: Y
INTERFACE: BS232
BAUD RATE: 9600
BIT/CHAR: 8
PARITY: NONE
STOP BIT: 1
DSR: Y
DCD: Y
PAPER EDGE DETECTION: N
SPECIAL FORMS: N

IBM MENU
PASSBOOK: Y
BINDING: VERTICAL
CHAR SET: PC
PC CHAR SET: 437 (INT)
PC TABLE: TABLE 2
CHAR DEFINITION: DRAFT
CPI: 10
LP+CR: N
CR+LF: N
ZERO SLASH: N
LINE LENGTH: 80
FORM LENGTH: 12
BOTTOM MARGIN IBM-PP LIKE: Y
TOP MARGIN IBM-PP LIKE: Y
PMS SELECTION: N

OLIVETTI MENU
EMULATION: PB40-
PASSBOOK: Y
BINDING: VERTICAL
SIDE: L
LINE BUFFER PB40 LIKE: N
CHAR GENERATOR: OLIVETTI
OLIVETTI CHAR SET: INT
CHAR DEFINITION: DRAFT
CPI: 10
VERTICAL RESOLUTION: 1/240
LP+CR: N
RESET WITH EJECT: Y
TOP MARGIN PB40 LIKE: Y

OPTION HORIZONTAL MSHV
STANDARD: IBM 3604
END-SENTINEL: C
DISPLACEMENT: STANDARD
DUPLICATE: N
RETRY: 3
STRIPS HANDLING: NORMAL
PMS SELECTION: N

```

Fig. 3-3 Example of Print Test



### 3.3.3 TEST ANALYSIS AND EXITING THE TEST ENVIRONMENT

The test gives information concerning the functionalities of the options installed in the machine and on the machine set-up.

A visual analysis of the print also permits an assessment of the printing quality. To exit from this environment, power off the machine.

### 3.4 CONNECTION TO THE SYSTEM

#### 3.4.1 RS 232C SERIAL INTERFACE

Connect the serial cable to the 25-pin CANNON connector on the rear of the machine.

Using the Set-up (Section. 4.3.2) program these interface parameters:  
BAUD RATE: BIT/CHAR; PARITY; STOP BIT; DSR and DCD.

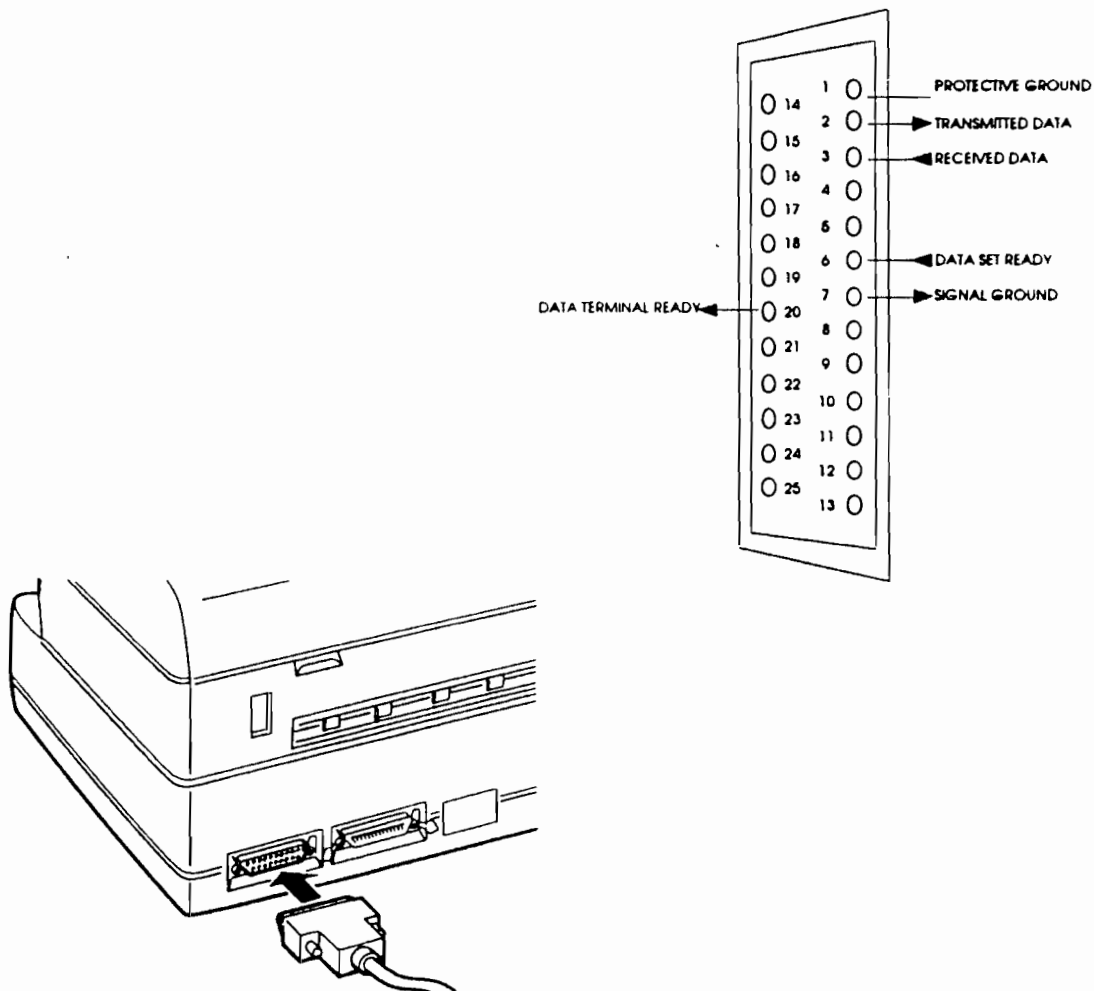


Fig. 3-4 Serial Interface Connector

### 3.4.2 IEEE 1284 PARALLEL INTERFACE

The optional parallel Interface consists of a 36-pin Centronics connector.

The use of an interface cable of up to 1.5 meters long is suggested.

If the printer is equipped with both interfaces, the autoswitching feature can be enabled via Setup. This feature allows the automatic recognition and connection of the printer with the port which is activated first.

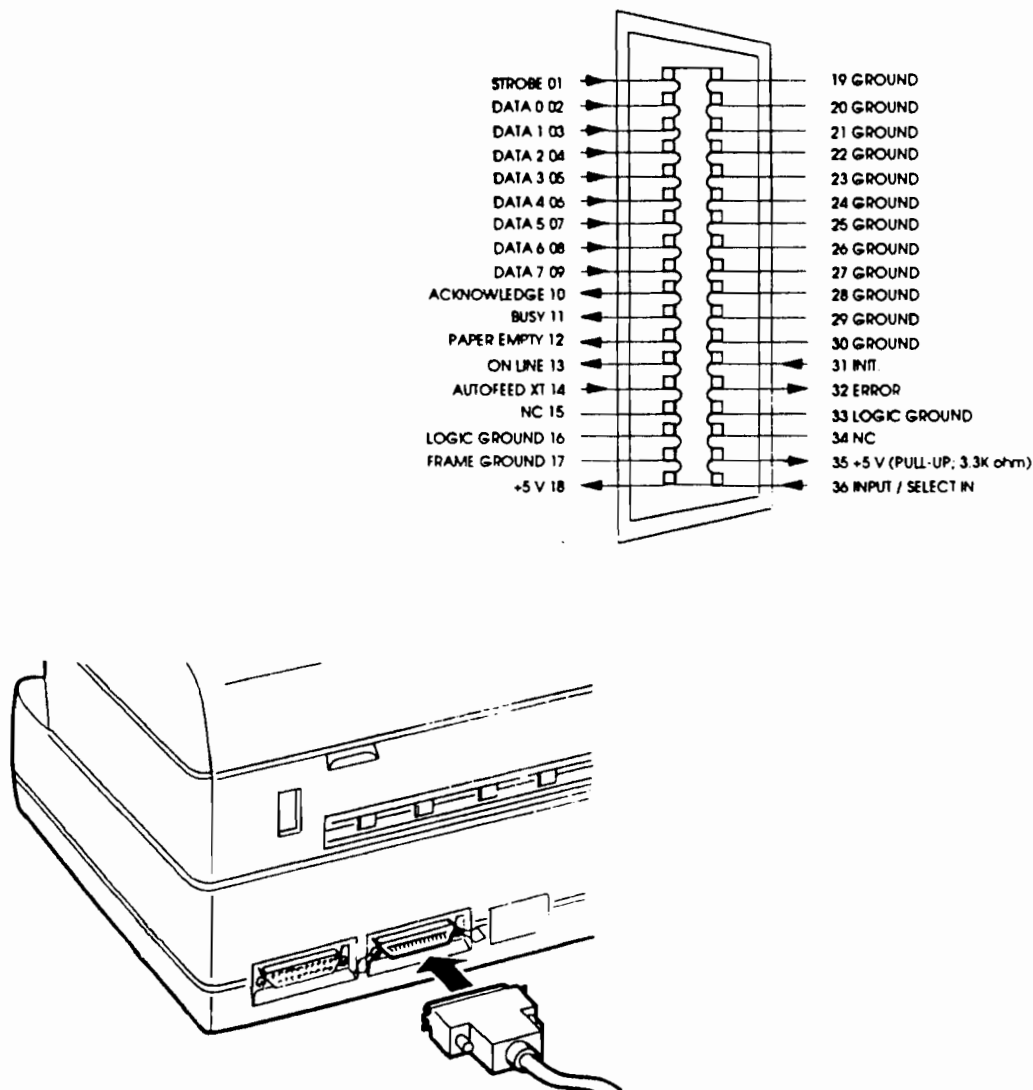


Fig. 3-5 Parallel Interface Connector

### 3.5 FINAL TESTING

After having connected the printer to the system and checked the interface parameters, insert the machine test diskette into the system and activate the test for all machine configuration functions, options included.

### 3.6 INFORMATION FOR THE OPERATOR

After installation the Technician will give the Operator some information on how to operate the machine, replace cartridges and remove jammed paper without problems. It is recommended that a practical demonstration is given for the following operations:

- How to use the console. Interpretation of error messages and, where it is possible, how to release the machine (2.2).
- Inserting passbooks and documents into the feeder, underlining the importance of avoiding the use of crumpled or torn documents, or with jutting spines. Show how to insert the paper (automatic alignment) and of the passbook (manual alignment).
- Replacing the ribbon cartridge.
- Removing a jammed document from the machine using the mechanical lifting levers.
- Inserting a check or tab in the check reader making sure to avoid using documents that are not torn, wrinkled, folded, stapled or with paper clips.

Underline the importance of a good internal ventilation and therefore the need to keep the printer vents free from papers and documents.

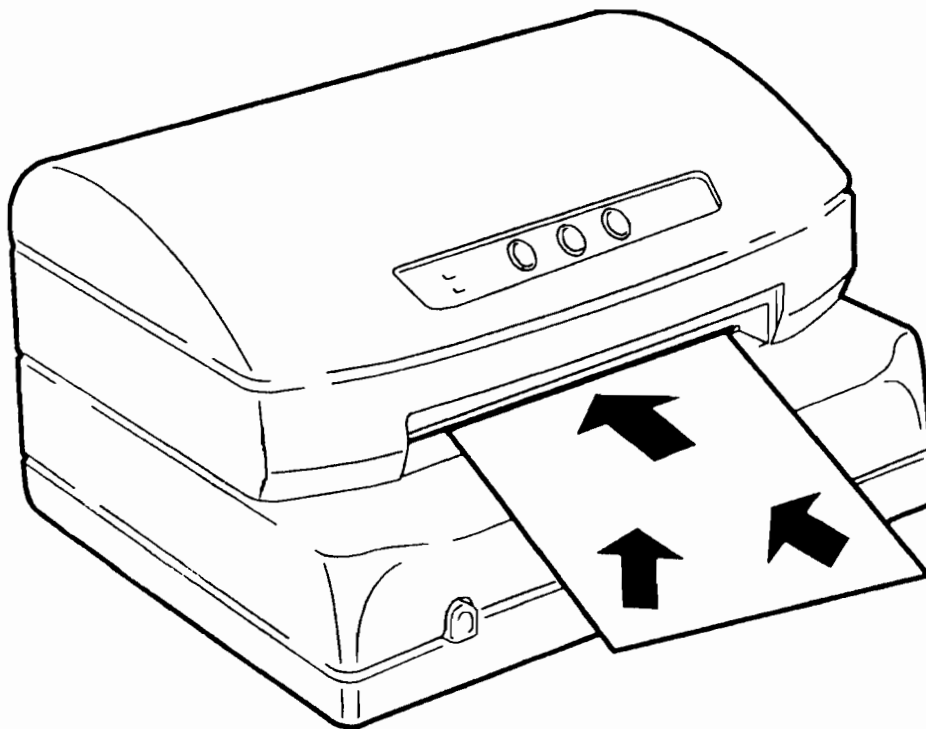
Remember that observing these simple precautions ensures good printer functioning. However, should faults occur, call the servicing engineer without wasting time.

## 3.7 OPERATING PROCEDURES

### 3.7.1 DOCUMENT INSERTION WITH AUTOMATIC ALIGNMENT

The front shelf on the case helps the inspection of the document into the machine.

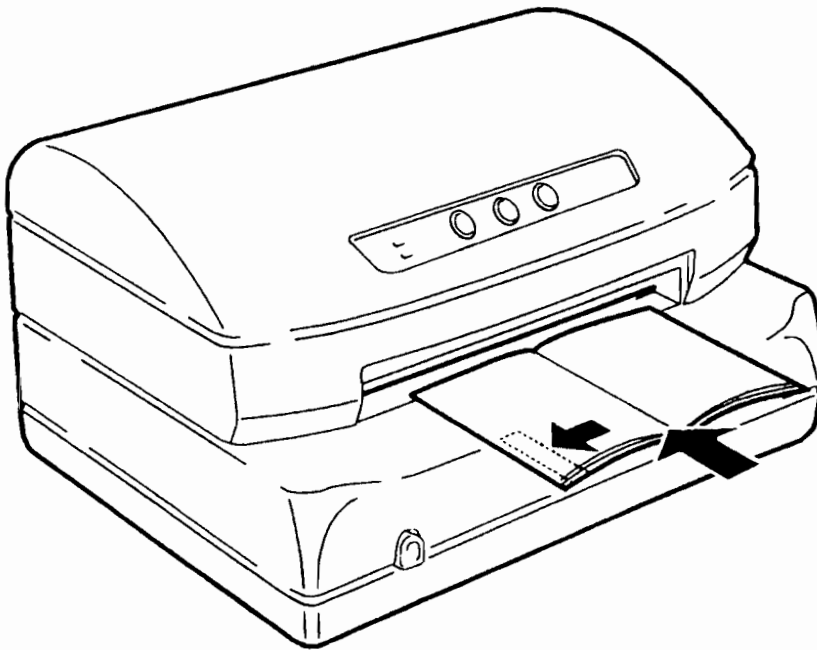
- With the printer powered, place the document at the center of the front slot and insert it into the feed slot.
- Let the document go as soon as the automatic alignment system starts operating.
- Before inserting a passbook, fold it along its spine so that it remains fully open in a horizontal position and check that the pages are not folded or torn to avoid a bad quality print and creasing of the page when inserting.



*Fig. 3-6 Automatic Document Insertion*

### 3.7.2 SAVINGS BOOK INSERTION WITH MANUAL ALIGNMENT

- The savings book must be aligned manually if the printer is equipped with the vertical magnetic band device option and if the book has a magnetic strip on its cover.
- During insertion, the savings book with magnetic strip must be placed against the side of the insertion slot (right or left depending on the magnetic installed in the printer).
- Place the savings book on the open front shelf with its magnetic strip facing downwards. Then, move against one of the sides of the insertion slot and the printer will automatically capture it.



*Fig. 3-7 Savings Book Manual Insertion*

- The savings book will have to be positioned within 3 mm from the right or left sides of the insertion slot; if it is not, upon reception of the magnetic stripe read/write command the printer will inform the PC of a bourrage condition.

### **3.7.3 EXPULSION OF PROCESSED DOCUMENTS**

The processed documents can be ejected from the machine, according to the user program, in the following way:

- Returning back to where they were manually introduced (line feed device).
- From the machine rear slot, starting from the front feeder.

The documents are expelled from the front feed slot as follows:

- When shorter than 100 mm, they will be released by the feed rollers
- When 100 mm or longer, they will remain gripped by the last set of rollers to avoid that the document tails off the front shelf.

If the processed document does not come out of the machine, consult section 3.7.5.

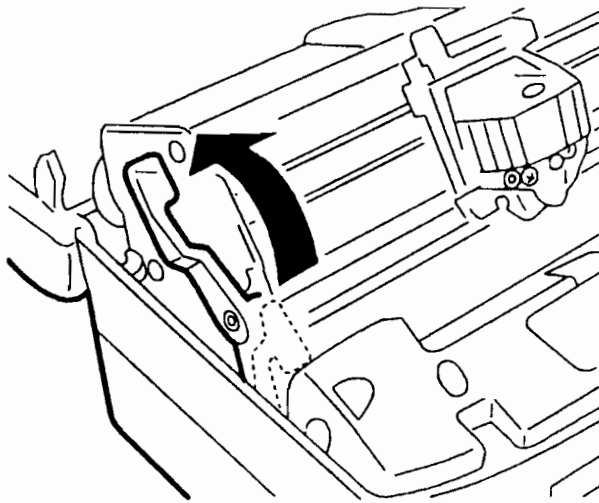
### **3.7.4 REPLACING THE RIBBON CARTRIDGE**

The ribbon cartridge must be changed when the printing becomes incomplete or faded, or when there are frequent optical reading errors on the printed documents.

To change the cartridge, follow the procedure below without powering off the machine:

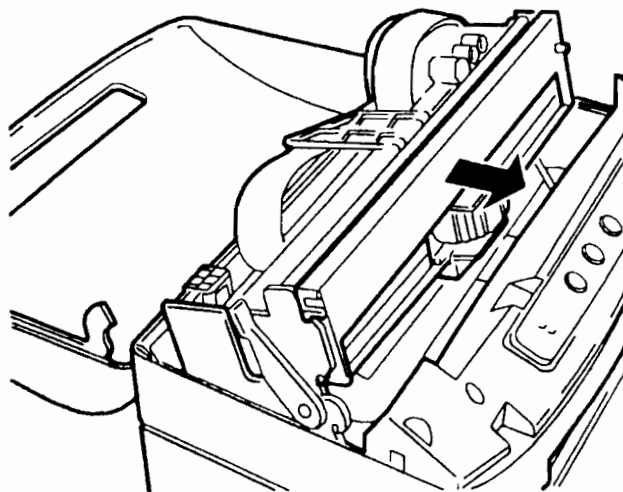
- Open the printer top cover by turning it upwards. Printing stops automatically.

- Using the appropriate lever, lift the upper assembly.



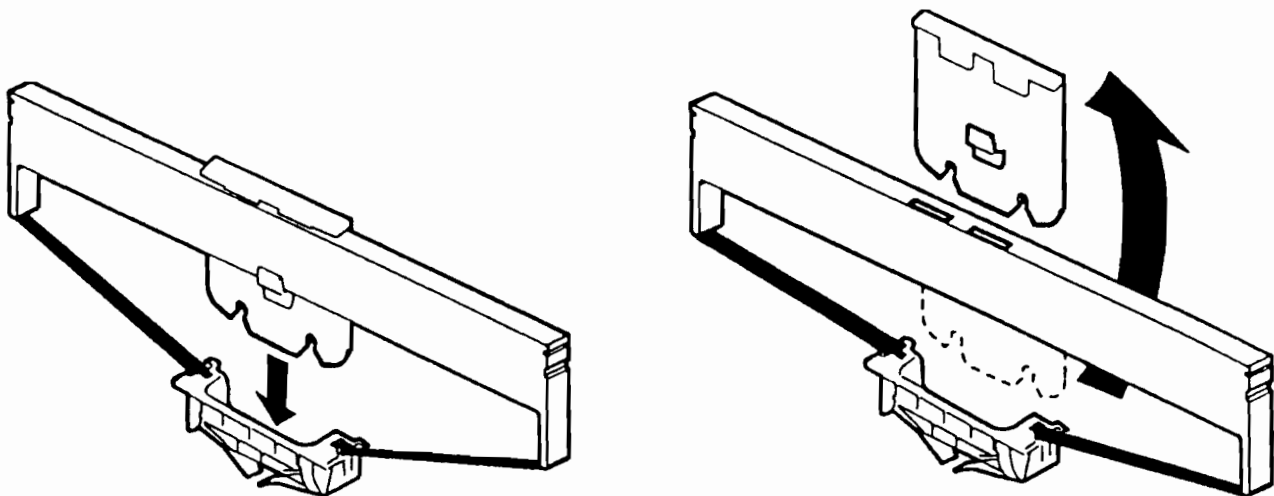
*Fig. 3-8 Releasing the Ribbon Guide*

- Push the ribbon guide downwards until it releases from the print carriage.
- Remove the old cartridge by pulling it outwards.



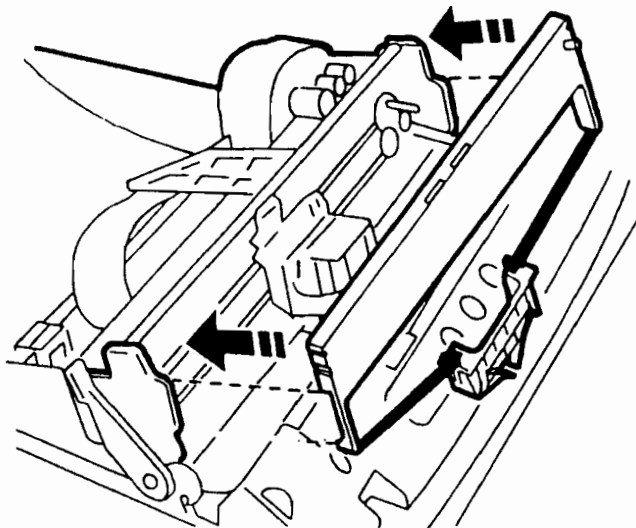
*Fig 3-9 Removing the Ribbon Cartridge*

- Unpack the new cartridge, remove the device that secures the ribbon guide to the body of the cartridge.



*Fig. 3- 10 Unpacking the New Cartridge*

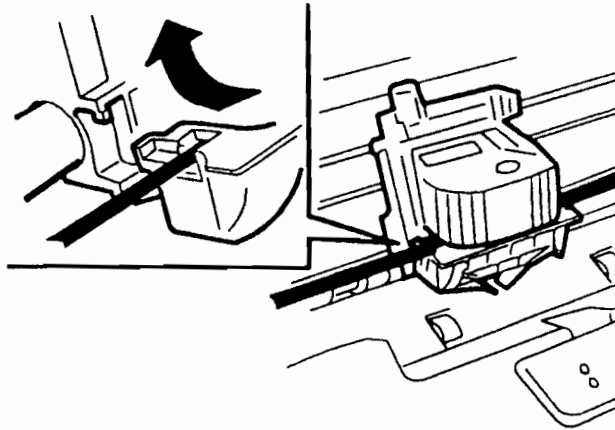
- Manually move the print head towards the center of the machine. Insert the cartridge into the feed gear by hooking it on the two sides.



*Fig. 3-11 Hooking the Cartridge to the Structure*

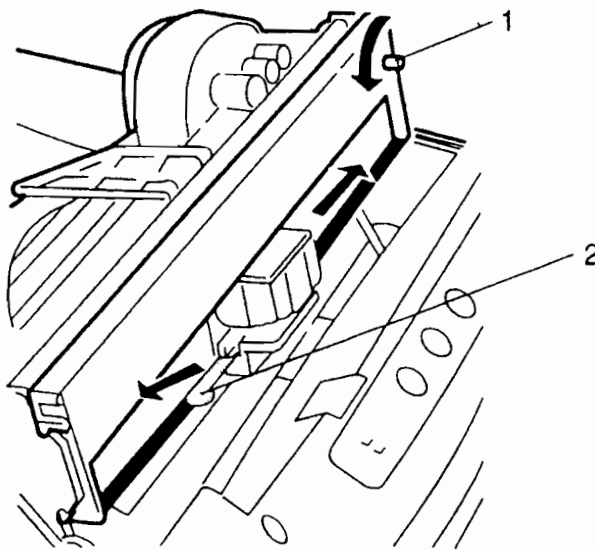


- Insert the ribbon guide frontwards and then move it upwards until it hooks on to the two elastic pins to the carriage's open slots behind the print head platen (a "clack" is heard).



*Fig. 3-12 Hooking the Ribbon Guide*

- Turn the cartridge knob counter clockwise (1) until the ribbon is tight and then remove the tab (2).



*Fig. 3-13 Removing the Tab*

- With the specific lever, completely lower the upper part of the machine containing the print head and ribbon cartridge.
- Close the printer cover.

### 3.7.5 PAPER JAMS

Paper could become jammed along the internal path of the machine.

The jamming could be caused by one of the following:

- Paper path obstructed (residual paper for instance)
- Paper incorrectly fed
- Paper weight or size over the permitted limits
- Paper in bad condition: crumpled, deformed or in a bad state of preservation
- Paper with metal staples or paper clips (this can seriously damage the machine)
- Multicopy forms with badly glued sheets.

The areas where jamming is most likely to occur are:

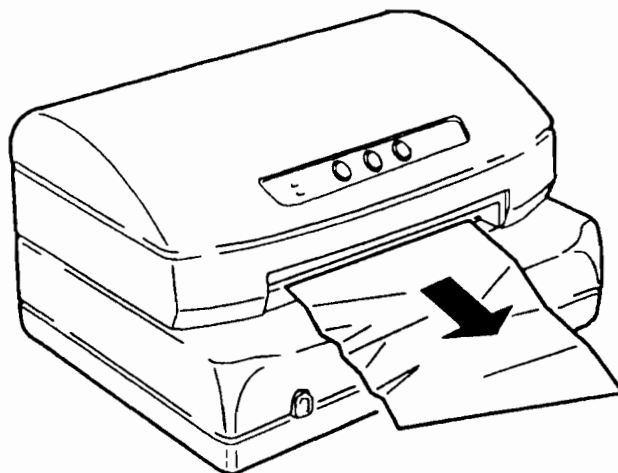
**A** front document insertion slot

**B** inside the printer

**C** rear document output slot

#### 3.7.5.1 PAPER JAMS AT THE FRONT DOCUMENT INSERTION SLOT

To remove a jammed document from area A (front feeder), carefully pull the document from the printer to avoid ripping it.

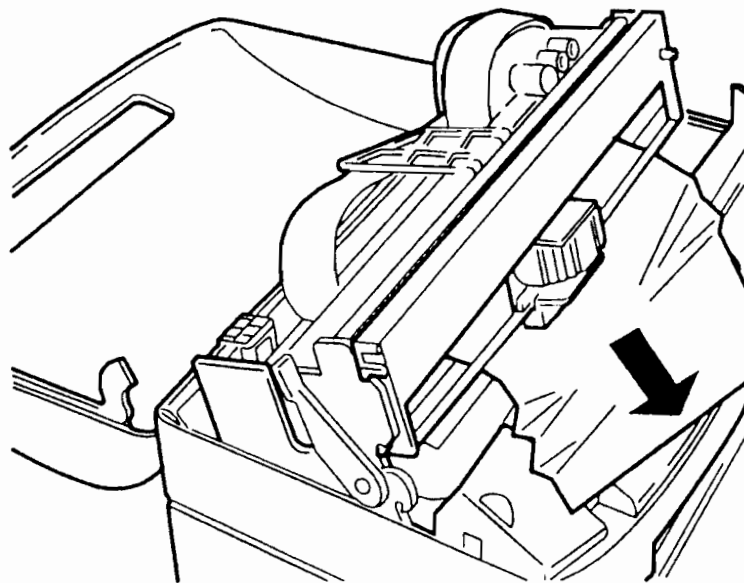


*Fig 3-14 Removing the Document from the Front Insertion Slot*

### 3.7.5.2 PAPER JAMS INSIDE THE PRINTER

Proceed as follows to remove a document from area B (inside the printer):

- Open the cover without powering off the printer
- Lift the upper assembly by using the appropriate lever
- Remove the jammed document by pulling it carefully



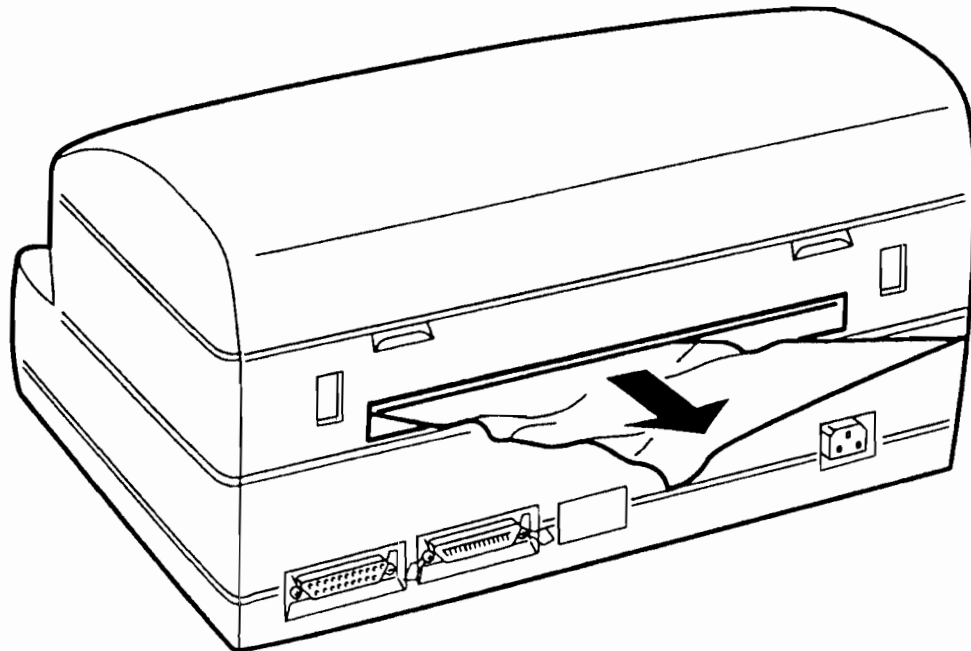
*Fig 3-15 Removing a Document from Inside the Printer*

If some pieces of paper remain jammed in inaccessible areas inside the printer, proceed as follows to remove them:

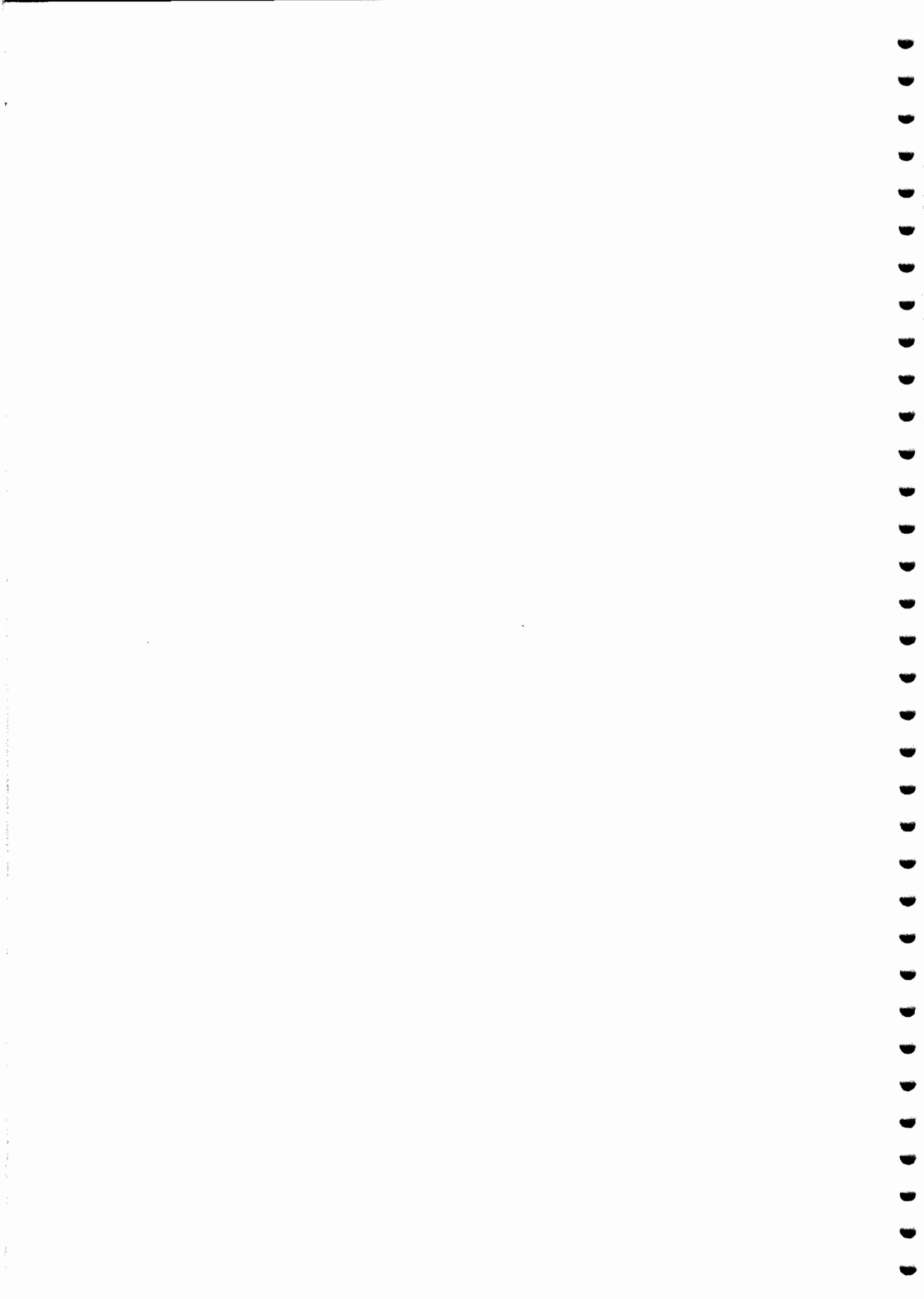
- 1) Open the cover and power on the printer with the ST1 key pressed,
- 2) Wait for the audible signal to sound.
- 3) By pressing ST1 and/or ST2 (key 3, without any indication, for machines running the SNI ND 90 emulation) the paper will be moved forward/ backward so that the jammed pieces of paper can be cleared.

### 3.7.5.3 PAPER JAMS AT THE REAR OUTPUT SLOT

To remove a jammed document from area C (at the rear document output slot), carefully pull the document outward to avoid ripping it as explained previously.



*Fig 3-16 Removing a Document from the Rear Output Slot*



## 4. AUTODIAGNOSTICS, SETUP AND SETTINGS

### 4.1 POWER-ON DIAGNOSTICS

At every power-on, besides the general reset, the printer runs an autodiagnosics cycle to check the efficiency of its parts.

After the autodiagnosics, if no faults have been revealed, the printer remains in READY condition (ON and READY LEDs lit on the console).

The table below indicates the meaning of the LEDs according to the type of failure detected during the autodiagnosics phase.

LED	ON	Others
Power supply assy failure	OFF	OFF
Board failure: - Eprom - ROM - Microprocessor	ON	OFF
Failure with: - Fuses - Drivers - Motors	ON	ON
Activation board failure	The motors do not control any movement	

## **4.2 PRINT TEST**

With the print test the operator can obtain a printout of the machine set-up.

The instructions to run the test are given in section 3.3 (off line tests).

## **4.3 MACHINE SET-UP**

The set-up environment is only to be accessed by the service engineer since many of the selectable parameters serve to personalize the machine or installed option and must not be changed. An incorrect intervention by the operator could cause faults on the printer.

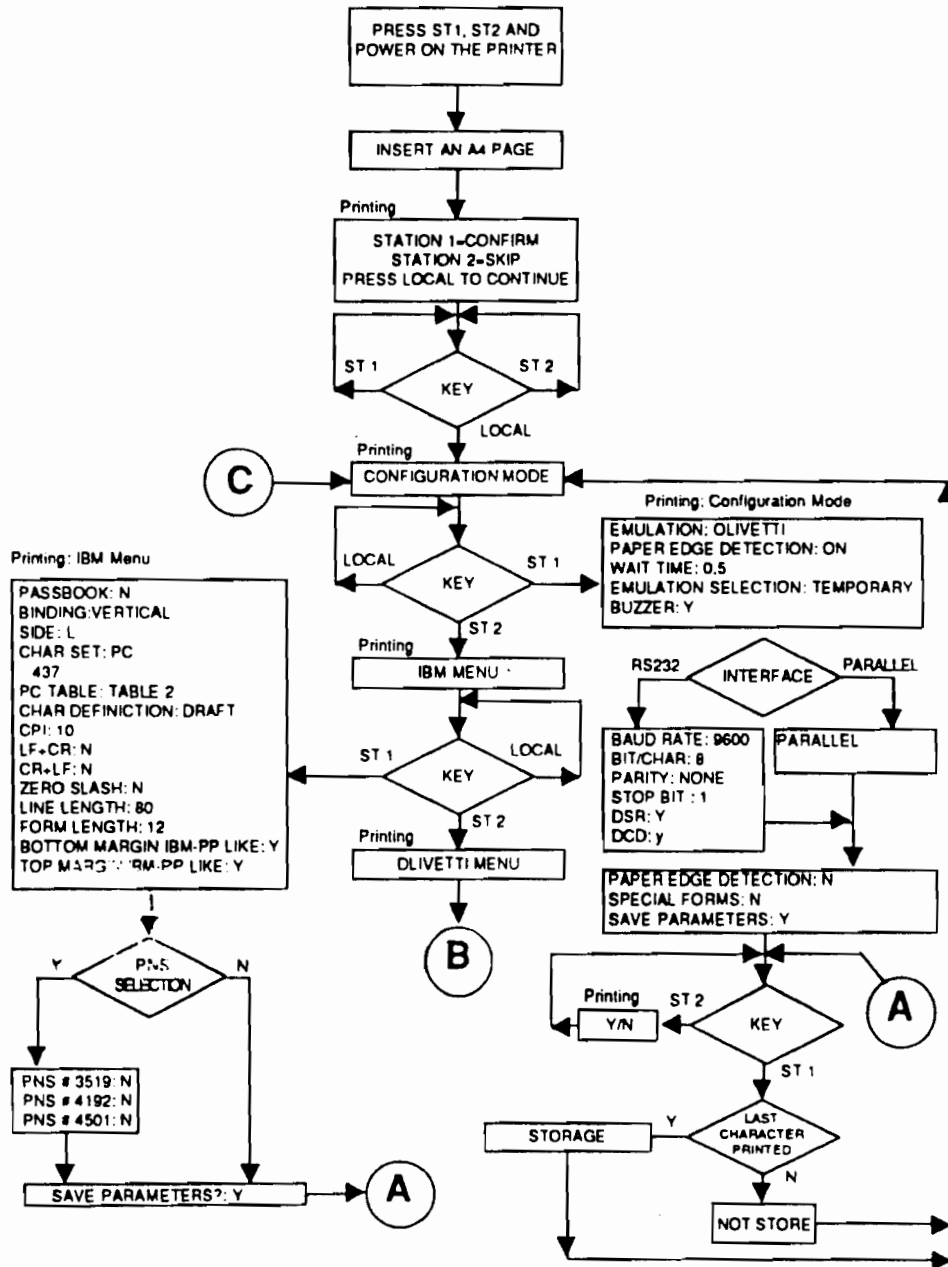
### **4.3.1 SET-UP ACTIVATION**

To enter the set-up environment, power off the machine and power on again keeping the ST1 and ST2 keys on the console pressed down.

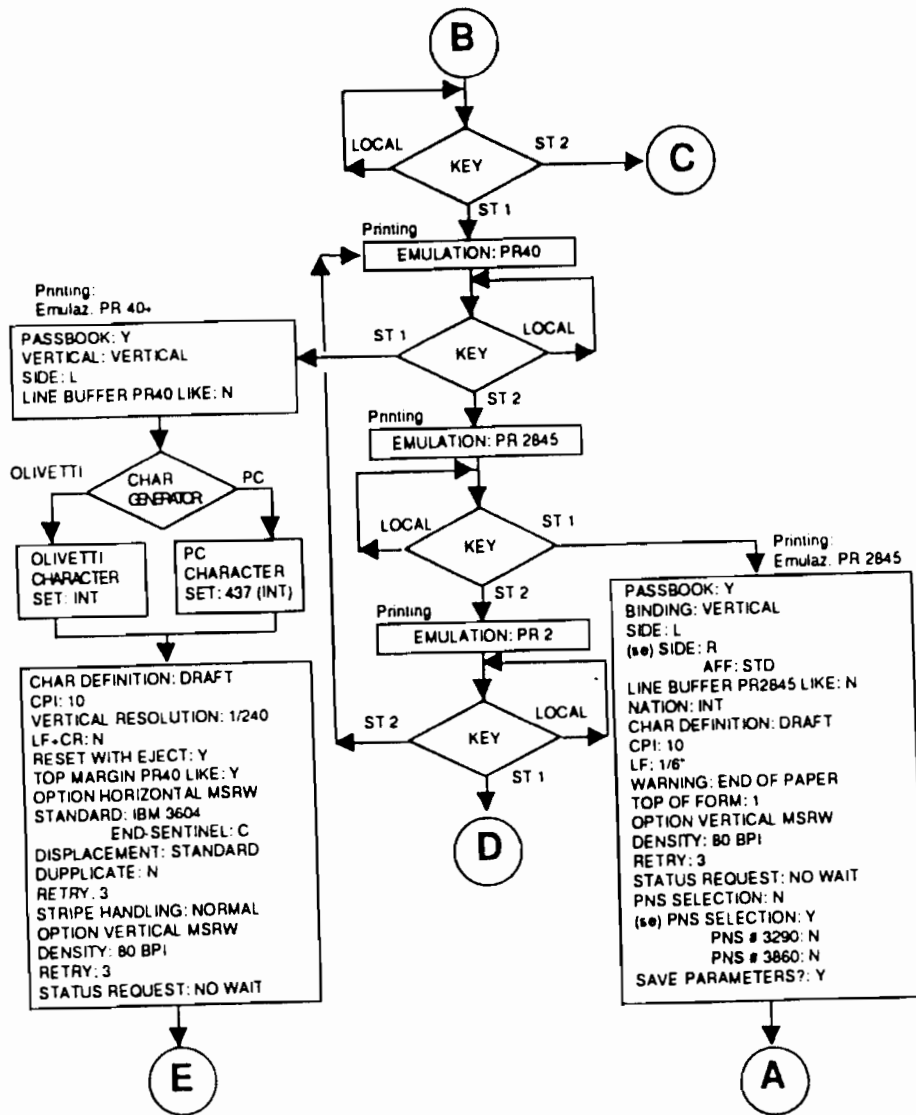
After the reset has been run, insert an A4 size page into the front infeed: the machine will print a line with the meanings of all the keys in this environment.

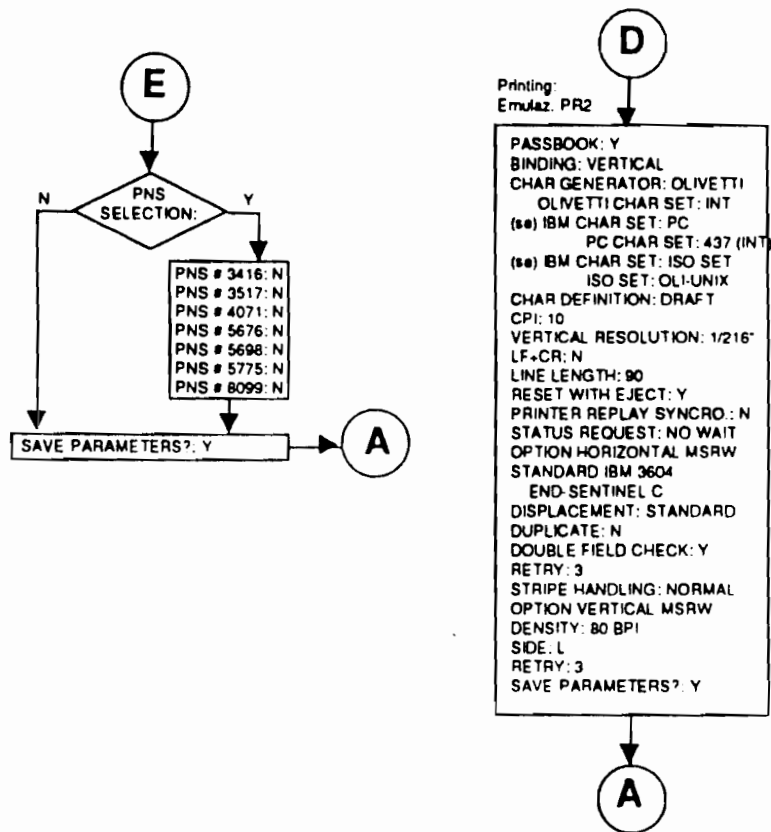
On the following pages there is a flow-chart that indicates the possibilities to enter into the various parts that form the set-up.

# SET-UP FLOW CHART









**Note:** In the flow chart menu the default values are given for parameters of options that can be installed on the machine.

## 4.3.2 CONFIGURATION PARAMETERS

This section lists the parameters to be found in the set-up, with the alternative settings and their meanings.

The default values are indicated in bold print.

### 4.3.2.1 CONFIGURATION MODE MENU PARAMETERS

EMULATION	IBM - <b>OLIVETTI</b>	Choice of code interpreter to be used.
PAPER EDGE DETECTION	OFF- <b>ON</b>	Enables/disables the photosensor that blocks the print job when a document is not present
WAIT TIME	<b>0,5</b> - 0,8 - 1.2	Wait time (in seconds) from the detection of the paper in the infeed to the start of automatic alignment.
EMULATION SELECTION	<b>TEMPORARY</b> PERMANENT	Saves the emulation change made on line in EEPROM.
BUZZER	Y - N	Activates/deactivates the acoustic signal.
INTERFACE	<b>RS 232</b>	Interface to connect to the system.
BAUD RATE	<b>9600</b> - 4800 - 2400 - 1200	Data transmission/receiving rate (bit).
BIT/CHAR	7 - <b>8</b>	Data format: 7 or 8 bits.
PARITY	<b>NONE</b> - ODD - EVEN	Presence/type of parity control: none, odd, even.
STOP BIT	1 - <b>2</b>	Number of stop bits.
DSR	Y - N	Data Set Ready managed/not managed by printer. Must be set as on the connected system.
DCD	Y - N	Data Carrier Detector managed/not managed by printer. Must be set as on the connected system.
PARALLEL		Only the Centronics interface is enabled.
PAPER EDGE DETECTION: N - Y		When enabled (Y) prevents the printing of lines longer than the sheet inserted. A paper bourage is generated in the Olivetti environment (ESC r 1).
SPECIAL FORMS: N - Y		When enabled (Y), every paper movement is performed with the print head outside the size of the inserted paper. In this way it is possible to use forms with the minimum paper specifications, avoiding any possible paper bourage.
SAVE PARAMETERS	Y - N	Saves (Y) or not (N) the selected arrangement in this set-up section.

### 4.3.2.2 IBM MENU PARAMETERS

PASSBOOK	Y - N	Indicates whether the printer is enabled (Y) or not (N) by default to process passbooks.
BINDING	HORIZ -VERT	Indicates whether the savings book in the printer is binded horizontally or vertically.
SIDE: L - R		Selecting R (Right) provides SW compatibility with the PR50 with right alignment. Selecting L (Left) provides SW compatibility with the PR50 with left alignment.
CHAR SET	PC - ISO	Character generator selection

(Only for CHAR SET = PC)

PC SET	DK/N	
	DK	
	210	GR
	220	E
	<b>437</b>	INT
	850	LATIN 1
	860	P
	862	IL
	864	ARABIC

(Only for CHAR SET = ISO)

ISO SET	OLI-UNIX
	<b>ISO 8859/1</b>
	ISO 8859/6

PC TABLE	TABLE 1 - <b>TABLE 2</b>	Selects the character generator table.
CHAR DEFINITION	LQ - <b>DRAFT</b>	Selection of print definition.
CPI	10 - 12 - 17.1	Selection of printing pitch, in characters per inch.
LF+CR	Y - N	Selects (Y) or (N) for automatic carriage return (CR) at every line feed command received (LF).
CR+ LF	Y - N	Selects (Y) or (N) for automatic line feed (LF) at every carriage return command received (CR).
ZERO SLASH	N - Y	Enables/disables the printing of slashed zero.

LINE LENGTH	80 - 90	Selects the maximum length of the printed line as a number of characters (10 cpi).
FORM LENGTH	11 - 12	Selects the maximum length of processable documents in inches.
BOTTOM MARGIN IBM-PP LIKE	Y - N	Selects the type of page bottom margin (BOF) for the processed document. If the parameter is Y, the bottom margin is 13.7 mm; if the parameter is N the margin is 4.23 mm.
TOP MARGIN IBM-PP LIKE	Y - N	Selects the type of page top margin (TOF) for the processed document. If the parameter is Y, the top margin is 4.23 mm for documents and 7.4 mm for passbooks; if the parameter is N, the margin is between 4.3 and 30 mm (defined by the set-up described in section 4.4.1) for documents and 7.4 mm for passbook.
PNS SELECTION:	N - Y	Selecting (Y) allows access to the PNS selection menu in the IBM environment.
PNS SELECTION:	N - Y	
PNS # 3519:	N - Y	Enables the ESC' (n) command for passbook (n=D or E or F or G) or document (n=@ or A or B or C) selection.
PNS # 4192:	N - Y	If enabled upon reception of a Form Feed, the document is ejected.
PNS # 4505:	N - Y	Selects a 1/5" spacing.
SAVE PARAMETERS	Y - N	Stores (Y) or not (N) the arrangement selected in this set-up section.

### 4.3.2.3 OLIVETTI PR 2 MENU PARAMETERS

PASSBOOK	Y - N	Indicates whether printer is enabled (Y) or not (N) by default to process passbooks.
BINDING:	VERTIC.-HORIZONT.	Indicates whether the passbook in the printer is binded horizontally or vertically.
CHAR GENERATOR	<b>OLIVETTI -</b> IBM/PC	Character generation selection.

---

(Only for CHAR SET = OLIVETTI)

#### OLIVETTI CHAR SET:

INT	International
USA	USA-ASCII
D	Germany
P	Portugal
E	Spain
E2	Spain 2
DK/N	Denmark/Norway
F	France
I	Italy
S/SF	Sweden/Finland
CH	Switzerland
U.K.	United Kingdom
YU	Yugoslavia
IL	Israel
GR	Greece
CDN	Canada BOM
STD 31	Standard 31
SDC	SDC
TR	Turkey
ARABIC	Arabic

IBM CHAR SET PC - ISO

These are the same character sets as the ones listed in the IBM menu.

CHAR DEFINITION	<b>DRAFT</b> - LQ - OCR-A - OCRB	Print definition selection.
CPI	5 - <b>10</b> - 12 - 15 - 16,6 - 17,1	Selection of printing pitch, in characters per inch (pci).
VERTICAL RESOLUTION	1/216" - <b>1/240"</b>	Vertical resolution in fractions of an inch.
LF+CR	Y - <b>N</b>	Selects (Y) or (N) for automatic carriage return (CR) at every line feed command received (LF).
LINE LENGTH	<b>90</b> - 94	Selects the maximum print line length, measured at 10 characters per inch.
RESET WITH EJECT	Y - <b>N</b>	Sets (Y) or not (N) the automatic ejection of the document in the machine every time the printer makes a general reset.
PRINTER REPLY SYNCHRONIZED	Y - <b>N</b>	DSR (Data Send Ready) management in transmission.
STATUS REQUEST:	<b>NO WAIT</b> - WAIT	Determines the timing of the status reply upon reception of an ESC j command. By selecting <b>NO WAIT</b> , the reply will be provided as soon as possible and simultaneously with the execution of a print job or paper movements. By selecting <b>WAIT</b> , the status reply will be provided at the end of the print job.

---

Parameters set only if the horizontal magnetic unit is present

OPTION HORIZONTAL MSRW		Informs that the option is installed. If the MICR option is present, + MICR will be written alongside ".....MSRW".
------------------------	--	--

---

(Only with STANDARD = IBM 3604)

STANDARD	DIN/ISO - ANSI - <b>IBM 3604</b>	Sets magnetic standard.
END- SENTINEL	<b>C</b> - F	Sets the closing code.

DISPLACEMENT	<b>STANDARD</b> - +10 - +20	Sets the magnetic strip position in mm.
DUPLICATE	Y - N	Sets or not the field duplication.
DOUBLE FIELD CHECK	Y - N	Sets or not the double field check.
RETRY	3 - 1	Indicates the number of read attempts before indicating an error.
STRIPE HANDLING	<b>NORMAL</b> - FAST	Set a fast or normal magnetic stripe handling.

---

(Only with vertical magnetic option)

OPTION VERTICAL MSR		Inform that the option is installed.
DENSITY	<b>80 BPI</b> - 160 BPI	Sets the density of data impact in bits per inch.
SIDE	L - R	This selection can only be made with the vertical magnetic unit option installed. Allows the HW management of the option.
RETRY	3 - 1	Indicates the number of read attempts before indicating an error.
SAVE PARAMETERS	Y - N	Stores (Y) or not (N) the arrangements selected in this set-up section.



#### 4.3.2.4 OLIVETTI PR 40+ MENU PARAMETERS

PASSBOOK	Y - N	Indicates whether the printer is enabled (Y) or not (N) to handle passbooks by default.
BINDING:	HORIZ - VERT	Indicates whether the passbook fed into the printer is bound horizontally or vertically.
SIDE: L - R		Selecting R (Right) provides SW compatibility with the PR50 with right alignment. Selecting L (Left) provides SW compatibility with the PR50 with left alignment. This selection also allows the HW management of the right or left vertical magnetic unit.
LINE BUFFER PR40 LIKE	Y - N	Sets the reception buffer size like the one on the PR 40 (1 Kbyte) or to 8 Kbytes.
CHAR GENERATOR	OLIVETTI - PC	Selects the character generator.

---

(Only for CHAR GENERATOR = OLIVETTI)

#### OLIVETTI CHAR SET:

INT	International
USA	USA-ASCII
D	Germany
P	Portugal
E	Spain
E2	Spain 2
DK/N	Denmark/Norway
F	France
I	Italy
S/SF	Sweden/Finland
CH	Switzerland
U.K.	United Kingdom
YU	Yugoslavia
IL	Israel
GR	Greece
CDN	Canada BOM
STD 31	Standard 31
SDC	SDC
TR	Turkey

---

(Only for CHAR SET = IBM/PC)

**PC CHAR SET:**

437 (INT)  
850 (LATIN 1)  
860  
862  
864  
OLI-UNIX  
ISO 8859/1  
ISO 8859/6  
DK/N  
DK  
210  
220

---

CHAR DEFINITION	<b>DRAFT - NLQ - OCRA - OCRB</b>	Select the print definition.
CPI	5 - 10 - 12 - 16,6	Selects the print pitch, expressed in characters per inch (cpi).
VERTICAL RESOLUTION	1/216" - 1/240"	Vertical resolution, expressed in a fraction of an inch.
LF+CR	Y - N	Enables (Y) or not (N) the execution of an automatic Carriage Return (CR) each time a Line Feed command is received (LF).
RESET WITH EJECT	Y - N	Enables (Y) or not (N) the automatic ejection of a document present in the printer at each general reset.
TOP MARGIN PR40 LIKE	Y - N	TOF management with a fixed value (PR 40) or with an adjustable one.

---

(Only if the horizontal magnetic unit option is present)

**OPTION HORIZONTAL MSRW**

Informs that the option is installed. If the MICR option is present, + MICR will be written alongside ".....MSRW".

(Only for STANDARD = IBM 3604)

---

STANDARD	<b>DIN/ISO - ANSI - IBM 3604</b>	Sets the magnetic standard.
----------	--------------------------------------	-----------------------------

---

END-SENTINEL	C - F	Sets the end code.
DISPLACEMENT	STANDARD - +10 - +20	Sets the position of the magnetic stripe.
DUPLICATE	Y - N	Sets the printer for field duplication.
RETRY	3 - 1	Sets the number of read attempts before an error condition is signalled.
STRIPE HANDLING	NORMAL - FAST	Allows the normal or fast handling of the magnetic stripe.

(Only if the vertical magnetic unit is present)

OPTION VERTICAL MSR		Informs that the option is installed.
DENSITY	80 BPI - 160 BPI	Sets the data density in bits per inch.
RETRY	3 - 1	Indicates the number of read attempts before an error condition is signalled.

**Note:** If the right vertical magnetic unit option is present, SIDE = R must be selected so that the option can be handled correctly.

STATUS REQUEST:	NO WAIT - WAIT	Defines the timing of the status reply upon reception of an ESC j command. By selecting NO WAIT, the reply <b>will</b> be provided as soon as possible and simultaneously with a print job execution or with paper movement. By selecting WAIT, the status reply will be provided at the end of the print job.
PNS SELECTION:	N - Y	Selecting (Y) grants access to the PNS selection menu in the Olivetti PR40+ environment.

(If) PNS SELECTION: Y

PNS # 3416:	N - Y	Enables or disables a check on the magnetic stripe's two recorded fields.
PNS # 3517:	N - Y	By selecting Y the selection "CPI 15: y/n" will appear. With this selection, the default spacing at power up will be 15 cpi, otherwise it will correspond to the value set for the CPI parameter. Enabling this PNS will activate the ESC a 3 command for the SW selection of a 15 cpi spacing.
(If) PNS # 3517: CPI 15:	Y N - Y	15 cpi pitch selection. By selecting "Y" the spacing at power up will be 15 cpi which becomes priority with respect to the value set for the standard "CPI" parameter mentioned earlier. In this case, during SELF-TEST printing the standard "CPI" parameter will no longer be printed.
PNS # 4071:	N - Y	Enables printing at 17.14 cpi with the ESC > and ESC a 8 commands. The ESC a (n) also allows to selection of 10, 12, 15, 16.6 and 17.14 cpi pitches.
PNS # 5676:	N - Y	Enables the following commands and functions: ESC }- for form width measurement. ESC sp B for document status request and the related reply ESC B. ESC a (11) <sub>D</sub> for a 5 cpi BS (Back Space) selection. Left margin of 2 mm.
PNS # 5698:	N - Y	PNS for Spain Tarragona which includes: <ol style="list-style-type: none"><li>1. ESC T with the management of the lower default TOF value (43/240" or 38/216") instead of 70/240" or 63/216".</li><li>2. Esc p relating to the reply of the secondary identifier with MICR management.</li><li>3. ESC Y B k1 k2 for MICR setting.</li><li>4. ESC } r for MICR reads.</li><li>5. The requests relating to 15 CPI, 17.14 CPI printing and magnetic stripe FAST reads of the magnetic stripe are selectable via setup with other PNSes or with standard features.</li><li>6. The elimination of the mechanical cycles after ESC o and/or Olivetti &lt;-&gt; IBM emulation changes are already embodied in the standard FW.</li></ol>
PNS # 5775:	N - Y	Enables the use of commands for the management of the MICR option.
PNS # 8099:	N - Y	Enables the issue of synchronized replies from the host through the DSR signal.
SAVE PARAMETERS?:	Y - N	Stores (Y) or not (N) the settings selected in this section of the setup program.

### 4.3.2.5 OLIVETTI PR 2845 MENU PARAMETERS

PASSBOOK	Y - N	Indicates whether the printer is enabled (Y) or not (N) by default to handle passbooks.
BINDING	HORIZ - VERT	Indicates whether the passbook handled is bound horizontally or vertically.
SIDE: L - R		Selecting R (Right) provides SW compatibility with the PR2845 with right-hand alignment. Selecting L (Left) provides SW compatibility with the PR2845 with left-hand alignment.
(se) SIDE R AFF <b>STD</b> - USA		Selects the print line width.
LINE BUFFER PR2845 LIKE	Y - N	Sets the reception buffer length like the PR 2845 (512 Byte) or at 8 Kbytes.
NATION	<b>INT</b> <b>USA</b> <b>D</b> <b>P</b> <b>E</b> <b>E2</b> <b>DK/N</b> <b>F</b> <b>I</b> <b>S/SF</b> <b>CH</b> <b>U.K.</b> <b>YU</b> <b>IL</b> <b>GR</b> <b>CDN</b> <b>STD 31</b> <b>SDC</b> <b>TR</b> <b>IS</b>	International USA-ASCII Germany Portugal Spain Spain 2 Denmark/Norway France Italy Sweden/Finland Switzerland United Kingdom Yugoslavia Israel Greece Canada BOM Standard 31 SDC Turkey Island
CHAR DEFINITION	<b>DRAFT - NLQ</b>	Selects the print definition.
CPI	<b>10 - 12</b>	Selects the print pitch in characters per inch (cpi).
LF	<b>1/5" - 1/6"</b>	Selects the line feed in fractions of an inch.
WARNING:	<b>END OF PAPER</b> <b>- PHOTO SENS.</b>	Signals the end of journal roll or the TOP photosensor covered.
TOP OF FORM	<b>1 - 2</b>	Selects either the first or second printable line.

(Only if the vertical magnetic option is present)

OPTION VERTICAL MSRW		Informs when the option is installed
DENSITY	80 BPI - 160 BPI	Sets data density.
RETRY	3 - 1	Indicates the number of read retries before the error condition is signalled.

**Note:** If the right vertical magnetic unit option is present, SIDE = R must be selected so that the option can be correctly handled.

---

STATUS REQUEST	NO WAIT - WAIT	This parameter determines the timing of the status reply upon reception of an ESC j command. By selecting NO WAIT, the reply will be provided as soon as possible and simultaneously with the execution of print or paper movement commands. By selecting WAIT, the status reply will be provided at the end of the print job.
PNS SELECTION	N - Y	Selecting (Y) gives access to the PNS selection menu in the Olivetti 2845 environment.
PNS # 3290	N - Y	Enables the conversion of all the characters of the ASCII table to those of column 3X (numeric column).
PNS # 3860	N - Y	Reduces the number of trailing "0" on the vertical magnetic stripe recording.
SAVE PARAMETERS	Y - N	Defines whether to store (Y) or not (N) the settings made in this Setup section.

## 4.4 ADJUSTING THE PHOTOSENSORS

The printer's photosensors are adjusted at the factory. However, a change of the electrical characteristics of the photosensors used or the use of non-standard paper may require that the photosensors be readjusted at the customer's site.

All the photosensors in the printer need adjusting. The following are installed:

- Paper presence photosensors.  
These consist of two LEDs and two photoreceivers that are the first to detect the loading of a document through the front insertion slot. The ray of light is transmitted by fibre optics.
- Paper front alignment photosensors.  
These are included in the same group as the paper presence photosensors and are indicated in this manual as front photosensor group.  
The paper front alignment photosensors check the alignment of the paper before it reaches the print head. They consist of four LEDs and four photoreceivers, all connected through fibre optics.
- Autoborder photosensor.  
Fitted on the print head, this photosensor detects the presence of paper so that the position of the first print column can be measured. This photosensor also makes it possible to check the print interruption or carriage return functions in case the paper is narrower than the print line length value sent by the system. This photosensor also resets the print carriage.
- Paper rear alignment photosensor.  
Consists of a LED and photoreceiver connected through a fibre optic. This photosensor checks for the presence of paper at the rear output slot.

The figure on the next page shows the location of the individual photosensors on the printer.



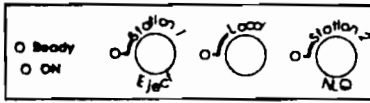


To adjust the photosensors, proceed as follows:

1. Power on the printer with the cover open and while holding down the three console keys.
2. Wait for the acoustic signal indicating that the printer has switched to the adjustment procedures.
3. Manually move the print head to the left-hand side and close the cover.
4. Press the "Station 1" key to enter into the photosensor and alignment adjustment menu.
5. Press the "Station 1" key to enter into the photosensor adjustment menu.
6. After this phase the sensors have stored the current ratings without the paper being loaded and the paper feed motor will begin to turn waiting for a form to be inserted.
7. Insert the adjustment mylar in the front slot and press the "Station 2" key. The sheet will be completely inserted to cover all the photosensors, and the current will be measured in the paper present condition. Instead of the sheet of mylar, an A4 size sheet can be used; in this case the adjustment values will differ and will be less exact with respect to the adjustment made using the mylar.

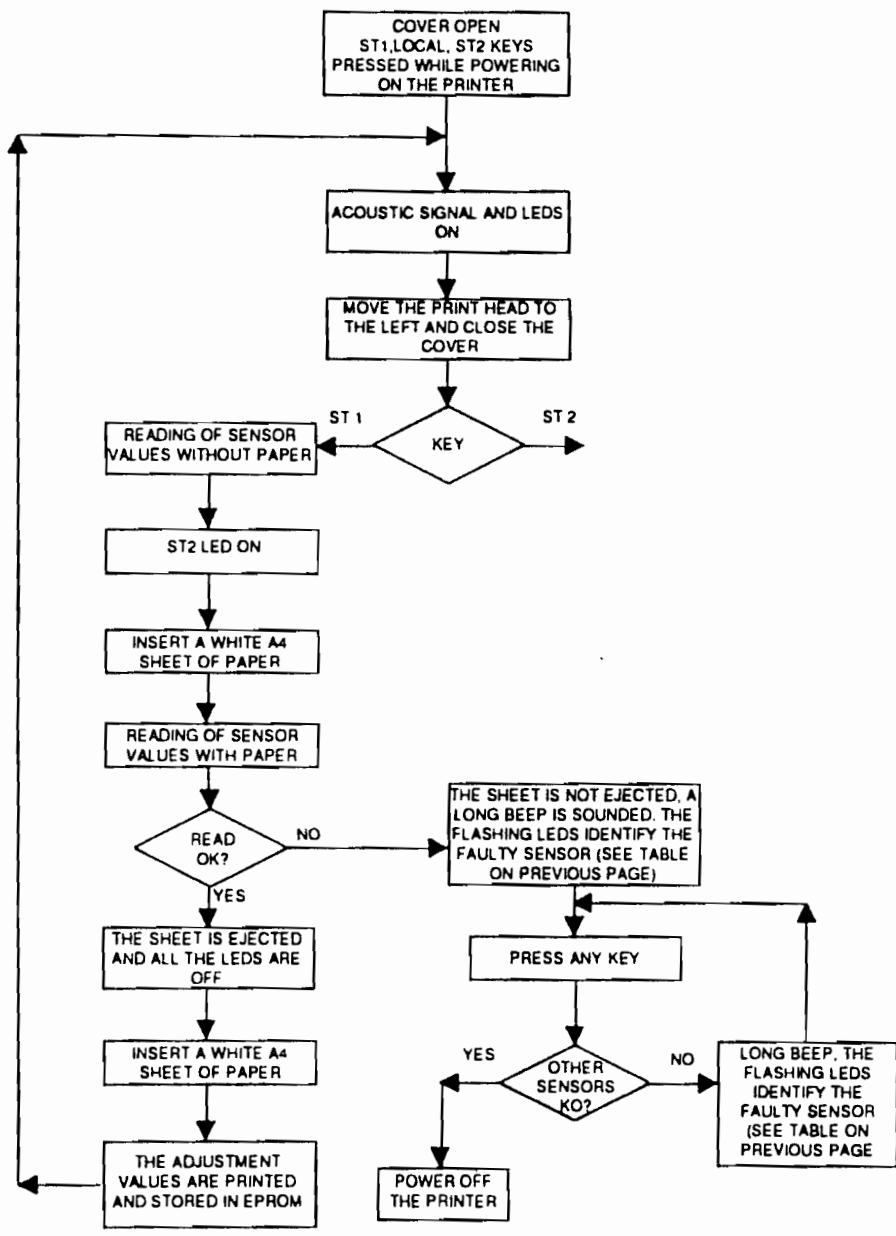
If there are no failures the console LEDs will remain off and the sheet will be automatically ejected. Inserting the sheet again will enable the values read and preselected for each single photosensor to be printed. If the adjustment procedure was not successful, the faulty photosensor will be identified through the different LED lighting patterns. Pressing any key on the console will identify any other faulty photosensor.

In case the adjustment did not end successfully, also the other adjustments or readings may not be executed. In this case power off the printer and try again. If the adjustments were successful, the printer will automatically return to the initial overall environment allowing the selection of any adjustment procedure.



		X	X	Photo 1 - Front paper alignment
		X	X	Photo 3 - Front paper alignment
	X		X	Photo 2 - Front paper alignment
	X		X	Photo 4 - Front paper alignment
	X	X	X	Photo 1 - Front paper presence
	X	X	X	Photo 2 - Front paper presence
X			X	Carriage reset print head photosensor
X			X	Paper edge read print head photosensor
			X	Rear paper presence photosensor

The flow chart on the next page illustrates the procedure just explained.



If adjustment ended successfully, insert an A4 sheet of paper in order to print the adjustment values. The following table indicates the parameters to be checked.

Photosensor	1	2	Aver. Value (mV.)	Current (mA.)
	No paper (mV.)	Paper (mV.)		
Photo 1, front paper alignment	XXXX	XXXX	XXXX	XX
Photo 2, front paper alignment	XXXX	XXXX	XXXX	XX
Photo 3, front paper alignment	XXXX	XXXX	XXXX	XX
Photo 4, front paper alignment	XXXX	XXXX	XXXX	XX
Photo 1, front paper present	XXXX	XXXX	XXXX	XX
Photo 2, front paper present	XXXX	XXXX	XXXX	XX
Carriage reset head photo	XXXX	XXXX	XXXX	XX
Paper edge head photo	A XXXX	B XXXX	XXXX	XX

3

**Parameters to check**

1. Value  $\geq$  3800
2. Value  $\leq$  1500

Perform a further check by inserting a form with a check format code 152136J at the two sides and center of the insertion slot and with its shortest side parallel to the axis of the photosensors. Check for correct operation.

#### 4.4.1 ADJUSTING BIDIRECTIONAL PRINTING ALIGNMENT

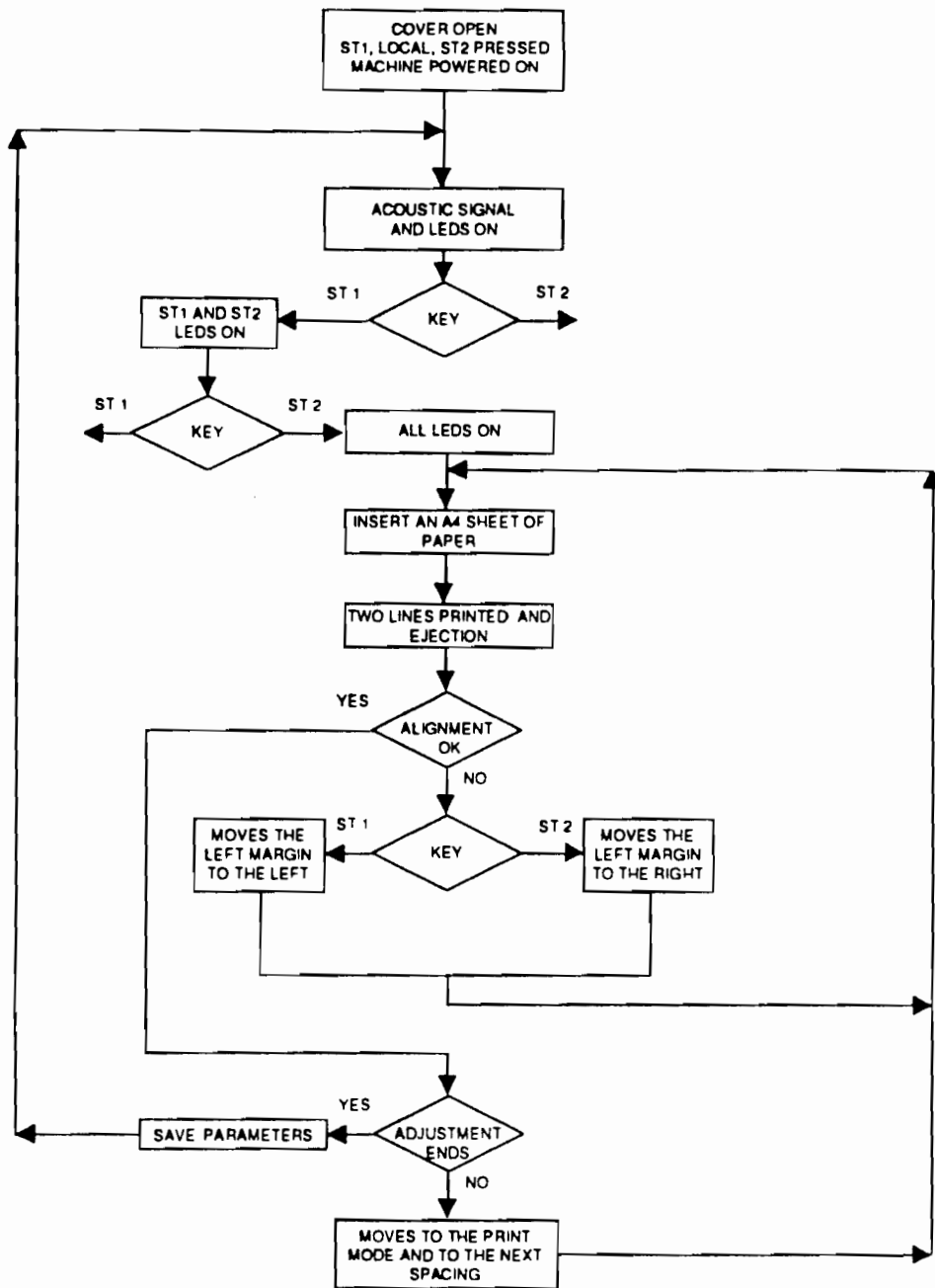
Bidirectional printing quickens printer operation but reduces print quality if the rows written from left to right and viceversa are not aligned correctly. Bidirectional printing alignment can be optimized by means of an adjustment procedure which must be made for each of the following print modes:

- Very High Speed Draft
- High Speed Draft
- Draft
- Near letter quality
- Letter quality

Proceed as follows to adjust the alignments:

1. Power on the printer with the cover open and while holding down the three console keys.
2. Wait for an acoustic signal to indicate that the printer has switched into the adjustment mode and close the printer cover.
3. Press the "Station 1" key.
4. Press the "Station 2" key.
5. The three console keys are activated after this phase. The "Station 1" key can be used to anticipate printing while "Station 2" can be used to delay printing.
6. Pressing the "Station 1" and "Station 2" keys before step 5, all the default values theoretically near the correct ones will be stored for all print modes.
7. Insert an A4 sheet of paper into the front slot to check the alignment during the Very High Speed Draft print mode.
8. Press "Station 1" and/or "Station 2" to adjust the alignments.
9. Repeat steps 7. and 8. until all the adjustments are complete.
10. Press the "Local" key to permanently store the alignment value for the current print mode and to automatically mode to the next adjustment.

Adjustment ends when all the print modes are completed or by simultaneously pressing all three console keys. In both cases the printer will switch to the main menu.



**Note:** The printer automatically switches to all modes and spacings.

#### 4.4.2 ADJUSTING THE TOF OF FORM (TOF)

This adjustment sets the distance between the document's TOF and the print print line.

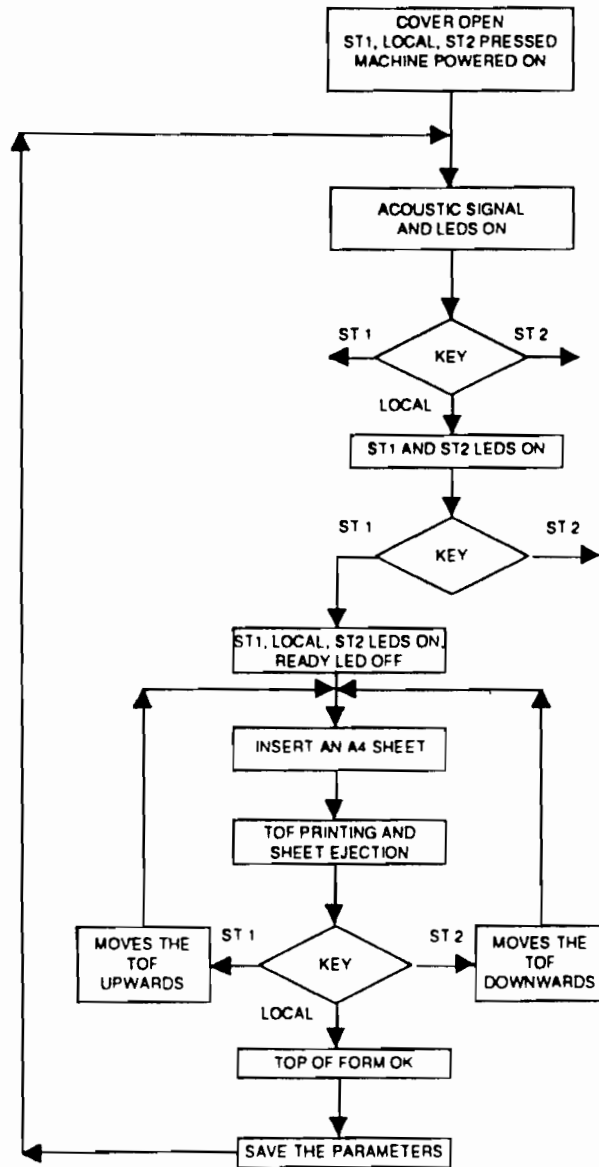
The adjustment can only be activated if the "TOP MARGIN PR40 LIKE" parameter in the PR40+ emulation setup has been set to "N". This selection is always active for the PR 2 emulation.

A value between 0 and 30 mm can be set.

Proceed as follows to make this adjustment:

1. Power on the printer with its cover open and while holding down the three console keys.
2. Wait for an acoustic signal to indicate that the printer has switched into the adjustment procedure and close the cover.
3. Press the "Local" key.
4. Press the "Station 1" key.
5. The three console keys are activated after this phase. The "Station 1" key can be used to reduce the TOF while "Station 2" can be used to increase the TOF.
6. Insert an A4 sheet of paper into the front slot to check the status of the current TOF. This check is made by printing a specific test. If the current TOF value is too high, printing may occur off the sheet of paper.
7. Press "Station 1" and/or "Station 2" to decrease or increase the TOF.
8. Repeat steps 6. and 7. until the adjustments are completed.
9. Press the "Local" key to permanently store the TOF and to automatically move on to the next adjustment.

Provided below is the flow chart of this alignment.





### 4.4.3 ADJUSTING THE LEFT PRINT MARGIN

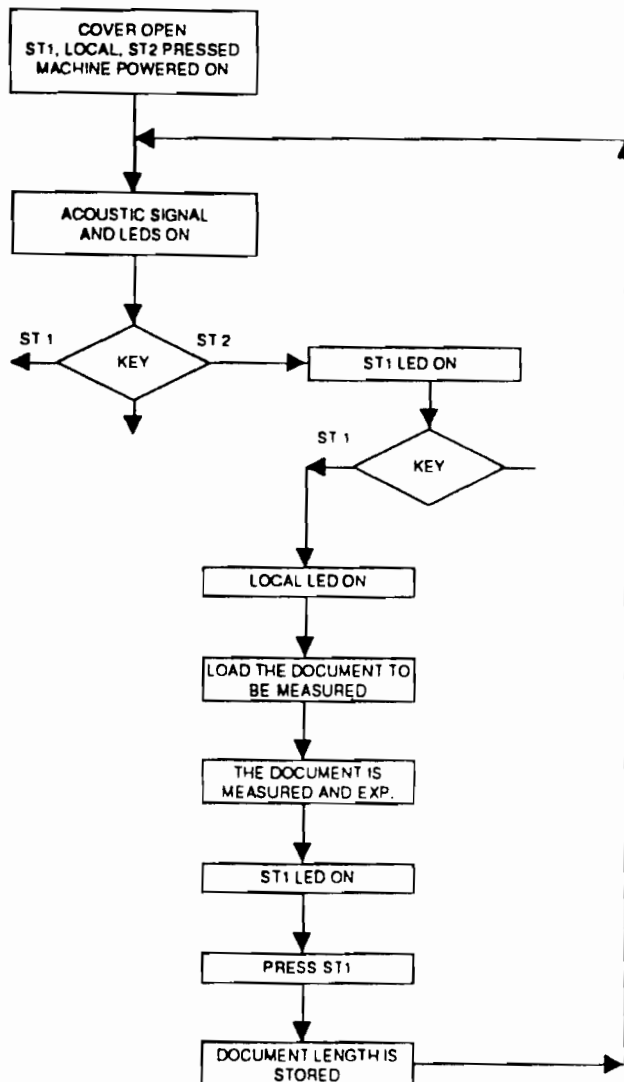
This adjustment sets the distance between the left edge of the document and the first print character.

A value between 0 and 27 mm can be set.

Proceed as follows to make this adjustment:

1. Power on the printer with its cover open and while holding down the three console keys.
2. Wait for an acoustic signal to indicate that the printer has switched into the adjustment mode and close the cover.
3. Press the "Local" key.
4. Press the "Station 2" key.
5. The three console keys are activated after this phase. Pressing the "Station 1" key will reduce the left margin while "Station 2" will increase this margin.
6. Insert an A4 sheet of paper into the front slot to check the status of the current left margin. This check is made through a specific tests that prints the current left margin.
7. Press "Station 1" and/or "Station 2" to move the left margin further to the left or right.
8. Repeat steps 6. and 7. until the adjustment is completed.
9. Press the "Local" key to permanently store the left margin and to automatically move on to the next adjustment.

Provided below is the flow chart of this adjustment.



#### 4.4.4 MEASURING THE LENGTH OF THE DOCUMENT

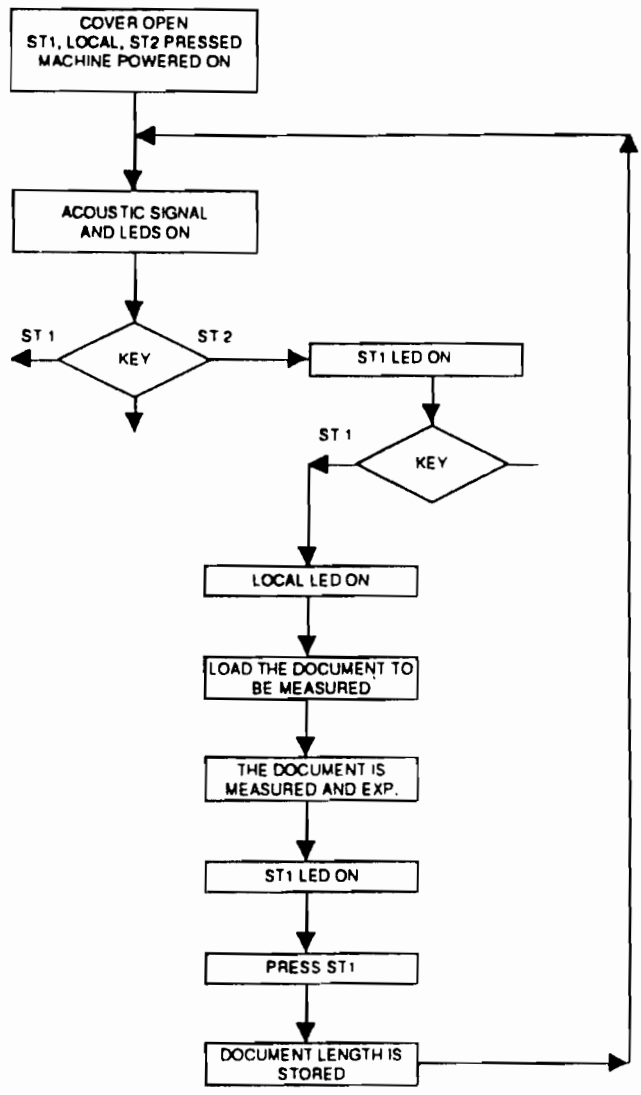
This adjustment sets the length of the document.

The document length measurement procedure makes it possible to select a fast stripe handling (STRIPEHANDLING = FAST) in machines with a horizontal magnetic unit and running the PR 40+ emulation.

Proceed as follows to make this adjustment:

1. Power on the printer with its cover open and while holding down the three console keys.
2. Wait for an acoustic signal to indicate that the printer has switched into the adjustment mode and close the cover.
3. Press the "Station 2" key.
4. After this phase only the "Station 1" will be active and can be used to start form length reading.
5. Insert an A4 sheet of paper in the insertion slot and press the "Station 1" key. The sheet will be automatically inserted and ejected.
6. Repeat step 5 if necessary.
7. Press the "Local" key to permanently store the form length value measured and to move on to the next adjustment.

Provided below is the flow chart of this adjustment.



#### 4.4.5 HORIZONTAL MAGNETIC UNIT OPTION ADJUSTMENT - SKEW AND SIGNAL AMPLITUDE CONTROL

This adjustment optimizes the operation of the horizontal magnetic unit option. The printer must be powered on and in the magnetic stripe read mode (line command).

The following conditions are to be checked:

- Correct orthogonality of the magnetic head that allows to obtain a signal similar to the one indicated in the "Skew" figure, where the spread must be 0.4 max.
- Amplitude of the signal read must be uniform and of a value no less than 4 V peak-to-peak. The signal displayed must be similar to the one indicated in the "Jitter" figure.

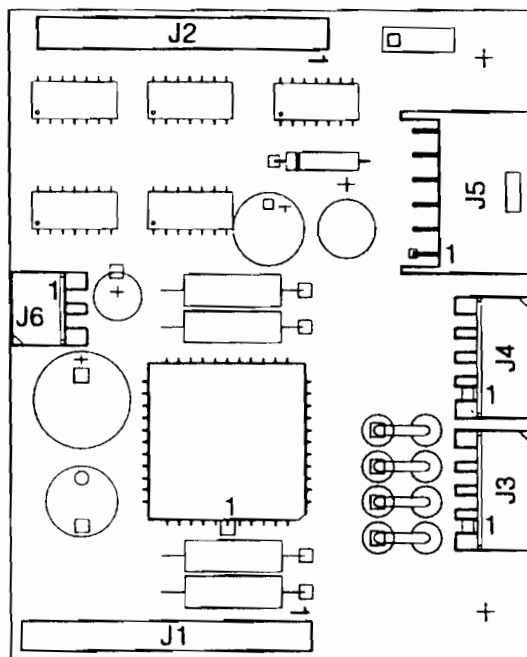


Fig. 4-2 Board View

Proceed as follows using an oscilloscope equipped with memory:

- Connect the oscilloscope ground to pin 2 (GND) and the probe signals to pin 1 (OUT2) of connector J6 on the PR2MAGN board.
- Insert the "Amplitude and Skew Sample" chart code 751884Z from the Skew Control side. Record the signal read when the head moves from left to right. The signal recorded must not have a spread greater than 0.4 V. No action needs to be undertaken.
- Insert the "Amplitude and Skew Sampe" chart code 751884Z from the Jitter/Ampl side. Record the signal read when the head moves from left to right. If the signal recorded does not reach the value of 0.4 V, the head assembly needs to be replaced.

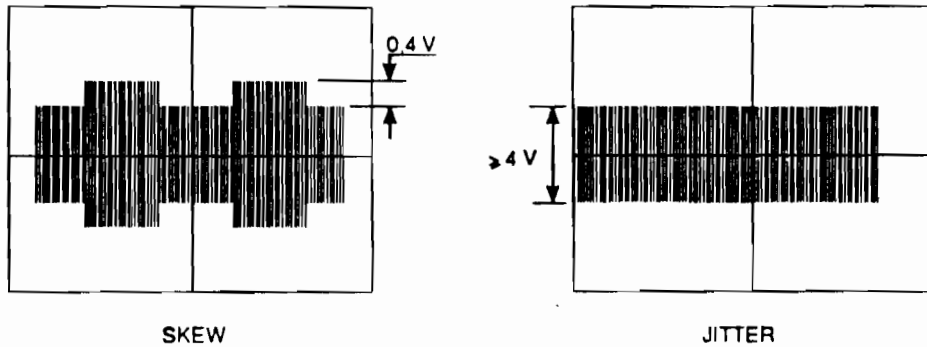


Fig. 4-3

#### 4.4.6 ADJUSTING THE VERTICAL MAGNETIC UNIT OPTION - SKEW AND SIGNAL AMPLITUDE CONTROL

This adjustment optimizes the operation of the horizontal magnetic unit option. The printer must be powered on and in the magnetic stripe read mode (line command).

The following conditions are to be checked:

- Correct orthogonality of the magnetic head that allows to obtain a signal similar to the one indicated in the "Skew" figure, where the spread must be 0.4 max.
- Amplitude of the signal read must be uniform and of a value no less than 4 V peak-to-peak. The signal displayed must be similar to the one indicated in the "Jitter" figure.

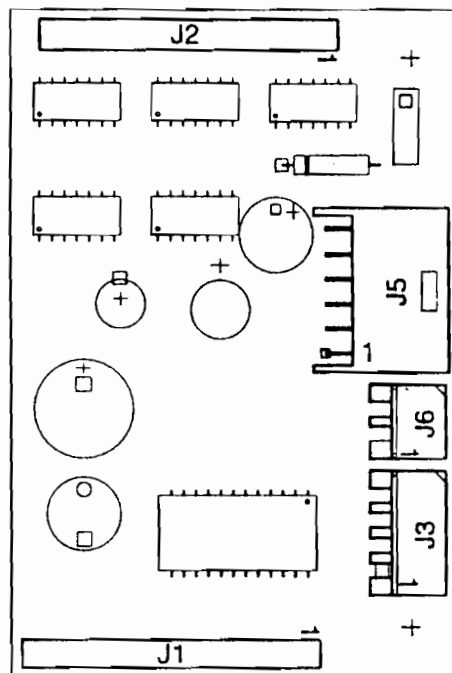


Fig. 4-4 Board View

Proceed as follows using an oscilloscope equipped with memory:

- Connect the oscilloscope ground to pin 2 (GND) and the probe signals to pin 1 (OUT1) of connector J6 on the PR2VER board.
- Insert the "Amplitude and Skew Sample" chart code 751883Y from the Skew Control side. Record the signal read during chart insertion. The signal recorded must not have a spread greater than 0.4 V. No action needs to be undertaken.
- Insert the "Amplitude and Skew Sample" chart code 751883Y from the Jitter/Ampl side. Record the signal read during chart insertion. If the signal recorded does not reach 4 V, the assembly needs to be replaced.

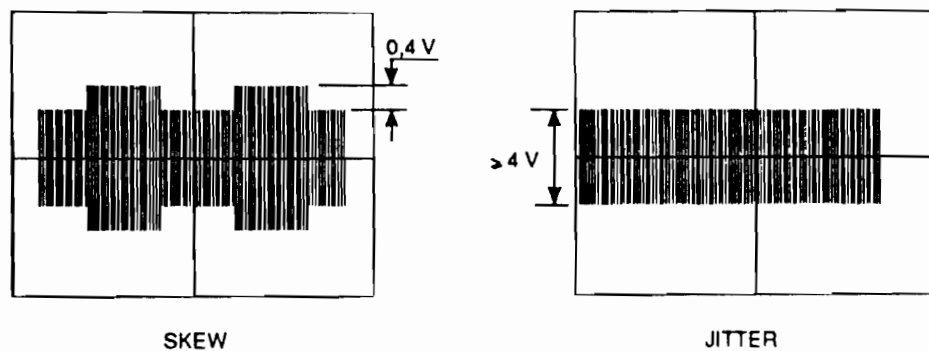


Fig. 4-5



#### 4.4.7 ADJUSTING THE CHECK READER ON THE PR 2

The check reading feature in the CMC7 format on the PR2 is made possible by means of the PR2MIMAG board (micr + horizontal magnetic unit)

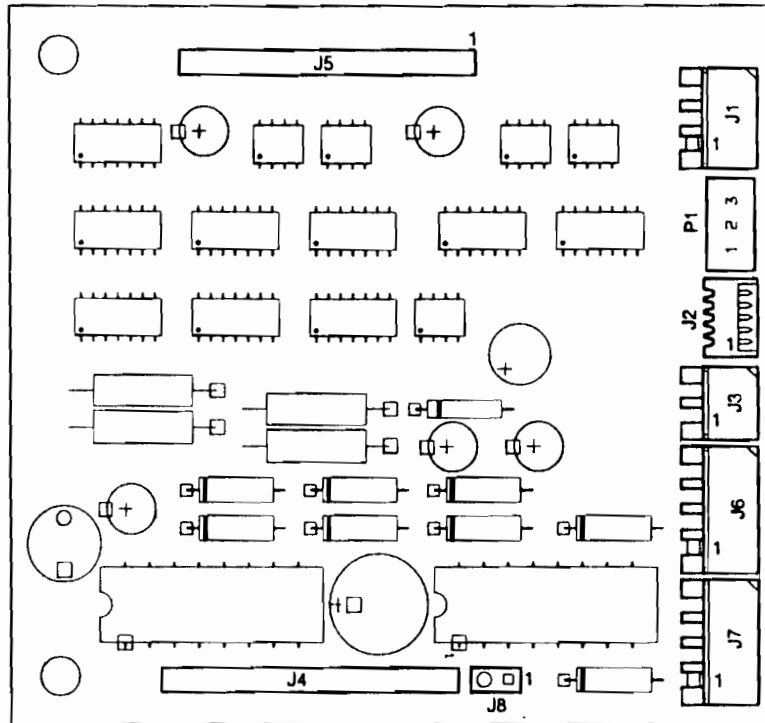


Fig. 4-6

The MICR circuit adjustment is made using a sample check with the < character, in E13B format, called ON US and with code 474245A.

The ON US character is printed using magnetic ink with a percentage of oxide which can differ according to the sample check used and which is indicated on the check.

The voltage used for adjustment differs according to the percentage of oxide indicated on the sample check and will be 1 V for 100%; 0.9 V for 90%; 1.1 V for 110%.

When using a check with a percentage of 92%, adjustment consists of using potentiometer P1 to adjust the voltage between J1 (1) and J1 (2), making sure that the average between the two positive voltage peaks generated by the print head is 0.92 V as shown in the following figure:

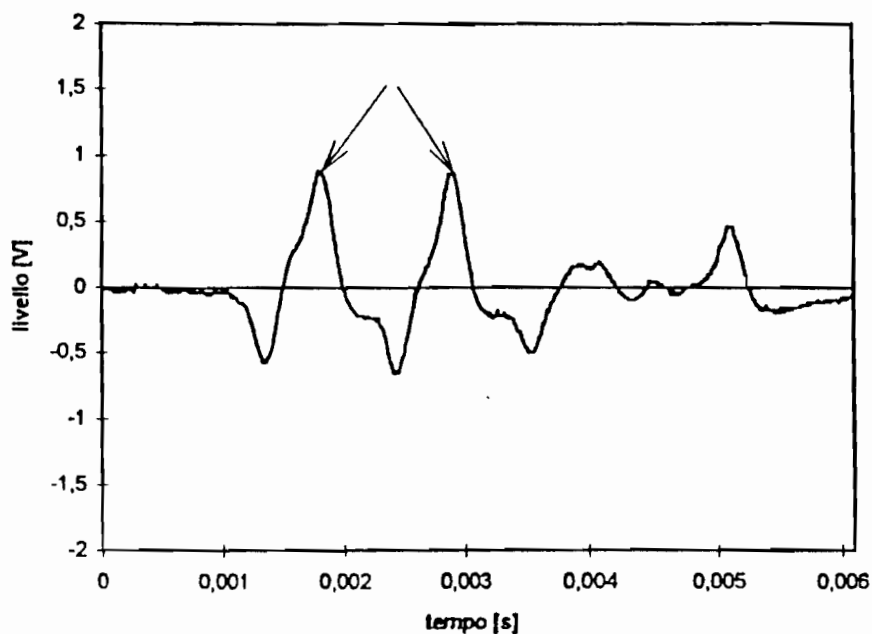
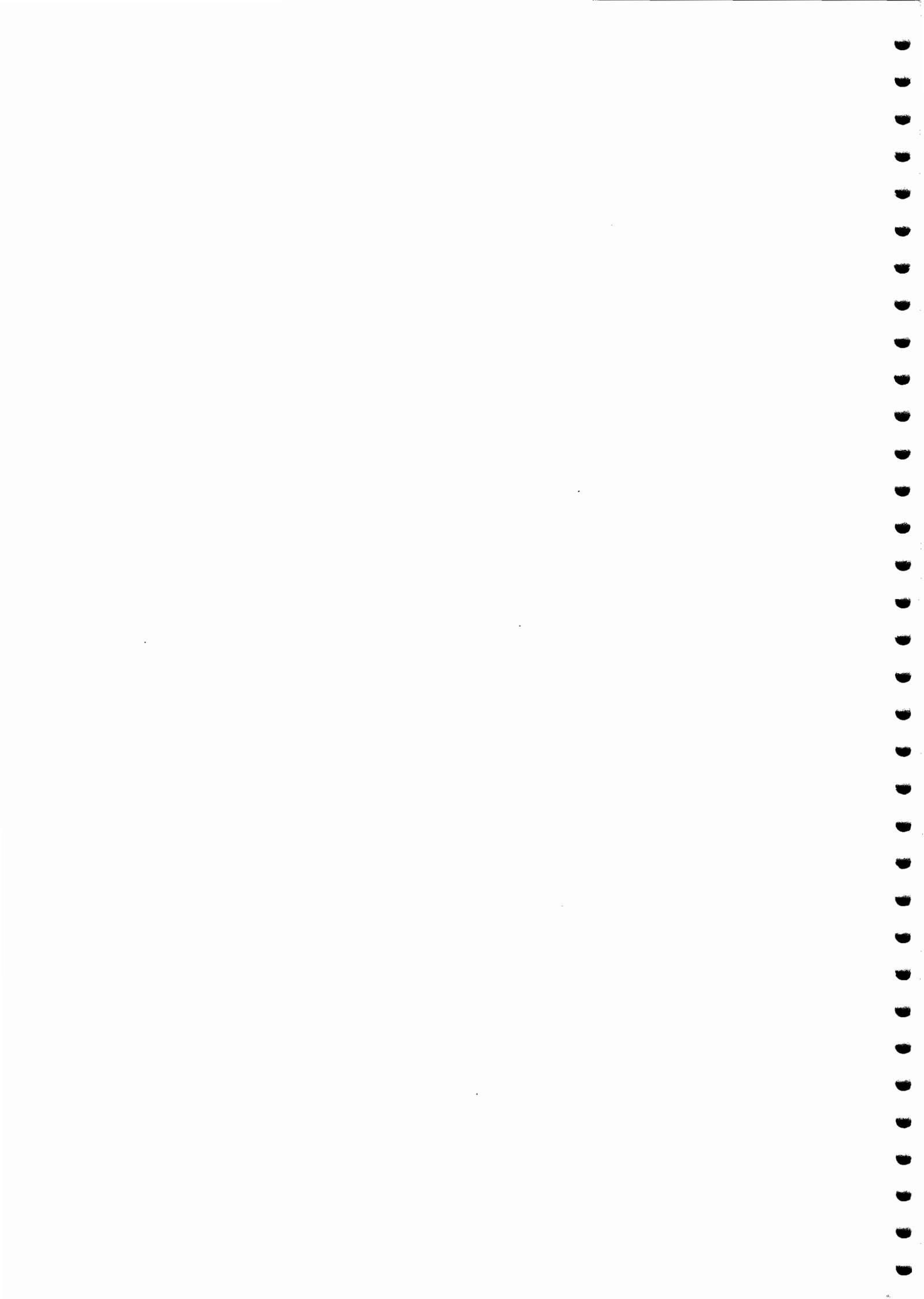


Fig. 4-7

Proceed as follows to make the adjustment:

- Switch the printer to the PR2 emulation for check reading operations
- Use the DAWRMN signal (end of magnetization) on J1 (3) as the oscilloscope trigger
- Display the TEAMP adjustment signal on the oscilloscope by drawing the voltage between J1(1) and J1(2).
- Activate the adjustment program that sets an E13B magnetization current knowing that the head forward path corresponds to the check's magnetization phase while the return path corresponds to the read phase
- Turning the potentiometer clockwise increases the amplitude of the signal, turning it counterclockwise decreases it.



## 5. DIAGNOSTICS GUIDE

### 5.1 SERVICING METHODS

The following pages contain a technical approach to servicing that can be used as a guide by less experienced technicians.

#### 5.1.1 INFORMATION CONCERNING THE FAULT

The operator who has detected the fault can give information concerning the operating side and the error indications from the printer when the fault occurred.

The repetition of the fault, when possible, can help to identify it.

For the diagnostics it is important to establish whether the fault is repetitive or random.

#### 5.1.2 OPERATING CONDITIONS ANALYSIS

##### ***WORKING ENVIRONMENT***

If the environment is too cold, too hot or damp, this could cause some faults.

The machine must not be placed near air conditioning system vents or exposed to direct sunlight.

Check the vents for internal ventilation, especially if the printer is fitted to a furniture.

Modules, documents or office equipment placed near the machine could cause a reduction in the internal ventilation and give rise to overheating.

##### ***ACCESSORIES AND MODULES***

Make sure that the accessories installed in the machine are originals and in good condition.

Check that the documents processed by the machine comply to the machine specifications and are in good condition.

##### ***PRINTER OPERATING CONDITION***

Check that the internal parts of the machine have no dirt deposited or residues of paper or ink that could interfere with the device performance.

Check that there is no internal damage caused by the introduction of documents with metal clips, staples, pins or similar.

Check that the parts specified are correctly lubricated.

### **5.1.3 PINPOINTING THE PROBLEM**

Carefully examine all the information obtained (information from the operator, printer error signals, analysis of the documents where the fault has occurred, repetition of the error when starting up the machine etc.) to recognize and pinpoint the fault on the machine that is to be solved.

At times the fault is generated by more than one cause: it is important in such cases to separate the faults and deal with them one at a time.

### **5.1.4 FINDING THE CAUSE**

Using experience as a guide, together with the information given in this section, take a logical path to find the fault, starting from the most probable cause through to the most remote probability, until the faulty part is found.

### **5.1.5 SOLVING THE PROBLEM**

Make the repairs so that the machine can return to carry out all its functions. At this stage the information given in chapters 6, 7, 8 and 9 can be of help.

### **5.1.6 MACHINE TESTING**

After the job has been completed, clean up the machine and run a complete test on it, if possible in the presence of the operator, to verify that the fault has been solved and that no others have arisen.

## 5.2 CLASSIFYING THE FAULTS

To make the search easier, the faults have been divided into:

- 5.3 power-on faults
- 5.4 document write faults
- 5.5 document handling faults
- 5.6 magnetic stripe read/write faults.

Each fault group provides a listing of the more probable failures and their possible causes.

The classification in this chapter cannot cover all the faults that could occur on the machine; if the fault found is not described herein, consult the description of a similar fault.

### 5.3 POWER ON FAULTS

<div style="text-align: center;"> <b>FAULT</b> </div> <div style="text-align: center;"> <b>POSSIBLE CAUSE</b> </div>	The printer does not power on	The autodiag. indicate a main board failure	The autodiag. indicate a mechanical failure	The printer is unable to connect with the system
Incorrect/missing line voltage	X			
Damaged power cord	X			
Power cord partly inserted	X			
Blown fuse	X			
Faulty power supply board	X			
Faulty transformer	X			
Faulty main board		X		X
Faulty front photosensors			X	
Faulty carriage photosensor			X	
Faulty rear photosensor			X	
Printer cover open			X	
Jammed paper			X	
Interface connection problems				X
Interface line problems				X
Incorrect setup				X

## 5.4 DOCUMENT WRITE FAULTS

<div style="text-align: center;">FAILURE</div> <div style="text-align: center;">POSSIBLE CAUSE</div>	The head does not write	Faded printing	Stained printing	Incomplete printing	Unaligned printing	Deformed printing with irregular spacings
Ribbon cartridge not installed	X	X				
Ribbon to be replaced (finished)		X				
Ribbon cartridge fitted incorrectly	X	X		X		
Incorrect setup parameters					X	X
Obstructions along carriage stroke	X					X
Closing levers open	X	X		X	X	
Faulty print head	X			X		
Faulty paper photosensor	X				X	X
Faulty head flat cable	X			X	X	X
Faulty transport motor	X					X
Faulty main board	X			X		
Paper feed belt adjustment					X	
Needle-platen distance adjustment	X	X	X	X		
Ribbon-needle protection fin adjust.	X	X	X	X		
Paper photosensor adjustment	X				X	X
Print bar adjustment	X	X				
Tab adjustment					X	
Roller gears adjustment					X	
Front pressure rollers adjustment					X	
Carriage movement belt adjustment					X	X



## 5.5 DOCUMENT HANDLING FAULTS

<div style="text-align: center;">FAILURE</div> <div style="text-align: center;">POSSIBLE CAUSE</div>	The printer does not load/expel the document	The document is moved crookedly	The document is crumpled	The document has irregular line feeds
Document not within specifications	X	X	X	X
Ruined document	X	X	X	X
Closing levers opened		X	X	X
Faulty front photosensors	X			
Faulty paper photosensor	X			
Faulty rear photosensor	X			
Faulty services motor	X			
Faulty paper feed motor	X			X
Faulty main board	X			
Document feed belt adjustment			X	
Needle-platen distance adjustment			X	
Ribbon-needle protection fin adjustment			X	
Paper photosensor adjustment	X		X	
Print bar adjustment			X	
Tab adjustment			X	
Roller gears adjustment				X
Front pressure rollers adjustment				

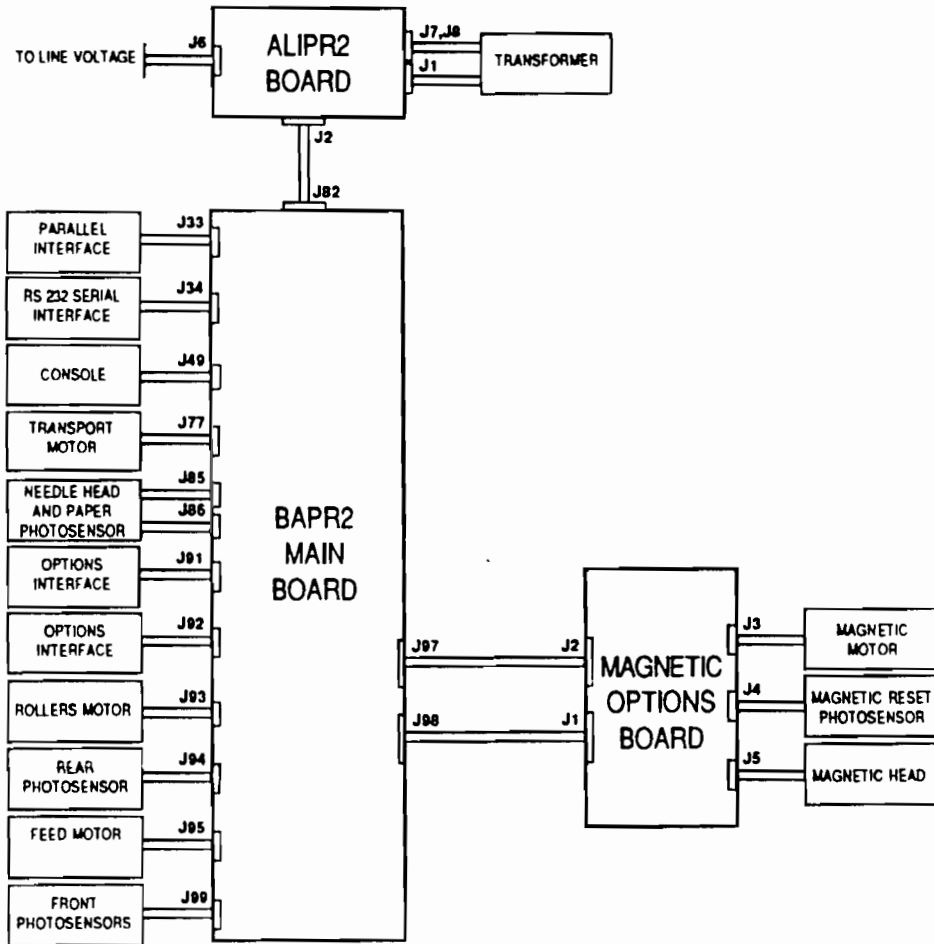
## 5.6 MAGNETIC STRIPE READ/WRITE FAILURES

<div style="text-align: center;">FAILURE</div> <div style="text-align: center;">POSSIBLE CAUSE</div>	The vertical magnetic band device performs read/write errors	The horizontal magnetic band device performs read/write errors
Incorrect setup	X	X
Ruined savings book	X	X
Incorrect savings book insertion	X	X
Dirty magnetic head	X	X
Faulty magnetic head	X	X
Faulty paper feed motor	X	X
Faulty magnetics band device board	X	X
Faulty main board	X	X
Faulty magnetic head movement motor	X	X



## 6. ELECTRICAL INTERCONNECTIONS

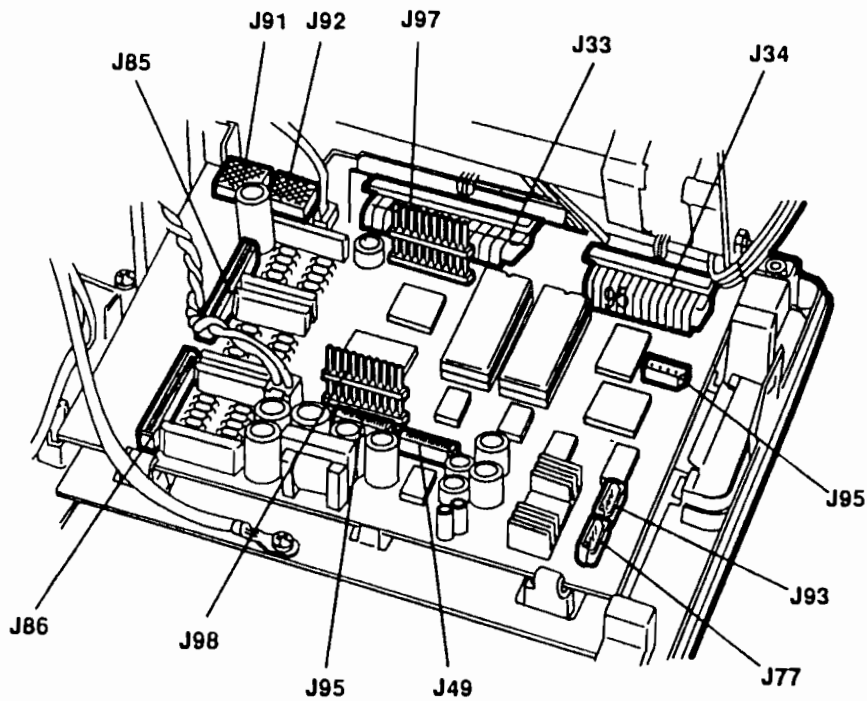
### 6.1 GENERAL PRINTER CABLING DIAGRAM



## 6.2 BAPR2 MAIN BOARD

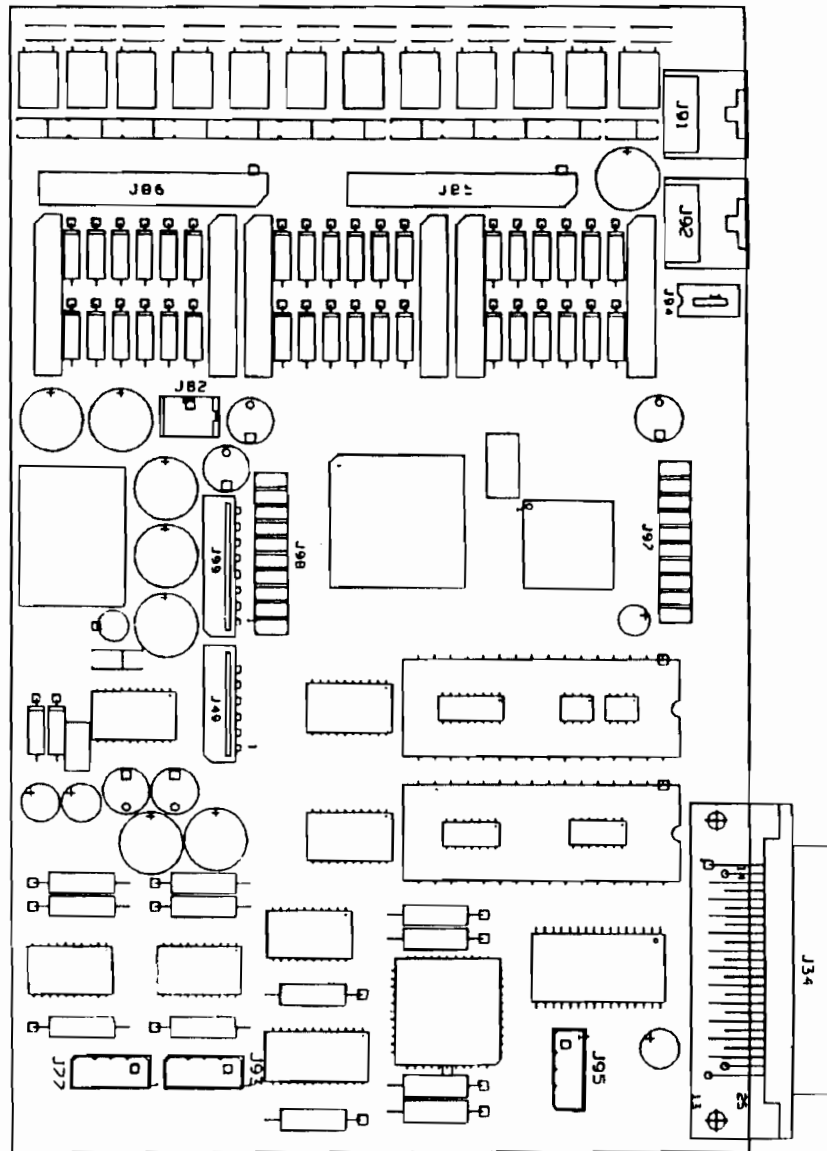
The BAPR2 board can be configured with a double interface (as shown in the figure) or without parallel interface connector and circuitry. The two board versions also have different codes.

### 6.2.1 BOARD VIEW AND LOCATION OF CONNECTORS



*Fig. 6-1 BAPR2 Main Board Installed in the Printer*

## 6.2.2 BOARD LAYOUT AND LOCATION OF CONNECTORS



*Fig. 6-2 BAPR2 Main Board*

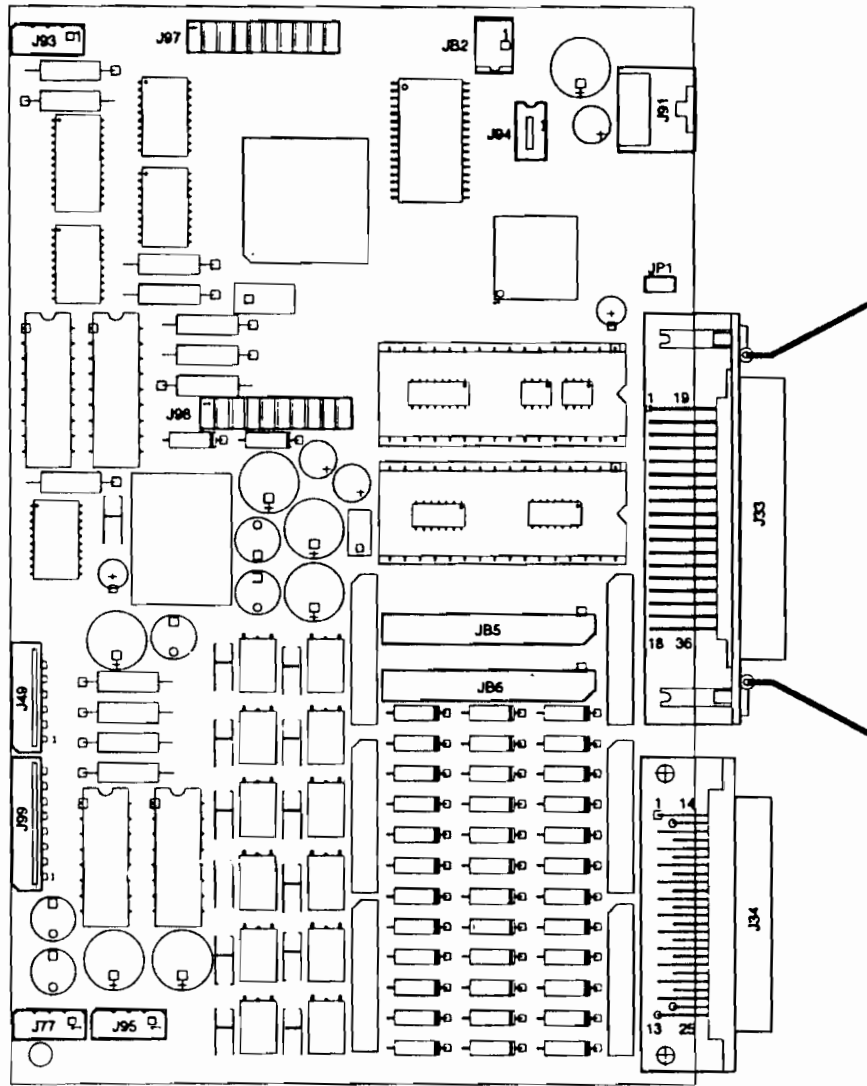


Fig. 6-3 BAPR2 - C.I. Main Board

## 6.2.3 CONNECTOR SIGNALS

These connectors are found on both the previous and cost improvement board versions with the exception of connector J33 which is not on the previous version.

**J33**  
(PARALLEL INTERFACE)

	19	GND
STROB	1 20	GND
DACX(0)	2 21	GND
DACX(1)	3 22	GND
DACX(2)	4 23	GND
DACX(3)	5 24	GND
DACX(4)	6 25	GND
DACX(5)	7 26	GND
DACX(6)	8 27	GND
DACX(7)	9 28	GND
ACK00	10 29	GND
BUSY1	11 30	GND
PAPEMP	12 31	IMPRA
SELOUT	13 32	FAULTCX
AUTOLF	14 33	GND
-	15 34	-
GND	16 35	TIR00
GND	17 36	SELINP
VCC	18 37	GND
	38	GND

**J34**  
(RS232 INTERFACE)

GND	1	14
TXD1	2	15
RXD1	3	16
RTS1	4	17
CTS1	5	18
DSR1	6	19
GND	7	20
DCD1	8	21
	9	22
	10	23
	11	24
	12	25
	13	

DTR  
GND

**J49**  
(CONSOLE)

1	GND
2	P5CONS
3	LED3
4	LEDLOC
5	LED2
6	LED1
7	LEDON
8	TAS01
9	TALOC
10	TAS02
11	COPEN
12	GND

**J77**  
(TRANSPORT MOTOR)

1	FASEA
2	FASEB
3	FASEC
4	FASED

**J82**  
(POWER SUPPLY)

1	PIU35
2	GND

**J85**  
(PRINT NEEDLE CONNECTION)

1	TESTE
2	LEBCA
3	FOBCA
4	VCC
5	R0224
6	SPL(2)
7	R0422
8	SPL(4)
9	R0620
10	SPL(6)
11	R1214
12	SPL(12)
13	R0717
14	SPL(17)
15	R1113
16	SPL(13)
17	R1113
18	SPL(11)
19	R0519
20	SPL(5)
21	R0422
22	SPL(22)
23	R0123
24	SPL(23)
25	R0519
26	SPL(19)

**J86**  
(PRINT NEEDLE CONNECTION)

1	R0818
2	SPL(8)
3	R1016
4	SPL(10)
5	R1214
6	SPL(14)
7	R0818
8	SPL(18)
9	R1016
10	SPL(16)
11	R0915
12	SPL(15)
13	R0915
14	SPL(9)
15	R0717
16	SPL(7)
17	R0321
18	SPL(3)
19	R0123
20	SPL(1)
21	R0620
22	SPL(20)
23	R0224
24	SPL(24)
25	R0321
26	SPL(21)



**J94**  
(REAR PHOTOSENSOR)

1	LECOM
2	VCCPO
3	FOCOM

**J95**  
(FEEDER MOTOR)

1	TRF1A
2	TRF1B
3	TRF2A
4	TRF2B

**J93**  
(ROLLER MOTOR)

1	MR01A
2	MR01B
3	MR02A
4	MR02B

**J97**  
(MAGNETIC BAND OPTION)

1	VCC
2	GKMOT
3	DACOM
4	FAZMA
5	PMAGN
6	VERMA
7	RESE0
8	F2FDA
9	PIU12
10	GND

**J98**  
(MAGNETIC BAND OPTION)

1	MAC21
2	MAC20
3	MAC11
4	MAC10
5	MAPH2
6	MAPH1
7	PIU35
8	PIU35
9	GND
10	GND

**J99**  
(FRONT PHOTOSENSORS)

1	FOCOM
2	VCCAL2
3	LECOM
4	LEAL3
5	LECOM
6	FOCOM
7	VCCAL4
8	FOAL3
9	VCC
10	FOAN2
11	LEAN2
12	LEAN1
13	FOAL1
14	FOAN2
15	LEAL1

### 6.3 ALIPR2 BOARD

Two codes can be assigned to the ALIPR2 board depending on the line voltage (115 V or 230 V) at which they are set. Also the value of fuse F1 depends on the line voltage.

#### 6.3.1 BOARD VIEW AND LOCATION OF COMPONENTS

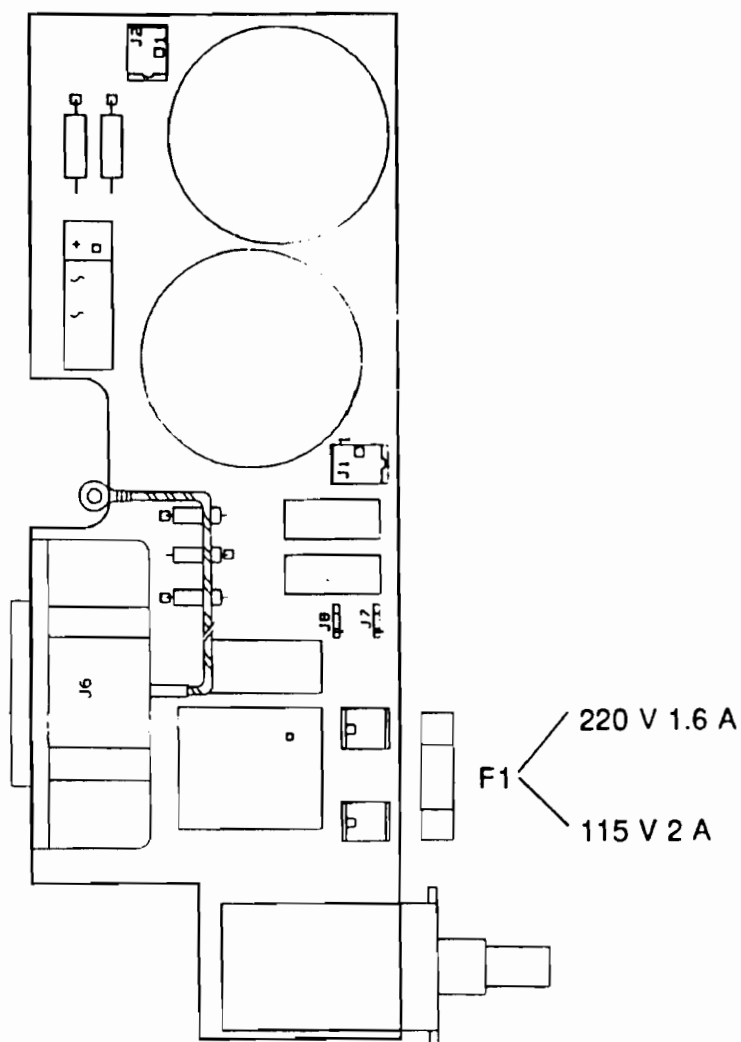


Fig. 6-4 ALIPR2 Board

## 6.3.2 CONNECTOR SIGNALS AND FUSE VALUES

**J1**  
(TRANSFORMER SECONDARY)

1	BTF
2	BTN

**J2**  
(MAIN BOARD POWER SUPPLY)

1	PIU35
2	GND

**J6**  
(LINE VOLTAGE INPUT)

1	ATF
2	GND
3	ATN
4	GND
5	GND

**J7**  
(TRANSFORMER PRIMARY)

1	TRASF1
---	--------

**J8**  
(TRANSFORMER PRIMARY)

1	TRASF2
---	--------

**F1**  
(FUSE)  
115 V    XXX mA  
230 V    XXX mA

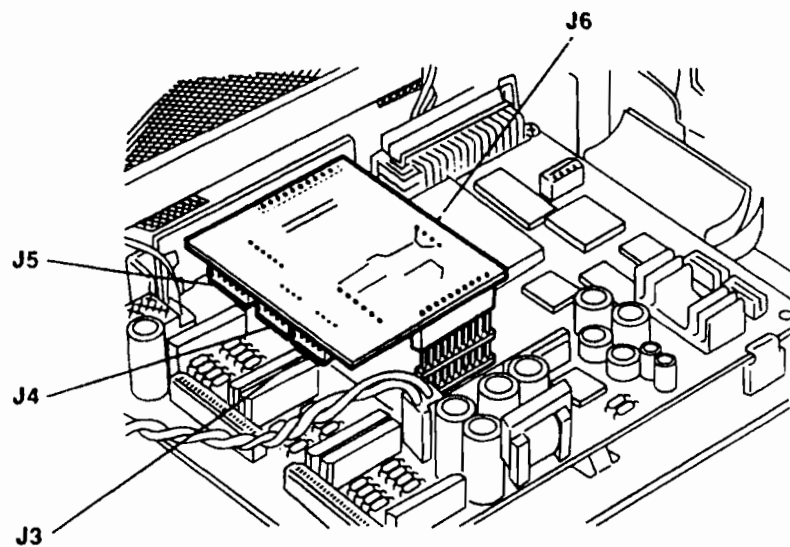
## 6.4 BOARDS FOR MAGNETIC AND MICR OPTIONS

The following cards can be installed on the BAPR2 main board depending on the type of magnetic option installed:

- Card PR2MAGN, for horizontal magnetic band option management
- Card PR2MIMAG, for horizontal magnetic band option and MICR check reader management.
- Card PR2VER, for vertical magnetic band option management

The installed option is controlled by a dedicated FW according to the machine setup parameters.

### 6.4.1 BOARD VIEW AND LOCATION OF CONNECTORS



*Fig. 6-5 Options Card Installed in the Printer*

### 6.4.2 PR2MAGN BOARD LAYOUT AND LOCATION OF CONNECTORS

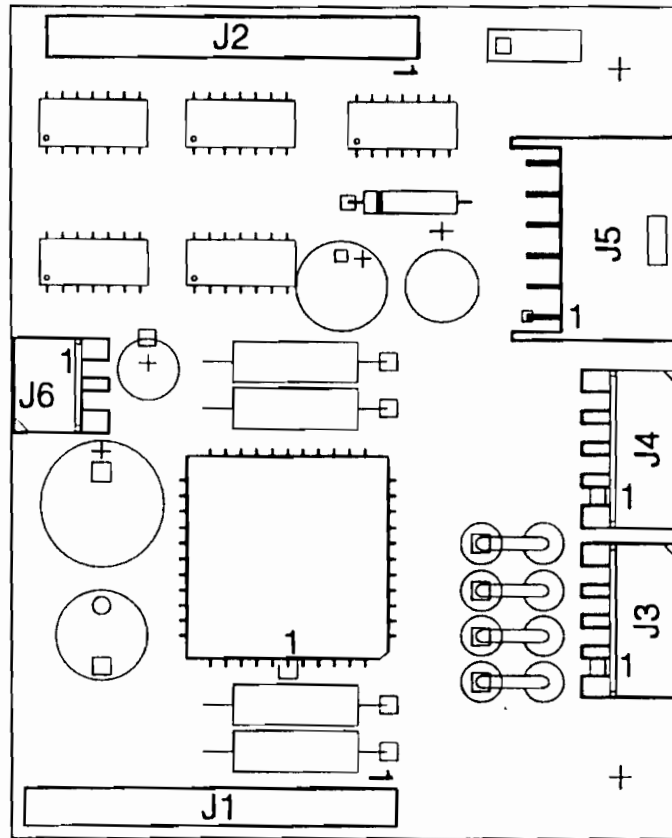


Fig. 6-6 PR2MAGN Board

## 6.4.2.1 CONNECTOR SIGNALS

### J1

(MAIN BOARD CONNECTION)

1	MAC21
2	MAC20
3	MAC11
4	MAC10
5	MAPH2
6	MAPH1
7	PIU35
8	PIU35
9	GND
10	GND

### J2

(MAIN BOARD CONNECTION)

1	VCC
2	DAWRM
3	DACOM
4	FAZMA
5	GND
6	VERMA
7	RESE0
8	F2FDA
9	PIU12
10	GND

### J3

(MAGNETIC MOTOR)

1	FAM0
2	FAM1
3	FAM2
4	FAM3

### J4

(MAGNETIC RESET PHOTO.)

1	VCC
2	VCC
3	LED1
4	FAZZ0

### J5

(MAGNETIC HEAD)

1	WRI1
2	WRI0
3	GND
4	GND
5	LEO1
6	LEO0

### J6

(ADJUSTMENTS)

1	OUT1
2	GND

### 6.4.3 PR2MIMAG BOARD LAYOUT AND LOCATION OF CONNECTORS

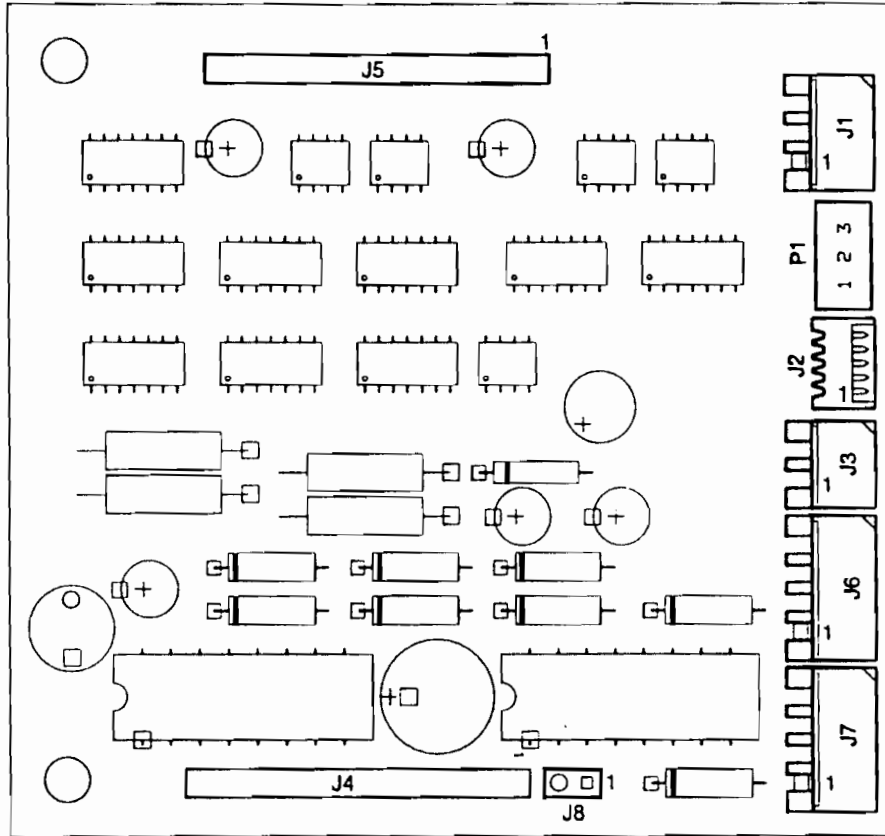


Fig. 6-7 PR2MIMAG Board

### 6.4.3.1 BOARD PR2MIMAG CONNECTOR SIGNALS

#### J1

(MCR ADJUSTMENT CONNECTOR)

1	TEAMP
2	GND
3	DAWRMN

#### J2

(MCR MAGNETIC HEAD)

1	LEDO0
2	WRI0
3	GND
4	WRI1
5	LED1

#### J3

(HORIZONTAL MAGNETIC BAND CONNECTOR TEST)

1	OUT1
2	GND

#### J6

(MAGNETIC UNIT RESET PHOTO.)

1	VCC
2	VCC
3	LED0
4	FAZma

#### J7

(TRANSPORT MOTOR)

1	TRF1A
2	TRF1B
3	TRF2A
4	TRF2B



#### 6.4.4 PR2VER BOARD LAYOUT AND LOCATION OF CONNECTORS

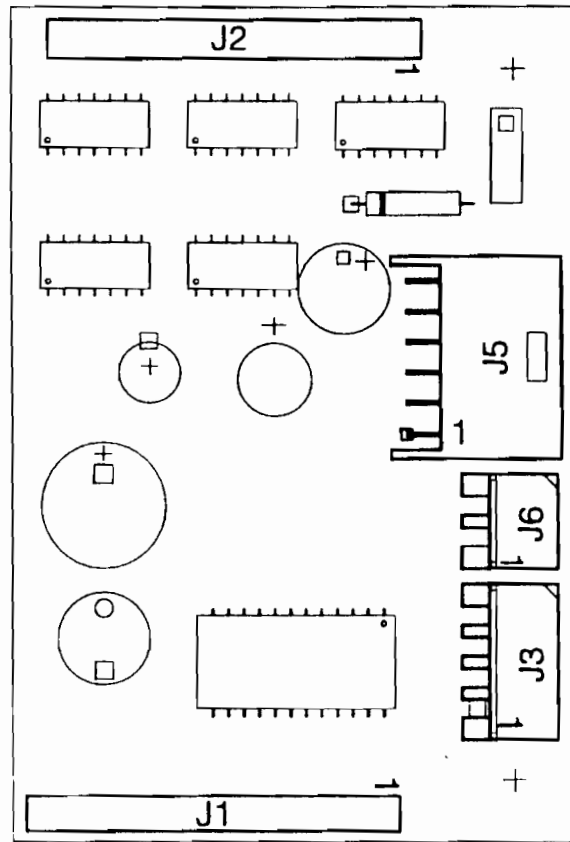


Fig. 6-8 PR2VER Board

### 6.4.4.1 PR2VER BOARD CONNECTOR SIGNALS

#### J1

(CONNECTION TO MAIN BOARD)

1	MAC21
2	MAC20
3	MAC11
4	MAC10
5	MAPH2
6	MAPH1
7	PIU35
8	PIU35
9	GND
10	GND

#### J2

(CONNECTION TO MAIN BOARD)

1	VCC
2	DAWRM
3	DACOM
4	FAZMA
5	PMAGN
6	VERMA
7	RESE0
8	F2FDA
9	PIU12
10	GND

#### J3

(MAGNETIC UNIT MOTOR)

1	FTR1B
2	FTR1A
3	FTR2B
4	FTR2A

#### J4

(MAGNETIC UNIT RESET PHOTO.)

1	VCC
2	VCC
3	LED1
4	FAZZ0

#### J5

(MAGNETIC HEAD)

1	WR11
2	WR10
3	GND
4	GND
5	LEO1
6	LEO0

#### J6

(ADJUSTMENTS)

1	OUT1
2	GND

# 6.5 CONSOLE

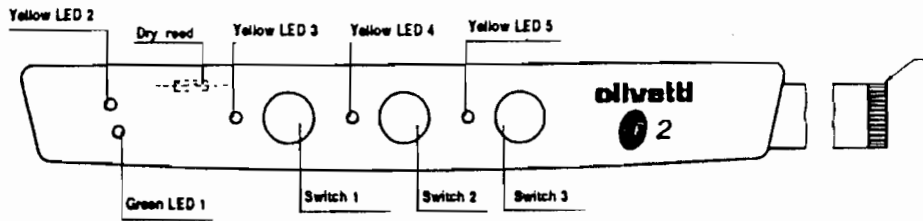


Fig. 6-9 Console

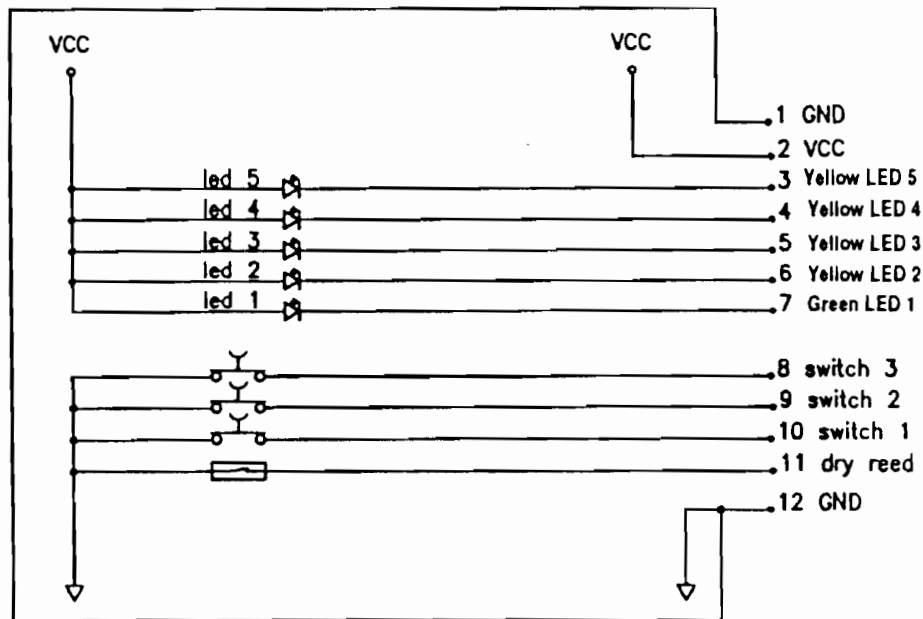


Fig. 6-10 Console Electrical Diagram

## **7. PREVENTIVE MAINTENANCE**

### **7.1 CLEANING**

In order that the printer functions well it is advised to clean the internal parts periodically and in any case whenever it is serviced.

#### **7.1.1 CLEANING THE PRINTER CASE**

Firstly power off the printer and then disconnect it from the electrical power socket. Clean the case using a damp cloth; avoid the use of corrosive substances such as solvents, alcohol solutions, petrol or abrasive components.

#### **7.1.2 CLEANING THE PAPER PATHS**

Clean all the document paths including the paper transport rollers of the front infeed device and the cheques module feeder, taking care to remove any paper or ribbon residues that have deposited on the parts, or any foreign bodies.

#### **7.1.3 CLEANING THE READING HEAD FOR HORIZONTAL/VERTICAL/MICR MAGNETIC STRIPS**

To clean, use the special card (code 751498E) supplied with machines that have vertical or horizontal magnetic devices or the MICR unit installed.

Cleaning can be carried out either automatically or manually by the field engineer.

**AUTOMIZED PROCEDURE**

Through a specific software procedure the system informs the user that cleaning is necessary and engages a dummy magnetic transaction.

The cleaning instructions, if not supplied by the system, are indicated on the cleaning card.

The automatized cleaning procedure is usually carried out by the operator.

**MANUAL PROCEDURE**

This type of cleaning is carried out by the service technician regardless of programmed cleaning foreseen by the automatized procedure.

It is necessary to run a command from the magnetic stripe reading system.

Insert the cleaning card in the infeed device taking care to position it correctly.

The machine will make an attempt to read the card, after which it will expel the card and indicate an error.

To bring the machine back to normal operating conditions, power off, exit from testing procedure then power on again.

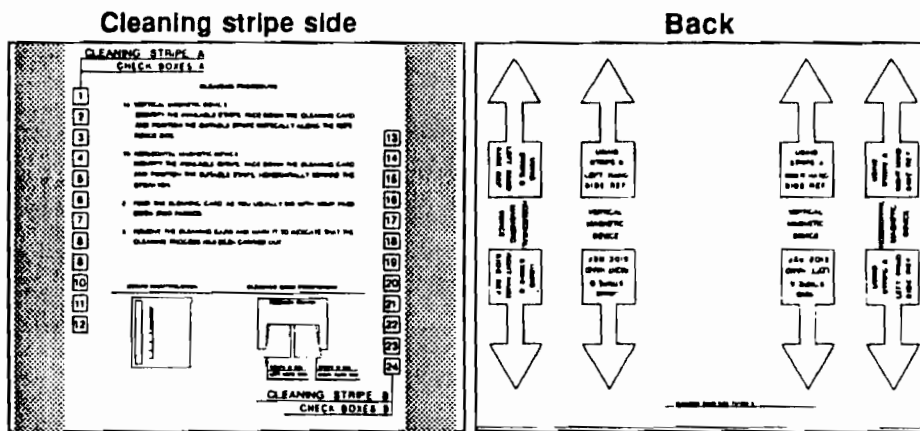


Fig. 7-1 Magnetic heads cleaning card

## 7.2 LUBRICATION

Although lubrication is not foreseen during the machine life, the technician should, during each service call, check the lubrication using the table below for reference on the parts to be lubricated.

### 7.2.1 BASIC MACHINE LUBRICATION POINTS

DESCRIPTION	CODE	GREASE	OIL
Print head carriage slide shafts			X
Carriage shield guide shaft			X
Carriage felt	473150E		X
Ribbon feed gear assembly		X	
Cam in the area in contact with:	473072X	X	
Reed support pin,	473076T	X	
Pressure device bridge roller	473074Z	X	
Bushing hole	473170A	X	
	473171X	X	
Central pressure device in the shaft contact area	473167T	X	
Bushings in the shaft contact area	473087P	X	
	473088Y	X	
Motor gear,	473070H	X	
gear	473071W	X	
and cam teeth	473072X	X	
Assembly gear	473174S	X	
and pulley toothing	473017Q	X	
Hooking area leaf spring	473182K	X	
Ribbon feed pin rotation axis	473147X	X	
Belt tightener pin with return pulley	473149H	X	
Alignment rollers shaft	473079E	X	
Rubber in the damper assembly hole	473059A	X	
Print crosspiece	473040B	X	
Left pin and ballast	473049G	X	
Guide hole center pin		X	
Left bracket holes and pins			
Crosspiece adjustment			

Grease: Code 3233350 X MAGNALUBE - E

Oil: Code 757283 C - FOMBLINY 06 oil (perfluorate polyether)  
Supplier: Ausimont, Montedison Group

**7.2.2 HORIZONTAL MAGNETIC DEVICE LUBRICATION POINTS**

DESCRIPTION	CODE	GREASE	OIL
Carriage slide shafts			X
Return pulley, between pin and roller cage		X	
Door, on rotation pins		X	
Sector gear on its own pin		X	
Door pinion set gear		X	
Carriage inclined plane in the door closing lever control area		X	
Pressure device command inside cam		X	

Grease: Code 3233350 X MAGNALUBE - E

Oil: Code 757283 C - FOMBLINY 06 oil (perfluorate polyether)  
 Supplier: Ausimont, Montedison Group

### 7.2.3 VERTICAL MAGNETIC DEVICE LUBRICATION POINTS

DESCRIPTION	CODE	GREASE	OIL
Guide shaft			X
Carriage pin		X	
Motor cam		X	
Mylar shaft on pressure supports		X	

Grease: Code 3233350 X MAGNALUBE - E

Oil: Code 757283 C - FOMBLINY 06 oil (perfluorate polyether)  
Supplier: Ausimont, Montedison Group





## 8. MECHANICAL ADJUSTMENTS

The mechanical adjustments, for easier consultation, have been divided into:

- **8.1.X** Adjustments on the basic machine, with no options
- **8.2.X** Adjustments on the basic machine options (Vertical Magnetic Device, Horizontal Magnetic Device)

Each individual adjustment is divided into:

- **Machine arrangement.** Describes the arrangement of the printer in order to carry out the adjustment.
- **Conditions to be checked.** Indicates the points, values and tolerances to be observed to ensure good linkage operation.
- **Operating procedure.** Lists the operations to be carried out to make the adjustment.
- **Notes.** Any references to adjustment sequences or tests to be carried out to check the adjustment.

## 8.1 BASIC MACHINE ADJUSTMENTS

### 8.1.1 ADJUSTING THE DOCUMENT FEED BELT

**MACHINE CONDITION:**

Unimportant.

**OBJECTIVE ADJUSTMENT:**

The tension of timing belt (1) must sag 2.3 mm when applying 200 g at the center of the lower span.

**PROCEDURE:**

Loosen the motor securing nuts (2), tighten the belt accordingly and then retighten the nuts.

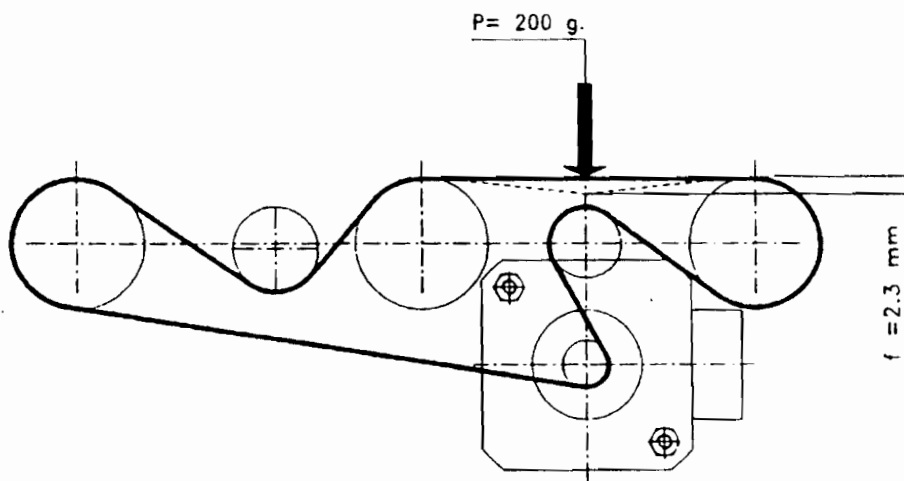


Fig. 8-1

## 8.1.2 ADJUSTING THE DISTANCE BETWEEN PLATEN AND NEEDLES

### **MACHINE CONDITION:**

Unimportant.

### **OBJECTIVE ADJUSTMENT:**

A distance of 0.37/0.42 mm between the tip of the needles and the probe roller.

### **PROCEDURE:**

Position the print head so that surface (A) is perfectly orthogonal with respect to the axis of comparator (B).

Adjust screws (1) that secure probe roller (2) onto head (3) and regulate the distance between the roller and needles. Tighten the screws again.

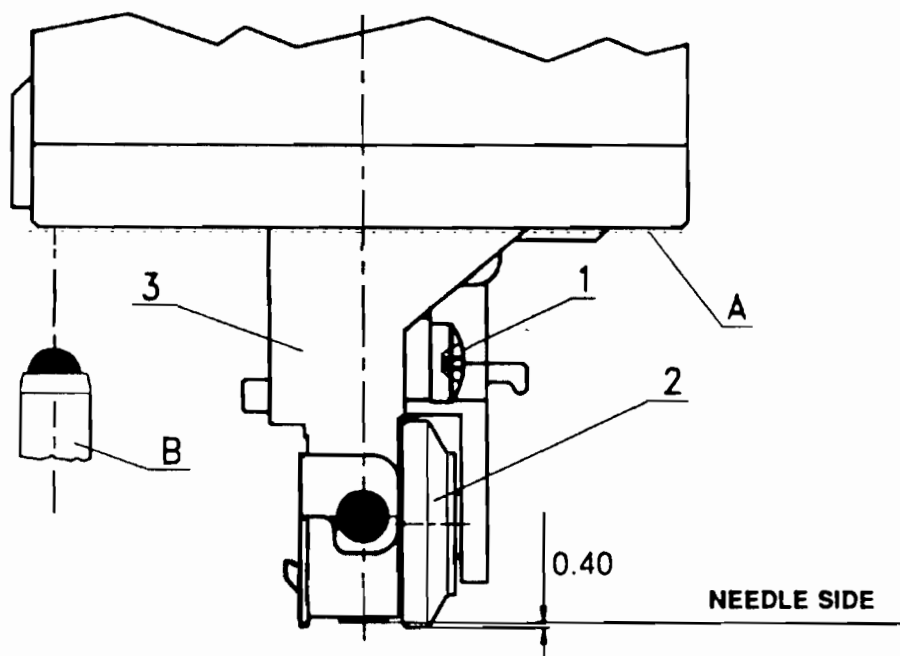


Fig. 8-2

**Note:** After this procedure check whether it is necessary to readjust the distance of the ribbon/needles protection fin (8.1.3).

### 8.1.3 ADJUSTING THE DISTANCE OF THE RIBBON/NEEDLE PROTECTION FIN

**MACHINE CONDITION:**

Unimportant.

**OBJECTIVE ADJUSTMENT:**

A distance of 0.28/0.32 mm between the tips of the needles and the ribbon protection fin.

**PROCEDURE:**

Position the head so that surface (A) is perfectly orthogonal to the axis of comparator (B).

Loosen screw (1) that secures ribbon protection fin (2) onto the head (3) and, using the comparator, adjust the distance of the fin/needle edge. Tighten the screws again.

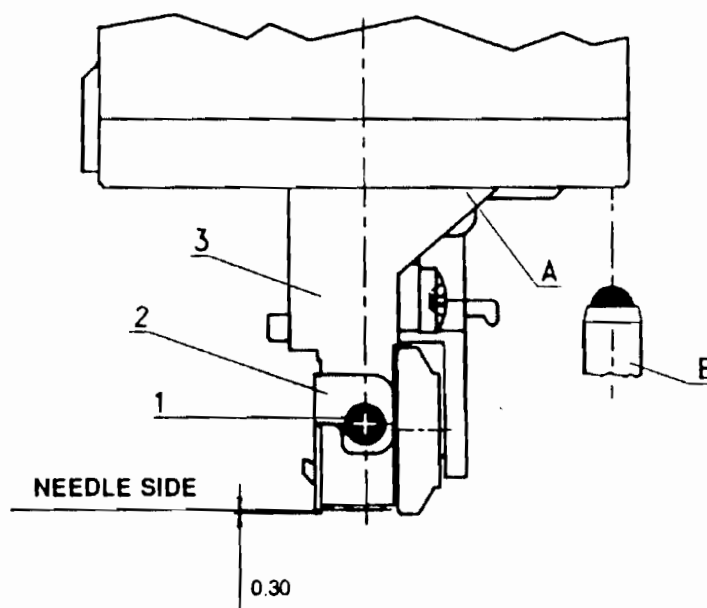


Fig. 8-3

**Note:** After this procedure check whether it is necessary to readjust the distance between the platen and needles (8.1.2).

#### 8.1.4 ADJUSTING THE PAPER PHOTOSENSOR

**MACHINE CONDITION:**

Unimportant.

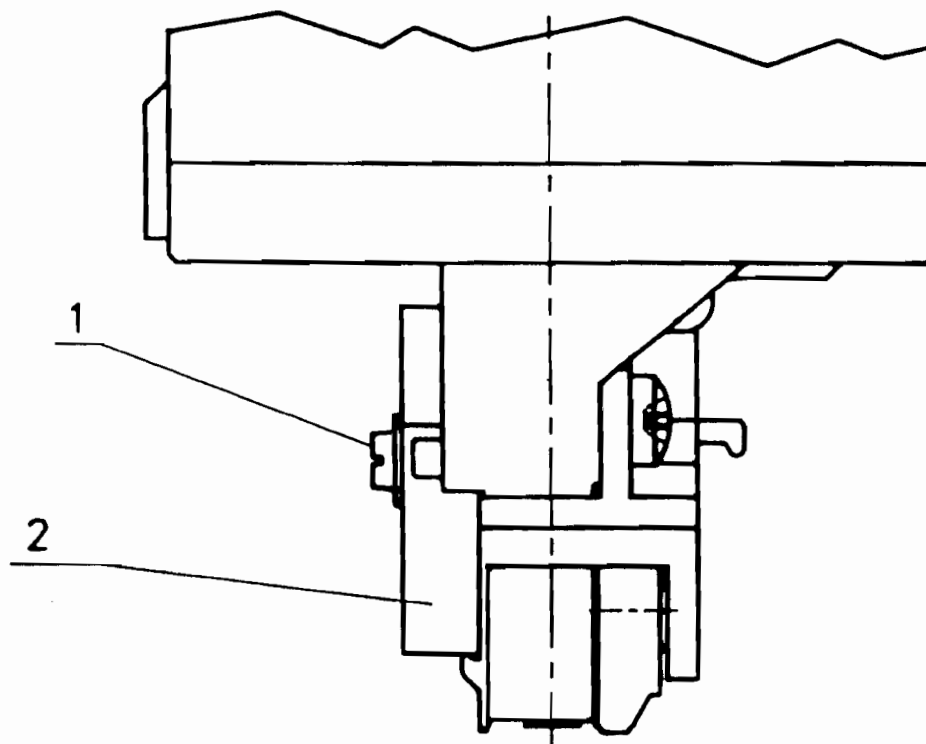
**OBJECTIVE ADJUSTMENT:**

The correct positioning of the paper photosensor on the print head.

**PROCEDURE:**

By means of screw (1) secure photosensor (2) onto the print head, tight against the reference profile obtained on the ribbon protection fin.

Make sure that the component rests on the entire width of the reference profile.



*Fig. 8-4*

**Note:** Carry out this procedure after adjusting the distance between the ribbon protection fin and needles (8.1.3).

### 8.1.5 ADJUSTING THE PRINT BAR

**MACHINE CONDITION:**

The print head must be in a coaxial position with respect to the axis of the screw used for this adjustment.

**OBJECTIVE ADJUSTMENT:**

A distance of 0.5 mm must be measured between the frame's lower shield (1) and the head of screw (2).

**PROCEDURE:**

While holding the print head carriage on the axis, adjust screw (2) until obtaining the required distance. Repeat this procedure on the other screw located on the opposite side of the frame.

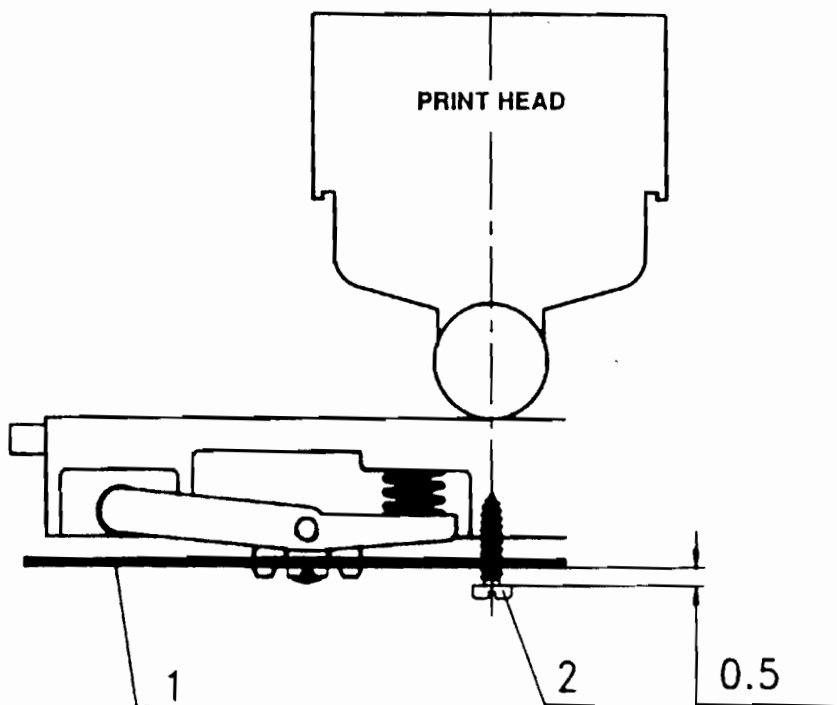


Fig. 8-5

## 8.1.6 TAB ADJUSTMENTS

### **MACHINE CONDITION:**

The upper mechanical assembly must be raised.

### **OBJECTIVE ADJUSTMENT:**

Tab (1) must come into contact with print bar (2), and simultaneously the balancer must come into contact with tab support shaft (4).

### **PROCEDURE:**

Loosen screw (5) and position the parts as explained. Tighten the screw.

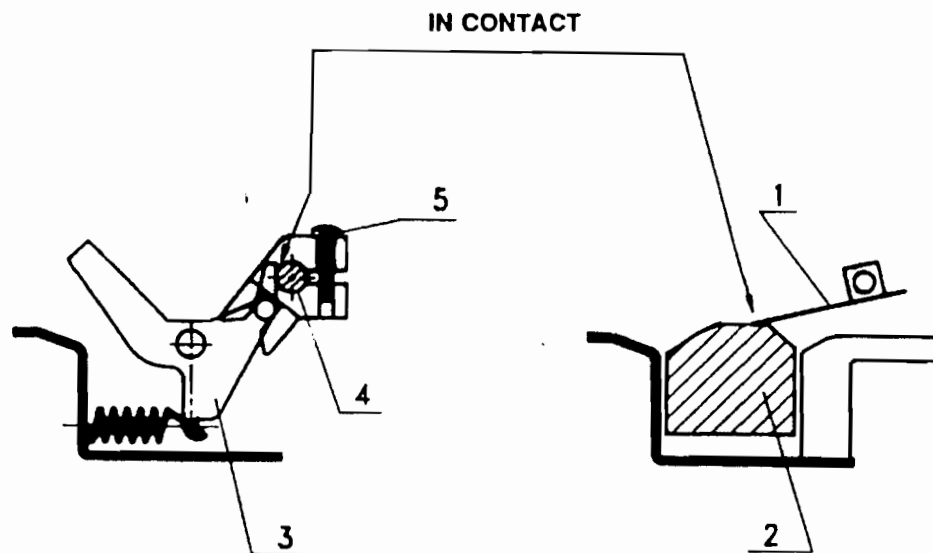


Fig. 8-6

**Note:** Carry out this procedure after adjusting the print bar (8.1.5).



### 8.1.7 ADJUSTING THE ROLLER GEARS

**MACHINE CONDITION:**

The upper mechanical assembly must be closed.

**OBJECTIVE ADJUSTMENT:**

Mesh between toothed wheels (1) and (2) with a maximum radial clearance of 0.2 mm between the teeth.

Check for this clearance throughout the entire wheel rotation.

Adjust the two matings on the right-hand side of the printer.

**PROCEDURE:**

Turn screws (3) securing the bushing, tightening them with a torque equivalent to  $6 \pm 0.5$  Kgcm.

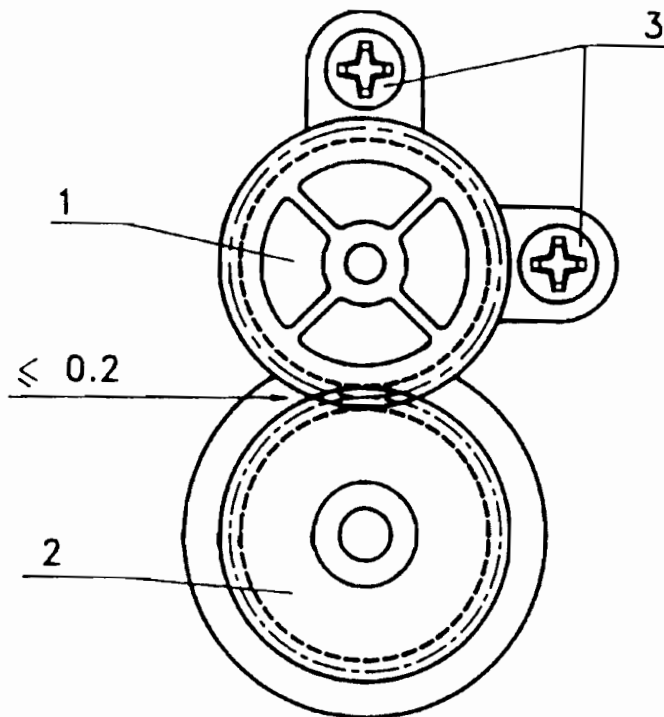


Fig. 8-7

**Note:** Carry out this adjustment on both gear pairs on the printer.

## 8.1.8 ADJUSTING THE FRONT PRESSURE ROLLERS

### **MACHINE CONDITION:**

Services cam with its minimum throw area facing the probe roller.

### **OBJECTIVE ADJUSTMENT:**

Make sure there is a small clearance between the probe roller (7) and the services cam (6).

### **PROCEDURE:**

Insert a 0.5 mm thick probe (1) between the pressure rollers (5) and the feed rollers by acting on shaft (2), then position the three levers (3) that are in contact with the springs and tighten the screws (4) with a torque of 20 Kgcm while holding the roller against the cam's smallest radius.

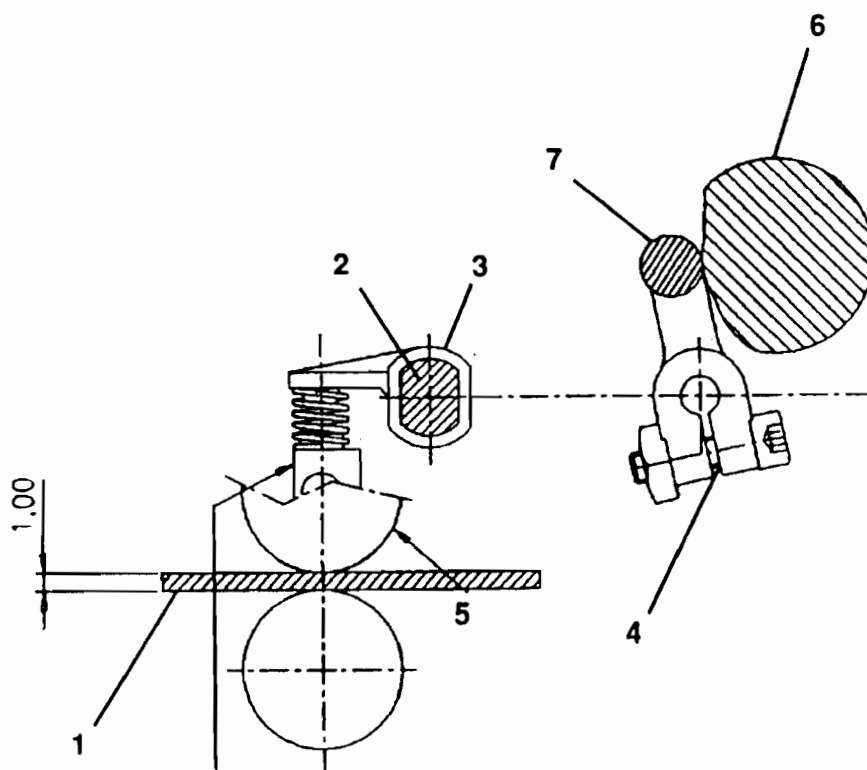


Fig. 8-8

### 8.1.9 ADJUSTING TAB OPENING

**MACHINE CONDITION:**

Upper mechanical assembly lifted and lever (1) in contact with lifting lever (2) control pin.

**OBJECTIVE ADJUSTMENT:**

A distance of 7 mm between the edge of the tab and the print bar.

**PROCEDURE:**

Turn screw (3) securing lever (1) onto the tab shaft.

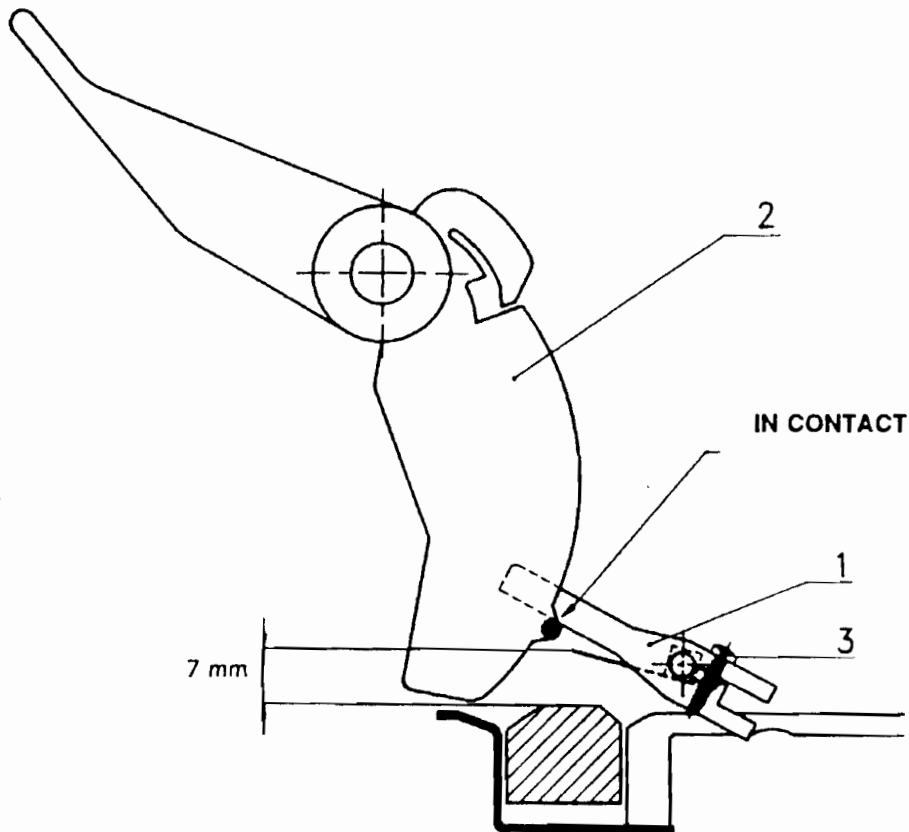


Fig. 8-9

**Note:** This adjustment must be performed after the print bar adjustment (8.1.5) and the tab adjustment (8.1.6).

### 8.1.10 ADJUSTING THE TENSION OF THE CARRIAGE MOVEMENT BELT

**MACHINE CONDITION:**

Unimportant.

**OBJECTIVE ADJUSTMENT:**

Return pulley support slide pushed by the traction spring towards the outside of the printer.

**PROCEDURE:**

Loosen screw (1), make sure the slide runs freely and then tighten the screw again.

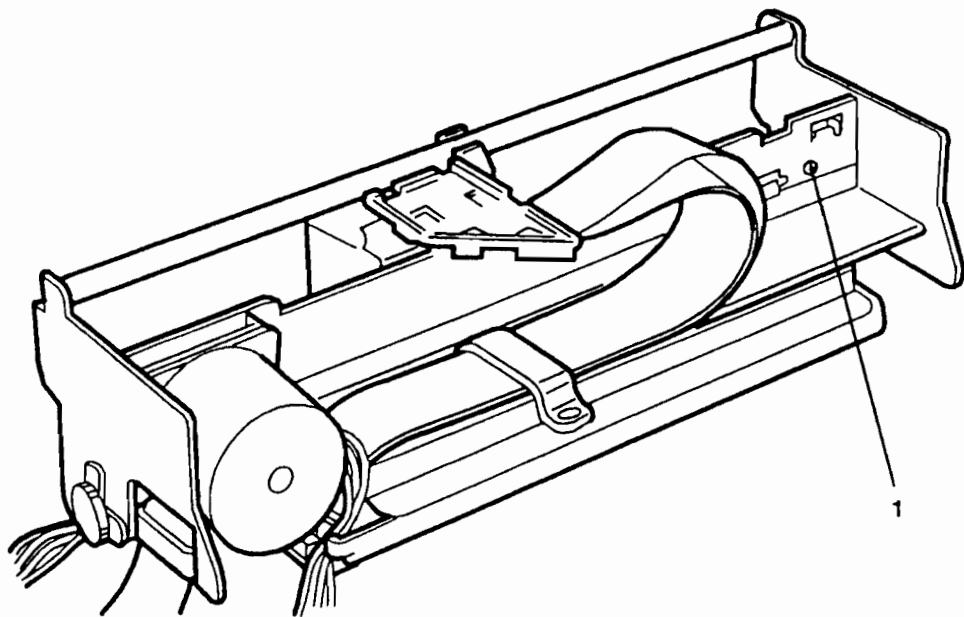


Fig. 8-10

## 8.2 ADJUSTMENTS FOR BASIC MACHINE OPTIONS

### 8.2.1 HORIZONTAL MAGNETIC DEVICE/MICR OPTION - ADJUSTING THE TENSION OF THE CARRIAGE FEED BELT

**MACHINE CONDITION:**

Read/write carriage in its reset position (end of stroke at the motor side).

**OBJECTIVE ADJUSTMENT:**

Tension of timing belt (1) so as to obtain a 5 mm sag when 60 g are applied at the center of the carriage stroke.

**PROCEDURE:**

Loosen the securing screws and move motor (2) until the objective adjustment is reached, then tighten the screws.

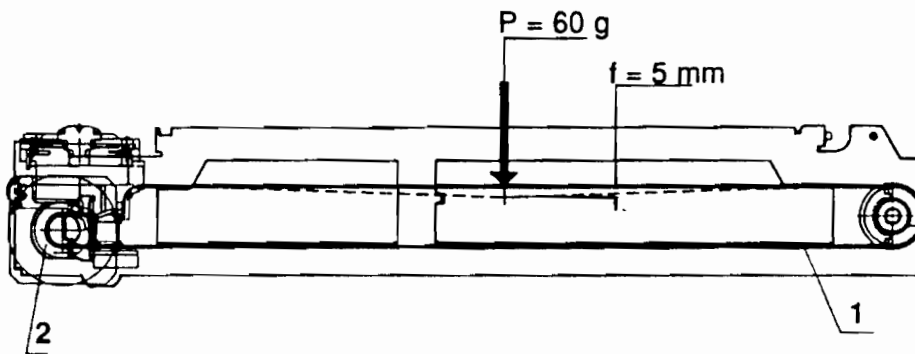


Fig. 8-11

## 8.2.2 HORIZONTAL MAGNETIC DEVICE/

## PTION - ADJUSTING THE DOOR

### **MACHINE CONDITION:**

The read/write carriage must be at its reset position (full stroke at the motor side) and semi-tie rod joining screw (1) loose.

### **OBJECTIVE ADJUSTMENT:**

Planarity between the door and the frame front surface.

### **PROCEDURE:**

Fit the door on the frame while keeping it in a vertical position so that the first tooth of the sector gear (2) fits into the tooth-less area of the door gear (3).

Turn the door to a horizontal position and, while keeping it coplanar with the frame's front surface, tighten the semi-tie rod joining screw (1).

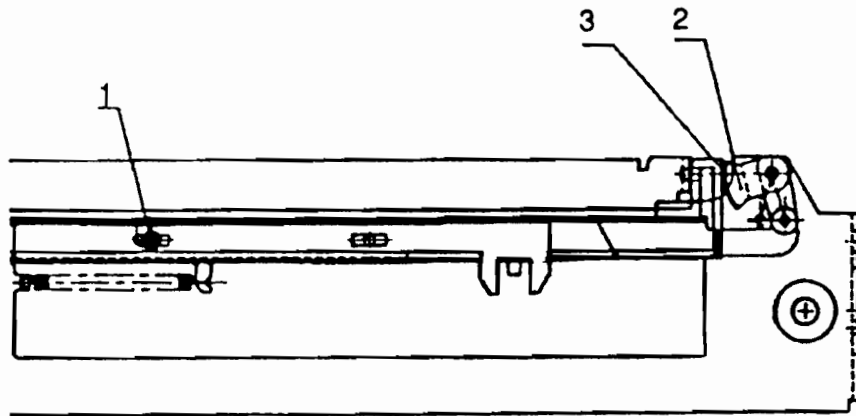


Fig. 8-12

### 8.2.3 HORIZONTAL MAGNETIC DEVICE/MICR OPTION - PRESS POSITIONING

**MACHINE CONDITION:**

Cam crank in contact on the shortest cam radius.

**OBJECTIVE ADJUSTMENT:**

Press in its working position (in contact with the frame).

**PROCEDURE:**

Loosen the cam handle securing screw (1), place the components and tighten the screw with a torque of 20 Kgcm.

Make sure that the press does not project from the paper conveyor profile when the cam is in its maximum control position.

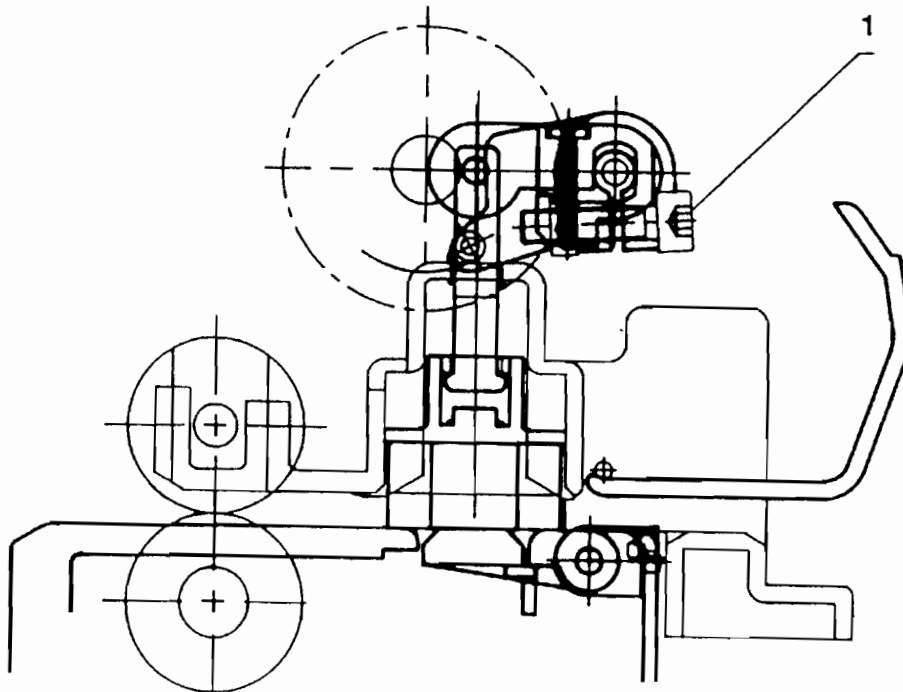


Fig. 8-13

## 8.2.4 HORIZONTAL MAGNETIC DEVICE OPTION - POSITIONING THE FRAME ASSEMBLY

### **MACHINE CONDITION:**

Unimportant.

### **OBJECTIVE ADJUSTMENT:**

Coplanarity between the magnetic device door and the paper conveyor of the input slot.

### **PROCEDURE:**

Hook slots (1) on the sides of the magnetic device frame onto pins (2) on the sides of the machine. Insert the two securing screws (3).

Push the magnetic device frame upwards until it rests against the paper conveyor on both right and left hand sides.

Tighten the screws with a torque of 8 Kgcm.

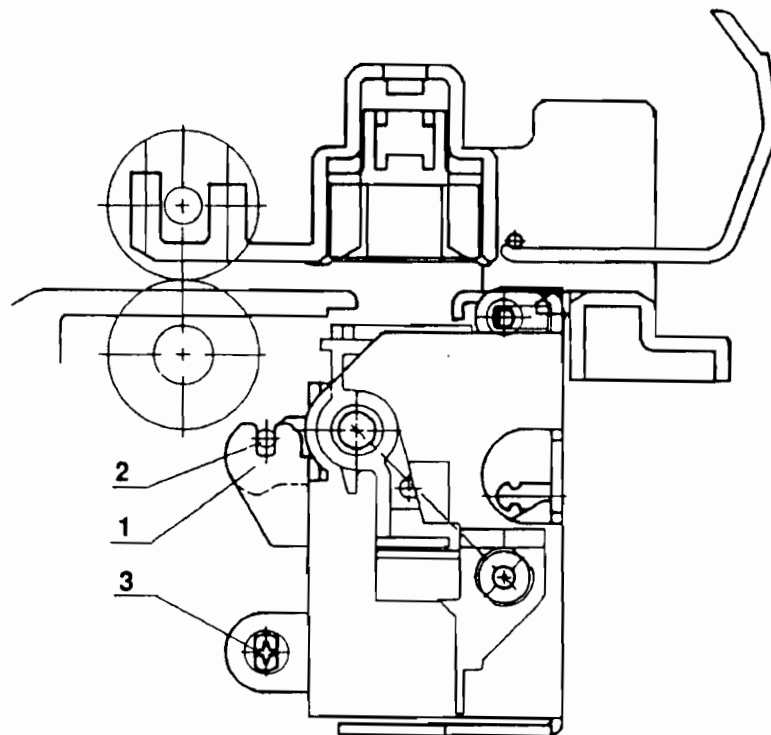
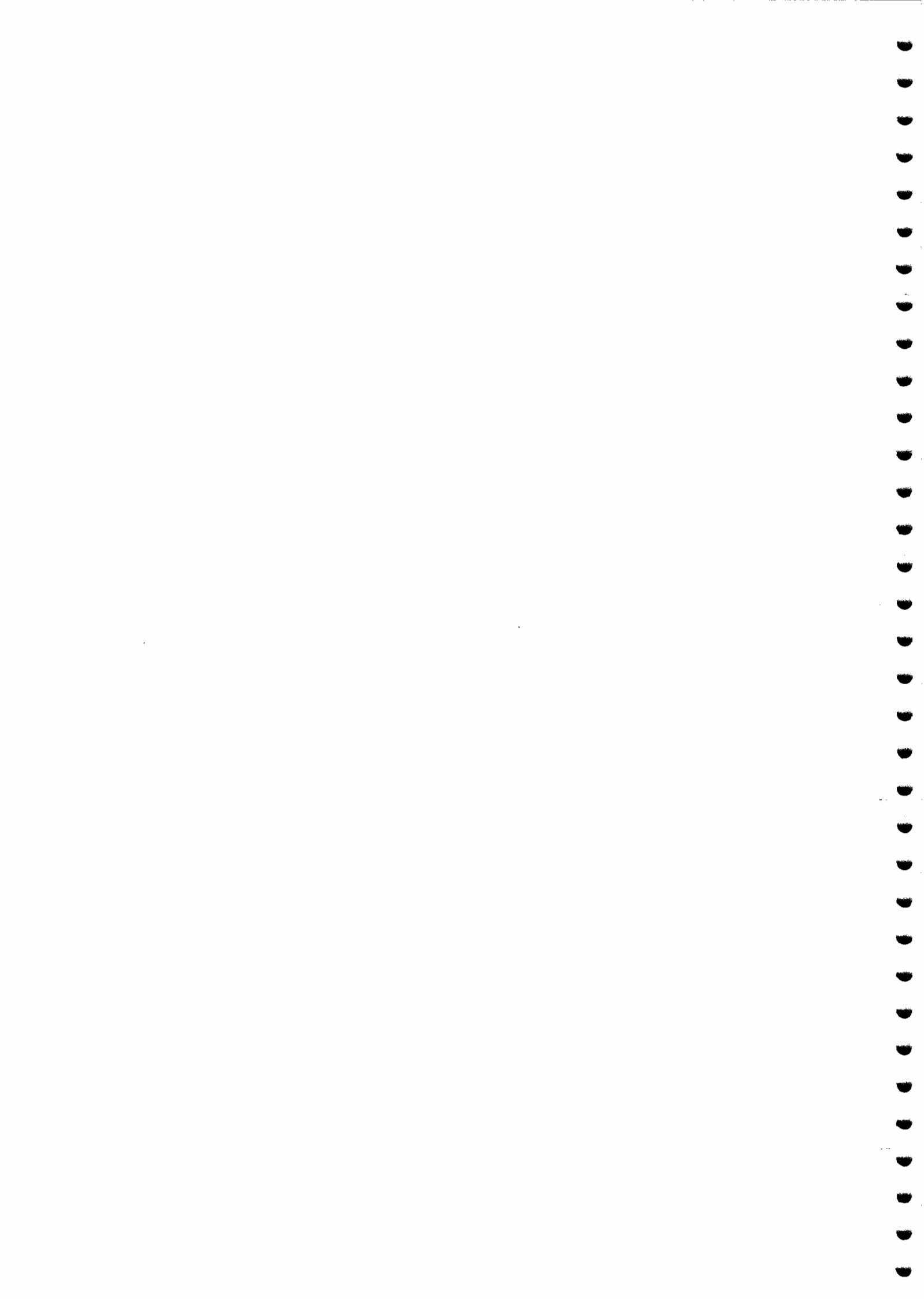


Fig. 8-14





## 9. DISASSEMBLY/REASSEMBLY

For easier consultation, the disassembly has been divided into:

- **9.2.X** Disassembling the basic machine, with no options
- **9.3.X** Disassembling the options for the basic machine (horizontal magnetic device, horizontal/MICR and vertical magnetic device)

Each disassembly is described in the following manner:

- **Reference to the previous disassembly**, in order to be able to give a backward glance at the disassembly prior to that described.
- **Operation steps** described in sequence.
- **Notes:** Any references to adjustments to be carried out after reassembly, precautions or specifications to be observed.

## 9.1 PRELIMINARY PRECAUTIONS

- To ensure the maximum safety, before starting any disassembly operation, shut down and disconnect the printer from the mains.
- All the operations should be carried out in a clean, uncluttered area.
- Follow the procedure carefully; do not unscrew parts that are not to be disassembled.
- Keep the disassembled parts in a clean place where there is no danger of losing them.
- After replacing parts, check that these have not been deformed during the assembly; if necessary restore the correct conditions.
- Re-assembly must be carried out using the same disassembly procedure in reverse.
- Before disconnecting the cables make sure to take note of their connections for reassembly.
- After servicing lubricate where specified.
- When replacing the main board, update the firmware with the latest release (section 1.11.1), run installation setup (section 4.3) and perform the electromechanical adjustments via console (section 4.4).
- When replacing the power supply board or transformer, make sure that the line voltage rating of the replacement module corresponds to the value indicated on the printer's electrical data plate.
- At the end of the service intervention run an overall check on the printer to make sure that all failures are corrected.

## 9.2 BASIC MACHINE DISASSEMBLY/REASSEMBLY PROCEDURES

### 9.2.1 DISASSEMBLING/REASSEMBLING THE CASE

- Open the printer top cover completely
- Remove the two screws (1) that secure the front part of the case and slide it off the printer by pressing on the slots (3) located above the screws (1)
- Remove the two screws (2) that secure the case to the base of the printer
- Press the four securing tabs (4) to release the case and then partly slide it off the base of the printer
- Unhook the console from the case by lifting it upwards
- Pass the console through the flat cable passage slot and remove the case from the machine.

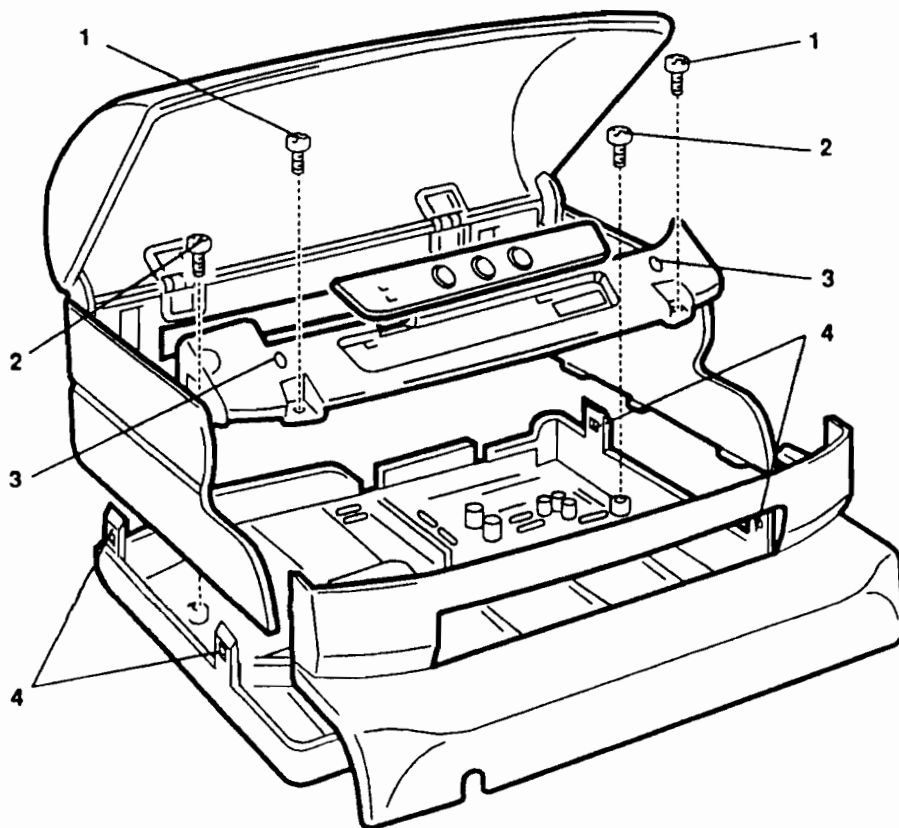


Fig. 9-1

## 9.2.2 DISASSEMBLING/REASSEMBLING THE CONSOLE

- Remove the printer case (section 9.2.1)
- Lift the entire mechanical assembly frontwards off the base of the printer and partly tilt it so as to have access to console connector (1) on the main board
- Remove the console after disconnecting the flat cable from the main board.

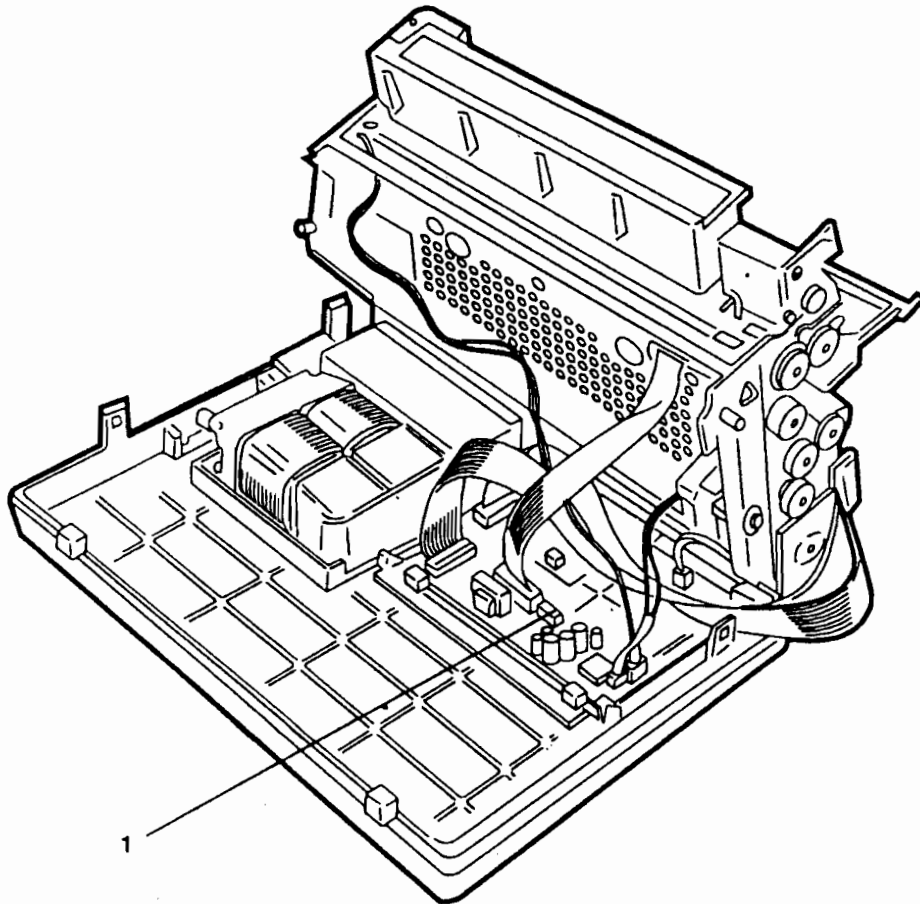


Fig. 9-2

### 9.2.3 DISASSEMBLING/REASSEMBLING THE MECHANICAL ASSEMBLY

- Remove the printer case (section 9.2.1) and the console (section 9.2.2)
- Lift the entire mechanical assembly frontwards off the base of the printer and partly tilt it so as to have access to the connectors on the main board
- Disconnect all the cables connecting the mechanical assembly to the main board
- From the base of the printer remove screw (1) that secures the mechanical assembly ground cables
- Remove the two brackets that secure the mechanical assembly rear rubbers
- Lift the mechanical assembly off the base of the printer.

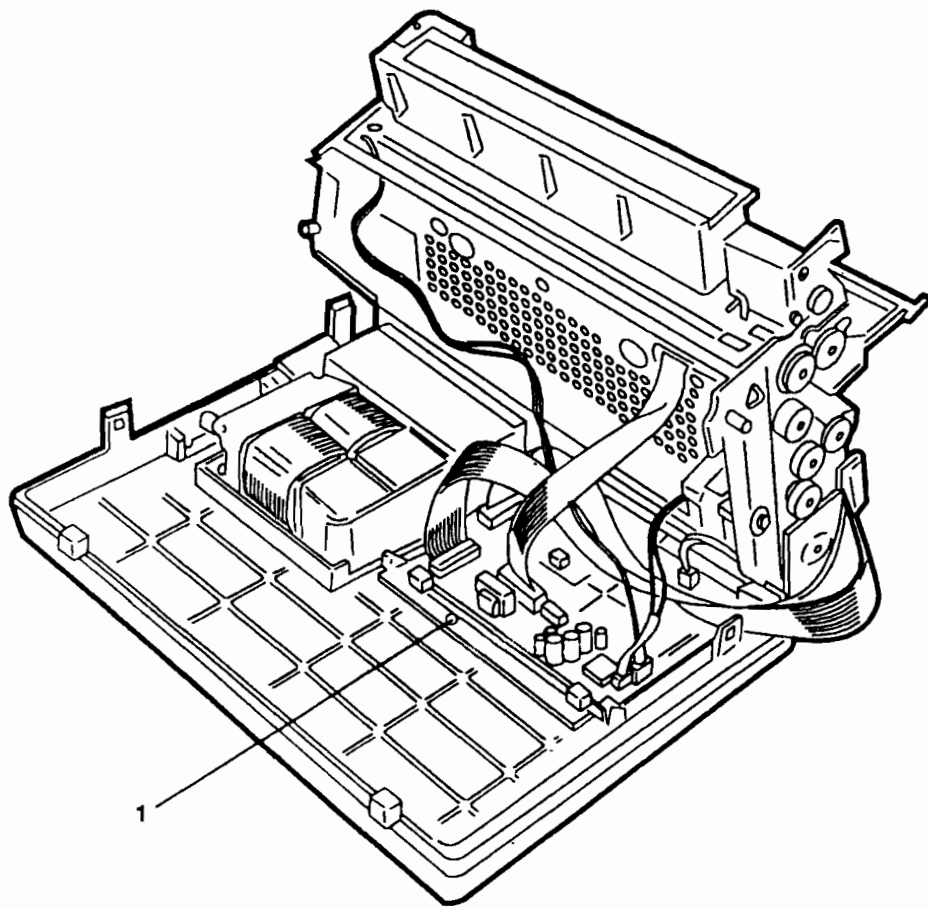


Fig. 9-3

#### 9.2.4 DISASSEMBLING/REASSEMBLING THE PRINT HEAD FLAT CABLE

- Remove the printer case (section 9.2.1)
- Lift the entire mechanical assembly frontwards off the base of the printer and partly tilt it so as to have access to the connectors on the main board
- Disconnect the flat cables that connect the print head to the main board
- Release the flat cables from the cable clip (1) located on the left-hand side of the frame
- Remove screw (2) that secures the rear cable clip (3), turn this clip and release the flat cables
- Turn upwards the flat cable support attached to the print head (4) as far as it goes.
- Disconnect the flat cables from the print head connectors
- Release the flat cables from support (4).

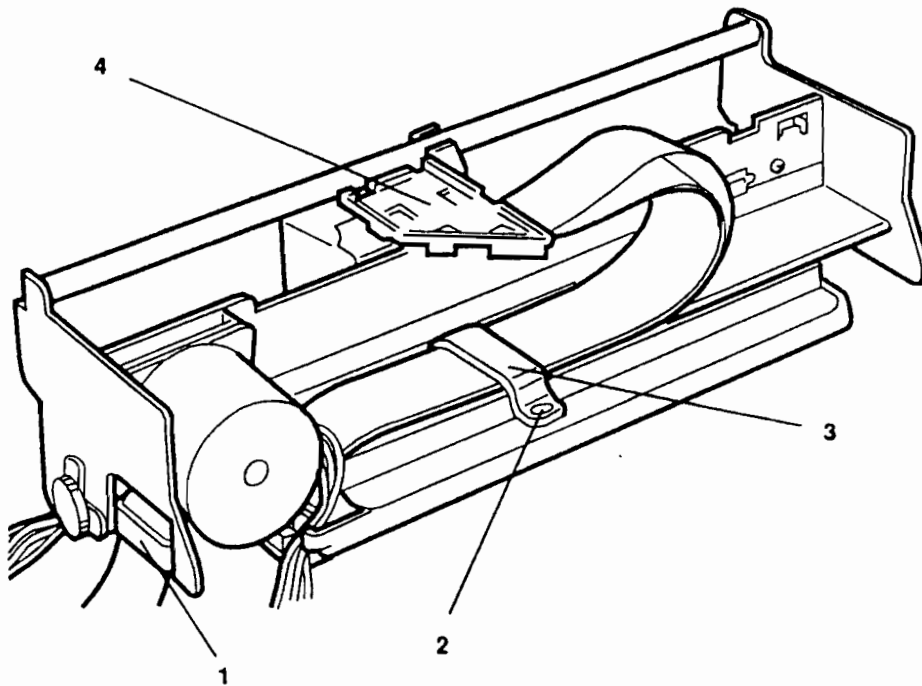


Fig. 9-4

### 9.2.5 DISASSEMBLING/REASSEMBLING THE UPPER MECHANICAL ASSEMBLY

- Remove the printer case (section 9.2.1) and console (section 9.2.2)
- Lift the entire mechanical assembly frontwards off the base of the printer and partly tilt it so as to have access to the connectors on the main board
- Disconnect the cables that connect the print head and transport motor to the main board
- Lift the upper mechanical assembly using the corresponding lever
- Loosen the two rear side hinge pins (1) so as to be able to disconnect the upper mechanical assembly.

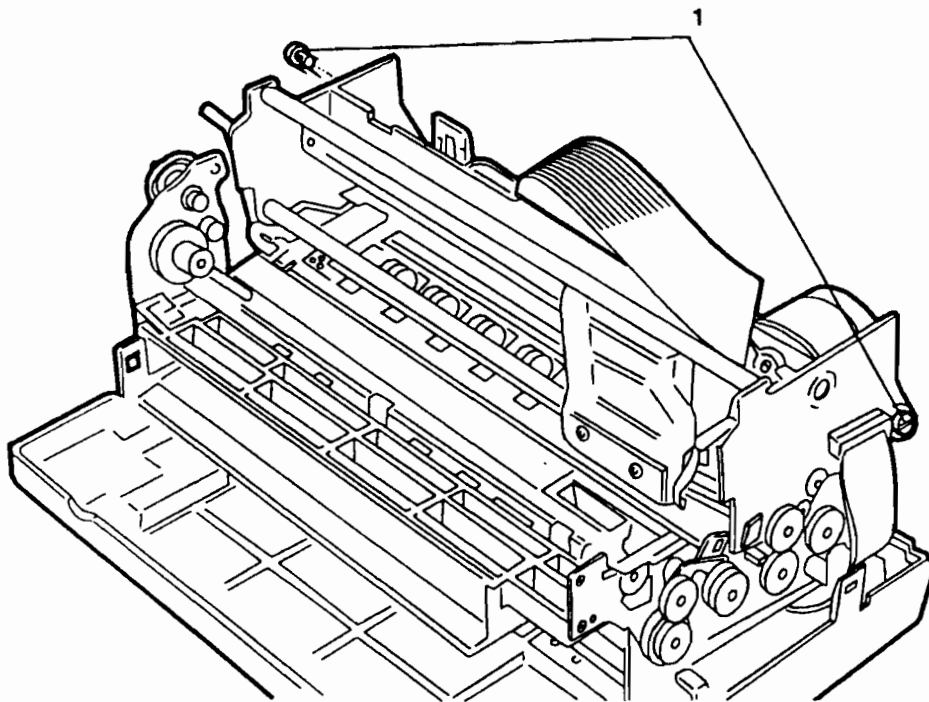


Fig. 9-5

**Note:** Check the adjustment of the roller gears during reassembly (section 8.1.7).



## 9.2.6 DISASSEMBLING/REASSEMBLING THE PRINT HEAD

- Open the printer cover and lift the upper mechanical assembly
- Remove the ribbon cartridge from the printer
- Loosen the two screws (1) that secure the print head
- Partly lift the print head from the carriage and disconnect the electrical power supply flat cable
- Remove the print head from its slide after removing the two front screws (2) and then remove the probe roller
- Remove the two side screws (3) and remove the ribbon protection fin
- Remove the rear screw (4), detach connector (5) and remove the paper photosensor.

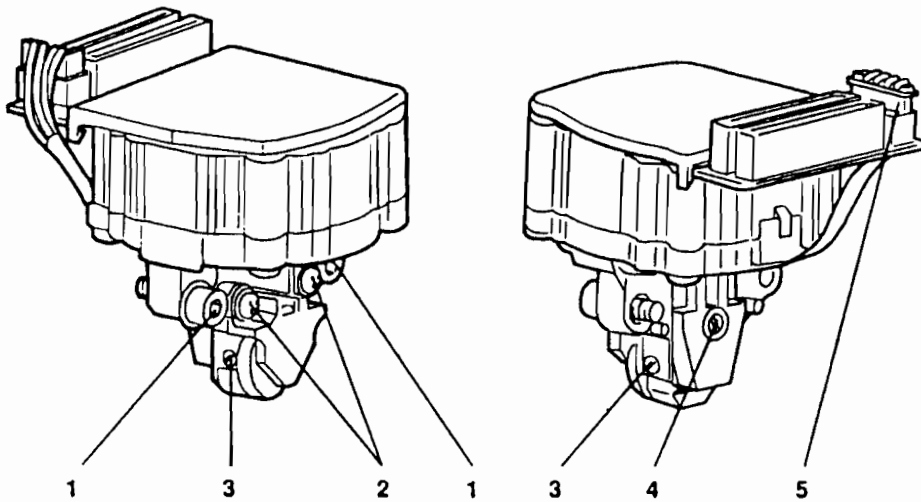


Fig. 9-6

**Note:** To attach the flat cables to the print head connectors, first release the cables from the cable guide block and then secure them in place again once attached.  
Perform the following adjustments during reassembly: 8.1.2 (platen-needle distance), 8.1.3 (needle-ribbon protection fin distance), 8.1.4 (paper photosensor position).

### 9.2.7 DISASSEMBLING/REASSEMBLING THE PAPER FEED MOTOR

- Remove the mechanical assembly (section 9.2.3)
- Loosen the two nuts (1) that secure the motor and release the document feed belt. If the right vertical magnetic option is present, remove the noise prevention metal shield from the motor by removing its two securing screws
- Remove the nuts and extract the motor.

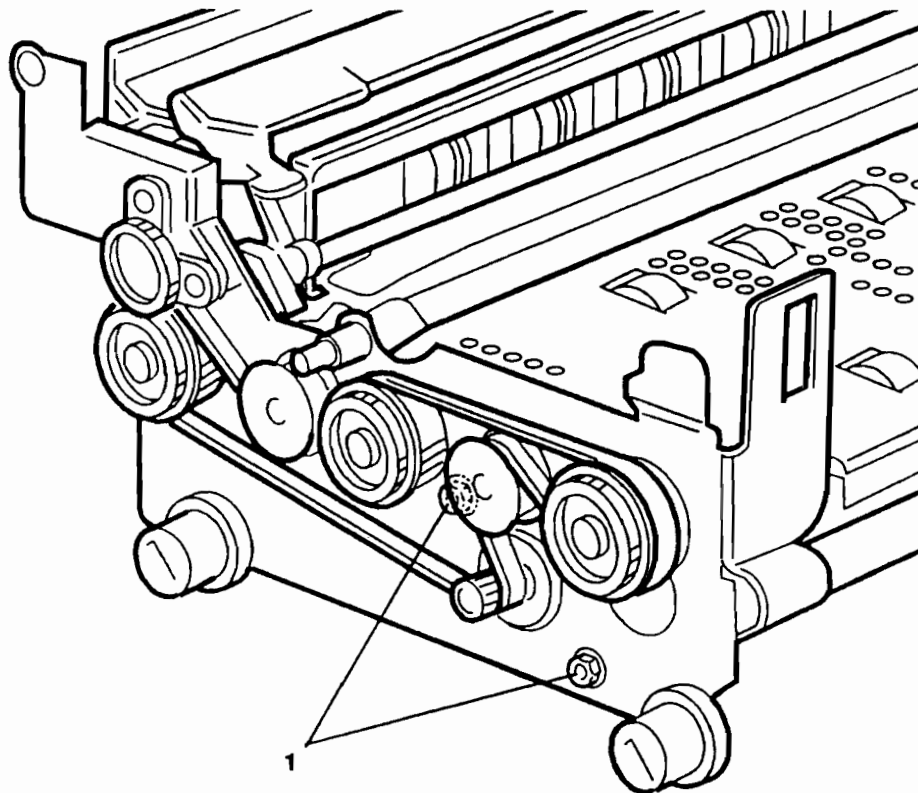


Fig. 9-7

**Note:** Adjust the tension of the document feed belt during reassembly (section 8.1.1).

## 9.2.8 DISASSEMBLING/REASSEMBLING THE PRINT HEAD MOVEMENT MOTOR

- Remove the upper mechanical assembly (section 9.2.4)
- Loosen screw (1) that secures the return pulley support slide and release the slide movement belt from the motor pinion
- Loosen the three special securing screws (2) and remove the print head movement motor being careful not to damage the ribbon feed gears.

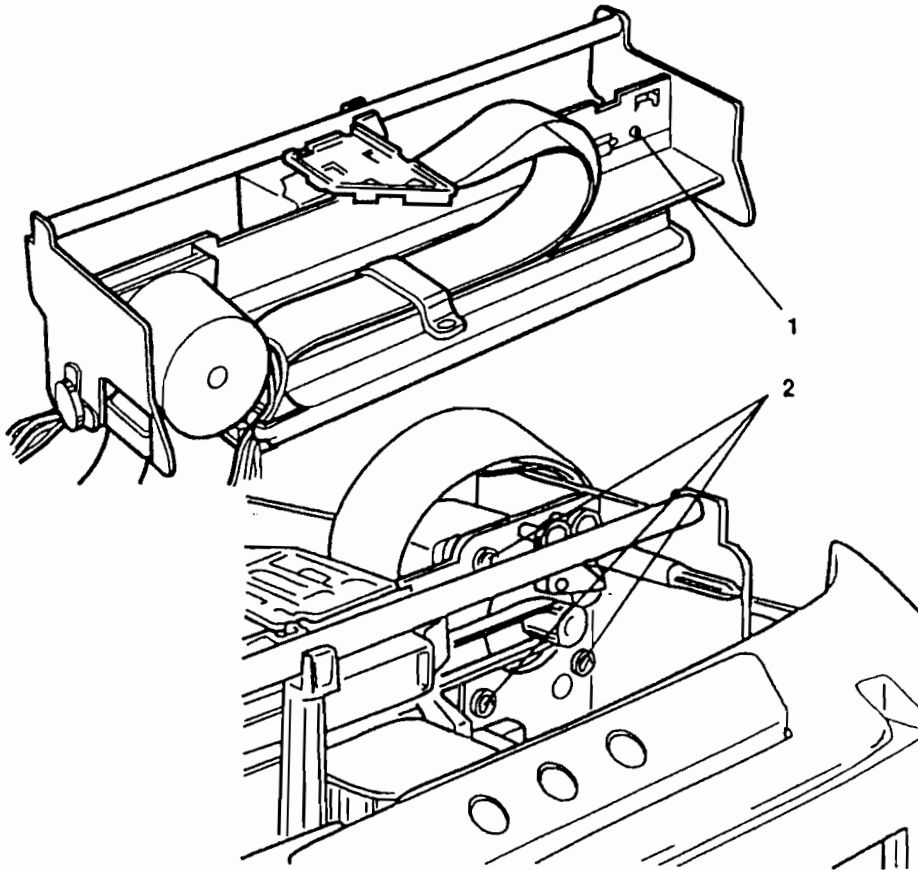


Fig. 9-8

**Note:** Check the tension of the slide movement belt during reassembly (8.1.10).

### 9.2.9 DISASSEMBLING/REASSEMBLING THE SERVICES MOTOR

- Remove the printer case (section 9.2.1)
- Lift the entire mechanical assembly frontwards off the base of the printer and partly tilt it so as to have access to the connectors on the main board
- Disconnect the services motor connection cable from the main board
- Remove the two screws (1) that secure the motor to the left-hand side of the frame and remove the motor from the printer.

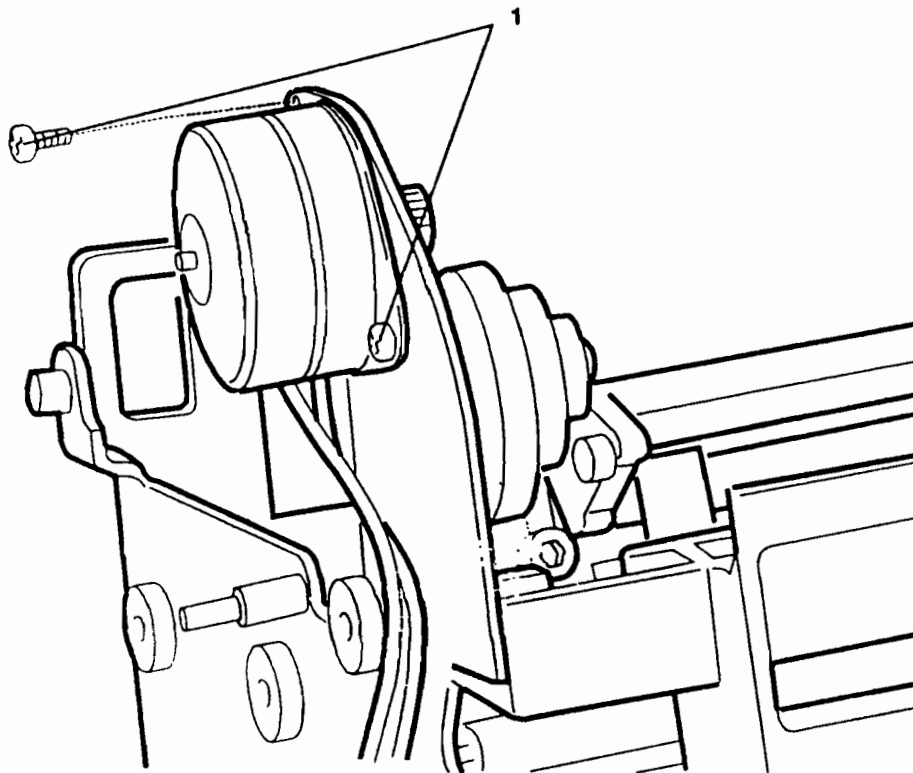


Fig. 9-9

## 9.2.10 DISASSEMBLING/REASSEMBLING THE FEEDER PHOTOSENSORS

- Remove the mechanical assembly (section 9.2.3)
- Separate the lower part of the mechanics from the upper part (9.2.4)
- Unhook the two springs (2) and slide the document stop bar off its guides
- Remove the two screws (3) that secure the support crosspiece and remove this part
- Remove the remaining two securing screws (5) and free the photosensor support (6)
- Remove elastic clamp (7) that secures bushing (8) axially
- Slide off bushing (8) and remove the photosensor support after lowering the rollers shaft.

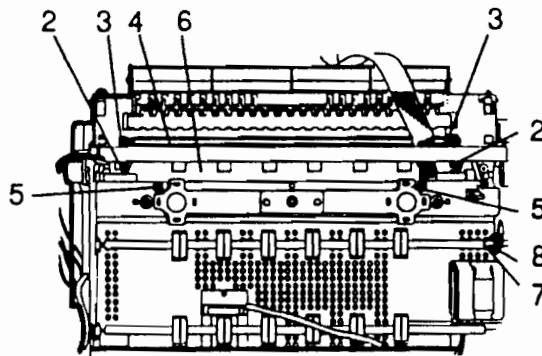
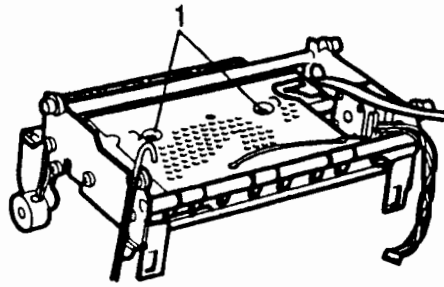


Fig. 9-10

**Note:** During reassembly proceed with adjustments 8.1.6 (Tab Adjustments), 8.1.8 (Front Pressure Roller Adjustments), 8.1.9 (Tab Opening Adjustments). Proceed with adjustment 4.4 (Photosensor Calibration) at the end of reassembly.

### 9.2.11 DISASSEMBLING/REASSEMBLING THE REAR PHOTSENSOR

- Remove the mechanical assembly (section 9.2.3)
- Remove the rear protection shield after removing the two screws (1)
- Remove the rear photosensor flat cable by releasing the two plates (2) that are snapped into the plastic supports.

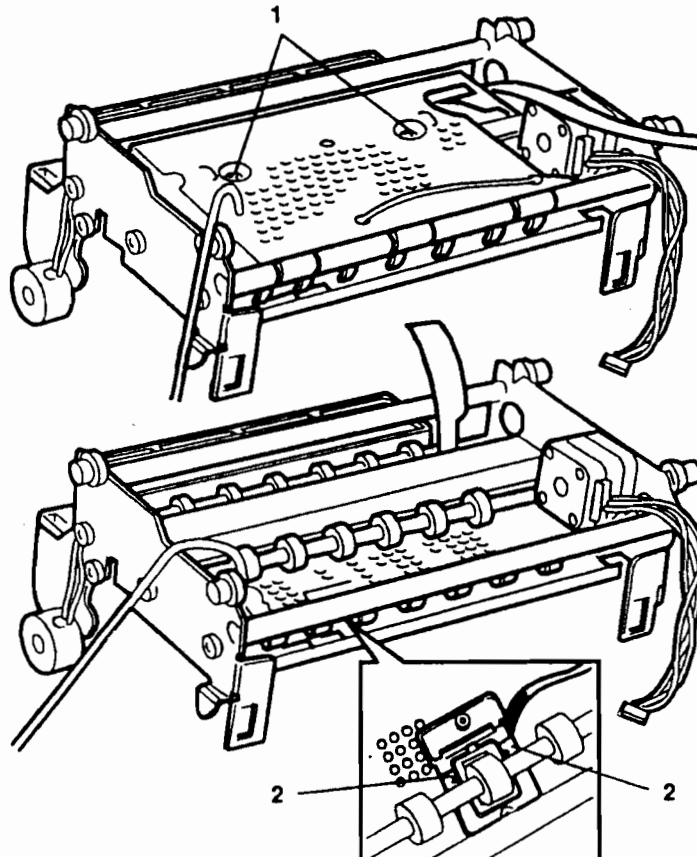
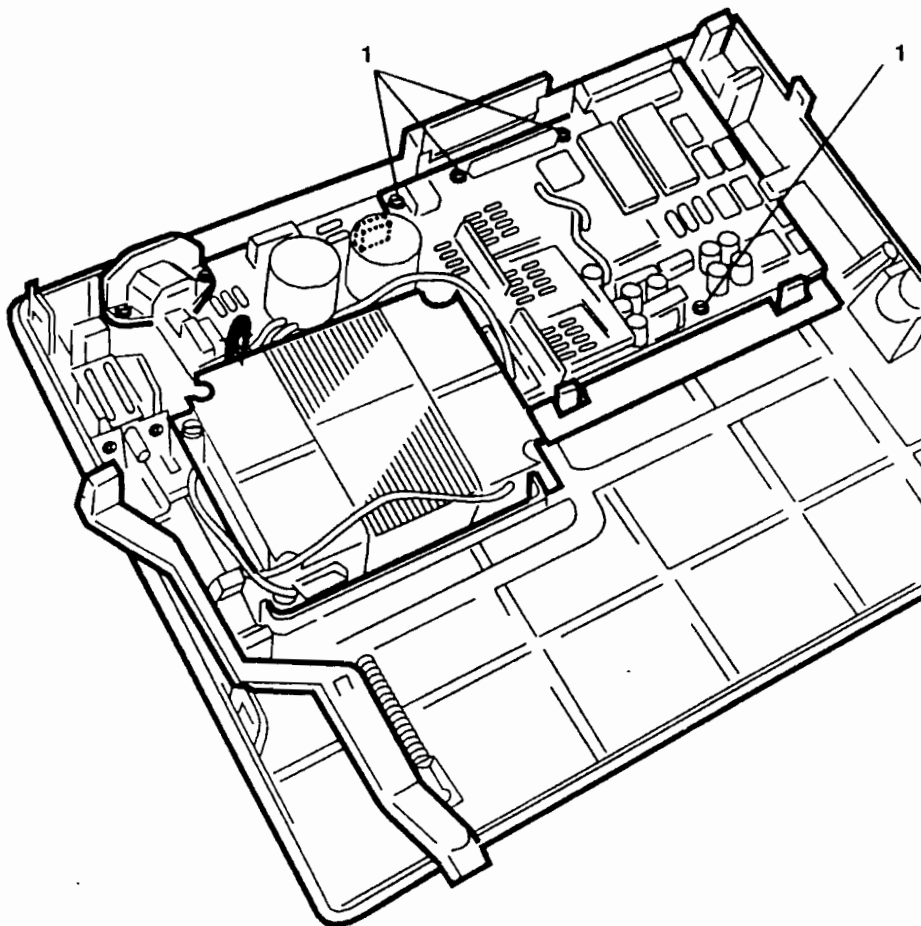


Fig. 9-11

**Note:** If the photosensor is replaced, proceed with adjustment 4.4. (Photosensor Adjustment) at the end of reassembly.

## 9.2.12 DISASSEMBLING/REASSEMBLING THE MAIN BOARD

- Remove the mechanical assembly (section 9.2.3)
- Disconnect the power supply cable that connects the main board to the line voltage unit
- Remove the four securing screws (1) and remove the main board.

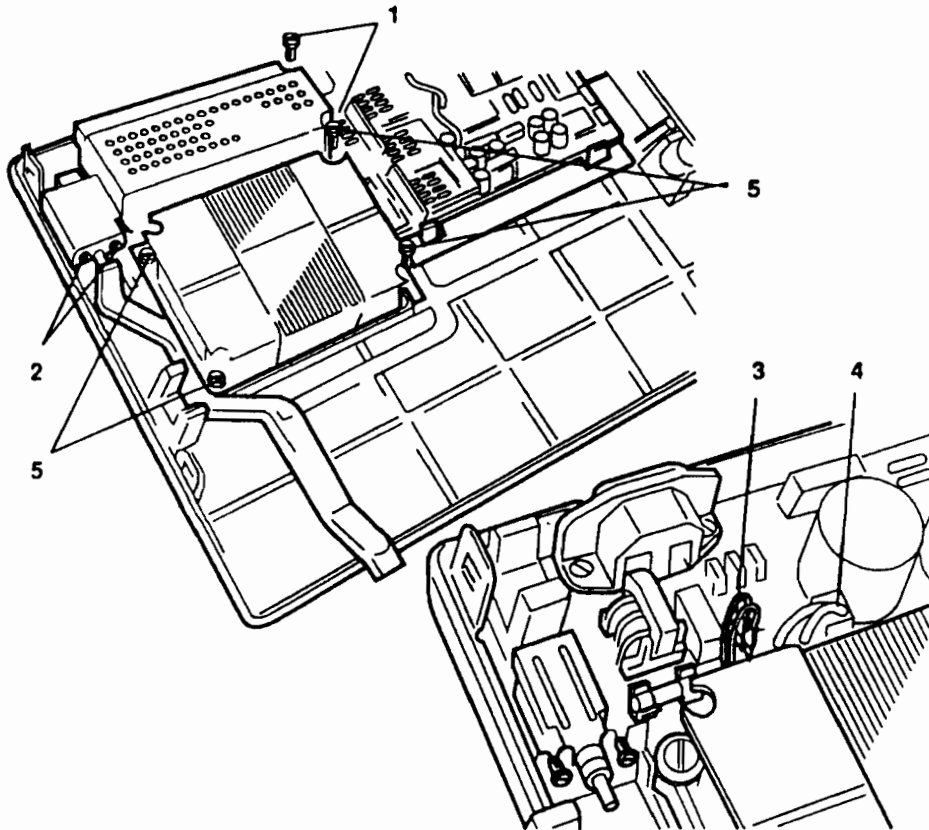


*Fig. 9-12*

**Note:** If the board is replaced, update the firmware to the latest release (section 1.11.1), run installation setup (section 4.3) and adjust the photosensors (section 4.4).

### 9.2.13 DISASSEMBLING/REASSEMBLING THE TRANSFORMER

- Remove the mechanical assembly (section 9.2.3)
- Remove the cover of the power assembly after removing the two screws (1) and loosening the two screws (2)
- Disconnect transformer coil cables (3) and (4) from the power assembly board
- Remove the four screws (5) and remove the transformer.



*Fig. 9-13*

**Note:** If the transformer is replaced, make sure the new transformer has the same power requirements as the one replaced.



## 9.2.14 DISASSEMBLING/REASSEMBLING THE TOROIDAL TRANSFORMER

- Remove the mechanical assembly (section 9.2.3)
- Remove the cover of the power assembly as explained previously
- Disconnect wires (1) and (2) of the transformer windings from the power assembly board
- Remove the two screws securing the shield (3) and remove it
- Remove the four screws (4) and then remove the transformer.

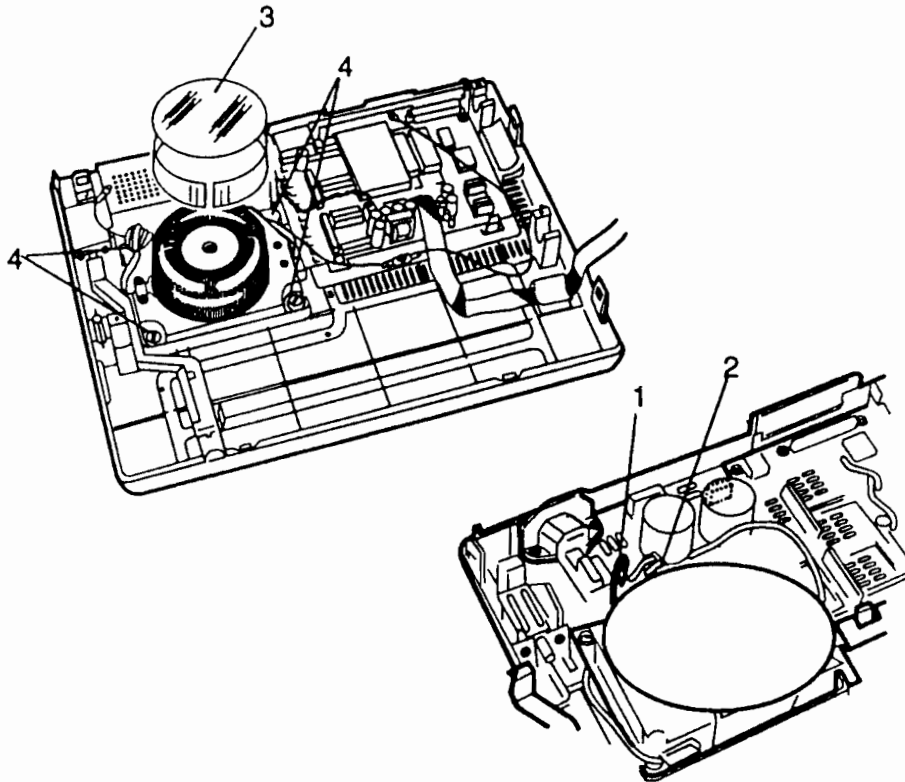
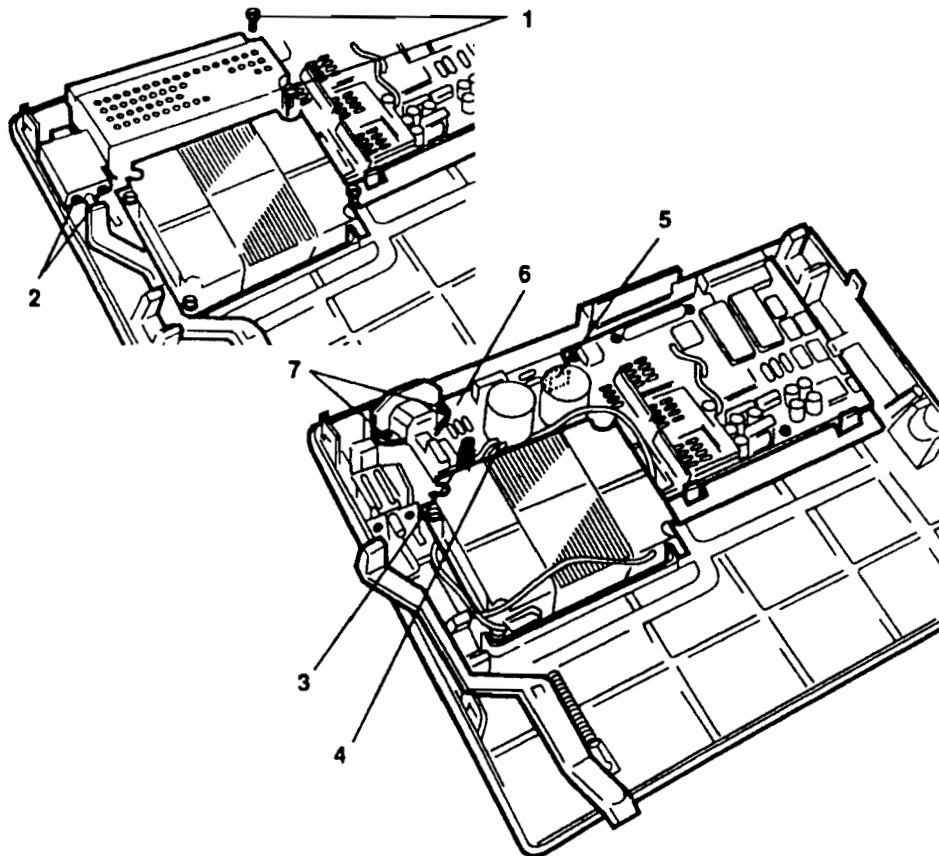


Fig. 9-14

**Note:** If the transformer is replaced, make sure the new transformer has the same power requirements as the one replaced.

## 9.2.15 DISASSEMBLING/REASSEMBLING THE POWER ASSEMBLY

- Remove the mechanical assembly (section 9.2.3)
- Remove the cover of the power assembly after removing the two screws (1) and loosening the two screws (2)
- Disconnect transformer coil cables (3) and (4) from the power assembly board and connection cable (5) from the main board
- Remove ground screw (6)
- Remove screws (7) and then remove the power assembly.



*Fig. 9-15*

**Note:** If the board is replaced, make sure that the new board has the same power requirements as the one replaced.

## 9.2.16 REPLACING THE FUSE

- Remove the mechanical assembly (section 9.2.3)
- Remove the cover of the power assembly after removing the two screws (1) and loosening the two screws (2)
- Replace fuse (3).

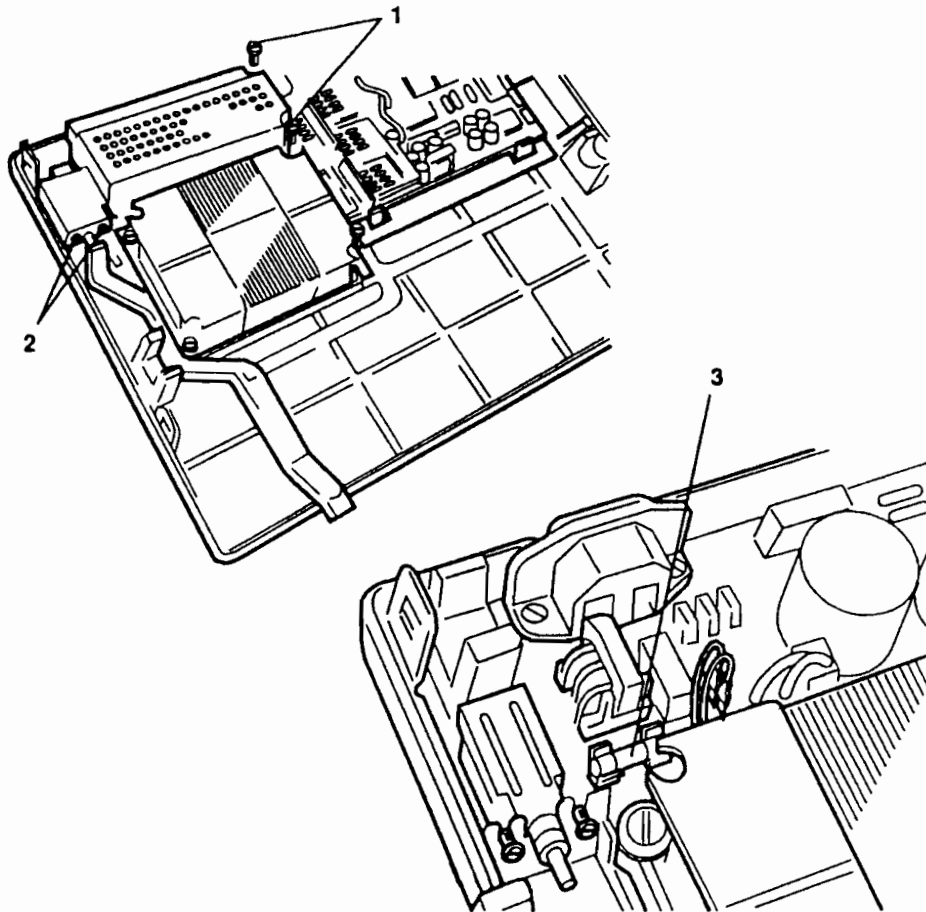


Fig. 9-16

**Note:** Make sure that the new fuse has the same electrical characteristics as the one replaced.

## 9.3 BASIC MACHINE OPTIONS DISASSEMBLY/REASSEMBLY PROCEDURES

### 9.3.1 DISASSEMBLING/REASSEMBLING THE HORIZONTAL MAGNETIC DEVICE AND MICR ASSEMBLY

- Remove the printer case (section 9.2.1)
- Lift the entire mechanical assembly frontwards off the base of the printer and partly tilt it so as to have access to the connectors on the magnetic device board (1)
- Detach the connectors of the horizontal magnetic device assembly from the magnetic device board
- Remove the two screws (2) that secure the assembly to the printer frame and remove the option.

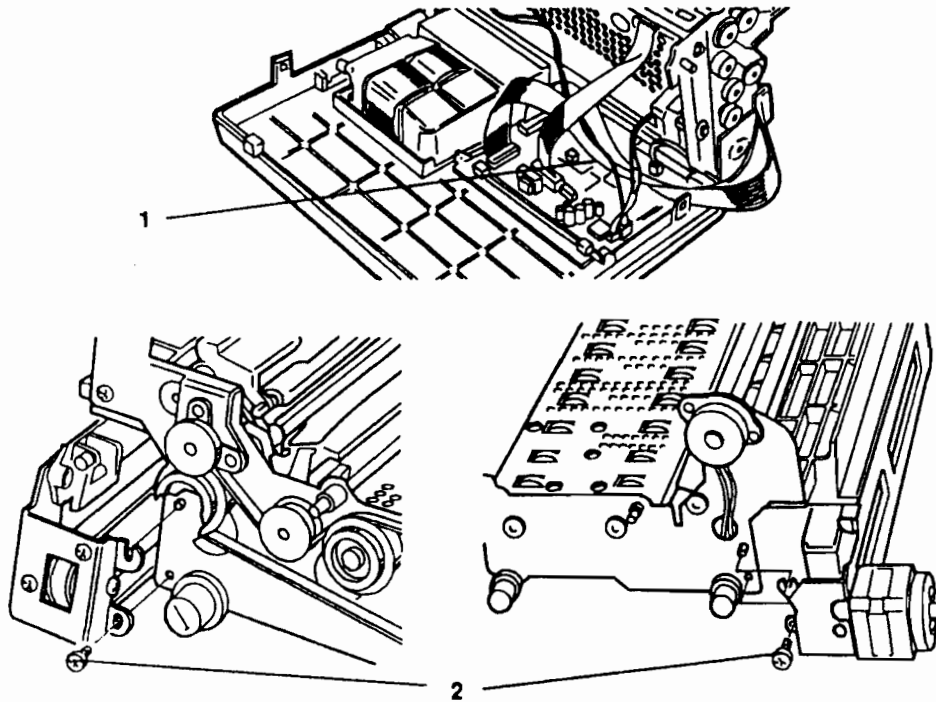


Fig. 9-17

**Note:** Proceed with adjustment 8.2.4 (Frame Assembly Positioning) during reassembly.

### 9.3.2 DISASSEMBLING/REASSEMBLING THE VERTICAL MAGNETIC HEAD

- Remove the mechanical assembly (section 9.2.3)
- Separate the lower mechanical assembly from the upper assembly (section 9.2.4)
- Remove the lower protection shield after removing the two screws (1)
- Remove the vertical magnetic head after removing the three screws (2).

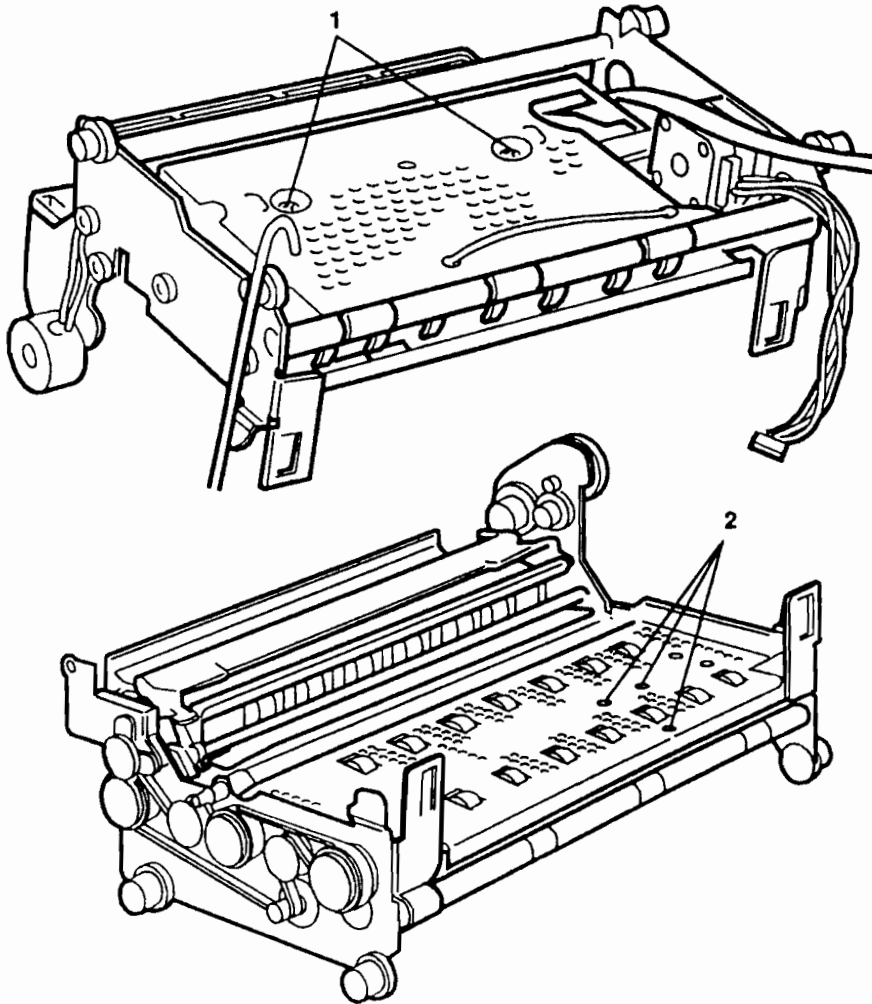
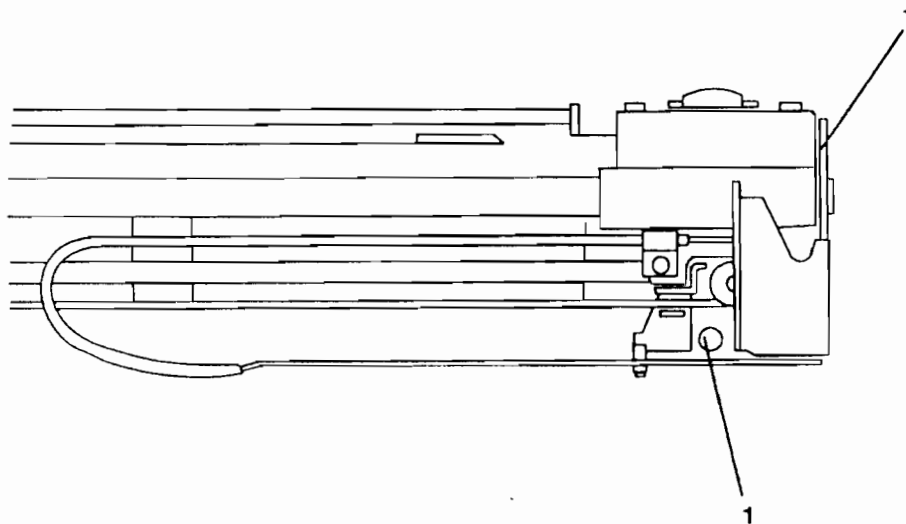


Fig. 9-18

## 9.4 CHECK READER OPTION DISASSEMBLY/REASSEMBLY

### 9.4.1 DISASSEMBLING/REASSEMBLING THE CHECK MODULE SERVICES MOTOR

- Remove the case and assembly (section 9.3.1)
- Disconnect the cable motor from the board
- Loosen the two nuts (1) and remove the motor with related protection shield.



*Fig. 9-19*

#### 9.4.2 DISASSEMBLING/REASSEMBLING THE MICR HEAD ASSEMBLY

- Remove the case and assembly (section 9.3.1)
- Loosen screw (1) and free the signals cable
- Loosen screws (2) and remove the MICR head (3).

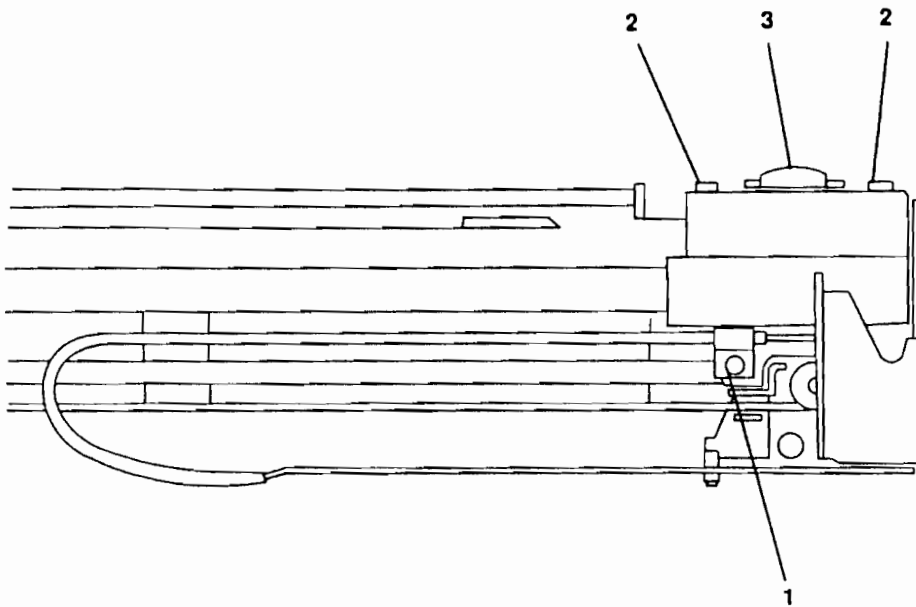
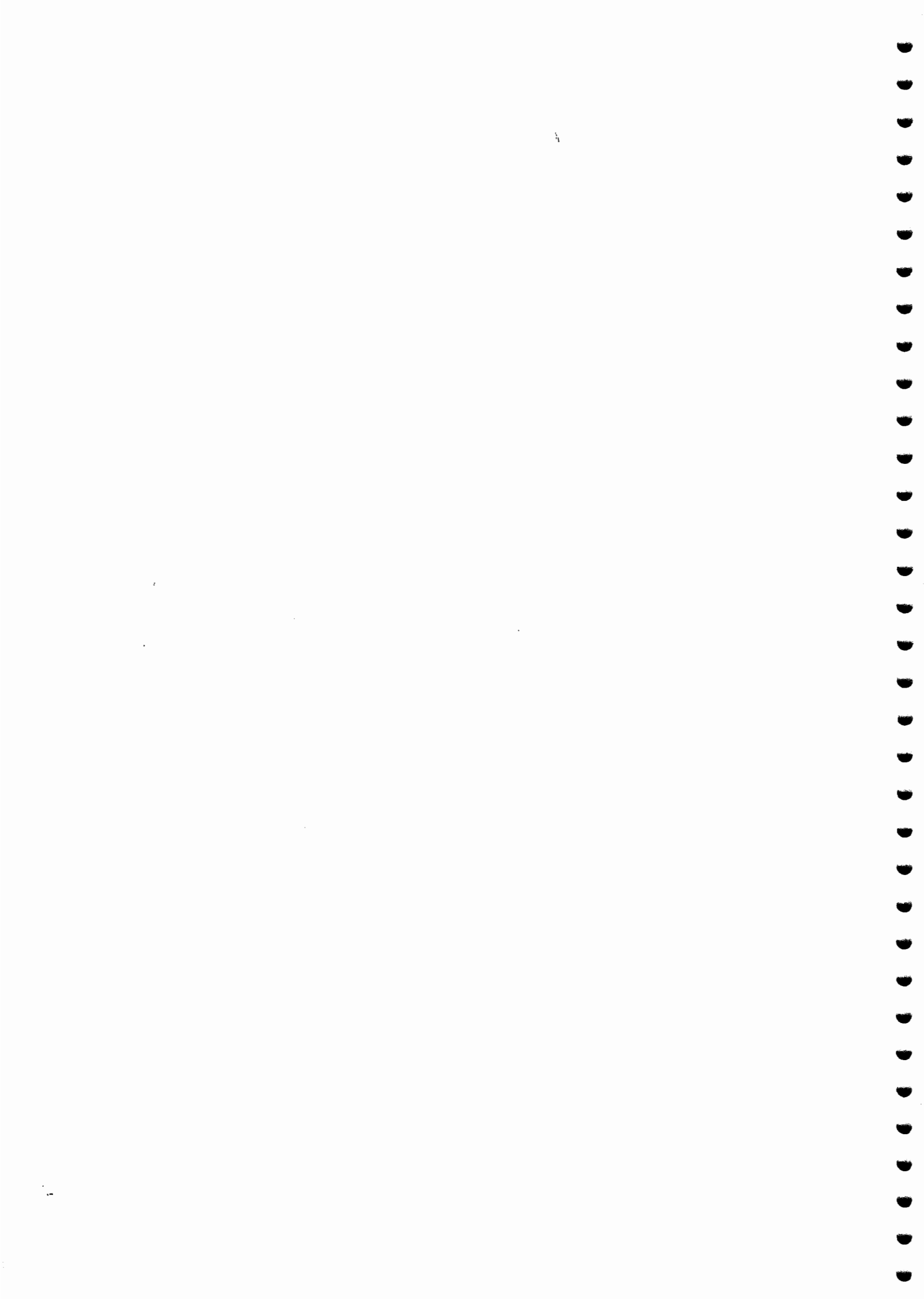


Fig. 9-20







**STAMPANTE - PRINTER**

**PR 2**

**CATALOGO PARTI DI RICAMBIO  
SPARE PARTS CATALOGUE**

Code 2720972F-02

---

**IMPORTANTE**

PUBBLICAZIONE REDATTA DA OLIVETTI LEXIKON (GESTIONE RICAMBI E SCORTE).  
QUESTO CATALOGO È L' UNICO DOCUMENTO AL QUALE FARE RIFERIMENTO PER  
ORDINARE LE PARTI DI RICAMBIO.

PER EVENTUALI INFORMAZIONI RIVOLGERSI AL NUMERO:  
FAX: +39.125.524025

**IMPORTANT**

THIS PUBLICATION IS WRITTEN BY OLIVETTI LEXIKON (SPARE PARTS DEPARTMENT).  
THIS CATALOGUE IS THE ONLY DOCUMENT TO WHICH REFERENCE MAY BE MADE  
FOR ORDERING SPARE PARTS.

REQUESTS FOR ADDITIONAL INFORMATION SHOULD BE FAXED TO THE FOLLOWING  
NUMBER:  
FAX: +39.125.524025.

---

**PUBBLICAZIONE EMESSA DA:**  
**PUBLICATION ISSUED BY:**

**Olivetti Lexikon, S.p.A.**  
Documentazione  
77, Via Jervis - 10015 Ivrea (Italy)

*Copyright © 1997, by Olivetti*  
*All rights reserved*

*Printed in Italy by:*

**INDICE****PR2/S10 MACCHINA BASE**

COMPLESSIVO .....	Pag. 3
CARROZZERIA .....	" 4
GRUPPO FONDELLO E ALIMENTATORE .....	" 6
GRUPPO STRUTTURA INFERIORE .....	" 8
GRUPPO PRESSORI POSTERIORI .....	" 14
GRUPPO STAMPA .....	" 16

**PR2/S12**

COMPLESSIVO .....	Pag. 19
GRUPPO STRUTTURA INFERIORE CON MAGN. ORIZZ. ....	" 20
GRUPPO MAGNETICO ORIZZONTALE .....	" 22

**PR2/S13**

COMPLESSIVO .....	Pag. 25
GRUPPO FONDELLO E ALIMENTATORE .....	" 26
GRUPPO STRUTTURA INFERIORE .....	" 28
GRUPPO PRESSORI POSTERIORI .....	" 30
GRUPPO MAGNETICO VERTICALE .....	" 32

**PR2/S12 M**

COMPLESSIVO .....	Pag. 33
GRUPPO STRUTTURA INFERIORE CON MAGN. ORIZZ. + MICR .....	" 34
GRUPPO MAGNETICO ORIZZONTALE + MICR .....	" 36

**PIASTRE ELETTRONICHE MOD. PR2/S10-PR2/S12-PR2/S12 M-PR2/S13**

PIASTRE ELETTRONICHE .....	" 40
MINUTERIA .....	" 42

INDICE GENERALE DEI CODICI .....	Pag. 43
----------------------------------	---------

**INDEX****STANDARD PR2/S10 VERSION**

OVERVIEW .....	Pag.	3
CASING .....	"	4
BASE UNIT AND POWER SUPPLY .....	"	6
LOWER SECTION GROUP .....	"	8
REAR PRESSURE UNIT .....	"	14
PRINTING UNIT .....	"	16

**PR2/S12**

OVERVIEW .....	Pag.	19
LOWER SECTION WITH HORIZ. MAGN. DEVICE .....	"	20
HORIZONTAL MAGNETIC READING DEVICE .....	"	22

**PR2/S13**

OVERVIEW .....	Pag.	25
BASE UNIT AND POWER SUPPLY .....	"	26
LOWER SECTION GROUP .....	"	28
REAR PRESSURE UNIT .....	"	30
VERTICAL MAGNETIC DEVICE GROUP .....	"	32

**PR2/S12 M**

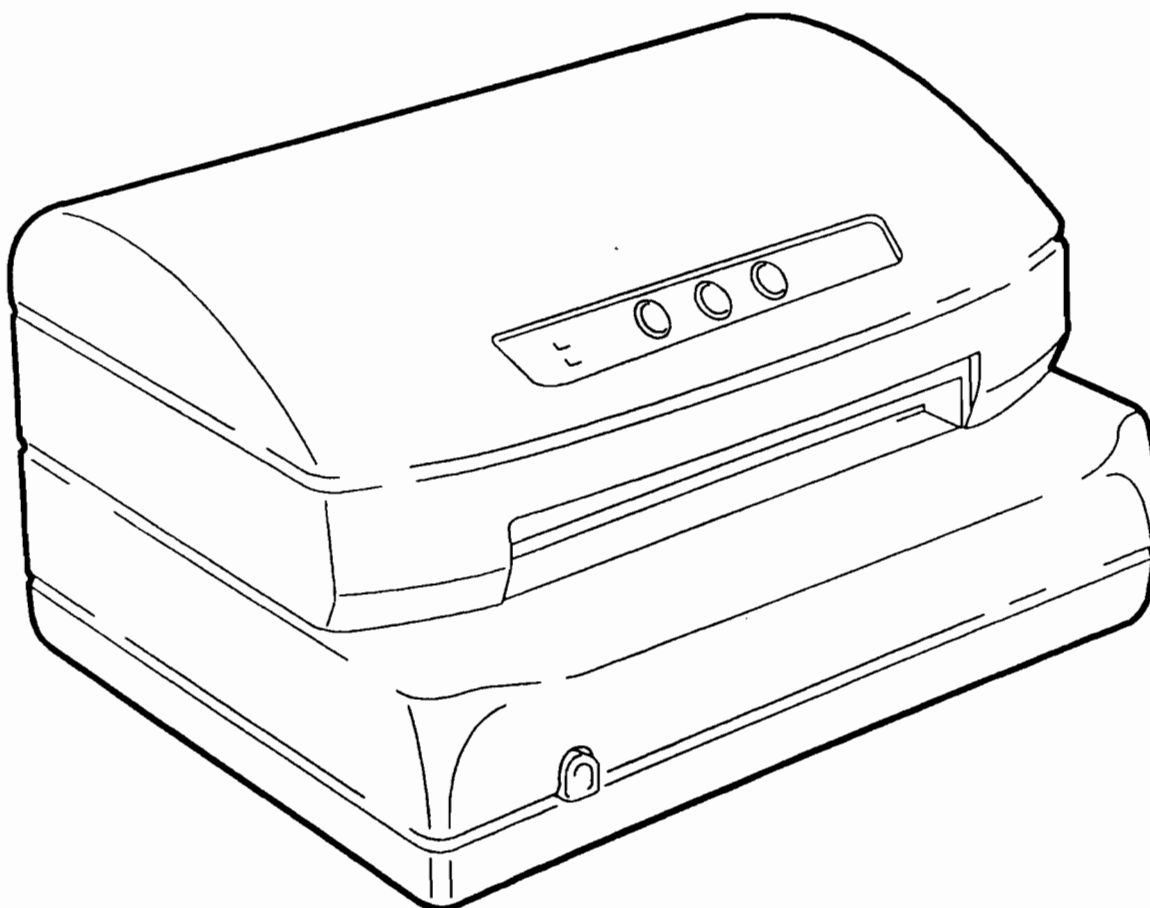
OVERVIEW .....	Pag.	33
LOWER SECTION WITH HORIZ. MAGN. DEVICE .....	"	34
HORIZONTAL MAGNETIC READING DEVICE .....	"	36

**ELECTRONIC BOARD MOD. PR2/S10-PR2/S12-PR2/S12 M-PR2/S13**

ELECTRONIC BOARD .....	"	40
DETAILS .....	"	42

<b>GENERAL INDEX .....</b>	<b>Pag.</b>	<b>43</b>
----------------------------	-------------	-----------

<b>MODELLO VERSION</b>	<b>DESCRIZIONE</b>	<b>DESCRIPTION</b>
PR2/S10	MODELLO BASE	STANDARD VERSION
PRS/S12	MODELLO BASE + MAGNETICO ORIZZONTALE	STANDARD VERSION + HORIZONTAL MAGNETIC DEVICE
PR2/S12M	MODELLO BASE + MAGNETICO ORIZZONTALE + MICR	STANDARD VERSION + HORIZONTAL MAGNETIC DEVICE + MICR
PR2/S13	MODELLO BASE + MAGNETICO VERTICALE	STANDARD VERSION + VERTICAL MAGNETIC DEVICE

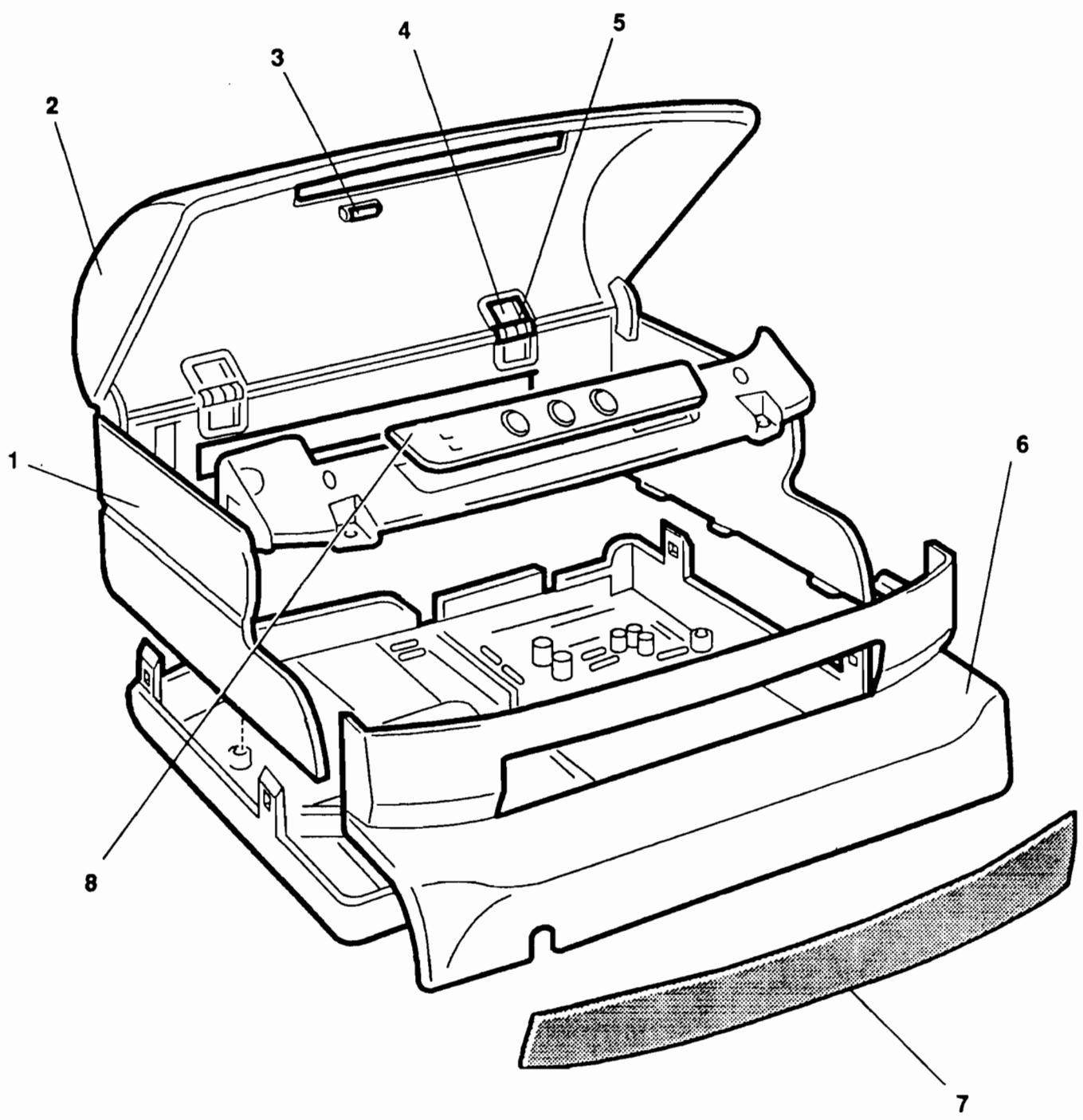


**PR2/S10 - MACCHINA BASE**

**PR2/S10 - STANDARD VERSION**

**CARROZZERIA  
CASING****PR2/S10**

REF.	CODE	DESCRIZIONE	DESCRIPTION
1	474468 A	GRUPPO SCOCCA	BODY ASSEMBLY
2	474469 B	GRUPPO COPERTURA SUPERIORE	UPPER COVER ASSEMBLY
3	752610 J	MAGNETE PER COPERTURA	COVER MAGNET
4	473540 D	CERNIERA	HINGE
5	759410 R	PERNO PER CERNIERA	HINGE FOR PIN
6	474471 V	GRUPPO FRONTALE	FRONT SECTION ASSEMBLY
7	473506 Y	FONOASSORBENTE ANTERIORE	FRONT DEADENING
8	473539 Y	CONSOLE	CONSOLE

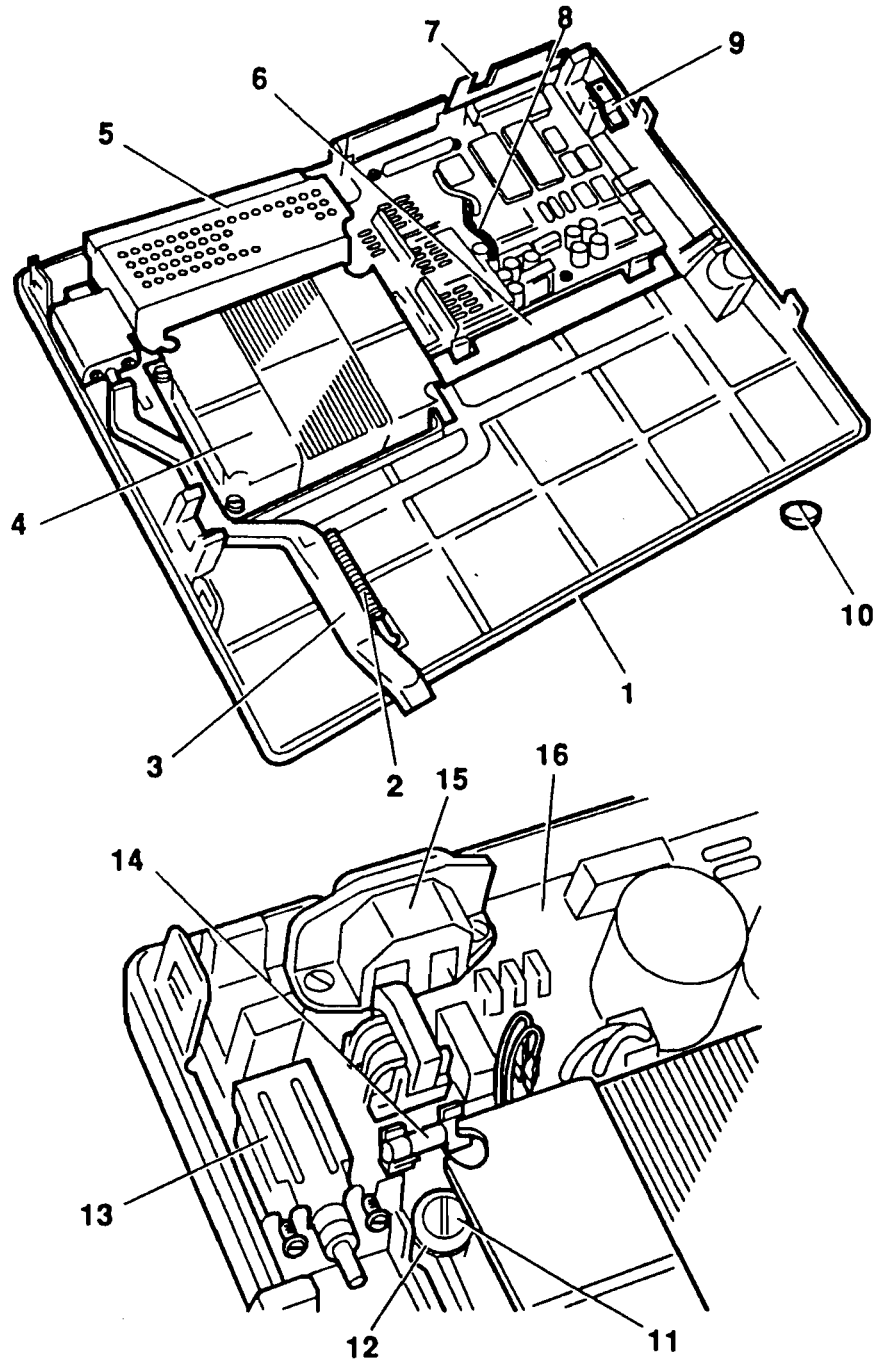




**GRUPPO FONDELLO E ALIMENTATORE  
BASE UNIT AND POWER SUPPLY**

**PR2/S10**

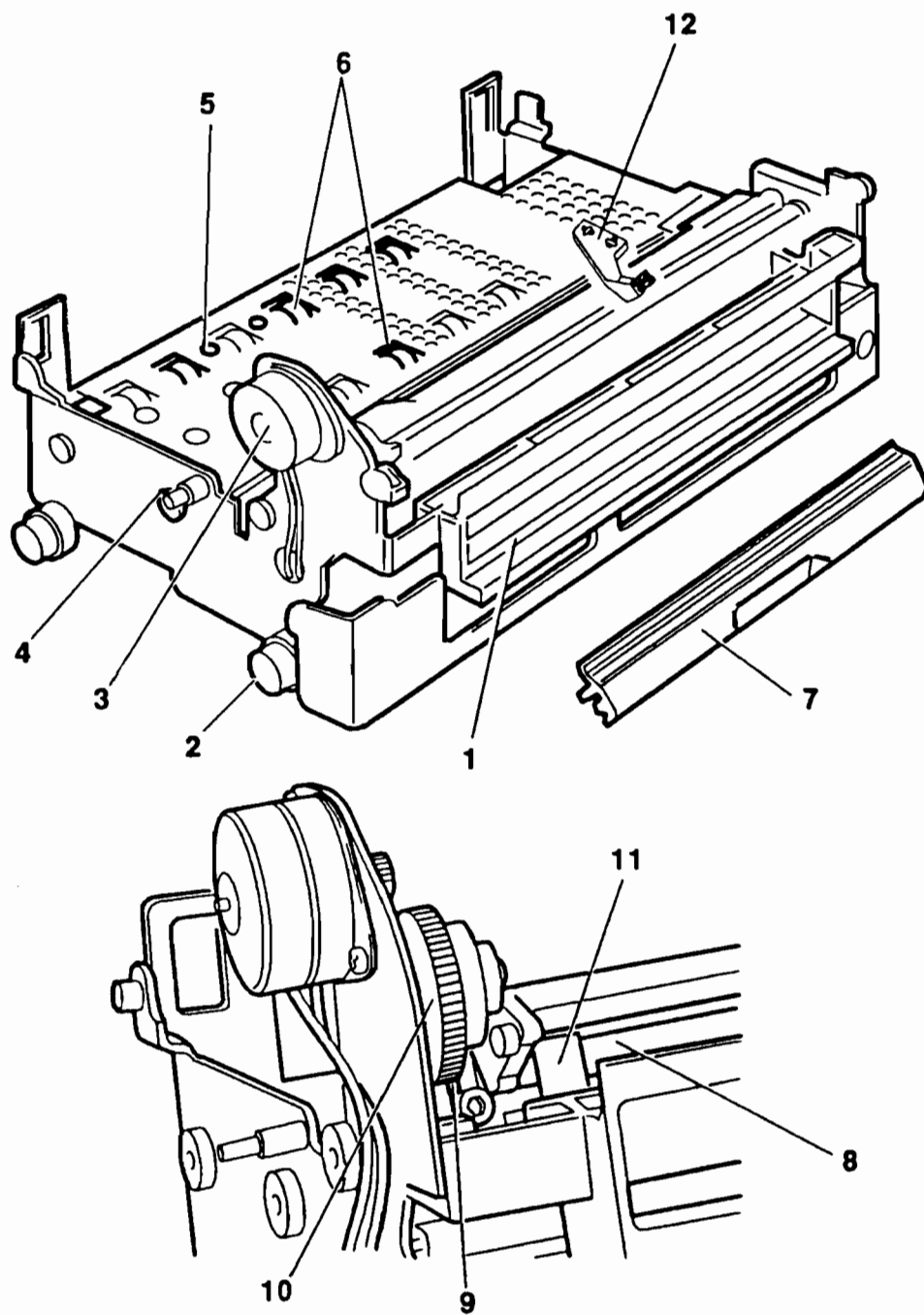
REF.	CODE	DESCRIZIONE	DESCRIPTION
1	474472 W	GRUPPO FONDELLO	BASE UNIT
2	473034 R	MOLLA CORSOIO INTERRUTTORE	SLIDING SWITCH SPRING
3	473033 Q	CORSOIO INTERRUTTORE	SLIDING SWITCH
4	473114 N	TRASFORMATORE 230V	230V TRANSFORMER
	473116 Q	TRASFORMATORE 115V	115 V TRANSFORMER
5	473031 N	CONTENITORE GRUPPO RETE	NETWORK UNIT COMPARTMENT
6	473030 Z	SCHERMO PER PIASTRA	BOARD SCREEN
7	473032 P	SCHERMO CONNETTORI	CONNECTOR SCREEN
8	474402 Z	CAVO PIASTRINO ALIMENTAZIONE	CABLE FOR POWER SUPPLY BOARD
9	759413 G	STAFFA FISSAGGIO MECCANICA	MECHANICAL FIXING ROD
10	470925 U	GOMMINO DI APPOGGIO	RUBBER REST
11	723349 K	STUD FISSAGGIO TRASFORMATORE	TRANSFORMER FASTENING STUD
12	723352 E	GOMMINO SOSPENSIONE TRASFORMATORE	RUBBER SUPPORT FOR TRANSFORMER
13	5183323 H	INTERRUTTORE RETE	NETWORK SWITCH
14	5358331 H	FUSIBILE 2A-115V-5x20	FUSE 2A-115V-5x20
	5373182 A	FUSIBILE 1,25A-220V-5x20	FUSE 1,25A-220V-5x20
15	471839 T	GRUPPO PRESA RETE	NETWORK SOCKET UNIT
16	474399 D	PIASTRINO ALIMENTATORE	POWER SUPPLY BOARD



**GRUPPO STRUTTURA INFERIORE  
LOWER SECTION**

**PR2/S10**

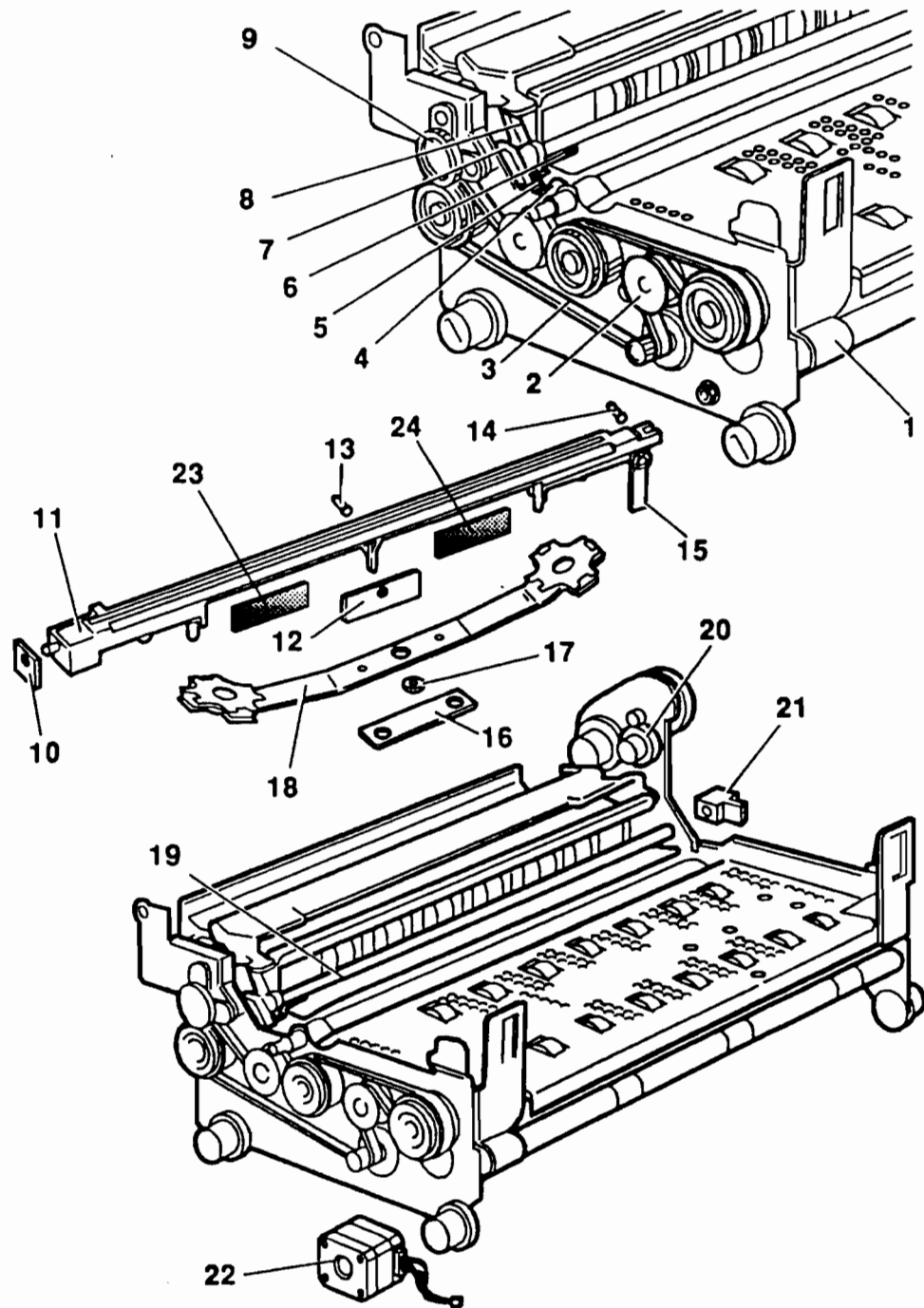
REF.	CODE	DESCRIZIONE	DESCRIPTION
1	473186 P	CONVOGLIATORE CARTA	PAPER FEED
2	473013 L	GOMMINO SMORZATORE STRUTTURA	DAMPING RUBBER FRAME
3	473069 C	GRUPPO MOTORE SERVIZI	MOTOR SERVICE UNIT
4	473018 Z	BOCCOLA SINISTRA	LEFT GUIDE BUSH
5	473006 W	GRUPPO FOTO POSTERIORE	REAR PHOTO UNIT
6	473028 T	GR. ALBERI DI TRASC. (Npz = 3)	FEED SHAFT GROUP (Pcs = 3)
7	473253 H	SPORTELLINO DEFLETTORE	DEFLECTOR FLAP
8	473073 Y	ALBERO SUPPORTO PRESSORI	PRESSURE SUPPORT ARM
9	473074 Z	PONTE COMANDO PRESSORI	LINK FOR PRESSURE MECH.
10	473072 X	CAMMA SERVIZI	SERVICE CAM
11	473075 S	PORTAMOLLA PRESSORI	PRESSURE SPRING HOLDER
12	473037 L	PENNELLO	BRUSH



**GRUPPO STRUTTURA INFERIORE  
LOWER SECTION**

**PR2/S10**

REF.	CODE	DESCRIZIONE	DESCRIPTION
1	473024 P	SCHERMO RULLINI	ROLLER SCREEN
2	473021 L	PULEGGIA TENDICINGHIA	BELT TENSION PULLEY
3	751171 D	CINGHIA TRASC. DOCUM. (Z=210)	DOCUMENT FEED BELT (Z=210)
4	473050 D	BILANCERE COMANDO BANDELLA	FLAP EQUALIZING DRIVE UNIT
5	473052 T	MOLLA GRUPPO BANDELLA	FLAP UNIT SPRING
6	473065 Y	MOLLA LEVA FOTOSENSORI	PHOTOELECTRIC LEVER SPRING
7	473051 S	MANOVELLA COMANDO BANDELLA	FLAP CONTROL MECHANISM
8	473053 U	LEVA FOTOSENSORI SERVIZI	PHOTOELECTRIC SERVICES LEVER
9	473174 S	GR. COMANDO RULLINI PRESSORI	CONTROLS FOR ROLLER PRESSURE
10	473049 G	ZAVORRA SINISTRA	LEFT BALLAST
11	473040 B	GR. TRAVERSA DI STAMPA	PRINTER CROSSFLIGHT UNIT
12	473058 H	ZAVORRA CENTRALE (Npz = 2)	CENTRAL BALLAST (Pcs = 2)
13	473056 X	PERNO PER ZAVORRA CENTRALE	CENTRAL BALLAST PIN
14	473047 W	PERNO PER ZAVORRA DESTRA	RIGHT BALLAST PIN
15	473048 F	ZAVORRA DESTRA	RIGHT BALLAST
16	473063 W	PIASTRINO FISSAGGIO BALESTRA	BALLAST ANCHORAGE PLATE
17	473064 X	RONDELLA PER BARRA	BAR WASHER
18	473059 A	GR. BALESTRA AMMORTIZZ.	SPRING DAMPER UNIT
19	473054 V	GR. BANDELLA PREMICARTA	PAPER PRESSURE FLAP
20	473071 W	INGRANAGGIO DI RINVIO	INTERMEDIATE GEAR
21	473057 Y	LEVA APERTURA BANDELLA	FLAP OPENING LEVER
22	473020 X	GRUPPO MOTORE INTERLINEA	LINE SPACING MOTOR UNIT
23	473066 Z	SILENZIATORE TRAVERSA STAMPA POST.	FRONT PRINTING BAR DAMPENING (10 x 70)
24	473067 S	SILENZIATORE TRAVERSA STAMPA ANT.	REAR PRINTING BAR DAMPENING (6 x 70)

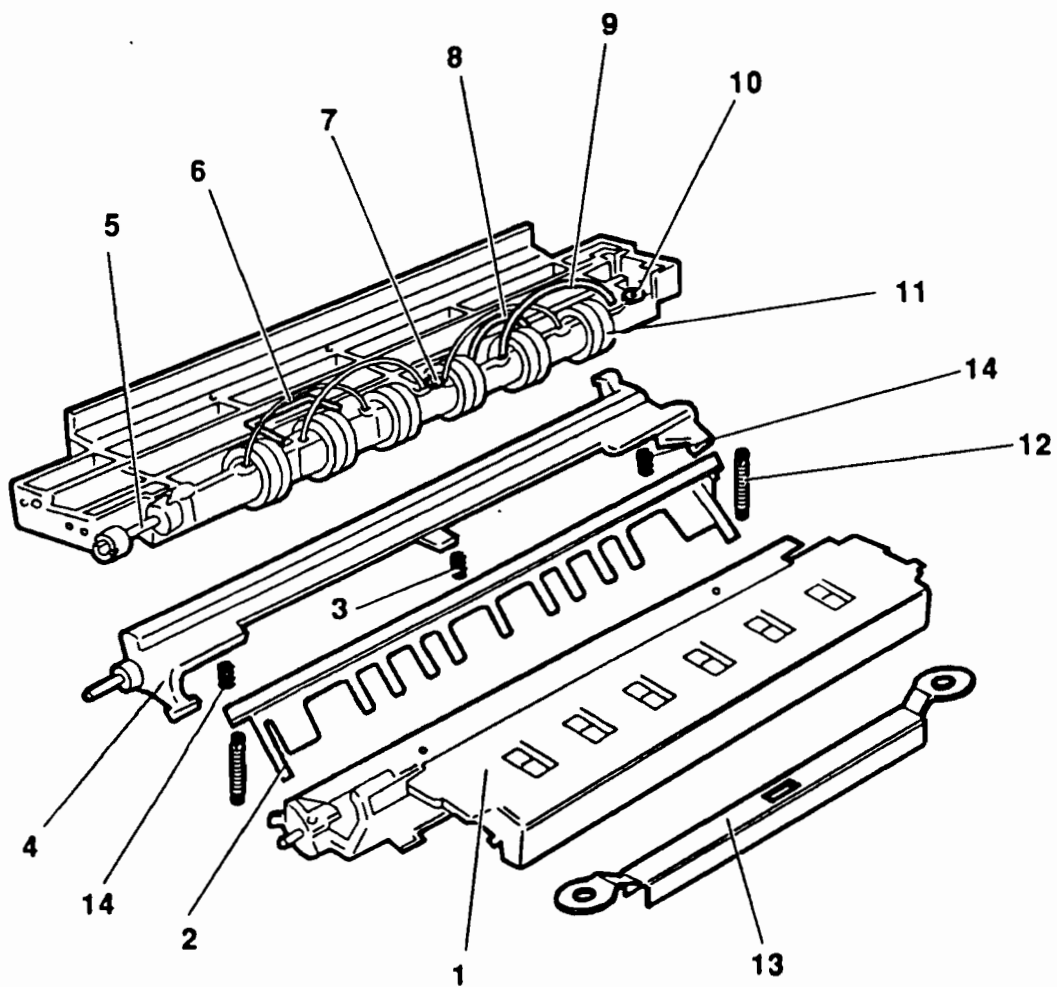


**GRUPPO STRUTTURA INFERIORE  
LOWER SECTION**

**PR2/S10  
PR2/S10**

REF.	CODE	DESCRIZIONE	DESCRIPTION
1	473085 M	SUPPORTO CARTA FOTO ANTERIORE	FRONT PHOTO SUPPORT
2	473077 U	PETTINE	COMB
3	473100 D	MOLLA PRESSORI CENTRALE	CENTRAL PRESSURE SPRING
4	473076 T	SUPPORTO PETTINE	SUPPORT FOR COMB
5	473175 T	GIUNTO	JOINT
6	473091 K	MOLLA RULLINI ALLINEAMENTO	ALIGNMENT ROLLER SPRING
7	473088 Y	BOCCOLA CENTRALE	CENTRAL GUIDE BUSH
8	473192 M	FIBRA OTTICA L=80	OPTICAL FIBER L=80
9	473191 L	FIBRA OTTICA L=100	OPTICAL FIBER L=100
10	473087 P	BOCCOLA LATERALE	SIDE GUIDE BUSH
11	473240 Q	GRUPPO RULLINI ALLINEAMENTO	ALIGNMENT ROLLERS UNIT
12	473078 D	MOLLA PETTINE (Npz = 2)	COMB SPRING (Pcs = 2)
13	473332 Y	TRAVERSA DI SUPPORTO FOTO	PHOTO SUPPORT BAR
14	473083 K	MOLLA PRESSORE LATERALE (Npz = 2)	SIDE PRESSURE SPRING (Pcs = 2)

473077 U  
 473100 D M → 8.68 in Val 3.99  
 473175 T → 12.12 in Val 3.99

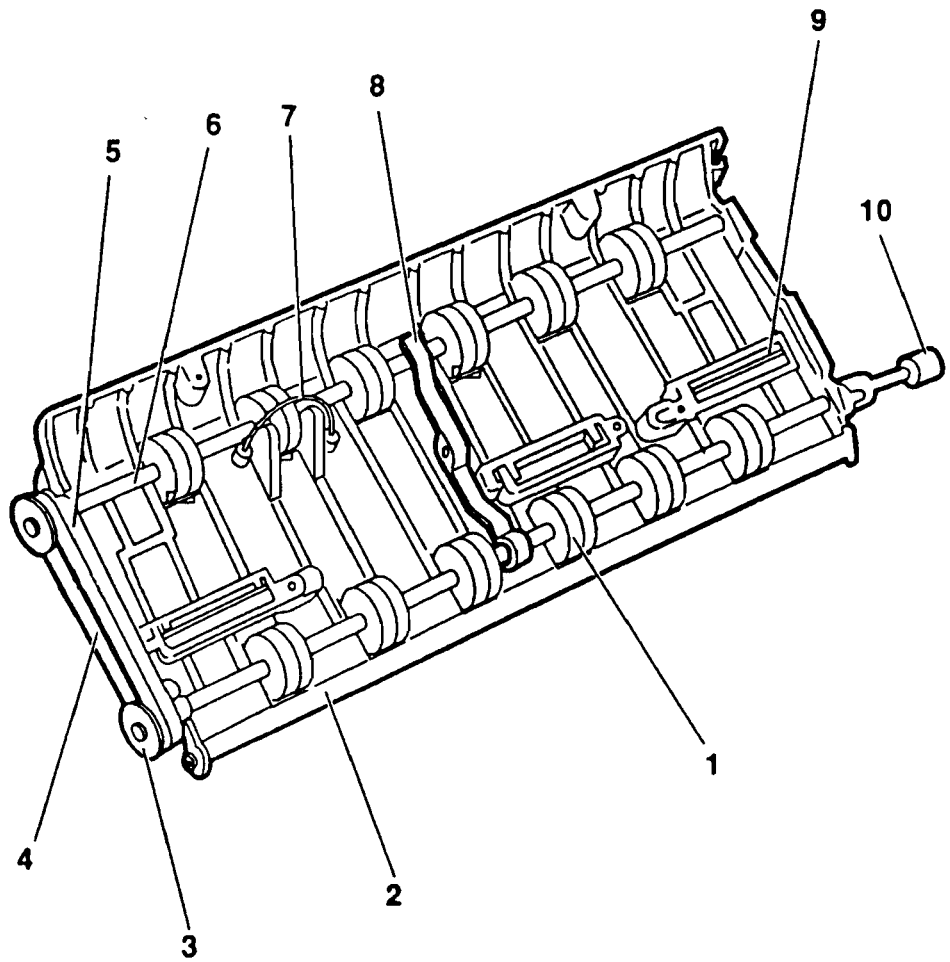




**GRUPPO PRESSORI POSTERIORI  
REAR PRESSURE UNIT**

**PR2/S10**

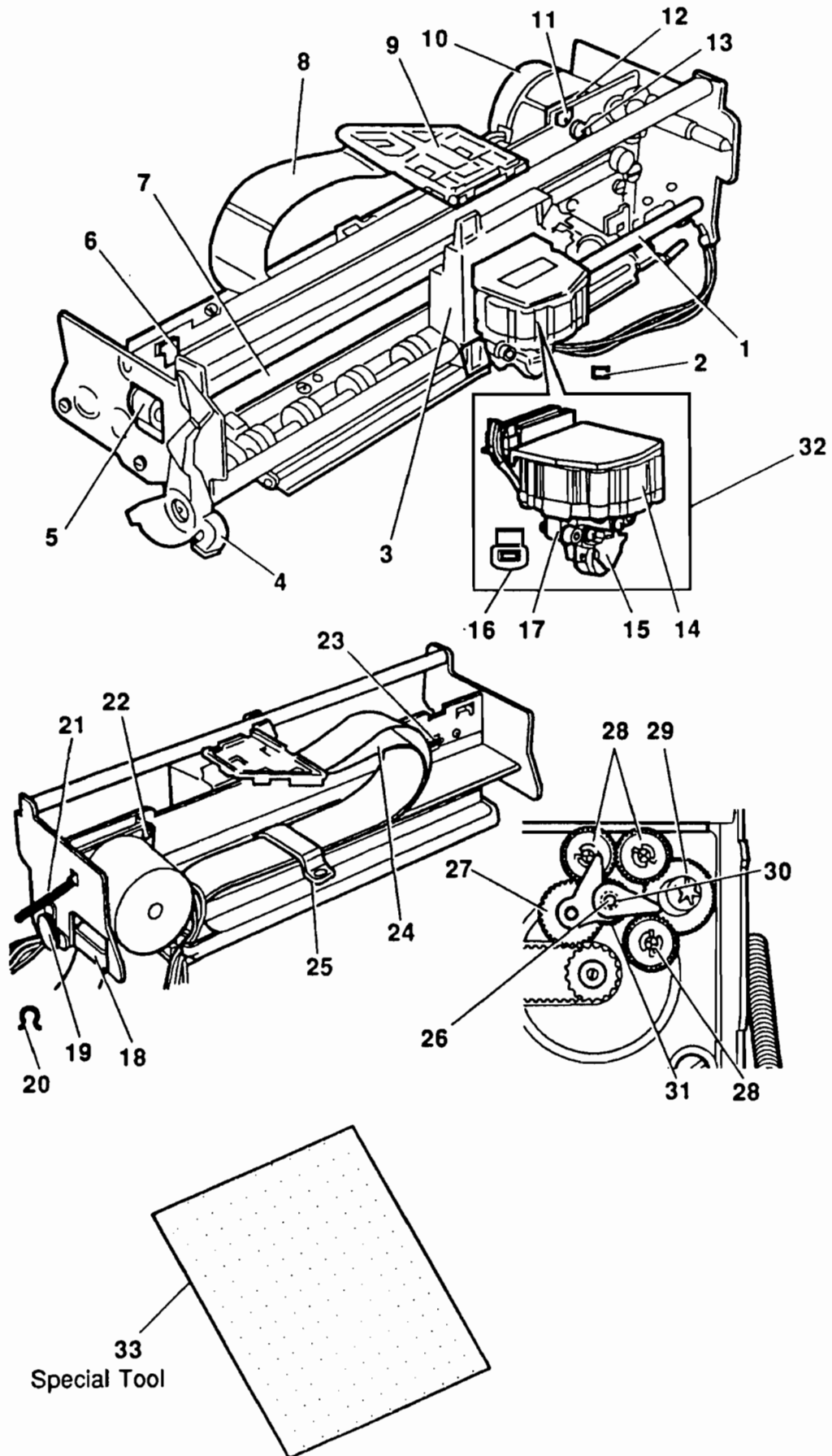
REF.	CODE	DESCRIZIONE	DESCRIPTION
1	473244 G	GRUPPO RULLINI ANTERIORI	FRONTS ROLLER UNIT
2	473160 G	SUPPORTO PRESSORI	PRESSURE UNITS SUPPORT
3	473166 S	PULEGGIA	PULLEY
4	473172 Y	CINGHIA DENTATA Z-88	COGGED BELT Z-88
5	473171 X	BOCCOLA SINISTRA	LEFT GUIDE BUSH
6	473248 L	GRUPPO RULLINI PRESSORI POSTERIORI	REAR PRESSURE ROLLERS UNIT
7	473192 M	FIBRA OTTICA L=80	OPTICAL FIBER L=80
8	473167 T	BOCCOLA CENTRALE	CENTRAL GUIDE BUSH
9	473173 Z	MOLLA TORSIONE ((Npz = 3)	TORSION SPRING (Pcs = 3)
10	473175 T	GIUNTO	JOINT



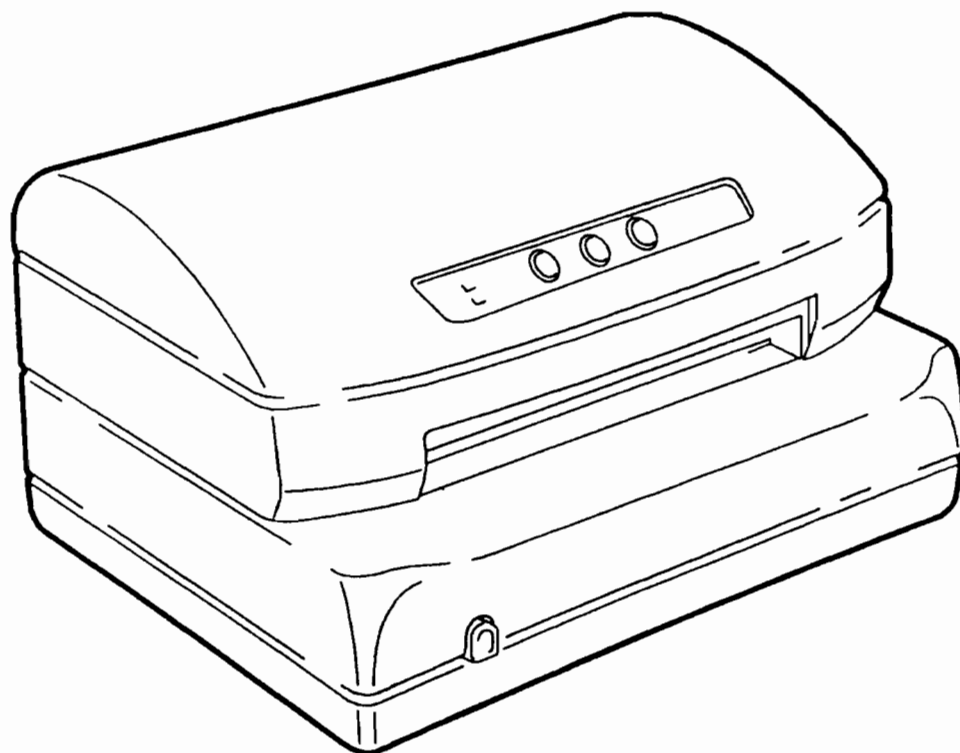
**GRUPPO STAMPA  
PRINTING UNIT**

PR2/S10

REF.	CODE	DESCRIZIONE	DESCRIPTION
1	473127 K	ALBERO SUPPORTO CARRELLO	CARRIAGE SUPPORT SHAFT
2	473150 E	FELTRO LUBRIFICAZIONE CARRELLO	CARRIAGE LUBRICATING PAD
3	473130 S	CARRELLO SUPPORTO TESTINA	HEAD SUPPORT CARRIAGE
X 4	473129 V	LEVA APERTURA STRUTTURA SUP.	OPENING LEVER FOR UPPER SEC. X
5	751272 J	PULEGGIA DI RINVIO	SNUB PULLEY
6	473149 H	SUPPORTO TENDICINGHIA	BELT TENSION SUPPORT
7	473123 P	CINGHIA TRASPORTO CARRELLO	CARRIAGE MOVEMENT BELT
8	473185 N	SCHERMO FLAT TESTINA	PRINT HEAD FLAT CABLE SCREEN
9	473137 M	SUPPORTO FLAT	SUPPORT FOR FLAT CABLE
10	473140 C	GRUPPO MOTORE TRASPORTO	TRANSPORT MOTOR UNIT
11	473156 Y	STAFFA COLLEG. TERRA	EARTH ROD
12	473141 Z	AMMORT. MOTORE TRASPORTO	TRANSPORT MOTOR DAMPER
13	471244 E	STUD PER FISSAGGIO MOTORE	MOTOR ANCHORAGE STUD
14	472281 V	TESTINA DI STAMPA 24 AGHI	24 NEED PRINT HEAD
15	473134 J	GRUPPO RULLINO TASTATURA	SENSOR HEAD ROLLER
16	473152 U	PROTEZIONE NASTRO	RIBBON PROTECTOR
17	473132 Q	GR. FOTOSENS. TASTATURA	SENSOR HEAD PHOTOELEC. UNIT
18	473139 X	STAFFA DX GUIDA FLAT	RIGHT FLAT CABLE GUIDE ROD
19	473180 V	GR. COMANDO RULLINI PRESS.	PRESSURE ROLLER DRIVE UNIT
20	473182 K	BALESTRINA PER GR. BOCCOLA	BUSH UNIT LEAF SPRING
21	473151 T	MOLLA PER LEVA DI BLOCC.	LOCKING LEVER SPRING
22	710769 X	PIASTRINO FISS. MOTORE TRASP.	TRANSP. MOTOR ANCHOR. PLATE
23	473155 X	MOLLA TENDICINGHIA	BELT TENSION SPRING
24	474400 B	FLAT TESTINA	PRINT HEAD FLAT CABLE
25	473138 W	STAFFA BLOCCAGGIO FLAT	FLAT CABLE ANCHORAGE ROD
26	473498 Y	SCAMBIATORE	EXCHANGER
27	473131 P	INGRANAGGIO COMANDO NASTRO	RIBBON DRIVE GEAR
28	753720 R	RUOTA TRASCIN. NASTRO	RIBBON FEED WHEEL
29	473147 X	LANCIA	LANCE
30	755144 E	MOLLA A COMPRESSIONE	COMPRESSION SPRING
31	473148 G	INGRANAGGIO COMANDO NASTRO	RIBBON DRIVE GEAR
32	473199 U	GR. TESTINA DI STAMPA	PRINT HEAD UNIT
33	473245 H	MYLAR TARATURA FOTOSENSORI	PHOTOSENSORS CALIBRATION MYLAR







**PR2/S12 - MACCHINA BASE +  
MAGNETICO ORIZZONTALE**

**PR2/S12 - STANDARD VERSION +  
HORIZONTAL MAGNETIC DEVICE**

**GRUPPO STRUTTURA INF. CON MAGNETICO ORIZZ.  
LOWER SECTION WITH HORIZ. MAGN. READER DEVICE**

**PR2/S12**

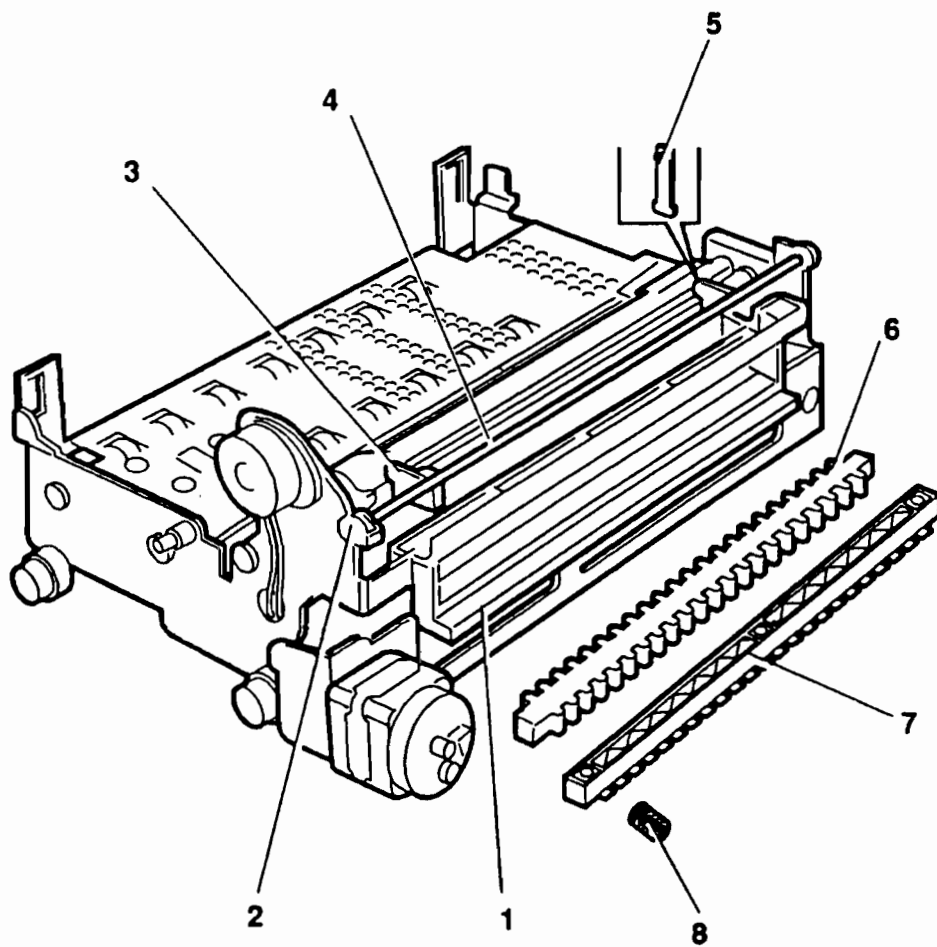
REF.	CODE	DESCRIZIONE	DESCRIPTION
1	473324 Y	CONVOGLIATORE CARTA PER MAGN. ORIZZ.	PAPER FEED FOR HOR.MAG. READER DEVICE
2	473315 X	MANOVELLA PER CAMMA	CAM LEVER
3	473317 Z	MANOVELLA PRESSORE	PRESSURE LEVER
4	473314 W	ALBERO SUPPORTO PRESSORE	PRESSURE SUPPORT ARM
5	473323 X	BIELLA PER MANOVELLA PRESSORE	PRESSURE LEVER ROD
6	473321 V	TAPPETO PER TRAVERSA PRESSORE	PRESSURE BAR PAD
7	473318 A	TRAVERSA PRESSORE	PRESSURE BAR
8	473320 G	MOLLA PRESSORE	PRESSURE SPRING

**NOTA:** Per le parti comuni fare riferimento alla PR2/S10 MACCHINA BASE descritta in precedenza.

**NOTE:** For parts common to the Standard version PR2/S10 please refer to the preceding section.

**GRUPPO STRUTTURA INF. CON MAGNETICO ORIZZ.  
LOWER SECTION WITH HORIZ. MAGN. READER DEVICE**

**PR2/S12**

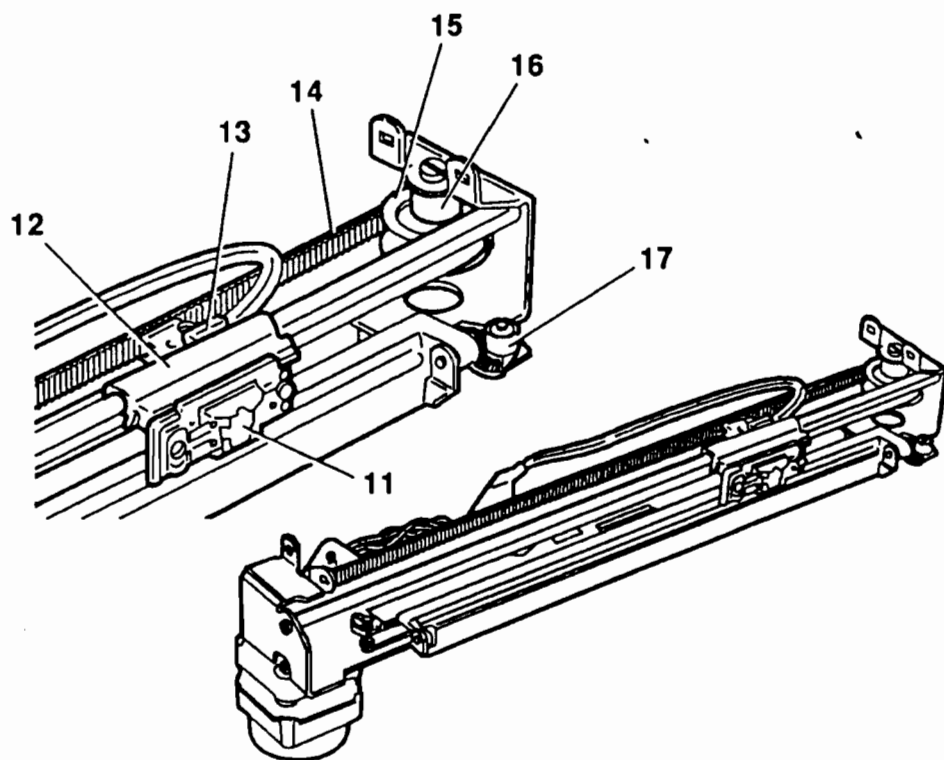
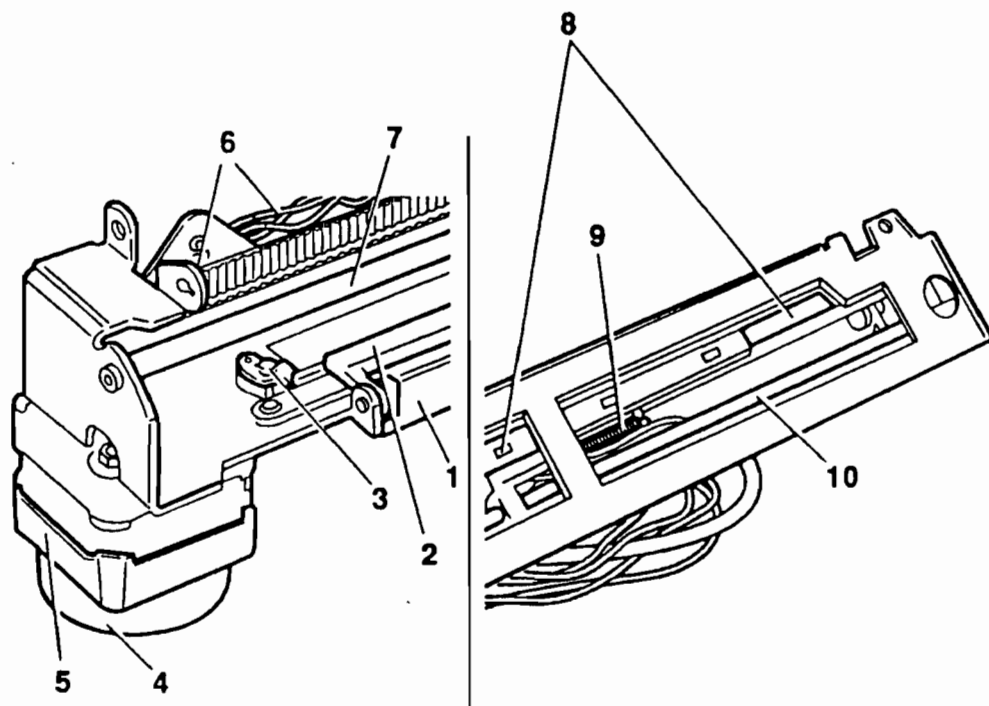


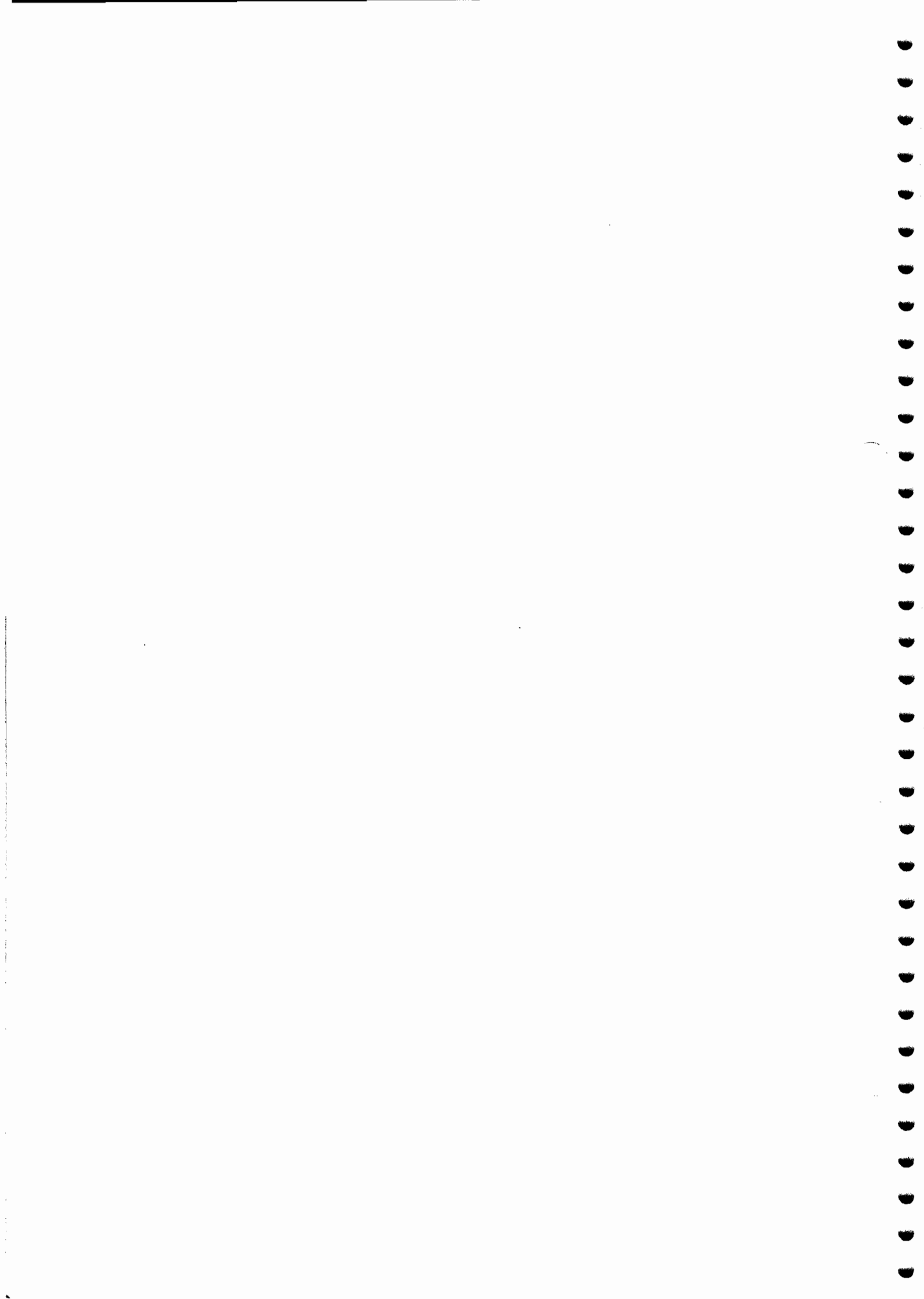


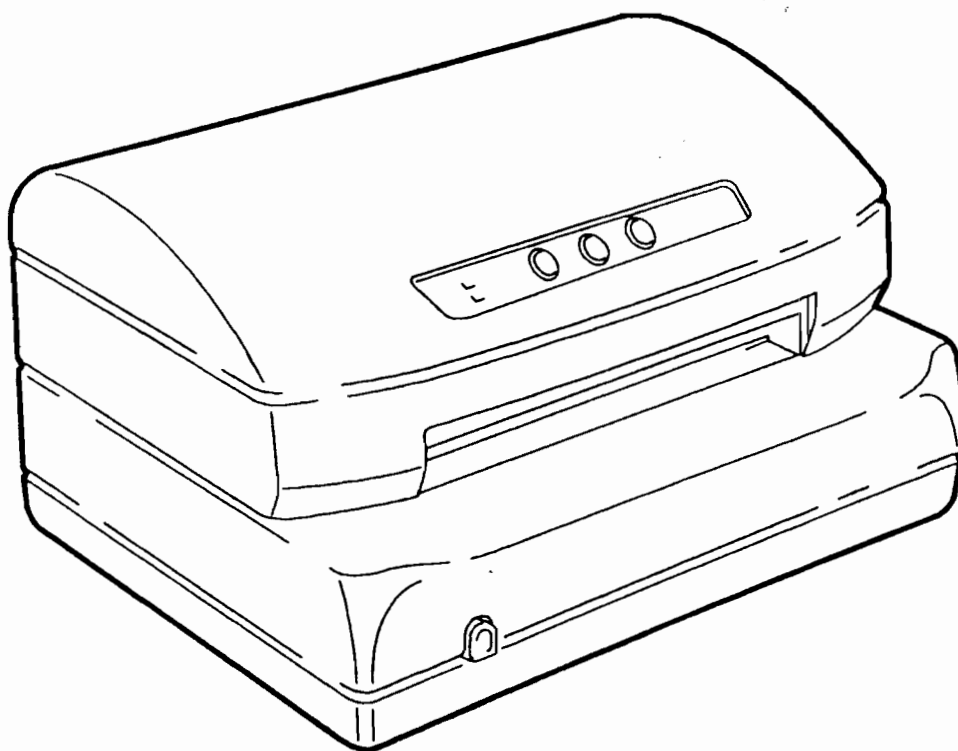
**GRUPPO MAGNETICO ORIZZONTALE  
HORIZONTAL MAGNETIC DEVICE**

**PR2/S12**

REF.	CODE	DESCRIZIONE	DESCRIPTION
1	473300 M	GR. STRUTTURA MAGN. ORIZZ.	HORIZ. MAG. READER DEVICE
2	473306 F	SPORTELLO DI CHIUSURA	COVER
3	473331 X	PONTE APERTURA SPORTELLO	FLAP OPENING JOINT
4	710682 H	SMORZATORE MOTORE TRASPORTO	TRANSPORT MOTOR DAMPER
5	473308 R	GRUPPO MOTORE TRASPORTO MAGN. ORIZZ.	HORIZ. MAG. TRANSPORT MOTOR UNIT
6	473330 A	GRUPPO FOTO AZZERAMENTO	PHOTO INITIALIZING UNIT
7	473312 U	BARRA GUIDA SUPERIORE (L=357)	UPPER TRACK (L=357)
8	473309 J	GRUPPO SEMITIRANTE	BRACE GROUP
9	471514 M	MOLLA CHIUSURA SPORTELLO	FLAP CLOSING SPRING
10	473313 V	BARRA GUIDA INFERIORE (L=327)	LOWER TRACK (L=327)
11	471530 Z	GRUPPO TESTINA MAGNETICA ORIZZ.	HORIZ. MAG. DEVICE HEAD UNIT
12	473310 E	CARRELLO TESTINA MAGNETICA	HEAD CARRIAGE
13	471501 Z	STAFFA BLOCCAGGIO TEST. MAGNETICA	LOCKING MAGNETIC HEAD UNIT
14	473311 T	CINGHIA MAGNETICO ORIZZ. (Z=360)	HORIZ. MAG. DEVICE BELT (Z=360)
15	473302 B	PULEGGIA DI RINVIO	SNUB PULLEY
16	473301 A	PERNO PER PULEGGIA	PULLEY PIN
17	473303 C	SETTORE DENTATO	SECTOR GEAR







**PR2/S13 - MACCHINA BASE + MAGNETICO  
VERTICALE**

**PR2/S13 - STANDARD VERSION + VERTICAL  
MAGNETIC DEVICE**

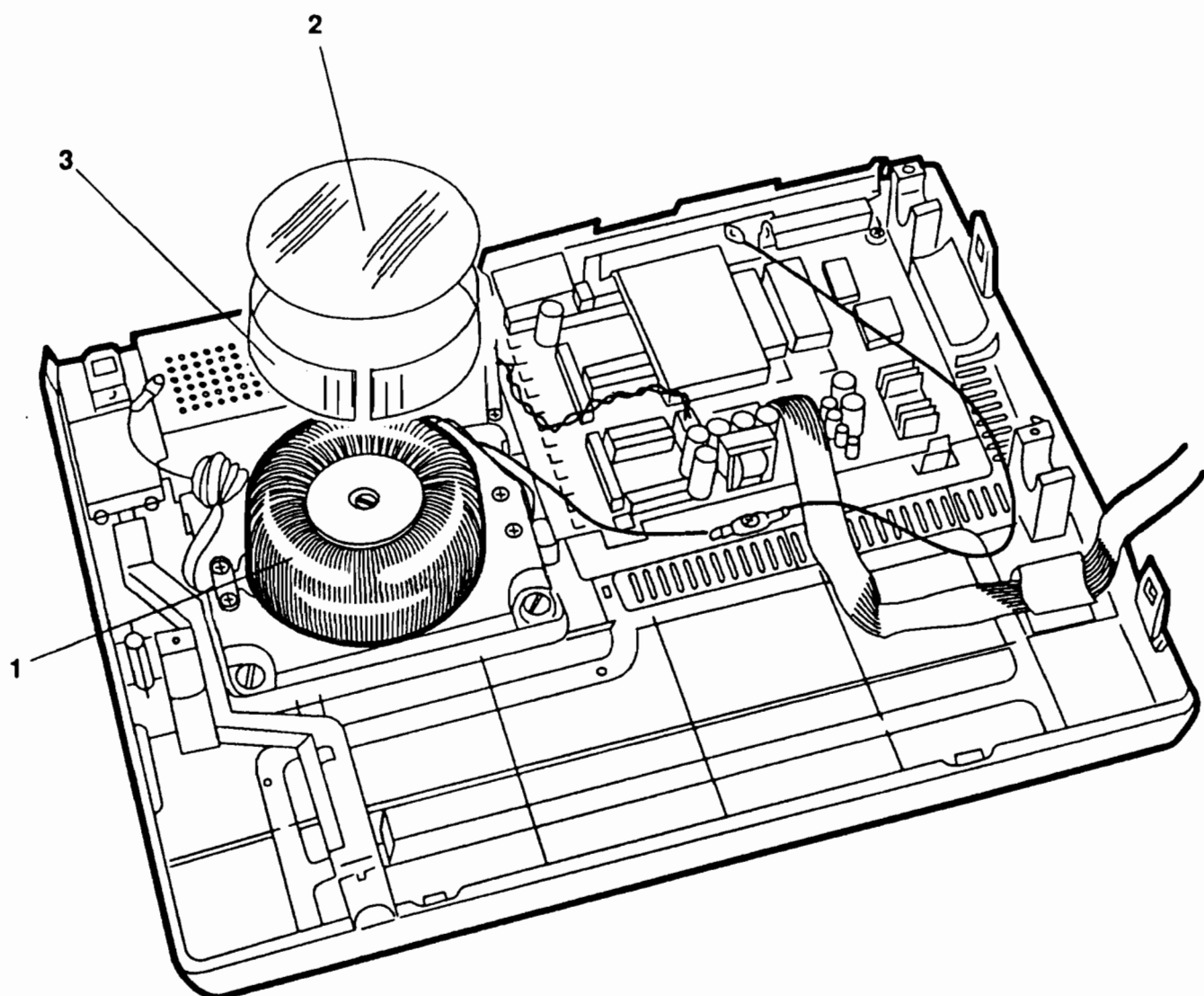
**GRUPPO FONDELLO E ALIMENTATORE CON M.V.  
UNIT BASE AND POWER SUPPLY FOR V.M.**

**PR2/S13**

REF.	CODE	DESCRIZIONE	DESCRIPTION
1	473114 N 473116 Q	GRUPPO TRASFORMATORE 230V GRUPPO TRASFORMATORE 110V	230V TRANSFORMER ASSEMBLY 110V TRANSFORMER ASSEMBLY
2	473493 K	MYLAR PROTEZ. SUPER. TRASF. M.V. SX	LEFT V. M. TRASF. UPPER PROTECT. MYLAR
3	473494 L	MYLAR PROTEZ. LATER. TRASF. M.V. SX	LEFT V. M. TRASF. SIDE PROTECT. MYLAR

**NOTA:** Per le parti comuni fare riferimento alla PR2/S10 MACCHINA BASE descritta in precedenza.

**NOTE:** For parts common to the Standard version PR2/S10 please refer to the preceding section.



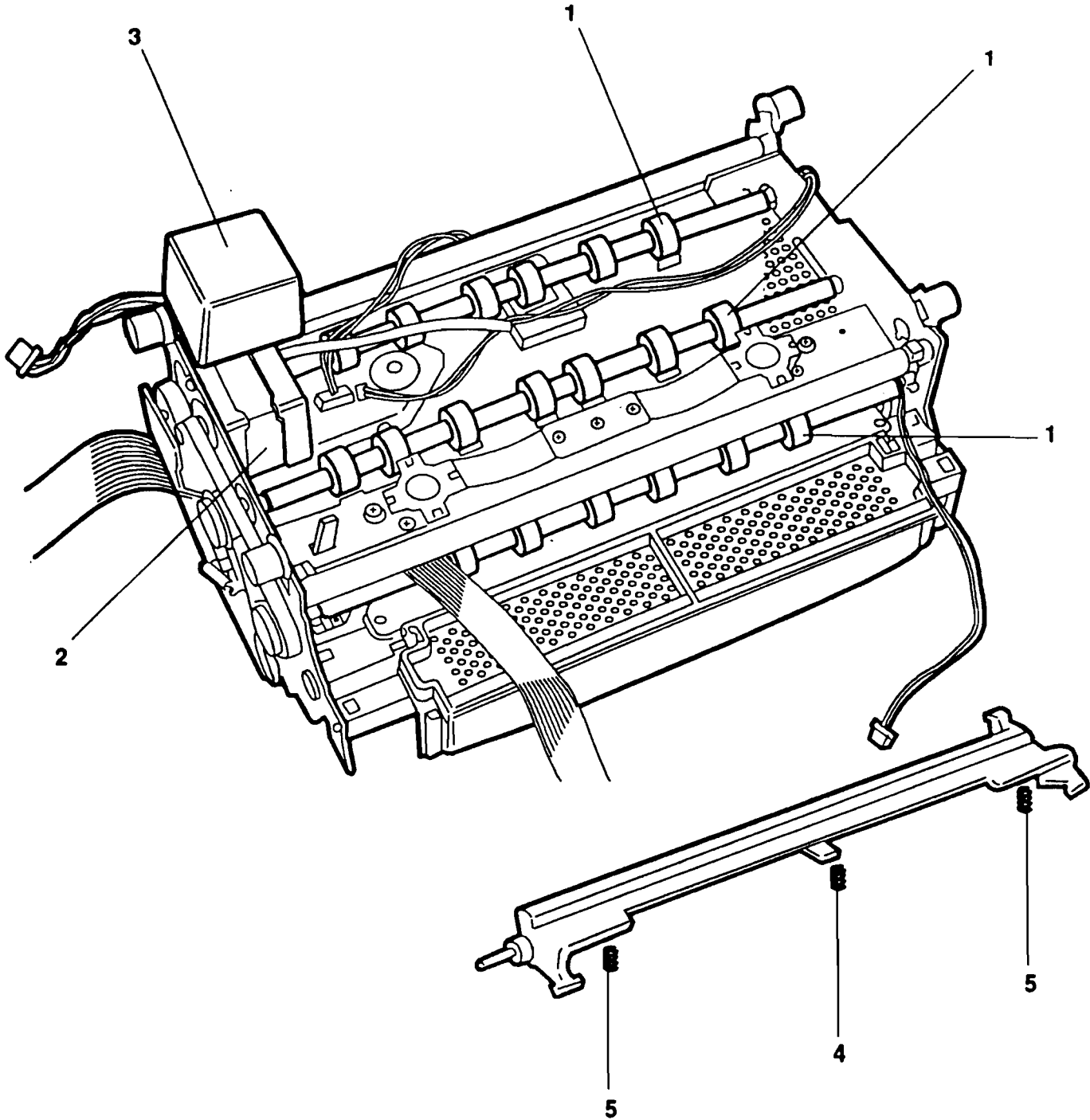
**GRUPPO STRUTTURA INFERIORE CON M.V.**  
**LOWER SECTION GROUP FOR V.M.**

**PR2/S13**

REF.	CODE	DESCRIZIONE	DESCRIPTION
1	473376 C 473396 Z	GR. ALBERI TRASCINAMENTO M.V. SX GR. ALBERI TRASCINAMENTO M.V. DX	LEFT VERTIC. MAGN. FEED SHAFT GROUP RIGHT VERTIC. MAGN. FEED SHAFT GROUP
2	473395 Y	MOTORE INTERLINEA MAGN. VERTIC.	VERTIC. MAGN. LINE SPACING MOTOR
3	473346 E	SCHERMO MOTORE MAGN. VERTIC. DX	RIGHT VERTIC. MAGN. MOTOR SHIELD
4	473083 K	MOLLA PRESSORE CENTRALE	CENTRAL PRESSURE SPRING
5	473100 D	MOLLA PRESSORE LATERALE (Npz = 2)	SIDE PRESSURE SPRING (Pcs = 2)

GRUPPO STRUTTURA INFERIORE CON M.V.  
LOWER SECTION GROUP FOR V.M.

PR2/S13

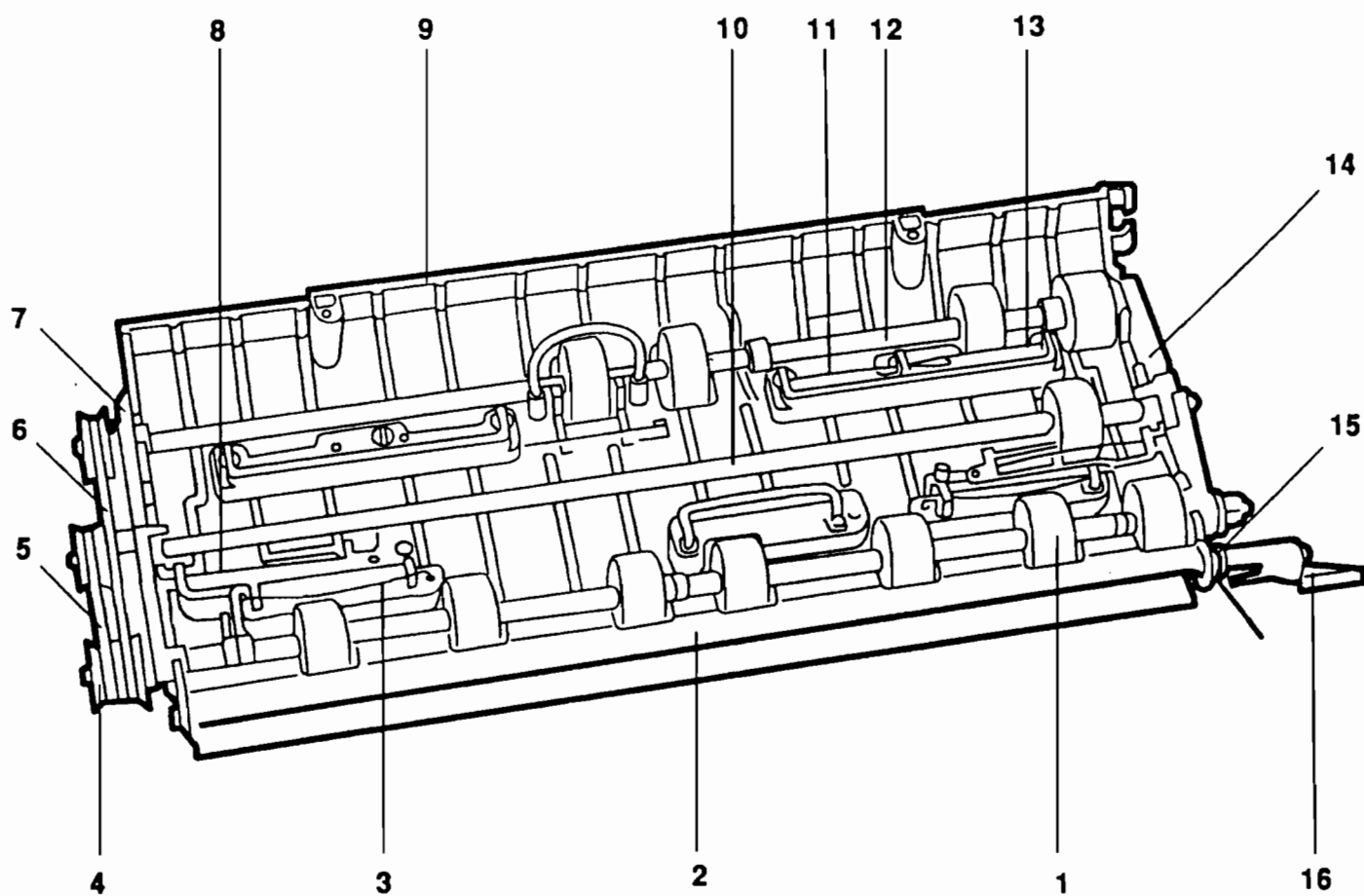




**GRUPPO PRESSORI POSTERIORI**  
**REAR PRESSURE UNIT**

**PR2/S13**

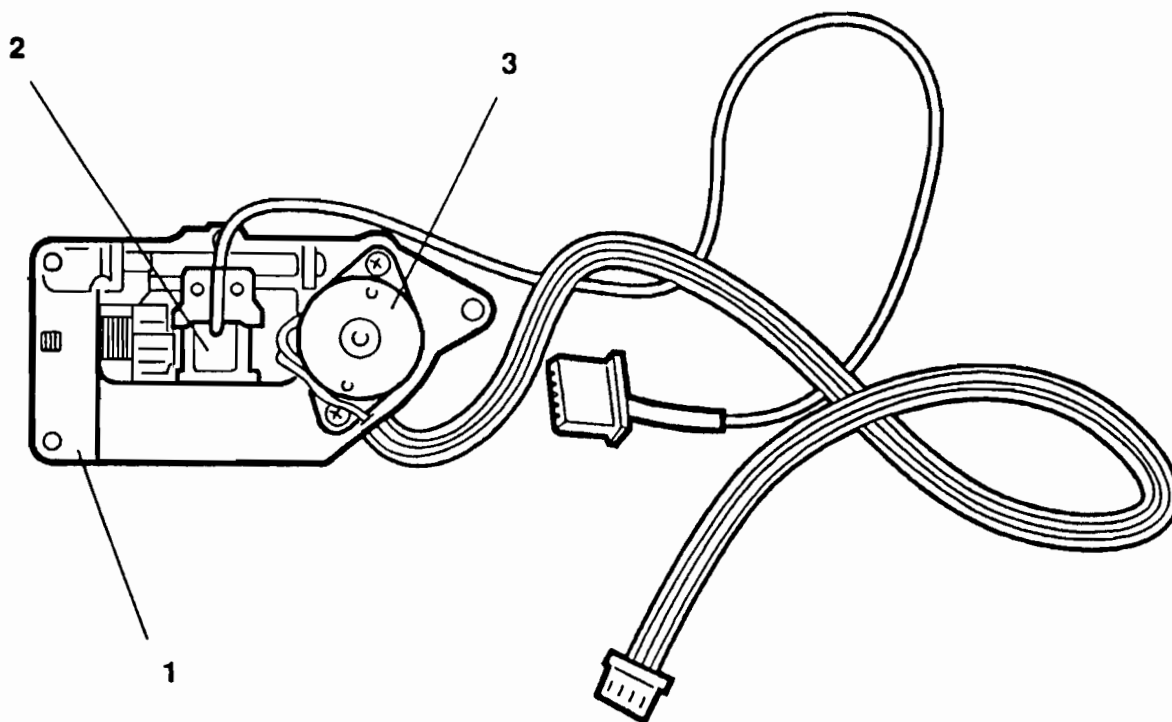
REF.	CODE	DESCRIZIONE	DESCRIPTION
1	473364 G 473383 U	GR. RULLINI ANTERIORI M.V. SX GR. RULLINI ANTERIORI M.V. DX	LEFT VERTIC. MAGN. FRONTS ROLLER UNIT RIGHT VERTIC. MAGN. FRONTS ROLLER UNIT
2	473390 F	GRUPPO MYLAR PER MAGN. VERTIC.	VERTIC. MAGN. MYLAR GROUP
3	473378 N	BARRA DI TORSIONE - VERDE (Npz = 2)	TORSION BAR - GREEN (Pcs = 2)
4	473370 J	PULEGGIA PER MAGN. VERTICALE	VERTIC. MAGN. PULLEY
5	473353 D	CINGHIA DENTATA Z=55	BELT TIMING Z=55
6	473348 Q	CINGHIA DENTATA Z=88	BELT TIMING Z=88
7	473355 F	SUPPORTO ALBERO	SHAFT SUPPORT
8	473298 F	BARRA DI TORSIONE - GIALLO (Npz = 2)	TORSION BAR - YELLOW (Pcs = 2)
9	473354 E 473382 T	SUPPORTO PRESSORI M.V. SX SUPPORTO PRESSORI M.V. DX	LEFT VERTIC. MAGN. PRESSURE SUPPORT RIGHT VERTIC. MAGN. PRESSURE SUPPORT
10	473372 G 473386 X	GRUPPO ALBERO CONTRASTO M.V. SX GRUPPO ALBERO CONTRASTO M.V. DX	LEFT VERT.MAGN. CONTRAST SHAFT GROUP RIGHT VERT.MAGN. CONTRAST SHAFT GROUP
11	473295 U	BARRA DI TORSIONE - ROSSO (Npz = 1)	TORSION BAR - RED (Pcs = 1)
12	473366 A 473385 W	GR. ALBERO POSTERIORE M.V. SX GR. ALBERO POSTERIORE M.V. DX	LEFT VERTIC. MAGN. REAR SHAFT GROUP RIGHT VERTIC. MAGN. REAR SHAFT GROUP
13	473296 V	BARRA DI TORSIONE - BLU (Npz = 1)	TORSION BAR - BLUE ((Pcs = 1)
14	473356 G	BOCCOLA PRESSORE M.V.	VERTIC. MAGN. PRESSURE BUSH
15	473394 X	MOLLA A SPILLO M.V.	VERTIC. MAGN. PIN SPRING
16	473393 W	MANOVELLA M.V.	VERTIC. MAGN. HANDLE

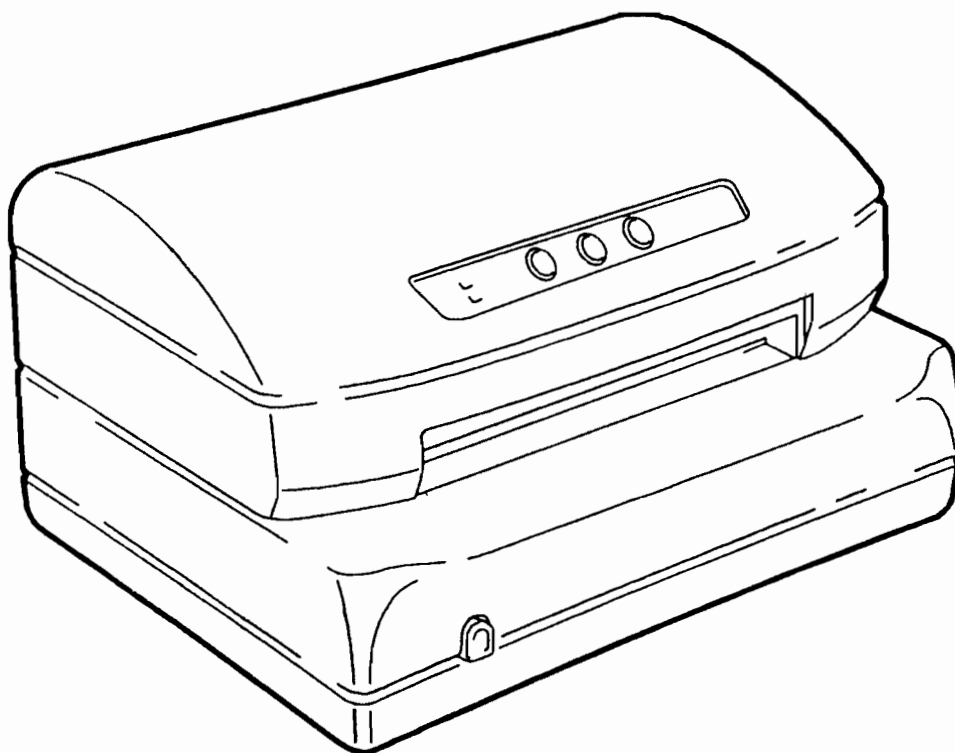


**GRUPPO MAGNETICO VERTICALE**  
**VERTICAL MAGNETIC DEVICE GROUP**

**PR2/S13**

REF.	CODE	DESCRIZIONE	DESCRIPTION
1	473297 W	GR. SUPPORTO MAGN. VERTIC.	VERTIC. MAG. SUPPORT GROUP
2	473351 B	GR. TESTINA MAGNETICA MAGN. VERTIC.	VERTIC. MAGN. DEVICE HEAD UNIT
3	473344 C	GRUPPO MOTORE MAGN. VERTIC.	VERTIC. MAGN. MOTOR UNIT





**PR2/S12 M - MACCHINA BASE +  
MAGNETICO ORIZZONTALE + MICR**

**PR2/S12 M - STANDARD VERSION +  
HORIZONTAL MAGNETIC DEVICE + MICR**

## GR. STRUTTURA INF. CON MAGNET. ORIZZ. E CON MICR

PR2/S12 M

## LOWER SECTION WITH HORIZ. MAGN. READER DEVICE WITH MICR

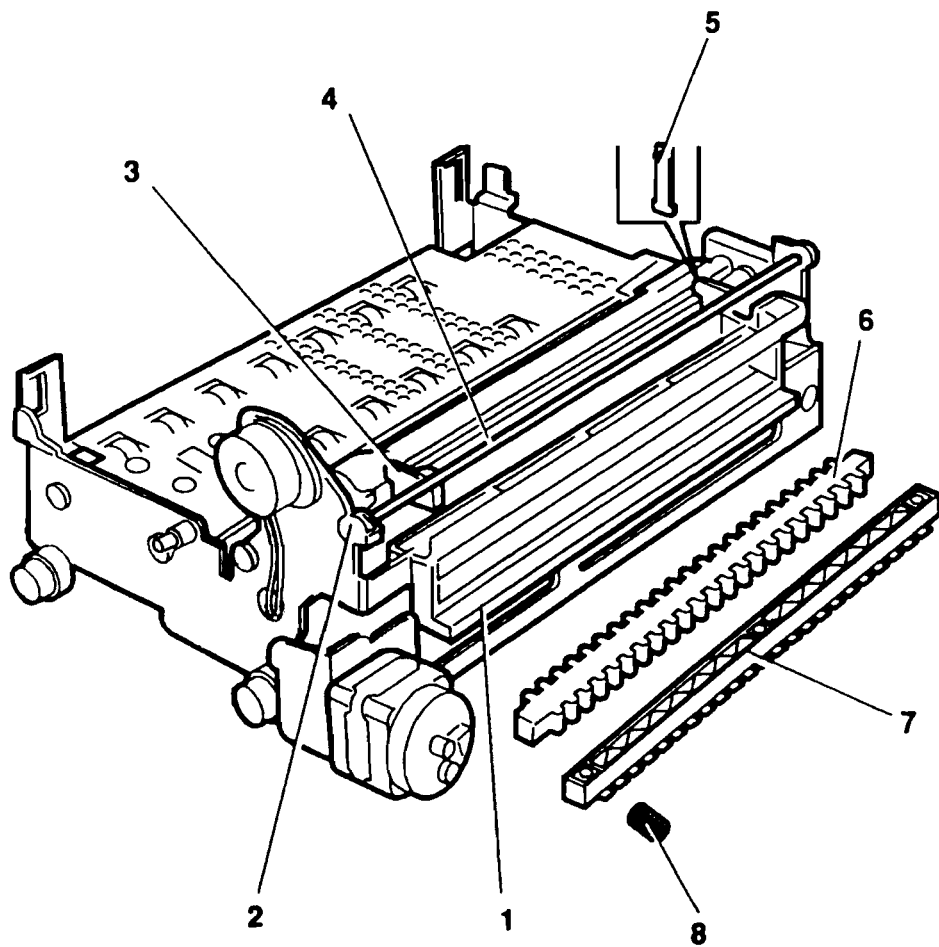
REF.	CODE	DESCRIZIONE	DESCRIPTION
1	473324 Y	CONVOGLIATORE CARTA PER MAGN. ORIZZ.	PAPER FEED FOR HOR.MAG. READER DEVICE
2	473315 X	MANOVELLA PER CAMMA	CAM LEVER
3	473317 Z	MANOVELLA PRESSORE	PRESSURE LEVER
4	473314 W	ALBERO SUPPORTO PRESSORE	PRESSURE SUPPORT ARM
5	473323 X	BIELLA PER MANOVELLA PRESSORE	PRESSURE LEVER ROD
6	473329 D	TAPPETO PER TRAVERSA PRESSORE	PRESSURE BAR PAD
7	473318 A	TRAVERSA PRESSORE	PRESSURE BAR
8	473320 G	MOLLA PRESSORE	PRESSURE SPRING

NOTA: Per le parti comuni fare riferimento alla PR2/S10 MACCHINA BASE descritta in precedenza.

NOTE: For parts common to the Standard version PR2/S10 please refer to the preceding section.

GR. STRUTTURA INF. CON MAGNET. ORIZZ. E CON MICR  
LOWER SECTION WITH HORIZ. MAGN. READER DEVICE WITH MICR

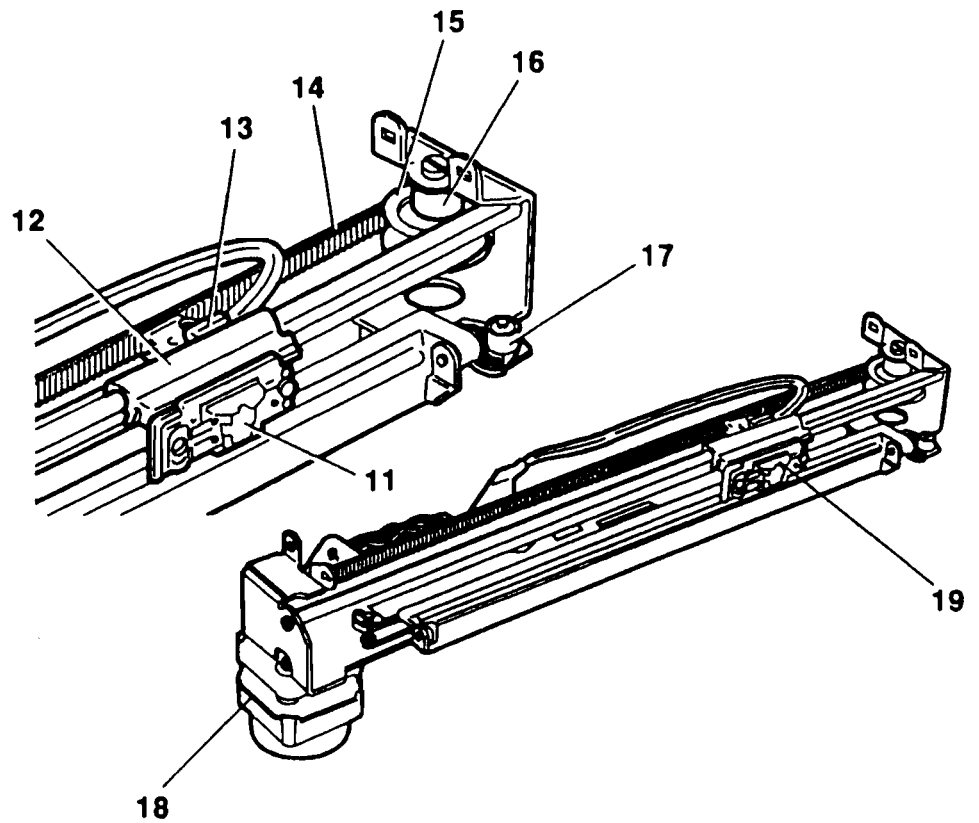
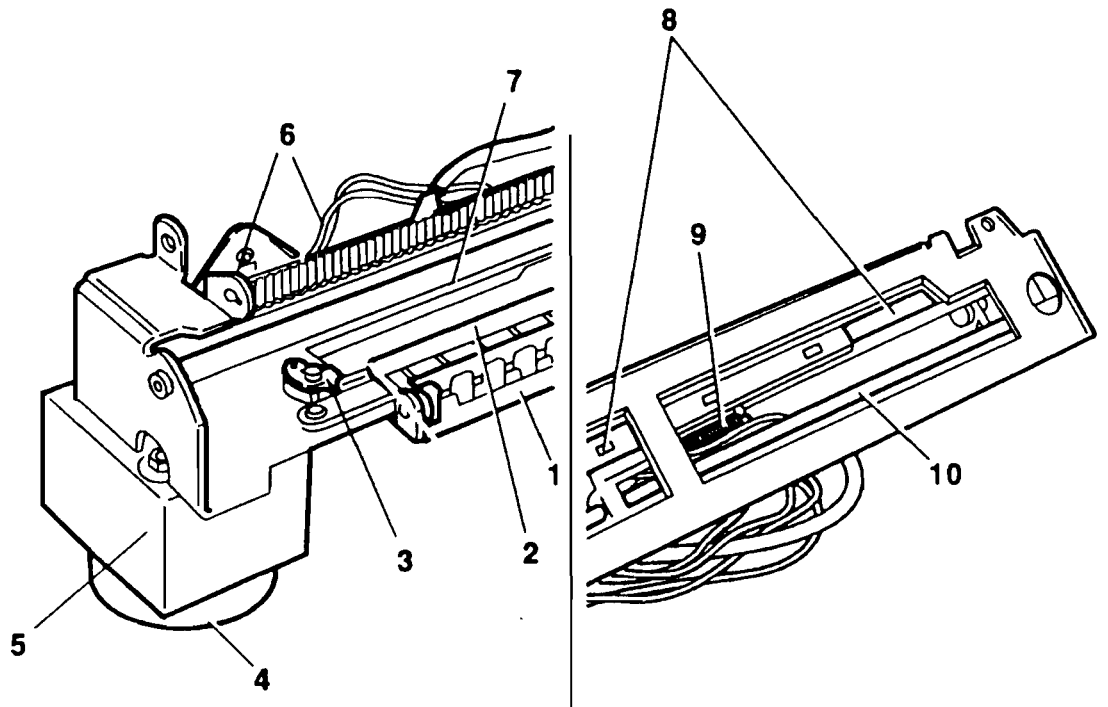
PR2/S12 M



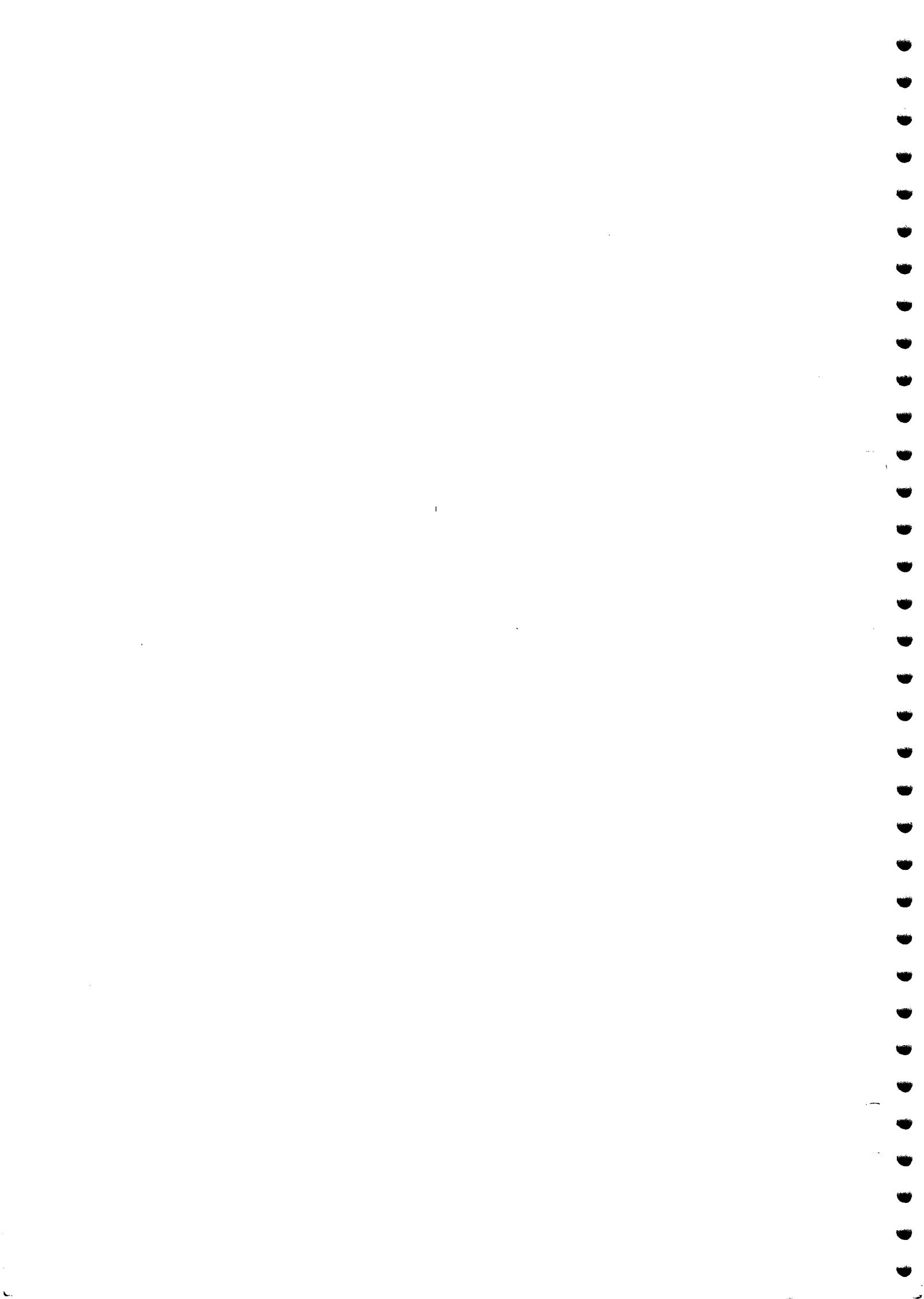
**GRUPPO MAGNETICO ORIZZONTALE  
HORIZONTAL MAGNETIC DEVICE**

**PR2/S12 M**

REF.	CODE	DESCRIZIONE	DESCRIPTION
1	473485 K	GR. STRUTTURA MAGN. ORIZZ. + MICR	HORIZ. MAG. READER DEVICE + MICR
2	473486 L	SPORTELLLO DI CHIUSURA	COVER
3	473331 X	PONTE APERTURA SPORTELLLO	FLAP OPENING JOINT
4	710682 H	SMORZATORE MOTORE TRASPORTO	TRANSPORT MOTOR DAMPER
5	473487 M	SCHERMO MOTORE MAGN. ORIZZ. / MICR	HORIZ. MAG. / MICR MOTOR SHIELD
6	473330 A	GRUPPO FOTO AZZERAMENTO	PHOTO INITIALIZING UNIT
7	473312 U	BARRA GUIDA SUPERIORE (L=357)	UPPER TRACK (L=357)
8	473309 J	GRUPPO SEMITIRANTE	BRACE GROUP
9	471514 M	MOLLA CHIUSURA SPORTELLLO	FLAP CLOSING SPRING
10	473313 V	BARRA GUIDA INFERIORE (L=327)	LOWER TRACK (L=327)
11	473480 S	GR. TESTINA MAGN. ORIZZ. + MICR	HORIZ. MAG. DEVICE + MICR HEAD UNIT
12	473310 E	CARRELLO TESTINA MAGNETICA	HEAD CARRIAGE
13	471501 Z	STAFFA BLOCCAGGIO TEST. MAGNETICA	LOCKING MAGNETIC HEAD UNIT
14	473311 T	CINGHIA MAGNETICO ORIZZ. (Z=360)	HORIZ. MAG. DEVICE BELT (Z=360)
15	473302 B	PULEGGIA DI RINVIO	SNUB PULLEY
16	473301 A	PERNO PER PULEGGIA	PULLEY PIN
17	473303 C	SETTORE DENTATO	SECTOR GEAR
18	473308 R	GR. MOTORE TRASP. MAGN. ORIZZ. + MICR	HORIZ. MAG. + MICR TRANSPORT MOTOR UNIT
19	473483 R	SCHERMO TESTINA MICR	MICR HEAD SHIELD







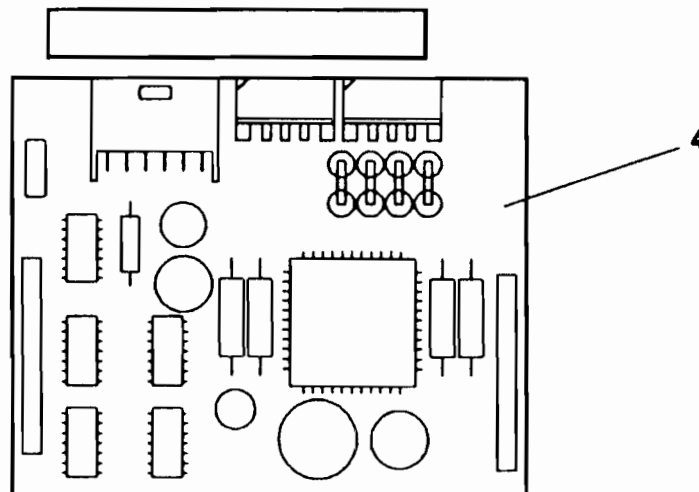
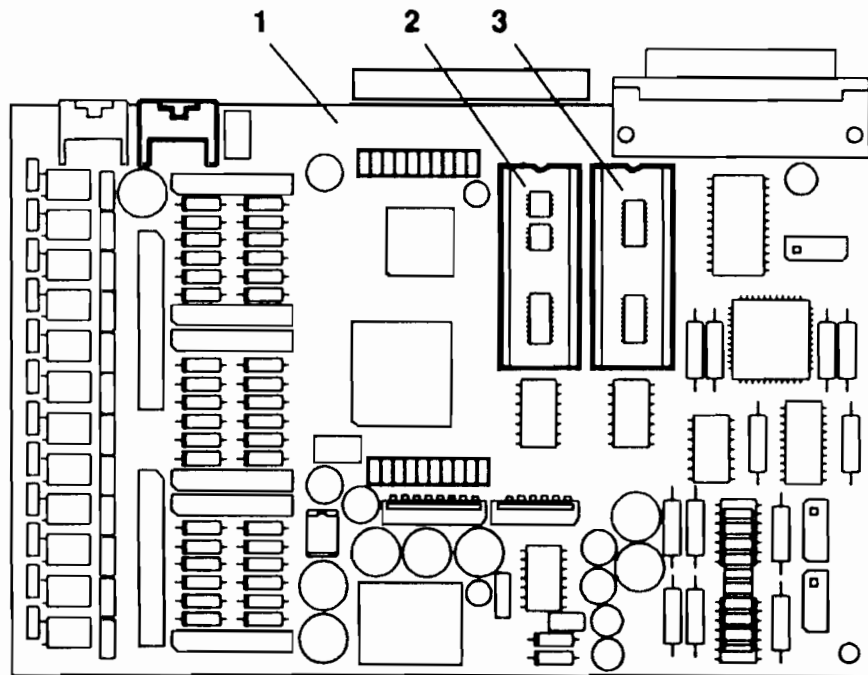
**PR2/S10-S12-S12M-S13 - PIASTRE ELETTRONICHE**

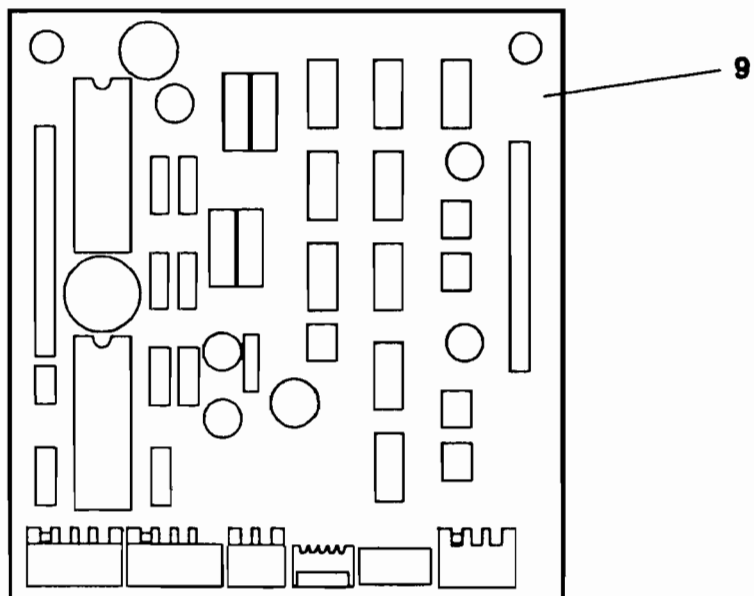
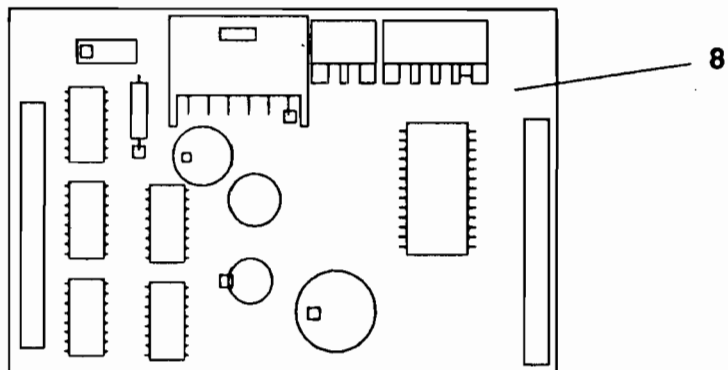
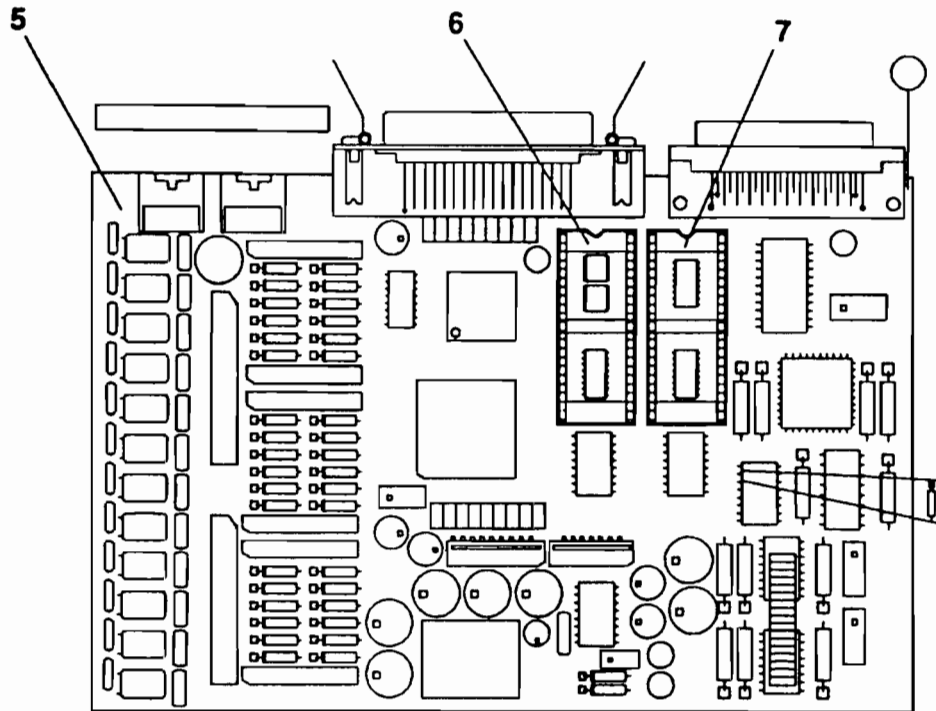
**PR2/S10-S12-S12M-S13 - ELECTRONIC BOARDS**

**PIASTRE ELETTRONICHE  
ELECTRONIC BOARDS**

**PR2/S10-S12-S12M-S13**

REF.	CODE	DESCRIZIONE	DESCRIPTION
1	612812 M	BAPR2STD - PIASTRA BASE SERIALE	SERIAL BASE BOARD BAPR2STD
2	474651 H 474537 P 475021 N	EPROM "PE 76" FIRMWARE STANDARD EPROM "PE 64" FIRMWARE DAECO FLASH EPROM PREINCISA	STANDARD EPROM FIRMWARE "PE 76" DAECO EPROM FIRMWARE "PE 64" PRE-RECORDED FLASH EPROM
3	474415 M 474417 P	EPROM "PE 56" GEN. CARATTERI STAND. EPROM "PE 58" GEN. CARATTERI DAECO	STANDARD EPROM "PE 56" GEN. CHARS. DAECO EPROM "PE 58" GEN. CHARS.
4	474552 W	PR2 MAGN. PIASTRINO MAGN.ORIZZ.	PR2 MAGN. BOARD HORIZ. MAGN. DEVICE
5	612811 L	BAPR2PS1 PIASTRA BASE SERIALE-PARALL.	BOARD SERIAL-PARALL. BAPR2PS1
6	474651 H 474537 P 475021 N	EPROM "PE 76" FIRMWARE STANDARD EPROM "PE 64" FIRMWARE DAECO FLASH EPROM PREINCISA	STANDARD EPROM FIRMWARE "PE 76" DAECO EPROM FIRMWARE "PE 64" PRE-RECORDED FLASH EPROM
7	474415 M 474417 P	EPROM "PE 56" GEN. CARATTERI STAND. EPROM "PE 58" GEN. CARATTERI DAECO	STANDARD EPROM "PE 56" GEN. CHARS. DAECO EPROM "PE 58" GEN. CHARS.
8	474396 S	PR2 VER. PIASTRINO MAGN.VERTIC.	PR2 VER. BOARD VERTIC. MAGN. DEVICE
9	474406 V	PIASTRINO MICR + MAGN.	BOARD MICR + MAG.





MINUTERIA  
DETAILS

PR2/S10-S12-S12M-S13

REF.	CODE	DESCRIZIONE	DESCRIPTION
1	750971 J	DADO M4 BLOCC. PONTE COM. PRESSORI	LINK FOR PRESSURE MECHANISM, M4 NUT
2	923032 A	VITE TRILOBATA M3x6	THREE LOBED SCREW M3x6
3	920617 S	VITE TESTA CILINDRICA M4x16	CHEESEHEAD SCREW M4X16
4	924710 T	VITE AUTOFORMANTE ø 2,2x6,5	THREAD-FOR. SCREW ø 2.2X6.5
5	924712 R	VITE AUTOFORMANTE ø 2,2x9,5	THREAD-FOR. SCREW ø 2.2X9.5
6	927005 L	VITE SCREWPLAST ø 2,9x6,5	SCREWPLAST SCREW ø 2.9X6.5
7	927006 M	VITE SCREWPLAST ø 2,9x9,5	SCREWPLAST SCREW ø 2.9X9.5
8	927013 B	VITE SCREWPLAST ø 2,9x13	SCREWPLAST SCREW ø 2.9X13
9	938220 E	DADO M3	M3 NUT
10	940098 A	RONDELLA ø 3,2x6	WASHER ø 3.2X6
11	940096 Y	RONDELLA ø 2,7x5	WASHER ø 2.7X5
12	940095 X	RONDELLA ø 2,2x5	WASHER ø 2.2X5
13	945230 F	STAFFA ø 2,3	ROD ø 2.3
14	945320 H	STAFFA ø 3,2	ROD ø 3.2
15	945500 F	STAFFA ø 5	ROD ø 5
16	926319 Z	STUD FILETTATO M3x4x1,5	STUD RIVET M3X4X1.5
17	664277 Q	VITE DI MASSA IN OTTONE M4	BRASS EARTH SCREW
18	920007 T	VITE TESTA CILINDRICA M2x8	CHEESEHEAD SCREW M2X8
19	921460 W	VITE TESTA CILINDRICA M3x8	CHEESEHEAD SCREW M3X8
20	920057 U	VITE TESTA CILINDRICA M46	CHEESEHEAD SCREW M46
21	921440 S	VITE TESTA CILINDRICA M2,5x4	CHEESEHEAD SCREW M2.5X4
22	473328 C	FASCETTA PER SMORZATORE	DAMPER CLAMP
23	723491 K	COLONNINA ESAGONALE M3X5	HEXAGONAL WHEEL BOX M3X5
24	966321 T	RONDELLA DENT. DIAM. 3,2X7	TOOTHED WASHER ø 3.2X7
25	945400 B	STAFFA DIAM. 4	ROD ø 4
26	920843 V	VITE TESTA ESAG. M3X6	HEX. HEADED SCREW M3X6
27	920864 S	VITE TESTA ESAG. CON INT. M4X6	HEX. HEADED SCREW M4X6
28	945700 P	STAFFA ø7	ROD ø 7

**INDICE GENERALE DEI CODICI**

**GENERAL CODES INDEX**

**INDICE GENERALE DEI CODICI  
GENERAL CODES INDEX**

**PR2/S10-S12-S12M-S13**

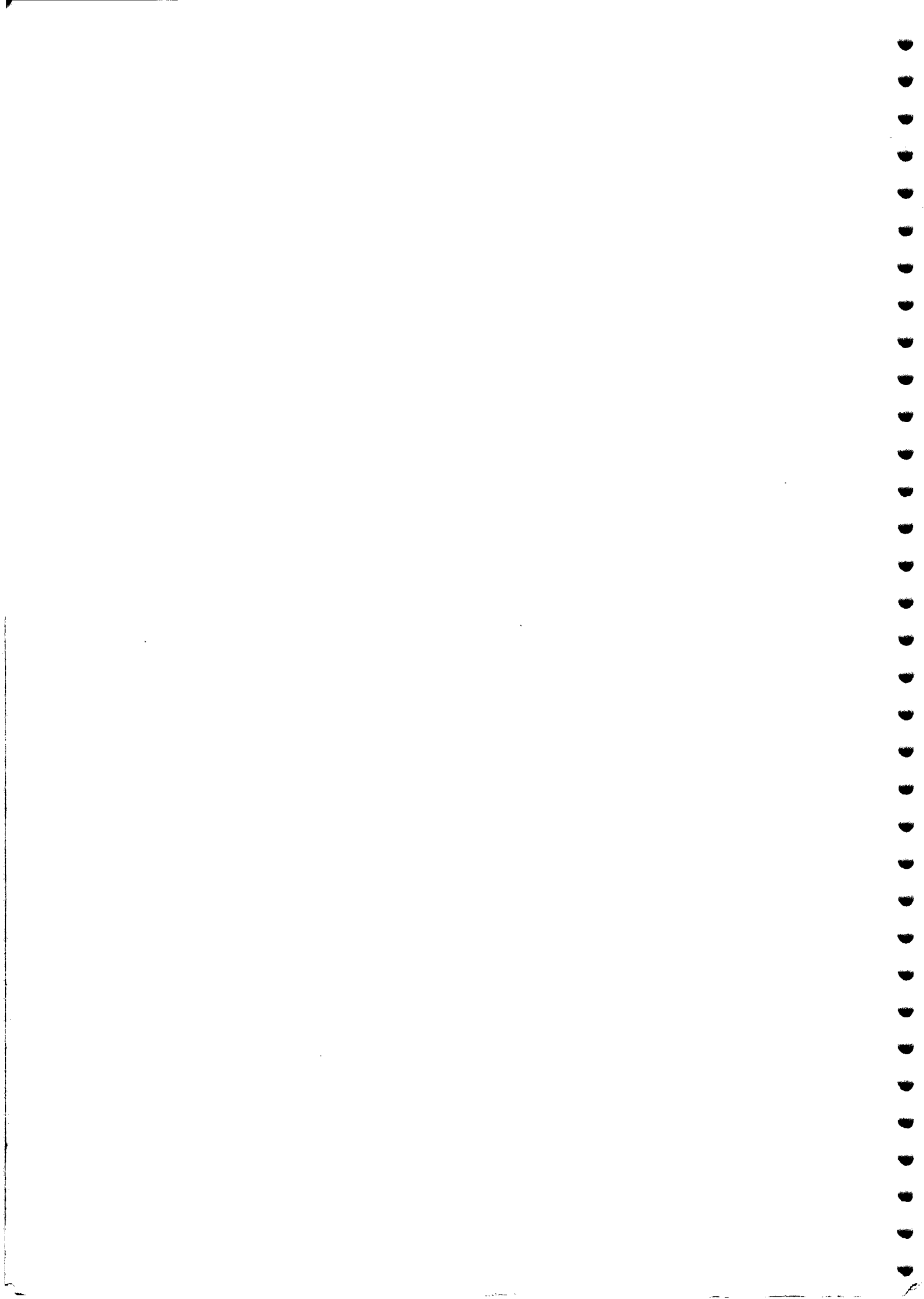
CODICE CODE	PAGINA PAGE	CODICE CODE	PAGINA PAGE	CODICE CODE	PAGINA PAGE
470925U	6	473114N	26	473308R	36
471244E	16	473116Q	6	473309J	22
471501Z	22	473116Q	26	473309J	36
471501Z	36	473123P	16	473310E	22
471514M	22	473127K	16	473310E	36
471514M	36	473129V	16	473311T	22
471530Z	22	473130S	16	473311T	36
471839T	6	473131P	16	473312U	22
472281V	16	473132Q	16	473312U	36
473006W	8	473134J	16	473313V	22
473013L	8	473137M	16	473313V	36
473018Z	8	473138W	16	473314W	20
473020X	10	473139X	16	473314W	34
473021L	10	473140C	16	473315X	20
473024P	10	473141Z	16	473315X	34
473028T	8	473147X	16	473317Z	20
473030Z	6	473148G	16	473317Z	34
473031N	6	473149H	16	473318A	20
473032P	6	473150E	16	473318A	34
473033Q	6	473151T	16	473320G	20
473034R	6	473152U	16	473320G	34
473037L	8	473155X	16	473321V	20
473040B	10	473156Y	16	473323X	20
473047W	10	473160G	14	473323X	34
473048F	10	473166S	14	473324Y	20
473049G	10	473167T	14	473324Y	34
473050D	10	473171X	14	473329D	34
473051S	10	473172Y	14	473328C	42
473052T	10	473173Z	14	473330A	22
473053U	10	473174S	10	473330A	36
473054V	10	473175T	12	473331X	22
473056X	10	473175T	14	473331X	36
473057Y	10	473180V	16	473332Y	12
473058H	10	473182K	16	473344C	32
473059A	10	473185N	16	473346E	28
473063W	10	473186P	8	473348Q	30
473064X	10	473191L	12	473351B	32
473065Y	10	473192M	12	473353D	30
473066Z	10	473192M	14	473354E	30
473067S	10	473199U	16	473355F	30
473069C	8	473240Q	12	473356G	30
473071W	10	473244G	14	473364G	30
473072X	8	473245H	16	473366A	30
473073Y	8	473248L	14	473370J	30
473074Z	8	473253H	8	473372G	30
473075S	8	473295U	30	473376C	28
473076T	12	473296V	30	473378N	30
473077U	12	473297W	32	473382T	30
473078D	12	473298F	30	473383U	30
473083K	12	473300M	22	473385W	30
473083K	28	473301A	22	473386X	30
473085M	12	473301A	36	473390F	30
473087P	12	473302B	22	473393W	30
473088Y	12	473302B	36	473394X	30
473091K	12	473303C	22	473395Y	28
473100D	12	473303C	36	473396Z	28
473100D	28	473306F	22	473480S	36
473114N	6	473308R	22	473483R	36

**INDICE GENERALE DEI CODICI  
GENERAL CODES INDEX**

**PR2/S10-S12-S12M-S13**

<b>CODICE CODE</b>	<b>PAGINA PAGE</b>	<b>CODICE CODE</b>	<b>PAGINA PAGE</b>	<b>CODICE CODE</b>	<b>PAGINA PAGE</b>
473485K	36	927006M	42		
473486L	36	927013B	42		
473487M	36	938220E	42		
473493K	26	940095X	42		
473494L	26	940096Y	42		
473498Y	16	940098A	42		
473506Y	4	945230F	42		
473539Y	4	945320H	42		
473540D	4	945400B	42		
474396S	40	945500F	42		
474399D	6	945700P	42		
474400B	16	966321T	42		
474402Z	6	5183323H	6		
474406V	40	5358331H	6		
474415M	40	5373182A	6		
474415M	40				
474417P	40				
474417P	40				
474468A	4				
474469B	4				
474471V	4				
474472W	6				
474537P	40				
474537P	40				
474552W	40				
474651H	40				
474651H	40				
475021N	40				
475021N	40				
612811L	40				
612812M	40				
664277Q	42				
710682H	22				
710682H	36				
710769X	16				
723349K	6				
723352E	6				
723491K	42				
750971J	42				
751171D	10				
751272J	16				
752610J	4				
753720R	16				
755144E	16				
759410R	4				
759413G	6				
920007T	42				
920057U	42				
920617S	42				
920843V	42				
920864S	42				
921440S	42				
921460W	42				
923032A	42				
924710T	42				
924712R	42				
926319Z	42				
927005L	42				





**STATO DI AGGIORNAMENTO  
UPDATING STATUS**

DATA DATE	PAGINE AGGIORNATE UPDATED PAGES	PAGINE PAGES	CODICE CODE
01/1996	1ª EDIZIONE - 1ª EDITION	37	2720970S-00
08/1996	2ª EDIZIONE - 2ª EDITION	42	2720971T-01
05/1997	3ª EDIZIONE - 3ª EDITION	47	2720972F-02

STAMPANTE - PRINTER

# PR 2

CATALOGO PARTI DI RICAMBIO  
SPARE PARTS CATALOGUE

**Code 687760Q-00**

---

## **IMPORTANTE**

PUBBLICAZIONE REDATTA DA OLIVETTI LEXIKON (GESTIONE RICAMBI E SCORTE).  
QUESTO CATALOGO È L' UNICO DOCUMENTO AL QUALE FARE RIFERIMENTO PER  
ORDINARE LE PARTI DI RICAMBIO.

## **IMPORTANT**

THIS PUBLICATION IS WRITTEN BY OLIVETTI LEXIKON (SPARE PARTS DEPARTMENT).  
THIS CATALOGUE IS THE ONLY DOCUMENT TO WHICH REFERENCE MAY BE MADE  
FOR ORDERING SPARE PARTS.

---

**PUBBLICAZIONE EMESSA DA:  
PUBLICATION ISSUED BY:**

**Olivetti Lexikon, S.p.A.**  
Documentazione  
77, Via Jervis - 10015 Ivrea (Italy)

*Copyright © 1999, by Olivetti  
All rights reserved*

*Printed in Italy by:*

**INDICE****PR2/S10 MACCHINA BASE**

COMPLESSIVO .....	Pag.3
CARROZZERIA .....	" 4
GRUPPO FONDELLO E ALIMENTATORE .....	" 6
GRUPPO STRUTTURA INFERIORE .....	" 8
GRUPPO PRESSORI POSTERIORI .....	" 14
GRUPPO STAMPA .....	" 16

**PR2/S12**

COMPLESSIVO .....	Pag. 19
GRUPPO STRUTTURA INFERIORE CON MAGN. ORIZZ. ....	" 20
GRUPPO MAGNETICO ORIZZONTALE .....	" 22

**PR2/S13**

COMPLESSIVO .....	Pag. 25
GRUPPO FONDELLO E ALIMENTATORE .....	" 26
GRUPPO STRUTTURA INFERIORE .....	" 28
GRUPPO PRESSORI POSTERIORI .....	" 30
GRUPPO MAGNETICO VERTICALE .....	" 32

**PR2/S12 M**

COMPLESSIVO .....	Pag. 33
GRUPPO STRUTTURA INFERIORE CON MAGN. ORIZZ. + MICR .....	" 34
GRUPPO MAGNETICO ORIZZONTALE + MICR .....	" 36

**PIASTRE ELETTRONICHE MOD. PR2/S10-PR2/S12-PR2/S12 M-PR2/S13**

PIASTRE ELETTRONICHE .....	Pag. 40
MINUTERIA .....	" 42

**PR2 SCANNER**

COMPLESSIVO .....	Pag. 43
CARROZZERIA .....	44
GRUPPO FONDELLO E ALIMENTATORE .....	" 46
GRUPPO STRUTTURA INFERIORE .....	" 48
GRUPPO PRESSORI POSTERIORI .....	" 54
GRUPPO SCANNER .....	" 56
GRUPPO MECCANICO SCANNER .....	" 57
GRUPPO STAMPA .....	" 58

<b>INDICE GENERALE DEI CODICI .....</b>	<b>Pag. 61</b>
---	----------------

**INDEX****STANDARD PR2/S10 VERSION**

OVERVIEW .....	Pag.	3
CASING .....	"	4
BASE UNIT AND POWER SUPPLY .....	"	6
LOWER SECTION GROUP .....	"	8
REAR PRESSURE UNIT .....	"	14
PRINTING UNIT .....	"	16

**PR2/S12**

OVERVIEW .....	Pag.	19
LOWER SECTION WITH HORIZ. MAGN. DEVICE .....	"	20
HORIZONTAL MAGNETIC READING DEVICE .....	"	22

**PR2/S13**

OVERVIEW .....	Pag.	25
BASE UNIT AND POWER SUPPLY .....	"	26
LOWER SECTION GROUP .....	"	28
REAR PRESSURE UNIT .....	"	30
VERTICAL MAGNETIC DEVICE GROUP .....	"	32

**PR2/S12 M**

OVERVIEW .....	Pag.	33
LOWER SECTION WITH HORIZ. MAGN. DEVICE .....	"	34
HORIZONTAL MAGNETIC READING DEVICE .....	"	36

**ELECTRONIC BOARD MOD. PR2/S10-PR2/S12-PR2/S12 M-PR2/S13**

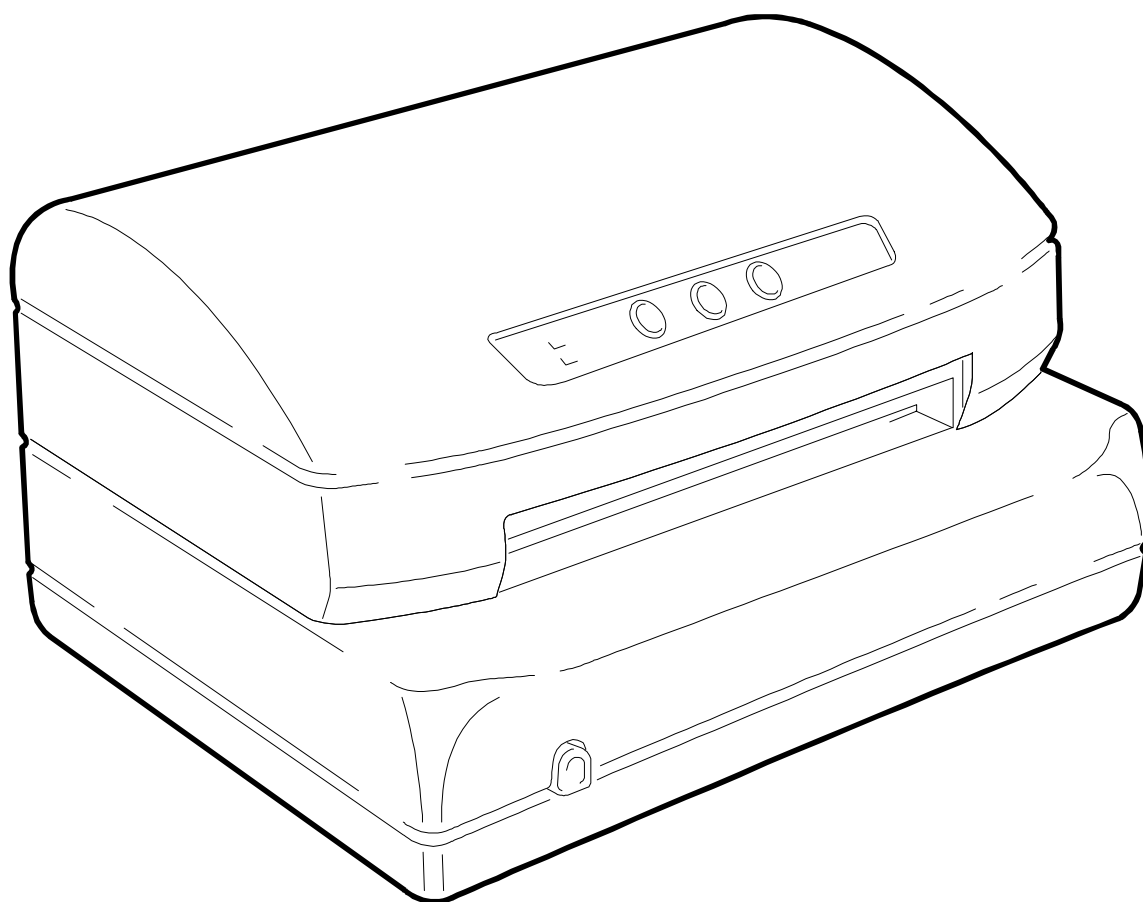
ELECTRONIC BOARD .....	Pag.	40
DETAILS .....	"	42

**STANDARD PR2/S10 VERSION**

OVERVIEW .....	Pag.	43
CASING .....	"	44
BASE UNIT AND POWER SUPPLY .....	"	46
LOWER SECTION GROUP .....	"	48
REAR PRESSURE UNIT .....	"	54
SCANNER UNIT .....	"	56
SCANNER MECHANICAL UNIT .....	"	57
PRINTING UNIT .....	"	58

<b>GENERAL INDEX.....</b>	<b>Pag.</b>	<b>61</b>
---------------------------	-------------	-----------

<b>MODELLO VERSION</b>	<b>DESCRIZIONE</b>	<b>DESCRIPTION</b>
PR2/S10 - D10	MODELLO BASE	STANDARD VERSION
PRS/S12 - D12	MODELLO BASE + MAGNETICO ORIZZONTALE	STANDARD VERSION + HORIZONTAL MAGNETIC DEVICE
PR2/S12M - D12M	MODELLO BASE + MAGNETICO ORIZZONTALE + MICR	STANDARD VERSION + HORIZONTAL MAGNETIC DEVICE + MICR
PR2/S13 - D13	MODELLO BASE + MAGNETICO VERTICALE	STANDARD VERSION + VERTICAL MAGNETIC DEVICE
PR2/SC	MODELLO BASE + SCANNER	STANDARD VERSION + SCANNER



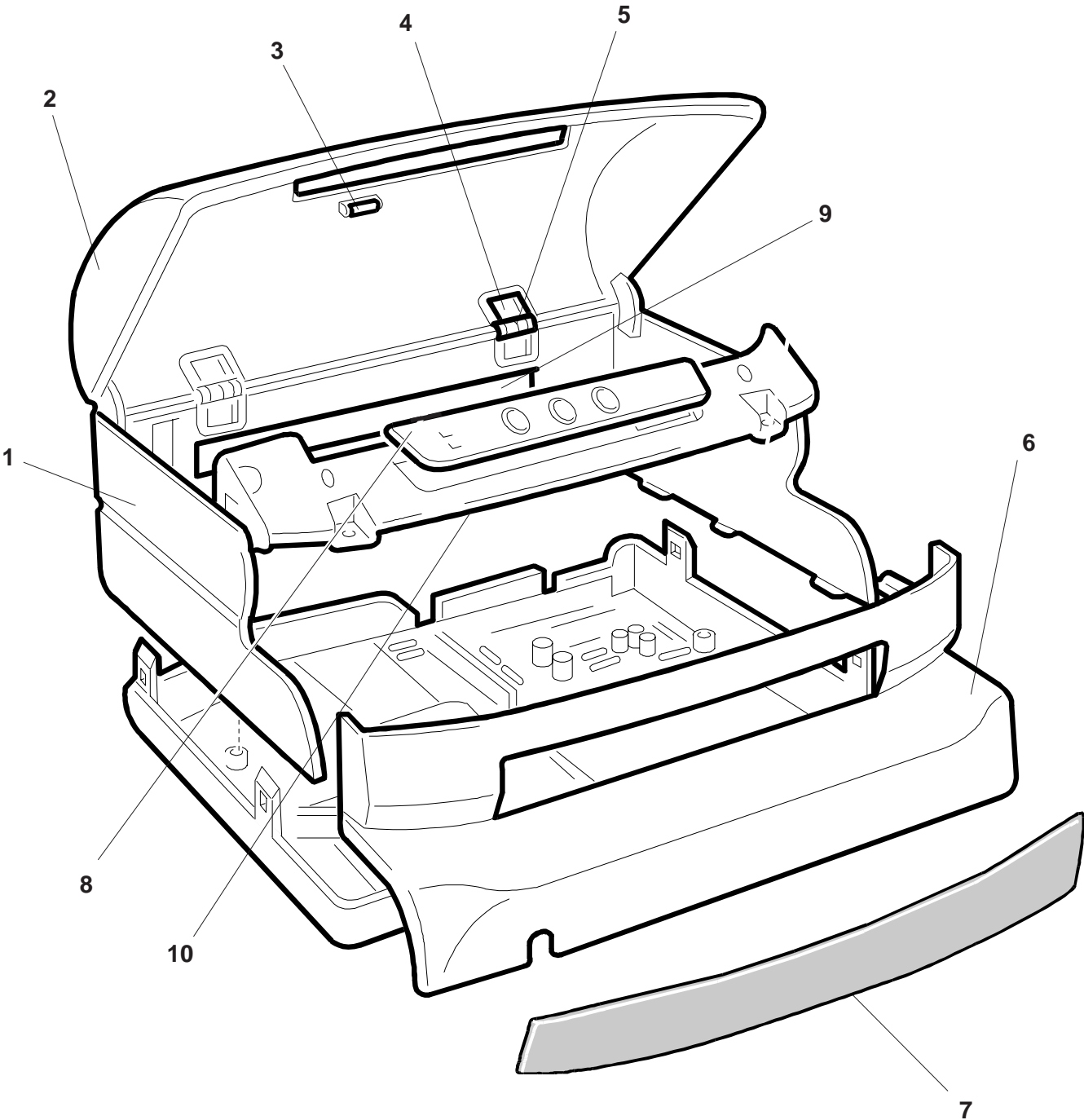
**PR2/S10 - PR2/D10 - MACCHINA BASE**

**PR2/S10 - PR2/D10 - STANDARD VERSION**

**CARROZZERIA  
CASING****PR2/S10**

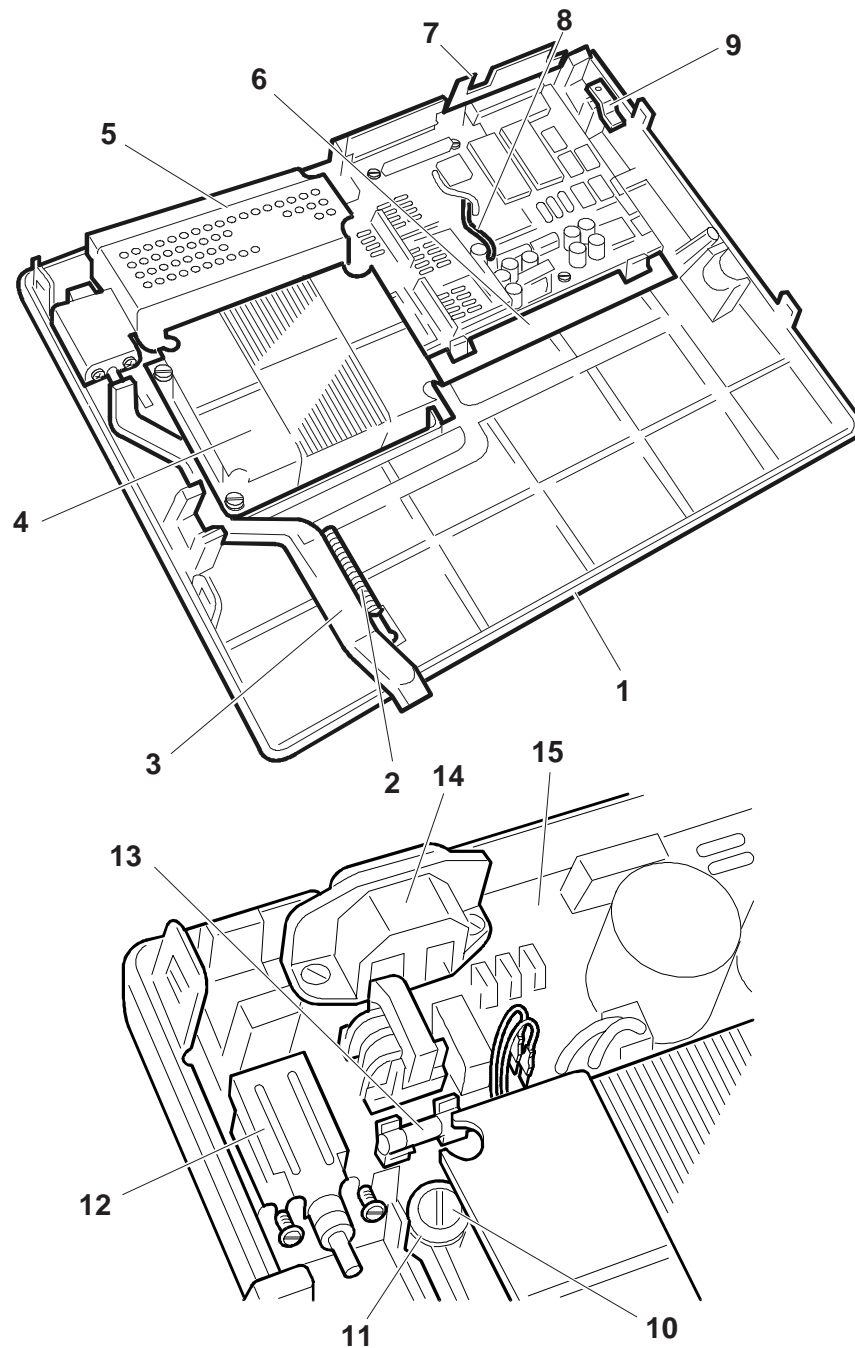
REF.	CODE	DESCRIZIONE	DESCRIPTION
1	474468 A	GRUPPO SCOCCA	BODY ASSEMBLY
2	474469 B 474463 V	GRUPPO COPERTURA SUPERIORE COPERTURA PIANO PER HALIFAX	UPPER COVER ASSEMBLY COVER FOR HALIFAX
3	752610 J	MAGNETE PER COPERTURA	COVER MAGNET
4	473540 D	CERNIERA	HINGE
5	759410 R	PERNO PER CERNIERA	HINGE FOR PIN
6	474471 V	GRUPPO FRONTALE	FRONT SECTION ASSEMBLY
7	473506 Y 473503 V	FONOASSORBENTE ANTERIORE FONOASSORB. ANT. PER MAGN. ORIZZ.	FRONT DEADENING FRONT DEADENING FOR ORIZONTAL MAGN.
8	475354 G	CONSOLE	CONSOLE
9	474475 Z	RIPARO POSTERIORE	REAR PROTECTION
10	473501 T 473472 V	INSONORIZZANTE VANO TESTINA (M.B.) INSONORIZZANTE VANO TESTINA (M.O.)	SOUND ABSORBENT FOR HEAD SPACE (M.B.) SOUND ABSORBENT FOR HEAD SPACE (M.O.)





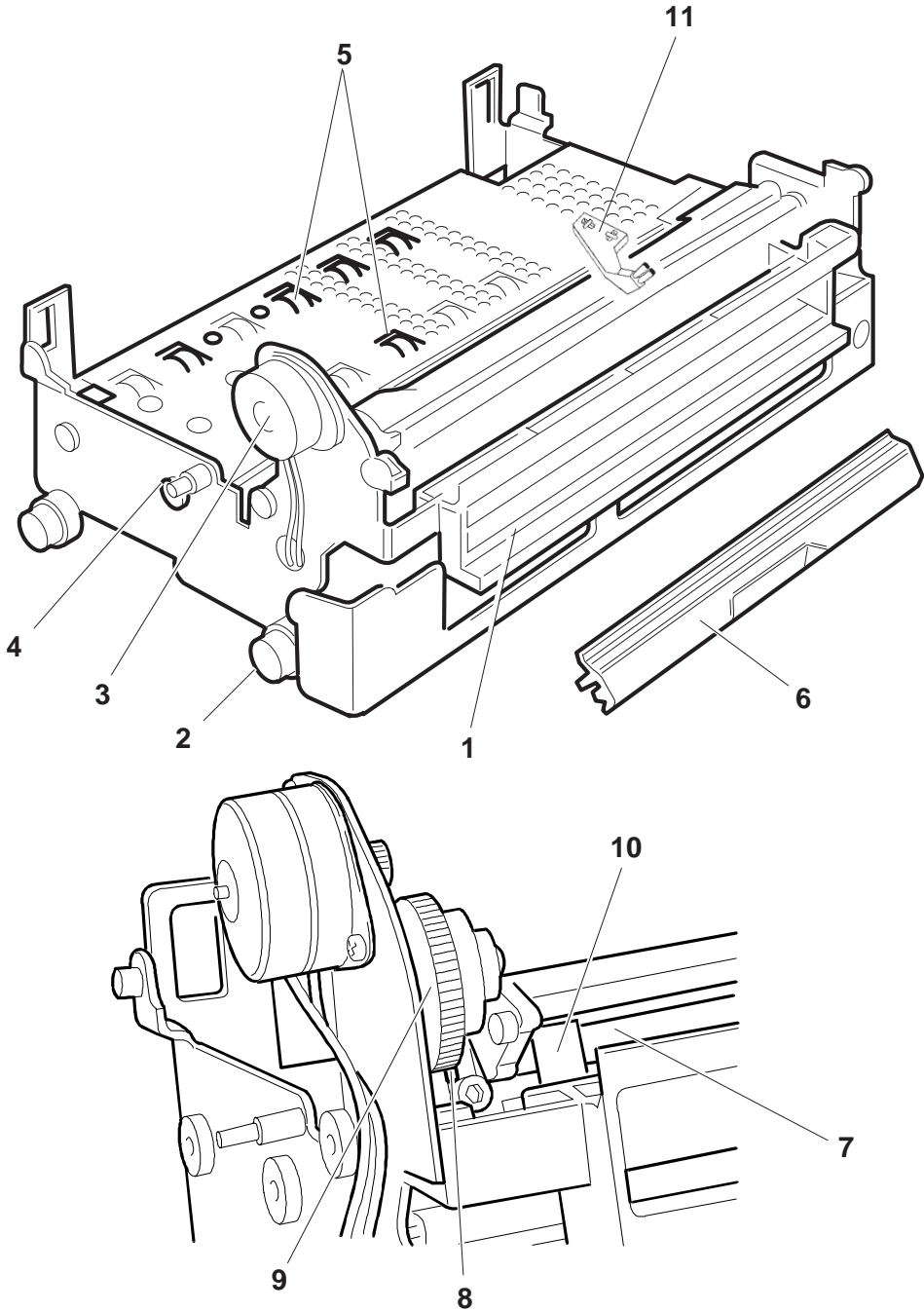
**GRUPPO FONDELLO E ALIMENTATORE  
BASE UNIT AND POWER SUPPLY****PR2/S10**

REF.	CODE	DESCRIZIONE	DESCRIPTION
1	474472 W	GRUPPO FONDELLO	BASE UNIT
2	473034 R	MOLLA CORSOIO INTERRUTTORE	SLIDING SWITCH SPRING
3	473033 Q	CORSOIO INTERRUTTORE	SLIDING SWITCH
4	473108 H	TRASFORMATORE 220/240 V.	220/240 V TRANSFORMER
	475764 B	TRASFORMATORE 240 V. CLASSE B	B CLASS 240 V TRANSFORMER
	473109A	TRASFORMATORE 115 V.	115 V TRANSFORMER
	475765 C	TRASFORMATORE 115 V. CLASSE B	B CLASS 115 V TRANSFORMER
5	473031 N	CONTENITORE GRUPPO RETE	NETWORK UNIT COMPARTMENT
6	473030 Z	SCHERMO PER PIASTRA	BOARD SCREEN
7	473032 P	SCHERMO CONNETTORI	CONNECTOR SCREEN
8	474402 Z	CAVO PIASTRINO ALIMENTAZIONE	CABLE FOR POWER SUPPLY BOARD
9	759413 G	STAFFA FISSAGGIO MECCANICA	MECHANICAL FIXING ROD
10	723349 K	STUD FISSAGGIO TRASFORMATORE	TRANSFORMER FASTENING STUD
11	723352 E	GOMMINO SOSPENSIONE TRASFORMATORE	RUBBER SUPPORT FOR TRANSFORMER
12	5183323 H	INTERRUTTORE RETE	NETWORK SWITCH
13	5358331 H	FUSIBILE 2A-115V-5x20	FUSE 2A-115V-5x20
	5373182 A	FUSIBILE 1,6A-220V-5x20	FUSE 1,6A-220V-5x20
14	471839 T	GRUPPO PRESA RETE	NETWORK SOCKET UNIT
15	475327 V	PIASTRINO ALIMENTATORE	POWER SUPPLY BOARD



**GRUPPO STRUTTURA INFERIORE  
LOWER SECTION****PR2/S10**

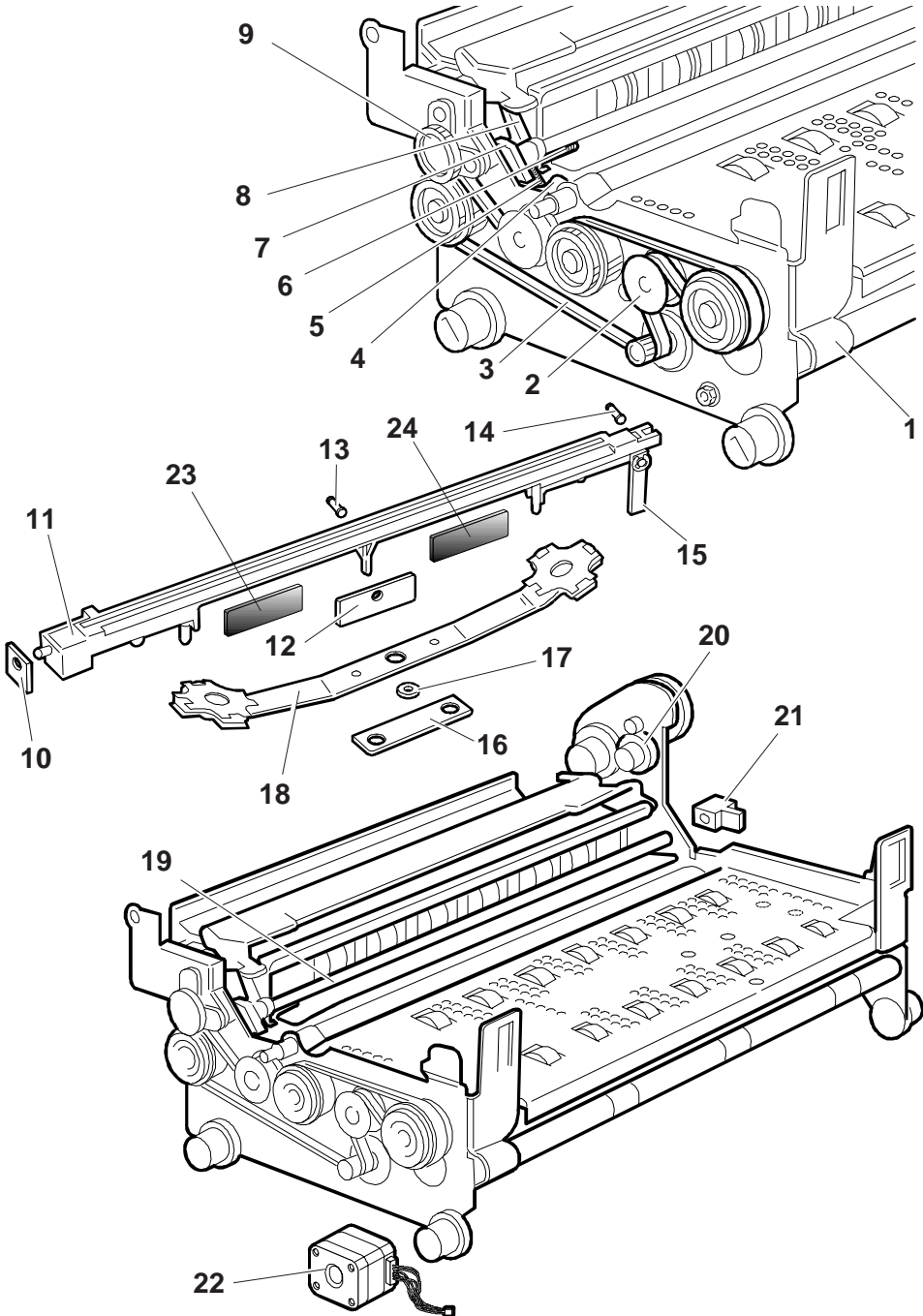
REF.	CODE	DESCRIZIONE	DESCRIPTION
1	473186 P	CONVOGLIATORE CARTA	PAPER FEED
2	473013 L	GOMMINO SMORZATORE STRUTTURA	DAMPING RUBBER FRAME
3	473069 C	GRUPPO MOTORE SERVIZI	MOTOR SERVICE UNIT
4	473018 Z	BOCCOLA SINISTRA	LEFT GUIDE BUSH
5	473028 T	GR. ALBERI DI TRASC. (Npz = 3)	FEED SHAFT GROUP (Pcs = 3)
6	473253 H	SPORTELLA DEFLETTORE	DEFLECTOR FLAP
7	473073 Y	ALBERO SUPPORTO PRESSORI	PRESSURE SUPPORT ARM
8	473074 Z	PONTE COMANDO PRESSORI	LINK FOR PRESSURE MECH.
9	473072 X	CAMMA SERVIZI	SERVICE CAM
10	473075 S	PORTAMOLLA PRESSORI	PRESSURE SPRING HOLDER
11	473037 L	PENNELLO	BRUSH



**GRUPPO STRUTTURA INFERIORE  
LOWER SECTION**

**PR2/S10**

REF.	CODE	DESCRIZIONE	DESCRIPTION
1	473024 P	SCHERMO RULLINI	ROLLER SCREEN
2	473479 C	PULEGGIA TENDICINGHIA	BELT TENSION PULLEY
3	751171 D	CINGHIA TRASC. DOCUM. (Z=210)	DOCUMENT FEED BELT (Z=210)
4	473050 D	BILANCERE COMANDO BANDELLA	FLAP EQUALIZING DRIVE UNIT
5	473052 T	MOLLA GRUPPO BANDELLA	FLAP UNIT SPRING
6	473065 Y	MOLLA LEVA FOTOSENSORI	PHOTOELECTRIC LEVER SPRING
7	473051 S	MANOVELLA COMANDO BANDELLA	FLAP CONTROL MECHANISM
8	473053 U	LEVA FOTOSENSORI SERVIZI	PHOTOELECTRIC SERVICES LEVER
9	473174 S	GR. COMANDO RULLINI PRESSORI	CONTROLS FOR ROLLER PRESSURE
10	473049 G	ZAVORRA SINISTRA	LEFT BALLAST
11	473040 B	GR. TRAVERSA DI STAMPA	PRINTER CROSSFLIGHT UNIT
12	473058 H	ZAVORRA CENTRALE (Npz = 2)	CENTRAL BALLAST (Pcs = 2)
13	473056 X	PERNO PER ZAVORRA CENTRALE	CENTRAL BALLAST PIN
14	473047 W	PERNO PER ZAVORRA DESTRA	RIGHT BALLAST PIN
15	473048 F	ZAVORRA DESTRA	RIGHT BALLAST
16	473063 W	PIASTRINO FISSAGGIO BALESTRA	BALLAST ANCHORAGE PLATE
17	473064 X	RONDELLA PER BARRA	BAR WASHER
18	473059 A	GR. BALESTRA AMMORTIZZ.	SPRING DAMPER UNIT
19	473054 V	GR. BANDELLA PREMICARTA	PAPER PRESSURE FLAP
20	473071 W	INGRANAGGIO DI RINVIO	INTERMEDIATE GEAR
21	473057 Y	LEVA APERTURA BANDELLA	FLAP OPENING LEVER
22	473020 X	GRUPPO MOTORE INTERLINEA	LINE SPACING MOTOR UNIT
23	473066 Z	SILENZIATORE TRAVERSA STAMPA POST.	FRONT PRINTING BAR DAMPENING (10 x 70)
24	473067 S	SILENZIATORE TRAVERSA STAMPA ANT.	REAR PRINTING BAR DAMPENING (6 x 70)

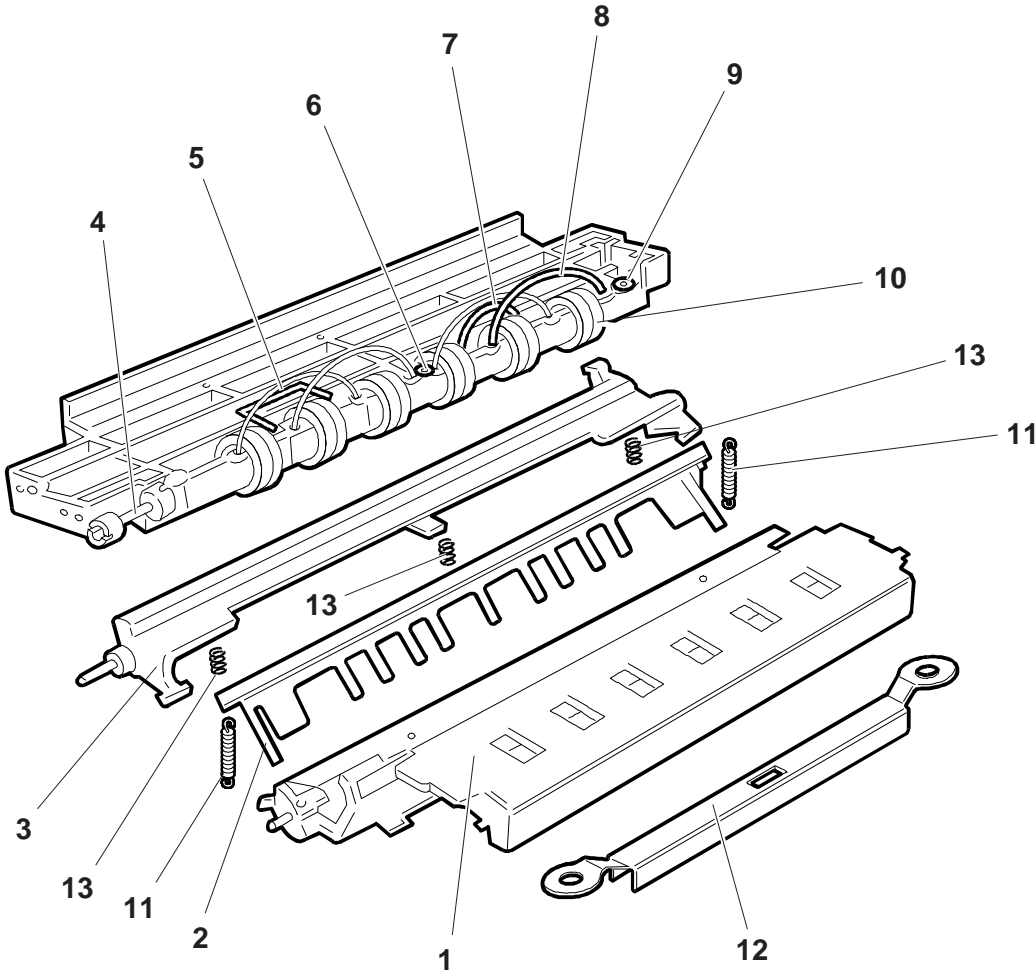


**GRUPPO STRUTTURA INFERIORE  
LOWER SECTION**

**PR2/S10  
PR2/S10**

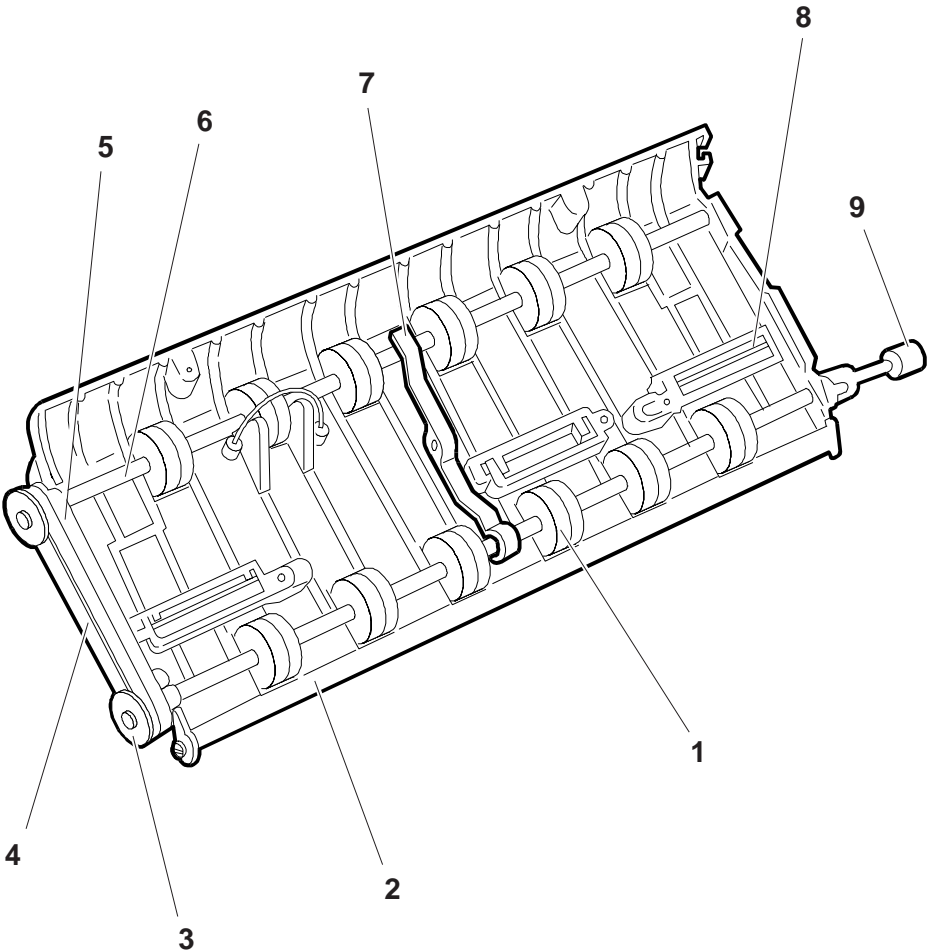
REF.	CODE	DESCRIZIONE	DESCRIPTION
1	473085 M	SUPPORTO CARTA FOTO ANTERIORE	FRONT PHOTO SUPPORT
2	473077 U	PETTINE	COMB
3	474954 Z	SUPPORTO PETTINE	SUPPORT FOR COMB
4	473175 T	GIUNTO	JOINT
5	473091 K	MOLLA RULLINI ALLINEAMENTO	ALIGNMENT ROLLER SPRING
6	473088 Y	BOCCOLA CENTRALE	CENTRAL GUIDE BUSH
7	473192 M	FIBRA OTTICA L=80	OPTICAL FIBER L=80
8	473191 L	FIBRA OTTICA L=100	OPTICAL FIBER L=100
9	473087 P	BOCCOLA LATERALE	SIDE GUIDE BUSH
10	473240 Q	GRUPPO RULLINI ALLINEAMENTO	ALIGNMENT ROLLERS UNIT
11	473265 D	MOLLA PETTINE (Npz = 2)	COMB SPRING (Pcs = 2)
12	473332 Y	TRAVERSA DI SUPPORTO FOTO	PHOTO SUPPORT BAR
13	473083 K	MOLLA PRESSORE (Npz = 3)	PRESSURE SPRING (Pcs = 3)



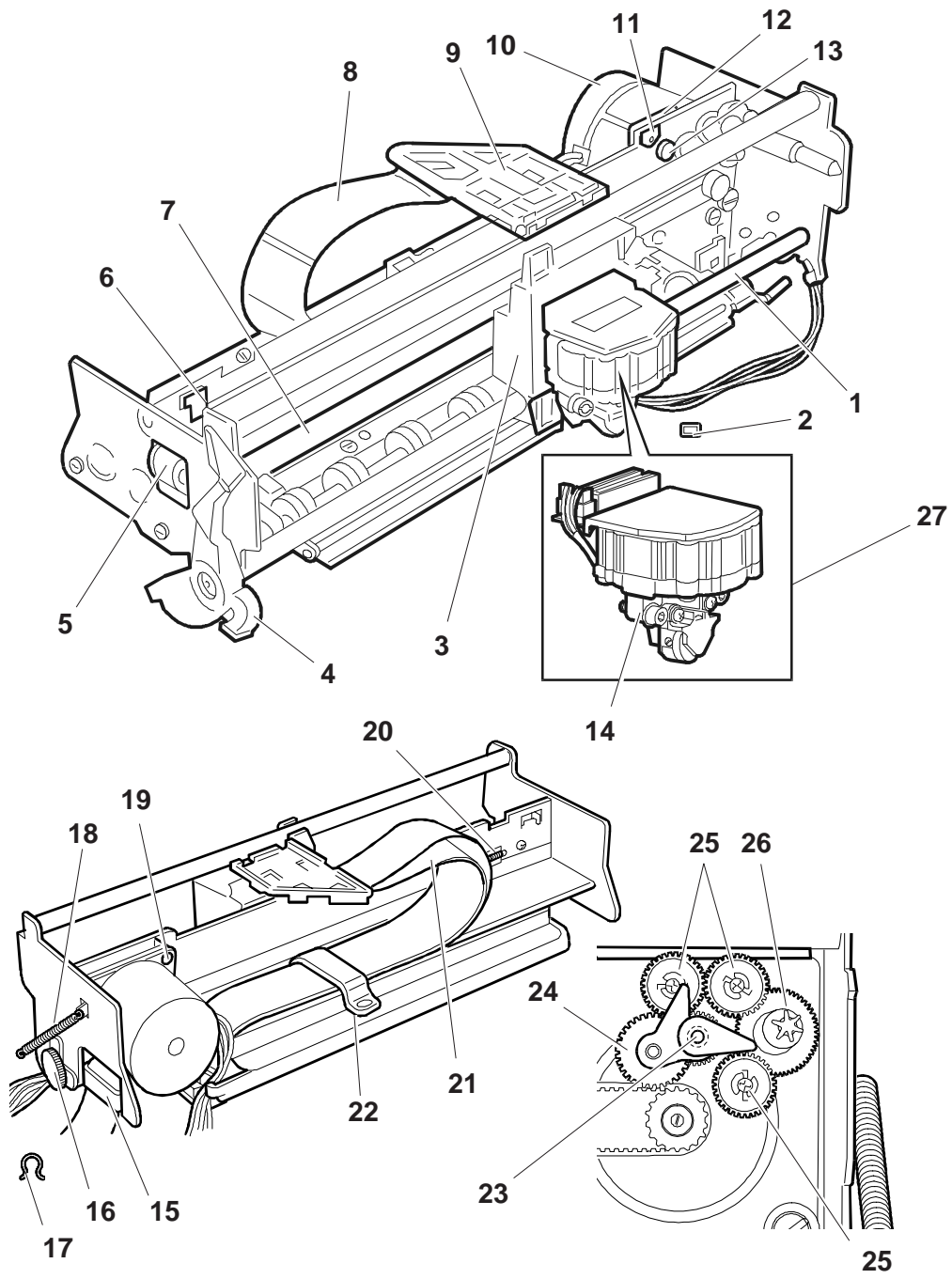


**GRUPPO PRESSORI POSTERIORI**  
**REAR PRESSURE UNIT****PR2/S10**

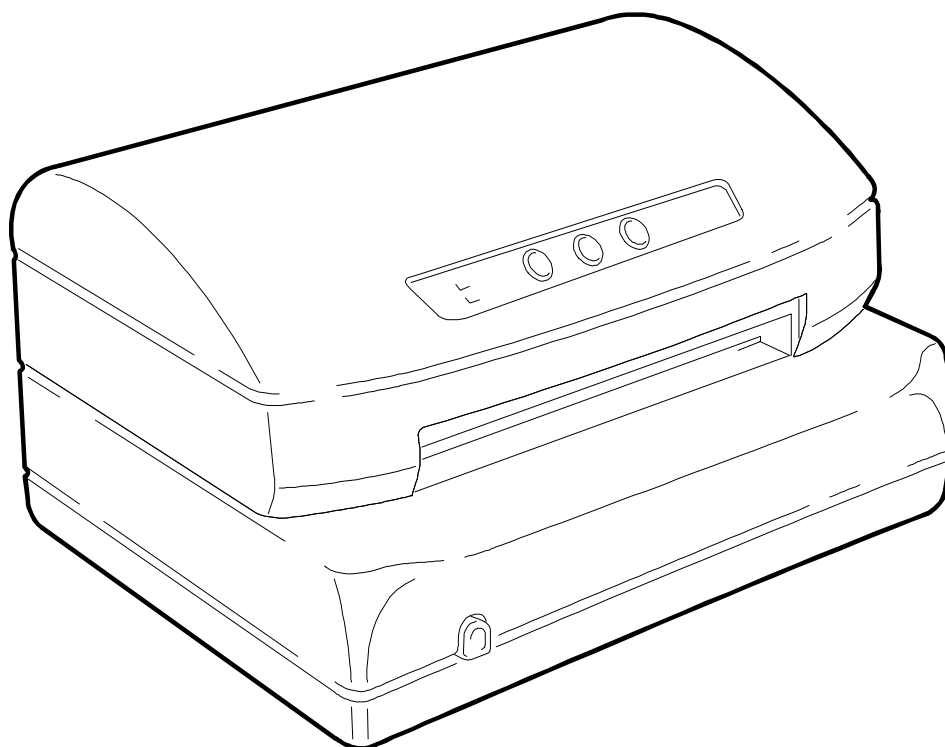
REF.	CODE	DESCRIZIONE	DESCRIPTION
1	473244 G	GRUPPO RULLINI ANTERIORI	FRONTS ROLLER UNIT
2	473160 G	SUPPORTO PRESSORI	PRESSURE UNITS SUPPORT
3	473166 S	PULEGGIA	PULLEY
4	473172 Y	CINGHIA DENTATA Z=88	COGGED BELT Z=88
5	473171 X	BOCCOLA SINISTRA	LEFT GUIDE BUSH
6	473248 L	GRUPPO RULLINI PRESSORI POSTERIORI	REAR PRESSURE ROLLERS UNIT
7	473167 T	BOCCOLA CENTRALE	CENTRAL GUIDE BUSH
8	473173 Z	MOLLA TORSIONE ((Npz = 3)	TORSION SPRING (Pcs = 3)
9	473175 T	GIUNTO	JOINT



REF.	CODE	DESCRIZIONE	DESCRIPTION
1	473127 K	ALBERO SUPPORTO CARRELLO	CARRIAGE SUPPORT SHAFT
2	473150 E	FELTRO LUBRIFICAZIONE CARRELLO	CARRIAGE LUBRICATING PAD
3	473130 S	CARRELLO SUPPORTO TESTINA	HEAD SUPPORT CARRIAGE
4	473129 V	LEVA APERTURA STRUTTURA SUP.	OPENING LEVER FOR UPPER SEC.
5	751272 J	PULEGGIA DI RINVIO	SNUB PULLEY
6	473149 H	SUPPORTO TENDICINGHIA	BELT TENSION SUPPORT
7	473123 P	CINGHIA TRASPORTO CARRELLO	CARRIAGE MOVEMENT BELT
8	473135 K	SCHERMO FLAT TESTINA	PRINT HEAD FLAT CABLE SCREEN
9	473137 M	SUPPORTO FLAT	SUPPORT FOR FLAT CABLE
10	473140 C	GRUPPO MOTORE TRASPORTO	TRANSPORT MOTOR UNIT
11	473156 Y	STAFFA COLLEG. TERRA	EARTH ROD
12	473141 Z	AMMORT. MOTORE TRASPORTO	TRANSPORT MOTOR DAMPER
13	471244 E	STUD PER FISSAGGIO MOTORE	MOTOR ANCHORAGE STUD
14	475287 W	GR. FOTOSENS. TASTATURA	SENSOR HEAD PHOTOELEC. UNIT
15	473139 X	STAFFA DX GUIDA FLAT	RIGHT FLAT CABLE GUIDE ROD
16	473180 V	GR. COMANDO RULLINI PRESS.	PRESSURE ROLLER DRIVE UNIT
17	473182 K	BALESTRINA PER GR. BOCCOLA	BUSH UNIT LEAF SPRING
18	473151 T	MOLLA PER LEVA DI BLOCC.	LOCKING LEVER SPRING
19	710769 X	PIASTRINO FISS. MOTORE TRASP.	TRANSP. MOTOR ANCHOR. PLATE
20	473155 X	MOLLA TENDICINGHIA	BELT TENSION SPRING
21	474400 B	FLAT TESTINA	PRINT HEAD FLAT CABLE
22	473138 W	STAFFA BLOCCAGGIO FLAT	FLAT CABLE ANCHORAGE ROD
23	473498 Y	SCAMBIATORE	EXCHANGER
24	473131 P	INGRANAGGIO COMANDO NASTRO	RIBBON DRIVE GEAR
25	753720 R	RUOTA TRASCIN. NASTRO	RIBBON FEED WHEEL
26	473159 B	LANCIA	LANCE
27	150376 L	GR. TESTINA DI STAMPA	PRINT HEAD UNIT







**PR2/S12 - MACCHINA BASE +  
MAGNETICO ORIZZONTALE**

**PR2/S12 - STANDARD VERSION +  
HORIZONTAL MAGNETIC DEVICE**

**GRUPPO STRUTTURA INF. CON MAGNETICO ORIZZ.  
LOWER SECTION WITH HORIZ. MAGN. READER DEVICE**

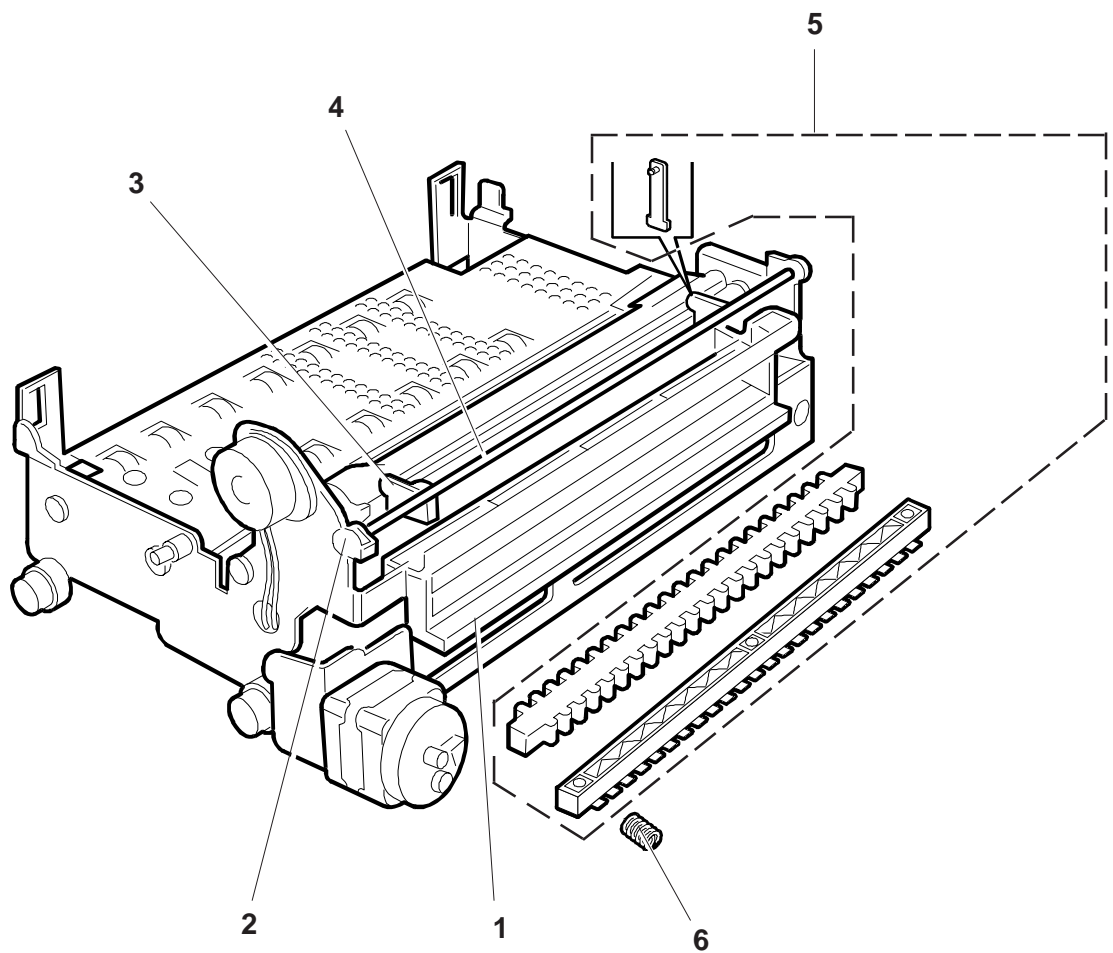
**PR2/S12**

REF.	CODE	DESCRIZIONE	DESCRIPTION
1	474951 W	CONVOGLIATORE CARTA PER MAGN. ORIZZ.	PAPER FEED FOR HOR.MAG. READER DEVICE
2	473315 X	MANOVELLA PER CAMMA	CAM LEVER
3	473317 Z	MANOVELLA PRESSORE	PRESSURE LEVER
4	473314 W	ALBERO SUPPORTO PRESSORE	PRESSURE SUPPORT ARM
5	473499 Z	GRUPPO TRAVERSA PRESSORE	PRESSURE BAR UNIT
6	473320 G	MOLLA PRESSORE	PRESSURE SPRING

**NOTA:** Per le parti comuni fare riferimento alla PR2/S10 MACCHINA BASE descritta in precedenza.

**NOTE:** For parts common to the Standard version PR2/S10 please refer to the preceding section.

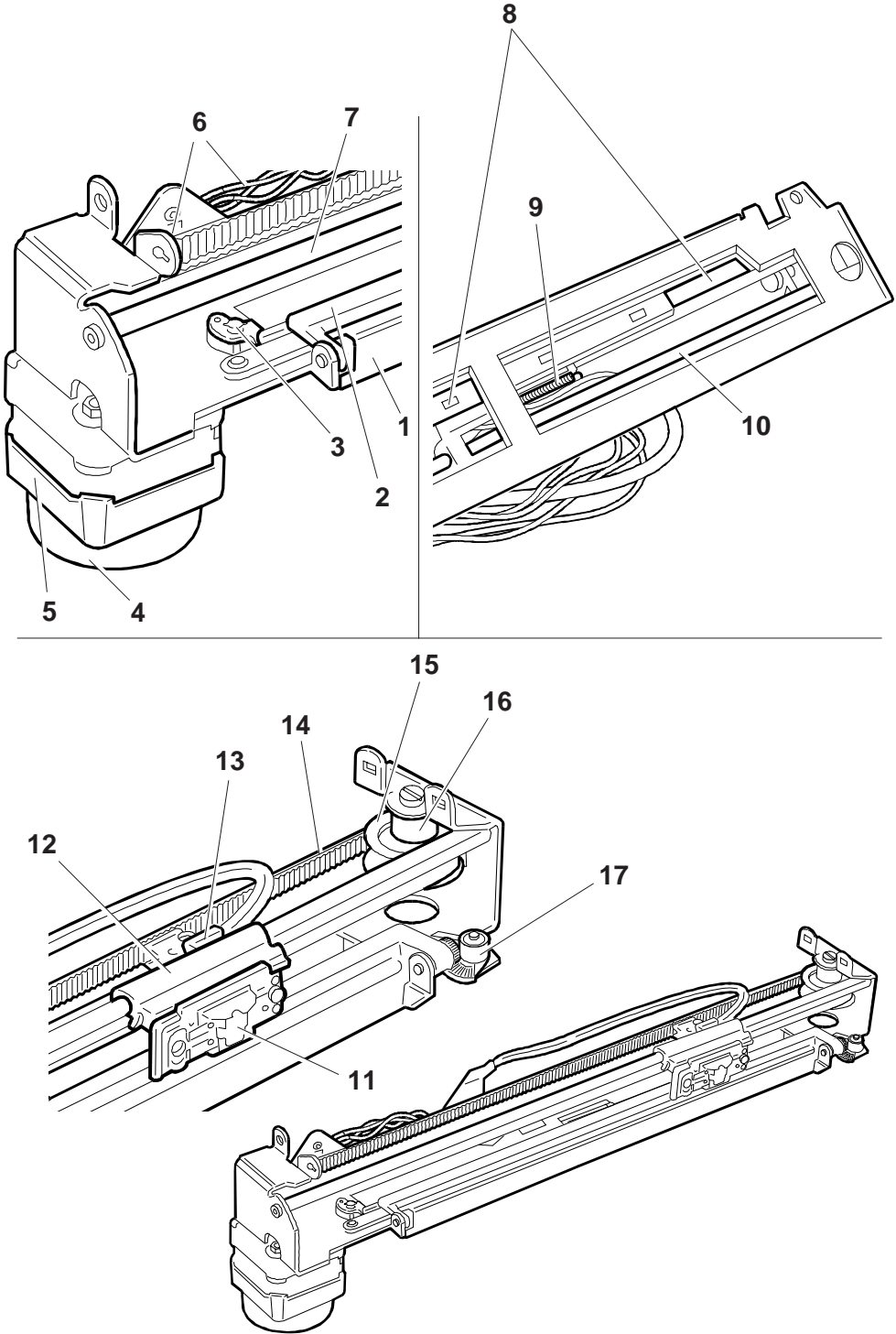




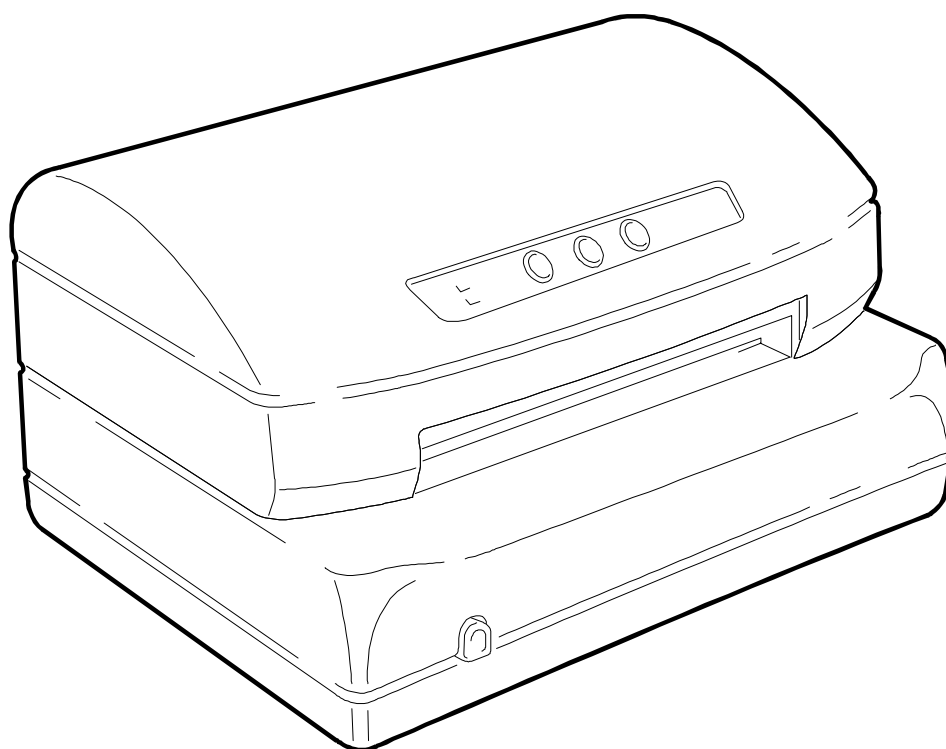
**GRUPPO MAGNETICO ORIZZONTALE  
HORIZONTAL MAGNETIC DEVICE**

**PR2/S12**

REF.	CODE	DESCRIZIONE	DESCRIPTION
1	473485 K	GR. STRUTTURA MAGN. ORIZZ.	HORIZ. MAG. READER DEVICE
2	473486 L	SPORTELLO DI CHIUSURA	COVER
3	473285 S	PONTE APERTURA SPORTELLO	FLAP OPENING JOINT
4	710682 H	SMORZATORE MOTORE TRASPORTO	TRANSPORT MOTOR DAMPER
5	473308 R	GRUPPO MOTORE TRASPORTO MAGN. ORIZZ.	HORIZ. MAG. TRANSPORT MOTOR UNIT
6	473330 A	GRUPPO FOTO AZZERAMENTO	PHOTO INITIALIZING UNIT
7	473312 U	BARRA GUIDA SUPERIORE (L=357)	UPPER TRACK (L=357)
8	473309 J	GRUPPO SEMITIRANTE	BRACE GROUP
9	471514 M	MOLLA CHIUSURA SPORTELLO	FLAP CLOSING SPRING
10	473313 V	BARRA GUIDA INFERIORE (L=327)	LOWER TRACK (L=327)
11	471530 Z	GRUPPO TESTINA MAGNETICA ORIZZ.	HORIZ. MAG. DEVICE HEAD UNIT
12	474952 X	CARRELLO TESTINA MAGNETICA	HEAD CARRIAGE
13	471501 Z	STAFFA BLOCCAGGIO TEST. MAGNETICA	LOCKING MAGNETIC HEAD UNIT
14	473311 T	CINGHIA MAGNETICO ORIZZ. (Z=360)	HORIZ. MAG. DEVICE BELT (Z=360)
15	473302 B	PULEGGIA DI RINVIO	SNUB PULLEY
16	473301 A	PERNO PER PULEGGIA	PULLEY PIN
17	473303 C	SETTORE DENTATO	SECTOR GEAR







**PR2/S13 - MACCHINA BASE + MAGNETICO  
VERTICALE**

**PR2/S13 - STANDARD VERSION + VERTICAL  
MAGNETIC DEVICE**

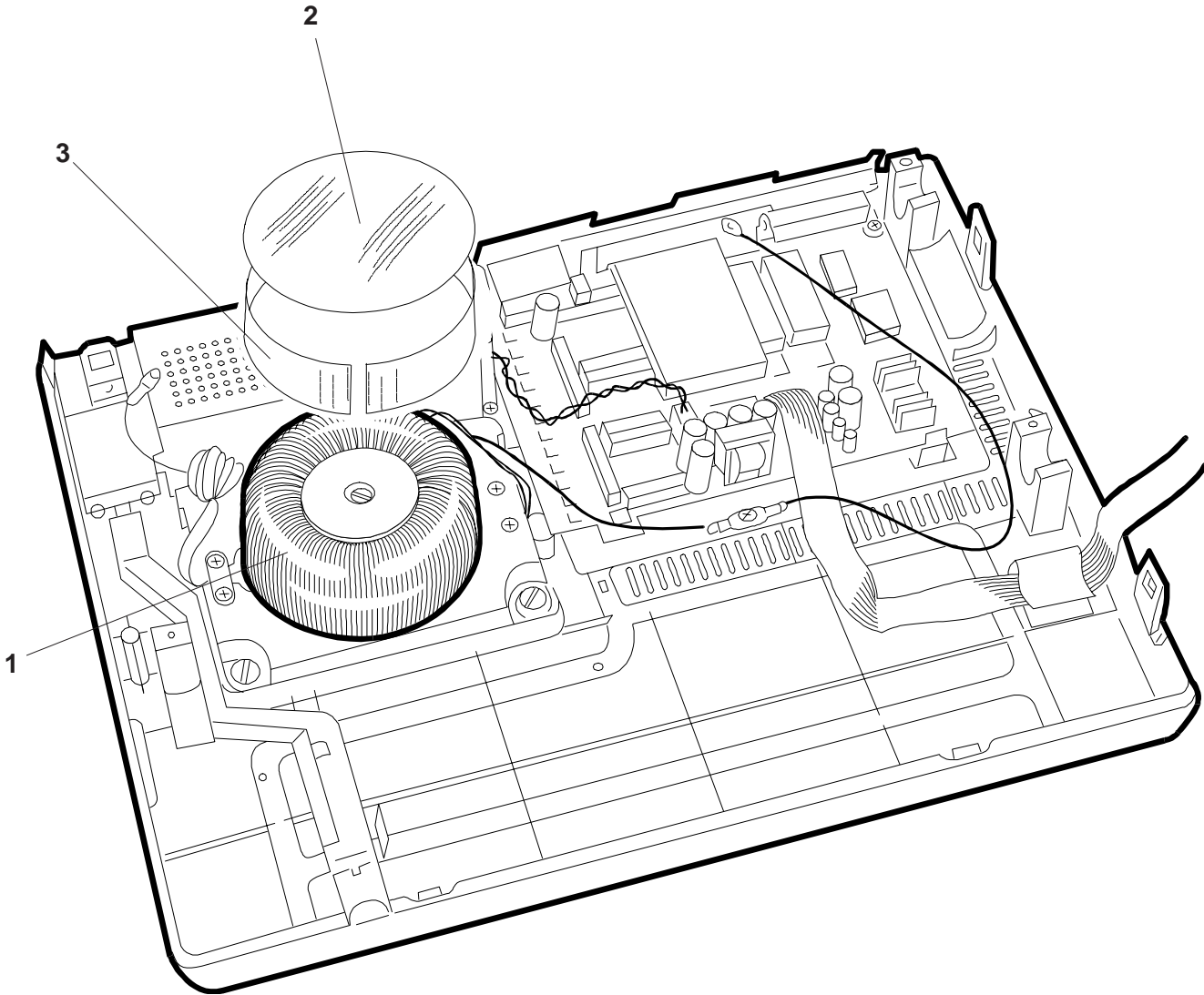
**GRUPPO FONDELLO E ALIMENTATORE CON M.V.  
UNIT BASE AND POWER SUPPLY FOR V.M.**

**PR2/S13**

REF.	CODE	DESCRIZIONE	DESCRIPTION
1	473108 H 473109 A	GRUPPO TRASFORMATORE 220-240V GRUPPO TRASFORMATORE 115V	220-240V TRANSFORMER ASSEMBLY 115V TRANSFORMER ASSEMBLY
2	473493 K	MYLAR PROTEZ. SUPER. TRASF. M.V. SX	LEFT V. M. TRASF. UPPER PROTECT. MYLAR
3	473494 L	MYLAR PROTEZ. LATER. TRASF. M.V. SX	LEFT V. M. TRASF. SIDE PROTECT. MYLAR

**NOTA:** Per le parti comuni fare riferimento alla PR2/S10 MACCHINA BASE descritta in precedenza.

**NOTE:** For parts common to the Standard version PR2/S10 please refer to the preceding section.

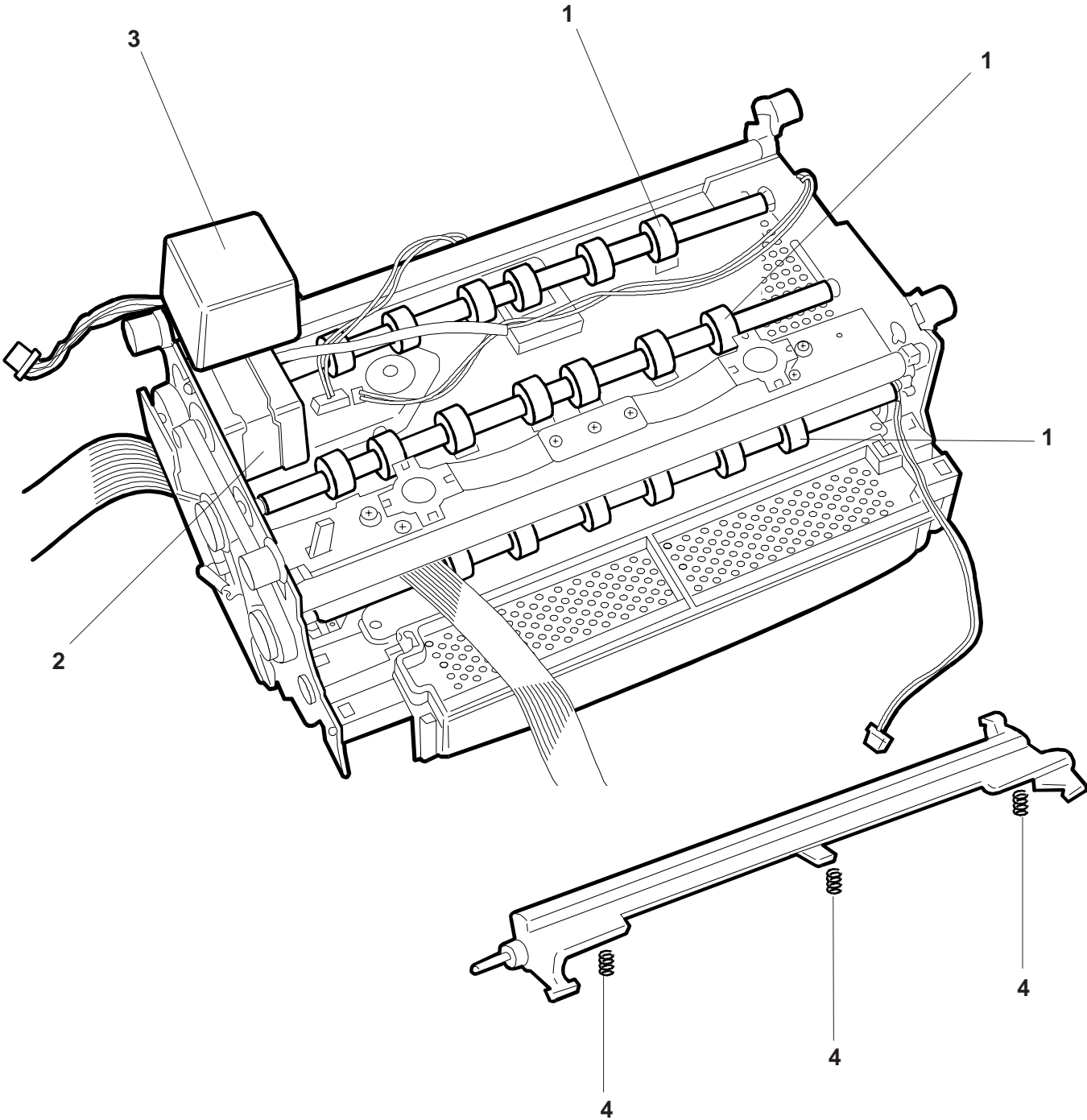


**GRUPPO STRUTTURA INFERIORE CON M.V.**  
**LOWER SECTION GROUP FOR V.M.**

**PR2/S13**

REF.	CODE	DESCRIZIONE	DESCRIPTION
1	473376 C 473396 Z	GR. ALBERI TRASCINAMENTO M.V. SX GR. ALBERI TRASCINAMENTO M.V. DX	LEFT VERTIC. MAGN. FEED SHAFT GROUP RIGHT VERTIC. MAGN. FEED SHAFT GROUP
2	473395 Y	MOTORE INTERLINEA MAGN. VERTIC.	VERTIC. MAGN. LINE SPACING MOTOR
3	473346 E	SCHERMO MOTORE MAGN. VERTIC. DX	RIGHT VERTIC. MAGN. MOTOR SHIELD
4	473083 K	MOLLA PRESSORE (Npz = 3)	PRESSURE SPRING (Pcs = 3)

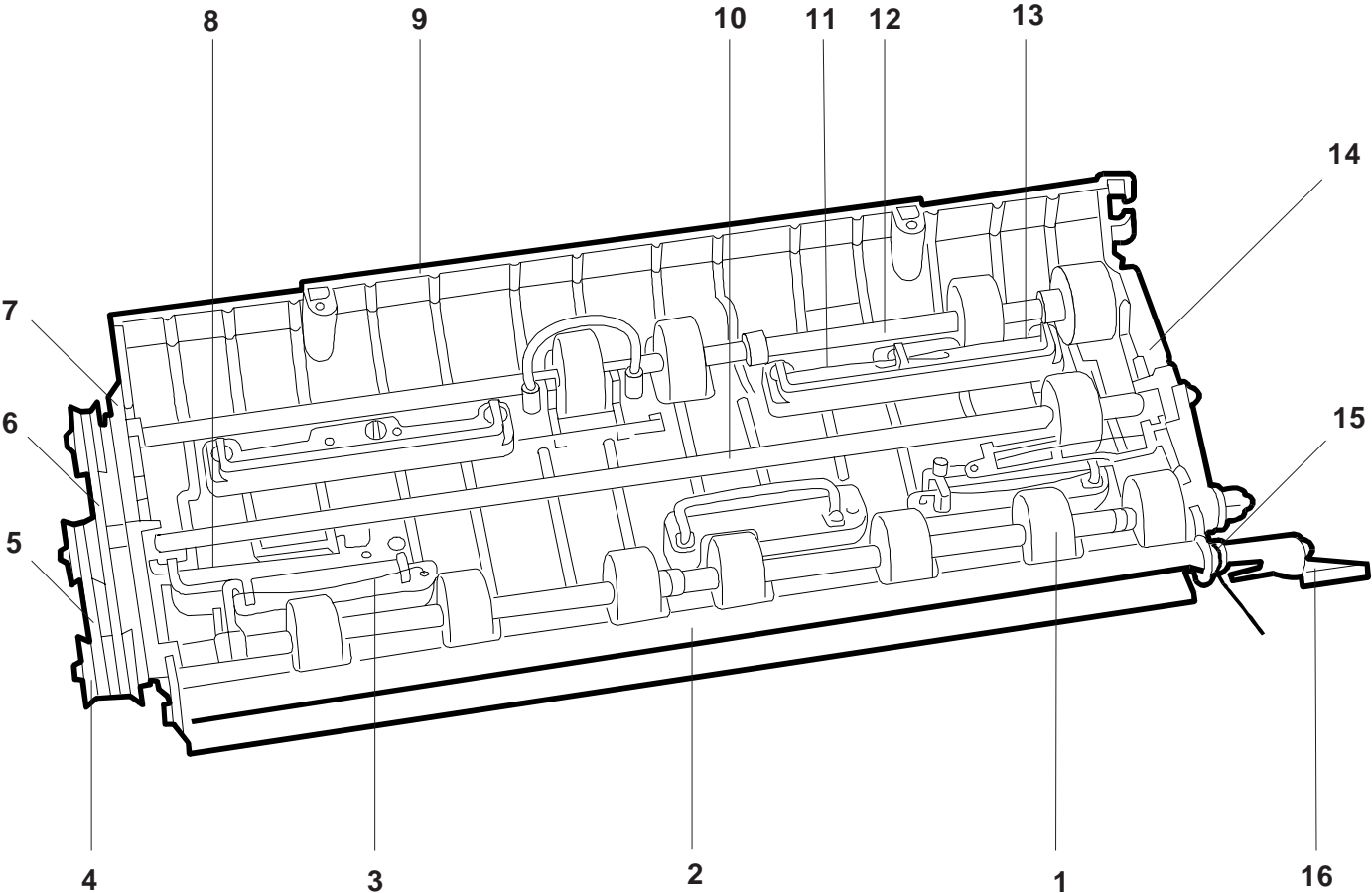




**GRUPPO PRESSORI POSTERIORI**  
**REAR PRESSURE UNIT**

**PR2/S13**

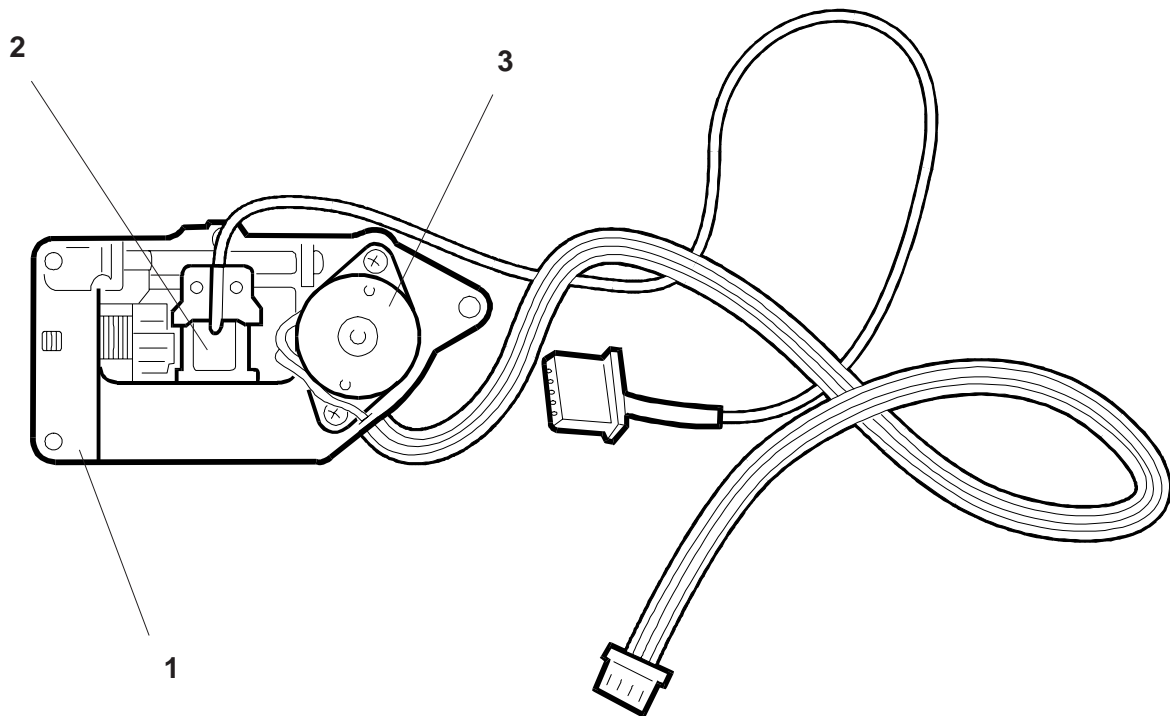
REF.	CODE	DESCRIZIONE	DESCRIPTION
1	473364 G 473383 U	GR. RULLINI ANTERIORI M.V. SX GR. RULLINI ANTERIORI M.V. DX	LEFT VERTIC. MAGN. FRONTS ROLLER UNIT RIGHT VERTIC. MAGN. FRONTS ROLLER UNIT
2	473390 F	GRUPPO MYLAR PER MAGN. VERTIC.	VERTIC. MAGN. MYLAR GROUP
3	473378 N	BARRA DI TORSIONE - VERDE (Npz = 2)	TORSION BAR - GREEN (Pcs = 2)
4	473370 J	PULEGGIA PER MAGN. VERTICALE	VERTIC. MAGN. PULLEY
5	473353 D	CINGHIA DENTATA Z=55	BELT TIMING Z=55
6	473348 Q	CINGHIA DENTATA Z=88	BELT TIMING Z=88
7	473355 F	SUPPORTO ALBERO	SHAFT SUPPORT
8	473298 F	BARRA DI TORSIONE - GIALLO (Npz = 2)	TORSION BAR - YELLOW (Pcs = 2)
9	473354 E 473382 T	SUPPORTO PRESSORI M.V. SX SUPPORTO PRESSORI M.V. DX	LEFT VERTIC. MAGN. PRESSURE SUPPORT RIGHT VERTIC. MAGN. PRESSURE SUPPORT
10	473372 G 473386 X	GRUPPO ALBERO CONTRASTO M.V. SX GRUPPO ALBERO CONTRASTO M.V. DX	LEFT VERT.MAGN. CONTRAST SHAFT GROUP RIGHT VERT.MAGN. CONTRAST SHAFT GROUP
11	473295 U	BARRA DI TORSIONE - ROSSO (Npz = 1)	TORSION BAR - RED (Pcs = 1)
12	473366 A 473385 W	GR. ALBERO POSTERIORE M.V. SX GR. ALBERO POSTERIORE M.V. DX	LEFT VERTIC. MAGN. REAR SHAFT GROUP RIGHT VERTIC. MAGN. REAR SHAFT GROUP
13	473296 V	BARRA DI TORSIONE - BLU (Npz = 1)	TORSION BAR - BLUE ((Pcs = 1)
14	473356 G	BOCCOLA PRESSORE M.V.	VERTIC. MAGN. PRESSURE BUSH
15	473394 X	MOLLA A SPILLO M.V.	VERTIC. MAGN. PIN SPRING
16	473393 W	MANOVELLA M.V.	VERTIC. MAGN. HANDLE

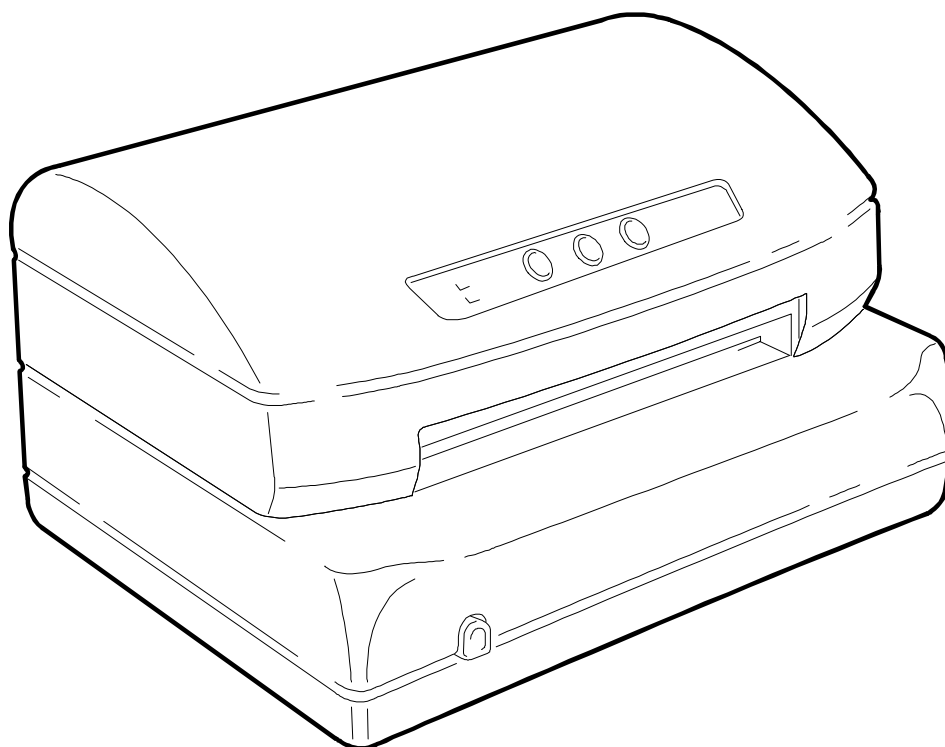


**GRUPPO MAGNETICO VERTICALE  
VERTICAL MAGNETIC DEVICE GROUP**

**PR2/S13**

REF.	CODE	DESCRIZIONE	DESCRIPTION
1	150370 S	GR. SUPPORTO MAGN. VERTIC.	VERTIC. MAG. SUPPORT GROUP
2	473351 B	GR. TESTINA MAGNETICA MAGN. VERTIC.	VERTIC. MAGN. DEVICE HEAD UNIT
3	473344 C	GRUPPO MOTORE MAGN. VERTIC.	VERTIC. MAGN. MOTOR UNIT





**PR2/S12 M - MACCHINA BASE +  
MAGNETICO ORIZZONTALE + MICR**

**PR2/S12 M - STANDARD VERSION +  
HORIZONTAL MAGNETIC DEVICE + MICR**

**GR. STRUTTURA INF. CON MAGNET. ORIZZ. E CON MICR  
LOWER SECTION WITH HORIZ. MAGN. READER DEVICE WITH MICR**

**PR2/S12 M**

REF.	CODE	DESCRIZIONE	DESCRIPTION
1	474951 W	CONVOGLIATORE CARTA PER MAGN. ORIZZ.	PAPER FEED FOR HOR.MAG. READER DEVICE
2	473315 X	MANOVELLA PER CAMMA	CAM LEVER
3	473317 Z	MANOVELLA PRESSORE	PRESSURE LEVER
4	473314 W	ALBERO SUPPORTO PRESSORE	PRESSURE SUPPORT ARM
5	473499 Z	GRUPPO TRAVERSA PRESSORE	PRESSURE BAR UNIT
6	473320 G	MOLLA PRESSORE	PRESSURE SPRING

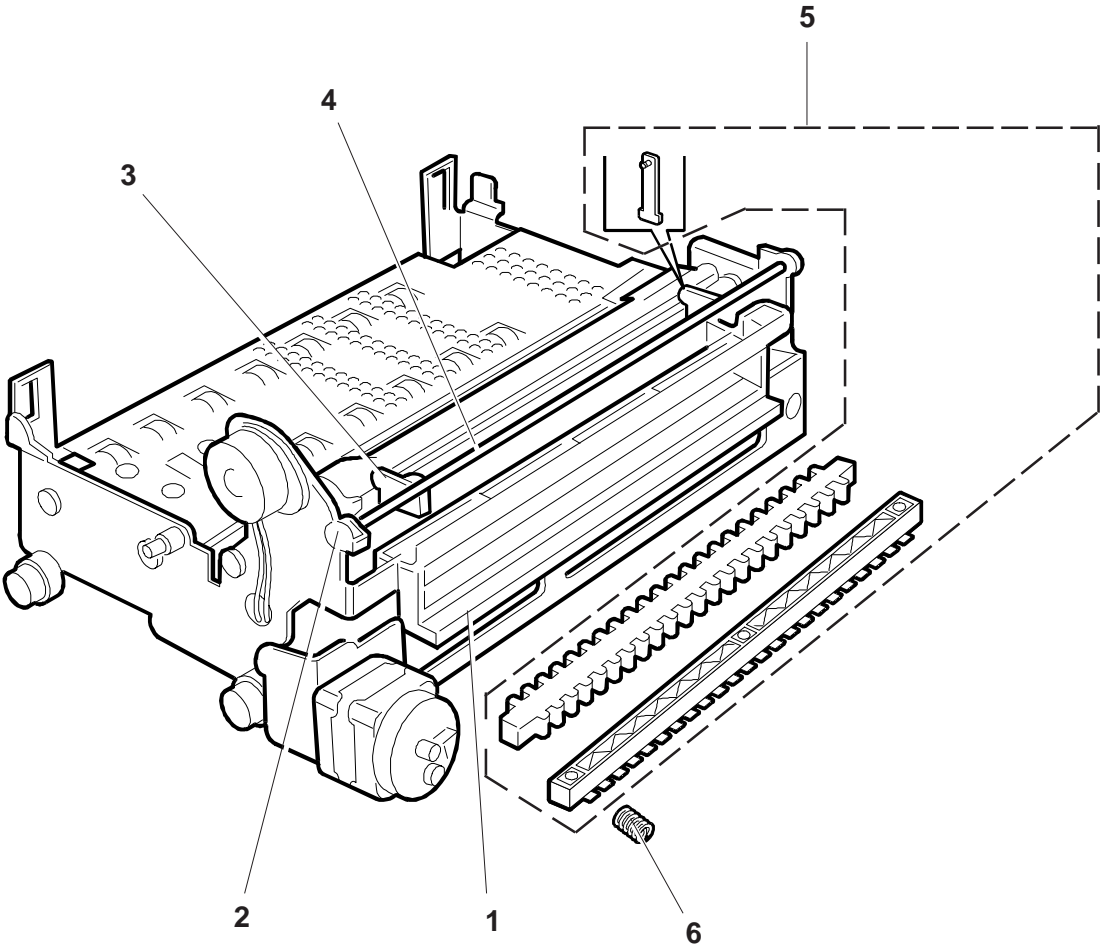
**NOTA:** Per le parti comuni fare riferimento alla PR2/S10 MACCHINA BASE descritta in precedenza.

**NOTE:** For parts common to the Standard version PR2/S10 please refer to the preceding section.

**GR. STRUTTURA INF. CON MAGNET. ORIZZ. E CON MICR**  
**LOWER SECTION WITH HORIZ. MAGN. READER DEVICE WITH MICR**

---

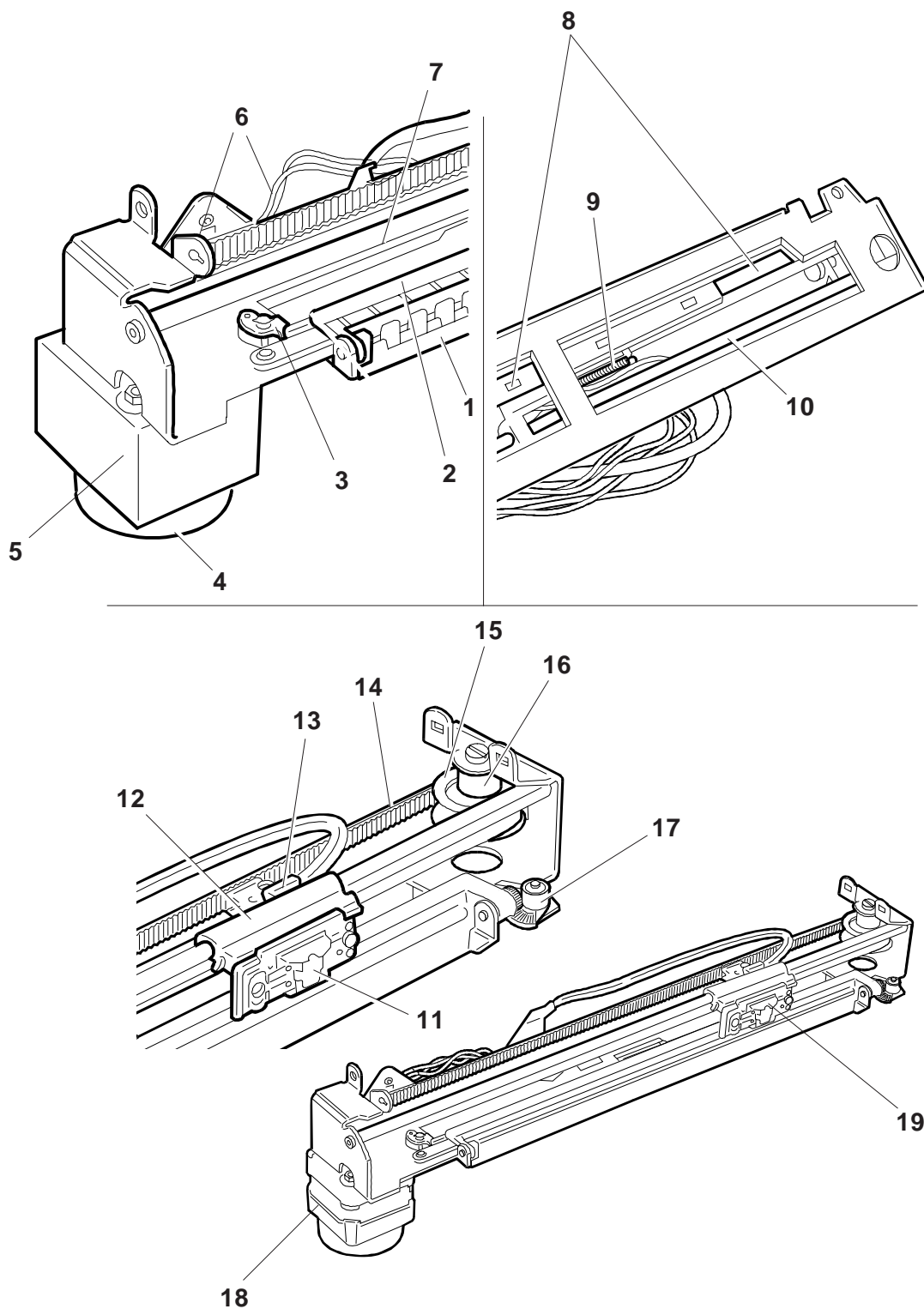
PR2/S12 M



**GRUPPO MAGNETICO ORIZZONTALE  
HORIZONTAL MAGNETIC DEVICE****PR2/S12 M**

REF.	CODE	DESCRIZIONE	DESCRIPTION
1	473485 K	GR. STRUTTURA MAGN. ORIZZ. + MICR	HORIZ. MAG. READER DEVICE + MICR
2	473486 L	SPORTELLO DI CHIUSURA	COVER
3	473285 S	PONTE APERTURA SPORTELLO	FLAP OPENING JOINT
4	710682 H	SMORZATORE MOTORE TRASPORTO	TRANSPORT MOTOR DAMPER
5	473487 M	SCHERMO MOTORE MAGN. ORIZZ. / MICR	HORIZ. MAG. / MICR MOTOR SHIELD
6	473330 A	GRUPPO FOTO AZZERAMENTO	PHOTO INITIALIZING UNIT
7	473312 U	BARRA GUIDA SUPERIORE (L=357)	UPPER TRACK (L=357)
8	473309 J	GRUPPO SEMITIRANTE	BRACE GROUP
9	471514 M	MOLLA CHIUSURA SPORTELLO	FLAP CLOSING SPRING
10	473313 V	BARRA GUIDA INFERIORE (L=327)	LOWER TRACK (L=327)
11	473480 S	GR. TESTINA MAGN. ORIZZ. + MICR	HORIZ. MAG. DEVICE + MICR HEAD UNIT
12	474952 X	CARRELLO TESTINA MAGNETICA	HEAD CARRIAGE
13	471501 Z	STAFFA BLOCCAGGIO TEST. MAGNETICA	LOCKING MAGNETIC HEAD UNIT
14	473311 T	CINGHIA MAGNETICO ORIZZ. (Z=360)	HORIZ. MAG. DEVICE BELT (Z=360)
15	473302 B	PULEGGIA DI RINVIO	SNUB PULLEY
16	473301 A	PERNO PER PULEGGIA	PULLEY PIN
17	473303 C	SETTORE DENTATO	SECTOR GEAR
18	473308 R	GR. MOTORE TRASP. MAGN. ORIZZ. + MICR	HORIZ. MAG. + MICR TRANSPORT MOTOR UNIT
19	473483 R	SCHERMO TESTINA MICR	MICR HEAD SHIELD



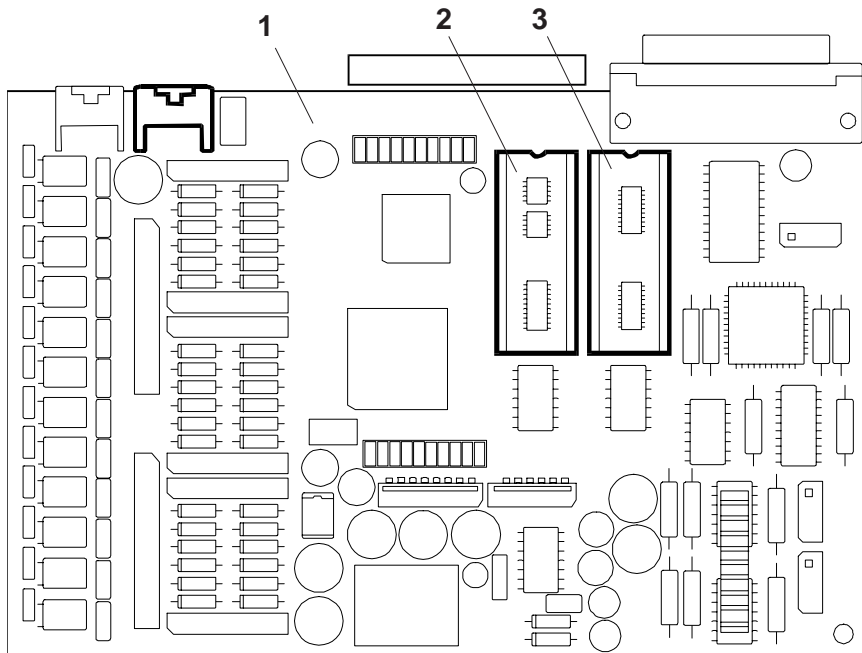


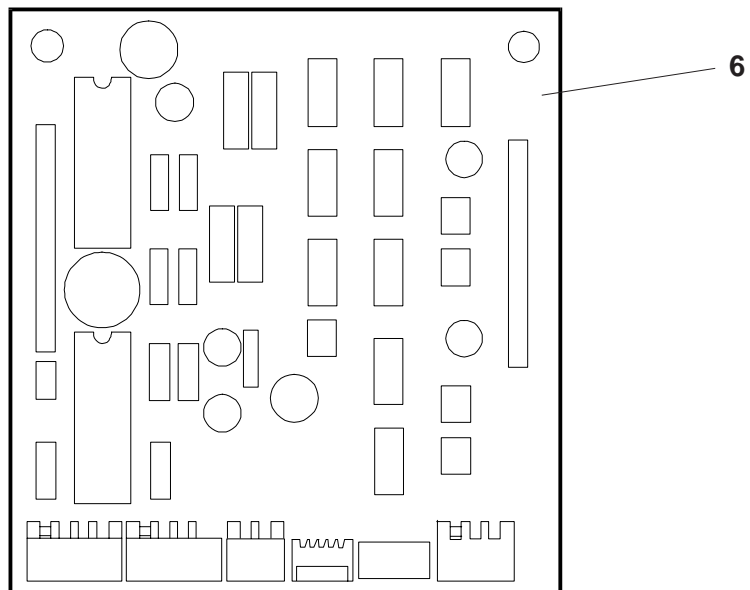
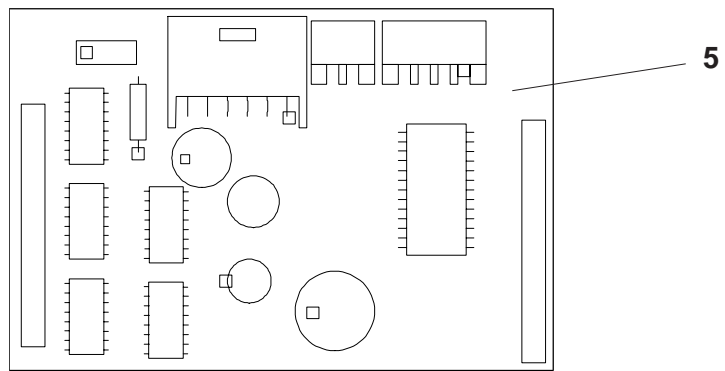
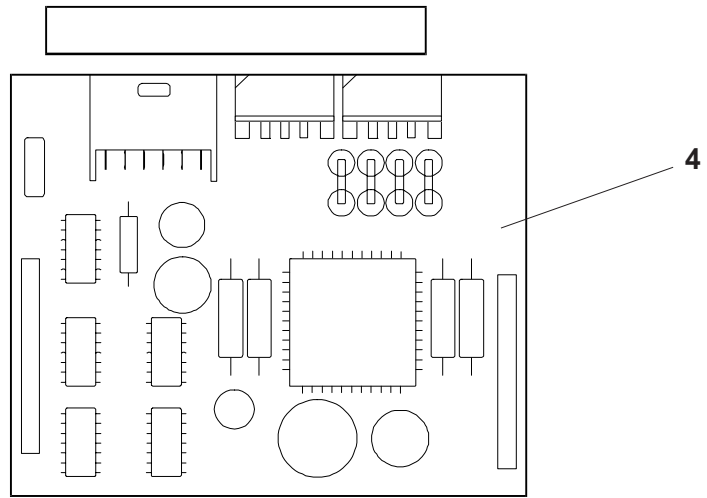


**PR2/S10-S12-S12M-S13 - PIASTRE ELETTRONICHE**

**PR2/S10-S12-S12M-S13 - ELECTRONIC BOARDS**

REF.	CODE	DESCRIZIONE	DESCRIPTION
1	566998 S	BAPR2STD - PIASTRA BASE SERIALE	SERIAL BASE BOARD BAPR2STD
2	474651 H 474537 P 150418 F	EPROM "PE 76" FIRMWARE STANDARD EPROM "PE 64" FIRMWARE DAECO FLASH EPROM PREINCISA	STANDARD EPROM FIRMWARE "PE 76" DAECO EPROM FIRMWARE "PE 64" PRE-RECORDED FLASH EPROM
3	474415 M 474417 P	EPROM "PE 56" GEN. CARATTERI STAND. EPROM "PE 58" GEN. CARATTERI DAECO	STANDARD EPROM "PE 56" GEN. CHARS. DAECO EPROM "PE 58" GEN. CHARS.
4	474552 W	PR2 MAGN. PIASTRINO MAGN.ORIZZ.	PR2 MAGN. BOARD HORIZ. MAGN. DEVICE
5	474396 S	PR2 VER. PIASTRINO MAGN.VERTIC.	PR2 VER. BOARD VERTIC. MAGN. DEVICE
6	474636 S	PIASTRINO MICR + MAGN.	BOARD MICR + MAG.

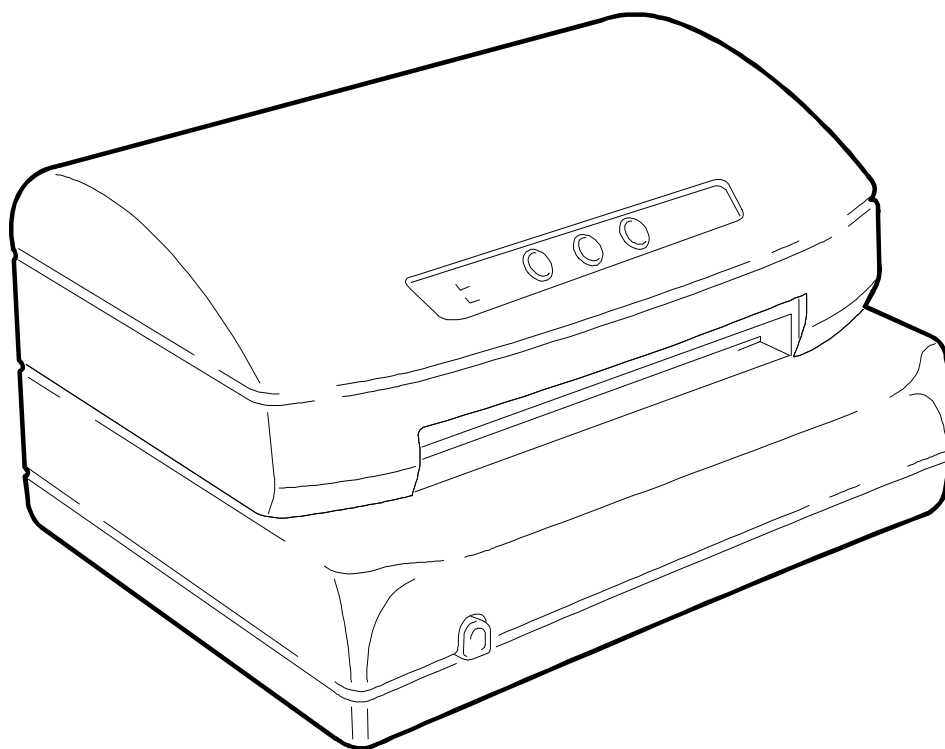




**MINUTERIA  
DETAILS**

**PR2/S10-S12-S12M-S13**

REF.	CODE	DESCRIZIONE	DESCRIPTION
1	750971 J	DADO M4 BLOCC. PONTE COM. PRESSORI	LINK FOR PRESSURE MECHANISM, M4 NUT
2	923032 A	VITE TRILOBATA M3x6	THREE LOBED SCREW M3x6
3	920617 S	VITE TESTA CILINDRICA M4x16	CHEESEHEAD SCREW M4X16
4	924710 T	VITE AUTOFORMANTE ø 2,2x6,5	THREAD-FOR. SCREW ø 2.2X6.5
5	924712 R	VITE AUTOFORMANTE ø 2,2x9,5	THREAD-FOR. SCREW ø 2.2X9.5
6	927005 L	VITE SCREWPLAST ø 2,9x6,5	SCREWPLAST SCREW ø 2.9X6.5
7	927006 M	VITE SCREWPLAST ø 2,9x9,5	SCREWPLAST SCREW ø 2.9X9.5
8	927013 B	VITE SCREWPLAST ø 2,9x13	SCREWPLAST SCREW ø 2.9X13
9	938220 E	DADO M3	M3 NUT
10	940098 A	RONDELLA ø 3,2x6	WASHER ø 3.2X6
11	940096 Y	RONDELLA ø 2,7x5	WASHER ø 2.7X5
12	940095 X	RONDELLA ø 2,2x5	WASHER ø 2.2X5
13	945230 F	STAFFA ø 2,3	ROD ø 2.3
14	945320 H	STAFFA ø 3,2	ROD ø 3.2
15	945500 F	STAFFA ø 5	ROD ø 5
16	926319 Z	STUD FILETTATO M3x4x1,5	STUD RIVET M3X4X1.5
17	664277 Q	VITE DI MASSA IN OTTONE M4	BRASS EARTH SCREW
18	920007 T	VITE TESTA CILINDRICA M2x8	CHEESEHEAD SCREW M2X8
19	921460 W	VITE TESTA CILINDRICA M3x8	CHEESEHEAD SCREW M3X8
20	920057 U	VITE TESTA CILINDRICA M46	CHEESEHEAD SCREW M46
21	921440 S	VITE TESTA CILINDRICA M2,5x4	CHEESEHEAD SCREW M2.5X4
22	473328 C	FASCETTA PER SMORZATORE	DAMPER CLAMP
23	723491 K	COLONNINA ESAGONALE M3X5	HEXAGONAL WHEEL BOX M3X5
24	966321 T	RONDELLA DENT. DIAM. 3,2X7	TOOTHED WASHER ø 3.2X7
25	945400 B	STAFFA DIAM. 4	ROD ø 4
26	920843 V	VITE TESTA ESAG. M3X6	HEX. HEADED SCREW M3X6
27	920864 S	VITE TESTA ESAG. CON INT. M4X6	HEX. HEADED SCREW M4X6
28	945700 P	STAFFA ø7	ROD ø 7

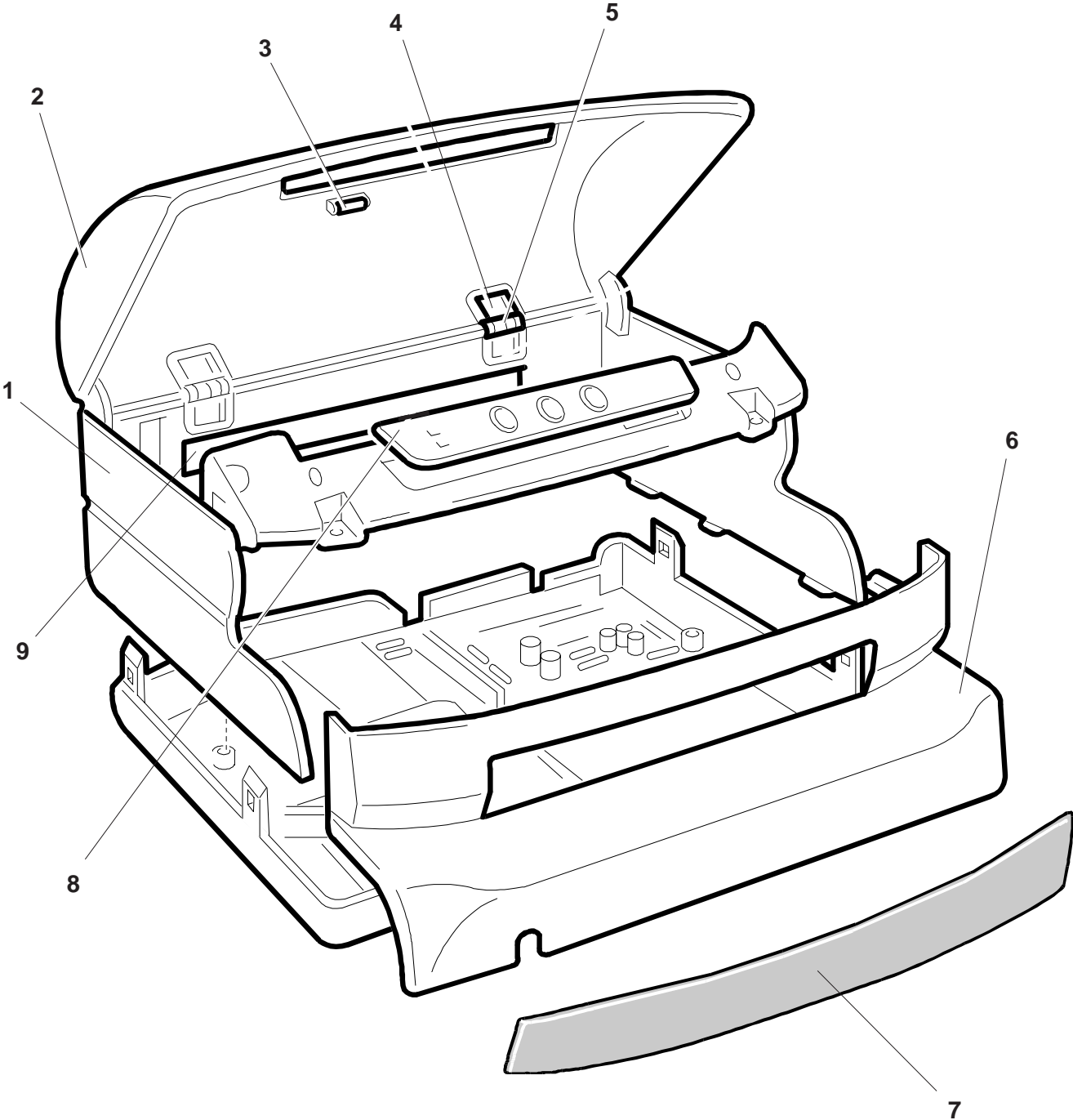


## **PR 2 SCANNER**

**CARROZZERIA  
CASING****PR2 SC**

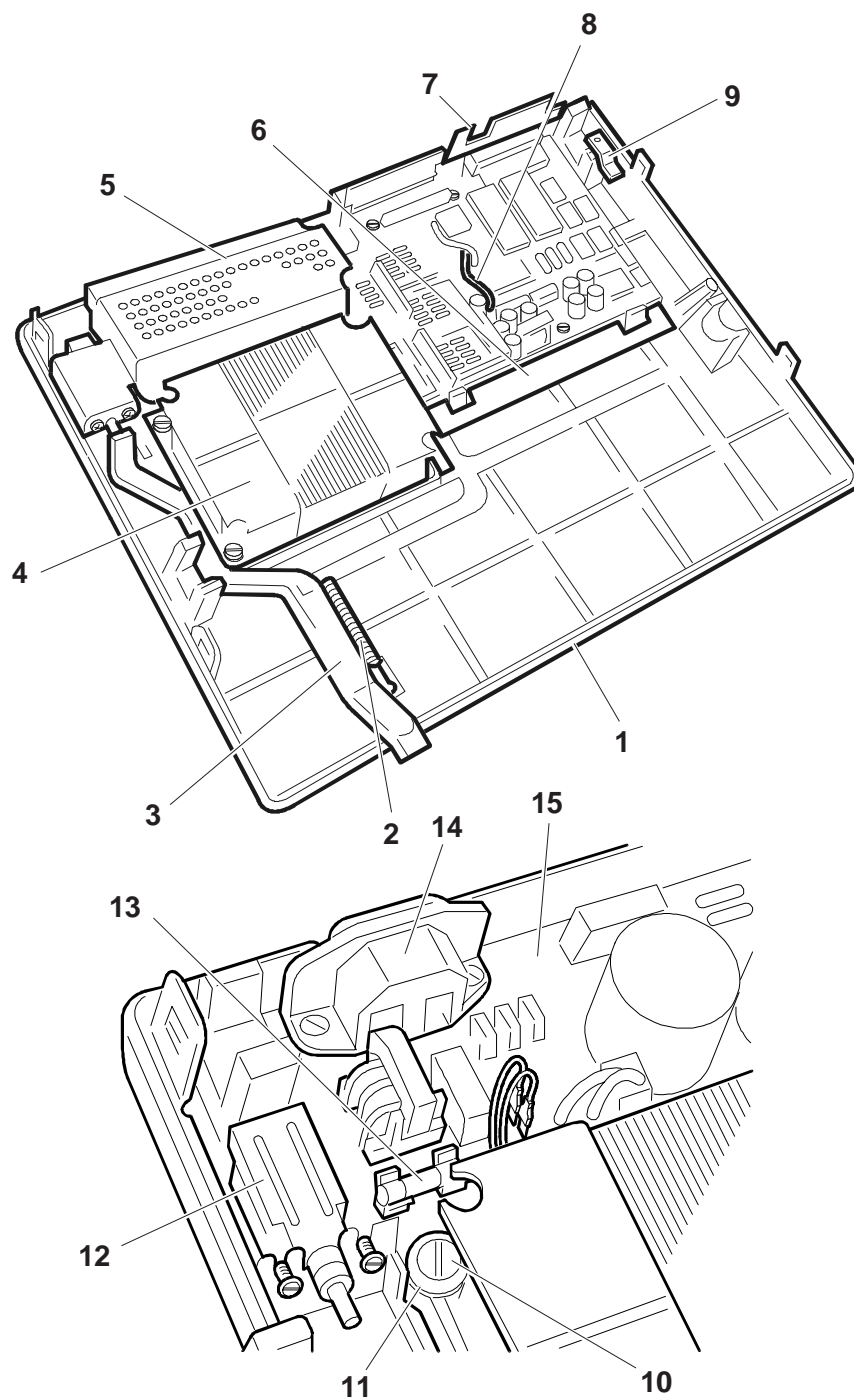
REF.	CODE	DESCRIZIONE	DESCRIPTION
1	474468A	GRUPPO SCOCCA	BODY ASSEMBLY
2	474469B	GRUPPO COPERTURA SUPERIORE	UPPER COVER ASSEMBLY
3	752610J	MAGNETE PER COPERTURA	COVER MAGNET
4	473540D	CERNIERA	HINGE
5	759410R	PERNO PER CERNIERA	HINGE FOR PIN
6	474471V	GRUPPO FRONTALE	FRONT SECTION ASSEMBLY
7	473506Y	FONOASSORBENTE ANTERIORE	FRONT DEADENING
8	475354G	CONSOLE	CONSOLE
9	474475Z	RIPARO POSTERIORE	REAR PROTECTION





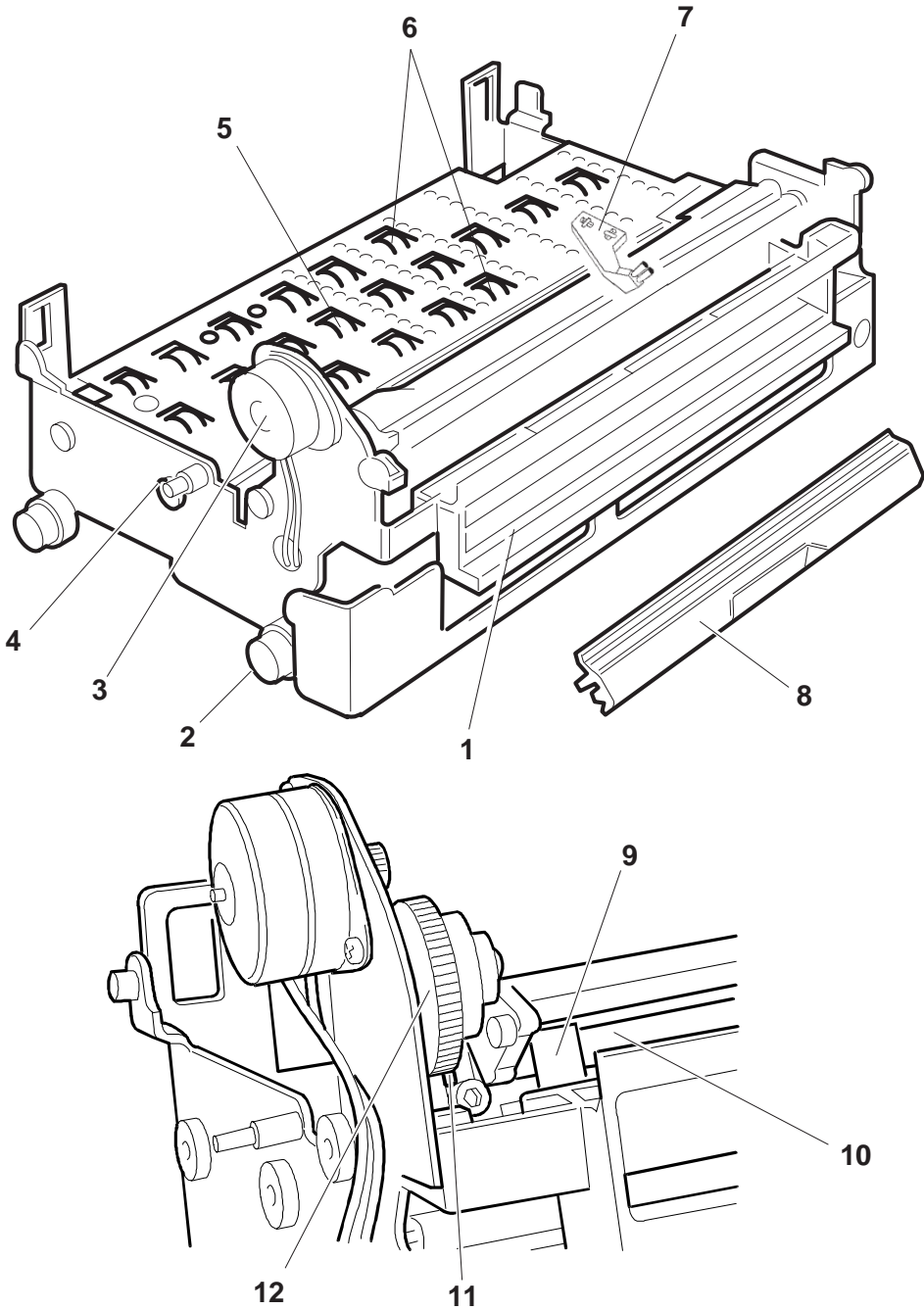
**GRUPPO FONDELLO E ALIMENTATORE  
BASE UNIT AND POWER SUPPLY****PR2 SC**

REF.	CODE	DESCRIZIONE	DESCRIPTION
1	475250L	GRUPPO FONDELLO	BASE UNIT
2	473034R	MOLLA CORSOIO INTERRUTTORE	SLIDING SWITCH SPRING
3	473033Q	CORSOIO INTERRUTTORE	SLIDING SWITCH
4	473108H	TRASFORMATORE 220-240 V.	220-240 V TRANSFORMER
	473109A	TRASFORMATORE 115 V.	115 V TRANSFORMER
5	473031N	CONTENITORE GRUPPO RETE	NETWORK UNIT COMPARTMENT
6	473030Z	SCHERMO PER PIASTRA	BOARD SCREEN
7	473032P	SCHERMO CONNETTORI	CONNECTOR SCREEN
8	474402Z	CAVO PIASTRINO ALIMENTAZIONE	CABLE FOR POWER SUPPLY BOARD
9	759413G	STAFFA FISSAGGIO MECCANICA	MECHANICAL FIXING ROD
10	723349K	STUD FISSAGGIO TRASFORMATORE	TRANSFORMER FASTENING STUD
11	723352E	GOMMINO SOSPENSIONE TRASFORMATORE	RUBBER SUPPORT FOR TRANSFORMER
12	5183323H	INTERRUTTORE RETE	NETWORK SWITCH
13	5358331H	FUSIBILE 2A-115V-5x20	FUSE 2A-115V-5x20
	5373182A	FUSIBILE 1,6A-220V-5x20	FUSE 1,6A-220V-5x20
14	471839T	GRUPPO PRESA RETE	NETWORK SOCKET UNIT
15	475327V	PIASTRINO ALIMENTATORE	POWER SUPPLY BOARD
16	475430Z	PIASTRA BASE SCANNER	SCANNER BOARD



**GRUPPO STRUTTURA INFERIORE  
LOWER SECTION****PR2 SC**

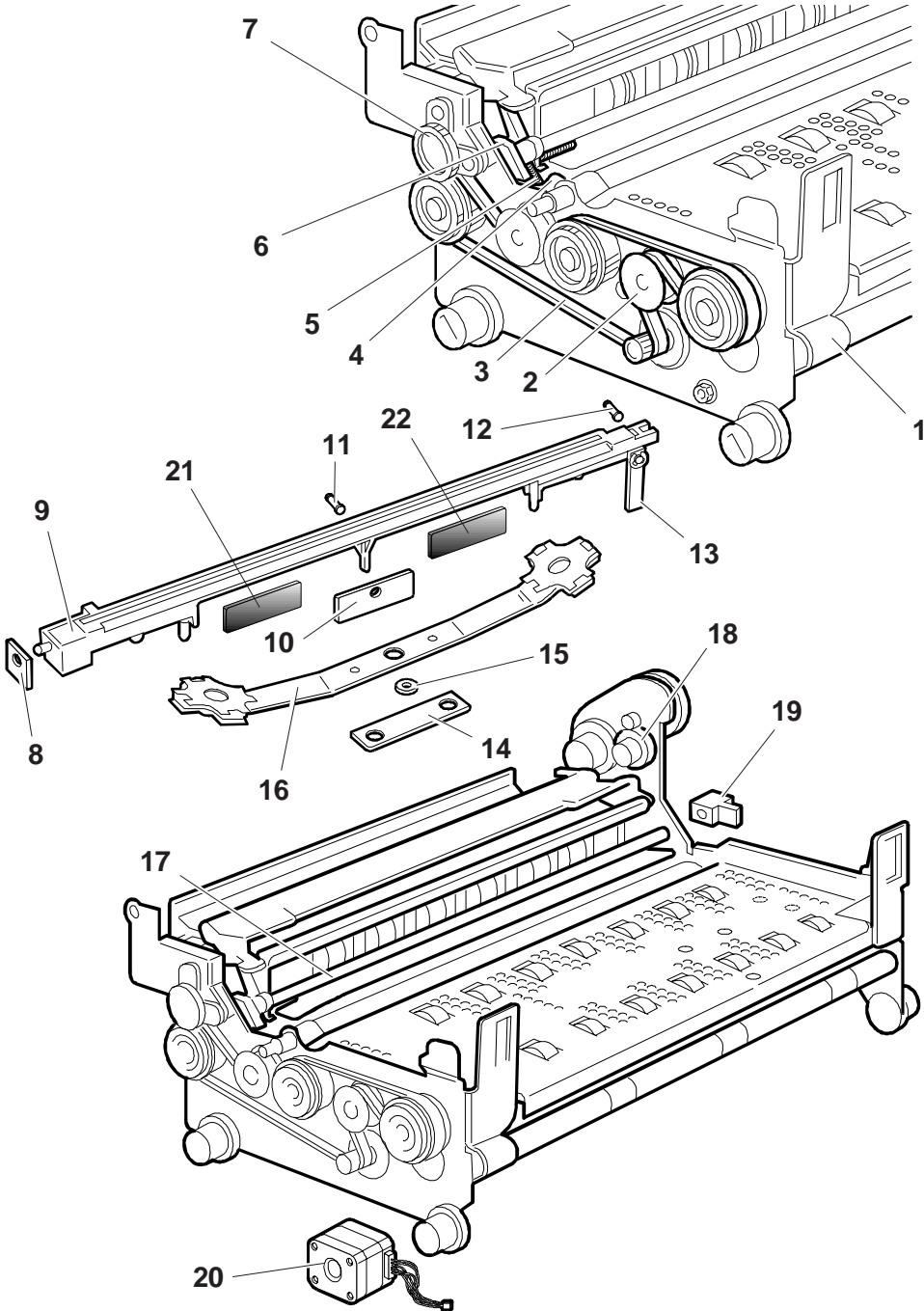
REF.	CODE	DESCRIZIONE	DESCRIPTION
1	473186P	CONVOGLIATORE CARTA	PAPER FEED
2	473013L	GOMMINO SMORZATORE STRUTTURA	DAMPING RUBBER FRAME
3	473069C	GRUPPO MOTORE SERVIZI	MOTOR SERVICE UNIT
4	473018Z	BOCCOLA SINISTRA	LEFT GUIDE BUSH
5	475108B	GR. RULLO CONTRASTO SCANNER	SCANNER CONTRAST ROLLER GROUP
6	475253B	GR. ALBERI DI TRASC. (Npz = 3)	FEED SHAFT GROUP (Pcs = 3)
7	473037L	PENNELLO	BRUSH
8	475249P	SPORTELLA DEFLETTORE SCANNER	SCANNER DEFLECTOR FLAP
9	473075S	PORTAMOLLA PRESSORI	PRESSURE SPRING HOLDER
10	473073Y	ALBERO SUPPORTO PRESSORI	PRESSURE SUPPORT ARM
11	473074Z	PONTE COMANDO PRESSORI	LINK FOR PRESSURE MECH.
12	473072X	CAMMA SERVIZI	SERVICE CAM



**GRUPPO STRUTTURA INFERIORE  
LOWER SECTION**

**PR2 SC**

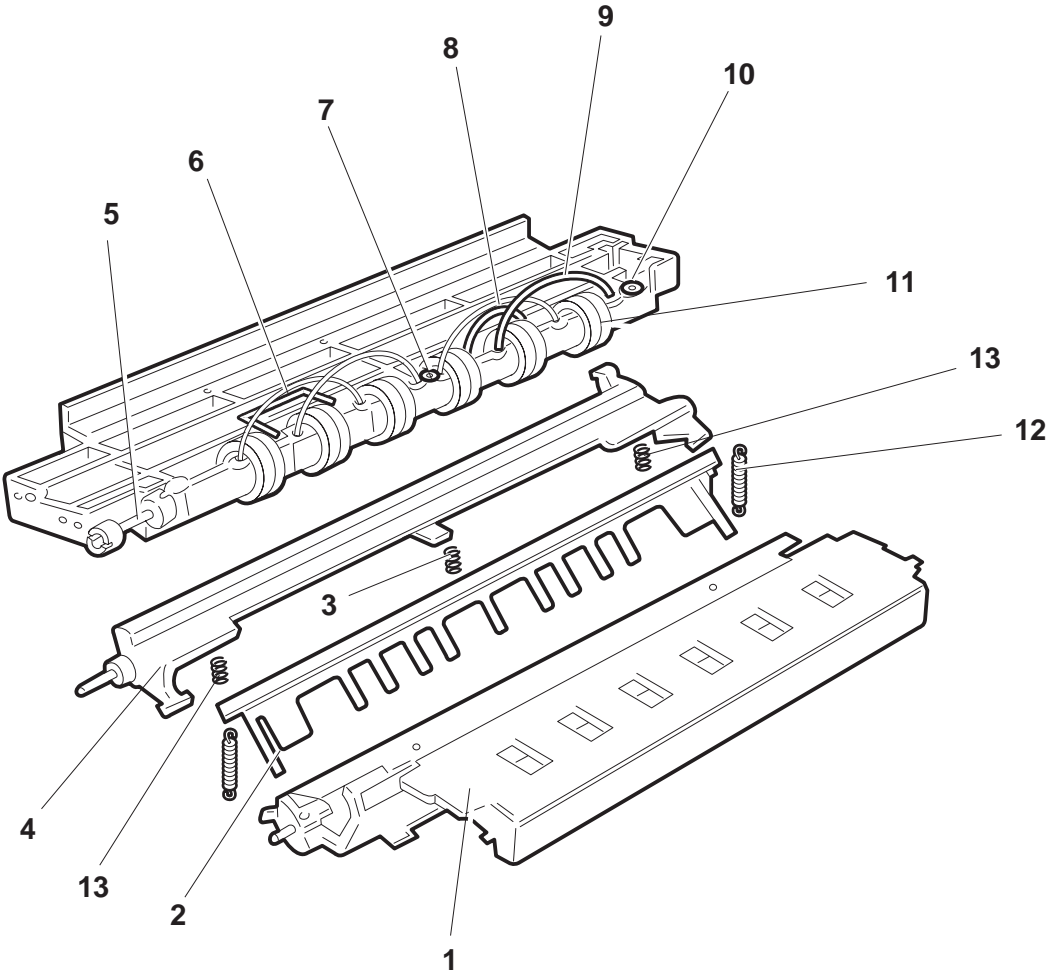
REF.	CODE	DESCRIZIONE	DESCRIPTION
1	473024 P	SCHERMO RULLINI	ROLLER SCREEN
2	473479 C	PULEGGIA TENDICINGHIA	BELT TENSION PULLEY
3	751171 D	CINGHIA TRASC. DOCUM. (Z=210)	DOCUMENT FEED BELT (Z=210)
4	473050 D	BILANCERE COMANDO BANDELLA	FLAP EQUALIZING DRIVE UNIT
5	473052 T	MOLLA GRUPPO BANDELLA	FLAP UNIT SPRING
6	473051 S	MANOVELLA COMANDO BANDELLA	FLAP CONTROL MECHANISM
7	473174 S	GR. COMANDO RULLINI PRESSORI	CONTROLS FOR ROLLER PRESSURE
8	473049 G	ZAVORRA SINISTRA	LEFT BALLAST
9	473040 B	GR. TRAVERSA DI STAMPA	PRINTER CROSSFLIGHT UNIT
10	473058 H	ZAVORRA CENTRALE (Npz = 2)	CENTRAL BALLAST (Pcs = 2)
11	473056 X	PERNO PER ZAVORRA CENTRALE	CENTRAL BALLAST PIN
12	473047 W	PERNO PER ZAVORRA DESTRA	RIGHT BALLAST PIN
13	473048 F	ZAVORRA DESTRA	RIGHT BALLAST
14	473063 W	PIASTRINO FISSAGGIO BALESTRA	BALLAST ANCHORAGE PLATE
15	473064 X	RONDELLA PER BARRA	BAR WASHER
16	473059 A	GR. BALESTRA AMMORTIZZ.	SPRING DAMPER UNIT
17	473054 V	GR. BANDELLA PREMICARTA	PAPER PRESSURE FLAP
18	473071 W	INGRANAGGIO DI RINVIO	INTERMEDIATE GEAR
19	473057 Y	LEVA APERTURA BANDELLA	FLAP OPENING LEVER
20	473020 X	GRUPPO MOTORE INTERLINEA	LINE SPACING MOTOR UNIT
21	473066 Z	SILENZIATORE TRAVERSA STAMPA POST.	FRONT PRINTING BAR DAMPENING (10 x 70)
22	473067 S	SILENZIATORE TRAVERSA STAMPA ANT.	REAR PRINTING BAR DAMPENING (6 x 70)



**GRUPPO STRUTTURA INFERIORE  
LOWER SECTION****PR2 SC**

REF.	CODE	DESCRIZIONE	DESCRIPTION
1	473085M	SUPPORTO CARTA FOTO ANTERIORE	FRONT PHOTO SUPPORT
2	473077U	PETTINE	COMB
3	473197J	MOLLA PRESSORI CENTRALE	CENTRAL PRESSURE SPRING
4	474954Z	SUPPORTO PETTINE	SUPPORT FOR COMB
5	473175T	GIUNTO	JOINT
6	473091K	MOLLA RULLINI ALLINEAMENTO	ALIGNMENT ROLLER SPRING
7	474953Y	BOCCOLA CENTRALE	CENTRAL GUIDE BUSH
8	473192M	FIBRA OTTICA L=80	OPTICAL FIBER L=80
9	473191L	FIBRA OTTICA L=100	OPTICAL FIBER L=100
10	473087P	BOCCOLA LATERALE	SIDE GUIDE BUSH
11	474943W	GRUPPO RULLINI ALLINEAMENTO	ALIGNMENT ROLLERS UNIT
12	473265D	MOLLA PETTINE (Npz = 2)	COMB SPRING (Pcs = 2)
13	473083K	MOLLA PRESSORE LATERALE (Npz = 2)	SIDE PRESSURE SPRING (Pcs = 2)

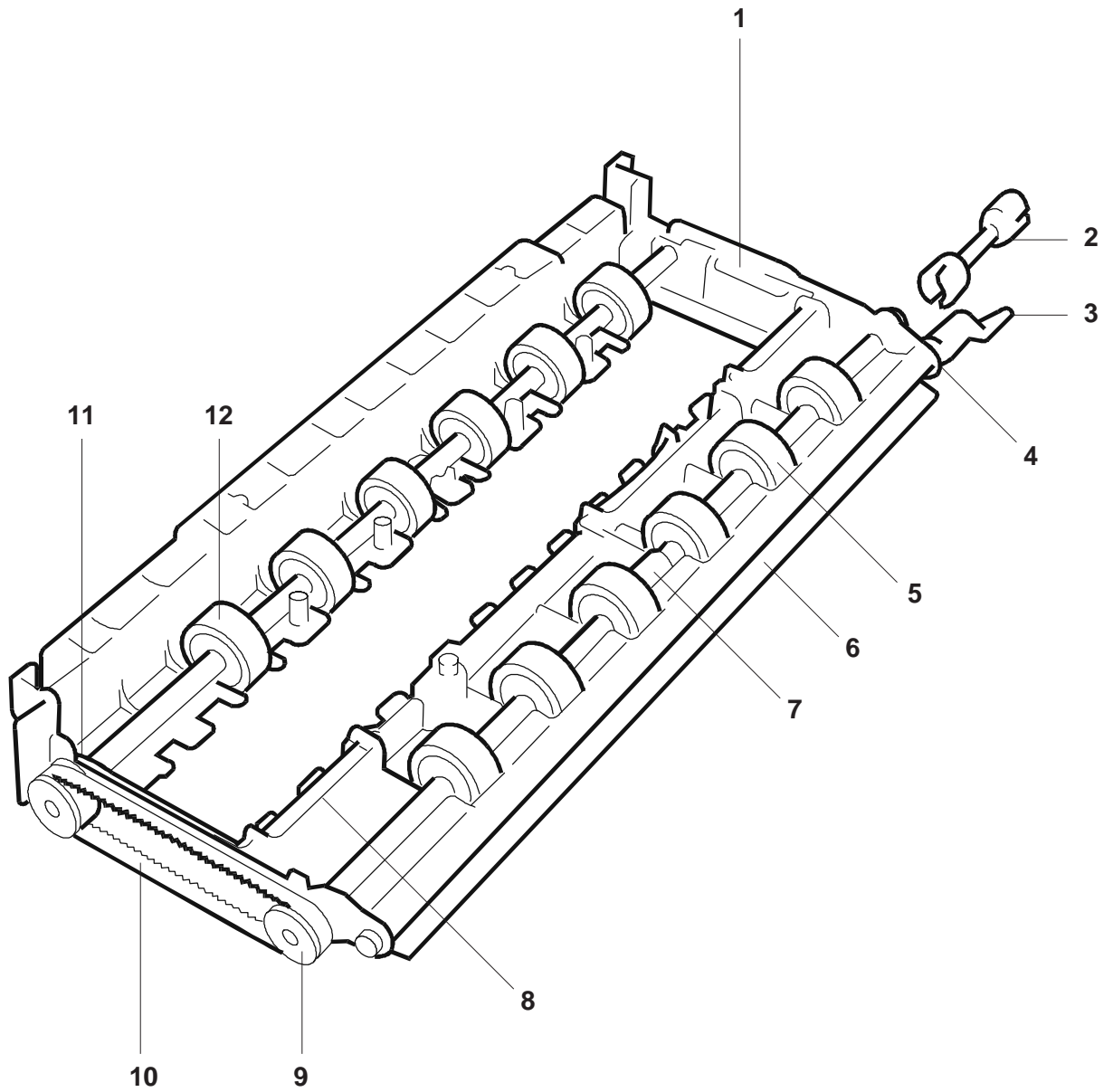




**GRUPPO PRESSORI POSTERIORI**  
**REAR PRESSURE UNIT**

**PR2 SC**

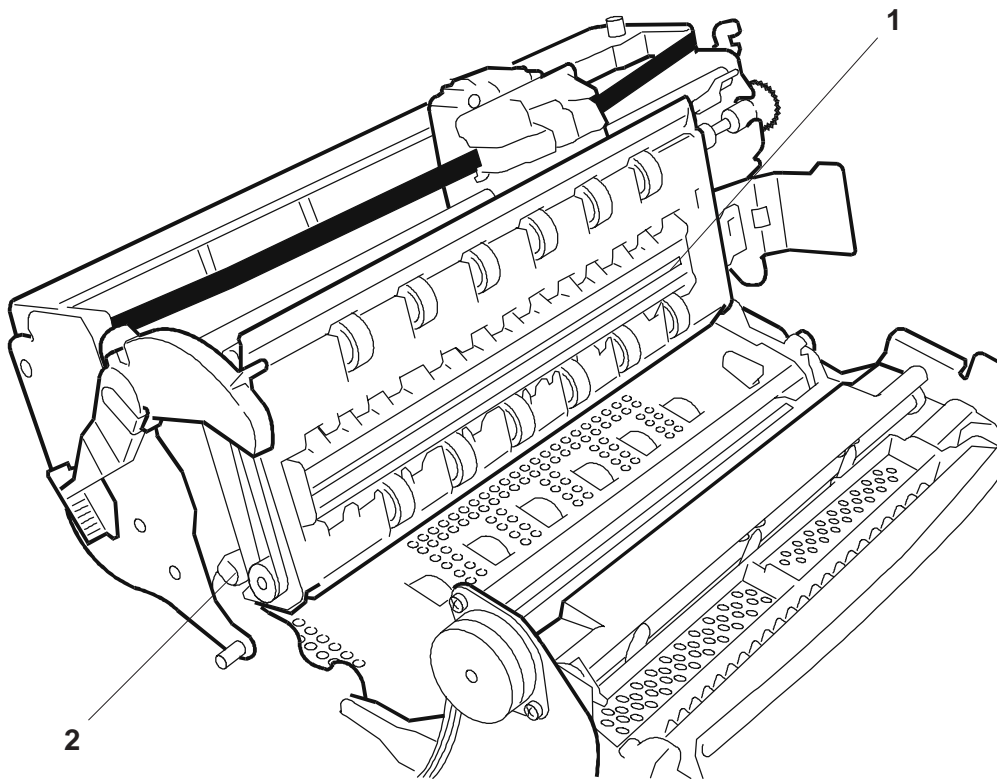
REF.	CODE	DESCRIZIONE	DESCRIPTION
1	475103W	SUPPORTO PRESSORI	PRESSURE UNITS SUPPORT
2	473175T	GIUNTO	JOINT
3	473393W	MANOVELLA	HANDLE
4	473394X	MOLLA A SPILLO	PIN SPRING
5	475116J	GRUPPO RULLINI ANTERIORI	FRONT ROLLERS UNIT
6	475105Y	MYLAR	MYLAR
7	475122Q	CONTRASTO ALBERO RULLINI ANTERIORI	FRONT ROLLERS SHAFT CONTRAST
8	473173Z	MOLLA TORSIONE	TORSION SPRING
9	473166S	PULEGGIA	PULLEY
10	473172Y	CINGHIA DENTATA Z=88	COGGED BELT Z=88
11	473171X	BOCCOLA SINISTRA	LEFT GUIDE BUSH
12	475114Q	GRUPPO RULLINI PRESSORI POSTERIORI	REAR PRESSURE ROLLERS UNIT



# GRUPPO SCANNER SCANNER UNIT

PR2 SC

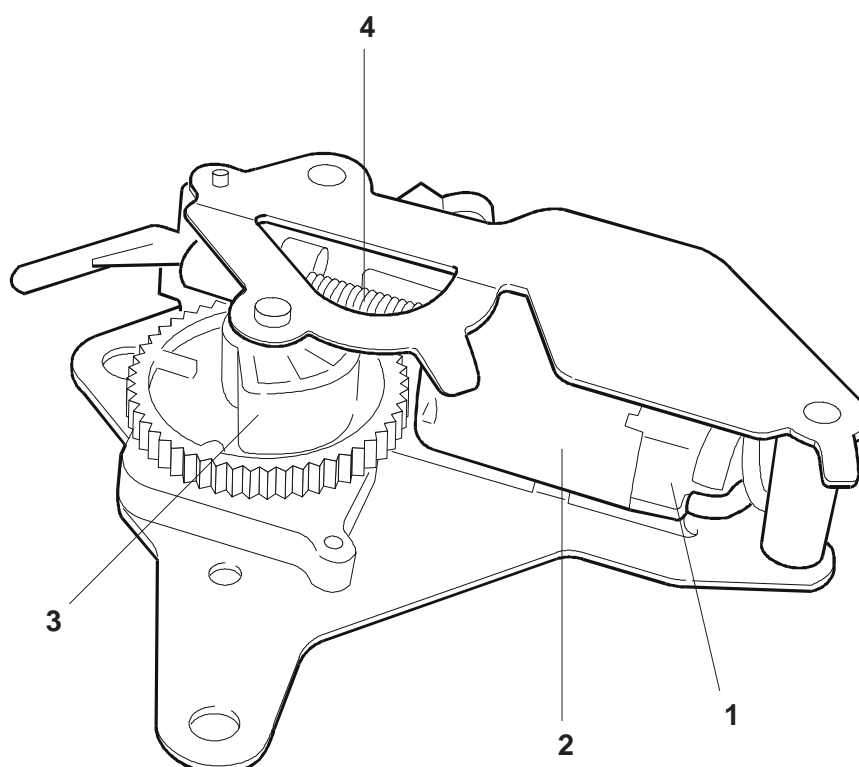
REF.	CODE	DESCRIZIONE	DESCRIPTION
1	475142U	GRUPPO SCANNER	SCANNER UNIT
2	475127M	GRUPPO MOVIMENTO SCANNER	SCANNER MOVEMENT UNIT



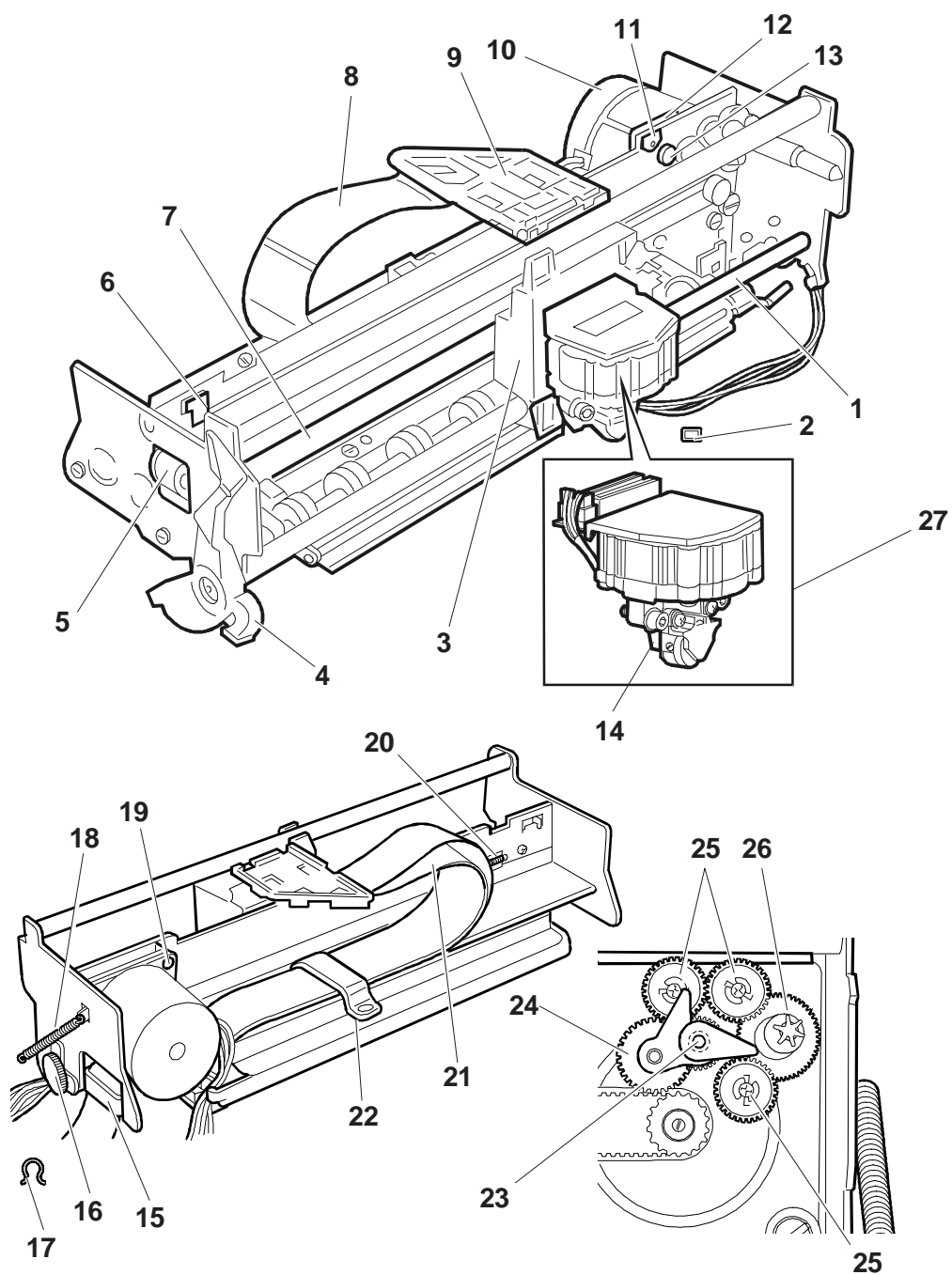
# GRUPPO MECCANICO SCANNER SCANNER MECHANICAL UNIT

PR2 SC

REF.	CODE	DESCRIZIONE	DESCRIPTION
1	475121 P	GRUPPO CIRCUITO STAMPATO SCANNER	SCANNER PRINTED CIRCUIT UNIT
2	475128 W	MOTORE SCANNER	SCANNER MOTOR
3	475145 X	CAMMA MOVIMENTO SCANNER	SCANNER MOVEMENT CAM
4	475251 H	PIGNONE SCANNER	SCANNER PINION



REF.	CODE	DESCRIZIONE	DESCRIPTION
1	473127K	ALBERO SUPPORTO CARRELLO	CARRIAGE SUPPORT SHAFT
2	473150E	FELTRO LUBRIFICAZIONE CARRELLO	CARRIAGE LUBRICATING PAD
3	473130S	CARRELLO SUPPORTO TESTINA	HEAD SUPPORT CARRIAGE
4	473129V	LEVA APERTURA STRUTTURA SUP.	OPENING LEVER FOR UPPER SEC.
5	751272J	PULEGGIA DI RINVIO	SNUB PULLEY
6	473149H	SUPPORTO TENDICINGHIA	BELT TENSION SUPPORT
7	473123P	CINGHIA TRASPORTO CARRELLO	CARRIAGE MOVEMENT BELT
8	473135K	SCHERMO FLAT TESTINA	PRINT HEAD FLAT CABLE SCREEN
9	473137M	SUPPORTO FLAT	SUPPORT FOR FLAT CABLE
10	473140C	MOTORE TRASPORTO CARRELLO	CARRIAGE TRANSPORT MOTOR
11	473156Y	STAFFA COLLEG. TERRA	EARTH ROD
12	473141Z	AMMORT. MOTORE TRASPORTO	TRANSPORT MOTOR DAMPER
13	471244E	STUD PER FISSAGGIO MOTORE	MOTOR ANCHORAGE STUD
14	475287W	GR. FOTOSENS. TASTATURA	SENSOR HEAD PHOTOELEC. UNIT
15	473139X	STAFFA DX GUIDA FLAT	RIGHT FLAT CABLE GUIDE ROD
16	473180V	GR. COMANDO RULLINI PRESS.	PRESSURE ROLLER DRIVE UNIT
17	473182K	BALESTRINA PER GR. BOCCOLA	BUSH UNIT LEAF SPRING
18	473151T	MOLLA PER LEVA DI BLOCC.	LOCKING LEVER SPRING
19	710769X	PIASTRINO FISS. MOTORE TRASP.	TRANSP. MOTOR ANCHOR. PLATE
20	473155X	MOLLA TENDICINGHIA	BELT TENSION SPRING
21	474400B	FLAT TESTINA	PRINT HEAD FLAT CABLE
22	473138W	STAFFA BLOCCAGGIO FLAT	FLAT CABLE ANCHORAGE ROD
23	473498Y	SCAMBIATORE	EXCHANGER
24	473131P	INGRANAGGIO COMANDO NASTRO	RIBBON DRIVE GEAR
25	753720R	RUOTA TRASCIN. NASTRO	RIBBON FEED WHEEL
26	473159B	INGRANAGGIO TRASCINAMENTO NASTRO	RIBBON FEED TOOTHED WHEEL
27	150376L	GR. TESTINA DI STAMPA	PRINT HEAD UNIT







# **INDICE GENERALE DEI CODICI**

# **GENERAL CODES INDEX**

**INDICE GENERALE DEI CODICI  
GENERAL CODES INDEX**

**PR 2**

CODICE CODE	PAGINA PAGE	CODICE CODE	PAGINA PAGE	CODICE CODE	PAGINA PAGE
150370S	32	473059A	50	473140C	16
150376L	16	473063W	10	473140C	58
150376L	58	473063W	50	473141Z	16
150418F	40	473064X	10	473141Z	58
471244E	16	473064X	50	473149H	16
471244E	58	473065Y	10	473149H	58
471501Z	22	473066Z	10	473150E	16
471501Z	36	473066Z	50	473150E	58
471514M	22	473067S	10	473151T	16
471514M	36	473067S	50	473151T	58
471530Z	22	473069C	8	473155X	16
471839T	6	473069C	48	473155X	58
471839T	46	473071W	10	473156Y	16
473013L	8	473071W	50	473156Y	58
473013L	48	473072X	8	473159B	16
473018Z	8	473072X	48	473159B	58
473018Z	48	473073Y	8	473160G	14
473020X	10	473073Y	48	473166S	14
473020X	50	473074Z	8	473166S	54
473024P	10	473074Z	48	473167T	14
473024P	50	473075S	8	473171X	14
473028T	8	473075S	48	473171X	54
473030Z	6	473077U	12	473172Y	14
473030Z	46	473077U	52	473172Y	54
473031N	6	473083K	12	473173Z	14
473031N	46	473083K	28	473173Z	54
473032P	6	473083K	52	473174S	10
473032P	46	473085M	12	473174S	50
473033Q	6	473085M	52	473175T	12
473033Q	46	473087P	12	473175T	14
473034R	6	473087P	52	473175T	52
473034R	46	473088Y	12	473175T	54
473037L	8	473091K	12	473180V	16
473037L	48	473091K	52	473180V	58
473040B	10	473108H	6	473182K	16
473040B	50	473108H	26	473182K	58
473047W	10	473108H	46	473186P	8
473047W	50	473109A	6	473186P	48
473048F	10	473109A	26	473191L	12
473048F	50	473109A	46	473191L	52
473049G	10	473123P	16	473192M	12
473049G	50	473123P	58	473192M	52
473050D	10	473127K	16	473197J	52
473050D	50	473127K	58	473240Q	12
473051S	10	473129V	16	473244G	14
473051S	50	473129V	58	473248L	14
473052T	10	473130S	16	473253H	8
473052T	50	473130S	58	473265D	12
473053U	10	473131P	16	473265D	52
473054V	10	473131P	58	473285S	22
473054V	50	473135K	16	473285S	36
473056X	10	473135K	58	473295U	30
473056X	50	473137M	16	473296V	30
473057Y	10	473137M	58	473298F	30
473057Y	50	473138W	16	473301A	22
473058H	10	473138W	58	473301A	36
473058H	50	473139X	16	473302B	22
473059A	10	473139X	58	473302B	36

**INDICE GENERALE DEI CODICI  
GENERAL CODES INDEX**

**PR 2**

CODICE CODE	PAGINA PAGE	CODICE CODE	PAGINA PAGE	CODICE CODE	PAGINA PAGE
473303C	22	473486L	36	475287W	16
473303C	36	473487M	36	475287W	58
473308R	22	473493K	26	475327V	6
473308R	36	473494L	26	475327V	46
473309J	22	473498Y	16	475354G	4
473309J	36	473498Y	58	475354G	44
473311T	22	473499Z	20	475430Z	46
473311T	36	473499Z	34	475764B	6
473312U	22	473501T	4	475765C	6
473312U	36	473503V	4	566998S	40
473313V	22	473506Y	4	664277Q	42
473313V	36	473506Y	44	710682H	22
473314W	20	473540D	4	710682H	36
473314W	34	473540D	44	710769X	16
473315X	20	474396S	40	710769X	58
473315X	34	474400B	16	723349K	6
473317Z	20	474400B	58	723349K	46
473317Z	34	474402Z	6	723352E	6
473320G	20	474402Z	46	723352E	46
473320G	34	474415M	40	723491K	42
473328C	42	474417P	40	750971J	42
473330A	22	474463V	4	751171D	10
473330A	36	474468A	4	751171D	50
473332Y	12	474468A	44	751272J	16
473344C	32	474469B	4	751272J	58
473346E	28	474469B	44	752610J	4
473348Q	30	474471V	4	752610J	44
473351B	32	474471V	44	753720R	16
473353D	30	474472W	6	753720R	58
473354E	30	474475Z	4	759410R	4
473355F	30	474475Z	44	759410R	44
473356G	30	474537P	40	759413G	6
473364G	30	474552W	40	759413G	46
473366A	30	474636S	40	920007T	42
473370J	30	474651H	40	920057U	42
473372G	30	474943W	52	920617S	42
473376C	28	474951W	20	920843V	42
473378N	30	474951W	34	920864S	42
473382T	30	474952X	22	921440S	42
473383U	30	474952X	36	921460W	42
473385W	30	474953Y	52	923032A	42
473386X	30	474954Z	12	924710T	42
473390F	30	474954Z	52	924712R	42
473393W	30	475103W	54	926319Z	42
473393W	54	475105Y	54	927005L	42
473394X	30	475108B	48	927006M	42
473394X	54	475114Q	54	927013B	42
473395Y	28	475116J	54	938220E	42
473396Z	28	475121P	57	940095X	42
473472V	4	475122Q	54	940096Y	42
473479C	10	475127M	56	940098A	42
473479C	50	475128W	57	945230F	42
473480S	36	475142U	56	945320H	42
473483R	36	475145X	57	945400B	42
473485K	22	475249P	48	945500F	42
473485K	36	475250L	46	945700P	42
473486L	22	475251H	57	966321T	42
		475253B	48	5183323H	6

**INDICE GENERALE DEI CODICI  
GENERAL CODES INDEX**

**PR 2**

CODICE CODE	PAGINA PAGE	CODICE CODE	PAGINA PAGE	CODICE CODE	PAGINA PAGE
5183323H	46				
5358331H	6				
5358331H	46				
5373182A	6				
5373182A	46				

